

The **TALKING**
MACHINE
WORLD

*For the
 makers &
 sellers of
 talking
 machines*

Published Each Month by Edward Lyman Bill, Inc., at 373 Fourth Ave., New York, January 15, 1923

Victrola

REG. U. S. PAT. OFF.

The word "Victrola" as well as the picture "His Master's Voice" is an exclusive trademark of the Victor Talking Machine Company. Being registered trademarks they cannot lawfully be applied to other than Victor products.



REG. U. S.
PAT. OFF.

"HIS MASTER'S VOICE"

Victor Talking Machine Company, Camden, N. J.

Now for the Greatest Sonora Year



Baby Grand



Elite

Prospects are excellent in 1923 for the greatest year Sonora has ever seen.

Sonora has always been close to the hearts of music lovers. Its leadership in tone quality; the happy faculty of creating designs that seize the fancy of the public, and a high standard of honest, thorough-going workmanship have placed it on an eminence that invites sales.

This broad foundation of Sonora popularity is constantly being strengthened by improvements and the development of new models, by fairness in price-making and a square deal at every turn to dealer and public alike.

Sell the Sonora for prosperity!

Sonora Phonograph Company, Inc.

GEO. E. BRIGHTSON, President

279 BROADWAY, NEW YORK

Canadian Distributors: Sonora Phonograph, Ltd., Toronto

THE INSTRUMENT OF QUALITY
Sonora
CLEAR AS A BELL 

"The Highest Class Talking Machine in the World."

The Talking Machine World

Vol. 19. No. 1

New York, January 15, 1923

Price Twenty-five Cents

BITNER'S NEW MUSIC STORE OPENED

Formal Opening of Handsome New Quarters Attended by Many Friends and Patrons

HANOVER, PA., January 5.—Bitner's Music Store, this city, recently held its formal opening to celebrate the removal of the business into the handsome new quarters at 118 Baltimore street. A host of friends and patrons were the guests of Mr. and Mrs. Fred C. Bitner at the opening and an entertaining and musical evening was enjoyed.

The new quarters are unusually artistic as to arrangement and appointments and there is plenty of room for the attractive display of the varied line of musical instruments handled by this firm, including a complete stock of Columbia Grafonolas and records, as well as pianos and other musical instruments.

SPECIAL VICTOR RECORD RELEASES

Five Popular Records From February Supplement to Be on Sale January 17

The Victor Talking Machine Co. has announced a special release of five records, part of the February supplement, which will be available to the retail trade in time to be placed on sale January 17. The records include a double-sided record containing the ballet music from Faust as played by the Victor Symphony Orchestra, another record of "When Hearts Are Young" and "Journey's End," and fox-trots played by Whiteman and his orchestra; "Lost" (a Wonderful Girl) and "Where the Bamboo Babies Grow," fox-trots played by the Great White Way Orchestra and the Virginians respectively; "My Buddy" and "When Winter Comes," fox-trots played by the International Novelty Orchestra and the Great White Way Orchestra, and finally, "Thru the Night" and "Red Moon," two popular waltzes played by the Serenaders.

BRING STOCK TO PROSPECTS' HOMES

Schwartz Bros., Columbia Dealers, Norwich, Conn., Use Unique Auto Truck to Interest Prospective Customers in Their Line

NORWICH, CONN., January 5.—Schwartz Bros., Inc., Columbia dealers, this city, are waging an intensive sales campaign in the interest of the Columbia line of machines and records, using a novel method of bringing this line to the attention of prospective customers. A miniature house constructed on an automobile chassis, according to plans drawn up by L. H. Webber, manager of the Grafonola department, is used. The machine holds six machines and a large quantity of records, and by this means a representative variety of instruments and records are carried directly to the homes of the prospect. The plan has been found very effective in stimulating interest in the line.

CLEVELAND CONCERN CHARTERED

CLEVELAND, O., January 5.—The Buckeye Phonograph & Sales Co., this city, was recently granted a charter of incorporation under the laws of this State, with a capital of \$10,000. Incorporators are Don L. Taylor, Arnold Sheaffer, B. Brown, Emery C. Smith and C. T. Kirkbride.

A writer to the New York Times has called attention to the fact that the new traffic tower at Fifth avenue and Forty-second street is shaped like a bronze phonograph. Why not a real musical instrument to entertain the watchful traffic "cop"?

LEBEDEFF WITH THE VOCALION CO.

Prominent Singer of Russian and Jewish Songs to Record Exclusively for Vocalion

Aaron Lebedeff, famous singer of Russian and Jewish songs, recently signed an exclusive contract to record for the Vocalion Red record and his first record will appear in the Vocalion bulletin at an early date. Mr. Lebedeff came to the United States from Moscow about two



Aaron Lebedeff

years ago, after enduring great hardships in Russia, and met with instant success in this country, being hailed as the Al Jolson of the Jewish theatre.

BELIEF IN PRODUCT ESSENTIAL

The Salesman Not Convinced That the Line He Represents Is the Best Will Achieve Greater Success if He Changes His Post

To be successful a salesman must have a number of qualifications. Time and time again it has been stressed that a salesman should have a complete knowledge of his line as well as that of his competitors so that he can intelligently answer questions and set forth the merits of the product which he is trying to sell. But this knowledge is not enough. It must be backed up with enthusiasm and sincerity. Without a firm belief in his product a man stands small chance of selling the prospect who is doubtful of his line. He lacks the force which will bring about a change in front on the part of the prospect and change the doubt to belief. Sincerity and enthusiasm accomplish this result. If a salesman does not thoroughly believe in the line he represents it would be much better for him to make connections with the concern handling a product which he is convinced is superior in merit. In this manner only will he do his best work and achieve the greatest measure of success.

HEADQUARTERS FOR IOWA STATE

CEDAR RAPIDS, IA., December 21.—G. W. Guess, Iowa representative of the Interstate Phonograph Co., of Chicago, which in turn is factory representative of the Pathé Phonograph & Radio Corp., New York, has established headquarters in this city for the State. Mr. Guess reports much activity throughout his territory and is optimistic over the business outlook.

Overlooking complaints of customers or treating them discourteously is a sure way of making enemies and losing trade.

TO EXPAND THE PATENT OFFICE

Joint Committee of Senators and Representatives Suggested for Purpose of Studying Patent Office Situation and Recommending Means for Overcoming Present Congestion

WASHINGTON, D. C., January 5.—Expansion of the Patent Office to a point where it can take care of its work comfortably and efficiently may come about as a result of an investigation sought by Representative Perkins, of New Jersey, who has introduced a resolution in Congress providing for the creation of a joint commission of Senators and Representatives to inquire into conditions at the Patent Office. The proposed commission would be required to make its report within a month.

There has been constant complaint that the facilities of the Patent Office are inadequate to handle the vast amount of business which comes to it and that the salaries paid are entirely too low for the work and make it impossible for the Government to retain the best-trained employees. The salary situation was, to some extent, taken care of by increases made by Congress some time ago, but even yet the average salary is far below that which commercial houses are willing to pay for the same services, and outside interests are always anxious to secure men trained in the Patent Office.

At the present time the office is several months behind on its work, to the hardship of inventors and business men who are anxious to market new commodities. The proposed inquiry would cover all phases of the situation and, it is expected, would develop all facts upon which Congress could act to remedy adverse conditions in the Patent Office.

WILL MAKE BRUNSWICK RECORDS

Capitol Grand Orchestra, Largest Theatre Orchestra in the World, Enters Recording Field—First Record in January List

A. J. Kendrick, general sales manager of the Brunswick-Balke-Collender Co., announces that the Capitol Grand Orchestra, playing at the Capitol Grand Theatre, New York City, will now record exclusively for Brunswick. The Capitol Grand Orchestra, Erno Rapee, conductor, consists of seventy-five members and is the largest theatre orchestra in the world. The music library of this organization contains more than 15,000 cataloged selections, embracing the works of over 1,500 different composers, and including symphonic scores, operas, chamber music, popular overtures, light opera, musical comedies, folk dances, choral music, classic lieder, popular ballads and folk songs. The first Brunswick recording of the Capitol Grand Orchestra is the "Orpheus in Hades Overture, Part 1 and 2," released in January.

AN ENTHUSIASTIC RECORD COLLECTOR

An enthusiastic collector of records is J. Leo Langmesser, a machinist on one of the Great Lake steamers, who has a record collection comprising more than sixteen hundred Victor records, most of them Red Seals. Mr. Langmesser, who is a steady customer of the Buffalo Music Co., Buffalo, N. Y., started his record collection many years ago and he is constantly adding to it.

D'LYTE CO., INC., CHARTERED

D'Lyte Co., Inc., of Wilmington, Del., has been granted a charter of incorporation under the laws of that State, with a capital of \$300,000. The concern will engage in the manufacture of talking machines.

Talking Machine as an Educational Medium Offers Fine Field for Business Development

A field which is slowly being developed by the more aggressive talking machine dealers in various parts of the country is that of exploiting the talking machine as an educational medium in public schools. There are some dealers who neglect this avenue of sales because they think it is not large enough to warrant their serious consideration along lines dealing with an educational campaign, advertising and other publicity directed at the heads of the schools and the boards of education.

However, the fact remains that this is one of the most fertile fields yet remaining for talking machine dealers of which to take advantage. Dealers should bear in mind that in every community there are usually several schools and it is well worth the effort to make not only the two, three or more sales to the schools and the profit incidental thereto, but the fact that these sales have been consummated and the students thereby given an opportunity for musical development will no doubt have considerable influence on future sales.

Selling a talking machine and a library of records to the head of a school, or selling the idea of supplying all schools in a community with these instruments, is an entirely different problem from successfully approaching and consummating a sale with a householder. The methods which make for success in selling to educational institutions must be worked out along businesslike lines. Where the dealer or salesman makes his appeal to the ordinary prospect through the emotions the results from this mode of procedure, when applied to a principal of a school, or a board of education, would in all likelihood be nil.

The salesman must first arm himself with facts concerned directly with the actual value to be derived by the pupils from the talking machine. He must be in a position to prove without question of doubt that the talking machine is the best medium through which the pupils can derive a thorough education along musical lines. In addition to this he must convince these gentlemen, as he would any ordinary

Many schools throughout the country are now equipped with talking machines and adequate libraries of records, and the list is growing steadily larger. It is not only in this country that the talking machine is playing an important part in the educational system, but also in Europe, notably England. As an example of the extent to which this method of teaching music has been carried in that country the case comes to mind of a series of nine records recently completed by Dr. Walford Davies, Professor of Music at the University of Wales and a composer of some note. The records contain a series of short lectures on melody which are freely illustrated by violin and piano playing and have already proved their value. The time is no doubt coming when more ambitious plans will be formulated in this country for the use of the talking machine in connection with educational work.

From a purely mercenary standpoint the proposition is well worth the attention and consideration of thoughtful merchants with an eye to the future success of their business enterprises. In a medium-sized city close to metropolitan New York there is a talking machine dealer who has supplied most of the schools in his city with machines and records and he is now concentrating his efforts on educational institutions in surrounding cities and towns. As an indication of the sales opportunities it may be stated that this dealer has already sold more than fifteen machines and a great many records during the course of the past year. The opportunity is there and the rewards will go to the dealers who are farsighted enough to take advantage of it.

New Avenue of Sales Awaiting Action on the Part of Dealers With an Eye to More Business and Profits

prospect, that the machine he handles is undoubtedly the one best suited for the purpose.

If a salesman or dealer finally succeeds in making an appointment with the head of an educational institution, the wisest procedure would be to make a detailed list of the records in his library which could be used for educational purposes. With these facts in his possession he is prepared to discuss the matter from a business standpoint and at the same time along lines appealing to the educator.

Let PREPAREDNESS be your MOTTO for 1923

THE TALKING MACHINE'S HELPMATE



The big volume of sales at the end of last year in Talking Machines means big business in 1923 in both records and albums.

Prepare to meet this demand now with Nyacco albums. It will pay you to anticipate your album requirements for some time to come and place your orders at this time. Raw material prices are advancing. Purchase now and get the lower prices.

The Best Interchangeable Leaf Record Album on the Market



Write for display card—mailed without cost. It will help you sell more Nyacco Albums

New York Album & Card Co., Inc.

NEW YORK
23-25 Lispenard St.

Western Coast Factory Representative,
E. R. DARVILL—Munson Raynor Corp.,
315 S. Broadway, Los Angeles, Cal.

CHICAGO
415-417 S. Jefferson St.

Victor supremacy is the supremacy of performance



Victrola VI, \$35
Mahogany or oak



Victrola IX
\$75
Mahogany or oak



Victrola No. 80
\$100
Mahogany, oak or walnut

Dealers in Victor products handle a known quantity—a line of products that has demonstrated its worth by a quarter-century of actual accomplishments.



Victrola No. 130
\$350
Victrola No. 130, electric, \$390
Mahogany or oak



Victrola No. 210
\$100
Mahogany or walnut



Victrola No. 240
\$115
Mahogany, oak or walnut



Victrola No. 280
\$200
Mahogany or walnut



Victrola

REG. U. S. PAT. OFF.

Important: Look for these trade-marks. Under the lid. On the label.
Victor Talking Machine Company
Camden, New Jersey

Close of the Old Year Leaves Clear Field for New Year of Progress and Prosperity

The holidays are now merely a memory of the past and no doubt there will be, as has been the case in former years among a certain class of dealers, a tendency to relax and take it easy with a complacent feeling that the advent of the holidays resulted in a very substantial volume of business and profits. Few dealers will take the trouble to analyze the reasons for the excellent demand for machines and records during the holiday period. Many will content themselves with the thought that because of the fact that this season is a time for gift-giving business was good. It is now in order to remark with the greatest possible emphasis that while the spirit of the season has had a great deal to do with sales volume there is another factor which has been of equal, if not greater, importance in developing the demand, namely, sales efforts of all descriptions.

Prior to the holidays dealers everywhere devoted their most energetic efforts toward developing and intensifying the demand for machines and records. Probably chief among the mediums used to bring about this most desirable result was advertising—not mediocre publicity, but advertising that brought home to readers the fact that a talking machine or a selected list of records would make an ideal gift for a loved one, a gift that would bring pleasure and entertainment, and one that was most appropriate. Direct-by-mail literature of an equally high order and artistic window displays of a type which exerted distinct appeals and put forth the talking machine and records in a most favorable and forcible manner were also contributory to the success enjoyed.

As stated in the first paragraph, if the practice of former years is followed many merchants will curtail their efforts now that the season is over, and, as in former years, the results will be no more than can be expected—business will suffer a corresponding drop.

No doubt many machines have been sold and here lies the greatest opportunity for the dealers to start the new year with a continuation of the fine business which was in effect before

the holidays. But there can be little hope or expectation of a decent sales volume where effort has been reduced to an absolute minimum. If anything, even greater pressure must be brought to bear in the various factors which result in sales, i.e., sales efforts, advertising and publicity of all kinds, and window displays. Only by these means will merchants reap the benefit of the possibilities which are now at hand and only in this way will 1923 be the banner year that has been predicted by the

Continuation of Intensive Sales Efforts Necessary for Steady Upbuilding of Sales Throughout the Year

keenest business men in the trade throughout the country. Many machines have been sold and there is now an unworked, absolutely new record field to be developed as a result. The opportunity is there for the most aggressive to take advantage of and it can be truly said that the next twelve months will only be banner ones, in a business sense, to those who do not pass up any chances of making sales.

Smug satisfaction with what is past will not do the trick. The profits derived from pre-holiday sales will dwindle fast enough unless business is kept up to a substantial level which will preclude the possibility of backsliding. How many are there who have already made fine resolutions to make 1923 the best year ever? How many are there who have made plans to increase their efficiency in every

branch of their business? Last, but not least, how many are there who have already broken and forgotten their good resolutions? It is safe to say that many, jubilant with sales which were largely brought about through intensive merchandising policies, have already dropped back to the old rut of lethargic self-satisfaction. Get out of the rut! Dig out and go after business with that determination which admits no defeat and overcomes all obstacles which block the path! Do your share and make the New Year the best ever!

There is another field for development which the dealer can turn into profits and good-will. Prior to the holidays it is safe to say that many people in every community were attracted by the advertising and window displays of talking machine dealers and while they have not as yet purchased a machine the desire has been aroused to such a high pitch that it only requires the least persuasion on the part of a diplomatic and live salesman or dealer to call the turn and secure the name to the dotted line. If these people are neglected now, however, the desire is bound to become less and less as the days and weeks drag on, until the power and influence exerted by the pre-holiday advertising and solicitation has faded away and, consequently, the prospects will have to be sold all over again—an expensive loss of time and inconvenience which can easily be dispensed with by prompt action now. It is wise to always bear in mind that the basic principle of good business is quick stock turnover at a fair profit and certainly the movement of stock will not be facilitated by neglecting the excellent opportunities which are now at the command of practically every dealer throughout the country. There can be no doubt that the bulk of the business will be done by the workers.

Dealers need only look back to those months in the past when the business world was filled with black storm clouds to find sufficient reasons on which to base successful policies. Business has just crawled from the dumps to a fairly respectable position and what the future holds in store for the trade will be just what it deserves—no more and no less. And what it deserves will be measured entirely by the amount of energy and intelligence displayed. There is an old adage by which many dealers seem to be guided, to their ultimate sorrow. It reads as follows: "Everything comes to him who waits." In the talking machine business there could not possibly be a more dangerous doctrine on which to base policies of operation. The fellow who plays a watchful, waiting game in the year 1923 will find the sheriff hammering on the door some bright and sunny morning and another merchant will have his future behind him. To-day, as never before, the go-getters are the birds who are reaping the profits. The others are merely holding the sack. Competition is more keen than has ever been the case, but the wide-awake dealer need have no fears on this score if he plays the game on the square and, like the athlete, goes the limit and puts every ounce of his energy and intelligence to work.

What the future holds no man can foresee, but he can, by his own efforts and brainwork, insure himself against a dismal ending, and the best possible service that can be performed is to point out the possibilities and then—why, that rests with the dealer. The problem is similar to that of the ducky who declared to his friend that although he had been drafted he would not fight. His friend answered: Well, Big Boy Uncle Sam ain't sayin' as how you got to fight. He's jest leadin' yo' to where de fight is and den he lets you use yo' own judgement."



BRUNS
MADERITE

MADERITE

Phono Moving Covers

Cover, Straps Attached



An ounce of caution is worth endless complaint and repolishing

Every progressive dealer needs a supply of dependable moving covers. Mr. Average Man dislikes to unpack anything he buys. By using padded delivery covers you protect and deliver a perfect instrument with no necessity for dirt, inconvenience or trouble to your customer.

It is much more simple to slip a cover over an instrument at the store and off at point of delivery and the impression left with your customer is pleasant. MADERITE covers are strong, well padded and satisfactory from every standpoint.

Consult your accessory jobber, phono distributor or write us for literature and prices.

A. BRUNS & SONS
Manufacturers of Canvas Goods

50 Ralph Ave., Brooklyn, N. Y.

A. BRUNS & SONS
50 RALPH AVE.
BROOKLYN
N. Y.

Victor supremacy is the supremacy of performance



Victrola IV, \$25
Oak



Victrola VIII, \$50
Oak

Of performance past and present. Just as the Victor has occupied its position of leadership for a quarter-century, so it continues to lead the way in the talking-machine industry.



Victrola No. 100
\$150
Mahogany, oak or walnut



Victrola No. 120
\$275
Victrola No. 120, electric, \$315
Mahogany or oak



Victrola No. 230
\$375
Victrola No. 230, electric \$415
Mahogany



Victrola No. 260
\$160
Mahogany or walnut



Victrola No. 300
\$250
Victrola No. 300, electric, \$290
Mahogany, oak or walnut



"HIS MASTER'S VOICE"
REG. U. S. PAT. OFF.

Victrola

REG. U. S. PAT. OFF.

Important: Look for these trade-marks. Under the lid. On the label.
Victor Talking Machine Company
Camden, New Jersey

The TALKING MACHINE WORLD

For the makers & sellers of talking machines

(Registered in the U. S. Patent Office)

PUBLISHED BY EDWARD LYMAN BILL, Inc.

President and Treasurer, C. L. Bill, 373 Fourth Ave., New York; Vice-President, J. B. Spillane, 373 Fourth Ave., New York; Second Vice-President, Raymond Bill, 373 Fourth Ave., New York; Secretary, E. L. Bill; Assistant Treasurer, Wm. A. Low.

J. B. SPILLANE, Editor

RAY BILL, B. B. WILSON, BRAID WHITE, Associate Editors
LEE ROBINSON, Advertising Manager
L. E. BOWERS, Circulation Manager

Trade Representatives: A. F. CARTER, C. CHACE, EDWARD LYMAN BILL, V. D. WALSH, E. B. MUNCH, C. R. TIGHE, A. J. NICKLIN

Western Division: Republic Building, 209 So. State Street, Chicago, Ill. Telephone, Wabash 5242

Boston: JOHN H. WILSON, 324 Washington Street

London, Eng., Office: 2 Gresham Building, Basinghall St. W. LIONEL STURDY, Mgr.

The Talking Machine World has regular correspondents located in all of the principal cities throughout America.

Published the 15th of every month at 373 Fourth Ave., New York.

SUBSCRIPTION (including postage): United States, Mexico, \$2.00 per year; Canada, \$3.00; all other countries, \$4.00. Single copies, 25 cents.

ADVERTISEMENTS: \$5.50 per inch, single column, per insertion. On quarterly or yearly contracts a special discount is allowed. Advertising pages, \$150.00.

REMITTANCES should be made payable to Edward Lyman Bill, Inc., by check or Post Office Money Order.

NOTICE TO ADVERTISERS—Advertising copy should reach this office before the first of each month. By following this rule clients will greatly facilitate work at the publication headquarters.

Long Distance Telephones—Numbers 5982-5983 Madison Sq.
Cable Address: "Elbill," New York

NEW YORK, JANUARY 15, 1923

ENTERING THE NEW YEAR WITH CONFIDENCE

THERE is no question but that the majority of talking machine men have entered the New Year with a distinct feeling of satisfaction over business conditions during the past few months and with full confidence that the New Year in the main will witness a continuance of those conditions. The last few months of 1922 saw the actual turning of the business tide which had been predicted for months, and even those who were most confident that there would be an improvement were in many cases caught short of stock before the first of January rolled around.

Particularly satisfying is the fact that the trade emerged from 1922 with a clean slate. Retail stocks of machines particularly were in most cases brought down to a very low level during the holiday buying period. Manufacturers' stocks, almost without exception, were in the same condition. The market has been pretty well cleared of the flood of machines that were unloaded at all kinds of prices in an effort to effect liquidation, which means that standard goods can again be handled at right prices and in a normal manner without being faced with such harmful competition.

To make definite predictions regarding the entire year of 1923 would be a rather difficult proposition, for the reason that any prediction that goes well into the future is very likely to be upset by changes and conditions that cannot be foreseen. Nineteen twenty-three opens a new chapter in the history of the talking machine industry, and it is timely to emphasize the need for continued interest and action by all branches of the trade toward constructive policies that will mark new achievements. We have emerged successfully from the anarchistic industrial conditions brought about through post-war experiences. Prices are more stabilized. The buying demand is becoming more strongly developed, and it is up to manufacturers and dealers not only to satisfy this demand for machines and records, but to increase it by intensified and intelligent constructive policies.

OVERCOMING THE INCLINATION TO RELAX

FOLLOWING the holiday campaign there is always a tendency to rest on one's oars and not press the campaign for more business by getting after it vigorously and unrelentingly. This is a huge

mistake. The talking machine business is not seasonal, though some dealers, it is true, act as if it were.

Leading merchants, whose business is always progressing—those who have studied the psychology of the buying public—are on record as saying that it is dangerous to allow any time for reaction following a great sales drive such as occurs during the Christmas and New Year holiday periods. The retailer must keep in touch with the public, follow up recent buyers, particularly in the record line, and try to augment sales. On the basis of service is this particularly desirable, for every merchant should sell "his house" and his ability to serve those who extend patronage to him. Nineteen twenty-three should be distinguished by a higher conception of merchandising ethics. Misleading advertising and cut-prices as well as ridiculously long terms of payment on time sales should be avoided. A house that becomes popularly associated with such practices invariably loses the confidence and the respect of the community.

SATISFACTORY OUTLOOK FOR THE NEW YEAR

FROM a musical standpoint the trade has made real progress during the past year, and this progress will be reflected to advantage during the current year. The talking machine record as a medium for educational work continues to win recognition, aided largely by the fact that it has proven an indispensable factor in the music memory contests that are being operated in all sections of the country. The names of new artists and musical organizations have been added to the record lists and these are calculated to revive and maintain interest in all recordings, particularly of the better class. New issues of popular records have been kept within reasonable bounds and in at least two of the best known lines liberal record exchanges have served to clean out slow-moving stock and leave room for records that promise quicker turnover and, therefore, greater profits.

Reports published in the THE WORLD from its correspondents in widely separated sections of the country have for several months indicated the steadiness of the movement towards trade improvement and a symposium made up of direct reports from manufacturers, wholesalers and retailers in all sections published this month affords an accurate summary of trade feeling which is thoroughly encouraging and speaks well of the spirit of the industry.

Nineteen Twenty-Three is a year of opportunity for the talking machine man who is willing to do his full share of work and not wait for the business to come to him. This much is certain. It may not be a record-breaking year in business volume, but for the first six months at least it is likely to produce results that will stand up well with the best, and, in the final analysis, results will be measured by the volume of constructive energy expended.

IMPORTANCE OF REGULAR COLLECTIONS

AFTER the sale comes the collection and after a great volume of sales such as was registered during the recent holiday period the problem of collection becomes a real one, for the installment accounts are tying up, for more or less lengthy periods, capital that is distinctly necessary to the carrying on of business.

There are those who refuse to heed warning or take advice, and who let machines leave their stores on practically any kind of terms, carrying payments in some cases over a period of eighteen months to two full years. The retailers who follow such a practice are likely to have real cause for worry. On the other hand, dealers who realize the value of the merchandise from a standpoint of replacement and hold out for cash or terms well within reason, will have their financial worries centered only on the problem of getting in regularly the money that is due them so that the holiday accounts are paid out with as little delay as possible.

Good collecting practice does not lie in waiting until two or three payments lapse and then going after the delinquent, but rather in insisting that not only the first but every subsequent payment is met promptly on the day due. The logic of this course lies in the fact that the purchaser is in the beginning shown that he is under a contract obligation to the dealer and is expected to meet that obligation promptly just as he is expected to meet a note at the bank on the date on which payment is due. If, on the other hand, he is allowed to let the first, second or third payment rest for ten or fifteen days after date due, he begins to feel that the

dealer isn't always watching him and that he can become careless.

Prompt collections not only enable the accounts to pay out more rapidly, but cut down materially the number of repossessions for the reason that they give to the purchaser a very substantial equity in his instrument within a period of a few months which places the burden of loss upon him if the instrument is repossessed. A family that has paid five or ten dollars down on a \$100 instrument and uses it three months without making another payment is not worrying about the loss of the machine. If on the other hand the third or fourth month sees the purchaser with a fifty per cent equity in the talking machine, the prospect of losing \$50 stimulates the effort to make payments.

The talking machine dealer who goes after the money due him need have no fear of losing a customer because he happens to ask him for his payments. A definite contract exists between the dealer and the customer. The dealer performs his part by delivering the instrument, and in demanding prompt payment of the customer he is simply asking that the latter fulfill his part of the contract. It is no favor—merely a business obligation.

POPULARITY OF FLAT TOP MODELS

JUDGING from the character of the talking machine demand for the past year or so, the buying public, financially able to do so, is apparently committed to the flat top or console model of machine as compared with the standard upright model. The experience of dealers during the recent holiday season has definitely established that fact because sometime before Christmas in most cases stocks of console models were completely exhausted while there still remained some of the upright type.

It hardly seems as though the period model machine as such has made the impression upon the public hoped for by the producers, probably for the reason that the market for expensive period models, to which great artistic care and attention has been given in an effort to make them authentic, is naturally limited to those who have the money and the taste to have their homes done in distinct period effects.

The console model, however, may be said to have been an outgrowth of the original desire of manufacturers to offer period

THE Talking Machine World offers a prize of ten dollars monthly for the next three months for the best article of from four hundred to five hundred words from a dealer, salesman or traveler setting forth an original and practical idea, or a proven plan, for selling or exploiting talking machines or records, or improving collections. The contests will close on the first day of February, March and April. One dollar each will be paid for all articles which do not win prizes, but which are deemed worthy of publication because of the ideas they contain. The plans or ideas must be practical and tested. Address articles to "Contest Editor, Talking Machine World, 373 Fourth Avenue, New York."

styles as a mean of getting away from the original upright type. and the console model lends itself readily to decorative treatment that would seem out of place in the ordinary horizontal case. The result has been that in a large measure the console model is accepted as a period model. In most cases it follows more or less closely period lines, and except where the intimate details of the period are demanded, fits well into the carefully designed home.

The acceptance of the console model, therefore, may be expected to put the talking machine on a higher plane by making it an attractive addition to the furnishings of the home, as well as a reproducer of music. No one interested in the future of the trade desires to see the talking machine sold primarily as a piece of furniture and secondarily as a musical instrument, but if its musical value is firmly established, and it is offered first on that basis, then its attractiveness from the standpoint of case work increases immeasurably its desirability.

Taking it all in all the advent and success of the flat top or console model is to be accepted as offering a real opportunity to the talking machine trade for increased development, broadening as it does the field of appeal, particularly where the better element among prospective purchasers is concerned.

1923

"Day by day in every way we are getting better and better."

Ask any Pearsall dealer, he'll tell you.

"Desire to serve, plus ability."



10 EAST 39th ST.

NEW YORK CITY

SILAS E. PEARSALL COMPANY
DISTRIBUTORS

THOMAS F. GREEN, President

Retaining Patronage of Old Customers an Important Element of Business Progress

The science of salesmanship does not merely mean the constant adding of new customers, but it does mean, in a great measure, a steady flow of sales to persons who have already become customers of the store through having made a purchase. Too many dealers are turning all of their energies to adding new names to their list of customers and are neglecting a more certain source of revenue from people who have already displayed their confidence in the dealer and his line of merchandise by making purchases.

The above paragraph applies particularly to the talking machine dealer inasmuch as his line is peculiarly adapted to further purchases by former customers. Records offer the dealer this opportunity. This is also true in the case of talking machines to a lesser degree. Of course, it is necessary to bend every energy to securing new customers whom to approach regarding the purchase of talking machines, but it is also a fact that many people who have acquired a cheap machine as a starter may be in the market for one of higher price and better quality or an instrument of different design. For example, if a machine owner possesses an upright model he may be induced to purchase a higher-priced console type of instrument, and along the same line a person who has made his initial purchase of a talking machine of the small portable type may later be interested in a larger model.

Laying aside all consideration of the machine end of the business, however, it is safe to assume that many talking machine merchants are daily losing profits through neglect of customers who already own machines and who offer a fertile and profitable market for records if they

are approached in the proper manner. They are content with merely sending out the monthly supplements and never make any further attempt to increase the record stocks of their customers.

It is also a fact that former customers are antagonized by neglect of this character. In the first place, in every community there are several stores handling machines and records and the average customer does not feel bound to make

As Much Effort Must Be Expended to Retain Old Customers as to Secure the Patronage of Entirely New Ones

purchases from any particular merchant unless that dealer does something in the way of advertising, window displays in connection with the record phase of the business, personal contact or some other form of service which stands out above that of his competitors and makes an impression on the mind of the machine owner which will react in his favor when that man or woman is contemplating the purchase of a record.

Then, too, some dealers antagonize customers

to whom they have succeeded in selling a talking machine in another way. It is a well-known fact that many people are negligent about paying bills and this also applies to instalment payments on machines or any other merchandise purchased in that manner. It is an unwise policy to send out so-called snappy letters to insure the prompt payment of these accounts. Of course, the merchant is entitled to his money, there is no gainsaying that, but if he must write a letter to hasten payments he should at least couch it in such diplomatic language that there is little or no room for offense on the part of the customer.

The average person who buys on the instalment plan, despite all reports to the contrary, is sensitive of the fact that lack of an abundance of money sufficient to cover the payment at the time of purchase necessitated buying in this manner, and a letter from the merchant asking that payments be made promptly, simply because there has been a lapse of a few days in meeting the obligation, is bound to have a detrimental effect on the customer's friendly feeling for the establishment. It would be much better if the collection department, or the person in charge of this end of the business, made personal contact with the customer and gave concrete reasons why it was necessary for the money to be received promptly. At best a letter is a poor substitute for personal contact. In a letter there is none of the friendly inflection which the voice can convey.

Close attention to details such as these will have the effect of strengthening the friendly relations between customer and dealer and pave the way for future sales and the steady upbuilding of the business.



Sherman, Clay & Co.

Victor Distributors on the Pacific Coast

Victrolas Victor Records Victor Accessories

Main Wholesale Depot:
741 Mission Street, San Francisco, Cal.

Branch Wholesale Depots:
10th and Santee Streets, Los Angeles, Cal.
N. W. Corner 13th and Glison Streets,
Portland, Oregon
Oceanic Bldg., Cor. University and Post Streets,
Seattle, Washington
330 West Sprague Ave., Spokane, Washington



5 DISTRIBUTING DEPOTS for YOUR CONVENIENCE

PEERLESS AND THE NEW OPPORTUNITY

SALES IDEAS

For the past few years we have gathered a great quantity of sales ideas. All of them have been tried, and found to be feasible and profitable. Our method of collecting such information has succeeded in making this service department a veritable clearing-house of ideas.

Many of our customers have made valuable use of the sales plans we have been able to present. It is now our purpose to place the services of this department at the disposal of every dealer who enters his name upon our lists.

The wide-awake dealer will find many extra dollars in sales through the aid of this clearing-house during 1923. Send us your name and address today in order to take advantage of this free service.

Phil Ravis



Peerless quality is uniform and dependable. There are no two ways about it.

NOTE: The Large Distribution of Instruments Over the Holiday Season Will Inevitably Be Followed by a Big Demand for Records and Record Albums

In preparing to meet the promising opportunities of the New Year, Peerless is bending all effort towards increased production, efficiency in every department, and the perfection of dealer sales plans.

Our long-standing policy of closest possible co-operation with the talking machine trade will, therefore, be continued on a broad and far-reaching scale through 1923.

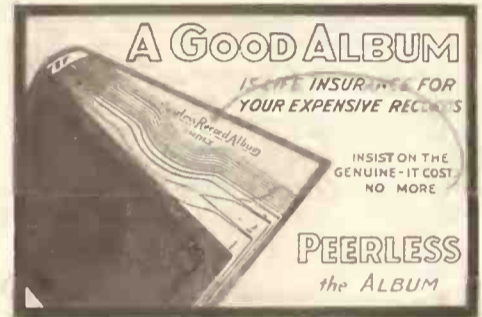

A Postal will bring this sign to you in the next mail—WRITE

PEERLESS RECORD CARRYING CASE



is not only an exceptionally good carrying case, but one you can offer at an attractive price. It will add to your sales for every record owner is a possible purchaser of this fine case.

Manufacturers of:—

- Peerless De Luxe Albums
- Peerless All Grades of Record Albums
- Peerless "Big Ten" Albums
- Peerless Record-Carrying Cases
- Peerless Interiors for Victrolas and Phonographs

- Peerless "Classification Systems"
- Peerless Record Album Sets for All Make Machines
- Peerless Record Stock Envelopes
- Peerless Delivery Bags
- Peerless Supplement Envelopes
- Peerless Photo Albums

It Does Make A Difference What Album You Sell

PEERLESS ALBUM COMPANY

PHIL. RAVIS, President

WALTER S. GRAY
San Francisco
942 Market St.

636-638 BROADWAY
NEW YORK

L. W. HOUGH
Boston
20 Sudbury St.

Necessity for Keeping the Talking Machine Owner's Enthusiasm Alive :: By Frank V. Faulhaber

One thing that the wise talking machine dealer will see to is that those people who have purchased machines from him will get their full share of pleasure therefrom. It represents one move to sell a machine; equally important is the one of keeping the customer satisfied. One talking machine dealer observed: "Many people buy a machine and never take the proper steps to get all possible enjoyment out of it. We should encourage them to keep on buying records so the novelty of the thing will not wear off."

It will not suffice to stop the main efforts when a machine has been sold. For we find that in many instances where considerable selling energy had been exerted to develop a transaction often the new customer had not been thoroughly educated as to the machine's possibilities—in a word, he had not been thoroughly sold.

When a prospect decides finally to buy a machine and a few records the name and address should be obtained for subsequent use. Later your lists can be consulted to determine who have continued to purchase records periodically, and what quantity. Naturally, this suggests the advisability of keeping account of all record purchases being made. From time to time, then, we can remind those who have bought but few new records about the new pieces received and thus encourage them to purchase more. We will also find that some of the machine owners have stayed away entirely; for some reason they have switched their patronage in the music line elsewhere, or, perhaps, some have lost interest in their instruments. At any

rate there is a good deal of valuable information to be procured if the talking machine dealer will but make efforts to get hold of it.

It will not do to stop with the selling of a talking machine. At such times when salesmen are idle it should prove a good move if the slow buyers were canvassed. Object: The reason for the discontinuance of patronage and to encourage more purchases. A salesman with a

*After the Sale Has
Been Consummated the
Real Work of Making
the Customer Remain
Satisfied Commences*

good personality can discuss intelligently the advantages attending the ownership of a talking machine. He will point out that the machine owner should assure himself the utmost in music enjoyment by providing himself with the latest pieces. Encourage your salesmen at the same time to help these prospects in selecting suitable pieces. It is to the talking machine dealer's advantage that interest in the machine is kept alive.

People who buy a talking machine and a few records from you should always be properly followed up. Find out why they are not buying records! There may be the indication that the machine is not being used any more, perhaps only occasionally, when the old pieces are put on again. Naturally, most pieces are popular when they are new; that is why people demand new selections constantly. But there are always those machine owners who have ceased buying records or who buy very few new ones. These people, naturally, cannot be very enthusiastic over the talking machine; they will hesitate to invite their relatives and friends to hear the music, which signifies that many of those relatives and friends will not be afforded the inspiration that should encourage the purchase of talking machines on their part. It can thus be seen how far the loss to the talking machine dealer is reflected.

Let the talking machine dealer see to it that his customers are proud of and enthusiastic regarding their purchases. With the selling of a machine the important work only begins.

CELEBRATE TWENTIETH ANNIVERSARY

T. O. Loveland and J. L. Records, of Brenard Mfg. Co., Manufacturer of Claxtonolas, Celebrate Twenty Years of Partnership

IOWA CITY, IA., January 4.—In celebration of the twenty years of partnership of Theodore O. Loveland and James L. Records in the former Equitable and the Brenard Manufacturing Co. and the present Brenard Manufacturing Co., of this city, manufacturer of the Claxtonola line, Mr. and Mrs. Records and Mr. and Mrs. Loveland entertained more than 100 guests at a dinner at the Hotel Jefferson, followed by a dancing party at the Hotel Burkley on Saturday evening. The guest list included co-workers at the Brenard plant and friends of Mr. and Mrs. Loveland and Mr. and Mrs. Records.

The past, present and future of the Brenard Manufacturing Co. were touched upon in the toast program, of which Mr. Loveland was toastmaster. All speakers, chosen as they were from the various departments—administrative, office force, sales and legal—of the company and from among the social associates of these partners paid tribute, not only to the business partnership of Mr. Loveland and Mr. Records, but to the happy friendship which has existed between these men for twenty years.

On the toast program were talks by Messrs. Records, O. H. Brainerd, Francis W. Kracher, L. Jerome Ingram, G. A. Kenderdine, M. F. Price, Judge O. A. Byington and Senator Charles M. Dutcher, of Iowa City, and W. F. Main, of Cedar Rapids.

Although gifts had been forbidden on this occasion the office force took this opportunity to show its appreciation by making Mrs. Records and Mrs. Loveland each the recipient of a basket of beautiful flowers.

In expression of its congratulations and good wishes the Iowa City State Bank presented two baskets of flowers, one to Mr. Loveland and one to Mr. Records. At the close of the program, silver plaques, suitably inscribed, were given to Mr. Loveland and Mr. Records.

GARVIN & GLESS FILE PETITION

Garvin & Gless, talking machine dealers, 15 Fordham road, New York City, have filed a petition in bankruptcy, listing liabilities of \$3,412 and assets of \$1,332. The members of the firm are Charles J. Garvin and Richard H. Gless.

THIS TONE ARM

Can be used on both
Upright and Portable Machines

SIZES 6½, 7½ AND 8½ INCHES

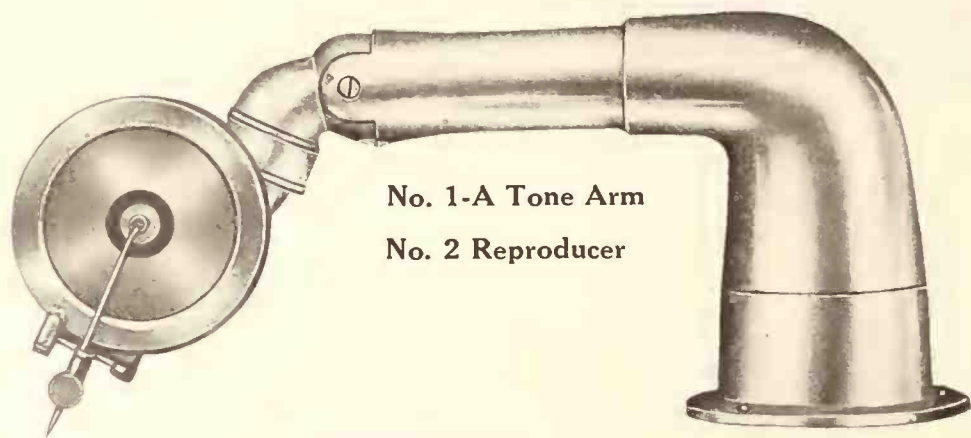

No. 1-A Tone Arm
No. 2 Reproducer

WRITE TO-DAY

Mutual Phono Parts Manufacturing Corp.

149-151 LAFAYETTE STREET

NEW YORK CITY

The Russell Gear & Machine Co., Ltd., 1209 King St., West, TORONTO, CAN., Exclusive Distributors for Canada and All Other British Possessions

"Genius is but the infinite capacity for taking pains"

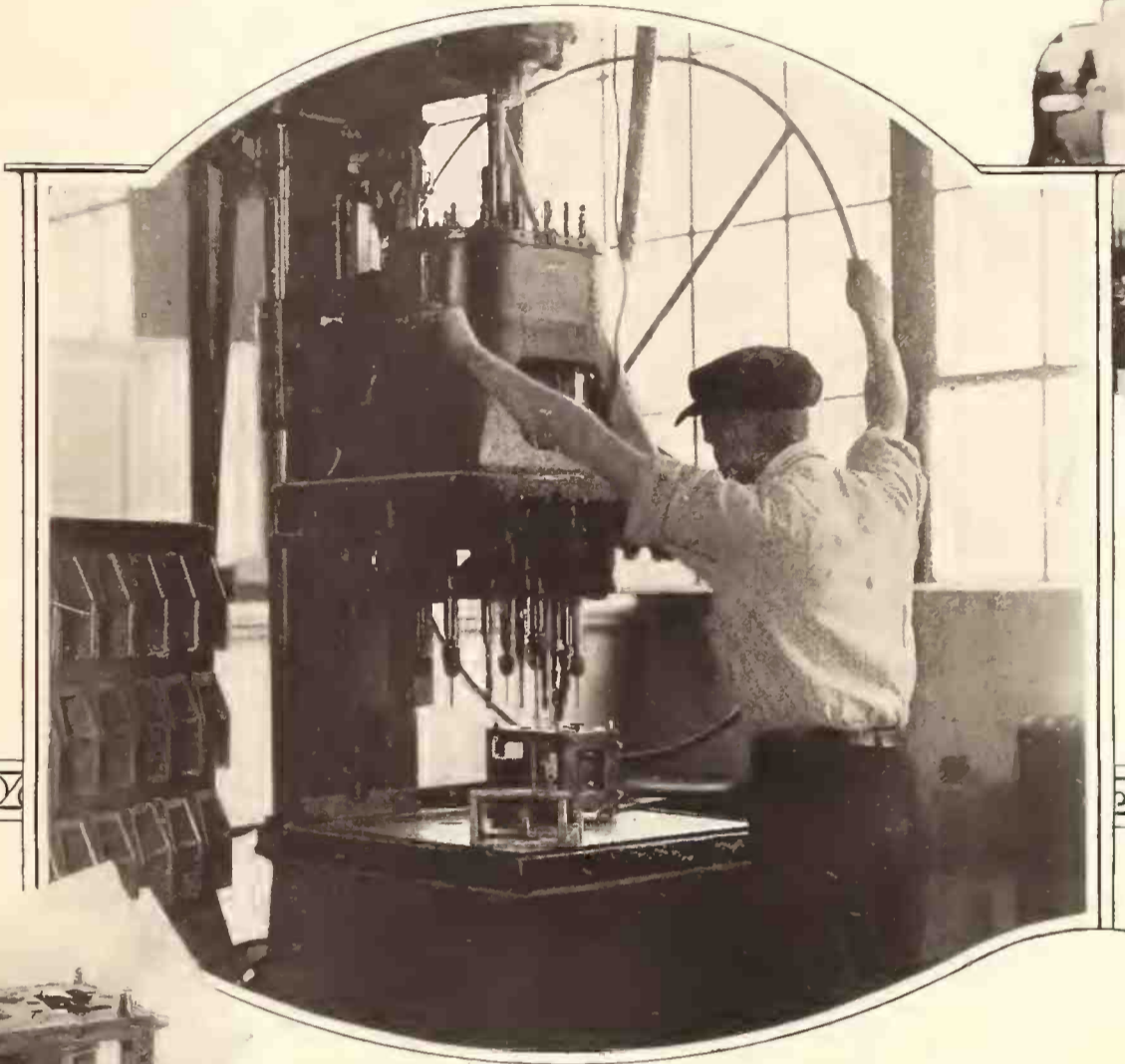

In assembling The Cheney motor the holes drilled and reamed in The Cheney motor frame become the bearing points for spindles and gears. The assembly of The Cheney motor is a very delicate and exacting operation.

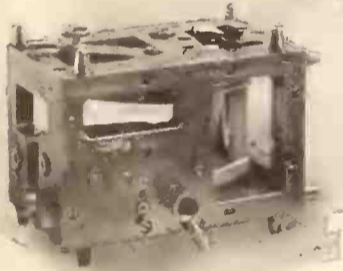

This is the drill jig which makes it possible for the operator of the multiple spindle drill to work so quickly and accurately. It is made from seasoned grey iron and bushed with hardened tool steel and ground bushings, which play the important part of keeping the holes accurately spaced during the multiple drilling and reaming operations.

Through these little holes the drills pass and bore their way into the motor frame housing, combining speed and utmost accuracy.

How 15 Holes of Different Sizes are Drilled in Less than a minute in a Cheney Motor Frame

It is a cardinal principle in The Cheney motor factory that accuracy must never be sacrificed for speed. That does not preclude the use of the most modern inventions for cutting down production costs.

Illustrated above is a multiple spindle drill which makes it possible for an operator to drill fifteen holes of different sizes in a Cheney motor frame in less time than it takes to tell it. Every hole

is absolutely accurate to the thousandth of an inch, not only in diameter but in spacing as well.

It is through the use of such efficient methods as this that The Cheney Talking Machine Company has been able to produce instruments with a reputation for highest quality, and yet to keep prices at a level no higher than that of the ordinary phonograph.

THE CHENEY TALKING MACHINE COMPANY • CHICAGO

The CHENEY

THE MASTER INSTRUMENT

"The Longer You Play It, the Sweeter It Grows"



Analysis of Conditions Existing in Stores Which Help and Retard Growth :: By F. H. Williams

Suppose that a careful observer went around to the talking machine stores in your city, Mr. Dealer, and then made a report on conditions in stores that were not getting the business and a similar report on conditions in stores that were getting the business. Wouldn't such a report be of immense value in helping you to determine what you should do and what you should not do in your own establishment in your endeavors to get more patronage?

Recently a skilled investigator made an inspection of the stores in a Middle Western city and what he found out on this tour of inspection will, unquestionably, be of interest and help to other dealers.

Here's the investigator's market report:

Stores That Were Not Getting the Business

Mr. A's Store: Good location near one of the busiest corners in the city. Plenty of people passing the store at all hours of the day. The stores nearby were enjoying a good trade—these establishments being drug stores, clothing stores, women's wear establishments, etc. Mr. A's store, however, had only one customer in it the first time I visited the store and on return visits at various times there were never more than three customers in the place at any time. It is evident from this and from statements made by Mr. A. and neighboring merchants that his establishment is slipping and that he isn't getting anywhere near the patronage that he should get in view of his excellent location.

Reasons Why Mr. A. Isn't Getting the Business: The most striking thing about this store is its dinginess. The counters are soiled and dingy, the cases are dingy and in one or two places there was broken glass in the cases and the salespeople and the proprietor himself all look dingy. Also the store is very poorly lighted, the window displays are almost never changed and the whole store is unattractive and unappealing. The store might, perhaps, get by in spite of all this but for the fact that neither the proprietor nor the salespeople manifest anything more than the faintest interest when a customer does come into the establish-

ment. Is it any wonder this store is slipping?

Mr. B's Store: This store is located on the second floor of a building in the center of the city above a five and ten-cent store. The location is good and the store is well advertised by Mr. B. so that people know where it is.

But the business formerly enjoyed by the store is constantly slipping away from it and it is the opinion of the investigator that the trouble is due to overanxiety on the part of Mr. B. and his employes to make sales. Every time a patron comes into the store both Mr. B. and his salespeople fairly hang about the

Compare the Methods of the Successful and Unsuccessful Merchants and Check Up With Your Own Plans

neck of the customer urging him to buy more records or to buy more needles or to get a talking machine for some friend or relative. It is just about as much as a customer's life is worth, in fact, to buy a single record from this store, and when the customer does succeed in this real feat the grieved looks on the faces of the proprietor and of the salespeople because the customer didn't buy a high-priced instrument and about fifty dollars' worth of records make the customer feel like a criminal when he departs and also make him feel that he never wants to patronize the store again. Which, of course, is mighty poor business for the store and which leads the investigator to feel that it is no wonder the store is slipping.

Mr. C's Store: Fair location; a block away

from the main thoroughfare of the city. Low overhead should make this store show a good profit, but it is not doing so because the proprietor doesn't keep his stock up and because he never keeps his promises about making deliveries and sending in orders for records and machines which he doesn't have in stock. For instance, the investigator went to this establishment and asked for a record which had just recently been released and which was quite popular. The store didn't have it in stock, but the proprietor said he'd send for it and get it in the store within a week. The week went by and it developed that the proprietor had forgotten to send in the order. Another week and the record had not yet arrived and it was fully three weeks before the record was finally secured at this store. Interviews with patrons of the store developed the fact that this is the way the proprietor treats all customers. No wonder his business is rapidly getting away from him.

Stores That Are Making Good

Mr. X's Store: This store is located about a block and a half from the main thoroughfare of the city on a good shopping street. The store itself is small, but is very attractive and modern in appearance and is always well lighted at all times. The most interesting feature about this establishment is its constant business aggressiveness. The store is always up and after business every day in the week and every week in the year. The store uses newspaper advertising quite strongly in going after more business and puts on a free concert one evening each month to which all people are invited free of charge and at which no goods are sold, and during the noon hour it has a standing invitation to all the office people in the city to come to the store and listen to a noon-hour concert free of charge. This noon-hour stunt is quite a thing with the office people in the immediate vicinity of the store and there is scarcely ever a noon, especially when the weather is bad, when there is not a good throng of people in the store listening to the music rendered by a large talking machine placed in the center of the sales floor. There are plenty of chairs around so that the music lovers don't have to stand up. This noon-hour concert stunt puts the store in close touch with people in its neighborhood and helps it greatly in making sales.

Mr. Y's Store: Mr. Y's store is a second-story establishment in a good location near the center of the city's shopping district. The store attracts attention to itself each afternoon by staging an outdoor concert by means of a sound magnifier placed on the sill of one of its display windows. This concert attracts a lot of attention and makes folks talk and thus gives the store a considerable amount of worthwhile free advertising. Also this store has made an arrangement with the first-floor tenants of the building in which it is located whereby these first-floor merchants every now and then give a window display of some of the store's talking machines and records with placards urging folks to climb the stairs and buy instruments and records at the store. In return for this the store has signs up in its sales room urging its patrons to patronize the first-floor merchants. In this way the store gets the benefit of first-floor window displays without having to pay first-floor rentals. All of which helps the store considerably in doing a business which brings in a good profit each year.

Mr. Z's Store: This store is located in the middle of a block on one of the main thoroughfares in the city. There are a very large number of people passing the store every day and

Let the Sign of the

CLEAR AS A BELL
Sonora Bell

*Ring in a Prosperous
New Year for You*

Greater City Phonograph Co., Inc.

311 Sixth Avenue, New York

Mr. Z. gets a lot of patronage from them. The most interesting business-building feature of this store is the fact that Mr. Z. changes his window displays twice a week and makes his displays just about three times as attractive as the displays in many music stores. "This frequent change of the window displays in my store is the least expensive advertising in which I could engage," says Mr. Z., "and it is also the most effective advertising. It makes my store always look new, lively and interesting and it gets the attention of the prospects right at the point where I am doing business and where few steps are needed to bring them inside and up to my counters. My window displays are worth every bit of the time and trouble they take."

Aren't there some good suggestions in all this for YOU, Mr. Merchant?

CARE IN SHIPPING ABROAD

Importance of Packing and Careful Markings Necessary to Insure Safe Delivery

While the talking machine trade has won a fairly good reputation for packing and shipping, yet too much care cannot be exercised, particularly when shipments are made abroad. Iron straps or bands not only protect the packages effectively, but also add strength to the containers. Bills of lading and shipping orders should be prepared carefully. Consignee, destination, route, number, description and packing should be plainly indicated. Each package should be legibly marked with the name of the consignee, destination, route and street address if in the city. The name and address of the shipper should appear on each package preceded by the word "from." This insures prompt notice in case shipment is refused or unclaimed.

*** THRIFT BANKS PROVE POPULAR**

The Brunswick-Balke-Collender Co. has been receiving a large number of letters from Brunswick dealers located in all parts of the country testifying to the fact that the Brunswick thrift banks proved exceedingly popular and demonstrated a remarkable ability to help Brunswick dealers increase their business and local interest in their respective establishments. Testimonials of a similar character and of an equally enthusiastic nature have been coming in to the Brunswick offices bearing on the good-will series of prospects' letters, which the Brunswick Co. recently offered to its retailers as a dealer aid. Both these dealer helps were unusually effective as sales stimulators.

Four-Minute Conference on Business Topics

No. 9—Your Patronage and How to Increase It

[This is the ninth of a series of four-minute conferences on topics of direct interest to business men in the talking machine trade which have been prepared for this publication by Lester G. Herbert.—EDITOR.]

It has been remarked recently by an economic authority that what American business needs at the present time to bolster it up and to send it rolling merrily ahead is not more money, but a better and more persistent grade of sales effort.

This is an opinion worthy of profound and careful thought. It was repeated to the business manager of a department store employing one hundred people. The manager snapped back quickly, "That is all bosh."

The same thought was repeated to a young woman in charge of a counter directly in front of the main entrance. She nodded thoughtfully and said: "That is true. There are times when a dozen people an hour do not come through our doors. Sometimes for a morning or an afternoon the majority of our force is only busy in a makeshift manner—one which does not directly bring money to the firm."

Again the same opinion was repeated to the proprietor of a specialized retail establishment selling only one line. He laughed, shrugged his shoulders, and said indifferently, "There is nothing to it."

Later one of his clerks was approached casually and asked what he thought of that selling idea. He said: "There is no doubt about it. The boss is in a rut and seems to think that some miracle is going to happen to bring a lot of money his way some sweet day. He doesn't seem to realize that he must get up and hustle—and it is now or never!"

The president of a big manufacturing concern was interviewed and his judgment asked on the matter. He looked thoughtfully out of the window a few moments, then smiled and replied: "What you have stated is sound and sane. It is a fact that we could market more of our goods if our customers would do their part in selling—and they and we would both be more prosperous. We are trying as a firm to teach our salespeople to realize the value of selling the idea of service first and of showing wherein the advantage lies for the customer if he will do his part. Then sales of the goods we make will follow naturally. Yes; a better and more intelligent and a more energetic sales effort is needed everywhere in American business to-day. Give us that and capital will be

forthcoming as a natural result. We must speed up turnover!"

A great many business people have not yet grasped the idea that there is a distinct and intimate relation between turnover and the firm's share of the profits. Profits are not made on each individual until made or sold—except in theory. In reality complete invoice costs and overhead expense must be met before the firm comes in for any dividends at all.

Many times the firm's part of the profit is all tied up in leftovers or unsold stock. This means that there is not enough cash on hand for reinvestment. Clean, active business demands complete turnover that the firm may have its share of dollars and cents to use. All too many firms neglect turnover and only handle enough cash to pay for supplies and overhead expense. A better sales effort means a complete turnover and consequently more money.

A better sales effort is possible in every firm which has not reached 100 per cent efficiency—and very few have!

A better sales effort calls for increased "know how," wise, persistent publicity, more personal interest and the concentration of will-power upon a possible goal of achievement. We can if we will! Let's know what we want to do and do it!

SIoux CITY FIRM ADDS "TALKERS"

SIoux CITY, IA., January 2.—The Lindholm Furniture Co., of this city, has installed a talking machine department on the main floor of its handsome store. Up-to-date fixtures and four soundproof record demonstration rooms have been constructed and the department compares favorably with any other in this section. A complete line of Victor talking machines, Brunswick phonographs and records is handled and an aggressive merchandising policy has been formulated.

RADIO TO ADVERTISE RADIO

WASHINGTON, D. C., January 6.—A radio receiving station is being installed in the Kiefer Music Store on East Fourth street as an advertisement for the Zenith long-distance radio, for which the Kiefer Music Store has the agency. The aerial wires have been suspended high above the roof of the building occupied by Kiefer's store.



'PHONE FITZROY 3271-2-3



A New Year's Resolution

Resolved "That 'Ormes Really Means Exceptional Service' will be increasingly apparent and proportionately more valuable to Victor retailers during 1923."

Who's your Victor jobber?

ORMES, Inc.

15 West 37th Street

New York

Columbia

*Acclaimed
by everyone
an Unqualified Success*

IMMEDIATELY following our October 31st announcement, in the newspapers, the public everywhere accepted our invitation to investigate Columbia New Process Records. At once, they went to Columbia Dealers' stores and demanded the most exacting proof. Surprised and delighted, they have been quick and generous in their praise of its surface quietness and increased musical charm, all due to the reduction of scratch and scrape to practical inaudibility.

The superiority of Columbia New Process Records, over every other present-day record, in any classification of music, is clearly demonstrable.

It is easy for you to convince yourself of Columbia's astonishing new quality. Go to your Columbia Branch and listen to Columbia New Process Records and prove to your own satisfaction that Columbia's discovery gives the world an infinitely better phonograph record.

We are sparing no effort to broadcast the message of this wonderful record improvement. We have ready for Columbia Dealers attractive advertising material that is a powerful magnet between our national advertising appeal, their stores and the public. See the nearest Columbia Branch.

COLUMBIA GRAPHOPHONE COMPANY
New York



New Process Records

R. L. Tamplin, of San Bernardino, California, says the announcement advertisement produced the largest record day the store ever had.

Detroit Columbia Branch reports the statement of one dealer that a "hard-boiled" purchaser of a well-known record, who considered all other records absolutely no good, responded to our advertisement and purchased three New Process Records; the next day he returned and bought more.

Mr. Standke, of the Grafonola Shop, Kansas City, states many old customers who had not been in his store for months came in and bought New Process Records.

Fleischer Brothers, of Cleveland, say: "New customers are coming in to our store every day to buy New Process Records. They say the records are wonderful. New Process Records are making Columbia fans of people who formerly purchased other makes."

John Aroks, of Racine, Wis., had more people interested in high-grade records come into his store the day following the advertisement than ever before in his business life.

Mr. Hein, of Waterson, Berlin & Snyder, Chicago, says hundreds of people have come in asking for New Process Records.

Calhoun, of Decatur, Ill., tells us of a resident in his city owning 1500 records of all makes who says New Process Records are the best in his whole collection.



This illustrates the laminated construction of the New Process Columbia Records.

A—illustrates the much smoother playing surfaces which are made of a new substance over which the needle travels almost inaudibly.

B—illustrates the much harder centre core which resists warping.

The ALBUM method EXCELS all other RECORD FILING systems EVER TRIED



SELECTING THEIR FAVORITES

NATIONAL PUBLISHING CO., 239 S. American St., PHILADELPHIA, PA.

New York Office, 54 Franklin Street, Telephone, Franklin 1227, James E. Maguire, Representative

To the Trade:

Our Record Album factory—all or any part of it—is at *your command*. Hundreds of customers can and will gladly testify as to the good quality of our production.

Our large and growing business is due to satisfied customers and repeat orders.

Imprint (firm name or trade mark) stamped on covers if desired when orders are sufficiently large to justify it.

OUR ALBUMS ARE MADE TO CONTAIN VICTOR, COLUMBIA, EDISON, PATHE, VOCALION AND ALL OTHER DISC RECORDS



THE PERFECT PLAN

SOME HINTS ON ADVERTISING

Instructive Pointers Contained in Article by Dick Thompson, Advertising Manager of Daynes-Beebe Music Co., Salt Lake City

An instructive and interesting article on advertising by Dick Thompson, advertising manager of the Daynes-Beebe Music Co., Salt Lake City, recently appeared in the Tribune Service Bulletin, a local newspaper. Some of the points brought out reflect the authoritative views of this experienced advertising manager and they are, therefore, reproduced herewith:

"What is advertising? It is a prescription to remedy a business illness if one exists, or to tone up trade and keep it moving even if your establishment is already up and coming.

"Like the medicine the doctor gives you, advertising is subordinate to the will power and the mental attitude of the personnel of your entire organization, from the boss down to the janitor.

"What the average store needs mostly is not so much more advertising, but a better understanding and a better backing up of the copy it is already running.

"There is a limit to the duty of advertising. That duty has been faithfully done when the customer comes to your store either convinced or not convinced. The very fact that the customer has responded indicates that he has willingly placed himself at your distinct advantage, for he comes to your establishment and you meet him on your own chosen ground, either ready to buy and eager to buy, or perfectly willing to be shown and convinced if you only display the desire to serve him courteously and intelligently.

"How many of your salespeople are like the one who, when asked how his firm's advertising was pulling, brilliantly replied, 'I ain't seen any of it.'

"Whose fault was that? Wasn't it the height of folly for that firm to try to sell the public their product through advertising, when their own salespeople weren't even familiar with the message they were sending out?

"Suppose a prospective buyer shot a question at that salesman covering a selling talk dwelt upon in one of the ads? How would the salesman answer? How much confidence would the prospect have in either the advertising or the house or the salesman?

"A word, a look, a gesture by the clerk or salesperson may often undo thousands of dollars' worth of advertising effort, or, on the other hand, it may prove a powerful ally that will make coming to your store a habit instead of an experiment. Back up your advertising and your store will never have to back up."

TALKING MACHINE TRADE IN CHILE

United States Supplying Chilean Market With Bulk of Talking Machines

The United States has practically a monopoly of the talking machine business in Chile. A few German phonographs are in use there, but the business is negligible. The northern region of Chile has been a good market for musical merchandise, especially talking machines, records and sheet music and dealers have had a profitable business with the population of the mining towns in the interior of this country. This trade has now decreased considerably on account of the exchange rate, the increase of customs duties and the emigration of the people of the mining camps and towns who were the chief buyers of gramophone music.

A new talking machine store has been opened at 211 McMillan street, Cincinnati, O., by Moore Bros.

DEATH OF COLUMBIA ARTIST

John J. Fisher, Pioneer Columbia Artist, Passes Away in Bridgeport

BRIDGEPORT, CONN., January 2.—John J. Fisher, 56, former Columbia artist and of late years insurance and real estate dealer, passed away recently at his home, 1907 Park avenue, following an apoplectic shock.

Mr. Fisher was widely known in Bridgeport, having been a resident for twenty years. He was born in Baltimore, Md., and came to this city with the Columbia Graphophone Co. as a singer. He possessed a fine tenor voice and gained national recognition as one of the pioneer singers for phonographic records.

Besides his widow, Maude C. Fisher, two brothers, William H. and George M. Fisher, of Washington, D. C., survive him.

NEW RADIO ORGANIZATION

A new organization known as the Independent Radio Manufacturers, with offices at 165 Broadway, New York, was formed recently. Walter Russ, of Pennie, Davis, Marvin & Edmonds, attorneys for the new Association, states that the incorporation of the organization marks the first important step toward clearing up the atmosphere surrounding the many patents and counter-patents incidental to the radio industry to-day.

FLOYD JENNINGS IN NEW POST

ATLANTA, GA., January 3.—Floyd Jennings, who is well known in local musical circles, now is with the Goodhart-Tompkins Co., on Peachtree street, being employed in the talking machine department of this firm. Mr. Jennings has made many friends in Atlanta since he came here from Dawson little more than a year ago.

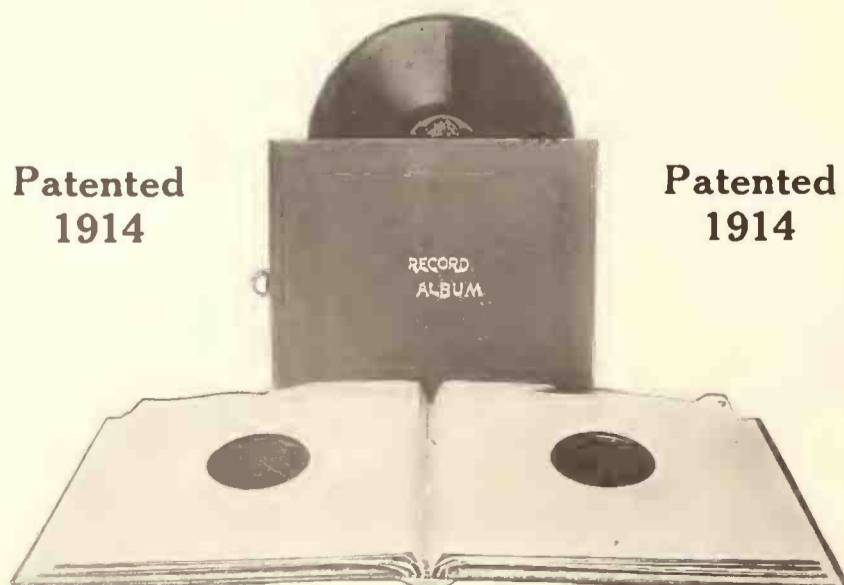

1923 IN TURNING OVER A NEW LEAF

of a record album pay particular attention to the way that leaf is held in position. There is only one way to anchor these leaves which will absolutely insure against any possibility of falling out or wearing out at the point of anchorage. That way is the "Boston Way" and is only found in the famous Boston (patented 1914) albums. If you are not familiar with Boston albums you are doing yourself an injustice. Write for a sample.

BOSTON BOOK COMPANY
501-509 PLYMOUTH COURT CHICAGO, ILL.

VINCENT LOPEZ

AND HIS HOTEL PENNSYLVANIA ORCHESTRA

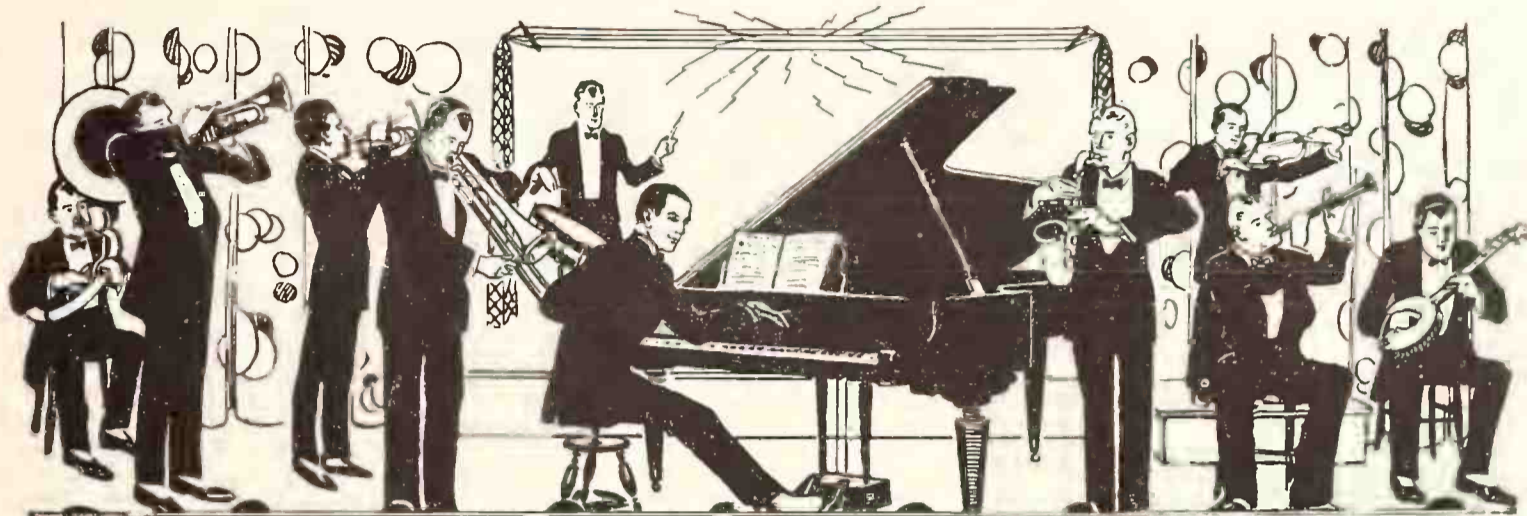

Acclaimed by thousands!

Vincent Lopez and His Hotel Pennsylvania Orchestra are the season's greatest sensation!

At Keith's Palace—where vaudeville's coolest critics pass judgment on all performers—their reception was so great and the audiences' approval so marked that they were obliged to play at this one house for nine consecutive weeks! Then, after sensational success at Keith's Colonial, Orpheum, Bushwick, Riverside, Alhambra, and Royal Theatres, popular demand brought them back again to the Palace, where they stayed for two more weeks!

No other dance orchestra in the history of vaudeville has met with such phenomenal success. Their vivid interpretations and renditions of modern dance music have won for them the praise and admiration of thousands.

Okeh Records by Vincent Lopez and His Hotel Pennsylvania Orchestra are the fastest selling dance records in our catalogue.

We are pleased and proud to inform you that Vincent Lopez and His Hotel Pennsylvania Orchestra record exclusively for

Okeh Records

The Records of Quality

SOME OF LOPEZ'S LATEST HITS

- | | | | | | |
|------------|---|---|------------|---|---------------------|
| 4736 | { | AWAY DOWN EAST IN MAINE | 4706 | { | HOMESICK |
| 10 in. 75c | | SWANEE SMILES | 10 in. 75c | | TOOT, TOOT, TOOTSIE |
| 4707 | { | TURTLE DOVE | 4673 | { | COAL BLACK MAMMY |
| 10 in. 75c | | WHERE THE VOLGA FLOWS | 10 in. 75c | | TRICKS |
| 4660 | { | NEATH THE SOUTH SEA MOON | 4638 | { | PARADE OF THE |
| 10 in. 75c | | JUST BECAUSE YOU'RE YOU— THAT'S WHY I LOVE YOU | 10 in. 75c | | WOODEN SOLDIERS |
| 4662 | { | DANCING FOOL | 4664 | { | AIDA |
| 10 in. 75c | | DIXIE HIGHWAY | 10 in. 75c | | ANITRA'S DANCE |



General Phonograph Corporation

OTTO HEINEMAN, President

25 West 45th Street

New York City



YERKES' ORCHESTRA ON TOUR

Yerkes S. S. Flotilla Orchestra Completing Successful Vaudeville Tour Which Brought Excellent Business for Vocalion Records

The Yerkes S. S. Flotilla Orchestra is just bringing to its close a most successful tour of the country, appearing in the leading vaudeville theatres with great success. They have appeared in Minneapolis and St. Paul and the accompanying photograph shows the organization in the lobby of the State Theatre in Minneapolis, where a strong tie-up with the Vocal-



Members of Yerkes S. S. Flotilla Orchestra ion record was made, through the medium of the Stone Piano Co., local Vocalion Red Record distributor.

The Yerkes Orchestra has also appeared in St. Louis, Chicago and a number of other cities and has so arranged its program so as to play on each occasion numbers which it has recorded for the Vocalion.

The appearance of the orchestra on every occasion served to stimulate the demand for Vocalion records to a most substantial degree, particularly where local dealers and distributors seized the opportunity of featuring the appearance of the orchestra.

PLEA FOR TALKING MACHINES

Government Official Takes Verbal Fling at Landlords in Washington Who Would Bar Talking Machines in Apartments

It would seem a far cry from Postmaster General Hays' "humanizing" policy, as applied to the postal employes, to a discussion of leases submitted to tenants in which the lessees were asked to give up their phonographs, remarks the Washington Star. But the bright light of humanity, as exemplified by Mr. Hays, brought the two together all right.

An official of the Government was talking about those leases in which talking machines are classed with dogs, cats and parrots.

"What the people who made out those leases need is more of the spirit that moves Mr. Hays, more of the desire to look at the other fellow's side of things," he said.

"They would banish the immortal voice of the great Caruso, singing on, though the singer is no more; the art of the great pianist Rachmaninoff; of Kreisler, the violinist; the wonderful work of Schubert, Beethoven and other masters.

"They need to learn that the modern talking machine, properly used, is a true source of true music and that 'the man who has no music in his soul is fit for treason, stratagems and spoils,' indeed."

BUSH & LANE ADD TO CAPITAL

HOLLAND, MICH., December 30.—The Bush & Lane Piano Co., of this city, has increased its capital stock from \$1,000,000 to \$1,500,000, according to a recent announcement.

Theo. Karle, exclusive Brunswick artist and well-known tenor, is a lineal descendant of Andrew Jackson. The fact became public recently when Mr. Karle was invited to become a member of a society composed of descendants of United States Presidents.

OUR EXPORTS OF TALKING MACHINES

Exports and Imports of Talking Machines and Records Show Increasing Tendency as Compared With Last Year—Our Buyers Abroad

WASHINGTON, D. C., January 10.—In the summary of exports of the commerce of the United States for the month of October, 1922 (the latest period for which it has been compiled), which has just been issued, the following are the figures on talking machines and records:

Talking machines to the number of 5,923, valued at \$251,851, were exported in October, 1922, as compared with 3,257 talking machines, valued at \$139,429, sent abroad in the same period of 1921. The ten months' total showed that we exported 42,356 talking machines, valued at \$1,544,411, as against 30,231 talking machines, valued at \$1,427,112, in 1921.

The total exports of records and supplies for October, 1922, were valued at \$130,265, as compared with \$223,105 in October, 1921. The ten months ending October, 1922, show records and accessories exported valued at \$873,954; in 1921, \$1,869,788.

The countries to which exports were made in October and the values thereof are as follow: France, \$534; United Kingdom, \$7,829; Canada, \$107,648; Central America, \$3,790; Mexico, \$14,141; Cuba, \$2,659; Argentina, \$19,601; other South America, \$13,658; China, \$4,950; Japan, \$27,175; Philippine Islands, \$3,989; Australia, \$11,496; Peru, \$7,986; Chile, \$4,593; other countries, \$21,799.

In the above report the imports are not in-

cluded and this is explained by the Bureau of Foreign and Domestic Commerce who inform The World that "Only the exports of domestic merchandise by articles and principal countries are published at this time on account of the delay in the import reports. The corresponding statement of imports will be published when the delayed reports are received."

LEASES SPACIOUS NEW QUARTERS

New York Album & Card Co. Concludes Arrangements for Additional Space

The New York Album & Card Co., New York, manufacturer of Nyacco albums, recently signed a lease for the entire fourth floor of the building at 23-25 Lispenard street. This is in addition to its other space and was made necessary by the increased production plans for 1923. Production is also being speeded up in the Chicago factory of the company. Max Willinger, president of the company, reports that the stock of raw materials in his factory is running low and in a recent warning to the trade stated that with the rising market in raw materials new purchases would probably have to be made at a higher price. However, in the meantime Mr. Willinger is protecting his many friends in the trade on the former price.

Start the new year right by setting your business house in order and making plans to make 1923 a banner year from the standpoint of sales volume and profits. However, if a resolution is made it should be kept.

LIBROLA (Library Table-Phonograph)

You should see the **\$150⁰⁰** (retail price) Model similar to the one below.

Write for illustrations and net prices.

Immediate Shipment



Seaburg Mfg. Co.
Jamestown, N.Y.

No. 250T, List Price \$195.00
Usual discounts to dealers
48"x28"x31" high. Finished all around
Genuine Mahogany, Walnut or Oak

The Biggest Value on the Market. A Trial Order Will Convince

The Sonora Period Models Have Created a Class of Their Own



Queen Anne



Marquette



Canterbury

Wherever the public prefers periods—and that is nearly everywhere today—Sonora's beautiful period models have *created* a demand that has put our factories to the hardest test.

Now, after Christmas, the *demand still exists*. Thousands of purchasers who could not get Sonoras last month are going to make January sales leap for Sonora dealers.

The period is far less a seasonal sale than the upright. Its character as a beautiful piece of furniture makes the demand for it continuous. The stunning Sonora period consoles—like the beautifully clear Sonora tone—are in a class by themselves. Sell them in 1923.

**SONORA PHONOGRAPH
COMPANY, Inc.**

George E. Brightson, President

NEW YORK: 279 BROADWAY

Canadian Distributors: SONORA PHONOGRAPH, Ltd., Toronto

THE INSTRUMENT OF QUALITY
Sonora
CLEAR AS A BELL 

The Highest Class Talking Machine in the World

Get in touch with the Sonora Distributor named below, who has charge of your territory, and learn particulars of the liberal Sonora proposition.

State of New York

with the exception of towns on Hudson River below Poughkeepsie and excepting Greater New York.

Gibson-Snow Co.,
Syracuse, N. Y.

State of New Jersey.

Sonora Sales Co. of New Jersey,
605 Broad St., Newark, N. J.

State of Indiana.

Kiefer-Stewart Co.,
Indianapolis, Ind.

State of Nebraska and Western Iowa.

Lee Coit Andreesen Hardware Co.,
Omaha, Nebr.

The New England States.

Sonora Phonograph Co. of New England,
221 Columbus Ave., Boston, Mass.

Washington, California, Oregon, Arizona, Nevada, Northern Idaho, Hawaiian Islands.

The Magnavox Co.,
616 Mission St., San Francisco, Cal.

Southeastern Part of Texas.

Southern Drug Company,
Houston, Texas.

Alabama, Georgia, Florida and North and South Carolina.

Southern Sonora Company,
310-314 Marietta St., Atlanta, Ga.

States of Montana, North Dakota, South Dakota, Minnesota and Northern Iowa.

Doerr-Andrews-Doerr,
Minneapolis, Minn.

Missouri, Northern and Eastern Part of Kansas, and 5 counties of N.E. Oklahoma.

C. D. Smith Drug Co.,
613 Arcade Bldg., St. Louis, Mo. St. Joseph, Mo.

States of Colorado, New Mexico and Wyoming east of Rock Springs.

Moore-Bird & Co.,
1751 California St., Denver, Colo.

Utah, western Wyoming and southern Idaho.

Strevell-Paterson Hardware Co.,
Salt Lake City, Utah.

Illinois and Eastern Iowa.

Sonora Phonograph Co. of Illinois,
720 S. Michigan Ave., Chicago, Ill.

Wisconsin, Upper Michigan.

Yahr & Lange Drug Co.,
Milwaukee, Wis.

Eastern Pennsylvania, Maryland, Delaware, District of Columbia and Virginia.

Sonora Co., of Phila., Inc.,
1214 Arch St., Philadelphia, Pa.

Western Pennsylvania and West Virginia.

Sonora Dist. Co. of Pittsburgh,
505 Liberty Ave., Pittsburgh, Pa.

All of Brooklyn and Long Island.

Long Island Phonograph Co.,
150 Montague St., Brooklyn, N. Y.

New York City, with the exception of Brooklyn and Long Island. Also

Counties of Westchester, Putnam and Dutchess; all Hudson River towns and cities on the west bank of the river, south of Highland; all territory south of Poughkeepsie.

Greater City Phonograph Co., Inc.,
311 Sixth Avenue, New York.

Co-operative Advertising Brings Patronage to a Coterie of Live Dealers :: By W. Bliss Stoddard

The "neighborhood" co-operative advertisement movement is spreading to all lines in all parts of the country. We have heard for some time in the street cars and on billboards "Patronize your neighborhood grocer" and "Consult your neighborhood druggist." It remained for a group of St. Louis merchants, however, to get together and start a co-operative campaign to induce the public to patronize their neighborhood Victor dealer. Their ad was headed: "Stop in at Your Neighborhood Victrola Store." In a box at one side they said: "Your Neighborhood Victrola Store—It's one of these eight—get acquainted with it. Bauer Music House, Wellston Talking Machine Co., Deeken Music Co., DeMerville Piano Co., Daniel G. Dunker Piano Co., Glaser's Music Shop, Lehman Music House and Todd Jewelry & Music Co." All of these are firms located in the residential districts of St. Louis and the address of each was given after the name. The idea was to get people in the habit of dropping into the store near their home instead of going downtown to make their purchases of records and supplies. This side box was run in all of their ads, but the balance of the notice was changed in each issue, there always being something of timely appeal. At Valentine time they featured a number of love ballads; St. Patrick's Day, Irish songs; Easter, hymns and selections from the oratorios; at Flag Day, patriotic music. Several of the firms interviewed declare it is the most satisfactory form of advertising they have ever used, as it is inexpensive, timely and gets their message before the public more effectively than they could do alone.

How a Live Store Gets After Trade

It is not often that you hear of a drug store putting in such an elaborate talking machine department that it is considered worthy of a full-page ad, but McRoberts Drug Store, Lancaster, Ky., is the happy exception. According to the manager the only way to make a talking machine department a success is to give it plenty of space and plenty of publicity. This drug firm carries an average of thirty-five models, in six different finishes, in stock and finds that the sight of so many machines acts as a stimulus to buying, as it makes customers think that in such a complete stock they will be pretty sure to find a model to satisfy them. "Of course we do not

make a practice of running full-page ads of our phonograph department," said the manager, "but at stated seasons we find it good policy to do so. At these times we always dwell on the advantage of enjoying the instrument while paying for it. We stock good grade instruments and not many in a small town can pay cash for same, so we feature the monthly payment plan and find that it works to our advantage to do so. In fact, it is better for us than if our customers paid cash, for it brings the people to our store at regular intervals, and they are nearly always sure to see something else of which they stand in need. In the Spring we appeal to the brides, at graduation time to

will say, "Gee, that's great! Play it again!" Can you afford to be without one? Come in to see them to-day. Remember a dollar down puts a Grafonola in your home during this sale."

How Sales of Exercising Records Increased

The talking machine department of Ayres & Son, Indianapolis, Ind., recently put on a stunt that greatly increased the sale of their exercising records. This time, instead of watching a demonstrator go through the exercises to the commands of the machine, the "patients" did the exercises themselves. The demonstration was for women only. The ad read, "Why be fat? Join our flesh-reducing classes and take off some of the 'too, too solid flesh.'" For one week the firm employed a physical culture teacher, who taught all would-be-thin women how to take off flesh to the sound of music. Classes were held each morning and afternoon in a room adjoining the phonograph department. Women in gymnasium suits lay in rows on the floor and kicked and swung to music, while the coach gave first aid to many winded patrons. The demonstration was a great success and after the women had seen how easy it was to do their own reducing scores of the records were purchased in order that the practice begun so auspiciously in the Ayres gym might be brought to a happy conclusion in the seclusion of their own boudoirs.

Some Clever Jingle Advertising

Trorlicht-Duncker, St. Louis, Mo., have been doing some clever jingle advertising lately, and one of their "Bruns-Wicked Ballads," while designed to catch the holiday trade, would do equally well for Easter, graduation or birthday suggestions:

As Christmas draws near,
It's the same thing each year,
You think, you figure, you plan—
"Oh, what shall it be?
Between you and me
What gift can I get for that man?"

Something worth while,
That's bound to beguile
The long Winter evenings away.
A Brunswick's the thing,
Great joy it will bring—
Better visit T.-D. to-day.

This ad showed one of their console models which they advised could be purchased on the time-payment plan if desired.

Results of Dealers' Combine Show What Can Be Accomplished to Stimulate General Business Development

the parents of the graduates and at holiday time to the whole family. We also get out a letter to young mothers which has proved very successful. This letter, changed each year, reads:

"Dear Mrs. Blank:—There is nothing in the home of such vital importance to children as good music. There is nothing that binds the family so closely together as the nightly song-fests, or which makes home so much enjoyed by them and all their friends as a Grafonola.

"It is the joy supreme for children of all ages. A mother's lullaby at twilight. What expresses so much love and sentiment? Our lullaby records are as near to mother's as music can be. A little later—the last thing at night—a good-night song for the kiddies—a sweet song that will help them drift off quickly into slumberland. Again, as they grow older, throw back the rug, draw out the Grafonola and dance. Everyone

JUST OUT—POPULAR ITALIAN RECORDS LATEST RELEASES

10-INCH RECORDS AT 75c

1089—'A 'nammurata d' 'o Core
M. Pasqualillo
Margarete' Cav. D. Giannini

1093—Tarantella Sfiziosa R. Ciaramella
'o Piccerillo R. Ciaramella

1083—Ciccuzza P. Mazzone
'a Pacchianella 'e Uttiano
P. Mazzone



New Hits Released the 15th of Each Month

WORD ROLLS AT \$1.25

246—Sotto 'e Cancellè
G. Tetamo—M. Nicolo
252—Separe' C. A. Bixio

249—Ninnolo
E. Tomassini—D. Rulli'
064—Arrivanno 'America. F. Pennino

INSTRUMENTAL ROLLS AT 90c

216—L'eroe
Marcia Sinfonica by E. C. Bevilacqua
248—Simpatia Waltz by B. Simonetti

DISCOUNT TO DEALERS — ASK FOR CATALOGUES

DISTRIBUTED BY

ITALIAN BOOK CO., Music Dept., 145 Mulberry St., NEW YORK, N. Y.

There is Only One "Daily Dozen"

Walter Camp's "Daily Dozen"—Set to Music on Talking Machine Records Are Only Found in "Health Builder" Sets

Your experience is probably similar to hundreds of other talking machine retailers who find their customers insist on Walter Camp's "DAILY DOZEN". *Nothing else will do.*

Can you afford to pass by the profits to be made in supplying this popular demand?

Whether you carry other physical culture sets or not you will find a demand for the original "DAILY DOZEN". This demand is going to be greatly stimulated during 1923 through an extensive advertising campaign. Large ads appearing in the leading publications throughout the country will send customers to your headquarters.

If you do not already carry Health Builder sets, plan to include them in your line for 1923. Write us for full information to-day.



HEALTH BUILDERS, Inc.

DEPARTMENT W1

334 FIFTH AVENUE

NEW YORK, N. Y.

Getting Into a Rut Sounds the Death Knell of Business Prosperity and Progressiveness

When one does the same thing in the same manner time after time there is a distinct lack of progressiveness and that person has entered a rut from which he will find it difficult to extricate himself. As a matter of fact the person or business house which runs along in set grooves descends to mediocrity and if a certain stage of success was reached prior to entering the rut this success will not be lasting, but a process of retrogression takes place and the ultimate end is the only logical one—failure.

The merchant as well as the men whom he employs must strive at all times for originality, freshness and new plans to interest and attract the public. The dealer who plugs along year after year without ever attempting new merchandising plans, without advertising ideas different from others he has put into effect, or without improving his window displays, is sadly in a rut and he is in danger of the calamity mentioned at the end of the first paragraph.

If the merchant is incapable of thinking up new ideas for himself then he should study assiduously a trade paper like *The Talking Machine World* and which bears specifically on his field. In every issue there will be found a wealth of ideas which can be turned into dollars for the merchant who has the vision and energy to capitalize on them. Besides the trade paper there is another source of ideas which might be used by the talking machine dealer and that source is the other merchants in town who face similar problems.

Study not only the methods of your successful competitor, but also those of merchants in related lines of business. Take the furniture business for example. A furniture house has practically the same problems in selling, credit terms, collections, etc., to face that confront the average talking machine dealer. The talking machine dealer might get some important pointers on how to bring up his collections, decrease his repossessions and also increase his sales by getting in touch with the sales, credit and advertising managers of the largest furniture house in his community. Another thing, while it is not always the largest concerns which

use the most successful methods and, therefore, the small houses should not be neglected in this search for information, usually a business that has grown to substantial proportions

Study of Methods of Other Live Dealers for New and Better Ideas Will Result in Improved Policies

has done so because of the simple fact that sound merchandising methods are used.

A good plan would be to co-operate with the sales manager of such a furniture house in

an exchange of certain other kinds of information to the advantage of both. Many people who buy furniture can be persuaded to purchase talking machines and along the same line of reasoning the talking machine purchaser would make a good prospect for the furniture house. An exchange of the names and addresses of these customers would prove valuable to each house. These are only a few suggestions on how a business house can get out of the rut and thereby assure a prosperous career for itself. There are many more and it is up to the dealer to put his thinking cap on and get busy.

Before concluding it might be wise to mention another source of sales ideas—the manufacturers' representatives. These men are often in a position to give the dealer information concerning successful methods tried by other dealers which he would find impossible to obtain in any other way. The traveling man makes personal and intimate contact with many dealers and he is in a position to gain much information which could be put to profitable use by other merchants.

RED RECORD SHOP FORMALLY OPENED

New St. Joseph, Mo., Store One of the Finest in Point of Equipment

ST. JOSEPH, Mo., January 2.—The Red Record Shop, a new talking machine record store, 711 Francis street, this city, was recently formally opened. Lawrence Hayes is owner of the new shop. He has made it one of the most modern stores of its kind in the city. Four private demonstration booths with sound-proof walls are built in the back of the store and the front is fitted out as an attractive waiting and rest room.

The store is finished in gray and walnut and the furniture is of Japanese grass. One of the most attractive features of the place is a group of oil paintings that Mr. Hayes' father, Lee Hayes, has sent him. The new shop will handle Vocalion records.

SOPHIE TUCKER RECORDS POPULAR

Okeh Records Made by Prominent Vaudeville Headliner Well Received—Publicity Campaign Greatly Stimulates Sales

Okeh dealers throughout the country report an active demand for Sophie Tucker records and this popular vaudeville headliner has un-



Sophie Tucker

doubtedly added to her prestige materially through the success of her Okeh records. The General Phonograph Corp. has co-operated with its jobbers and dealers in the introduction of Sophie Tucker records by using timely and effective publicity throughout the country.

The fact that Miss Tucker is well known to practically every vaudeville-goer made the publicity campaign an assured success, and the sale of her records has increased month after month. Miss Tucker, who records for Okeh exclusively, has a voice admirably adapted to recording, and the various hits that she has recorded during 1922 have proven fast sellers in all of the leading trade centers and in the great majority of the small towns where her records are growing in popularity.

"EMPIRE" Packing Cases

Reinforced
Three-Ply
Veneer

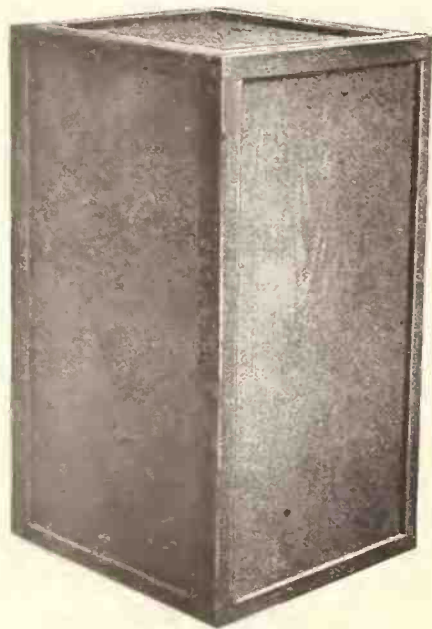

Standard
for
Phonographs
and
Radio Sets

Let us figure on your requirements

EMPIRE MFG. COMPANY, Goldsboro, N. C.



Pathe The World Over



The Radio Business Has Come to Stay

The way to get in it, safely and slowly and to learn it, is to start with a few items that everybody wants. Use the coupon below and we will send you pamphlets showing the Pathe Loud Speaker, Variometer, Coupler and Dials.

DEALERS

Clip Coupon and Mail To Us

RADIO

Please send me pamphlet showing cuts of the Pathe Loud Speaker and other radio parts.

Signed

.....

.....

Make Money Selling Pathe Actuelle Needle-Cut Records

Turn your stock over eighteen times a year and have your money in your cash drawer instead of on the shelf at the end of twelve months.

Others are doing it, why not you? Fill in the coupon below and mail it to us.

We have preserved dealers' profit for him.

You can sell two records easier than one on the 55c each, two for \$1.00 basis (59c each, two for \$1.15 in far west) and cut your overhead in half.

RECORDS.

Please send me 100 of your latest records — 10 selections, 10 of each number, price 30 cents each net to us.

CHECK

....Dance
Vocal
Instrumental
Operatic
German
Italian

Signed

.....

.....

Pathe Phonograph & Radio Corp., 10-34 GRAND AVENUE
 BROOKLYN, N. Y.

“Everybody’s
Runnin’ Wild
 With **“LOOSE FEET”**
 “You can’t go wrong
 With any FEIST song”
 The Two New Hits for The New Year

OVERCOMING ANY AFTER-HOLIDAY BUSINESS DECLINE PEARSALL ADDS TO ITS BRONZE SET

Henry S. Jewett, of the Wholesale Promotion Department of the Aeolian Co., Outlines Practical Plans for Stimulating Business After January First Through Selling and Advertising

After the ringing of happy Christmas chimes why settle into the gloom of a dead march?

Do dealers in musical instruments ever ask themselves whether there's a real reason for accepting the post-holiday sales slump without more of a fight?

The Saturday before Christmas probably finds them at the top figure for 1922 and yet the day's sales on the Saturday before New Year's show a doleful comparison if the after-Christmas dead season is taken for granted.

People's hearts don't stop beating altogether with the passing of the holidays and there's much gift money usually spent after Christmas and New Year's if merchants consider the opportunity.

Luxuries, which include musical instruments, fine furniture and jewelry, can often be sold to people who want to purchase something worthy of the giver with their gift money.

A New York watch salesman told me he sold more watches of high grade during the two weeks following December 25 than he did the two weeks previous.

One of the large department stores had its most successful sale of fine mirrors after Christmas and New Year's, probably because mirrors of quality last for generations—much fine furniture was sold the same week by this store.

In both these cases the dealers advertised and went after the gift money business.

The jeweler might have pulled a blank if he had advertised inferior watches or jewelry at low prices and maybe these days would be poor for featuring pots and pans, but certainly there is a luxury market the last week of December and through January.

Many persons could make their first payment on a piano with gift money if they were made to realize how much more a piano would mean to them than a few perishable items for which they might spend an equal sum.

Phonographs, too, come under the heading of long-lived luxuries and when it comes to records the New Year's business for songs and

dance music for phonographs should be tremendous.

This market is very undeveloped, as is the promotion of piano rolls. I believe a series of human-interest ads run after Christmas and New Year's would do wonders in halting the sales toboggan slide which many people now take for granted.

All the owners of Pianolas and phonographs are in the carnival mood of enjoyment during the holiday period and the possession of these instruments promotes the demand if the dealer only becomes alive to and grasps his opportunity.

Think of all those Winter parties which would be livelier for your January releases. Think of the Winter nights at home your musical merchandise would joyously pass.

Think of the timeliness of your product and make your prospects realize the Winter appeal of music.

Of course, there's no logic in trying to sell ice to Eskimos or cotton stockings to a debutante, but there's every reason to hold the Christmas advantage in sales of music merchandise well into January instead of tying crepe on the cash register the moment you've rung the last Merry Christmas sale.

COMMERCIAL TRAVELERS' GUIDE

A revised edition of the "Commercial Travelers' Guide to Latin America" has just been brought out by the Department of Commerce. The book contains vital information of business etiquette in the Latin-American countries, bringing out the social and business rules observed in these countries and giving to the traveler, who contemplates doing business with our neighbors to the South, a fund of invaluable information.

MORE SPACE FOR GOTHAM SHOPS

The Gotham Shops, Inc., dealers in musical instruments, which recently secured quarters at 17 John street, New York City, have secured additional space at 50 Broadway.

For several years past the Silas E. Pearsall Co., 10 East Thirty-ninth street, New York, Victor wholesaler, has forwarded to its friends in the trade at Christmastime handsome bronze novelties appropriate for use on the desk or in the home. This year's gift consisted of a very attractive paper cutter, accompanied by a card of greetings. These pieces of bronze have become closely identified with the Pearsall organization and the Christmas spirit and many letters of thanks and appreciation have been received by the company from its legion of friends in the industry.

NEW YORK CONCERN INCORPORATES

A charter of incorporation was granted to the American Audioscope Co., of New York City, last week, with a capital of \$300,000. Incorporators are E. F. Ries, A. G. Hansen and L. Zolla. The concern will engage in the manufacture of talking machines.

Main-Springs

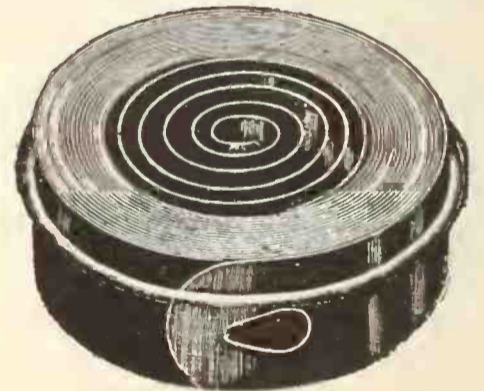

**For any Phonograph Motor
 Best Tempered Steel**

| % Inch | x 10 feet | for all small motors | Each |
|--------|-----------|-----------------------------|------|
| 1 1/2 | x 10 | Pathe, Columbia, Heineman | .30 |
| 1 1/4 | x 10 | Columbia | .40 |
| 1 1/4 | x 11 | Columbia with hooks | .45 |
| 1 1/4 | x 13 | Victor, old style | .50 |
| 1 1/4 | x 15 | Victor, new style | .50 |
| 1 1/4 | x 18 | Victor, new or old style | .70 |
| 1 1/4 | x 12 | Heineman and Pathe | .45 |
| 1 1/4 | x 10 | Saal, Silvertone, Krasberg | .45 |
| 1 1/4 | x 13 | Saal, Silvertone, Brunswick | .50 |
| 1 1/4 | x 16 | Sonora, Brunswick, Saal | .60 |
| 1 3/16 | x 18 | Heineman and Pathe | .75 |
| 1 1/4 | x 25 | Edison Disc | 1.50 |

SAPPHIRES—GENUINE

Pathe, very loud tone, each 15c, 100 lots \$11.00.
 Edison Loud-tone, each 15c; in 100 lots, \$11.50.

TONE-ARMS

The very best, loud and clear, throw-back.....\$4.50
 With large reproducer, very loud, Universal..... 4.00
 With smaller reproducer, but loud and clear..... 2.50

PHONOGRAPH NEEDLES

We can give you best price on Brillantone, Magnedo, Wall-Kans, Tonofone, Nupoint, Gilt Edge, Incas and Veivertons Needles.

ORDER RIGHT FROM THIS AD

Send for price list of other repair parts and motors.
 Terms—F. O. B. St. Louis, Mo. Send enough to cover postage or goods will be shipped by express.

The Val's Accessory House
 1000-1002 Pine St. St. Louis, Mo.



**PHONOGRAPH CASES
 RADIO CASES**

Reinforced 3-ply Veneer

**The Standard Case for Talking
 Machines and Radio Sets**

Let us figure on your requirements

MADE BY
PLYWOOD CORPORATION, Goldsboro, N. C.
 Mills in Va., N. C. and S. C.

THE NEW HALL OF FAME



The New York Press Heralds the Great
SIGRID ONEGIN

Contralto, Metropolitan Opera Co.

A New Exclusive Brunswick Artist

"A voice one is likelier to dream of than to hear."
 "For sheer dazzling brilliance it blazes like the noonday sun."
 "There seems no limit to her technical accomplishment."
 "Seldom is one privileged to hear such splendid and satisfying singing."
 (Pitts Sanborn, N. Y. Globe.)

"A voice destined within a month to sweep some cobwebs from the sainted rafters of the Metropolitan Opera."
 (G. W. Gabriel, N. Y. Sun.)

"Indeed, one of the few great voices of the present day."
 (Irving Will, N. Y. Evening Journal.)

For her first recording Mme. Onegin selected Samson et Dalila (My Heart at Thy Sweet Voice) and Carmen (Gypsy Song), Brunswick Gold Label Record No. 50018—on sale with February records to be released in January. Additional Brunswick recordings of Mme. Onegin will be released each month.

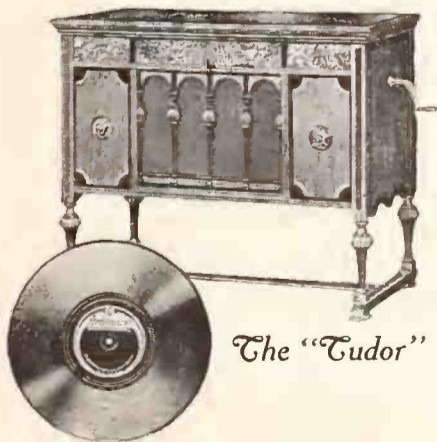

The "Tudor"

Brunswick Records Can Be Played on Any Phonograph

THE BRUNSWICK-BALKE-COLLENDER CO.

Manufacturers—Established 1845

CHICAGO NEW YORK CINCINNATI TORONTO

BRUNSWICK

PHONOGRAPHS AND RECORDS

A-3751—Musical hysterics with a steady flow of hypnotizing rhythm that puts the fidgets in your feet. It's Eddie Elkins' Orchestra playing two gorgeous fox-trots, "Who Cares" and "Blue."

**Columbia Graphophone Co.
NEW YORK**



POWER FROM HARMONIC VIBRATIONS

Montreal Inventor Utilizes Principle of Harmonic Vibrations in Designing Motor

Recognizing the possibilities of the phenomenon of the power of harmonic vibrations, Leslie R. MacDonald, of Montreal, has invented a motor which turns this principle to practical use.

Merely by harnessing a pulley with a web belt attached to a small, rapidly vibrating bar of steel, Mr. MacDonald claims to have devised an efficient source of power—a motor without armature, commutator or brushes and with no rotating parts except for the whirling drive pulley actuated by the vibrating bar. He says that his invention is due to an accidental discovery made while repeating a familiar experiment in physics called "Melde's Experiment." In this, a string running horizontally over a pulley is attached at one end to a small weighted pan, while the other end is fastened to a tuning fork set in motion by an alternating current.

As the fork vibrates, the string, instead of moving back and forth, as one might naturally expect, vibrates up and down with a snakelike whipping motion. Against this vibrating string Mr. MacDonald placed a wooden spool slipped on to a screwdriver. The spool revolved rapidly!

Realizing the possibilities of this phenomenon, the inventor, according to a Popular Science Monthly report, arranged to maintain the vibrations of the fork with an electromagnet—and his new motor was born!

The perfected design includes elements for maintaining free vibrations electrically and a flexible member so tensioned as to allow harmonic waves to be produced in it in such a manner that they perform useful work by turning a pulley.

-DEATH OF MRS. L. S. SHERMAN

Wife of Founder of Sherman, Clay & Co. Passes Away in San Francisco

SAN FRANCISCO, CAL., January 1.—Mrs. Leander S. Sherman, wife of the founder of Sherman, Clay & Co., and mother of Fred Sherman, died recently at the Dante Sanitarium in her seventieth year. The end came rather suddenly, inasmuch as Mrs. Sherman apparently had rallied after a long illness. The deceased had resided in San Francisco for sixty-four years, was a talented pianist, a member of several musical clubs and active in charitable work. The Sherman, Clay & Co. store was closed on Monday, when the funeral was held.

ORANOLA RADIO CORP. CHARTERED

The Oranola Radio Corp., Wilmington, Del., has been granted a charter of incorporation in that State, with a capital of \$1,000,000 to engage in the manufacture of talking machines.

NEW STORE IN ST. PETERSBURG, FLA.

Fourth Store in Philpitt Music Co. Chain Opened Recently in That City

ST. PETERSBURG, FLA., December 30.—S. Ernest Philpitt, head of the Philpitt Music Co., with stores in Jacksonville, Tampa and Miami, recently opened the fourth store of the chain in this city with the complete Philpitt line, including Steinway & Sons, Aeolian Co., Kurtzmann and Francis Bacon pianos, together with Estey organs, band instruments, Victrolas and sheet music. Mr. Philpitt called a meeting of his managers on November 24 to discuss the proposed move and on November 26 the lease on the new store had been signed and preparations made for fitting it out and stocking it.

In the short space of seven years the business of Mr. Philpitt has developed to a point where he is the largest distributor of pianos and Victrolas in the State.

R. O. PERKINS BUYS CURRAY STORE

EAST PALESTINE, O., December 30.—R. O. Perkins, proprietor of the Perkins Music Store, Salem, O., has purchased the Curray Music Store, this city. Mr. Perkins will operate the local establishment as a branch store and will continue to sell pianos, talking machines, musical instruments, etc. The Curray store is the oldest music concern in this section.

MELLOR'S PRACTICAL GIFT TO TRADE

PITTSBURGH, PA., January 5.—With its usual thoughtfulness and consideration the C. C. Mellor Co., of this city, Victor wholesaler, presented its many friends in the trade with a handsome Christmas remembrance, the 1923 gift consisting of a Wahl gold-mounted fountain pen. The name of the recipient is printed in gold on the barrel of the pen and the gift constitutes one of the most practical and handsome Christmas remembrances that the local trade has ever received. T. T. Evans, manager of the Mellor Victor wholesale division, has received many expressions of thanks from the dealers who are delighted with the pen.

R. F. PERRY FINDS BUSINESS GOOD

SALT LAKE CITY, UTAH, January 6.—R. F. Perry, of the phonograph sales department of the Brunswick Co., has just returned from a short trip through the southern Idaho and Wyoming territory and is very optimistic over the increase in business volume and the ever-increasing demand for Brunswick phonographs and records. With the marked increase in the popularity of Brunswick phonographs and records it is quite evident that 1923 will far exceed expectations and be one of the biggest years in the history of the company's activity in the Intermountain territory.



EIGHT FAMOUS VICTOR ARTISTS

In Concert and Entertainment
Personal Appearance of
Eight Popular Victor Favorites on One Program
A live attraction for live dealers and jobbers

Bookings now for season 1923-1924
Sample program and particulars upon request

P. W. SIMON, Manager
1674 Broadway New York City



Famous Ensembles including
Campbell & Burr - Sterling Trio - Peerless Quartet



Produced 95% of All Replies

This highly significant and interesting letter from the Jewel Phonoparts Co. gives actual figures and facts as to the drawing power of advertising in THE TALKING MACHINE WORLD. Many similar letters (all unsolicited) have been received from our advertisers during the past few years.

Please note the reference to foreign distribution and the overwhelming supremacy of The World on a competitive basis.

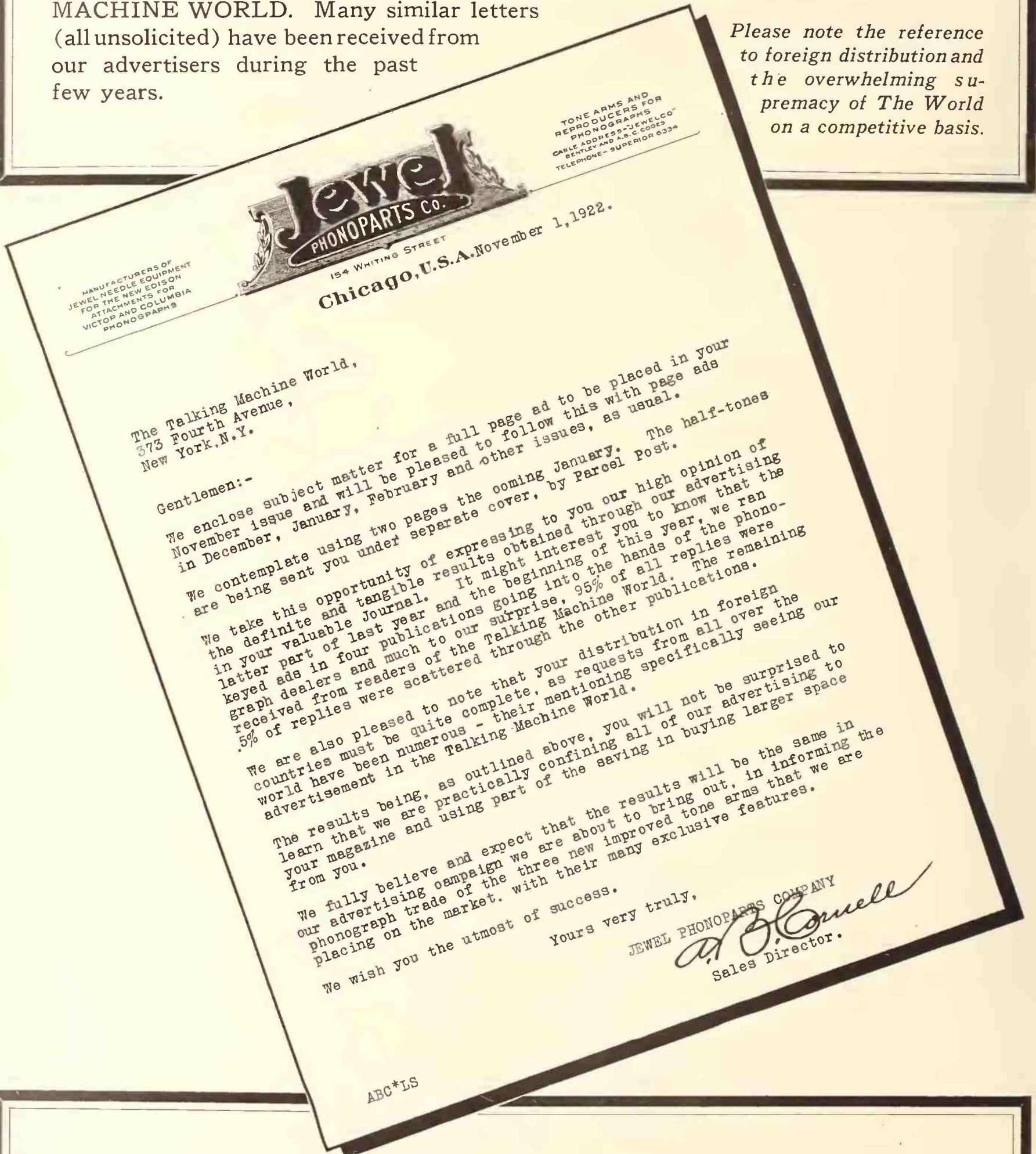

We maintain copy and art departments that will be pleased to submit an advertising plan adapted to your individual proposition. Let us send you copy suggestions.

TALKING MACHINE WORLD, 373 Fourth Ave., New York

Published by Edward Lyman Bill, Inc.

GOOD PROSPECTS FOR 1923 SHOWN IN SURVEY OF TALKING MACHINE TRADE

Feeling of Optimism Based Upon Decided Revival of Trade Prevailing Throughout the Industry—New Year Promises to Be One of Greater Achievement

THERE has been unquestionable proof during the past few months of the fact that the predicted "come-back" of the talking machine business has actually materialized and that both manufacturers and retailers in most sections of the country have been getting their full share of the business volume which in some cases has equaled, if not exceeded, the volume of business done during the peak year of 1919.

It is quite evident that the period of readjustment and stock liquidation in the trade has practically reached an end, and that the business as a whole is in a very healthy and promising condition, with stocks well cleaned out and ready to be built up again from factory shipments. This indicates a demand on the factories that will keep them operating for several months this year which in itself may be taken as an indication of stability.

THE TALKING MACHINE WORLD has taken occasion to make a survey of the general trade for the benefit of its readers, getting opinions from manufacturers, wholesalers and retailers in various sections, and that survey, presented herewith, indicates a feeling of sound optimism that is thoroughly encouraging.

The fact that most of the retailers have entered the new year with small inventories, especially in the matter of machines, is important, for it not only indicates a revival of the demand for talking machines and records, but indicates that what approximates a seller's market will exist for a certain period this year at least.

Good conditions exist in practically every section of the country, although the local situation in certain territories, particularly where the grain growers make up the bulk of the buying population, may suffer a temporary setback.

With the country as a whole prosperous, with a scarcity of skilled labor supplanting the unemployment danger, with money freer and the public apparently more willing to spend it, there appears to be no immediate cause for worry regarding the future of the industry. Certainly those engaged in it, particularly the manufacturers, have full confidence and are backing up that confidence with plans for great activity throughout 1923.

Some of the interesting opinions received by THE WORLD follow and are well worth reading as a guide to the trade situation.

AEOLIAN CO., New York. By O. W. Ray, General Manager of the Vocalion Red Record Division:

"The year 1922 for Vocalion Red records and the Aeolian Co. stands out as a year of increased business, surpassing all past years during its history. We are entering the year 1923 with a staff of twenty-four distributors and an army of dealers to reach our consumers. We are serving the industry with merchandise that has attained a supreme position in its individuality of tone, individuality of color and individuality of profitable returns, and the phonograph merchants have recognized the need to give service on their calls for the Red record. Our factories and our organization are prepared to serve the industry even better than ever before and we back our purpose with a sincere good-will for a bigger, better and more permanent phonograph business."

BRENARD MFG. CO., Iowa City, Ia. By F. W. Kracher:

"Looking forward into the year 1923 we are still optimistic about the opportunities in the phonograph field. Every manufacturer of a high-grade article and every dealer of a quality phonograph has good reason to be optimistic. This optimism is not supported by empty shouting about the good times ahead, but this optimism is built upon the knowledge and under-

standing that the phonograph business is never really good unless we get out and make it so.

"Our experience during the past year has been that there are phonograph prospects everywhere and in considerable number. These are prospects who for a long time have turned away from the phonograph and refused to own such an instrument which produced in their opinion canned music and which could not be classed with a musical instrument at all. The hopeful feature is that this class of people is beginning to realize the necessity of the phonograph in the educational, recreational and social program of every home. Thousands of schools will put phonographs into their list of equipment, hospitals and churches are keenly interested in phonographs as part of their outfitting and real, honest-to-goodness lovers of good music who have looked with prejudice upon the phonograph are placing it into their homes. Here is a large field for the careful, intelligent worker.

"We have good reason to dispel the calamity hue which is discoloring the life of many phonograph manufacturers and phonograph dealers. The time has come when we all must do some real constructive educational work to keep phonograph sales on a productive basis. There will be fewer phonographs 'bought' in 1923 than there were several years ago, but there will be

many more phonographs 'sold' so that any active and wide-awake manufacturer and dealer will not have to take the trip to the poorhouse which so many pessimists have prophesied for the last two years and which we all have sidestepped so long and thus far very successfully.

"Our dealers have been carefully groomed so that they understand that phonographs must be sold, that they will not sell themselves. They have been taught to see prospects all around them, although these prospects will not come tramping to the store.

"With hallucinations dispelled, with determination to get the business by going after it and by finding the numerous prospects still in existence, phonograph business for 1923 will be good. Yes, it means work and plenty of it, and the harder we work the less time we will have to fall into the very bad and dangerous habit of swapping tales of dullness, which exists partly because we accept it instead of getting out and

(Continued on page 30)

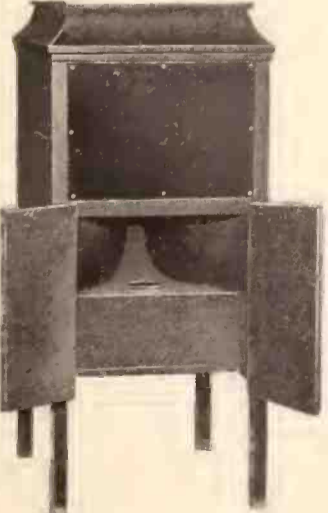

RADIO CABINETS

Especially suitable to completely and conveniently house radio sets. Furnished in Mahogany or Oak; with or without horn, casters or Formica panel. Size 43 inches high, 18 wide, 22 deep. Full details and prices on request.

CURTIS N. ANDREWS

BUFFALO, N. Y.

The
TÉGO BRUSH

CLEANS RECORDS WHILE PLAYING



OVER 10,000 BRUSHES SOLD IN ROCHESTER, N.Y. IN LESS THAN 6 MONTHS

THERE MUST BE A REASON

WRITE FOR PRICES
25¢ BRINGS A SAMPLE

TÉGO BRUSHES FIT ALL MACHINES
WHAT LINE DO YOU HANDLE?

THE STURGIS NOVELTY WORKS

218 CENTRAL BLDG. ~ ROCHESTER, N.Y.

GOOD PROSPECTS FOR 1923 SHOWN IN SURVEY OF TALKING MACHINE TRADE—(Continued from page 29)

literally driving it away by sustained effort." A. BRUNS & SONS, Brooklyn, N. Y. By H. N. Karpen:

"The year just about to close has been considerably better than the preceding year. The apparent hesitancy on the part of the public to invest in musical instruments has largely been overcome and a tone of renewed optimism pervades the country.

"As for the prospects for 1923, it is our belief that the public pulse will be quickened to the fundamental economic soundness of American business. The unemployment situation has been largely overcome and, naturally, steady work at good wages is conducive to renewed prosperity and prosperity is the keynote to good business.

"By the law of economics business can only prosper to the extent that people have money to spend and then spending it naturally gives industry renewed vitality. Taking everything into consideration we feel that 1923 will see the period of depression largely behind us. Judging from the opinions of our large captains of industry we are on the brink of an era of renewed activity in business and naturally a period of prosperity."

BURNS-POLLOCK ELECTRIC MFG. CO., Indiana Harbor, Ind. By A. J. Burns, President:

"Speaking from the point of view of our own product, which is the only product we know much about, I am pleased to state that the amount of business we did during the year 1922 exceeded by 70 per cent the business our company did during the year 1921. We feel that the talking machine business is only in its infancy. We also feel that in order to stimulate the talking machine business and hold the public's attention and admiration for same it will be necessary that there be some radical changes in the present design of talking machines. Every other furnishing which goes into the home has gone through extreme and radical

changes while the talking machine has remained practically at a standstill. This, with the cutting of prices, which has a tendency to destroy the fixed value of the article, has turned the public's mind away from this household necessity, for a necessity it is, as music is a recognized necessity in every home. We attribute our great success in the talking machine field to the fact that we have something different to offer the public and something that adds beauty and charm to the home."

COLUMBIA GRAPHOPHONE MFG. CO., New York. By H. L. Willson, President: "Phonograph and record business will be good in 1923. I make this statement without qualification, based on my observation of industrial conditions in the United States.

"Unemployment is at low ebb, wages remain high, industry generally is on the up-grade, and there is a nation-wide movement toward home building which will create a large potential demand for phonographs and records. Radio has accentuated the value of phonograph music as real entertainment. While six or eight months ago there was some doubt, perhaps, in the minds of prospective purchasers whether to buy a phonograph or a radio outfit, that doubt has been dispelled in our favor. In 1923 there undoubtedly will be less destructive competition in the way of nondescript product and gyp dealing.

"The marked increase in the sales of the Columbia Graphophone Co. in the past two or three months has been most encouraging and, with generally improved conditions and specific conditions applicable to our company's product and policies, leads me to the firm conclusion that 1923 will bring a revival of demand for both phonographs and records, and the practical meaning of the much-used phrase, 'Back to Normalcy' will be realized."

E. F. DROOP & SONS CO., Washington, D. C. By E. H. Droop, Secretary:

"It is our opinion from our wholesale point

IN THE
HANDY
CAN



NYOIL

FOR YOUR
PHONOGRAPH

**Made in Our
Watch Oil
DEPARTMENT**

which for half a century
has made 80% of all the
watch, clock and chronom-
eter oil used in America.

The Best Oil For Any Talking Machine

In refining, Nyoil is given the same care as our famous watch oil receives. All gums and impurities are removed, leaving it

Colorless, Odorless and Stainless.

Housekeepers say they would not be without Nyoil because it is best for phonographs and sewing machines—for polishing furniture and wood-work and is odorless and will not stain. It is free from acid and will not gum, or become rancid. Sportsmen find it best for guns because it prevents rust.

NYOIL is put up in 1-oz., 3-oz. and 8-oz. Bottles and in Quart and Gallon Cans.
For Sale by all Talking Machine Supplies Dealers
WILLIAM F. NYE, New Bedford, Mass., U.S.A.

of view conditions in 1923 will be very much better than during the previous year. Our principal operations are in the South, and this section of the country which was 'shot to pieces' because of the drop in cotton, etc., is recovering.

"I believe the people will have more money to spend, not only for Victrolas, but for pianos and other musical instruments. From general observation I think that the people all over the country are growing into the deeper appreciation of music, as they have found that it is essential in happy home building and maintenance."

EASTERN TALKING MACHINE CO., Boston, Mass. By H. Shoemaker, General Manager:

"Nineteen hundred and twenty-three from present indications and what we can see of the future looks to be the banner year in the talking machine industry. The idea of music in the home is becoming more general than it has ever been and there is more publicity directed at this in the national press than ever before. It is just a question of the ability of the retail merchant to be keen enough to see this and capitalize the work which is being done for him by the press.

"The talking machine market is rapidly becoming stabilized and the financial condition of the companies now in the field is greatly improved, and for this reason the industry is on a firm and stronger basis than it has been for some time in the past."

By E. W. Killgore, Sales Manager:

"Christmas buying on the part of the public demonstrated one thing. Quality and not price was the determining factor. Nationally advertised products were sought after and for this reason Victor dealers experienced the biggest business in their history. Nineteen hundred and twenty-three is a question mark. From all indications it should be a wonderful year for the retailer.

"The announcement of the new model Victrolas was timely and gave a big boost to Christmas buying. The demand could not be supplied and naturally a great deal of buying had to be diverted to 1923. The cumulative effect of the machines sold and now in the home will be great. Each one will be a booster for the machines to come. This, coupled with the national advertising of the Victor Co., should make 1923 a wonderful year."

EMPIRE PHONO PARTS CO., Cleveland, O. By W. J. McNamara, President:

"We are glad to say that 1922 was a very prosperous year for us and the outlook for 1923 looks very bright. The country in general seems to be busy and the mechanic is getting

"THE MODERN WAY TO PLAY THE VICTROLA"
"THE MODERN WAY TO PLAY THE VICTROLA"
"THE MODERN WAY TO PLAY THE VICTROLA"
"MEANS MORE VICTOR RECORD SALES"
"MEANS MORE VICTOR RECORD SALES"
"MEANS MORE VICTOR RECORD SALES"

KNICKERBOCKER
TALKING MACHINE CO., Inc.
138 West 124th Street New York City

Victor Wholesalers

WILL GLADLY SHOW YOU HOW !!

Write for Our Sales Plan

**1923 "THE DAWN OF A NEW ERA IN
THE VICTOR RECORD BUSINESS"**

A Happy New Year to All

Artem Ladega
President

Knickerbocker T. M. Co.

GOOD PROSPECTS FOR 1923 SHOWN IN SURVEY OF TALKING MACHINE TRADE—(Continued from page 30)

a good rate of wages, and we see no reason why 1923 should not be a good year in the talking machine industry."

THOS. A. EDISON, INC., Orange, N. J. By A. H. Curry, Vice-president, Phonograph Division:

Mr. Curry said that there seemed to be no doubt but that the general improvement in Edison business, which has been manifest each month for some months past, predicates an excellent year in 1923, not only for the Edison Co., but for the Edison jobbers and dealers. He estimated that the increase at the factory end would be about 100 per cent over that for 1922; that the jobbers' business would increase about 75 per cent over that for last year, and that the dealers' business would increase on the average 50 per cent over last year.

Liquidation with the Edison retail trade has been practically completed and January 1, 1923, saw the smallest amount of stock on the floor of Edison retailers that has ever been the case. All of this, Mr. Curry feels, will cause a great deal of enthusiasm, in so far as selling efforts during the present year are concerned.

He further feels that the retail dealers will see fit to carry a somewhat larger inventory of instruments than has been the case during the so-called period of depression, owing to more rapid turnover.

With liquidation accomplished and with the floor stocks at a low ebb, the new year will start off on the basis where the dealers will purchase to supply actual needs and the jobbers will do likewise. That is a condition for which the Edison organization has been strenuously working for the last year and which the whole trade has hoped would obtain soon.

Mr. Curry feels that prices will remain stable during the present year as there is nothing now to indicate any likelihood of further reduction owing to the fact that there are no over supplies of raw materials and labor prices do not show a tendency to drop.

A. C. ERISMAN, Boston, Mass.:

"Relative to an expression of opinion as to the development of the talking machine industry in 1922 and the prospects for 1923 we are pleased to submit our views. The year 1922 has been the passing year for many depressed stocks—1922 has been a housecleaning year and the buying public has been offered talking machines of questionable reputation, etc., at ridiculous prices. I now find that those advertising that class of merchandise are finding their sales growing less and less, and I can mention many of the dealers throughout this territory who advise that it does not pay them, at the present time, to advertise the so-called non-descript types of instruments. The same thing applies to the record industry.

"I feel that evolution in the talking machine industry has taken place. We have been in a splendid position to observe this, as one year ago we came out with a line of Strand instruments introducing artistic flat top console models at a price the public could afford to pay.

"In observing the retail business for many, many years, we know the buying public was anxious to have in the home an instrument of beauty as well as tone. Now as the public is offered a combination of both we are advising our dealers that they can look for a wonderfully increased volume of business because in reality they will have two lines of prospects. First, the people that want music in their homes and a high-grade phonograph to furnish this music; second, the class of people that have an eye appeal and will be interested in the instrument from the artistic side of it, giving a much easier selling line of merchandise than they have ever had to offer the public before.

"In observing conditions in the various territories with various dealers and comparing certain dealers in certain cities with others, the same conditions prevail with most of the old-

fashioned dealers that have existed in years gone by. The old-fashioned dealer has been more or less reluctant to take up the new style products and the newer dealers are taking on that product with enthusiasm, and you can see the volume of business going to the new dealers in many localities. It seems pitiable that the old dealers should let their own viewpoint—not the viewpoint of the buying public—rule their establishments.

"We also feel that talking machine dealers, in general, are becoming better merchants, and they realize that there is a certain field in their territory for the sale of instruments and supplies, and they are trying, in every possible way, to take care of their customers' wants by giving them all these various side lines. We have a splendid opportunity of observing this, being independent jobbers—buying lines of merchandise to help the dealer, plus profits to his establishment—and our viewpoint for 1923 is—to those dealers with merchandising instinct—there will be nearly double the talking machine business. In fact, this has been true in the past three months. We have a large number of the more progressive dealers who have doubled their business. For the progressive merchant in 1923 there never has been a better opportunity, in our estimation, than the opportunity that now faces him. The revival of added interest in the talking machine industry is due to the beautiful models that are now offered, which is the one big stimulant, and with many high-grade attractive and useful side lines he has a wider range than ever and a greater opportunity for making sales. Nineteen hundred and twenty-three is going to be a good year for the progressive merchant."

GREATER CITY PHONOGRAPH CO., New York. By Maurice Landay:

"We have enjoyed excellent business this year and feel confident that 1923 will eclipse 1922. Our opinion for increased business in (Continued on page 34)

"As Beautiful as Any High-Grade Phonograph"

—has been the comment about Bestone Wireless Apparatus



The exceptional design, quality materials and scientific accuracy of Bestone Wireless Apparatus has attracted the attention of leading phonograph dealers all over the country.

Bestone Radio Apparatus offers the Phonograph Dealer an unusual profit opportunity—as our line includes Receiving Sets at all popular prices ranging from \$22.50 to \$125.00.

Send for our New Illustrated Catalog and Sales Proposition



BESTONE NO. 701 V.T. DETECTOR AND TWO STAGE AMPLIFIER RECEIVING SET

This Receiving Set has been designed as an instrument of beauty with the capacity of reproducing broadcasting of music, speech and signals with distinct audibility, clarity of tone and without distortion.

Practical tests with this unit have demonstrated unusually long receiving range.

No special or technical knowledge is necessary to operate or obtain the maximum benefits from this high grade Receiving unit.

List Price \$75.00

HENRY HYMAN & CO., Inc.

Manufacturers

Executive Offices:
476 Broadway, New York

Branch:
212 W. Austin Ave., Chicago

VOCA

Phonographs

Distributors of the Vocalion and Vocalion Records

- WOODSIDE VOCALION CO.,
154 High St., Portland, Me.
- LINCOLN BUSINESS BUREAU,
1011 Race St., Philadelphia, Pa.
- CLARK MUSICAL SALES CO.,
324 N. Howard St., Baltimore, Md.
- O. J. DEMOLL & CO.,
12th and G Sts., N. W. Washington, D. C.
- LIND & MARKS CO.,
530 Bates St., Detroit, Mich.
- VOCALION CO. OF CHICAGO,
529 S. Wabash Ave., Chicago, Ill.
- VOCALION CO. OF OHIO,
328 W. Superior St., Cleveland, Ohio.
- LOUISVILLE MUSIC CO.,
529 S. 4th St., Louisville, Ky.
- THE AEOLIAN CO. OF MISSOURI,
1004 Olive St., St. Louis, Mo.
- GUEST PIANO CO.,
Burlington, Iowa.
- D. H. HOLMES CO.,
New Orleans, La.
- STONE PIANO CO.,
Fargo, N. D.
- STONE PIANO CO.,
826 Nicollet Ave., Minneapolis, Minn.

Vocalion Records Are Playable On All Phonographs.



Style 1623

Console Period Vocalions from \$175.
Standard Period Types from \$265.



Style 1624

Jacobean Vocalions

THE sturdy characteristics of the Jacobean Period are obtainable in both *Console* and *Standard Model* Vocalions—individual in style and workmanship. All Period types are equipped with the exclusive Vocalion tone-control—the *Graduola*.

The Aeolian

AEOLIAN HALL



LION

Vocalion Red Records



SELVIN'S ORCHESTRA

Exclusively

VOCALION

THE Vocalion Dance Records of Selvin's Orchestra have gained nation-wide popularity. This top-notch organization plays nightly at New York's Boardwalk Restaurant. They record exclusively for Vocalion Red Records.

Selvin's Latest Recordings

| | | | |
|---|-------|---------|--------|
| Fuzzy-Wuzzy Bird and Open Your Arms, My Alabama Fox-trots | 14472 | 10-inch | \$.75 |
| Don't Bring Me Posies. Fox-trot..... | 14457 | 10-inch | .75 |
| Lovin' Sam and Time Will Tell. Fox-trots..... | 14447 | 10-inch | .75 |
| I Found a Four-Leaf Clover and I'll Build a Stairway to Paradise from <i>The Scandals of 1922</i> . Fox-trots | 14434 | 10-inch | .75 |

Distributors of Vocalion Red Records

- MUSICAL PRODUCTS DIS. CO.,
37 E. 18th St., New York City.
- A. C. ERISMAN CO.,
174 Tremont St., Boston, Mass.
- GIBSON-SNOW CO.,
306 W. Willow St., Syracuse, N. Y.
- SONORA DIST. CO.,
505 Liberty Ave., Pittsburgh, Pa.
- HESSIG-ELLIS DRUG CO.,
Memphis, Tenn.
- STREVELL-PATERSON
HARDWARE CO.,
Salt Lake City, Utah.
- MOORE-BIRD CO.,
Denver, Colo.
- MUNSON-RAYNER CORP.,
643 S. Olive St., Los Angeles, Cal.
- THE MAGNAVOX CO.,
616 Mission St., San Francisco, Cal.

Let us give you complete information for 1923 regarding the Vocalion line of phonographs and Vocalion Red Records.

Company

NEW YORK

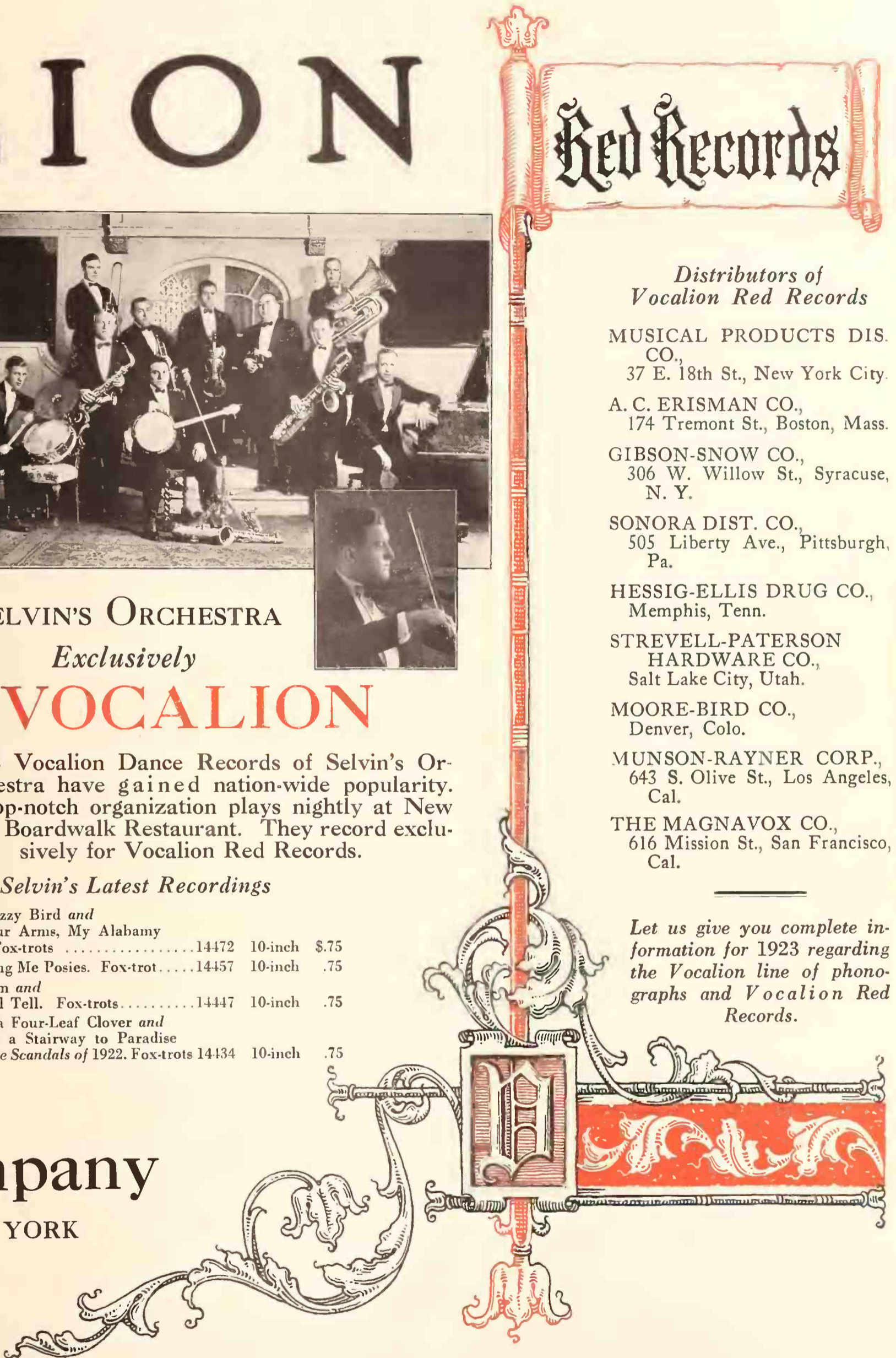



Home Sweet Home, We'll call it Jour-ney's End,

JOURNEYS' END

THE BIG SONG HIT
from
"UP SHE GOES"
THE BIG SHOW HIT

THE NEW "ALICE BLUE GOWN" by the same Writers-

"You can't go wrong
With any FEIST song"



GOOD PROSPECTS FOR 1923 SHOWN IN SURVEY OF TALKING MACHINE TRADE—(Continued from page 31)

1923 is based partly on the fact that the emergency phonograph merchandise has been practically eliminated in this market.

"With the disappearance of this sort of merchandise the field in 1923 will be left entirely to the few nationally known phonographs. We feel assured, therefore, that 1923 will be another successful year for Sonora."

GIBSON-SNOW CO., Syracuse, N. Y. By C. T. Malcomb:

"As phonograph distributors we were greatly surprised at the large volume of business handled during 1922. We thought we were making ample provisions for supplying the demand, but found, after the season had advanced, that we had only scratched the surface. With orders on file for \$50,000 worth of machines we are practically sold out on all models. We fully expect that the most of these orders will stay put and that we will fill them after the first of January. Our dealers are as completely sold out as we are and are accepting orders for Spring delivery. We look forward to 1923 with a good deal of optimism and we anticipate that 1923 will far exceed any year we have ever known in the phonograph business.

"As Sonora distributors we are laying plans for a very strenuous campaign and we hope we will have no difficulty in making our 1923 business even bigger than the 1922 business. We

find that the greater number of our dealers are buying the better class of machines and our sales this year have been on the higher-priced models."

HALL MFG. CO., Chicago. By A. J. Fiddelke, Manager:

"There has been a very noticeable increase from month to month in our line during the year of 1922 and from all indications this increase will continue during the year of 1923.

"The talking machine business in general has about reached normalcy and as business conditions have improved throughout the country during the past twelve months there is every reason to believe that the talking machine line will continue to enjoy prosperity that will surely grow with the start that has been given this line during the past few months. We are now working at top speed in our factory and experiencing difficulty in meeting the requirements of our trade."

KIRKMAN ENGINEERING CO., New York. By T. W. Kirkman, General Manager:

"During the last three months we supplied quite a large quantity of K-E automatic stops to widely separated manufacturers of talking machines. The persistency and regularity of their orders convince us this represents a permanent improvement rather than mere Christmas business. The manufacturers have

paid comparatively promptly and we believe they are in improved financial condition.

"Business appears to be well distributed and not spotty and we are quite hopeful for the future, and products, conditions and trade volume in 1923 will be a great improvement over 1922."

MODERNOLA CO., Johnstown, Pa. By E. E. Holmann, Manager of Sales:

"The year 1922 with all its trials and troubles is past us. It was a year which we believe will not soon be forgotten. The labor situation with its strikes and the unprecedented price cutting were both factors which made the outlook for the year very gloomy indeed. Add to this the fact that early in 1921 our factory was destroyed by fire and that due to this fact we re-entered the trade in 1922 almost the same as a new concern, we are glad indeed to say that notwithstanding these handicaps the business of 1922 was very satisfactory. The last four months of the year were encouraging and even surpassed our expectations.

"Judging solely from the reports of our sales force and from letters received from our dealer representations, the year 1923 will see the phonograph trade back to normal. The advance orders we already have indicate to us that confidence has been restored and that the dealers look to a very prosperous 1923."

MUTUAL PHONO PARTS MFG. CO., New York. By A. P. Frangipane, Secretary:

"A review of the business we have done in 1922 is undoubtedly very similar to the reports from other concerns in the phonograph industry. For the first eight months there was but slight improvement over the previous year, but in the latter months a high-water mark for monthly sales was reached. In fact, each of the last three months of 1922 surpassed the best previous sales record.

"Although a barometer of the phonograph industry will show that the last few months of any year are wont to showing an increase, thus giving rise to a feeling of optimism for the ensuing year, nevertheless we believe that 1923 will show a decided improvement over the past several years. This impression is based upon the fact that we are receiving many inquiries from manufacturers who specify their requirements for the early part of 1923 and request that we quote accordingly. Without exception they all state that they expect to do a big business in 1923. In closing let us hope that 1923 will fulfill the prophecies of good

(Continued on page 35)

VELVET COVERED TURNTABLES

ADD TO THE QUALITY OF MACHINES



A.W.B.

Boulevard
VELVETS

THE BEST TALKING MACHINES ARE EQUIPPED WITH

A. W. B. BOULEVARD VELVETS

GRAND PRIZE—GOLD MEDAL, ST. LOUIS EXHIBITION

WRITE FOR SAMPLES AND PRICES

A. WIMPFHEIMER & BRO., Inc.
450-460 Fourth Avenue, New York

ESTABLISHED 1845

COTTON FLOCKS

.. FOR ..

Record Manufacturing

THE PECKHAM MFG. CO., 238 South Street
NEWARK, N. J.

HONEST QUAKER MAIN SPRINGS

REG. U.S. PAT. OFF.



COPYRIGHT MCMXXIII E. T. M. Co.

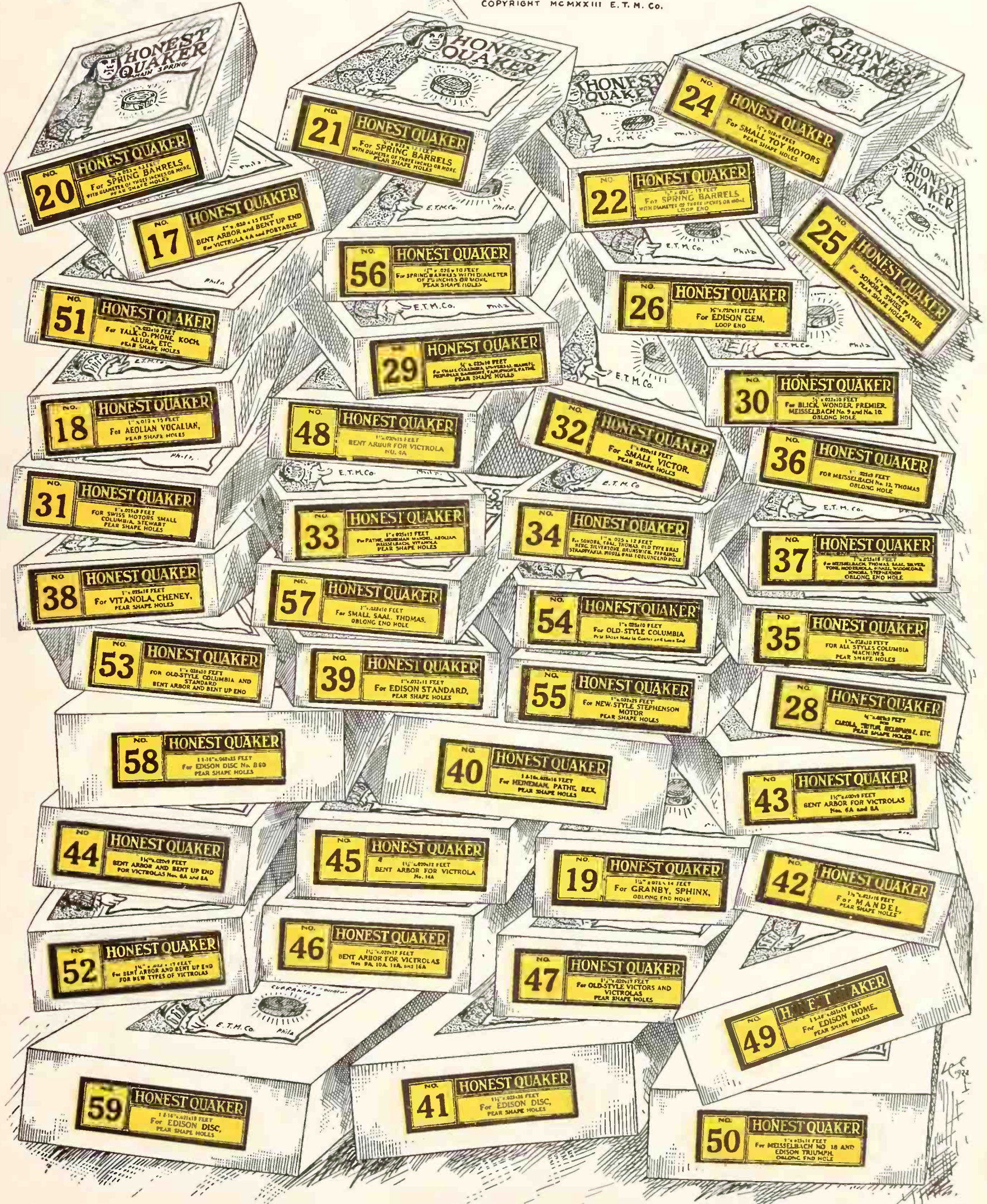

Makers:—

EVERYBODY'S TALKING MACHINE CO., Inc.

Philadelphia, U. S. A.

Nora Bayes slips another quarter into the meter and cooks up the honest-to-goodness, best sing-song of "Lovin' Sam" (The Sheik of Alabam') that has yet been. For dessert she serves "Daddy's Goin' Huntin' Tonight." Both on the same platter. A-3757.

**Columbia Graphophone Co.
NEW YORK**



GOOD PROSPECTS FOR 1923 SHOWN IN SURVEY OF TALKING MACHINE TRADE—(Continued from page 34)

fortune emanating from various sources in the phonograph field."

NEW YORK ALBUM AND CARD CO., INC.,

New York. By Max Wellinger, President:
"Although the early part of 1922 certainly appeared very gloomy from a business standpoint I was at all times confident of the future and enthusiastic in preaching that the winding up of the year would be favorable. I am now glad to see that this little prophecy of mine has proven correct even to a greater extent than I had anticipated. Prices on raw materials have advanced recently to a certain degree and in all probability the market will not go lower during the year. The merchants, however, have been placing orders in larger quantities, which means that the manufacturer will be busy right along. I expect 1923 to be a prosperous year in every way."

SEABURG MFG. CO., Jamestown, N. Y. By E. J. Seaburg, President:

"We have had a very good Fall and holiday trade and business conditions for the Spring, judging from inquiries received, and business conditions in general, are very good; in fact, we are starting out the New Year with a substantial amount of orders for immediate and Spring delivery."

GENERAL PHONOGRAPH CORP., New York. By W. C. Fuhri, General Sales Manager, Record Division.

"Our company is closing its most successful year as manufacturer of Okeh and Odeon records and we have reason for optimism concerning the future of this branch of our business especially. During the past six months many important dealers have added the Okeh and Odeon line, and their purchases indicate their enthusiasm. Reports coming from all parts of the country indicate that dealers have enjoyed a very large sale of phonographs and records during the past Christmas season and it is very evident that the interest of the public in

phonograph music is growing from year to year. Higher priced instruments are going into homes of the people of the United States who feel that the phonograph is the most versatile of all entertainers, and the public is willing to pay for a high-class instrument which will serve not only as an entertainer, but as an ornament.

"There is a tendency on the part of the public toward console design phonographs, and many fine examples are being offered by manufacturers of fine furniture who have an established reputation. The designs of some of these period type instruments are especially attractive and the word 'nondescript' is no longer suitable when applied to the quality product of high-class manufacturers, who have entered the field during the past year.

"The day of the 'nondescript phonograph,' in my judgment, is past, and the time has arrived when the independent quality instrument is appreciated by the public, which realizes that, like the automobile, a phonograph may be assembled of standard units which insure equal service and satisfaction, when compared with products manufactured by some of the older companies in the business.

"It is generally known that, without exception, automobile manufacturers buy a large part of their equipment from companies which specialize particularly in electrical apparatus, etc., and there is no reason why manufacturers of fine furniture cannot, with success, build high-class phonographs of equal merit with any on the market, and, in many cases, these instruments can be offered the public profitably by the dealer, at substantially less, because heavy overhead expenses do not exist.

"The public is beginning to realize this, and I am certain the future of these independent instruments is extremely good. This is indicated by the forward contracts we have for phonograph motors and equipment, running into the year 1923.

"Further evidence is given by the fact that some of the foremost dealers in the United States, who cannot afford to handle anything but meritorious products, are offering independent models to their customers with assurances of satisfaction.

"1923 will be a big year for the phonograph trade, and, of course, the more phonographs sold the more records we will sell, if our product continues to receive the approval of the public, as is evidenced by the year which we have just closed."

WALL-KANE NEEDLE MFG. CO., INC., Brooklyn, N. Y. By N. Cohen, President:

"The writer merely wishes to state that he is very optimistic about the coming year and believes that it will be a very successful one. We have found, during the past year, that the Wall-Kanes are so well established that it was absolutely unnecessary to have any representation for them on the road. The mail orders have been so heavy that we have been rushed to capacity to fill them and we believe that this is due to the advertising campaigns so successfully carried on since this needle was introduced."

LIND & MARKS CO., Detroit, Mich. By S. E. Lind, President.

"We are pleased to be able to express our satisfaction with the results of the year 1922, looking at it from many angles. Over one hundred and fifty new dealers have been added to our books during the past year, and the repeat business obtained from them has been most gratifying.

"We feel that prospects for 1923 are very good indeed, and we expect our 1923 business to show an enormous increase, even over our 1922 showing, and we are planning an advertising campaign for the coming year on our Wolverine line.

"We base this upon the fact that practically
(Continued on page 36)

A FEW JOBBING TERRITORIES STILL OPEN

WALL-KANE NEEDLES

Each needle guaranteed to play ten records.

CONCERT NEEDLES

Steel needles in tones of extra loud, loud, medium and soft.

JAZZ NEEDLES

The special extra loud needle. The only one of its kind in the world.

Profit-Producing Jobbing Proposition

WALL-KANE NEEDLE MFG. CO., 3922 14th Avenue, BROOKLYN, N. Y.

GOOD PROSPECTS FOR 1923 SHOWN IN SURVEY OF TALKING MACHINE TRADE—(Continued from page 35)

without exception all of our dealers are planning intensive selling campaigns on both Vocalion and Wolverine lines of merchandise for the coming year. Almost without exception the dealers on our lists are now operating on sound business principles and are laying their plans carefully, and with considerable foresight, and we cannot see anything but an era of advancing prosperity for the talking machine and record industry during 1923."

THE TALKING MACHINE CO., Philadelphia, Pa. By George A. Tatem, Sales Manager.

"Along with all other Victor jobbers, we have enjoyed a very satisfactory year. The two weeks preceding Christmas, especially, have vindicated the belief we consistently held for months that the holiday demand for Victor products would be even greater than preceding years.

"While the usual shortage was quite evident, less difficulty was experienced in adjusting stocks because the demand was not so much centered on one or two types as in previous years. This had a twofold advantage, in that it enabled both jobber and dealer to fill practically all orders with few exceptions and at the same time clean the slate for the new year.

"Looking ahead to the coming year we have but to review our past eighteen years' experience in handling Victor products exclusively to find a firm foundation for our confidence of even greater opportunities in the year immediately ahead and many years to come. Every indication points to an unusually prosperous year for 1923. It is well to remember that our recovery from the depression following the war has been gradual, but steady. There is room for much encouragement in the very fact that the buying public shops more deliberately than in previous years. This means, if it means anything, that Victor business will grow even more rapidly than in previous years, because the public is going to be more discriminating in

its choice of musical instruments. As jobbers of Victor products exclusively, we are already laying our plans for greater activities in the full confidence that the close of 1923 will justify our faith in the future of this business.

"As far as we have been able to ascertain, practically all of our dealers hold the same optimistic view of the possibilities that lie just ahead."

LOUISVILLE MUSIC CO., Louisville, Ky. By Ben L. Loventhal, President.

"The fact that we have taken a ten-year lease on a new store in the high-rent district, which we believe to be the best located retail store in the city, shows our faith for the coming years in the talking machine business.

"Business for the year 1922, in volume, has been very satisfactory and from all appearances we have made money. However, this cannot be determined until stock-taking time. Both our retail and wholesale business shows a strong tendency to grow. We believe this is due to the fact that tobacco conditions are good and that the tobacco raiser in this part of the country is being properly financed on a co-operative basis. Cotton conditions are also much improved. With these conditions in view we are mapping out a larger program for 1923, as we believe conditions warrant it."

UDELL WORKS, Indianapolis, Ind. By Tom Griffith, Sales Manager.

"As far as the Udell Works are concerned, we are coming into the new year with more real or sure business than we have had since 1919. It is not special contract business either, and is from folks who discount their bills. The new year looks mighty good to us, and, in fact, the tremendous home-building program that has been going on in this country is going to make the talking machine business good. This, in our judgment, is inevitable. We have had in the last four months a splendid business and there is not any question in our minds but what

the new year is going to be a good one for us.

"The only word of caution that we can suggest is that manufacturers and jobbers, and, in fact, the whole fabric, must be careful and not start this price pyramiding again, because if they do there will result but one thing, and that is a strike on the part of the buyers and the whole house of cards will fall down on us again. There is, of course, danger of this in a rising market, but I believe that the business men of this country have learned their lesson."

UNIT CONSTRUCTION CO., Philadelphia, Pa. By H. H. Beach, Vice-president:

"All information received to date bearing upon trade conditions throughout the country gives indication of the talking machine business having made decided strides during the past three to four months and of having attained a more solid commercial footing. This must necessarily have a most beneficial effect upon the 1923 results.

"Better selling organizations and better general business getting facilities are in evidence; these, plus a determination toward still greater improvements, seem to be the order of the day.

"Normalcy has no decisive meaning to-day. I do not see wherein we can be guided by any particular previous records or achievements. The future should be treated as a distinctively new business era and every effort should be put forth to establish new standards much higher than those by which we have been guided in the past.

"We have in our engineering department more plans for contemplated store changes than ever before at this season. This in itself is good evidence of an awakening on the part of the trade to the need of putting talking machines and kindred products before the public in a higher class manner. This in itself will tell the story better than almost anything else, as it has long been recognized that proper presentation is probably the chief essential in the merchandising of phonographs and talking machines. We are exceedingly optimistic and are very certain that our optimism is based on a good solid foundation."

VICTOR TALKING MACHINE CO., Camden, N. J. By Ralph L. Freeman, Director of Distribution:

"Of course, the most important development affecting our industry in 1922 has been the general improvement in fundamental conditions. In the trade itself the liquidation of inventories of goods that could not stand the strain of a competitive market, the correction of past mistakes in buying, the balancing of stocks and the elimination of irresponsible manufacturers mark mile posts on the road of progress.

"As to this year our feeling is that general conditions will be a full third better than in 1922, that the talking machine business will be larger in at least that degree and that standard trade-marked products will enjoy the preference they merit. Our production schedules up to May are based on this expectation.

"We believe there already is a noticeable change in demand favoring records of selections of a higher class than those that had such a considerable vogue in the recent past and that this promises to be a feature of this year's business."

WASMUTH-GOODRICH CO., Peru, Ind. By E. M. Wasmuth, President

"Nineteen twenty-two has been a big year in the talking machine world, not perhaps so large in the volume of business done but certainly a very consequential year as it affected the industry.

"Old stocks and obsolete patterns with which the trade was deluged during the early part of the year have been, to a large extent, liquidated, the demand has increased and the business has been stabilized to an extent that approaches the condition that existed prior to the depression, beginning in 1920.

"Everything promises at least a normal demand for phonographs in 1923. There should,

The 1923 Season Is Before Us Has 1922 Met Your Expectations?

Why Not Try Something Different?

THE MODERNOLA The Special Feature Machine

As Good as the Best
Better Than Many

Our Portable, THE MODERNOLETTE, has been acknowledged by the trade to be the biggest value on the market.

Retails at \$35.00

Some unoccupied territory
still open. Write Department H.

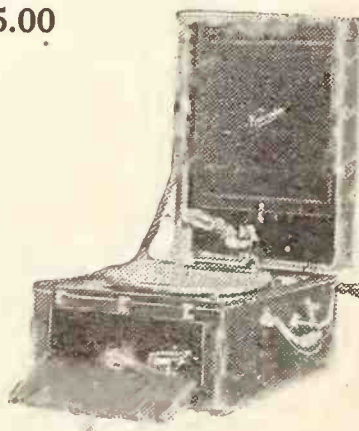

MODERNOLA CO., Johnstown, Pa.

The Modernola Sales Co., Inc.

929 Broadway, New York, N. Y.

GOOD PROSPECTS FOR 1923 SHOWN IN SURVEY — (Continued from page 36)

we think, be a warning given to manufacturers and dealers to conduct their business in a conservative way and not to be stampeded by abnormal seasonal demand.

"Nineteen twenty-three should be one of the best years that the industry has ever experienced and undoubtedly will be if safe and sane business methods are observed."

LAKESIDE SUPPLY CO., Chicago. By G. C. Fricke, President

"Our experience this year in the talking machine industry shows that practically all of the dealers in the country allowed their stocks to run down, not taking any chances of any further decline in wholesale prices. When the holiday season was approaching and the dealers found it necessary to replace their merchandise, it absolutely swamped the factories and no one was able to take care of the demands. We ourselves are behind and others in the industry cannot accept orders for shipment for from three to four months.

"It appears as though there is going to be a continuous, healthy business in the phonograph industry, irrespective of the fact that radio has taken such a strong hold. We contend that the radio will never replace the phonograph, as the reproduction from a record is far superior to the music that comes in on the radio.

"There remains but a very small amount of surplus material in phonographs in the country and the era of low prices has passed. The phonograph business is rapidly coming back into its own and we anticipate a prosperous year."

MICKEL BROS. CO., Omaha, Neb. By H. B. Sixsmith, Sales Manager

"The Christmas Victor business throughout the State greatly exceeded our expectations. Of course, there are probably still a half dozen towns that are laboring under strike conditions, but this influence was not so great as to affect the general returns.

"The peak of most every line of business was reached in 1920 and I have it from most of our larger dealers and also from some of the larger mercantile establishments that the 1922 business had reached the 1920 peak before December 1, and that December gave them the greatest business in their history.

"Iowa is an agricultural State. The smaller towns that are forced to rely on the farming communities for their business did not fare as well as the larger towns that have a fair proportion of their population on fixed salaries. The farmer is one of the most complaining mortals on the face of the earth, and in view of the fact that he has been in the dumps for so long it takes the other extreme of business conditions to increase his optimism to any noticeable extent. It is true that his products are bringing him greater returns than last year and this fact has caused him to loosen the purse-strings a little more.

"The general belief is that the business during 1923 will show a marked increase over the previous year. The momentum gathered from the remaining days of 1922 will last sufficiently into 1923 to stiffen the backbone of the merchant."

CHENEY TALKING MACHINE CO., Chicago. By Alfred C. Harper, President

"We look forward to the year 1923 with a great deal of optimism as we believe that the phonograph business will be very satisfactory. General business conditions are sound. Labor is very well employed at present, which means greatly increased purchasing power among all of the laboring classes, and the marked advance in food products over a year ago is rapidly restoring the purchasing power of the farming communities. We believe this increased purchasing power means greater prosperity in the entire phonograph industry of 1923.

"The business of the Cheney Talking Machine Co. has been very satisfactory during 1922, as we had a very marked increase over the previous year. During 1922 we opened up

a number of new accounts among the finest dealers in the country and their business has been very gratifying. The enormous demand that developed for the Cheney during the Fall months was such that it became necessary for us to refuse to take on any new accounts. We are rapidly increasing our production in our Grand Rapids plants which will make it possible for us to take on the very desirable accounts which we had to refuse during the past season."

SHERMAN, CLAY & CO., San Francisco, Cal.
By A. M. Bird, Manager, Wholesale Victor Department

"In my opinion the most important development during the year 1922 was the action on the part of the Victor Co. adding to its catalog of instruments the horizontal models. Apparently they have opened an entirely new field for the sale of Victrolas. Observation would indicate that the buying public is divided into two classes, those preferring upright models and those who have waited for the announcement of the horizontal models. The development of this latter class should amount to considerable proportions during the next few years. This does not mean that the upright models are to become obsolete—the contrary is the fact.

"The outlook for 1923, in my opinion, is most promising in this section, based on the following:

"1. The holiday buying is reported to be the largest in the history of this State.

"2. Increased buying has been general throughout the country since July 15.

"3. The crops of this State and this country have increased materially in value, enhancing the purchasing power.

"4. The public in general and business men individually are talking and thinking prosperity. This is the first essential in my opinion to a forward movement, as opinion guides judgment and judgment guides investments and causes a general loosening of the purse-strings."

NEWMAN'S MUSIC SHOP, Jersey City, N. J.

By A. B. Newman

"Early in 1922 when conditions were very bad we made this decision. People would buy phonographs. The styles would be chiefly period and the public would slowly but surely demand quality merchandise presented in a clean manner. We also decided that the day of the nondescript was about to pass.

"We made arrangements to give the public this merchandise of quality, then we altered our store so that we could present it properly. New booths and an entire new store front were installed at considerable expense. After it was all done we wondered for a time if we made a wise decision, for business did not seem to respond as anticipated to the new fixtures and improvements.

"Constant plugging gradually brought results on machine business. We made it a point to promote record business also by means of window displays which in the past were impossible, owing to our lack of display space. We shortened terms on machines and were careful in accepting accounts. After accepting accounts we followed collections religiously.

"Suddenly we received excellent results. Quality merchandise and period models were in demand far greater than the supply. Record business increased 40 per cent over last year, (1921). Sale after sale we have traced to our new store front. We know of one instance where a customer passed several phonograph stores to purchase from us simply because our store front attracted her and when in the market she remembered the instrument seen in our window.

"Not only did the public demand the machines of type and quality anticipated, but record purchases were made from a quality standpoint also. Although dance records are the most popular, we find the demand not only for a certain selection, but necessary that it be recorded properly and by a well-known orches-

(Continued on page 40)

ADD-A-TONE

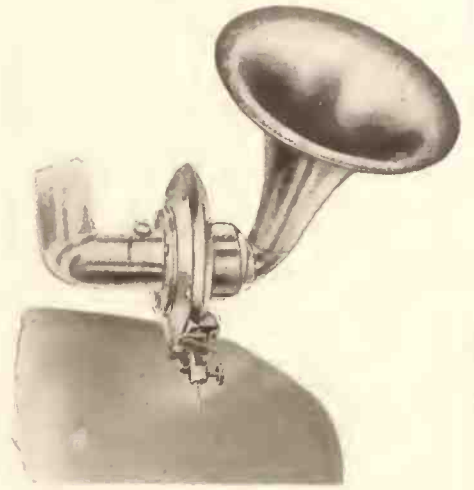

The Supreme Tone Amplifier

Attractive in appearance and possessing a clarity of sound and volume obtainable in no other sound box

Incomparable for Dancing

Unique Products

are superior in QUALITY and clear in tone. The novel spring suspension insures against "blasts" and produces a perfect harmonious rendition.

The Unique Reproducer

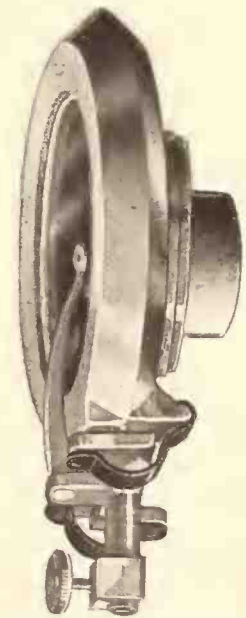

UNIQUE REPRODUCTION CO.,
INCORPORATED

32 Union Square, New York City

DEALERS:

Write us for prices and samples

New EDISON Consoles To Fit Every Purse

William and Mary Console

THE antique period style of this William and Mary console model is appropriate for use in the finest home. The design is authoritative in every detail, yet this console blends harmoniously with the furnishings of any room. The New Edison in this beautiful case is an unmatched value at the price of \$325.



Chippendale Console

The present vogue for the style of Chippendale will undoubtedly create a wide demand for this charming console design. And the rich, clear notes of the New Edison, thus encased, will sell music-lovers who recognize tone perfection.

The Chippendale Console is priced at \$295.



London Console

HERE is the lowest-priced console of the Edison group. Although its retail cost is only \$135, yet it embodies the musical perfection made possible by Mr. Edison's \$3,000,000 research, sharing the same quality as the more expensive models. The London Console will be welcomed by many who desire a high-grade phonograph in console design, at moderate price.



Baby Console

At \$175 the New Edison in Baby Console design is a model that can be featured with assured sales success. Its conservative, artistic lines combine suitably with the furnishings of any room; its musical quality is typical of the Edison standard.



THOMAS A. EDISON, Inc.

ORANGE, NEW JERSEY

GOOD PROSPECTS FOR 1923 SHOWN IN SURVEY OF TALKING MACHINE TRADE—(Continued from page 37)

tra. Back of this we see a keener appreciation of good music in the future. The featuring of 'Humoresque,' 'Song of India,' 'Kashmiri Song' and other selections by movie theatres has not only created business but is educating the people to appreciate better music. We feel that much can be accomplished if talking machine dealers organize and work with the theatres in this respect.

"We anticipate good business during 1923. We shall sell quality merchandise only, present it in attractive surroundings, refrain from advertising terms and accept only reasonable terms. We believe period machines will be the most popular, but our sales will average about 60-40. We also expect good record business during the coming year. They say 'Only dead fish float with the tide,' but we believe the phonograph dealer who takes advantage of the tide by rowing with it instead of floating will end 1923 with a satisfactory business."

OGDEN SECTIONAL CABINET CO., Lynchburg, Va. By J. B. Ogden, President

"Everything indicates that 1923 is one more wonderful opportunity for every live, up-to-date working phonograph dealer. Our conclusions are based upon business increasing steadily from October 15 and rapidly increasing business after November 15 to date. Orders mailed to us on December 21, 22 and 23 for service equipment clearly indicate the attitude of the dealer at this time.

"These orders, which came to us voluntarily by mail—(largely as a result of World advertising)—from all sections of this country, Central and South America, as well as the 'Islands,' would indicate that this business improvement is very general and our plant is working overtime during Christmas week to keep up.

"Business in hand and bright prospects for the future justify extensions to improve service. We will be greatly disappointed if 1923 does not prove a 'banner' year for the phonograph trade as well as all others."

SHERBURNE MANUFACTURING CO., Detroit. By E. Sherburne, President

"We believe that 1923 will be the best year that we have had for a long time, as looking at 1922 in retrospect we can see a steadily increasing prosperity; this was reflected not only in our business, but in every line, and this has laid a very good foundation for the coming year.

"We do not believe, however, that we are going to be able to snatch prosperity out of the air—we will have to work for it—as we find that people are more exacting in their demands and they insist on quality, and although they are willing to pay for what they get, they insist on getting what they paid for, which, we believe, is the most healthy and promising sign for business success that can be asked for.

"The four-flushers born of the war conditions are gradually being weeded out, and we now have things on a solid give-and-take basis which

makes us greet the coming year with every feeling of confidence."

STREVELL-PATERSON HARDWARE CO., Salt Lake City, Utah. By A. L. Kirk, Manager, Sonora Department

"The largest part of the territory covered by us is made up of farming communities in which the farmers have made little progress during the year. While harvesting good crops the prices they received for their fruit, potatoes being so very low, they were unable to reduce their indebtedness to the banks and merchants to any great extent, and they had very little surplus to spend for phonographs. We were fortunate enough to realize that this condition would prevail very early in the year and devoted our selling efforts to the larger cities and towns which have a larger payroll and also a larger population.

"We are very glad to be able to advise that our efforts resulted in a sales total up to December 20 three times greater than for 1921. The new period models helped, of course, to bring a large number of people back in the market for phonographs, and had we been able to secure our entire order placed with the Sonora factory our sales total would have been very much greater.

"We do not look for any great improvement in this territory under present conditions until the next Fall crop is harvested, and while quite a few new industrial plants are contemplated in this district, which will mean the spending of millions of dollars, the direct benefit of these operations will not affect us for at least another year."

PHILIP WERLEIN, LTD., New Orleans, La.

"The backbone of the South is the farmer. When he is prosperous, most everyone else is, down our way—and the brisk business that wound up 1922 in this section indicates that reported good crops and good prices of our biggest staples, cotton and sugar cane, were no myth.

"We know that the farmer is on his feet again in most localities. He has liquidated most of his old indebtedness and has something left over for the future. This healthy condition is supplemented by the fact that our other dependencies such as lumber, oil, sulphur, salt, etc., are all holding their own. Even the rice farmers are in better shape than they were in 1921, and the end of 1923 should see them happy and prosperous once again.

"Other encouraging signs are the steady increase of our population, hundreds of new homes going up, and improvements such as new public buildings, paving and good roads in most all of our communities. Last year, in a certain section of Mississippi, a hundred miles above New Orleans, truck farming brought three million dollars among farmers who had become miserably poor raising cotton. Just fifty miles out of New Orleans there is a community that will have a four million dollar strawberry crop

this Spring. Is it any wonder, then, that we are anything but optimistic?

"Vigorous effort among the unsold list of talking machine prospects should bring us a substantial return on our efforts, and we are bending all of our energies in that direction."

E. E. FORBES & SONS PIANO CO., Birmingham, Ala. By E. E. Forbes, President

"We are very much encouraged regarding the business situation as the farmers in this section are recovering from the losses suffered through poor crops for the past two years and with good crops and good prices this Fall have been able to catch up on their debts. Our manufacturing industries are running at full capacity and everyone who wants to work can secure a job. Wages have been raised twice recently in the iron industry.

"In our business we have had the best trade this Fall we have had since the Fall of 1920, and the past Christmas season was a most prosperous one not only for the music merchant, but also for those in other lines of business.

"We are now jobbers of the Paramount phonographs and records and we are going after business good and strong. We are featuring the Brunswick phonographs and records in our retail business. We have recently secured the services of two good salesmen, H. L. West and J. R. Whitaker, and we are looking forward to great results from them. We feel quite sure our phonograph business is going to be very much greater this year than it has been for the past two years. We became kind of discouraged for a time, quit buying phonographs and tried to clean up what we had in stock. But we are going after business good and strong now and expect to get great results."

FINE CLAPP-EASTHAM EXHIBIT

Large Display Cabinet and Other Products Attract Attention at New York Radio Show

The exhibit of the Clapp-Eastham Co., of Cambridge, Mass., at the New York Radio Show was a center of interest and, what is more, developed a considerable amount of business. The exhibit was advantageously located near the main entrance and consisted principally of the large display cabinet which was illustrated and described in full detail in last month's issue of *The Talking Machine World*. This same cabinet was shown in the Chicago and Boston radio shows. Two new developments of the company, consisting of a new Vernier knob and dial and a new Vernier rheostat, were exhibited in New York for the first time. W. W. Webber, of the home office of the company, was in charge of the exhibit and it was expected that E. Clifford Estey, general sales manager of the company, would be present during a part of the week. There were a large number of visitors present and the company's booth attracted many.

Retails
25c

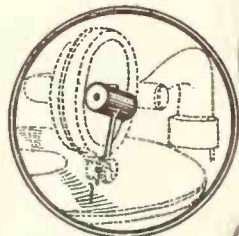

INSTANTLY
ATTACHED

The
Melo-Tone
TRADE
MARK
ATTACHMENT

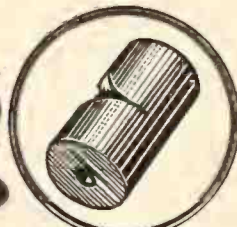

INSTANTLY
REMOVED

Retails
25c

REDUCES SURFACE NOISE IMPARTS TO ANY PHONOGRAPH A SOFT, RICH, MELLOW TONE
AIDS IN THE SALE OF RECORDS AIDS IN THE SALE OF MACHINES

Customers are amazed at the results obtained with the MELO-TONE
50 MELO-TONES IN ATTRACTIVE CARTON, \$7.50

If your jobber cannot supply you, order direct. Jobbers who are not already handling this fast-selling specialty, communicate at once with

L. D. HEATER, National Distributor, 357 Ankeny St., Portland, Ore.

Costs so little—
Accomplishes so much

Equip Your Record
Rooms with Melo-Tones

MAIN SPRINGS—PARTS FOR ALL MOTORS—MACHINES

COMPONENT PARTS FOR COLUMBIA MOTORS

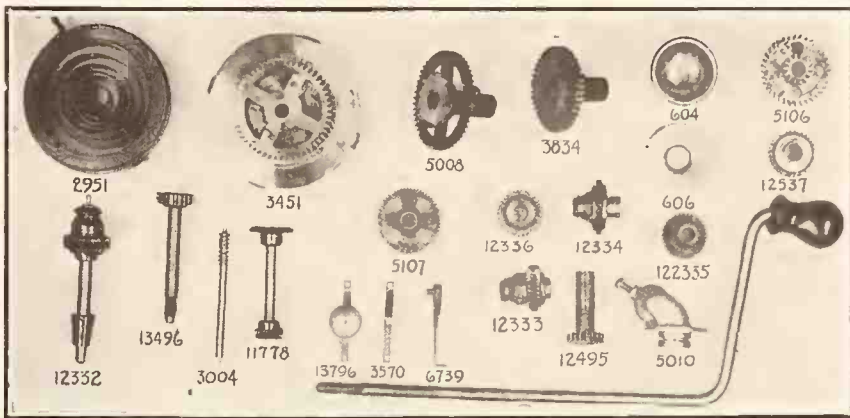

COLUMBIA

| No. | Description | Price each |
|-------|--|---------------|
| 2951 | Columbia main springs..... | \$0.33 |
| 3451 | Columbia spring barrel bead..Complete | 0.75 |
| 5008 | Spring, barrel winding gear, old style.. | 0.75 |
| 3834 | Spring barrel winding gear, new style.. | 0.75 |
| 604 | Needle cups | Per 100 2.00 |
| 606 | Needle cup covers..... | Per 100 1.00 |
| 5106 | First intermediate gears..... | Complete 0.40 |
| 5107 | Second intermediate gears..... | Complete 0.40 |
| 12537 | Worm gear for single-spring motor..... | 0.30 |
| 12336 | Bevel pinion single-spring motor..... | 0.35 |
| 12333 | Bevel pinion, regular style..... | 0.75 |
| 12334 | Bevel pinion, latest style..... | 0.75 |
| 12235 | Bevel pinion for old-style double spring.. | 0.50 |
| 12332 | Bevel pinion disk shaft..... | Complete 1.00 |
| 13496 | Male winding pinion..... | 0.30 |
| 12496 | Female winding pinion..... | 0.30 |
| 3004 | Governor shaft | Complete 0.50 |
| 11778 | Driving shaft | Complete 0.08 |
| 13796 | Governor balls..... | Per 100 1.50 |
| 3570 | Governor springs, each 0.02..... | Per 100 0.35 |
| 6739 | Stylus bar | Complete 0.35 |
| 5010 | Universal attachment | 0.35 |
| 13228 | Winding crank, 3 sizes..... | Each 0.35 |
| | Columbia Governor Screws..... | Per 100 1.00 |
| | Columbia Barrel Screws, No. 2621..... | Per 100 1.00 |
| | Columbia Sound Box Thumb Screws | Per 100 1.50 |

MEISSELBACH

| No. | Description | Price each |
|--------|---|---------------|
| P9764 | Main springs for motors 16, 17, 19.. | \$0.50 |
| P9765 | Main springs for motor No. 12..... | 0.30 |
| CP532 | Governor | Complete 1.50 |
| P1504 | Governor shaft, new style..... | 0.50 |
| P1505 | Governor shaft, old style..... | 0.50 |
| AP533 | Governor ball | Complete 0.10 |
| CP644 | Turntable shaft Nos. 16, 17, 19..... | 1.25 |
| CP645 | Turntable shaft for No. 12..... | 1.50 |
| AP697 | Spring barrel cup for Nos. 16, 17, 19 | 0.50 |
| AP698 | Spring barrel cup for No. 12..... | 0.60 |
| CP1113 | Spring barrel shaft and gear..... | 0.10 |
| P1529 | Brake lever, bottom plate..... | 0.10 |
| P604 | Brake lever, top plate..... | 0.10 |
| AP528 | Winding shaft for Nos. 16, 17, 19.. | 0.50 |
| AP529 | Winding shaft, straight cut Nos. 16, 17, 19 | 0.35 |
| AP530 | Winding shaft, spiral cut, for 10; 12 | 0.35 |
| AP531 | Winding shaft, straight cut, for 10; 12 | 0.35 |
| AP591 | Brake lever..... | 0.35 |
| CP536 | Intermediate gear for Nos. 16, 17, 19 | 0.90 |
| M | Winding cranks, 3 sizes..... | 0.75 |
| 140 | Speed indicator | 0.45 |

HEINEMAN

| No. | Description | Price each |
|---------|--------------------------------------|-----------------|
| CP5226 | Governor | Complete \$1.50 |
| CP9799 | Turntable shaft | Complete 1.50 |
| AP9924 | Governor balls, 33; 77; 44..... | 0.10 |
| AP9925 | Governor balls for No. 36..... | 0.10 |
| P5004 | Governor pinion for No. 0..... | 0.25 |
| P5003 | Governor shaft | 0.50 |
| CP9629 | Speed indicator | 0.45 |
| P9764 | Main spring for No. 33 or 77..... | 0.33 |
| P9765 | Main spring for No. 36..... | 0.25 |
| P9766 | Main spring for No. 44..... | 0.60 |
| AP9778 | Spring barrel cup for No. 33 or 77.. | 0.50 |
| AP9779 | Spring barrel cup for No. 36..... | 0.50 |
| AP9780 | Spring barrel cup, for No. 44..... | 0.75 |
| P9762 | Winding shaft for motor No. 33..... | 0.60 |
| P9966 | Winding shaft for motor No. 36..... | 0.40 |
| 5304 | Winding shaft for No. 44 or 77..... | 0.75 |
| 5007 | Escutcheon | Complete 0.15 |
| AP9409 | Turntable brake | 0.15 |
| AP10072 | Winding crank, 3 sizes..... | 0.75 |

VICTOR

| No. | Description | Price each |
|------|---|--------------|
| 5012 | Winding gear | \$0.60 |
| 5013 | Turntable gear, straight cut, small teeth.. | 0.35 |
| 5014 | Turntable gear, large teeth straight cut.. | 0.35 |
| 5015 | Turntable gear, small teeth, spiral cut.. | 0.35 |
| 5016 | Turntable gear, big teeth, spiral cut..... | 0.35 |
| 5021 | Rubber back for exhibition box..... | 0.25 |
| 5017 | Rubber back for No. 2 sound box..... | 0.25 |
| 5018 | Governor collar | 0.15 |
| 5019 | Spring barrel shaft | 0.60 |
| 5020 | Stylus bar for No. 2 box..... | 0.35 |
| 5022 | Stylus bar for exhibition box..... | 0.35 |
| 5011 | Attachment for vertical cut record..... | 0.25 |
| | Governor springs, for Victor..... | Per 100 1.00 |
| | Governor screws, for Victor..... | Per 100 1.00 |
| | Governor balls, new style, for Victor..... | 0.08 |
| | Needle arm screws for exh. box, per 100.. | 1.50 |
| | Needle arm screws for No. 2 box, per 100 | 1.50 |

PARTS—HARDWARE

| No. | Description | Price each |
|------|---|--------------|
| 5000 | Crown gear for Blick motor..... | \$0.25 |
| 5001 | Crown gear for Melophone motor..... | 0.25 |
| 5002 | Crown gear for Heineman No. 0..... | 0.25 |
| 5003 | Tone-arm goose neck for independent arm | 0.25 |
| 5004 | Governor pinion for imported motor..... | 0.25 |
| 5005 | Tone-arm base for independent arm..... | 0.25 |
| | Automatic nickel-plated lid supports..... | 0.45 |
| | Automatic gold-plated lid supports..... | 0.22 |
| | Piano hinges, nickel-plated, 1 1/2 in. long | 2.00 |
| | Highly nickel-plated needle cups..... | Per 100 1.00 |
| | Covers for cups..... | Per 100 7.00 |
| | Highly gold-plated cups..... | Per 100 5.00 |
| | Needle cup covers, gold-plated..... | Per 100 1.50 |
| | Turntable felts, 10-in., round or square.. | 0.15 |
| | Turntable felts, 12-in., round or square.. | 0.18 |
| | Motor bottom gear for Triton motor..... | 0.20 |

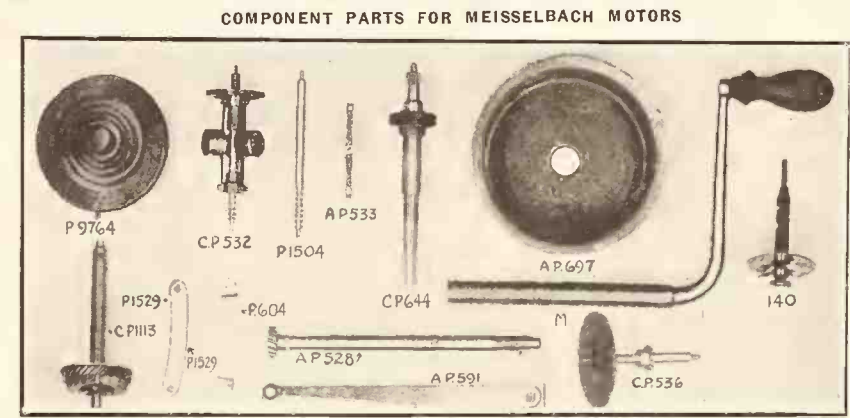

COMPONENT PARTS FOR MEISSELBACH MOTORS

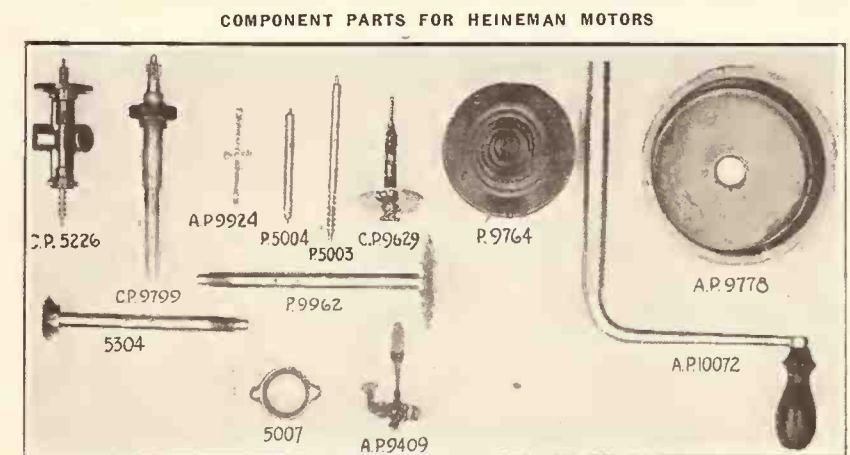

COMPONENT PARTS FOR HEINEMAN MOTORS

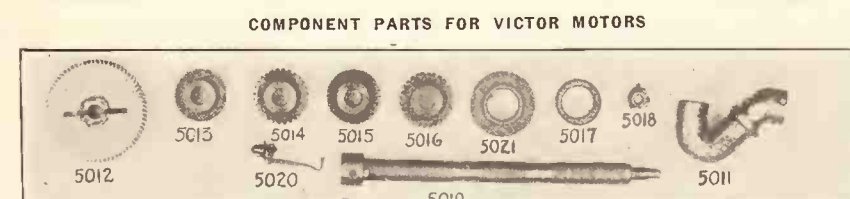

COMPONENT PARTS FOR VICTOR MOTORS

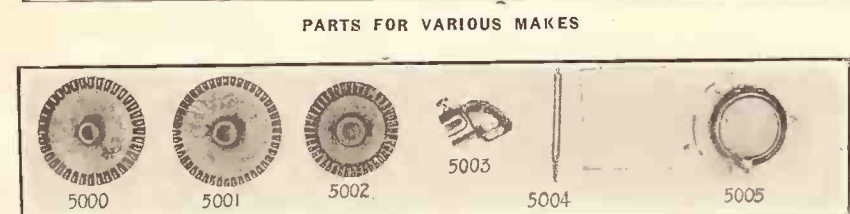

PARTS FOR VARIOUS MAKES

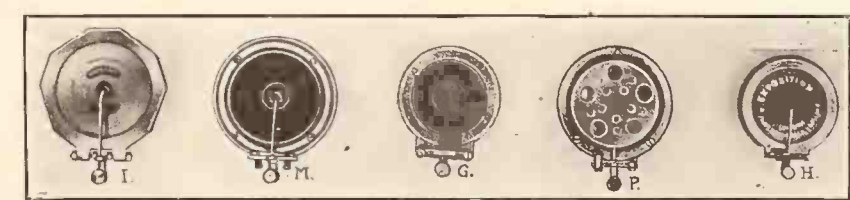
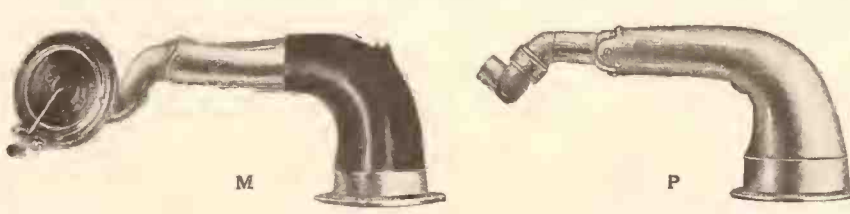

Monthly Price List Main Springs of Highest Quality

| Description | Price each |
|---|------------|
| 2 in. x 0.22 x 16 ft., Meisselbach No. 18..... | \$1.25 |
| 2 in. x 0.25 x 16 ft., for Edison | 1.25 |
| 1 1/4 in. x 0.22 x 17 ft., reg. for Victor..... | 0.60 |
| 1 3/4 in. x 0.22 x 17 ft., Victor, bent arbor..... | 0.60 |
| 1 3-16 in. x 0.25 x 16 ft., Heineman No. 44..... | 0.60 |
| 1 1/2 in. for Edison Disc..... | 1.25 |
| 1 in. x 0.25 x 12 ft., Heineman No. 33 and 77.. | 0.33 |
| 1 in. x 0.25 x 16 ft., oblong hole, for Meisselbach, Sonora and Krasberg..... | 0.50 |
| 1 in. x 0.28 x 10 ft., for Columbia | 0.33 |
| 1 in. x 0.22 x 10 ft., for Columbia | 0.30 |
| 1 in. x 0.20 x 13 ft., for Victor | 0.33 |
| 1 in. x 0.20 x 13 ft., for Victor, bent arbor..... | 0.33 |
| 7/8 in. x 0.23 x 10 ft., for Blick motor..... | 0.30 |
| 3/4 in. x 0.25 x 10 ft., oval hole..... | 0.28 |
| 3/4 in. x 0.22 x 8 ft., German motor | 0.25 |
| 5/8 in. x 0.22 x 8 ft., for Swiss motor | 0.22 |
| 5/8 in. x 0.25 x 11 ft., for Edison | 0.22 |
| 1 in. x 0.25 x 19 ft., for Brunswick | 0.60 |
| 1 in. x 0.22 x 9 ft., for Meisselbach No. 12..... | 0.30 |

MICA DIAPHRAGMS

| Description | Price each |
|---|------------|
| 1 23-32 in. Victor Ex. Box, 1st grade..... | \$0.15 |
| 1 1/2 in., new Victor No. 2, very best..... | 0.18 |
| 1 31-32 in., for Sonora | 0.20 |
| 2 1-16 in., for Meisselbach box..... | 0.22 |
| 2 3/4 in., for Pathé new style..... | 0.35 |
| 2 3-16 in., for Columbia No. 6..... | 0.25 |
| 2 9-16 in., for Pathé or Brunswick..... | 0.45 |

SAPPHIRES

| Description | Price each |
|---|------------|
| Pathe, very best, loud tone, genuine..... | \$0.12 |
| Pathe, soft tone, ivory setting..... | 0.18 |
| Pathe, soft tone, steel setting..... | 0.10 |
| Edison, very best, medium tone..... | 0.18 |
| Edison, very best, loud tone..... | 0.15 |
| Edison, genuine diamond..... | 1.25 |

STEEL NEEDLES

| Description | Price each |
|--------------------------------------|-----------------|
| Brilliantone, all tones..... | Per 1000 \$0.45 |
| Blue Steel Reflexo, per package..... | 0.07 1/2 |
| Wall Kane Needles, per package..... | 0.06 |

ATTACHMENTS

| Description | Price each |
|--|------------|
| in Gold or Nickel-Plated | |
| Kent, for Victor arm..... | \$0.25 |
| Kent, for Edison with C box..... | 2.50 |
| Kent, without box for Edison, nickel or gold.. | 1.60 |
| Universal old style, for Victor tone-arm..... | 1.15 |
| For Columbia, plays Vertical records..... | 0.25 |

MOTORS

| Description | Price each |
|---|------------|
| Distributors for Heineman and Meisselbach Motors. Best Prices. Immediate Deliveries. | |
| Meisselbach No. 17, 3-spring..... | \$15.00 |
| Krasberg No. 33, 4-spring..... | 15.00 |
| No. 36, complete with 12-in. turntable..... | 7.50 |
| No. 33, complete with 12-in. turntable..... | 8.50 |
| Imported single-springs, 10-in. turntable..... | 2.25 |

STONE ARMS

| Description | Price each |
|---|------------|
| No. K, with sound box | \$1.25 |
| No. P, nickel-plated without sound box..... | 2.75 |
| No. P, gold-plated | 4.50 |
| No. M, tone arm, Meisselbach sound box..... | 4.75 |
| No. M, gold-plated Meisselbach sound box..... | 7.50 |

SOUND BOXES

| Description | Price each |
|---|------------|
| No. B-1 Bliss Sound Box, fit Victor..... | \$1.25 |
| No. B Balance, fit Victor..... | 0.75 |
| No. F Favorite, fit Victor..... | 1.75 |
| No. I Nickel-plated, loud and clear..... | 3.00 |
| No. I Gold-plated, loud and clear, for Victor.. | 4.50 |
| No. M Nickel-plated, mellow tone, for Victor.. | 1.75 |
| No. M Gold-plated, mellow tone, for Victor.. | 2.25 |
| No. G Nickel or gold-plated, fit Victor..... | 1.00 |
| No. P Gloria patent, extra loud..... | 3.00 |
| No. P Gloria, gold-plated..... | 4.00 |
| No. H Imported, nickel-plated..... | 1.25 |

ILSLEY LUBRICANT

| Description | Price each |
|-----------------|------------|
| 5-lb. Can | \$1.60 |
| 1-lb. Can | 0.40 |
| 4-oz. Can | 0.15 |

DELIVERY ENVELOPES

| Description | Price each |
|---|------------|
| 40-lb. Brown Kraft 10-in., per 1,000..... | \$7.50 |
| 40-lb. Brown Kraft 12-in., per 1,000..... | 9.50 |

GENUINE

HOHNER HARMONICAS

| Description | Price each |
|---|------------|
| 1896 Marine Band, any key, per doz..... | \$4.50 |
| 1896 Full Concert, per doz..... | 10.00 |
| 214 1/2 Vestpocket Harp, per doz..... | 3.60 |
| 151 Marine Band Tremolo, per doz..... | 8.00 |
| 606 Echo (double-sided), per doz..... | 10.00 |
| 34B The Old Standby, per doz..... | 4.00 |
| 132 Hohner Band, per doz..... | 4.25 |
| Complete revolving standing with 3 doz. Harmonicas, 32 inches high, mahogany..... | 26.50 |

FAVORITE MFG. CO., 105 E. 12th St., New York City

Telephone 1666 Stuyvesant

ASK TO HEAR IT



THREE O'CLOCK in THE MORNING

Tempo di Valse Lente



It's three o'clock in the morn - ing,

"You can't go wrong with any 'Feist' song"



The WORLD FAMOUS CHIMES WALTZ THAT IS MOVING A MILLION FEET

SEASONAL GREETINGS ON RECORDS

Vogue of Sending Christmas Greetings on Small Records Quite General This Year—Party Invitations on Records a Newer Stunt

This year more than ever before various concerns have resorted to small talking machine records attached to cards on which there is a brief message, explaining the object of the record, to give their Christmas greetings an individual and unique touch. Among the several concerns in the music business which have adopted this method of extending best wishes of the season is included the Premier Grand Piano Corp., of New York, which sent out small records bearing the seasonal message. The records were attached to cards appropriately decorated with holly and in addition a small paper of needles was supplied, so that the only thing that was lacking was the talking machine.

Another example of the use of these small individual records was put in effect by Irving S. Morange, a theatrical man, of New York. He sent out his invitations to a Christmas party in the form of a talking machine record, carrying his own voice, in a parody of a popular vaudeville team. The cost was not any higher than many engraved invitations sent out.

"It is forty-five years since Thomas A. Edison designed the first phonograph, but this is the first time a personal invitation to a Christmas party has been sent out in this way." This anyway is the opinion of C. R. Johnstone, vice-president and general manager of the Bell Recording Corp., of 9 East Forty-seventh street, New York, who made the records for Mr. Morange.

Mr. Morange conceived the idea a few years ago, but none of the larger record companies did work on a small scale for the individual, so he had to wait until Mr. Johnstone became connected with a company to produce records

for individual singers, musicians or just plain citizens. Then Mr. Morange popped the idea at this old hand at the business.

His Christmas invitation record is entitled "Christmas Egg Nog," a carol sung to the lilting melody made famous by Mr. Gallagher and Mr. Shean. The chimes start off the invitation. Then Mr. Morange and one of his friends, in a duet, explain what will happen at the party, and the record-invitation ends with a medley of tunes of the pre-Volstead days: "How Dry I Am" and "When I Die Don't Bury Me at All."

About seventy-five of the records were mailed by Mr. Morange. They are seven inches in diameter and cost about 25 cents apiece. They were made in just the same way that all the records of famous singers and orchestras are made by the large companies, and Mr. Morange thinks that he has shown the way to a new field of phonograph business—the individual record or message which may be either a party invitation, a message from sales manager to his field "forces" or a selling or advertising argument by any commercial concern.

"As to getting the record heard, there won't be any trouble in encountering the man who has no phonograph," said Mr. Johnstone. "If the man who receives one of these records has no machine he will break the speed limit in getting to the talking machine store or to the house of the nearest friend who has one, because he will want to know what words the disc carries to him."

BROWNING BROS. CO. TO ENLARGE

OGDEN, UTAH, January 4.—Glen Thomas, manager of the Brunswick department of the Browning Bros. Co., this city, reports many sales on Brunswick consoles. The business has increased to such an extent that arrangements are to be made in the near future to enlarge.

AN EFFECTIVE "HOMESICK" WINDOW

Stone Piano Co. Arranges Beautiful Window Exploiting the Vocalion Red Record of That Number—Enthusiastic Regarding Future

MINNEAPOLIS, MINN., January 6.—The Stone Piano Co., distributor of Vocalion Red records of this city, recently had an original and beautiful window display in connection with "Home-

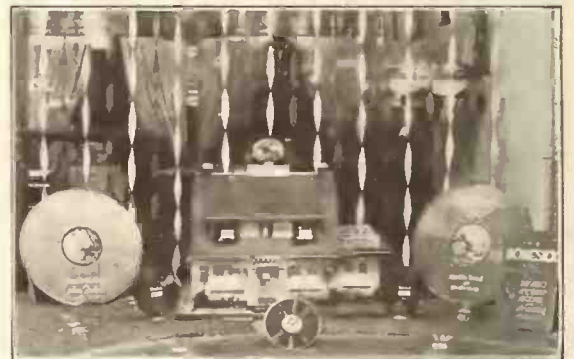

Stone Piano Co.'s Attractive Window sick Week," when the song "Homesick" in record and other forms was strongly exploited. The display, which is reproduced herewith, proved very effective in bringing Vocalion records of "Homesick" to the attention of the public, and resulted in a big demand for that number. V. T. Stevens, manager of the Vocalion record department of the Stone Piano Co., is very enthusiastic over the future of that line in his territory and is co-operating with the dealers in every way.

WILL DIAGNOSE "TALKER" ILLS

WASHINGTON, D. C., January 3.—Harry C. Grove, Inc., 1210 G street, Columbia dealer of this city, has just announced the installation of a "phonograph hospital" where the ills of talking machines will be diagnosed and cured.



New Model "E"

The General Phonograph Mfg. Co. Model "E" TABLE PHONOGRAPH

The Greatest Value on the Market

IMMEDIATE DELIVERIES IN ANY QUANTITY

Plays All Makes of Records

Superior Tone Quality

Write for our Proposition

The General Phonograph Mfg. Co.

ELYRIA, OHIO

SOME SALES STIMULATORS

There are many towns and cities surrounded by farming districts, and it is safe to say that the rural dwellers living some distance from the nearest city do a great deal of their buying from the large mail order houses, although this method of making purchases is not indulged in as much as before the advent of the automobile. Talking machines and records are bought from descriptions in the catalogs of mail order houses very often and whenever a sale of this character is made the nearest local dealer has lost out. How to go after this trade most effectively is the problem. One dealer placed a registration book at the entrance of his store and over this was a large placard requesting out-of-town visitors to register their names and addresses so record supplements and other literature could be sent to them from time to time. In this way a number of names of people who lived in the rural districts were secured and as a result a nice business was developed with out-of-town residents. Dealers located in a similar manner might find it worth while to emulate this plan. There is no doubt but that mail order houses are making many sales which would go to local dealers if proper steps were taken to secure this business.

Of what avail is it to constantly spend money for new customers if old patrons are permitted through one reason or another to discontinue doing business and take their trade elsewhere? Would it not be much better to spend some of this money in retaining the patronage of old friends? The Cable Company, of Chicago, faced with this problem, has checked up, through its books, customers who have stopped buying records and a plan has been put in effect whereby every inactive customer receives a personal call from a member of the staff. The plan has resulted in bringing back to the fold a number of accounts which have been inactive for a considerable length of time. Of course, many customers are lost through moving, death, etc., but the fact remains that often a slight misunderstanding will bring about a breach which results in loss of trade. These things can best be straightened out through a personal visit and if that is impossible, a diplomatically worded letter.

A number of talking machine dealers have increased their sales of records during the last year by amplifying their service. The plan consists of sending a repair man to all owners of machines for the ostensible purpose of making a free inspection of the instrument and making any necessary minor repairs. Usually this repair man possesses some sales ability and he carries with him several of the latest records which he plays. While at a customer's home he strives to impress the patron with the service which his firm is extending and at the same time skillfully draws attention to the merits of the records which he plays. Of course, where possible, he plays music which will most probably fit in with the musical taste of the customer. Sales of records are often made and the service actually makes a profit for the dealer who goes about it in an intelligent manner.

A talking machine dealer in a small town in the Middle West has considerably enlarged his accessory sales by sending out personal letters to each of his customers, drawing attention to the increased enjoyment to be derived from the use of a certain accessory, such as a record brush, albums, etc. Only one accessory at a time is featured in these letters.

MONTHLY TRADE SURVEY POPULAR

Work of the Government in Securing Current Trade Information Much Appreciated

WASHINGTON, D. C., January 5.—The monthly survey of current business inaugurated in July, 1921, by the Secretary of Commerce has proved to be very popular among the business men of the country, according to the annual report of the Director of the Census, just made public. The survey contains summaries of the production, stocks, sales and prices of a number of industries, covering over 700 items, and offers a comparison for the progress of the various industries each month with that of preceding months.

Most of the information from which the survey is compiled is secured from trade associations, but in some cases these figures have been supplemented by the collection of statistics direct from individual firms not reporting to the associations. While the survey at the beginning covered only a few commodities the number has been greatly increased; only seven

trade associations contributed statistics for the first issue, but the number has been increased until at present more than 700 associations are reporting regularly, and compilations of data are also made from over thirty Government departments and twenty-seven technical periodicals.

MARRYING JUDGE USES VICTROLA

PEORIA, ILL., January 3.—Music and that happy hour when the matrimonial knot is tied go hand in hand, in the opinion of Judge Owens, of this city, and to prove that he really believes music an indispensable part of this important ceremony he has installed a Victrola in his office. When a wedding party comes to have the nuptial knot tied the judge first plays appropriate music and then proceeds with the "operation."

The Chalifoux Music Dealer Co., Inc., Birmingham, Ala., is now located in more spacious quarters at 108 North Nineteenth street.

HARPONOLA



The Phonograph with the Golden Voice

We can show you how to make money in the phonograph business —

Jobbers and dealers who want a COMPLETE machine of super grade will find the Harponola Phonograph a trade-winner.

Assemblers who want a CABINET on which repeat business can be built should get our very interesting prices on cabinets.

We will make you an attractive proposition on any quantity and on any basis.

Backed by the experience and management of Brandts and Mersman brothers, known the country over for their success as furniture and cabinet builders.

THE HARPONOLA COMPANY

CELINA, OHIO

Edmund Brandts, President

IMPROVED VICTROLAS ANNOUNCED

Victor Co. in Letter to Trade Announces Important Change in Models 80 and 100

In a letter to the trade under date of December 20 the Victor Talking Machine Co. announces several improvements in the general design of Victrolas Nos. 80 and 100, the chief feature of which will be the enlargement of the tone chamber. The letter announcing the changes reads:

"As a result of our constant endeavors to improve our product, we are pleased to announce that the next factory shipment of Victrola instruments Nos. 80 and 100 will be of an improved design.

"The new No. 80 has a larger cabinet, being 40½ inches high, 20 inches wide and 22 inches deep, which permits of a larger amplifying chamber and consequently better tone quality. This model is also equipped with record shelves.

"The new Victrola No. 80 will be made in only one mahogany finish, which we expect will

meet the demand for both red mahogany and English brown mahogany. We expect to begin shipments of this type in the early part of January.

"The outside measurements of the improved Victrola No. 100 will not be perceptibly different from the present style, but the doors of the amplifying chamber are larger and the front posts will be carved in a smaller but similar design to that used on the Victrola No. 111. This new design of the No. 100 represents even greater value than ever before. Shipments will probably start late in January or early in February."

P. S. HEILBUT IN NEW POST

P. S. Heilbut, formerly with O'Loughlin, Brunswick dealer of Salt Lake City, has been appointed credit manager of the Bates Stores Co., of Provo, Utah. Mr. Heilbut will also manage the Brunswick-Edison department for the Bates Stores Co. and his wide experience will undoubtedly prove beneficial.

VALUE OF THE ARTISTIC WINDOW

Dealer Cannot Make a Better Investment Than to Utilize His Window Space to Advantage—Some Suggestions of Timely Interest

The value of a properly displayed window as a means of stimulating interest in the dealer's store has been the subject of frequent mention in *The World*, largely because this publication is a firm believer in the idea that the properly displayed and effectively lighted window is as valuable a medium for corraling trade as advertising in the daily papers.

Frequent changing of display and simplicity of design are necessary to success, but there is no question that the proper lighting of display windows is of prime importance if the dealer wishes to secure a rounding out of results. A manufacturer of lighting equipment recently worked out a schedule of colors to be used where the merchandise in the window was uniform in hue. He holds that the single color light is likely to distort the colors of the merchandise even though it attracts attention, and says that color contrasts and pleasing effects can be produced by two or more colors which harmonize with and emphasize the display matter. The following indicates the results obtained when color lights are mixed: Red plus yellow equals scarlet; orange, in increasing proportions of yellow. Red plus green equals scarlet, orange, yellow, yellow-green; in increasing proportions of green. Red plus blue equals red-purple, purple, blue-purple; in increasing proportions of blue. Yellow plus green equals yellow-green; in increasing proportions of green. Yellow plus blue equals yellowish-white, bluish-white; in increasing proportions of blue. Green plus blue equals blue-green; in increasing proportions of blue. Red plus clear equals tints of red; in increasing proportions of clear light. Green plus clear equals tints of green; in increasing proportions of clear light. Blue plus clear equals tints of blue; in increasing proportions of clear light.

TALKS ON VICTROLA DEVELOPMENT

Addresses on Victrola Development by P. A. Ware, of Oklahoma Talking Machine Co., Proving Valuable as Sales Stimulators

OKLAHOMA CITY, OKLA., January 5.—The plan conceived by P. A. Ware, secretary and sales manager of the Oklahoma Talking Machine Co., Victor distributor, this city, for a series of short addresses on the development of the Victrola, is proving of undoubted value as a sales stimulator. Among the cities where the talks have already been delivered are Sapulpa, where Mr. Ware appeared at a Victor concert arranged by the local dealers at a meeting of the Chamber of Commerce, and at Tulsa, where arrangements were made by Mr. Ware with Thomas J. Edgar, of the Edgar Music Shoppe, live Victor dealer, to address the members of the Lion's Club.

LEOPOLD GODOWSKY IN JAPAN

Concerts Enthusiastically Received—Tour of China Included in Schedule

Oriental music lovers are enjoying a wonderful experience this Winter in the recitals of Leopold Godowsky, exclusive Brunswick artist, who is now playing in Japan. He gave five recitals in Tokyo at the Imperial Theatre with unprecedented success. Mr. Godowsky played in Yokohama, then in Kyoto, Kobe and Osaka. From Japan Mr. and Mrs. Godowsky go to China. Good news for the host of admirers of this great pianist's records is the word that he wrote three new pieces on the steamer from Vancouver to Yokohama.

Charles H. Stoll, music dealer of Okolona, Miss., is adding a talking machine department to his business.

BANNER 50c RECORDS

*If you changed places
with your customers!*

If you were a consumer, and discovered from your friends that you could buy full 75c worth of record value for 50c—you would take advantage!

And after you had tested the record—played it—liked it—considered it equal, perhaps superior, to records selling at 75c—you would continue to buy!

Place yourself in the other fellow's shoes and you will be better able to satisfy him. He knows the BANNER 50c Record. It serves his purpose and saves his money; and he is satisfied.

And you, in turn, will have greater sales. BANNER will bring more buyers to your store—more profits to you—bigger business!

Dependable "live wire" dealers who are interested in an exclusive proposition should write us at once. This is the season for the best results.

Watch the mails for "The Story of The Dealer Who Sidestepped the 50c Record"

PLAZA MUSIC COMPANY
18 West 20th Street NEW YORK

PREDICTS SPLENDID RECORD SALES

Phil Ravis, President of Peerless Album Co., Expects Vastly Increased Record Business— Gives Interesting Reasons for This Deduction

That record business during the first six months of 1923 promises to exceed in volume sales of any corresponding period over the past few years is the opinion of Phil Ravis, president of the Peerless Album Co., 636 Broadway, New York City. Mr. Ravis' close contact with many of the largest retailers of talking machines and the relationship of his product to the record industry gives him an interesting vantage point for observing this important phase of the industry. In conversation recently on the subject Mr. Ravis expressed his reasons for his belief, as follows:

"The extraordinary sale of instruments over the holiday season will inevitably be followed by a lively demand for records during the next six months. It is a well-known fact that all stocks of standard popular talking machines were completely absorbed in the Christmas rush and that numerous dealers experienced serious shortages in spite of the fact that production had been greater than ever. These new machine owners, as a whole, are mostly among a class that can afford constant indulgence in records as long as their enthusiasm is kept awake by the dealer. The record demand before us, therefore, is considerably more promising than that of 1919 and 1920.

"Another element which will play a big part in dealer returns, where records are concerned, is the noticeable revival in sales of standard and operatic selections in place of the populars and jazz. Peerless is preparing dealers to grasp the new opportunities which will come with this change by a further perfection of its classification system for Peerless album libraries.

"Long experience has demonstrated that the most enthusiastic record purchasers are those who begin the accumulation of record libraries

with definite classes of music, one class gradually evolving into another until the whole field of music is revealed and the extent of the dealers' stock is actually pitted against the customers' purse. It may appear as a time-worn statement, but I am sure that ninety-nine dealers out of every hundred will agree that the album is one of the best incentives to the new customer to collect records, just as a photo



Phil Ravis

album is conducive to taking frequent snapshots to complete its various pages.

"Peerless plans, during the new year, to gather from all reliable sources the newest and best selling plans and refer them to dealers who enter their names on our list. This clearing house of ideas has long been in operation in our office, but thus far only the regular Peerless customer list has been approached on the service. It is now planned to extend this service without cost or obligation to any talking machine dealer who applies for it."

Gualano Bros., Alhambra, Cal., have just opened a music store at 1827 N. Main street.

THE GREETINGS OF THE SEASON

The World Acknowledges and Reciprocates the Good Wishes of Its Friends.

The World takes pleasure in acknowledging and reciprocating the many expressions of good wishes for the holiday season and for the New Year that have been received at this office, those sending cards including: H. A. Weymann & Son., Inc., Ross P. Curtice Co., Curtice N. Andrews, Arthur A. Trostler, A. W. Rhinow, Import Sales & Business Agency, Inc., Standard Talking Machine Co., Emanuel Blout, W. J. Dyer & Bro., Steger & Sons Piano Mfg. Co., Oscar Willard Ray, the Orsenigo Co., Inc.; Regal Record Co., Penn Phonograph Co., E. F. Droop & Sons Co., Unit Construction Co., Orville Harrold, Cabinet & Accessories Co., Inc., Knickerbocker Talking Machine Co., R. M. Kempton, Aeolian Co., Marcel Wheat, P. A. Ware, Maurice Landay, Philip W. Simon, Thos. T. Evans, Harry A. Goldsmith, Morris R. Lamb, Superior Phonoparts Co., Lloyd L. Spencer, Arnold B. Reincke, James J. Davin, Otto Heineman, Silas E. Pearsall Co., Thos. F. Green, Ormes, Inc.; Earl W. Jones, John Cromelin, C. L. Johnston, Herbert A. Brennan, Richmond-Robbins, Inc., M. Witmark & Sons, Lambert Friedl, Ray Reilly, Daniel A. Creed, M. E. Schechter, Buffalo Talking Machine Co., James D. Moore, John A. Hofheinz, Howard J. Shartle, M. Steinert & Sons Co., Edward Wade Lundquist, Edward C. Rauth, John Steel, Ernest John, L. P. Mountcastle, Beckwith-O'Neill Co., H. B. Sixsmith and others.

ARTHUR FIELDS SONG SHOP OPENED

The Arthur Fields Song Shop has been opened in the Hotel Theresa Building, 125th street and Seventh avenue, New York City. In addition to talking machines and records a full line of sheet music and musical instruments is carried. The formal opening on January 2.

The New Granby Short Console
 Correct in Design Convenient in Size

"As Mellow as Southern Moonlight"

The Low List Price Assures a Heavy Demand \$135

The Trade Has Made a Discovery!

Phonograph retailers have been keeping their eyes open—and they have discovered a new model Granby that meets the demand for a short console—and that sells at a common-sense price:

The Granby

Adam Period Short Console Phonograph

Comes in rich walnut and brown mahogany. Has 5-ply veneered cabinet—equal to the veneers in higher priced instruments. Finished back and sides as well as in front. Construction guaranteed.

And Note these New Granby List Prices:

| | Was | Now | | Was | Now |
|-------------------------|-------|-------|--------------------|-------|-------|
| Sheraton Upright | \$140 | \$120 | Adam Console | \$275 | \$200 |
| Early Virginian Upright | 200 | 175 | Louis XVI Console | 325 | 250 |
| Louis XVI Upright | 275 | 235 | Queen Anne Console | 375 | 250 |

Granby Uprights, \$100 up; Granby Consoles, \$135 up

And with the fat, liberal Granby discounts the profits to you are worth going after. Write and ask for our attractive dealer proposition.

Granby Phonograph Corporation

Offices and Factory: NEWPORT NEWS, VIRGINIA

New York Branch: 37 WEST 20th ST., NEW YORK, N. Y. Tel. Watkins 4508

Thank You!

BAGSHAW Products have enjoyed their most successful year thanks to you dealers who have stocked and featured our wares. Thanks also to that great public which has recognized Bagshaw's high quality and bought generously.

Brilliantone, Reflexo and Petmecky Needles bid fair to duplicate in 1923 their successes of 1922. We are, indeed, oversold for the early part of the New Year. Dealers everywhere have apparently anticipated their spring requirements and placed their orders for future delivery.

We commend the wisdom of such dealers to those who have not as yet given thought to the brisk trade that will come with spring. Dealers who have already ordered will be assured of ample stock. They have protected themselves against possible price increases. They have placed themselves in a position to derive the greatest benefit from Bagshaw superiority. It is still time for you to do likewise. Place your orders now for Bagshaw products and make 1923 your best year.

W.H.BAGSHAW CO.

FACTORIES, LOWELL, MASS.

SELLING AGENTS

BRILLIANTONE STEEL NEEDLE CO. OF AMERICA
INCORPORATED

370 SEVENTH AVENUE

AT 31st STREET

NEW YORK

SUITE 1214

SUPERIOR STEEL
BRILLIANTONE
REGISTERED TRADE MARK
NEEDLES

SUPERIOR
BRILLIANTONE
REGISTERED TRADE MARK
NEEDLES

S
BRILLIANTONE
REGISTERED TRADE MARK
NEEDLES

BRILLIANTONE
REGISTERED TRADE MARK
NEEDLES

There Is Only One Reason For *Brilliantone Success*

And that is, the uniformly high quality of Brilliantone Needles.

They are absolutely dependable. The public has come to realize that a Brilliantone Needle will play a record as it should be played. They know that one Brilliantone Needle is as good as another; that they are safe in using Brilliantone Needles.

That is the reason for Brilliantone's popularity, for Brilliantone's success.

Our success in 1922 will be continued and furthered during the new year. This is already assured.

Wise merchants are forestalling possible necessary price increases. We have already booked many orders for Spring delivery.

Brilliantone Dealers have previously found it to their interest to heed our advice. We suggest that you place your orders now, at present prices, for your Spring requirements.

BRILLIANTONE
STEEL NEEDLE CO. OF AMERICA, INC.

Selling Agent for W. H. Bagshaw Co.
Factories, Lowell, Mass.

370 SEVENTH AVENUE NEW YORK

Canadian Distributors:
MUSICAL MERCHANDISE SALES CO.
79 Wellington Street, W. Toronto.

SUPERIOR STEEL
BRILLIANTONE
REGISTERED TRADE MARK
NEEDLES



The world and his best girl are a-tiptoe for a new expression of dance-music art. Paul Specht and His Orchestra are producing it. Your dancing customers will take keen delight in Columbia Record A-3759. "Away Down East in Maine" coupled with "One Night in June" have everything feet can desire.

Columbia Graphophone Co.
NEW YORK

DINNER OF EMPLOYEES OF GENERAL PHONOGRAPH CORP.

Interesting Program Prepared for Entertainment of Okeh Employees—Otto Heineman and Other Executives in Attendance—David Goldman Presides as Toastmaster

The employes of the General Phonograph Corp., New York, were the guests of the company recently at a Christmas dinner and dance given at the "Maisonette," one of the popular restaurants in the theatrical district. One hundred and twenty guests were present and throughout the evening the program was thoroughly enjoyed by all in attendance.

Otto Heineman, president of the company, accompanied by Mrs. Heineman, were the

forts in this direction contributed materially to the success of the evening. John Dean, general manager of the needle factory at Putnam, Conn., made a special trip to New York to be present at the dinner.

Fred W. Hager, director of the Okeh recording laboratories, was in charge of the music and dance program, and with his usual capability provided the guests with splendid entertainment. Billy Jones, well-known recording artist,



Forces of General Phonograph Corp. Guests of Company at Dinner at "Maisonette"

guests of honor, and the dinner served as a "bon voyage" from the employes to Mr. and Mrs. Heineman, who sailed a few days later for Europe. Among the other executives in attendance were Mr. and Mrs. W. G. Pilgrim, Mr. and Mrs. Adolph Heineman, Mr. and Mrs. Jacob M. Schechter, W. C. Fuhri, Paul Gloetzer, J. A. Sieber, R. S. Peer, F. W. Hager, A. F. Thallmayer, E. L. Sampter, E. B. Shiddell and others. David Goldman, auditor of the company, presided as toastmaster, and his ef-

avored the diners with several of the hits he has made for Okeh records, and Joseph Samuels with his orchestra provided the latest fox-trot hits for terpsichorean artists of the Okeh organization.

Bame's, Inc., one of the largest talking machine houses in Atlanta, Ga., recently added the Okeh records and a vigorous campaign in the interest of this line is under way. Advertising and other sales producers are being used.

TALKING MACHINE TRADE IN INDIA

American Talking Machines Sold Through British Agencies—Opportunity for Study to Increase Sales by American Exporters

WASHINGTON, D. C., January 4.—American talking machines are being sold in Karachi through British agencies, which have opened branches in the city and established a supply organization to furnish records and parts, according to advices from Consul A. M. Warren, Karachi, India. The long delay between the production of topical, musical and dance records in America and their appearance in the Karachi markets tends to reduce the sales.

German products have been entering the market during the last six months. Motors and sound-box apparatus for German talking machines are exported to India and are assembled with Indian-made cabinet cases. In the same way the metal parts of pianos are manufactured in Germany and exported to India, where they are placed in Indian-made cases and sold at unusually low prices.

In view of this competition it behooves American manufacturers of musical instruments to give careful consideration to the problem of marketing their products in Karachi and other Indian cities in the most economical and efficient manner.

MOURNS PASSING OF MOTHER

Mother of John Y. Shepard Passes Away at Home in Gloversville, N. Y.

John Y. Shepard, associated with the wholesale sales staff of the Okeh distributing division of the General Phonograph Corp., 15 West Eighteenth street, New York, is mourning the death of his mother, Mrs. Alice McGee Shepard, who passed away recently at her home in Gloversville, N. Y. Mrs. Shepard was in her sixty-ninth year and she leaves two sons and a daughter.

Mr. Shepard is the Brooklyn, N. Y., representative of the General Phonograph Corp. and is widely known to the trade in the metropolitan district.

VICTOR CO. DECLARES DIVIDEND

Directors of the Victor Talking Machine Co. recently declared the first dividend on the common stock since the capital of the company was increased last month. The dividend amounts to \$2 a share quarterly and is payable January 15 to stock of record December 30. The regular dividend on the preferred was also declared payable as of the same dates. The dividend of \$2 a share declared on the common stock is equal to \$14 a share paid on the old stock before the stock dividend was distributed.

The Hartwell Furniture Co., Hartwell, Ga., recently added a talking machine department to its business.

Okeh Records

STRAND, GRANBY and OUTING PHONOGRAPHS

Brilliantone, True Tone, Tonofone and Gilt-Edge NEEDLES
DELIVERY BAGS AND ACCESSORIES

Complete Stocks and Prompt Service

IROQUOIS SALES CORPORATION

Wholesale Distributors

210 Franklin Street

BUFFALO, N. Y.



**Plays EDISON
Records**

THE
“VICSONIA”
REPRODUCER

Truly a Reproducer that will please the most cultured musician and discriminating critics. For over nine years the recognized medium for playing EDISON Records on VICTOR and COLUMBIA Machines.

Made in Silver and Gold. Fitted with Sapphire or Diamond Point.
One Silver, Sapphire Point Reproducer Sent on Receipt of \$4.50.

VICSONIA MFG. CO., Inc., 313 E. 134th Street, New York, N. Y.

LESLIE I. KING WITH BRUNSWICK

Former Talking Machine Man Becomes Sales Manager in Central Division With Headquarters in Cleveland—Has Had Wide Experience

COLUMBUS, O., January 3.—Leslie I. King, formerly manager of the Morehouse-Martens Co., this city, has, beginning with the first of the year, taken up his new duties as sales manager for the Brunswick-Balke-Collender Co. in what is known as the central division, taking in the cities of Cleveland, Pittsburgh, Buffalo and Rochester, making his headquarters in the first-named city, where he will establish a branch office.

Mr. King, who has had wide experience in the talking machine field, came to Columbus six years ago and as manager of the Morehouse-Martens Co. department developed a number of modern sales ideas that were most successful and increased the business volume by over 1,000 per cent.

He conceived and laid out a department that was regarded as a model of its kind and was likewise successful in developing prospects outside the store through the distribution of toy banks and by other means. He was also president of the Central Ohio Retail Victor Dealers' Association, which office he relinquished upon

assuming his new duties with the Brunswick Co. Mr. King is already developing service plans for the benefit of Brunswick dealers, one of the



Leslie I. King

plans calling for what is known as a resale department, from which trained salesmen will be sent out to dealers to help in drilling new sales people hired in retail establishments.

EASTERNERS MAKE GOOD IN WEST

Scott Bros. Coming From the East Win Success in General Music Business in Wyoming

The success of the Scott Bros. Music Co., Greybull, Wyo., is a reflection of Horace Greeley's advice to young men to go West, for the Scott Bros. both originally learned the business in the East, and, in fact, with Chickering & Sons to be exact, and have now built up a very substantial business in Greybull, handling pianos, players, Victrolas, musical merchandise and sheet music. They report that the holiday trade has been exceptionally good.

LEASES LARGE STORE ROOM

The Graber & Gray Music House, Main street, Visalia, Cal., in the Hotel Johnson Building, has leased the store room at 426 East Main street. This room will be used for warehouse purposes, for storage of pianos, phonographs and other musical instruments and supplies. Rapidly expanding business made larger space necessary.

Clemons Bros., of Chattanooga, Tenn., who conduct a Victor department in their furniture store, recently moved into their own new building in that city.

OUR INSTRUMENTS POPULAR IN CHINA

Foreign-educated Chinese Responsible for Rapidly Growing Popularity of American-made Pianos and Talking Machines

WASHINGTON, D. C., January 6.—Foreign music is growing more popular with the foreign-educated Chinese, who are constantly increasing in number, according to Consul General P. S. Heintzleman, stationed in Hankow. They cultivate this taste while studying in the schools and colleges conducted under the auspices of the various foreign governments and mission societies. Piano, organ and talking machine music is equally popular with them.

Talking machines, which are comparatively cheaper in price, are very popular in China and nearly every foreign family and wealthy Chinese family in the treaty ports, which has come under foreign influence, possesses one. They are purchased from selling agents in Shanghai. While talking machines have only a limited sale among the natives, because of their price, it would seem that an instrument of moderate price would have a wide distribution if it were properly advertised and marketed. Chinese records should be sold with any machine intended for the Chinese.

In order to bring American musical instruments to the attention of the Chinese it would seem necessary to work through one of the long-established foreign firms at Hankow.

Reinald Werrenrath, Victor artist, recently appeared before a capacity audience at the Atlanta Auditorium, Atlanta, Ga.

**Ward's Padded Khaki
Moving Covers**



for
**Pianos
and all
Models of
Upright
and
Console
Machines**

Distributors
BRISTOL & BARBER, INC.
3 E. 14th St. New York City
SHERMAN, CLAY & CO.
741 Mission St. San Francisco, Calif.

THE C. E. WARD CO.
Manufacturers
NEW LONDON OHIO

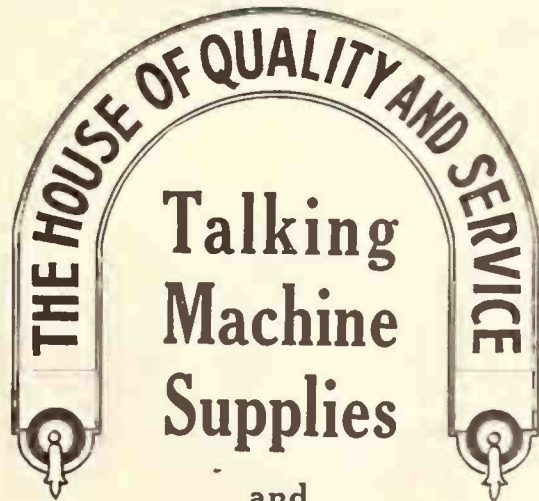

and
Repair Parts

SAMUEL ESHBORN
65 Fifth Avenue
New York



Mardones' has been called the most beautiful bass voice in America. He has just made a marvelous record of the "Ava Signor" from Boito's *Mefistofele*. The vastness of his voice never shone to better advantage. Coupled with this is "Golondron" from the opera *Maruxa*. Mardones sings this in Spanish, his native tongue. A-6225.

Columbia Graphophone Co.
NEW YORK

EFFECTIVE PUBLICITY STUNT

Black, Derges & Marshall, Phonograph Dealers in Peoria, Ill., Obtain Publicity With Help of Dance Hall Management—Fine Publicity

PEORIA, ILL., January 4.—Black, Derges & Marshall, Brunswick dealers of this city, have an arrangement with the management of the Inghaterra Ball Room here which is resulting in considerable valuable publicity. The orchestra stand is in the center of the floor, a raised pagoda-style pavilion. When a piece is being played a card is inserted in an attractive frame, giving the number of the Brunswick records. The Inghaterra is the finest and largest dance hall in Illinois outside Chicago, and Isham Jones' Orchestra recently played a special engagement there under the auspices of these dealers.

APPOINTS MANY NEW AGENCIES

Among the many new agencies throughout the country recently appointed by the Brunswick Co. are included the Milford Pharmacy, Milford, Utah; Don. F. Kugler, Soda Springs, Iowa; John F. Boyden & Sons, Coalville, Utah, and Simmons Pharmacy, Springville, Utah.

The Bruce Co., of Springfield, Ill., has just changed retail managers, V. V. Williams, formerly manager of the Peoria store, succeeding A. W. Wolfe.

ANNOUNCE THREE NEW SONORA MODELS

Two Console Period Models and One Upright Added to Line—Well Calculated to Assist Sonora Dealers in Developing 1923 Business

The accompanying illustrations portray three of the new Sonora period models for 1923 known as the Marlborough, Serenade and Bar-



Marlborough

Barcarolle

Serenade

carolle. The Marlborough and Serenade are additions to the standard period Sonora line that will undoubtedly give added prestige to Sonora product in general. The list price of the former is \$185 and the latter \$150.

The Barcarolle has many of the features of the baby grand Sonora, including the costly

bulge construction, an exclusive Sonora feature. At a list price of \$150, or \$50 less than a baby grand, it will undoubtedly be one of the big Sonora sellers this year.

ORMES, INC., PRESENTS FINE GIFT

In accordance with its usual custom, Ormes, Inc., 15 West Thirty-seventh street, New York,

Victor wholesalers, forwarded on Christmas to their friends in the trade a handsome gift. This year's Christmas greetings consisted of a very attractive eight-day clock in mahogany, accompanied by a greetings card expressing the company's hope that 1923 would bring unbounded prosperity and happiness to the recipient. The clock was enthusiastically received by the trade and C. L. Price, vice-president and general manager of Ormes, Inc., has received many letters congratulating the company on the practical value of its Christmas gift.

PATERSON, N. J., SHOP ENLARGES

PATERSON, N. J., January 4.—Extensive alterations and enlargement have been made by O'Dea's Phonograph Shop, 115 Ellison street, this city. The entire second floor has been converted into additional demonstration rooms, making in all twenty-six rooms for the display and demonstration of machines and records.

BRUNSWICK CO. FEATURES THRIFT

A special advertisement has been prepared by the Brunswick-Balke-Collender Co. to be used by Brunswick dealers during Thrift Week, January 17-24. This advertising will be used as a tie-up with the Brunswick Thrift Bank campaign urging prospective Brunswick buyers to visit their local stores to secure Brunswick thrift banks, designed to speed Brunswick sales.

OPENS NEW JENKINS STORE

The J. W. Jenkins Sons Music Co., operating a chain of stores in Kansas, Oklahoma, Missouri and Arkansas, has just opened the fourteenth store at Wichita, Kan.

Sherburne Automatic Stop

Stops When You Want It to Stop

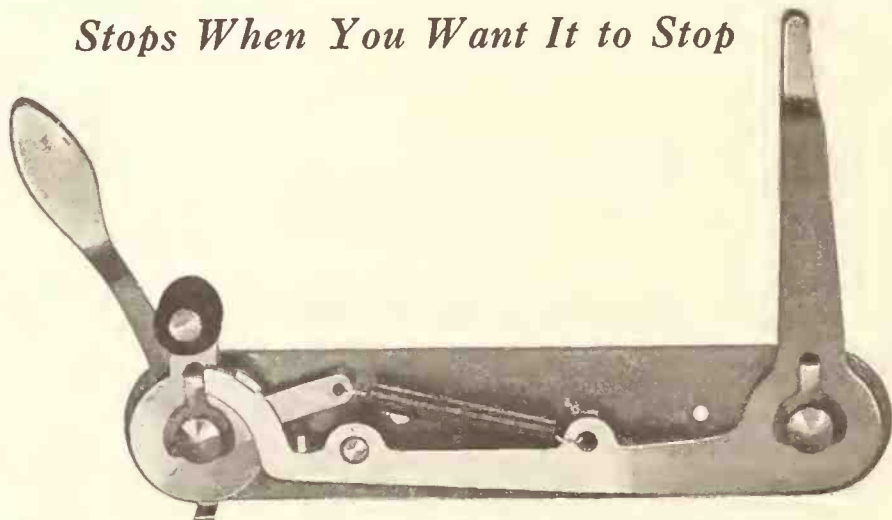

Manufacturers: Has *your* automatic stop ever helped your dealers make a sale?

Investigate the Sherburne

Sample sent upon request

SHERBURNE MANUFACTURING COMPANY
948 Penobscot Building
Detroit, Mich.

QUALITY

Counts More Than Ever

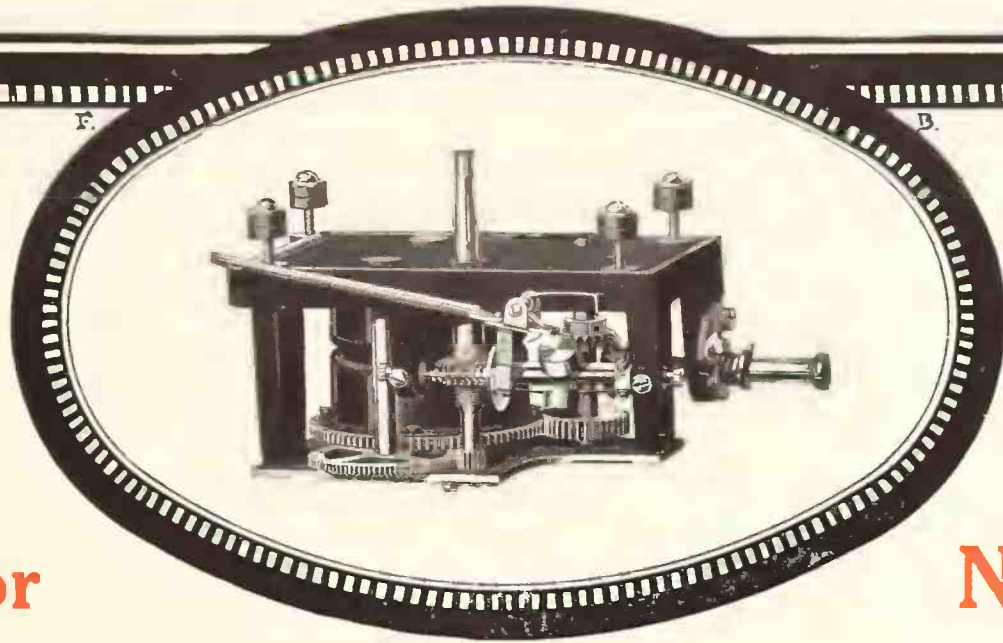

Motor

No. 77

The Famous Motor of Quality

Noiseless, powerful, steady
and continuous

*In these times of keenest competition,
Machines equipped with*

HEINEMAN QUALITY MOTORS

will invariably be the winners

General Phonograph Corporation

OTTO HEINEMAN, Pres.

25 West 45th Street New York

HEINEMAN



MEISSELBACH

Soft shadows play, Flowers sway, Neath the Jap-a-nese Moon, There in its light, Ev'ry night, Little Jap-a-nese croon,

JAPANESE MOON

ANIPPONESE NOVELTY

HEAR IT NOW!

"You can't go wrong With any FEIST song"

EFFECTIVE RAY MILLER PUBLICITY

Exclusive Columbia Artist Captures Detroit's Dance Lovers—Dual Engagement Works Out Profitably for Talking Machine Dealers

DETROIT, MICH., January 6.—Columbia dealers in Detroit co-operated to advantage in the development of a gigantic publicity campaign featuring Ray Miller and his orchestra, exclusive Columbia artists, who were booked by the Fox-

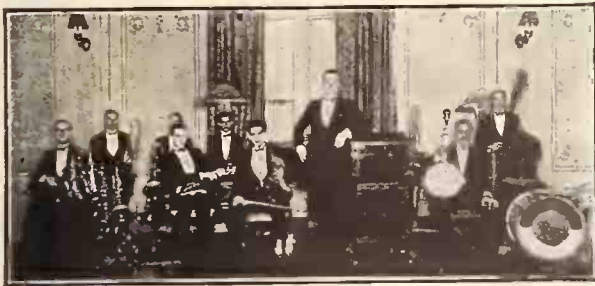

The Ray Miller Orchestra Washington Theatre and the Addison Hotel in this city. Many thousand folders announcing the engagement of Ray Miller and his orchestra were sent out by these two places and included in the folder was a photograph of the orchestra with a list of Ray Miller's records.

The orchestra's opening night at the Addison Hotel was advertised as "record night" and every lady in attendance was given a Ray Miller Columbia record in a Columbia record gift envelope as a souvenir of the occasion. At the

Fox-Washington Theatre, on a Monday night, after playing two weeks, the crowd was so enormous that many admissions were refunded. This is particularly gratifying when it is considered that Monday is usually the worst theatre night of the week in Detroit.

In the beautiful ballroom of the Addison Hotel after Ray Miller's Orchestra had played to the limit and stopped for the night the crowd often refused to leave the crystal dance floor. They took possession of an L-2 Grafonola on the orchestra platform and with a supply of Columbia dance records these enthusiastic devotees were able to carry on with their dancing through the remaining hours before daybreak.

S. E. BROWN IN NEW POST

Succeeds E. N. Upshaw as President of the Southern Sonora Co.—Concern Moves to Attractive New and Large Quarters

ATLANTA, GA., January 7.—E. N. Upshaw, formerly president of the Southern Sonora Co., distributor of the Sonora line in Georgia, Alabama, Florida and North and South Carolina, recently resigned from the company to devote his entire time to the automotive equipment business. He is succeeded by S. E. Brown, who has been connected with the company for the last two years and prior to that was associated with the Elyea Talking Machine Co., Victor distributor.

The Southern Sonora Co. recently moved into attractive quarters at 293 Peachtree street. The business of the firm has been growing steadily and the move was thought advisable in order to facilitate the handling of the business.

NEW QUARTERS IN NEW ORLEANS

Junius Hart Piano House, Ltd., Leases Four-story Building on Carondelet Street to Be Occupied Late Next Year After Alterations

NEW ORLEANS, LA., December 23.—The Junius Hart Piano House, Ltd., has just closed a lease of the premises at 123-25 Carondelet street, a four-story building at present occupied by F. F. Hansell & Bro., who will move to a new location on October 1, 1923, when the music house will take possession on a ten-year lease. George A. Stocker, vice-president and general manager of the Junius Hart Piano House, looked after the details of the deal and stated that the building would be remodeled extensively before being occupied by his company. The consideration involved is not announced, but is understood to be in the neighborhood of \$150,000.

The latest addition to the music stores of San Bernardino, Cal., is the Orange Belt Music Store, opened by "Jeff" Christmann and J. W. Foote at 626 Third street. A complete line of pianos as well as musical instruments is handled.

Mr. Edison Man:—

Don't Say

"KAN'T," say "KENT"

Write for catalog of complete line

The KENT No. 1

With "S" Sound Box

Has given complete satisfaction for years

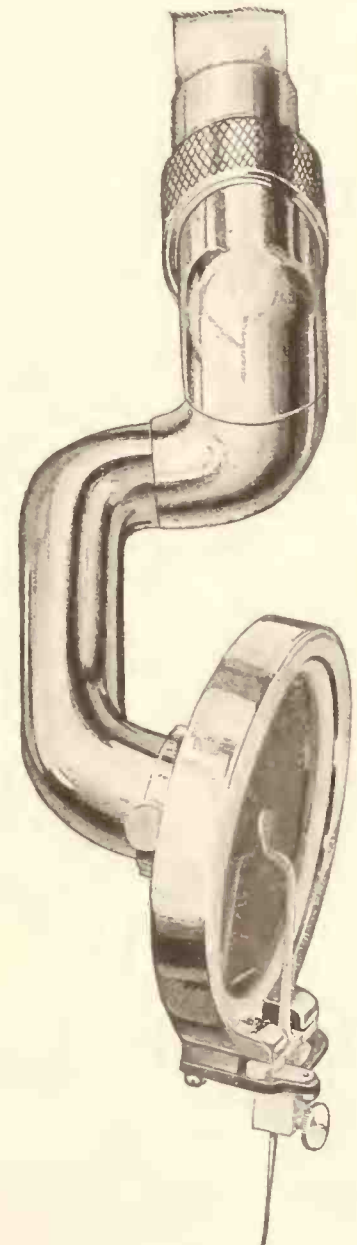

Reg. U. S. Pat. Off.

F. C. KENT CO.

Irvington, N. J.

Victor Wholesalers



The House of Mellor in Pittsburgh since 1831



Guyon's Paradise Orchestra

(JULES R. HERBUVEAUX, Director)

records exclusively for

OKeh Records

The Records of Quality

DANCE RECORDS by this popular organization are in marked demand. Their really unique, yet harmonious interpretations of the modern dance music, without the slightest loss to the proper rhythm, have won for them the praise and instantaneous approval of thousands of dance-lovers.

Records by this, or any other OKeh artist or organization, may be obtained from Consolidated with the same promptness and smooth efficiency that are always so characteristic of

CONSOLIDATED SERVICE

Consolidated Talking Machine Co.

227 W. Washington Street

Chicago, Ill.

Branch: 2957 Gratiot Avenue, Detroit, Mich.

The Status of Radio in the "Talker" Store

By R. F. STAYMAN, Advertising Manager, Crosley Mfg. Co.

Tremendous and rapid expansion of the radio business makes it hard even for those closely connected with the industry to predict who will be the ultimate dealers, but it is safe to forecast that those engaged in the retail sale of talking machines soon will find themselves face to face with a strenuous demand for receiving sets and parts. This is one of the inevitable sequences of events in connection with the development of the trade, and wise indeed will be the dealer who prepares immediately to meet this demand.

There are some who insist the electrical dealer will be the logical one to handle radio. They are correct in their assertion, but the electrical dealer will not be the only logical one. There are many engaged in various lines of retail trade to whom the radio business will appeal, but there naturally are a few who will do the bulk of the business, and included among these few are the talking machine dealers.

Without doubt every phonograph man in the United States has considered adding radio receiving apparatus to his line, but some have held back for various reasons, chief of which is a misunderstanding regarding the amount of experience necessary in successful operation of the business. As soon as they realize radio is one of the most simple of modern inventions, then will they know they erred in refusing to reap the harvest of gold that was placed before them.

Radio and music are moving along hand in hand, the former depending entirely upon the latter. In fact, if it were not for music radio rapidly would pass into oblivion. But on the other hand, radio is increasing the demand for music, owners of receiving sets purchasing selections they have heard coming from the broadcasting stations. One without the other is lost, and still, taken together, they form what the user of slang would say is a combination that is hard to beat.

Radio receiving sets are amusement producers, so are talking machines. They permit hearing of the same music that is heard by means of the phonographs. They operate on the same principle—reproduction of the human voice—although the radio does not exactly reproduce this voice, it carries it. They are being installed in the same cabinets and in certain cases by the same manufacturers.

Now too much emphasis cannot be placed upon the simplicity of radio and upon the ability of any person to operate a set. Remember when the automobile first came out and you said you never would learn to run such a thing? Would you admit now that you could not learn to operate a car? Certainly not, and so you cannot admit you are afraid you will be incapable of successful operation of a radio set. The terms are strange to you, no doubt, but they are simple. The different parts and accessories may seem beyond human understanding at first, but the mystery clears in a remarkably brief period, and after a few hours of reading and "tinkering" any person will be able to talk radio intelligently enough to explain to customers the pleasures and benefits to be derived from ownership of sets.

Many talking machine dealers have been surprised at the small amount of space necessary for the addition of this line, at the quick turnover, at the manner in which radio instruments attract new customers to their stores and, most important of all, at the large profits obtainable. Manufacturers and jobbers are giving from 25 to 50 per cent discounts, depending, of course, upon the size of orders, so it may readily be seen that with a tremendous demand the possibilities of increasing profits are such that they cannot be overlooked.

There is another mistaken idea that has led certain dealers to hold aloof, and that is the

belief that a large amount of money must be invested. This may have been so several years ago, but not to-day. People are demanding low-priced but efficient apparatus. In fact, for but a few hundred dollars any dealer may purchase a trial stock including a wide variety of receiving sets and parts. For instance, the Crosley Mfg. Co. prepares trial orders for new dealers, the total amounts ranging from about \$200 to \$500, these orders consisting of everything necessary in meeting the initial demands of customers. With a wide-awake dealer, however, this supply should not last more than a few days and so all who enter the business should be prepared for almost immediate repeat orders.

There is no line comparable with radio when advertising is considered. It appears that there is something about this that attracts people,

draws them to display windows and into stores. Handling of radio sets and parts is a sign of progressiveness—and we all are more or less progressive.

SPLITTING HAIRS ON DIVIDEND

Final Dividend Announcement of Mozart Talking Machine Co. Features Percentages Worthy of Attention of Mathematicians

St. Louis, Mo., December 30.—Walter D. Coles, referee in bankruptcy, has announced that a fourth and final dividend of 55,313/100,000 of 1 per cent has been declared on all claims allowed against the estate of the Mozart Talking Machine Co., this city, said dividend to be paid by the trustee, Milton D. Mendle, at his office here on or after January 8.

A loss of \$4,500 was incurred recently by the A. J. Bensberg Music Co., Washington and Adams streets, Camden, Ark., in a fire.

THE SILENT MOTOR

Unsolicited Communications from Talking Machine Manufacturers Testifying to the High Quality of Our Motors.

One of the largest manufacturers of talking machines in Ohio states:

"We congratulate you upon the high state of efficiency maintained in the quality of your motors and trust that our finished product will always measure up to the high standard you have demonstrated in the manufacture of your product."

Another successful manufacturer of phonographs in Pennsylvania states:

"For your information would say that all your motors are giving satisfaction, no trouble of any kind has developed and in the future all of our cabinets will have your motors installed as standard equipment."

One of the largest phonograph manufacturing concerns in Indiana states:

"Your motor is a very good motor and we particularly admire the speed control."

Another large manufacturer of phonographs in Pennsylvania states:

"Your motor is very good, in fact one of the best we have ever seen."

Motors manufactured in three models which are guaranteed to play in excess of two, three and five records. Samples and prices on request.

THE SILENT MOTOR CORPORATION

CHARLES A. O'MALLEY, President

321-323-325 Dean Street

BROOKLYN, N. Y.

Ogden's Sectional Phonograph Store Equipment

— STANDARDIZED —

Produced economically in great quantities—sold to you as you need it. Every part accurately made to fit the other. You can keep adding to your equipment as your business grows or knock it down and move it to your new quarters.

Construction and Finish the Best—At Factory Prices.



OGDEN'S SECTIONAL STORE EQUIPMENT.

The complete Store Equipment (as illustrated) consists of RECORD RACKS, for 2,700 10-inch and 12-inch Records —SALES COUNTER with every Dealer convenience for Card Files, Accessory Stock, Bags and Wrapping.

SOUND-PROOF BOOTH, 6 x 9 ft., (Plan No. 5). For Corner of Store, \$315.00. Against Side Wall, \$365.00. Without Wall Contact, \$415.00. (Complete as illustrated.)

ANY MAN AND A BOY for helper without carpentry experience can assemble this room in one hour. There is nothing to do but place Wall and Door Sections in the Pilaster and turn down the clamps. Place Ceiling units in position and Base Rail or Floor Shoe around the bottom and the job is complete, as tight as a drum, at a fraction of the usual cost.



Room units made to fit sound tight

Price of Ogden's Sectional Units

| | |
|--|---------|
| Record rack, No. 1-S, each..... | \$40.00 |
| Paneled ends, each..... | 5.00 |
| Record sales counter, No. 1-S, each..... | 80.00 |
| Record sales counter, No. 2, each..... | 60.00 |

FINISHES:—GENUINE ENAMEL
White, Old Ivory and Gray



FRONT VIEW OF RECORD SALES COUNTER #1
TOP 30" X 60" 32" WITH CASTORS

BACK VIEW OF RECORD COUNTER #1
SHOWS 3 DRAWERS WITH ADJUSTABLE COMPARTMENT DIVIDERS, ALSO 3 UPRIGHT COMPARTMENTS AND 2 SHELVES

FRONT AND BACK VIEW OF RECORD COUNTER, showing 3 compartment drawers for Card Files, also 3 Upright Compartments and 2 Shelves, which fill every Dealer requirement.

Materials are rapidly advancing. Make your reservations NOW to protect you against price advances during 1923. By outlining your plans for the future now will give you price protection.

Prices of Complete Equipment

| | |
|--|----------|
| PLAN NO. 1—2 Record Sections, 1 Sales Counter, 1 6x6 ft. Booth.. | \$275.00 |
| PLAN NO. 2—3 Record Sections, 1 Sales Counter, 2 6x6 ft. Booths.. | 425.00 |
| PLAN NO. 3—2 Record Sections, 1 No. 1 Sales Counter, 1 6x6 ft. Booth | 305.00 |
| PLAN NO. 4—3 Record Sections, 1 Sales Counter, 2 6x6 ft. Booths.. | 460.00 |
| PLAN NO. 5—2 Record Sections, 1 Sales Counter, 1 6x9 ft. Booth.. | 315.00 |
| PLAN NO. 6—3 Record Sections, 1 Sales Counter, 2 6x9 ft. Booths.. | 475.00 |

6 PLANS OF OGDEN'S STANDARD SECTIONAL STORE EQUIPMENT

This to be used to assemble any size Rooms in units of 3ft and any arrangement required for any space.

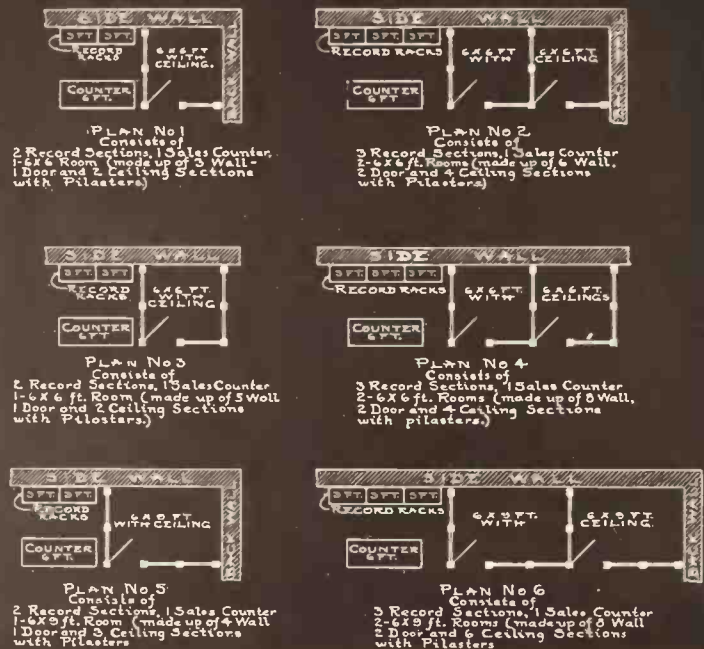

Scale - 1/4" = 1 foot

Ogden's Complete Modern Store

Costs less than carpenter work. Everything ready for business the day you get it—Sectional—Unpack and "Set it up Yourself."

NOW IS THE TIME TO IMPROVE YOUR SERVICE

Send us a pencil Sketch of your Store, Showing where you want Record Racks, Customers' Counters and Private Salesrooms and we will quote you a delivery price on Sectional Equipment which you can install any evening and be "Up to Date" next day.

OGDEN SECTIONAL CABINET CO., Lynchburg, Va.

For pure melodious excellence you'll go far before you hear a finer record than A-3748—It's the Criterion Quartet singing "Drifting Down" and "Sometime, Somewhere." The beautiful blending of these rich male voices, unaccompanied, suggests the masterly playing of a deeply sonorous wood-wind instrument.

**Columbia Graphophone Co.
NEW YORK**



SAN FRANCISCO

Record Holiday Demand—Console Models Lead—Passing of Mrs. L. S. Sherman—Phonograph Studio Enlarged—G. Q. Chase Home

SAN FRANCISCO, CAL., January 3.—Christmas business in California was the best in years. The weather had been unfavorable up to Christmas week, then came a change and the stores were crowded for one solid week. The people showed a most decided preference for flat top machines, especially in the period styles, and they seemed to have plenty of money for cash payments. High-grade merchandise was readily placed where cheaper goods were expected to sell best. Some of the San Francisco dealers hold the opinion that the great interest in higher class goods is directly due to the work of music week and the music memory contests, which undoubtedly stimulated musical interest to an unusual degree this year. On the other hand the country has become prosperous and the people have funds to spend. People have never dressed better, bought better house furnishings and lived better than in the past year in this country. Living standards have steadily ascended in the scale. Some attribute the increased purchasing power of the people most largely to prohibition.

Demand for Better Grade Goods

J. J. Black, of the Wiley B. Allen Co., says the holiday business of the San Francisco store and all the branches shows a creditable increase over last year. More high-class machines were sold and many more records. The sale of classic records for Christmas gifts was unexpectedly large. The Wiley B. Allen Co. is noted for the artistic excellence of its show windows and the Christmas windows this year, though quiet in tone, were fully up to the traditional standard. R. W. Young, manager of the Fresno store of the company, was in San Francisco this month and he spoke enthusiastically of music week in Fresno. They also had a very successful music memory contest in Fresno in the latter part of December.

Art Models Popular

George E. Morton, manager of the talking machine department of the White House, San Francisco, says the greatest interest shown by the patrons of his department was for the beautiful art models of the Victor and Cheney lines. Period styles of the flat top and console type go the best as a rule.

Death of Mrs. L. S. Sherman

The trade expresses its sympathy for Leander S. Sherman in his great bereavement through the death of Mrs. Sherman on Sunday, December 17. Mrs. Sherman was a musician of talent and an active club and charity worker in San

Francisco, where she had lived most of her life. She was seventy years of age at the time of her passing.

Phonograph Studio Expands

The Phonograph Studio, at Powell and O'Farrell streets, has just been greatly enlarged by the addition of considerable space leased at the rear and on the Powell street front. The Powell street show windows are now more than twice their former size, while the added space at the rear affords room for fourteen demonstration booths. The entire store has been redecorated in old ivory, with Oriental decorations for the electric light fixtures. Each record booth is equipped with a push button service so that customers may be more conveniently served and each room is named after some famous artist. The artist's portrait in colors hangs in each respective booth. The Phonograph Studio has taken the agency for the Conn line of band instruments and the mezzanine floor is being altered and equipped especially for the band instrument department. The company also handles player rolls and popular sheet music. Manager Quarg says the business in merchandise orders was very heavy, principally on account of the poster in each booth calling attention to the advantages of purchasing merchandise orders as Christmas gifts. Novelty records had a large sale during the holidays.

Evening Business Proves Lively

The Phonograph Shop, on Stockton street, like most of the other talking machine stores, kept open evenings the week before Christmas. Mr. Compton, the manager, says the Christmas demand was splendid and that the popularity of period styles, especially the consoles, was greater than ever, both in Victor and Sonora machines.

George Q. Chase Home From Hawaii

George Q. Chase, of Kohler & Chase, has returned from a trip to the Hawaiian Islands and it is rumored that he may open a branch store in Honolulu. He did not deny the rumor, but would not commit himself to a definite statement. The phonograph business in the California store was heavy during the holidays, and Okeh records moved well, as usual. The new styles in Burnham machines have proven ready sellers.

Strong Pathé Campaign

There has been quite a revival of interest in Pathé machines and records the last few weeks as the result of a vigorous selling campaign conducted by Emil Greenbaum, of the Western

Phonograph Corp. The Pathé Actuelle is on sale in a number of prominent stores in the San Francisco Bay region and its popularity is growing steadily.

Good Publicity for Hackett Records

The recent concert in San Francisco by Charles Hackett, the noted tenor, was the signal for a bit of telling publicity work by Mr. Kantner, the manager of the San Francisco office of the Columbia Graphophone Co. He presented each guest of the Hotel Fairmont who happened to have a phonograph in his or her room with a Hackett record. The result was that Mr. Hackett, who was staying at the hotel, heard himself sing morning, noon and night while in the city. Heavy sales of Columbia merchandise are reported. The Style Music Co., of Oakland, alone took a full carload.

Stocks Prove Inadequate

Robert Bird, manager of the wholesale Victor department of Sherman, Clay & Co., San Francisco, says that, in spite of the extra shipments made in anticipation of a heavy Christmas business, the available supplies were not enough for the full demand.

H. N. McMenimen Consulting Engineer

Consultation by appointment on every phase of the phonograph industry, including:

Recording, Plating and Pressing

Motor, Tone-Arm and Reproducer Design

Patent and Model Development

Sales Promotion and Advertising Plans

Laboratory:

Scotch Plains, N. J.
Tel. Fanwood 1438

Offices:

2 Rector Street, New York
Tel. Rector 1484

**PHONOMOTOR PRODUCTS, PHONOSTOPS and NEEDLE CLIPPERS
ALWAYS THE BEST**

PHONOMOTOR COMPANY

121 WEST AVENUE, ROCHESTER, N. Y.

in a corner of the world, — We will build our home, sweet home.

In A Corner of the World All Our Own

Jesse Crawford's
Beautiful Ballad

"You can't go wrong
With any FEIST song"

M I L W A U K E E

Year Just Closed Is Historic in Annals of Good Business—Lake Laboratories in Radio Field—Kaun Co. Reorganizes—The News

MILWAUKEE, Wis., January 10.—If anyone had said a year ago that the talking machine business in Milwaukee as a whole during 1922 would break all records he undoubtedly would have been set down as "talking through his hat." For at the opening of last year, despite the improvement already noted and the greatly improved prospect after the depression, there was none so sanguine that a prediction of record-breaking business in this industry seemed substantially based or was more than a wild prophecy.

But it did come to pass. The local trade wound up 1922 with more sales and a greater volume of business, on a money basis as well, than any previous year, and even the wonderful year of 1919 was surpassed by most retailers with a good margin to spare.

From what has already transpired in the first ten days of the new year local distributors and jobbers feel confident that 1923 is going to be even a bigger and better year than the last one. The passing of the holiday season left the floors of virtually all stores practically bare of merchandise, and record stocks were "shot to pieces" by the phenomenal demand,

particularly during the last three weeks before Christmas. Replenishment is now going forward, with the result that jobbers are doing a rushing business. They are unable to fill anywhere near the total of replacement orders, although most dealers are proceeding with conservatism and spreading delivery dates over periods ranging from thirty to ninety days.

Fred E. Yahr Enthusiastic Over Business

Sonoras "went big," and Fred E. Yahr, head of the Yahr & Lange Drug Co., distributor in Wisconsin and Upper Michigan, said that nothing like the holiday business of 1922 has ever been known. Dealers in many cities begged for merchandise two weeks before Christmas and some drove their cars into Milwaukee to pick up as many Sonoras as they could be allotted, not trusting railroads or express to get goods in time.

New High Record for Brunswick Sales

One of the sensations of the Milwaukee trade in the past holiday season was the Brunswick. While this line made brilliant progress all through the year the windup witnessed a relatively enormous demand which depleted dealer as well as distributor stocks. The local branch

of the Brunswick-Balke-Collender Co. was obliged to send representatives to the factory and keep wires hot with other branches to get supplies of instruments as well as records. In Milwaukee a new high record for retail sales was set up by the J. B. Bradford Piano Co., which, it is intimated, gives Bradford's first place among all Milwaukee retail representatives at the same time that the other big dealers shattered every previous mark for sales.

Victor Shortage Also at Interior Points

But the Milwaukee retail trade is not alone in ordering goods in quantity. Dealers in the interior experienced much the same overwhelming demand as metropolitan stores and they need goods badly. Harry Goldsmith, secretary of the Badger Talking Machine Co., Victor jobber, said that the condition of stock shortage appears to be general all through Wisconsin and the upper peninsula of Michigan. Never in his long experience, Mr. Goldsmith said, were rush orders prior to Christmas so plentiful as last December, and the jobbing warehouse was bare of stocks when the holidays rolled around.

Immense Columbia Output

More Columbia records were sold in Milwaukee and vicinity during the last three months of 1922 than in any similar period in the long history of the industry. Grafonola sales likewise surpassed every previous mark. Dealers entered the new year with little or nothing on their floors.

Clean Sweep for Edison

It was pretty much of a clean sweep for Edison, too. The local Edison branch described holiday trade as "simply wonderful" and much difficulty was experienced in filling orders. Back orders January 1 were the largest on any similar date on record. In Milwaukee the Flanner-Hafsoos Music House, which retails the Edison exclusively, nearly doubled its 1921 business.

All Makes of Instruments in Demand

Much the same reports come from the interests representing the Vocalion, Cheney, Puritan and a great many other makes. And as the remarkable talking machine and record business was general so was the sale of merchandise by other retail stores in Milwaukee. By actual count the Boston Store of Milwaukee was entered by 89,000 people on the last business day before Christmas, and every other department store in the city as well reports the biggest business that the books of this enterprising establishment have ever shown. Music unquestionably is coming into its own in Milwaukee.

Year-end Activity Helps Inventory

Talking machine manufacturers in Milwaukee and in the interior of Wisconsin were not allowed to curtail production to the same extent as in former years after the holidays. New orders came so thick and fast that as a rule operations were interrupted only long enough to take stock and balance inventories. Bookings carried over into the new year were in excess of any previous year and even the most

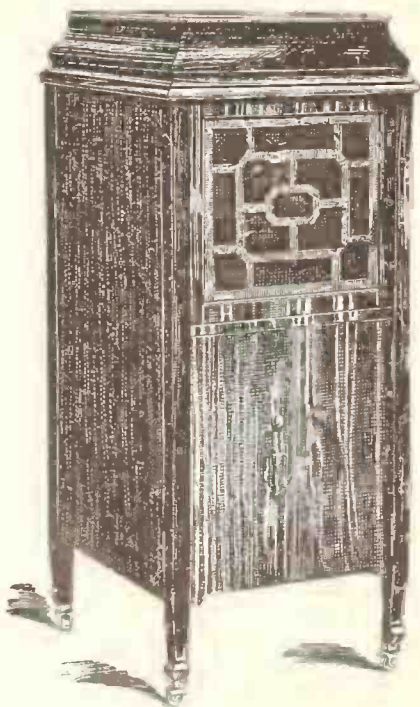

Model 11 in mahogany only

Quality Talking Machines

\$35.00
and up

THE H. LAUTER COMPANY, INDIANAPOLIS, INDIANA

Manufacturers of UPRIGHT AND CONSOLE TALKING MACHINES

conservative believe 1923 is going to be the best year in the history of the industry.

Difficult to Supply the Demand for Records

Just at present, from the retail standpoint, the demand for records is overwhelming dealers. Instruments are moving satisfactorily after the usual sharp letdown from the holiday rush. Thousands of new buyers of instruments are now flocking into the stores to get fresh supplies of records, and with record stocks consisting mainly of "broken lots" or "odds and ends," dealers are at their wits' ends to meet all demands.

Making Radio Units and Parts

George C. Trotter, Elkhart Lake, Wis., who several years ago organized the Lake Laboratories, Inc., and is manufacturing a new design of electric talking machine motor, is now engaging also in the production of radio condensers and other radio units and parts. He has incorporated the Perfection Specialties Co. for this purpose. The Lake and Perfection companies will share quarters in the plant erected by Mr. Trotter a little more than a year ago.

Victor Dealer for Postmaster

The next postmaster of Milwaukee will be a leading South Side Victor dealer unless something unforeseen occurs. Col. Peter Piasecki, late of the famous Thirty-second, or Red Arrow Division, has been nominated by President Harding, upon the recommendation of Postmaster General Work, being selected out of a large field of candidates. Col. Piasecki conducts a large music store at 441 Mitchell street. While he was in the service during the World War Mrs. Piasecki successfully conducted the business.

Increases Capital Stock

The Wilson Music Co., Oshkosh, Wis., a leading upstate Victor dealer, also maintaining a large branch house in Stevens Point, Wis., has increased its capital stock from \$50,000 to \$100,000 to keep pace with the growth of the business. Ralph E. Wilson is manager of the Oshkosh store, and George M. Farrin is in charge of the Stevens Point branch. Both branches have enjoyed a fine business.

Kaun Business Reorganized

Articles of incorporation were filed recently in behalf of the William A. Kaun Music Co., Columbia dealer. This was done by direction of the will of the late William A. Kaun, founder of the business twenty-five years ago, who died in December. The capital stock is placed at \$50,000. The principal stockholders are the widow and Paul J. Mueller, who was Mr. Kaun's faithful assistant for many years and was handsomely rewarded in the will. Mr. Mueller is active manager.

Dealers Who Are Branching Out

A Columbia department has recently been established by the Urbanek & Wattawa Co., furniture dealers at Manitowoc, Wis. A carload of Grafonolas received two weeks before Christmas was sold out before December 22.

The Crawford Music & Flower Shop, at Rhinelander, Wis., is taking occupancy this week of its new store on Davenport street. The remodeling of the Cozy Theater building provided a handsome store, twice as large as the original establishment on Brown street.

The Daly Music Co., of Wisconsin Rapids, Wis., is completing a new music store building representing an investment of approximately \$45,000.

MANY "DAILY DOZEN" SETS SOLD

Unprecedented Christmas Demand Enjoyed—Daily Broadcasting of Exercises Has Marked Effect in Boosting Demand

Robert B. Wheelan, president of Health Builders, Inc., reports that the Christmas demands for Walter Camp's "Daily Dozen" on Health Builders' record sets exceeded all expectations. Earlier in the year Mr. Wheelan based his production for the holiday trade on twice the amount of the previous year. In spite of this generous extension of production the demand for these sets was so strong that shortly before Christmas it was practically impossible to supply any more. Mr. Wheelan reports that the week before Christmas orders came in thick and fast, the last one being received at four o'clock on Saturday. One department store, which had previously placed large orders and stated in November that it was entirely fixed for the holiday season, sent in three additional substantial orders the week

before Christmas. The demand is continuing well and carrying over into the new year.

Health Builders' records of Walter Camp's "Daily Dozen" have been broadcasted for quite some time from the WHN radio broadcasting station at Ridgewood, L. I. The entire "Daily Dozen" is broadcasted three times each day—at 7 o'clock and 8 o'clock each morning and at about 10:30 each evening. It is stated that many owners of radio sets are taking advantage of this broadcasting and doing Walter Camp's "Daily Dozen" simultaneously in many homes by means of the radio. Although this plan is comparatively new on the Eastern coast Walter Camp's "Daily Dozen" has been broadcasted in California for quite some time. As Mr. Wheelan reports that business in Health Builder sets has been doubled in that State since the broadcasting began it is evident that many good prospects have developed through radio broadcasting.

The new store of Adolph Winters, Richmond, Cal., is rapidly nearing completion.

Renew the Public Interest in Your Store

with the

Safety Cinema

Without increasing your overhead or adding to your equipment for retail selling, you can greatly increase your volume of business and your profits by handling the Safety Cinema.

Transactions in this line are similar to those you now handle. Your first opportunity is in the sale of the machine. You then have made a regular customer for films, which you order for him, on a rental basis, to your own continuous and increasing profit.

The films require no investment and the details of schedule and shipment are handled by our conveniently located libraries. You handle orders only, and collect your commission. Our libraries include more than 1,200 reels—drama, comedy, travel, history, science, industry and animal life. Also feature films with Chaplin, Fairbanks, Pickford, Talmadge and other well-known stars.

Write at once for complete information, and our special agency proposition.

United Projector & Film Corp.

69 W. Mohawk St., Buffalo, N. Y.



The Safety Cinema

used by churches, schools, clubs, community centers, Y. M. C. A.'s, lodges and homes—The simplest projector on the market. Absolutely safe—Approved by National Board of Fire Underwriters — Uses Safety Standard Film.

Motor Driven. Equals theatrical models in fineness of workmanship and projection. Portable—weight 25 lbs. Retail Price

\$195.00

The Victor Home Cinema

This marvelous little machine brings the stars of movie land into the home. Gives steady projection. Uses Safety Standard film, same as the larger machines. Retail Price

\$37.50

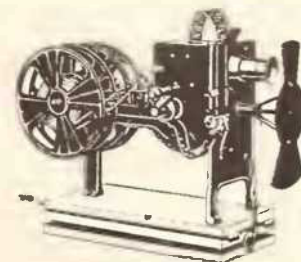

STYLUS BARS

(Any Style)

Stylus Bar and Mfg. Co.

Clague Rd.

Bay Village

OHIO

The Actual Sales Possibilities of Effective Settings for Instruments in the Period Styles

One of the most important aids to the successful retail merchandising of talking machines is unquestionably the providing of suitable settings for the display of the various models, particularly those in art and period styles—settings that will not only prove attractive to the prospect, but add directly to the appeal made by the case design of the instrument itself.

The ordinary booth of more or less elaborate

in disposing of them all at a very substantial profit.

It is natural to assume that the average retailer does not see his way clear to go to the expense of investing several hundreds, or perhaps thousands, of dollars in special decorative fittings for the display of a half dozen or so period talking machines, but it is quite possible for him in co-operation with local dealers in fine rugs, lamps and screens to borrow or rent

attractive Vocalion models. Inquiry developed the fact that Miss Mabel F. Newkirk, of the Aeolian Co. advertising department, was responsible for the change.

"What we aimed at," said Miss Newkirk to *The World*, "and frankly the suggestion came from our president, Mr. Tremaine, was to bring our visitors to a realization of the great beauty and artistic value of our upright period Vocalions by placing them in distinctive settings.



A Trio of Remarkably Effective Settings for Art Instruments at Aeolian Hall

character, or a well-furnished display room, will prove quite adequate for the display and sale of the ordinary models of instruments; but period styles demand something more—decorative surroundings, for instance, that will prove in harmony with the case designs and give to the prospective buyer some definite idea of how the instrument will look when placed in the home amid proper surroundings.

It has been found that even an attractive mirror hung back of a handsome period model will prove an aid to selling, and one retailer found that so many buyers desired the mirror in combination with the machine that he actually put in a stock of several dozen mirrors—which were more or less expensive—and succeeded

such goods for special display purposes at an expense that is insignificant in comparison with the results secured.

The effectiveness of the proper display of period models from a sales standpoint was exemplified very emphatically recently at Aeolian Hall when the holiday buying season was on. Early in December the visitor to the Vocalion department on the third floor at Aeolian Hall was struck with the great change that had been wrought in the arrangement of that department.

The main hall, with its handsome hangings, large pillars and sense of spaciousness, had been transformed by a subtle hand from an impressive though formal sales floor into a most effective setting for a number of particularly at-

tracting these models so rich in musical and decorative qualities were being overlooked to a certain extent in favor of the console model instruments.

"It was apparent that the upright models, though accepted as fine examples of cabinet making, did not display their individuality sufficiently when intermingled with regular convention upright models, whereas the console types with their distinctive form were very prominent.

"In order, therefore, to bring these upright instruments properly to visitors' attention I created a number of areas in the room by means of raised platforms, rugs, screens, lamps and banks of flowers. In these areas, as you can see, we staged our period model instruments, both singly and in pairs. For example, in one corner we have two Jacobean instruments, one upright and one console. In another space we show two beautiful Florentine instruments, etc. It is our purpose to bring to visitors' attention the fact that we are prepared to supply him or her with an instrument in any of the popular periods and in either form.

"It is our experience that the public are very apt to base their valuation of any goods a dealer has to sell upon the dealer's own apparent estimate of it. By segregating these instruments and staging them, as it were, we draw attention to their charming appearance and the fact that so far from being simply decorated conventional phonographs they are really a very modern development in phonograph cases. We are highly pleased with the result of our efforts because we have not only succeeded in adding greatly to the attractiveness of our salons, but the sales sheets also show very flattering results."

The accompanying illustrations give some general idea of the arrangement of the Vocalion salons under Miss Newkirk's direction. At the left is shown an effective combination of Chippendale and Chinese decorative influences, a rich blue Chinese rug being used as a base for a beautiful pair of Chippendale Period Vocalions. The only white light in the room was thrown upon this group, tempered by a tall, blue-shaded torchere.

The central group displays two sturdy walnut models in the Jacobean period set off by a fine

Saxophones You'll Be Proud to Sell

And Priced So You Can Sell Them!

GRETSCH-AMERICAN SAXOPHONES

Full Pearl Key Equipped

If you've been thinking that you can't handle Saxophones at a profit, just write for the wholesale prices of GRETSCH-American Saxophones!

The instruments themselves are the finest we've ever turned out. Every one perfect in intonation and mechanism—each one adjusted to perfection before it leaves our plant.

Your choice of all models from the little straight C-Soprano up to the giant B-b Bass. Each model can be had in any standard finish.

And don't forget our slogan! TWENTY-FOUR-HOUR SERVICE ON YOUR SAXOPHONE ORDERS.

*Write us on your business letterhead
and let us tell you more about our
attractive Saxophone proposition*

The FRED. GRETSCH MFG. CO.

Musical Instrument Makers Since 1883

60 BROADWAY, BROOKLYN, N. Y.

Someone wants to telephone. Up the street is a pay station sign. Though too far away to read, the sign and its message are instantly recognized. Same with the Columbia Exterior Metal Record Sign. \$5.00 at your Columbia Branch.

Columbia Graphophone Co.
NEW YORK



Moussoul rug, a hand-painted leather screen and parchment shaded lamp in rich red and amber colorings. An effective foil is the group beyond designed for a conventional drawing room in rose, gold and old ivory.

At the right is shown how a glowing crimson rug and softly ambered lights brought out most effectively the rich casewoods and polychrome ornamentation of these exquisite Italian Renaissance cabinets.

The entire arrangement was particularly interesting in that it served to demonstrate a plan for the effective and artistic display of period models that is within the scope of any retailer who has a sufficient interest in the matter to gather together and arrange the necessary properties.

HELPS CLOSE SCHOOL SALES

MANKATO, KAN., January 7.—Where many a merchant might stop trying to sell, Mrs. O. H. Kinman, local Columbia dealer, lends a hand to help clinch the sale. Mrs. Kinman has been particularly successful in assisting the school



Mrs. O. H. Kinman at Work

authorities to devise plans and methods whereby they could secure the necessary funds to purchase a Columbia Grafonola and a supply of Columbia records. These methods have included school fairs, basket parties, etc., but invariably Mrs. Kinman is "on deck" personally to help put the sale across. Her ideas have proved successful, for she has sold fifty-six Grafonolas to schools in one year.

R. P. Griffin, associated for some time past with the Goodhart-Tompkins Co., Atlanta, Ga., is now connected with the Phillips & Crew Piano Co. Victrola department.

No. 35217. Basket filled with flowers, each \$0.75, per dozen \$7.50.



Our Spring Catalogue No. 35 illustrated in colors of Artificial Flowers, Plants, Trees, Vines, Baskets, etc., mailed free for the asking.

Frank Netschert, Inc.
61 Barclay St.
New York, N. Y.

CLEVER PLAN BOOSTS RECORD SALES

Paul-Gale-Greenwood Store, Norfolk, Va., Secures Co-operation of Local Dance Palace to Stage "Victor Record Night"—Increased Interest in Dance Releases Has Resulted

"One night each month will be 'Victor Record Night' at the Palais de Danse!"

This statement in an advertisement in Norfolk, Va., newspapers marked the arrival by David Paul, manager of the Victor department of the Paul-Gale-Greenwood store, at a satisfactory solution to a problem that puzzles the average talking machine and record dealer.

Getting the new records as they are released by their makers to the attention of owners of talking machines was the problem. So many machine owners were found by Mr. Paul to be satisfied, apparently, with such selections as their record cabinets contained.

In order to boost sales of dance records Mr. Paul conceived a plan for attracting public attention to the latest releases through the medium of an orchestra, reproducing as faithfully as possible the music on the records.

Introduction of new records by orchestral reproduction was the idea. To carry it into operation he conferred with the director of the Palais de Danse, a popular and attractive public dancing resort, conducted on a high plane, and an agreement was reached to share the cost of advertising and other incidental expenses. Then announcement was made of the Victor record dance—a novelty for local dance-goers.

With the well-known Victor dog much in evidence and records and release announcements among decorations, the new feature dance was put on, with a program of music played by the Paul Whiteman Orchestra for Victor records and reproduced by the Harmony Super-Six Jazzers, of Norfolk. This reproduction afforded a volume of music impossible by mechanical amplification without distortion. The dancers' enjoyment of the orchestral reproduction of the Whiteman records in many cases created a desire to own some of the records played and visits to the store to rehear the music and purchase records followed.

Another feature of the plan is the giving by the Palais de Danse management of an order, redeemable at the Paul-Gale-Greenwood store, for a record to each of fifty dance attendants.

"Following Victor record nights many new inquirers and buyers come to our store," said Mr. Paul. "They are enthusiastic over Victor dance music. The idea is a success and the cost is comparatively small. The dance salon management is glad to pay for the records given away, when we share advertising and incidental costs, because the novelty of the idea brings new patrons to the place."

E. J. Borton, educational director of the J. Lee Nicholson Institute of Cost Accounting, Chicago, has written on "Production Costs in the Manufacture of Phonograph Records" for the National Association of Cost Accountants.

SPECIAL VICTOR RECORD RELEASES

One German and Three Jewish Records From March Supplement to Be Placed on Sale on January 17—Bear Interesting Numbers

The Victor Talking Machine Co. has announced a special release of one German and three Jewish records which will appear in the regular March record supplement, but will be placed on sale on January 17.

The German record by Max Bloch is entitled "Morgenglocken" and represents a German waltz song version of "Three o'Clock in the Morning." On the other side is a recording of "Sonja," also by Bloch. Both sides of one of the Jewish records are given over to song hits of the "Poor Man," a successful operetta playing at one of the Jewish theatres in New York. The second record bears songs from "Dance, Song and Wine," and the third song from "Love's Torment" and "Wise Women," all of them popular Jewish operettas.

NEW YORK FIRM CHARTERED

The Independent Recording Laboratory, New York City, was recently incorporated under the laws of New York State, with a capital of \$5,000, for the manufacture of musical instruments. Incorporators are A. J. Baum, B. A. McGuire and B. Strauss.

Recording for the Phonograph Trade

The best equipped and efficient—low cost—laboratory in the industry.

Our success in recording for some prominent makes of records assures you a high-class product.

A visit or telephone call will give you the details.

Let us solve your technical problems.

A. J. BAUM, Manager
ARTHUR BERGH, Musical Director
FRED OCHS, Recorder

INDEPENDENT RECORDING LABORATORY, Inc.

102-104 West 38th Street New York
Phone: Fitzroy 5385

Announcing a New Complete Line LONG CONSOLES

Due to heavy demand, necessitating large cuttings, we have been able to reduce our manufacturing costs. We pass this saving to our customers—more than 10 per cent below former prices:

Please note that while Consoles 601, 602, 603, 608 and 610 are regularly fitted to take care of Victrola VI, these same cabinets can be fitted to take care of Victrola IV, and, when taking the reduction in price of Consoles into consideration, it enables the dealer to sell an up-to-the-minute standard outfit at a very moderate price.

Long Consoles are covered by basic patents and infringements will be prosecuted.

Long Consoles are distinctive in design and have the divided top.

Long Cabinets are regarded by the trade as the Standard of Quality.

Deliveries can be made at once.

Made in dark red mahogany only.

Order now for Fall and Holiday requirements.

Write to-day for catalog of full line.

All of the Long Consoles illustrated on this page, except Style 606, are also ideally adapted for use with the Columbia Grafonola A-2.



Style 601
Price \$27.00



Style 606
For Victrola IV only
\$20.00

Specifications:

Made in dark red mahogany only.
One piece top, 19½ inches long;
34 inches high; 21½ inches deep.



Style 603
Price \$29.00

New LONG Radio and Talking Machine Cabinet



Style 608
Price \$30.00



Style 650
Price \$33.00



Style 610
Price \$28.00

Specifications for all models except 606. Made in dark mahogany only. Two-piece top, 36 inches long, 34 inches high and 22 inches deep.

LONG combination Radio and talking machine cabinet for Victrola VI. Radio chamber will accommodate receiving set 7 inches or less in height; room available for dry batteries. Head-sets or loud speaker may be attached to radio terminals. Cabinet shown equipped with Westinghouse Aeriola, Sr., and Baldwin loud speaker.

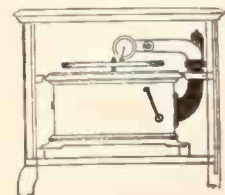

The Geo. A. Long Cabinet Company
HANOVER, PA.

AKRON, O.

*Resumption of Rubber Industry
Augurs Well for Trade—A. E.
Jones Opens Store—Brisk Trade*

AKRON, O., January 6.—Akron music dealers have every reason to believe that the new year which has just started will not only continue the better business which has been experienced in recent months but will find the retail music situation showing constant improvement because of the better industrial conditions promised on every hand.

The rubber industry, which has been the basis of all business in this district, promises to enter the best year in its history and will employ several thousand men during the next few months.

Substantial gains in business in November and December have been reported by the more aggressive merchants and they are optimistic now as to what business is in store for them in early 1923. In some instances gains are better than 80 per cent compared to business a year ago. Heavy advertising in local papers has stimulated sales to a great extent. Fully 20 per cent less people are asking for credit in buying talking machines now.

There is still a noticeable shortage in some models of the better makes of machines, dealers here said this week.

Jones Opens New Store

Albert E. Jones, for many years head of the music department of the William R. Zollinger & Sons Co., Canton, and more recently manager of the piano department of the George S. Dales Co., Akron, has opened a music store in North Hill, Akron, and is featuring the Columbia Grafonolas and the Jesse French line of pianos. Later he plans to add musical merchandise and other talking machine lines and records. Mr. Jones is one of the oldest talk-

ing machine salesmen in Eastern Ohio and is well-known to the industry.

Starr Machines Moving Well

Although there are no figures available Starr phonograph sales during the month of December topped those of previous months of 1922 by a big margin. C. C. Currie, manager of the Superior Music Parlors, South Howard street, which formerly was the Starr Piano Co., told a representative of The World this week that Starr machines moved very satisfactorily in December and that the most popular of all models was the new console type. This store is showing the new library table model which is the most expensive number turned out by the Starr factory. Mr. Currie also reported that Gennett records are moving better than at any other time this year and a gain of approximately 20 per cent is noted since November 15.

Cheney Demand Is Good

Talking machine sales in December were double those for the same month a year ago with the talking machine department of the M. O'Neil Co., Akron's largest department store, according to Miss Elsie Baer. At this store the Cheney machine was much in demand, the bulk of the business being confined to the higher priced models. Miss Baer predicts a busy year for the talking machine industry, and says that what business will come now will be of a much more substantial nature than that of the past two years, the larger part of which has been on the payment basis.

Scoyoc Co. Enjoys Brisk Trade

At the store of the F. W. Van Scoyoc Piano Co., South Main street, which has been in existence less than a year, the talking machine department in December topped all records for volume of business. Mr. Van Scoyoc said this week that practically every salable machine on the floor Christmas week was sold and that perhaps additional business could have been done the final day had the store had a big stock of machines on hand. This

store has given up the idea temporarily of installing a record department in the basement and will continue for the time being to specialize in well-known makes of pianos and the Stradivara line of talking machines.

Dales Co. Christmas Sales Heavy

Christmas business at the store of the George S. Dales Co. was the heaviest in recent years. Demand during the early part of December was for the medium priced machines, but the last week brought customers to the store who sought the best make machines in stock. This store reports that between twenty and twenty-five machines were moved from the sales floor the last day before Christmas.

To make room for jewelry display the Main street record booth, a feature inaugurated some months ago by this store, has been discontinued and all record sales will be confined to the talking machine section in the future.

The piano department has been moved to the third floor and now the entire second floor has been given over to the display and sale of the Victor and Cheney machines. It is the largest talking machine section in the city of Akron and is possibly the most handsomely appointed of any in this section of the State.

The Dales Co. announces it has taken on the Seabrook Phonograph Corp.'s line of radio talking machines and already some numbers are being displayed on the sales floor.

Victor Business Phenomenal

Earl G. Poling, of the Windsor Poling Co., said this week in discussing the Christmas business: "And the improvement in the trade has only just commenced, and I predict a busy Spring for the industry." Mr. Poling said that educational propaganda is beginning to tell and that results are in evidence every day. Reinald Werrenrath came to Akron for a concert New Year's night under the auspices of the Windsor Poling Co. and, according to Mr. Poling, the advance seat sales exceeded all expectations—the house being entirely sold out days previous to the concert.

NEW YEAR'S GREETINGS

We are glad of this opportunity to extend to our Patrons whose Friendly Relations have made possible bigger and better things, our Most Cordial Greetings and Sincere Thanks.

May the New Year Bring You a Full Realization of Your Best Hopes.

DUO-TONE COMPANY, INCORPORATED

Sole Manufacturers of De Luxe Needles
ANSONIA, CONN.



Full Tone

DON'T FORGET THESE FACTS
Perfect Reproduction of Tone No Scratchy Surface Noise
PLAYS 100-200 RECORDS



Medium Tone

Three for 30 cents (40 cents in Canada)
LIBERAL TRADE DISCOUNTS

Another New Jewel Creation

The Jewel Tone Arm No. 4

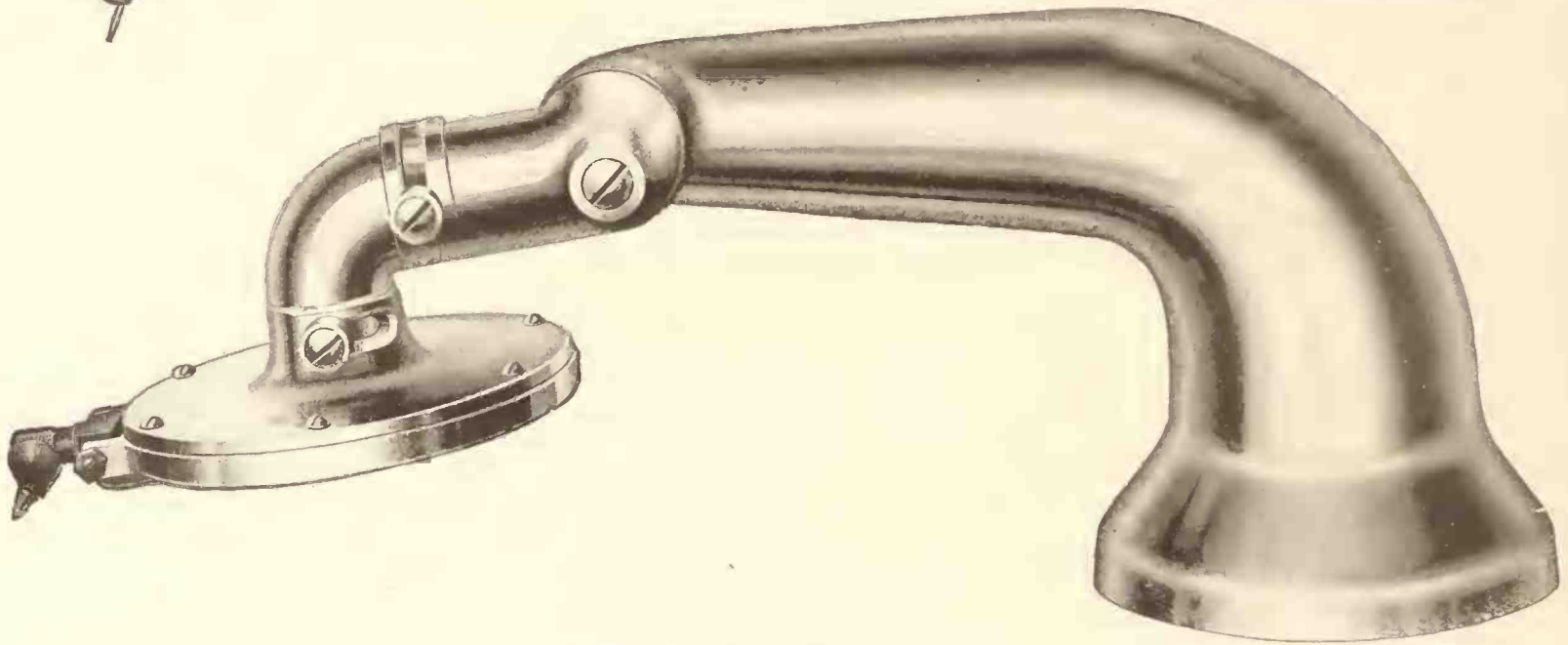
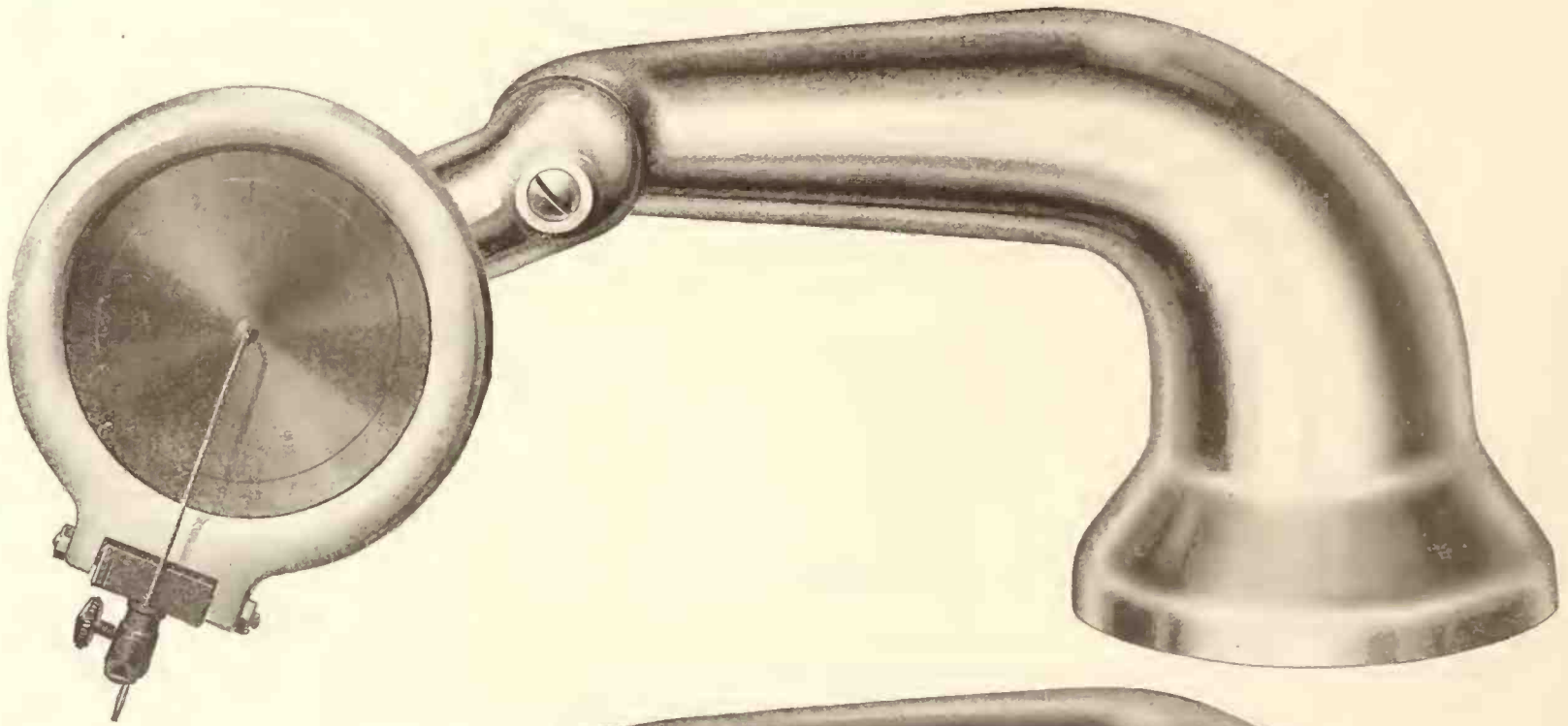

Exclusive Features

Plays Edison and Pathe Records in actual Edison position and with a fibre needle.

Made in 8½", 9½", 10½".

When thrown back on tone arm in Edison position, the reproducer lies flat, so dome cannot touch it when closed.

Finished in nickel or gold plate.

Note: Handsome Bell Base without flange showing.

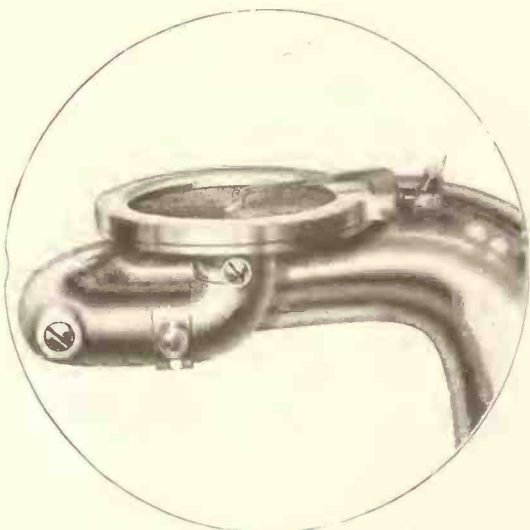

Shows reproducer thrown back on tone arm in Edison position.



Equipped with or without Mute; Mica or Nom-y-Ka Diaphragm.



160 Whiting Street

CHICAGO, U. S. A.

Jewel Tone Arm DeLuxe No 5

Adjustable Spring Tension Non-Throw-Back Tone Arm

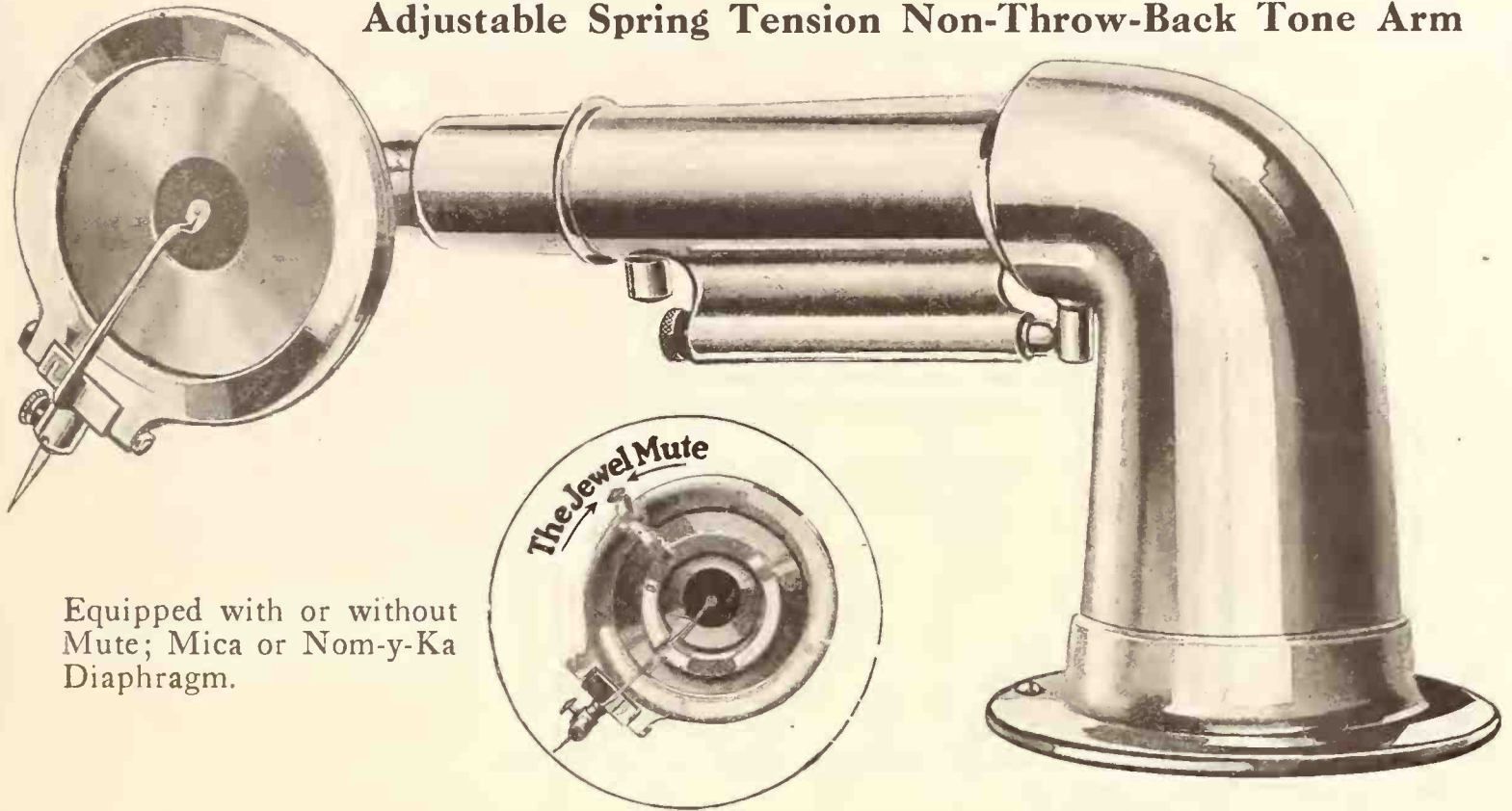

Equipped with or without Mute; Mica or Nom-y-Ka Diaphragm.

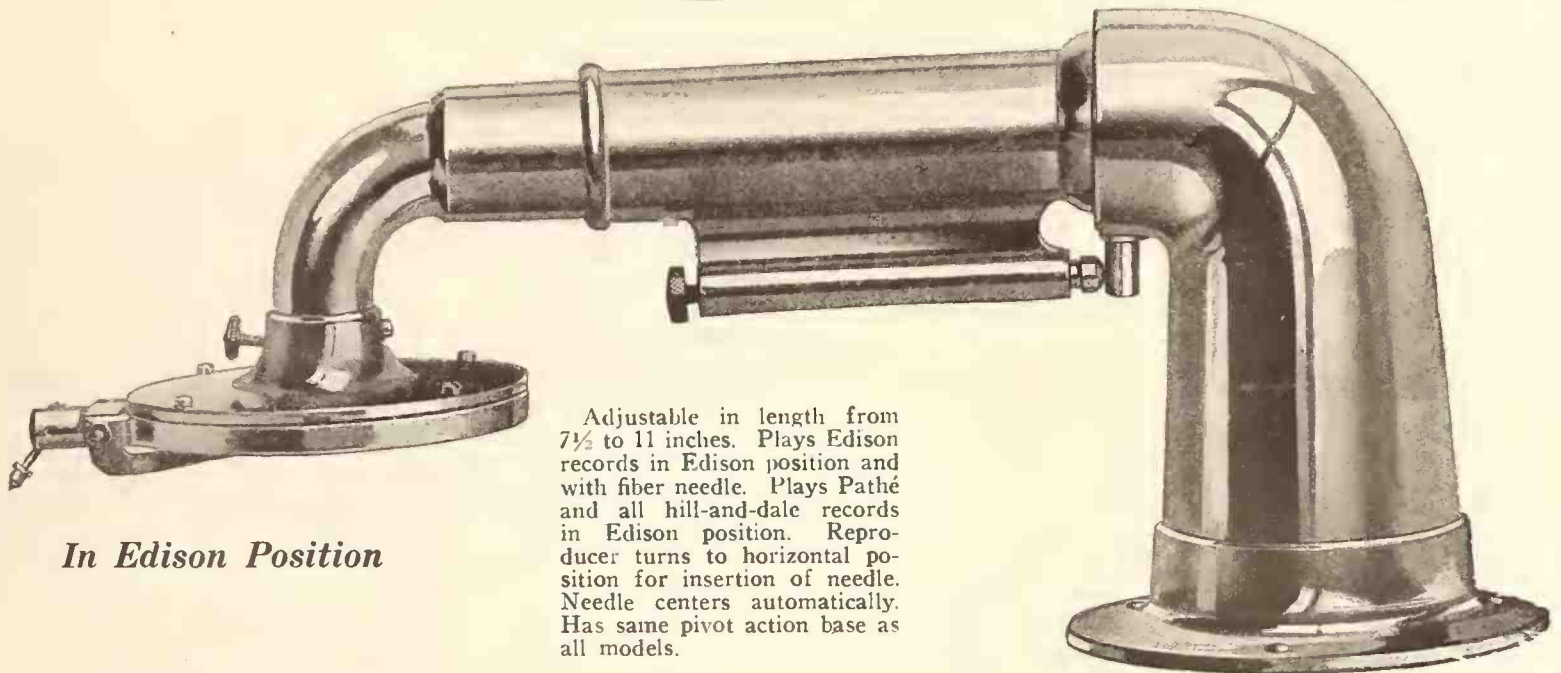

In Edison Position

Adjustable in length from 7½ to 11 inches. Plays Edison records in Edison position and with fiber needle. Plays Pathé and all hill-and-dale records in Edison position. Reproducer turns to horizontal position for insertion of needle. Needle centers automatically. Has same pivot action base as all models.

This also plays Edison and Pathe Records in the exact Edison position, and like all the JEWEL Tone Arms, will play Edison Records with either "Saffo" point or Fibre needles

It throws the least weight on a record of any tone arm ever made—which adds greatly to the life of all records—and permits reproducer to pick music from the record instead of scraping it out.

Yet, by adjusting tension thumb-screw on the lower side of tone arm which controls a counter-balanced plunger, the whole weight of tone arm and reproducer can be obtained when necessary.

Furnished with or without Mute, with Mica or NOM-Y-KA Diaphragms.

Note absence of any collar or ball retainer to hold ball in neck of base. This avoids all chance of rattle and lost motion in tone arm that causes blast and false tones.

Ball connection is positively airtight, with pivot action giving perfect lateral and horizontal movement. Is also held in rigid position by means of a tension screw and plunger.

Diameter of opening at base, 2 inches.

Height of dome, 4½ inches.

Finished in fine nickel or gold plate.

160 Whiting Street



Chicago, Ill., U. S. A.



Ar - a - by, I'll soon be there, — My land, it gave me life and love, —

FLOWER OF ARABY

AN ARABIAN LOVE SONG

"You can't go wrong
With any FEIST song"



"HYLITE DISTRIBUTOR" MAKES BOW

Henry Hyman & Co., Inc., New York, Manufacturers of Radio Receiving Sets, Issue First Number of New House Organ,

The first number of the "Hylite Distributor," the new house organ just issued by Henry Hyman & Co., Inc., New York, manufacturers of radio receiving sets, was sent out to their large clientele this month and was received with keen enthusiasm. The first issue features strongly the complete line of "Bestone" sets, which, in a short time, have been so successfully distributed to dealers throughout the country and which have been giving excellent results to purchasers. One section of this first issue is devoted to the activities of the company's sales representatives, who are scattered in all sections of the country, each being remembered with some short and pointed paragraph pertinent to some notable accomplishment in his particular territory. The company takes this opportunity to impress on the trade the co-operation they are giving to them by way of general publicity to create a demand for their product by showing in a full-page display the different mediums which are being used for advertising. This display is in the form of a composite plate on which the covers of trade papers and other advertising mediums used are attractively shown.

The frontispiece contains a message from the president of the company in which he voices his thanks for the splendid co-operation which has prevailed throughout the year.

It is the plan of the company to issue this interesting publication at regular intervals during the year to serve as an outlet for merchandising ideas and to give the trade a general idea of the activities of the company, which it is expected will establish a closer contact that is bound to have its effect on the sales of "Bestone" sets everywhere. W. A. Bresalier, advertising manager, is responsible for this new activity of the company and is receiving congratulations on the appearance of the first number.

An attractive music store has been opened at S. W. Narbonne avenue, Lomita, Cal., by J. R. Weaver. He plans to have it most attractively equipped.

Recording Wax

Wax and Novelty Co.

(F. W. MATTHEWS)

167 and 169 Bloomfield Ave.

Phone Bloomfield 5149 BLOOMFIELD, N. J

BRILLIANTONE IN LARGER HOME

Ever-growing Business of Brilliantone Steel Needle Co. Results in Removal Into More Spacious and Convenient Quarters

The Brilliantone Steel Needle Co., producer of the well-known Brilliantone steel needle and selling agent for the W. H. Bagshaw Co., of Lowell, Mass., occupied new offices at 370 Seventh avenue beginning with the first of the year. This is the second move made necessary by the constantly expanding business of the company. Several years ago, when the company was formed, offices were opened in the Marbridge Building, which in a very short space of time were found inadequate. Accordingly, increased space was secured at 347 Fifth avenue, which in turn has been outgrown. The new offices at 370 Seventh avenue, located in the important business zone surrounding the Pennsylvania Terminal, provide greatly increased space and facilities and make possible the housing under one roof, in fact, on one floor, all of the departments of the organization. For many years the Brilliantone Steel Needle Co. has made use of outside storage space. The new quarters will provide for storage space as well and thus greatly facilitate service and delivery for the coming year. The new offices are very attractively and efficiently laid out and occupancy was made without loss of time in the carrying on of the business.

Both B. R. Foster, president of the company, and H. W. Acton, secretary, look forward to 1923 as the banner year in the history of the organization.

Sydney Risser, well known throughout the metropolitan territory as sales representative of the Brilliantone Co., will add to his territory Philadelphia, Baltimore and Washington, formerly covered by Louis Unger when connected with the Brilliantone Co. before he became general manager of Reflexo Products, Inc.

WILLIAM PHILLIPS CORP. MOVES

Secures Larger Quarters in Same Building—J. A. Brown in Charge of Engineering and Inspection—Optimistic Over Future

The William Phillips Phono Parts Corp. occupied new offices in the same building, 145 West Forty-fifth street, New York City, beginning with the first of the year. These new offices, situated on the twelfth floor, have been attractively laid out and furnished. William Phillips, president of the company, reports that business is lined up exceedingly well for the coming year, which he expects will be the biggest year in the history of the organization. Mr. Phillips has also announced that J. A. Brown, an authority on tone and sound-box construction and also the inventor of the Supreme octagon sound box No. 5, has been placed in charge of engineering and inspection at the Phillips factory.

NEW VICTOR NUMERICAL CATALOG

Volume Just Issued for 1923 Lists All Records Prior to January, 1923, Supplement

The Victor Talking Machine Co. has just issued a new numerical catalog of Victor records for use during the year 1923. The catalog is similar in all general details to those issued during previous years which have proven so valuable to Victor dealers, and includes all records announced prior to the January, 1923, supplement.

Goebel & Newhouse, music dealers of Chico, Cal., suffered considerable damage in a recent fire.



Should be on Every



Phonograph and Player Piano

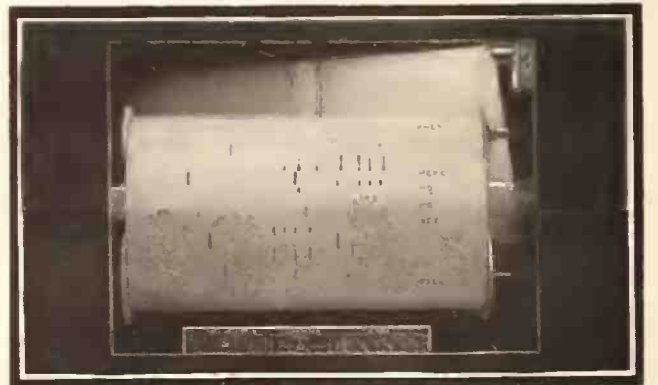

Beautifully finished in Nickel or Gold

It applies perfectly to every phonograph and player piano, no instrument is complete without it.

For phonographs this light makes cumbersome operations easy and simple in darkest corners where phonographs are usually placed. It prevents scratching of records and makes setting of automatic stop positive and simple.

For player pianos it is indispensable, gives an abundance of illumination for singing or inserting music rolls.

Easily and quickly attached, comes complete ready for use, no electricity or wiring necessary.

RECORD FLASHERS last indefinitely and are fully guaranteed. Batteries last from 6 to 12 months in service. Renewals can be had at 75 cents.

Prices { Nickel Plated with Battery - - \$3.00
Gold " " " " - - 3.75

Special Discounts to Dealers and Manufacturers
Write for descriptive circular

Standard Accessory Corporation

Sole Manufacturers and Patentees

1015 Third St.

Milwaukee, Wis.

For Beauty, For Tone, For Price



Strand Model 23 Hepplewhite Period Console.
Walnut or Brown Mahogany
Lists at \$115



Strand Model 24 French Chippendale Period
Console, Walnut or Brown Mahogany
Lists at \$175

**Two New Strands.
Size Them Up.
Note the Prices.
Ask the Discounts.
Get the Business.**

Built according to the Strand policy of high quality and correct design; offered to the dealer in accordance with the Strand policy of low list and long discounts. Now in production; prompt, safe deliveries assured by ample output and a trouble-proof shipping system.

"It's the Dealer's Turn Now"
(just as we said all last year)

*"The Man Who Does the Selling
is Entitled to a Real Profit"*
(just as we said all last year)

Ask for Descriptions of these
STRAND CONSOLES

- Model 8 Queen Anne \$125
- Model 1 Louis XV 150
- Model 2 Italian Renaissance 175
- Model 4 Louis XVI 200
- Model 16 Renaissance 250

MAXIMUM DISCOUNTS

Strand Offers the Only Complete Line of True-to-Period Consoles

These direct Strand representatives are ready to serve you

RICHARD H. ARNAULT, 93 Madison Avenue, New York City
ARTOPHONE CORPORATION, 1103 Olive Street, St. Louis, Mo.
ARTOPHONE CORPORATION, 317 Kansas City Life Bldg., Kansas City, Mo.
W. O. CARDELL, Tulsa, Okla.
CONSOLIDATED TALKING MACHINE CO., 227 W. Washington Street, Chicago, Ill.
R. L. CHILVERS, 903 New Birks Bldg., Montreal, Que.

OTIS C. DORIAN, 110 Church Street, Toronto, Ont.
A. C. ERISMAN, 174 Tremont Street, Boston, Mass.
WALTER L. ECKHARDT, 624 Market Street, Philadelphia, Pa.
W. S. GRAY, 912 Market Street, San Francisco, Cal.
J. J. GRIMSEY, 926 Midway Place, Los Angeles, Cal.
L. D. HEATER, 337 Ankeny Street, Portland, Ore.

H. J. IVEY, Box 235, Dallas, Texas
IROQUOIS SALES CORP., 210 Franklin Street, Buffalo, N. Y.
R. J. JAMIESON, 27 Taylor Arcade, Cleveland, O.
MERVIN E. LYLE, 214 Peachtree Arcade, Atlanta, Ga.
RICKEN, SEEGER & WIRTS, Globe Bldg., Detroit, Mich.
SILZER BROS., 1019 Walnut Street, Des Moines, Ia.
STERLING ROLL & RECORD CO., 137 W. 4th Street, Cincinnati, O.

MANUFACTURERS PHONOGRAPH COMPANY, INC.
95 Madison Avenue, New York Geo. W. Lyle, President

C. R. JOHNSTONE
VICE-PRES., GEN. MGR.

THE BELL RECORDING CORP.,

BEST RECORDING
EXPERIENCED SPECIALISTS
LOUD AND CLEAR
LAST WORD IN QUALITY

Associated With National Metals Depositing Corporation

9 East 47th Street, New York City

We Specialize in Private Recording

and

General Recording for the Phonograph Trade

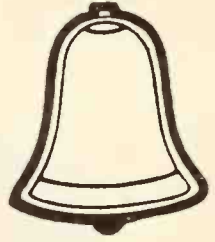

SALT LAKE CITY

Crowds Thronged Music Stores for Holiday Gifts—An Unusual Window Display—New Daynes-Beebe Music Co. Branch—Other News

SALT LAKE CITY, UTAH, January 8.—The local music houses did a wonderful business during the holiday season just closed. There was not a single exception and your correspondent experienced real pleasure in making the rounds this month. Manager Berry of the talking machine department, Glen Bros.-Roberts Piano Co., said he had as many as ten persons waiting at a time in his department. Machines running in price from \$100 to \$150 seemed to be most favored and competition was unusually keen—customers would go from one store to another before finally deciding to buy. The stores were all open till 9 p. m. during the week before Christmas Day, but on Saturday night some of them had to keep open till nearly midnight so that patrons could be taken care of. It is interesting to note that jewelers, also, did a wonderful business this year.

The Consolidated Music Co.'s Christmas window, trimmed by Dean Daynes, brother of Manager Royal W. Daynes, attracted considerable attention. The most striking thing about it was a snowstorm, a very realistic affair, which could be seen through a comfortable middle class home in which various musical instruments, such as pianos and talking machines, were in their places. A fire was burning in the English fireplace near which Santa Claus was standing, trying to decide which stocking to fill first. Mr. Daynes said the snowstorm presented a problem at first and was eventually solved by having a pipe organ blow the tiny pieces of tissue paper which were cut to resemble snow.

The Daynes-Beebe Music Co. will have opened its new branch in Hollywood, Cal., before these lines appear in print. Col. Joseph J. Daynes, president of the company, told your correspondent that they would start with 2,000 square feet of floor space and would carry for the time being pianos, players and phonographs. The store is in the heart of Hollywood's shopping center and a long lease has been taken. It will be under the management of A. T. Christensen, an old employe of the firm and until a short time since its sales manager.

Miss Susie Pearson, eight years with the Utah Music Co., East First South street, has joined O'Loughlin's phonograph store on Main street.

A number of Mormon or Latter-day Saint girls belonging to the Girls' Service League of the Granite State collected 450 phonograph records and almost 700 pieces of sheet music during the Christmas holidays for presentation to a number of institutions including the State prison. Their efforts are to be continued in order that other institutions may be helped.

The Daynes-Beebe Music Co. had a fine window illustrating a village on Christmas Eve. It was the work of Todd Taylor.

The Glen Bros.-Roberts Piano Co. are receiving the congratulations of friends on the success of S. A. Palmer's window, "Three o'Clock in the Morning," which received first prize in the recent national contest.

Secretary Fred Beesley, Sr., of the Utah Association of Music Industries, is still at the

Latter-day Saints' Hospital where he is likely to remain for a few more weeks at least. He underwent another serious operation a day or two ago.

The Dinwoody Furniture Co. is giving up its phonograph department.

PATHE EXHIBIT AT RADIO SHOW

Radio Parts Made by the Pathé Phonograph & Radio Corp. Attract Attention at Radio Show in Grand Central Palace in New York

The Pathé Phonograph & Radio Corp., Brooklyn, N. Y., was represented at the radio show held at the Grand Central Palace, New York City, by an interesting exhibit that attracted much attention. The Pathé loud speaker in conical form, somewhat similar to the Actuelle talking machine reproducer, created considerable comment through its marked difference from other loud speakers exhibited. Other radio parts produced by the Pathé Co. were shown as well. These parts included a three-stage amplifier and a Pathé variometer, vario coupler and dial. It was pointed out that the three latter parts were all molded of Pathol, a new development of the Pathé Phonograph & Radio Corp. The talking machine division of the company was represented by a Pathé Actuelle phonograph.

OGDEN CABINET CO. VERY BUSY

LYNCHBURG, VA., January 2.—J. B. Ogden, president of the Ogden Sectional Cabinet Co., manufacturer of sectional record cabinets, You-nit tables and wareroom equipment, reports that the Ogden plant has been extremely busy day and night and that every effort is being made to keep up with orders for cabinets and wareroom equipment which are steadily reaching the company from all sections of the country.

NATIONAL METALS DEPOSITING CORPORATION

FACTORY
34 East Sidney Ave., Mt. Vernon, N.Y.
Telephone: Oakwood 8845

MOUNT VERNON — NEW YORK
MANUFACTURERS OF

LABORATORY
9 East 47th St., New York City
Tel. Vanderbilt 4153



WE DEPOSIT THE
FINEST COPPER
IN THE WORLD

FOR YOUR CONVENIENCE
DELIVER RECORDED WAX
TO OUR LABORATORY

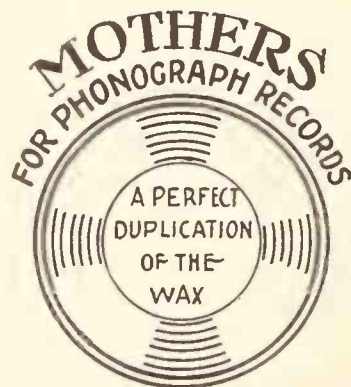

OUR
IMPROVEMENT
ALL STAMPERS
HAVE
HIGHLY POLISHED
MACHINED BACKS

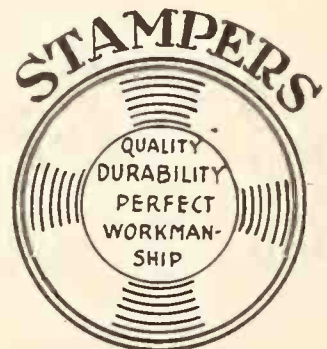

Imported Recordings by
MAREK WEBER
AND HIS ORCHESTRA
are now available

By special arrangement with the leading record manufacturers of Europe, we are able to offer the American public a repertoire of rare record importations which features the foremost artists of Europe.

The superb voices of world-famous operatic stars, the genius of internationally known musical organizations and orchestras, and the musical celebrities of every country in Europe are now available on these records which are pressed in the Okeh factories and released under the ODEON and FONOTIPIA labels.

For the first time, the American public is hearing the music of Europe perfectly interpreted by native musicians who are supreme in their individual fields.

Take, for example, Marek Weber and His Orchestra. Their playing has won for them the enviable reputation of being Europe's foremost interpreters of the light classics.

For decidedly the same reason, the imported recordings of Marek Weber and His Orchestra, so delightfully different in orchestration, are rapidly gaining the favor and praise of those in America who know and appreciate music of the better kind.



MAREK WEBER

Two of the popular imported records by
MAREK WEBER AND HIS ORCHESTRA

- | | | | |
|-----------------------|---|---|-----------|
| 3018 12 in. \$1.25 | } | VOICES OF SPRING (Voce di Primavera) (Frühlingsstimmen) (Johann Strauss) Recorded in Europe | Orchestra |
| | | FLATTERGEISTER (Johann Strauss) Recorded in Europe | Orchestra |
| 3017 12 in. \$1.25 | } | BLUE DANUBE WALTZ (Johann Strauss) Recorded in Europe | Waltz |
| | | SOUTHERN ROSES WALTZ (Johann Strauss) Recorded in Europe | Waltz |

Okeh Records
The Records of Quality



General Phonograph Corporation
OTTO HEINEMAN, President
25 W. 45th St. New York

THE 1923 OUTLOOK FROM THE BRUNSWICK STANDPOINT

A. J. Kendrick, General Sales Manager, Phonograph Division, Brunswick-Balke-Collender Co., Tells of Some of the Problems Overcome and of the Plans for the New Year

CHICAGO, ILL., January 5.—A. J. Kendrick, general sales manager of the phonograph division of the Brunswick-Balke-Collender Co., in an interview with *The World* to-day expressed himself as being enthusiastic over the progress made by his company and the trade in general during the past year and was distinctly optimistic regarding the future in view of the plans that are under way for forwarding the Brunswick interests during 1923. In this connection he said:

"Economists tell us that there are four consecutive cycles through which the business world passes in a certain number of years. They call them the periods of inflation, deflation, adjustment and improvement.

"While other business was undergoing the severe strains of deflation and adjustment the Brunswick-Balke-Collender Co., it is interesting to note, was reaping a good harvest. It had sown the seeds of good-will and progress in the period of inflation during the war. The result was a truly remarkable growth while other businesses were suffering a loss.

"It is not strange when one considers that the Brunswick-Balke-Collender Co. was, so to speak, plowing much new uncovered ground—not depending entirely on the established channels.

"The year 1923 will mark the entrance of the Brunswick-Balke-Collender Co. into a program of expansion which will bring still greater profits to our partner—the Brunswick dealer. He will receive, in 1923, even still closer co-operation from our sales organization, which is being enlarged and strengthened in all parts of the country.

"It is the Brunswick policy that the dealer must succeed first, so our salesmen will work more intensively than ever with, and for, the Brunswick with new and improved sales plans.

"We are now putting into operation the new centralized warehouse plan which will make larger and more elastic stocks available to Brunswick dealers. Brunswick production plans have also been greatly expanded, involving the addition of much new equipment in both phonographs and records, so that the word 'shortage' will no longer exist.

"The Brunswick advertising appropriation for 1923 has been greatly enlarged and plans to be announced later will meet, we are sure, with unanimous approval of all Brunswick dealers.

"The phonograph industry should note with particular interest that the farmer has again become a potent buying factor to be seriously considered. Mr. Farmer has approximately two

billion more dollars to spend during the next six months than he had at this time one year ago. One-third of our total population consists of the farmer class, so Mr. Farmer again becomes the man to whom phonograph dealers should turn for increased sales during 1923.

"Mr. Farmer must be sold, however. The dealer who, if necessary, locks up his store, puts a phonograph in his car, rides out to the farm and talks to the 'old man and missus' will sell the farmer.

"The general public, including Mr. Farmer, has changed its name from Mr. and Mrs. Spendthrift to Mr. and Mrs. Thrifty. The public now carefully seeks one hundred cents value on every one dollar spent. Brunswick dealers will be particularly fortunate during 1923 in being able to cater to Mr. and Mrs. Thrifty with a complete line of Brunswick consoles as well as uprights and art styles whose various prices fit every size of pocketbook and bank account."

J. J. DAVIN ASSUMES NEW DUTIES

New Sales Manager of Ormes, Inc., Welcomed by Local Trade—Again Active in Affairs of Talking Machine Men, Inc., of New York

James J. Davin, whose appointment as sales manager of Ormes, Inc., New York, Victor wholesaler, was announced in the December issue of *The World*, assumed his new duties on January 2. Mr. Davin, accompanied by his family, arrived here from Chicago, December 30, and since January 2 the Ormes telephone has been kept busy with congratulatory messages from the dealers throughout this territory who are giving Mr. Davin a royal welcome.

As soon as he reached here Mr. Davin was informed by the Talking Machine Men, Inc., the local dealer organization, that he had been appointed a member of the entertainment and service committees and would also be in charge of press and publicity affairs. Prior to leaving for Chicago Mr. Davin was one of the most active members of this Association and he is

getting back into harness with all of his old-time vigor.

Mr. Davin's many friends in the trade received a Christmas reminder from him in the shape of a paper-bound book entitled "Take It From Me." This publication, now running in its sixth edition, can be read to advantage by every man, whether he is an employer or employe, and some of the paragraphs are particularly applicable to the activities of retail and wholesale talking machine men.

USEFUL GIFTS FOR DEALERS

The American Talking Machine Co., well-known Victor distributor, of Brooklyn, N. Y., presented to its many friends in the trade, as a Christmas token, a key-container. This particularly useful present is in the form of a heavy leather tan wallet to which numerous keys can be attached in a simple manner. R. H. Morris, general manager of the above company, states that the year 1922 was one of the most satisfactory in the history of his organization.

THE EMPIRE UNIVERSAL TONE ARMS

Will Give Your Product Individuality That Will Greatly Strengthen Its Selling Force

Send for sample of our new
Tone Arm for Portable
Machines.

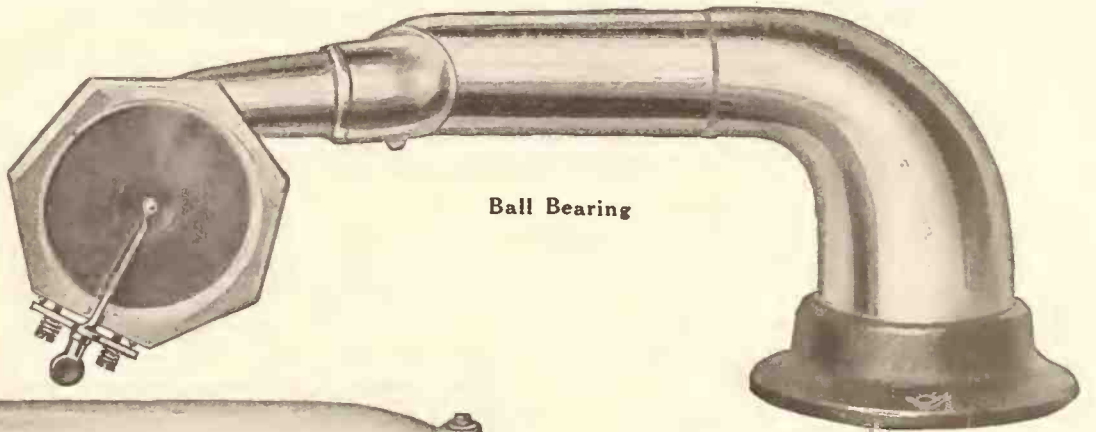

Ball Bearing

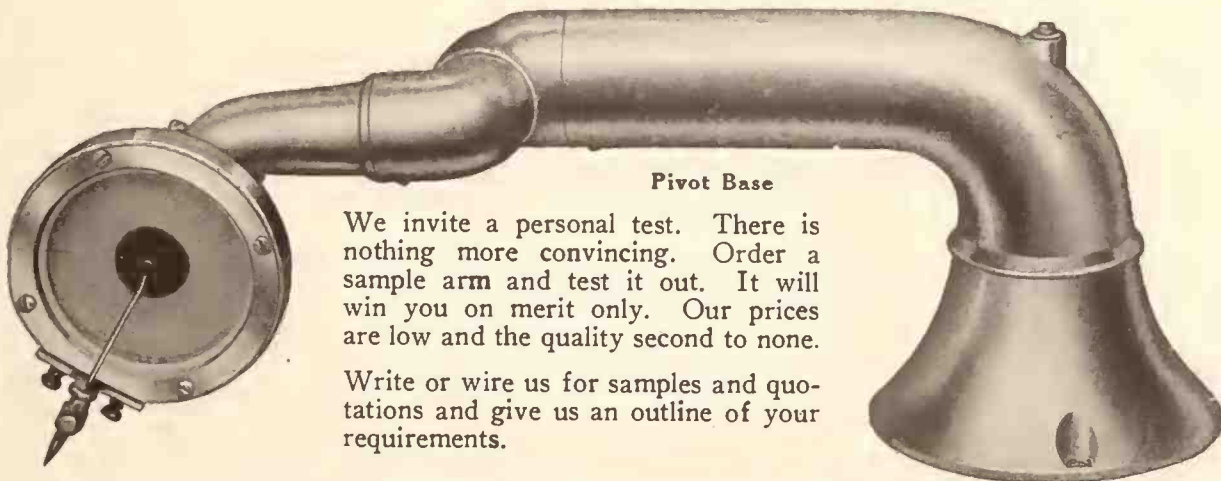

Pivot Base

We invite a personal test. There is nothing more convincing. Order a sample arm and test it out. It will win you on merit only. Our prices are low and the quality second to none.

Write or wire us for samples and quotations and give us an outline of your requirements.

THE EMPIRE PHONO PARTS COMPANY, 1362 East Third Street, Cleveland, O.

Established in 1914

Manufacturers of High-Grade Tone Arms and Reproducers

W. J. McNAMARA, President

Cable Address "Emphono"



You start in step-ping a-long, you can't— go wrong, do-ing the "Dum-bell"—

DUMBELL

A **STUMBLING** FoxTrot Full of **TRICKS**
by **ZEZ CONFREY**—

"You can't go wrong
With any **FEIST** song"

LOS ANGELES

*Southern California Association Gives Benefit Concert—Unusual
Co-operation—Opens Café for Employees—Visitors—The News*

LOS ANGELES, CAL., January 3.—Business throughout the entire district of southern California and in the city of Los Angeles was most satisfactory throughout the holidays, more especially during the last few days preceding Christmas, and in many cases exceeded the largest calculations and expectations. Rain fell intermittently in the first week or so of December and held back the shopping to some extent, but when it cleared and was succeeded by beautiful sunshine and mild days, which continued without interruption until the Saturday before Christmas day, the crowds thronged the streets and stores and more than made up for any lost time. Most of the record departments on the last few days presented an appearance of pandemonium and the sales staffs were taxed to their utmost. The average price of phonographs which were sold during the holidays was in excess of that of any previous year.

Association Gives Benefit Concert

A very successful concert was given under the auspices of the Music Trades Association of Southern California at Philharmonic Auditorium on December 16, the gross proceeds from the sale of tickets being devoted to funds for the poor children of Los Angeles. Eighteen different charities received checks of sums ranging from one hundred to three hundred dollars apiece. The program was given by nationally famous artists whose homes are in Los Angeles, and included Charles Wakefield Cadman, Carrie Jacobs Bond, composers; the Zoellner Quartet, Luboviski, the violinist, and many others. The sale of tickets was undertaken by the various music stores and it is particularly worthy of mention that two houses—the Starr Piano Co. and the Fitzgerald Music Co.—outstripped all others. H. L. Nolder, Western general manager of the former, and

H. C. Braden, general manager of the latter, threw their entire energies and those of their sales force into the work and sold many times over the quotas which were allotted them.

Cheney Jobbers Utilize Showrooms

The wholesale headquarters of the Munson-Rayner Corp., distributor of Cheney phonographs, in the Knickerbocker Building, are noteworthy for their very handsome display rooms, which, under ordinary circumstances, have been used for the wholesale trade only. However, special arrangements were made by Mrs. H. P. Howard, manager of the Parmelee Dohrmann Co.'s Cheney department, with the Munson-Rayner Corp. whereby retail customers of her department could go to the wholesale showrooms in the evenings during the busy holiday rush. The Parmelee Dohrmann Co. closed its doors at 5:30 p. m., while most music stores at this time of the year remained open until 9 p. m. A number of sales were effected through this most excellent arrangement.

Older Part of Town Busy

Schireson Bros., whose store is situated in the older part of town on North Main street, reported that business in their Victrola department for December far exceeded that of any previous month in their history, and would have been still further increased if they had been able to supply the Fall demand for Victor Mexican records.

Customers Crowd Elevators

Irving C. Westphal, manager of the Brunswick, Edison and Victrola departments of the Southern California Music Co., is enthusiastic over the wonderful December business which his department received. The elevators to the third floor, where the department is located, were thronged day after day with phonograph and record customers.

Wholesalers Jubilant Over Business

The several jobbers and distributors are much gratified by the wonderful volume of business which they have enjoyed throughout December after a remarkable November. Cheney, Columbia, Burnham, Brunswick, Edison, Starr, Strand and Victor all report that they were practically sold out.

Victor Representative Here

R. P. Hamilton, Pacific Coast representative of the Victor Talking Machine Co., arrived here about the middle of December and spent Christmas in Los Angeles. He will leave in a few days for San Francisco.

Brunswick Official Visits

H. F. Davenport, secretary of the Brunswick-Balke-Collender Co., has been spending a few

days in Los Angeles and will return to Chicago in the very near future.

Opens Café on Roof for Employees

They were so busy at the Platt Music Co. that it seemed that there was no time to eat. So, in order to save his people from the tiring job of waiting around in crowded restaurants, President Platt opened a café on the roof of his building where members of the Victrola department and others have been enjoying lunches and suppers—all at the expense of the Platt Music Co.

Wholesale Man Returns

After an absence of several months, during which time he was with the San Francisco branch, W. C. (Bill) Campbell, of Sherman, Clay & Co., has returned to Los Angeles and is now in charge of the stockrooms at the new headquarters at Tenth and Santee streets.

Fitzgerald Sales Large

The Fitzgerald Music Co.'s Brunswick and Edison departments, under Manager Mansfield, showed an enormous increase of sales over previous months. A noticeable feature was the sale of a very large proportion of high-priced period models.

Unit Construction President Here

Rayburn Clark Smith, president and treasurer of the Unit Construction Co., spent a few days in Los Angeles early in December and visited the trade in company with J. J. Grimsey, Los Angeles manager of Walter S. Gray Co., agents of the Unico products in this territory.

Arizona Business Improves

Howard Brown, Brunswick wholesale manager of the Los Angeles branch, reported that the quota of business set by the Chicago headquarters for his branch this year was passed early in November—the quota was no light one either. He also stated that business has recently much improved in Arizona. Among the new Brunswick dealers are Kerr Mankin, of Phoenix; Ben Tilton, of Preston, and Leonard Music Co., of Miami.

DAVENPORT CO. FILES ARTICLES

DAVENPORT, IA., January 8.—Articles of incorporation have been filed by the Davenport Phonograph & Accessories Co., this city, to manufacture and sell talking machines, radio supplies and musical instruments, with a capital stock of \$25,000. The officers of the concern are E. W. Hemping, president, and Clara M. Hemping, secretary and treasurer.

MOTORS

Ready for Delivery

Double Springs; plays two 10-inch Records; suitable for Portable Phonographs. Sample, \$3.75. Larger motor playing two to three 12-inch Records; suitable for Phonograph selling for \$100. Sample, \$5.75.

MERMOD & CO., 874 Broadway
N. Y.

"Superflake" Graphite Spring Lubricant

For PHONOGRAPH MOTORS

A carefully prepared lubricant containing GRAPHITE of the finest quality

Will not get hard, become rancid or leak

**PACKED IN TUBES, CANS and BARRELS for
JOBBERs, DEALERs and MANUFACTURERs**

**SPECIAL GRAPHITE for
RECORD MANUFACTURERs**

Superior Flake Graphite Co.

General Offices: 76 West Monroe St., CHICAGO
Department J Warehouse in Chicago

CROSLEY

Radio Apparatus

Better—Cost Less

A Four Tube Receiving Set

\$55



CROSLEY MODEL XXV

A Console Model of great beauty. Consists of a four-tube panel incorporating the same units as the Model X. This cabinet is arranged to take the Model R-3 Magnavox that can be quickly installed and hooked up to the set, but the Magnavox is not furnished at the price. Cabinet also contains space for "A" Battery and "B" Battery and battery charger if desired. It is guaranteed to bring in broadcasting stations up to one thousand miles or more, loud enough to be heard all over the room. This beautiful instrument, without phones, batteries or tubes, sells for.....\$150.00

CROSLEY EXPERIMENTAL UNITS

are designed to help the experimenter by furnishing audion detectors, variometers, condensers, audio frequency units and their combinations in individual cabinets. These units can be hooked up by simple binding post connections. Adapted for use with either 6-volt or 1½-volt batteries.

Write for Catalog of these Units

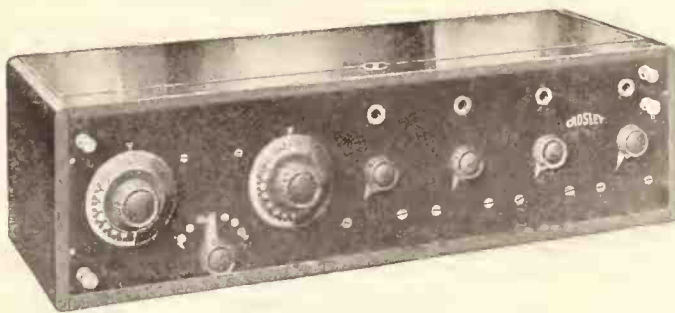

CROSLEY MODEL X. This four-tube set is the most popular on the market to-day. It consists of one stage of Tuned Radio Frequency Amplification, Audion Detector and two stages of Audio Frequency Amplification. The Crosley Model X is built on scientific principles and is the acme of simplicity and efficiency. Especially is the Tuned Radio Frequency Amplification popular. With this set, listeners in Florida have heard broadcasting from Winnipeg, San Francisco and Honolulu. We cannot be too emphatic in recommending this set to everyone. Without phones, batteries or tubes, only.....\$55.00

CROSLEY RECEIVER MODEL VIII (three tubes)..\$48.00

CROSLEY RECEIVER MODEL VI (two tubes)....\$28.00

CROSLEY HARKO SENIOR MODEL V (one tube).....\$15.00

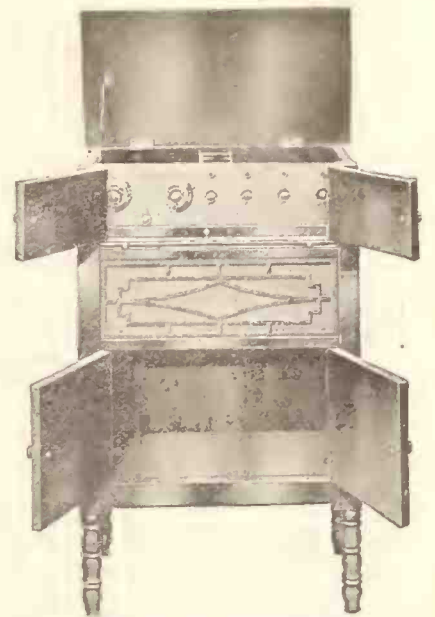

CROSLEY MODEL XX

A Beautiful Cabinet Model incorporating the Model X Receiver. Has all the splendid qualities of the Model X and in addition it has compartments for batteries and a large amplifying chamber. Price without phones, batteries or tubes...\$100.00

CROSLEY CABINET MODEL XV. Same as the above but without battery compartment and designed to rest on a table. Price.....\$70.00

CROSLEY PARTS are the last word in simplicity and efficiency. We make everything necessary for the building of any type of set and our prices are lower than anything on the market.

Write for Our PARTS Catalog

Talking Machine JOBBERs and DEALERS

You are the logical men to handle Radio Apparatus as we explained on this page last month. This will be a *Radio Year* and you will greatly increase your profits by supplying Crosley—Better—Cost Less—Radio Apparatus.

The Instruments shown on this page are the height of simplicity and efficiency as well as beautiful pieces of furniture. Nothing better on the market at anywhere near their price. We are prepared to fill any sized order immediately. Write to-day for catalog.

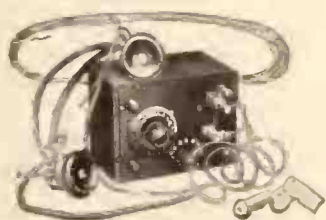

CROSLEY CRYSTAL RECEIVER MODEL I

A complete crystal receiving set equipped with antenna, phones and necessary hardware, ready to install. Has a range up to 30 miles and will bring in local broadcasting loud and clear. Price.....\$25.00

HARKO SENIOR MODEL V

This is a one-tube set of exceptional merit, and consists of Tuner and Audion Detector, mounted in a mahogany finished cabinet. This set has a range of several hundred miles, and, under favorable conditions, listeners in Denver have heard Schenectady and Newark. Price without tubes, batteries or phones.....\$15.00



Liberal Discounts to Jobbers and Dealers

CROSLEY MANUFACTURING COMPANY

1226 ALFRED STREET, CINCINNATI, OHIO



More of Van and Schenck's good harmony stuff—"Georgia Cabin Door" and "Kentucky Echoes" on Columbia New Process Record. A-3753.

**Columbia Graphophone Co.
NEW YORK**

L. FRIEDL NEW WANAMAKER MANAGER

Well-known Talking Machine Man Appointed Manager of Local Wanamaker Department—Ideally Qualified to Win Success in New Post

Lambert Friedl, one of the best known members of the talking machine trade in the East,



Lambert Friedl

has been appointed manager of the talking machine and musical merchandising salons of John

Wanamaker, New York. Mr. Friedl assumed his new duties on December 28 and within the course of the next few weeks will probably have important announcements to make as to his plans for the coming year.

The appointment of Mr. Friedl as manager of the John Wanamaker talking machine department will be welcome news to the local trade, as Mr. Friedl is thoroughly familiar with every phase of talking machine selling and is recognized as one of the best posted merchandising experts in the industry. For many years he was associated with the Columbia Graphophone Co., and as manager of the local wholesale branch of that company attained phenomenal success. Mr. Friedl has at all times been a keen observer of the dealers' retail problems and has helped many of the dealers in the development of practical merchandising ideas. Prior to joining the Columbia organization Mr. Friedl was a retail

phonograph dealer in Ohio and he, therefore, brings to his new position an exceptional knowledge of the talking machine field as a whole. Subsequent to his Columbia activities Mr. Friedl won success as manager of the New York distributing division of the General Phonograph Corp.

The talking machine salons of the New York store of John Wanamaker constitute one of the finest talking machine warerooms in the country. Located on the mezzanine floor of the new building, the salons are noteworthy for the artistic refinement of their furnishings and decorations, which in every way are in complete accord with the international prestige and dignity of the John Wanamaker institution. The lines handled in the Wanamaker talking machine salons are Victor, Brunswick, Cheney, Sonora and Columbia machines and the record department is completely stocked.

VICTOR SCHOOL IN OKLAHOMA CITY

Victor Course in Salesmanship to Be Held Under Auspices of Oklahoma T. M. Co.

OKLAHOMA CITY, OKLA., January 9.—The Victor School of Selling is scheduled for a four days' session in Oklahoma City during the week of February 26 under the auspices of the Oklahoma Talking Machine Co., Victor distributor, 626 West Main street, this city. The course will be similar to those held in other cities and Victor dealers in the Southwestern territory will thus have an opportunity of taking advantage of this most practical course of instruction in selling Victor merchandise.

CLEVER STUNT BOOSTS SALES

ALTOONA, PA., January 8.—A unique stunt was recently staged by the W. S. Aaron general merchandise and furnishing store, this city, which resulted in a general boost of talking machine record sales. The establishment devoted one large front window to the demonstration by six students of the value of the talking machine as an aid in dancing instruction and physical training.

The sales force of the Victor record department of the Ross P. Curtice Co., Lincoln, Neb., has been augmented by the addition of Mrs. Frances Voss and James Henlein.

Increase Your Edison Record Business from 25% to 50%

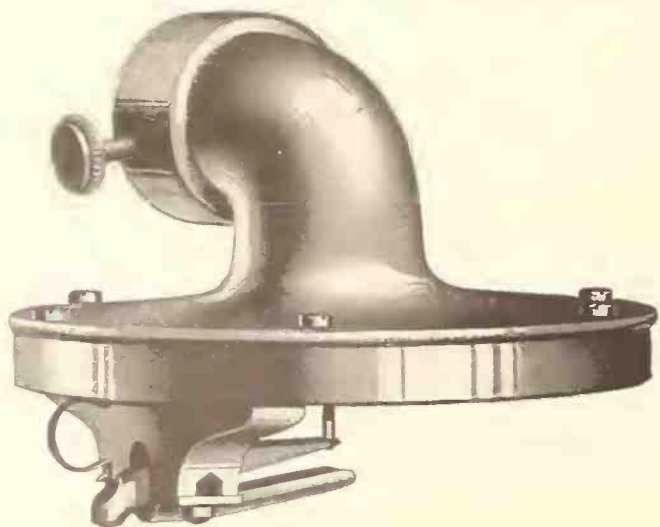

CLARAVOX
CLEAR VOICE

Instantly Attached

Diamond Pointed

The Claravox has opened new and profitable sales possibilities for Edison Records.

Put out house to house canvassers, demonstrating Edison Records as played by the Claravox on other makes of talking machines, and your business will show profits you have never known before.

The Claravox is a proven product; not only proven in reproducing qualities, but also as a device which *does not in any way cut or injure Edison Records*. Test records have been played hundreds of times with no apparent evidence of wear.

The Claravox is exactly the same weight on the record and has exactly the same size and shape of diamond point as the original reproducer for playing Edison Records.

Order your Claravox reproducers to-day and employ your canvassers while the talking machine is in season.

THE CLARAVOX CO.

Youngstown

OHIO



FORGING AHEAD

in 1923

During 1920-1921 and 1922 conservative, dependable employes and business men were most concerned in demonstrating their ability to weather a business depression even though the temporary sacrifices were heavy.

The inevitable reaction and readjustment following the war period of inflation took a heavy toll and those who could not forge ahead but "held the line" and proved their dependability were building for the future. These employes and business men held their jobs and customers. They are now ready to forge ahead in 1923. The business outlook justifies optimism and confidence.

The Blackman policy has been to reflect "Victor Supremacy and Dependability"—not by words but by deeds. During 1922 we practically reorganized our business, realizing that we must all experience the "Survival of the Fittest" and that "hard times" were not coming but "easy times" were going.

Having maintained our financial stability and served conscientiously Blackman Victor dealers, according to our obligations as we saw them, we consider that we have at least "held the line" and are now ready to forge ahead to bigger things in 1923.

Many Victor dealers have considered it advisable to distribute their business among several Victor Wholesalers in order to get good service. We do not believe this is going to be a good policy in 1923. It increases the cost of doing business and makes impossible, or at least delays, economies which might be shared by dealers.

We are prepared to accept the responsibility of handling a Victor dealer's entire business if within a reasonable distance of New York. There is no kind of service or support that is desirable, reasonable and dependable in the long run, that we cannot extend.

Mr. Victor Dealer, we recommend that you give your business to *one* Victor Wholesaler who should have preference on all of your orders during 1923 and then select another, if necessary, for "shorts." Analyze carefully before you choose. We make this recommendation regardless of the wholesaler you select as first choice, recognizing that we have worthy competitors.

With the Victor as your line and Blackman as your wholesaler, the combination will help you to forge ahead in 1923. Think it over, Mr. Victor Dealer, and have a chat with us about it.

J. NEWCOMB BLACKMAN.

Blackman
TALKING MACHINE CO.
28-30 W. 23RD ST. NEW YORK N.Y.
VICTOR WHOLESALE DISTRIBUTORS

Featuring the MUSICAL POSSIBILITIES of the TALKING MACHINE

[EDITOR'S NOTE.—This is the twenty-second of a series of articles by William Braid White, devoted to the various interesting opportunities which prevail in the domain of education for the retailer of talking machines. The subject is one of great interest and we commend these articles to the consideration of all who are devoting attention to the featuring and developing of the musical possibilities of the talking machine.]

A RECORD INTERLUDE

At this, the beginning of a new year, let us take thought of some matters which have not had our attention for some time past, but which will allow us, in considering them, to take a rest for the moment from the more strenuous studies we have been making in the art of music and in the mysteries of musical form. The

interlude will do none of us any harm and probably will do most of us some good.

Twenty years ago, when the great record libraries were being inaugurated, it became the settled policy of the most important manufacturers to build up from the bottom a collection of music of the very highest class, recorded by artists of the greatest eminence. This policy was, in the beginning, apparently most reckless, but those who originated it had both the wisdom to choose the right path and the courage to stick to it. Public taste was not ready for them, but they knew that on the one hand they could prepare public taste for their wares and on the other hand that, when once prepared,

this taste would be sufficiently alive and self-perpetuating to assure a constant and growing popularity for the fine records they were then getting out and for any others they might, year by year, choose to publish.

"Priceless Value"

To-day the value of these libraries is absolutely beyond price. There is nothing like them in the world. Not because it is from them that the big sellers come, but because these records sell steadily year after year, because they never die and never even grow stale. They remain not alone a monument to the wisdom of their originators, but a standing denial of the lie that the American people want only the cheap, the trashy and the stupid in music.

Now, it is well known to all of us that for quite a long time the general retail opinion was dead against the high-class policies and that many a dealer wished many a time that high-class records were "easier to sell." Yet to-day, as everyone knows, the high-class policy has abundantly justified itself.

During the last few years, since the dance craze became acute, the policy of those record manufacturers who had not already a vast reservoir of high-class recordings behind them was, naturally enough, directed towards taking care of the immediate demand and of nothing else. For a year past, however, there have been abundant signs that this policy is decidedly in eclipse and that everyone who has any idea of staying in the record game permanently must begin to accumulate a library of standard selections—instrumental and vocal.

Some Examples That Strike

It is unnecessary to mention names. It is far better to look through the record monthly lists and see what is going on. One who does this will at once perceive that there is a marked change in evidence. Little by little, yet with a steadiness which cannot be mistaken, the stream of high-class recordings is emerging into sight. One great house proceeds to bring out no less a work than Schubert's Unfinished Symphony, from records made in Europe, and note for note complete. Now, it is not unusual to bring out an orchestral record of high-class music, but the practice has always been to cut down and condense it until it will fit in at least on one double-faced record. The present recording, however, is done in three double-faced records, and not a note of the two movements is omitted. One may wonder whether the dealers, when they saw the announcement of this recording, realized that it signified a great deal more than the bare fact.

What It Signifies

For the bare fact involves the evident belief that the public has reached a point in musical appreciation where it not only will endure, but actually will want, its art music served up to them in complete form, not only in part. One is reminded of how Theodore Thomas once was criticized—it was during Chicago World's Fair days—for daring to perform a whole symphony at a concert. How dared he assault the ears of his patient listeners, asked the newspaper. One movement of a symphony was bad enough; a whole symphony was intolerable. The world certainly does move.

More Signs

During these last two or three months, moreover, many other very interesting facts are to be recorded which all go to show how the tide is fast moving out in the right direction. Another great record house has announced a list of publications by eminent vocal and instrumental artists, which have been hitherto available only in its European lists. Over in London this same company's great recording organization has recently brought out a complete re-



The Diamond Juvenile Console

Created twelve months ago; today the most popular children's talking machine on the market. Many dealers use it as the basis for a special children's booth. Makes appealing window display. Sells easily and increases sale of both juvenile and regular records. A profit producer you cannot afford to overlook.

A Real Musical Instrument for Children

Guaranteed Heineman Motor

Cabinet: substantially made of hardwoods and veneers. 24 in. high, 14 in. wide, 28 in. long.

Finish: beautifully enamelled in gray, blue, ivory or mahogany. Grille in blue or old rose silk.

Motor: by Heineman, cut gears, cast frame, fully guaranteed, removable motor board.

Tone arm: die cast and nickel plated. Artois reproducer.

Turntable: 9-inch, felt faced.

Plays all Records up to 10 inch, including children's records such as Bubble Books.

Write Jobber or direct for full information and special 1923 dealer's proposition.

THE DIAMOND PRODUCTS CORPORATION

Executive Offices and Showroom:

200 Fifth Avenue, New York

DISTRIBUTORS:

A. C. ERISMAN & CO.
174 Tremont Street, Boston, Mass.
CONSOLIDATED TALKING MACHINE CO.
227-229 N. Washington St., Chicago, Ill.

CABINET & ACCESSORIES CO.
3 West 16th St., New York
MUNSON RAYNOR CORPORATION
643 So. Olive St., Los Angeles, Cal.

It gives no opportunity for brilliant pyrotechnics, no dazzling display of skillful bowing, but the "Angel's Serenade" coming like a low, sweet song from the violin of Toscha Seidel creates the illusion of the far-off voice of an angel and the answering tones of a child. 98046.

**Columbia Graphophone Co.
NEW YORK**



recording of Beethoven's lovely and famous E flat major piano concerto, with Frederic Lamond at the piano and Sir Henry Wood conducting the Queen's Hall orchestra. This is note for note complete, in six double-faced records. No one doubts that this recording will soon appear in the American lists. Likewise another great American house is bringing out in London recordings of some movements of that astonishing orchestral "hit" of the first few years, Gustav Holst's "The Planets," which has been performed with great success by most of the big American orchestras within the last season or so. And other efforts are praiseworthy being made, which can be watched now and commented on later.

Practical Progress

In a word, the tide has definitely turned and we are all due to see a big effort during the coming year to bring fine music and the people much closer together, by means of the talking machine. It would be entirely wrong if this were not so. For American musical taste is moving along by steps ever longer and more confident. Let any music merchant who allows himself to be deafened for the moment by the clamor of the ultra popular stuff stop to realize how many symphony orchestras, of the first class and permanently organized, there are now in America compared with the number that existed, say, in 1914. To-day New York has half a dozen, among which three are of the highest class. Chicago has three, one believed by many to be the first in America. Philadelphia has one, which disputes the primacy with Chicago, and with Chicago alone. Boston has a magnificent organization; so have Minneapolis, St. Louis, Los Angeles, San Francisco, Detroit. All these are in what may be called the first class. Of the second order there are already twice as many in smaller cities, and others are growing up every week almost. Chicago has never in past years been able to support chamber music organizations, so it seems. But to-day she has three string quartets of real merit, a piano trio of eminent merit and now a piano quartet (violin, viola, cello, piano), all devoting themselves with single-minded desire to the highest of art music. And so it goes everywhere. The people, the great American people, are waking up to the meaning, the beauty, the charm, the worth of good music.

A Great Part to Play

Now, the talking machine in all this development has a great, a very great, part to play. Whoever, indeed, can, should learn to play some musical instrument or to sing, no matter how amateurishly, for the greatest pleasure in music is the pleasure which one derives from making it. But next to actual making is the pleasure of appreciative critical listening. In fact, it is undoubtedly true to say that America has too many music makers and too few critical listeners. The talking machine is the finest maker of listeners, critical listeners, that can be imagined, next to the personal contact of the actual musicians. And in some ways the talking machine is better still, for with it there is no

chance to have one's judgment warped by the personal magnetism of a performer whose face and manner constitute as much a part of his or her success as the music itself. The talking machine gives us the music undistorted by personality, but with all the charm of personality, nevertheless.

Wake Up! Retailers

It is time for the retail men to wake up. The big successes in this business can only be built on the permanent things in music, which the talking machine does. The ephemeral stuff has its place and does its part in making sales, in piling up the needed revenues. But the permanent business comes to that store which becomes known as the place where the lover of high-class music can go and get high-class service.

Now is the time to begin training one's clerks to sell better music or records intelligently. Now, in fact, is the time to explore one's own record bins to study the high-class numbers and

come to some clear opinion about them; for from now onwards the tendency will be more and more strongly towards those records. He who best knows how to sell them will be he who is most likely to make an outstanding success in the talking machine business.

NEW GRIFFITH PIANO CO. BRANCH

NEWARK, N. J., January 8.—The Griffith Piano Co., with headquarters on Broad street, and operating a branch store in Scranton, Pa., has completed arrangements for the lease of another wareroom in the Paramount Theatre Building. The concern, in addition to handling a complete stock of fine pianos, is the northern New Jersey distributor for Sonora phonographs.

Mrs. Loraine Guy, of the record department of the Wiley B. Allen Music Co., San Diego, Cal., recently resigned to be married. Mrs. Rhoda Rumsey is her successor.

**Dealers Everywhere Are
"Cashing in" on
VIOLIN SPRUCE
REPRODUCERS**

Thousands of phonograph owners already agree with the verdict of famous artists who have tested the Violin Spruce Reproducer and pronounce it to be "the perfect reproducer." It will improve the tonal qualities of any good phonograph. Dealers featuring Violin Spruce Reproducers are making big profits in satisfying the growing popular demand.

Our new Edison attachment opens the way to still more profitable business. It is the only attachment that really brings out the full possibilities of lateral cut records on Edison instruments.

The earlier you stock these Reproducers, the greater will be your profits and the more secure your hold on future business in your locality. Don't delay—introduce these wonderful Violin Spruce Reproducers to your customers and let them hear and appreciate the improvement.

Write Today For Full Information

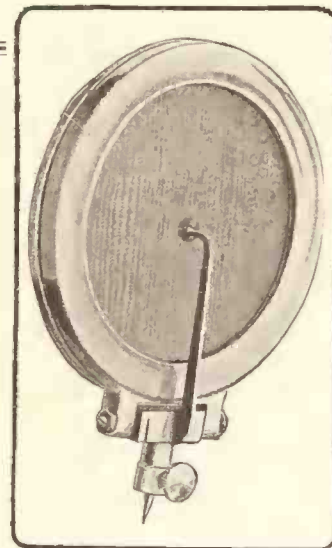

VIOLIN SPRUCE REPRODUCER

fits all of the better known phonographs. The only reproducer which can competently play piano records—it is also notable for its clean-cut reproduction of instrumental music and its fidelity to voice. It eliminates all metallic sounds, and mellows with use like a violin.

**Retails for
\$7.50**

(Usual Dealer's Discount)

**THE DIAPHRAGM COMPANY
5005 Euclid Avenue, CLEVELAND, OHIO**

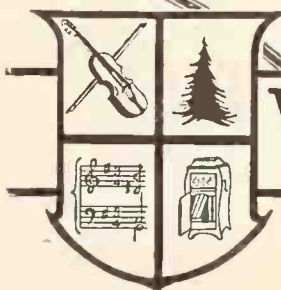

Violin Spruce Diaphragm

"Creole Fashion Plate's" Latest Hit

I'M THROUGH

SHEDDING TEARS OVER YOU

FOX TROT BALLAD

BY THE WRITERS OF "NOBODY LIED" KARYL NORMAN & EDWIN J. WEBER



JEROME H. REMICK & CO.
NEW YORK - CHICAGO - DETROIT

KANSAS CITY

Trade Gains Last Year Despite Drawbacks—J. W. Jenkins' Sons Music Co. Increases Capital—Month's Activities of the Trade

KANSAS CITY, Mo., January 3.—As the talking machine business for the year closes the dealers in Kansas City are looking back and considering the various features and problems they have confronted during that period and are also looking forward to the future.

"In many ways it has been an unusually hard year," Fred Jenkins, of J. W. Jenkins' Sons Music Co., said. "The farmer not knowing what he would get for his crops, a goodly number of strikes in this territory, and new models coming into the business, with the added amount of advertising and work which it takes to put a new commodity on the market, have helped to make the music dealer a year older and wiser than he was January, 1922."

In spite of these things there was a favorable increase in the business of all the dealers in the territory over the previous year, and Manager Briggs, of the Brunswick, predicts that just as soon as the crops of the farmers are moved and they get their returns business should just boom, while right now sales in Kansas City and other commercial centers are very favorable.

Each of Kansas City's wholesale houses reports a different experience in the quality of the instruments demanded. One house advises that most of its sales have been in the middle class, another that until the beginning of Christmas sales the middle class of instruments were most in demand, but that the Christmas demand was for the more expensive models, while a third states that all year there has been a big demand for the period model consoles.

The Brunswick Co. has just received a carload of console models and is sending them

straight to the dealers, over the territory, who have been waiting for them.

The J. W. Jenkins' Sons Music Co., Victor wholesalers, filed notice with the Secretary of State the last of December that the company's capitalization had been increased from \$100,000 to \$3,500,000. The corporation franchise tax paid to the State amounted to \$1,700.

The Jenkins house, established about forty-five years ago, now has thirteen branch stores. The first branch store was established at St. Joseph about fifteen years ago. The company has grown from a small, unpretentious office at 615 Main street, where forty years ago it boasted of a stock of twenty pianos, to one of the largest retail music stores in the Southwest. The other branches are in Kansas City, Wichita, Hutchinson, Salina, Topeka and Independence, Kan.; Fort Smith, Ark.; Joplin, Mo.; Oklahoma City, Bartlesville, Tulsa and Muskogee, Okla.

The Schmelzer Co., Victor wholesaler, held a salesmen's meeting to close the business of the old year and start the new year with a boom. A. A. Trostler states that the salesmen are enthusiastic over prospects for the future. They were all in Kansas City from the entire trade territory for the special conference.

The George B. Peck Dry Goods Co. has sold its phonograph department to the Davidson Furniture Co., 1204 Main street. The Davidson Co. will handle Victor goods exclusively.

The Ukrainian National Chorus, exclusive Brunswick artists, will be in Kansas City the thirtieth of January and in Leavenworth, Kan., the thirty-first. Mile. Oda Slobodskaja, a member of the Ukrainian National Chorus, appeared

in Kansas City with Irene Castle during her latest engagement here as the soloist. Other exclusive Brunswick artists appearing here recently are: Claire Dux, Bronislaw Huberman, violinist; Irene Williams, Elly Ney, pianist, and Mario Chamlee, the tenor.

William N. Huckins, of the Huckins Music House, Trenton, Mo., recently visited the Kansas City branch of the Columbia Co. and reported considerable activity in school sales of Columbia Grafonolas and records. He stated that the Parent and Teachers' Association of Trenton, Mo., purchased a Columbia Grafonola for the local school from which he received considerable publicity, as one of the newspapers gave him front-page space relative to the wonderful demonstration and the keen sales ability shown when making the sale.

McDowell & Castator, of Ponca City and Pawhuska, Okla., recently decorated the store inside and out and put a large banner across the entrance reading as follows: "Great Musical Festival Now On." They employed a local jazz orchestra and reported having sold a considerable number of Grafonolas from this form of advertising.

Paul Eckler, of McDowell & Castator's Pawhuska, Okla., store, states that the Indians living in Pawhuska, who are of the Osage tribe, considered the wealthiest tribe in existence, received the largest bonus given them in several years from the United States Government and insisted on buying Grafonolas.

O. D. Standke, of the Grafonola Shop, has recently redecorated the interior of his store, and also reports large sales during the holiday season.

J. C. Clinkenbeard, manager of the Grafonola department at the North-Mehornay Furniture Co., was ill for several days and remained away from the store, but returned in sufficient time to "pep" up the department for the holiday business. He reports sales for the month of December in excess of any month this year.

Way down up on the Sil-ver Swan-ee some-one's call-ing Way down up on the Sil-ver Swan-ee Tears are fall-ing

SILVER SWANEE

A SMASHING HIT WITH EDDIE CANTOR IN "MAKE IT SNAPPY"

By EDDIE CANTOR & JEAN SCHWARTZ

A MARVELOUS FOX-TROT TUNE FOR ORCHESTRAS

JEROME H. REMICK & CO.
NEW YORK CHICAGO DETROIT

SONORA CHRISTMAS WINDOW ARTISTIC

Display in Fifth Avenue Salons Attracts Attention of Passers-by—Instrument Featured Wins Hearty Praise From Artistic People

One of the most artistic window displays ever presented in the local trade was prepared by the Fifth avenue salons of the Sonora Phonograph Co. during the holiday season. This beautiful window attracted the attention of thousands of passers-by along Fifth avenue who keenly appreciated the unique character of the display.

The instrument in the center was one es-

with red berries and leaves, and large crimson ribbons were tied around the sprays on both sides—an effective combination.

T. M. M. DINNER ON APRIL 25

Annual Entertainment Will Be Held at Hotel Pennsylvania—Many Unique Novelties Planned for This Year's Event

The entertainment committee of the Talking Machine Men, Inc., the local dealer organization, held a meeting recently at which preliminary plans were made for the annual banquet and ball, and according to these plans this event will take place on Wednesday, April 25, at the Hotel Pennsylvania, New York. In addition to the various visiting orchestras and the appearance of famous artists there will be introduced several unique novelties at this year's entertainment. It is planned to have the Mardi Gras spirit predominate and souvenirs and favors will be distributed to all in attendance.

In order to provide more room for dancing this year the balcony boxes will be given over to tables, and these balcony tables with the tables

while they are available. The tables in the balcony will accommodate ten people and those alongside the dance floor, twelve.

FORM NEW SONORA JOBBING CONCERN

Ohio Sonora Phonograph Co. Formed to Cover Ohio, Michigan and Kentucky

It was announced recently by the Sonora Phonograph Co., New York, that the Ohio Sonora Phonograph Co. had been formed for the purpose of distributing Sonora products in the States of Ohio, Michigan and Kentucky. For the time being the distribution will be under the supervision of the executive offices in New York until such time as the new jobber is selected. Frank J. Coupe, vice-president and director of sales of the Sonora Phonograph Co., is now making his headquarters in Cleveland and the activities of the new company are at present in the hands of J. T. Pringle. A sales force is now in the field visiting the Sonora trade and co-operating with the dealers in every possible way.

HOLIDAY SOUVENIRS FOR DEALERS

As a holiday souvenir, Emanuel Blout, the Victor wholesaler, of New York City, presented a heavy bronze and brass letter-opener to dealers. This useful gift carries the Blout imprint and should, during its daily use, remind the many friends of that organization of the service and co-operation extended to the Blout customers during 1922.

VICTOR FOREIGN LANGUAGE RECORDS

Included in the January offering of Victor records are a number of selections in the following languages: Arabian, Bohemian, Finnish, French-Canadian, German, Greek, Hebrew-Yiddish, Hungarian, Italian, Mexican, Polish, Russian, Swedish.



Window of Sonora Co.'s Fifth Avenue Salon Much Admired

pecially designed for a wealthy admirer of the Sonora, and its crimson and gold decorations served as a powerful magnet to attract attention. The colors of the hanging were green, the floor of the window being profusely scattered

on the outer edge of the dance floor will be considered preferable locations. It is suggested that dealers and jobbers make arrangements for their tables as soon as possible, so that they may secure these preferable positions

Columbia A-2 Grafonola and The Long Console

Here is your chance, Mr. Dealer, to cash in again on all the Columbia A-2 Model Grafonolas that you have sold. Every owner can make a handsome console out of his A-2 Grafonola in a jiffy with one of these Long Console cabinets.

The A-2 Grafonola slips easily into one compartment of the Long Console, through the back, no bother, no trouble. Cash in on this easy way to make another sale.



C-601
Price \$27.00



C-603
Price \$29.00



C-611
Price \$30.00



C-612
Price \$28.00

Specifications
Made in dark red Mahogany only. Two-piece top. 36 inches long, 34 inches high, 22 inches deep.

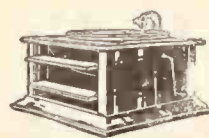

Columbia A-2 Grafonola

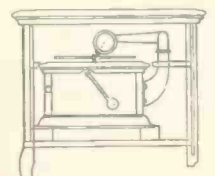

The Geo. A. Long Cabinet Co.
HANOVER, PA.

I get so all mud-dled up when ev - er I at - tempt to syn - co - pate,

ALL MUDDLED UP

THE NEW FOX-TUNE

HEAR IT NOW!

*"You can't go wrong
With any FEIST's song"*

BUFFALO

*Trade Optimistic Over Business
—W. J. Schottin Opens Branch
—Trade Changes and Activities*

BUFFALO, N. Y., January 8.—It would be difficult to find a more optimistic lot of business men than those of the talking machine trade in this city. The inability to supply the demands of the holiday trade has carried business well into the new year. The one thing that has helped the dealer is the reasonableness of the customer, who in many instances has expressed a willingness to wait until his order can be filled.

Frank E. Russel, sales manager of Neal, Clark & Neal, believes the new year will be one of substantial prosperity. In speaking of the outlook for 1923 Mr. Russel said: "Christmas Eve found a great number of people disappointed, for we simply could not supply the demand for talking machines. However, people who couldn't get the type of machine they wanted are willing to wait until their orders can be filled."

A great deal of business is being lost through the lack of the medium-priced models of Victors, according to O. L. Neal, of the Buffalo Talking Machine Co., Victor jobber.

E. R. Burley, successor to Burley & Bresinger, 332 West Ferry street, has one of the most attractive music stores in this section of the

State. Mr. Burley declared that in his opinion prospects for the new year are most favorable.

W. J. Schottin, who conducts the Genesee Phonograph Co. on Jefferson avenue, has opened a store at 106 East Tupper. He is carrying an attractive line of talking machines and other musical instruments.

When Van & Schenck, well-known Columbia artists, appeared here recently, they were passing the W. T. Grant store and they heard their popular ballad, "Who Did You Fool After All," being played. They dropped in to see how their song was selling and being recognized by the managers of the store were prevailed upon to autograph every copy sold. It proved a big attraction and resulted in many sales.

The Kurtzmann Piano Co., which has a large talking machine department, has increased its capital stock from \$100,000 to \$150,000. This concern has a large canvas painting in portrait study of Paderewski in its window display, in which are featured Victor records and Victor, Sonora and Cheney machines. The portrait painting is the work of one of the old employees of the Kurtzmann Piano Co.

In a full-page advertisement in the Jamestown papers Stransburg's Music House featured the Cheney Phonograph, developing a lot of business.

Goeller Furniture Co., of Buffalo, made a special Christmas drive on Master Tone phonographs.

Members of the Victor Talking Machine Association expect to resume their meetings in the very near future.

Charles Hoffman, of the Hoffman Piano Co.,

which handles the Brunswick talking machines and records, has been elected vice-president of the Lions' Club of Buffalo.

Joseph Dombrowsky, famous local orchestra leader and exclusive Columbia dealer, has opened an attractive new shop. The first floor is devoted to the sale of Columbia Grafonolas, records and piano rolls. The second floor is arranged in the order of a large musical reception hall and will be used as a Grafonola, piano and small instrument sales department.

H. S. Natowitz, of Lackawanna, has opened a new Grafonola shop. The store is located in the heart of the city and is handsomely arranged with instruments and records.

Manager H. B. Haring, of the Columbia branch, was presented with a beautiful English kit bag from the staff. Mr. Haring expressed his pleasure at the splendid spirit of loyalty and co-operation which has placed the Buffalo branch in the position it now occupies.

The music department of the Poppenberg department store at Main and Carlton streets now occupies the choicest location in the store. The musical instruments are arranged in a corner of the first floor, giving them a very large show window space. Since this firm discontinued its country and wholesale business it is redoubling its sales efforts in Buffalo and surrounding towns, paying especial attention to the talking machine and record business.

Among the visitors to New York recently were J. Elwood Easman, of the Easman Co., Newburgh, N. Y., and Rudolph Steinert, of the M. Steinert & Sons Co., New Haven, Conn.

FOR THE NEW YEAR

The Eclipse organization has built its fences for 1923, and is splendidly equipped to offer Victor retailers practical and helpful co-operation.

Particular attention will be paid this year to the development of the dealers' record business, and we will have many interesting announcements to make during 1923 bearing on this important sales topic.

ECLIPSE MUSICAL CO.

Victor Wholesalers

CLEVELAND, OHIO.

BETTER
BUSINESS

ECLIPSE

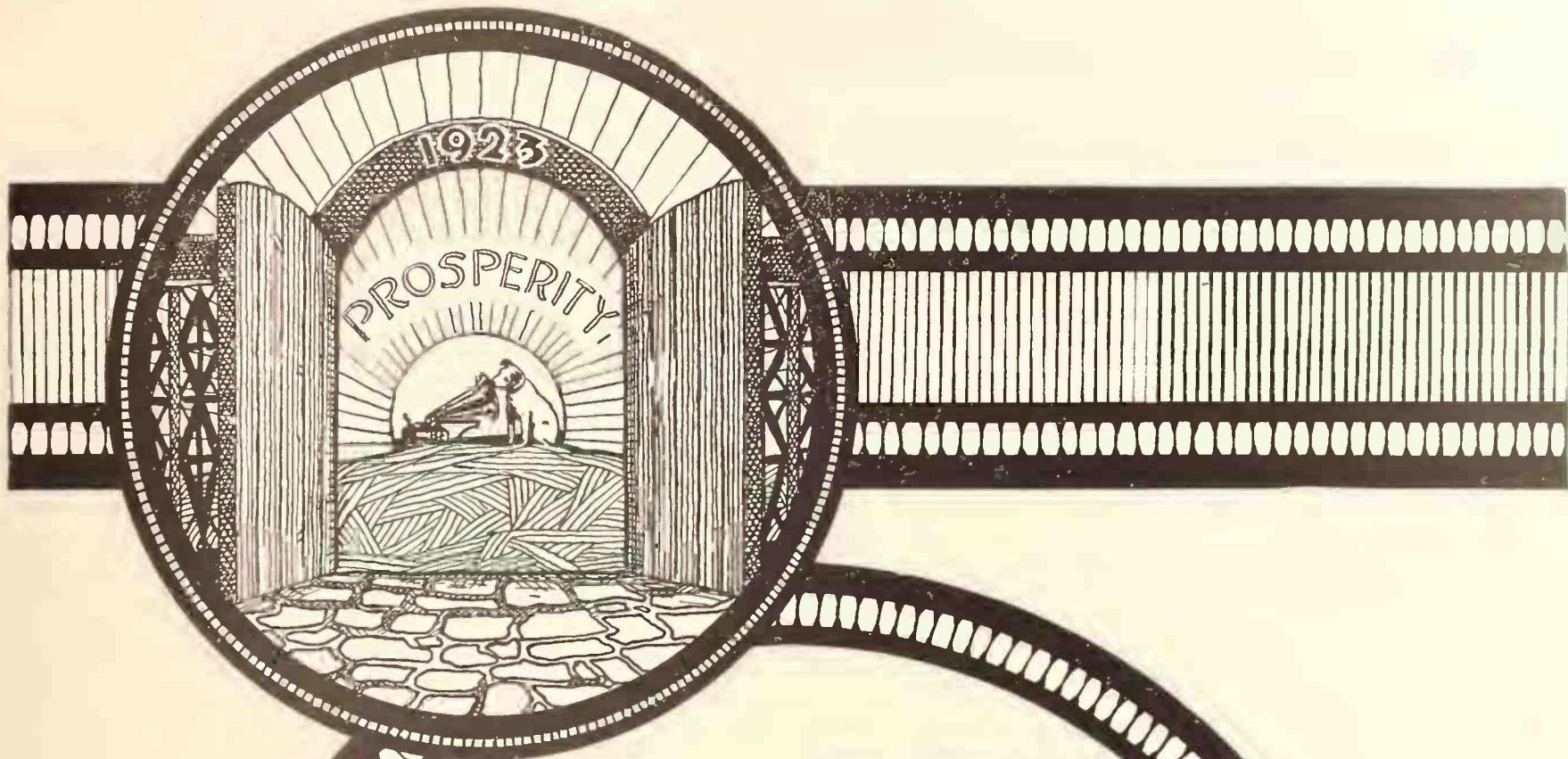

1923

“Prosperity Means Work”

In every newspaper, in every magazine, everywhere, all over, we read of prosperity being an accomplished fact. That’s all fine; it is most encouraging; sounds good and is good; but, Mr. Victor Dealer, this doesn’t mean that the public is going to “rush” your doors to buy your wares, pay a premium for service, graciously ask your consideration, and it certainly doesn’t mean that you can “rest on your laurels”. Don’t be lulled into a false sense of security.

1923 means a “work and toil” year—not only in the United States, but the world over. 1923 is the year of opportunities and possibilities—reminds us of any other year—and we say that whatever you put into it, just that much will you take out—not any more, maybe less.

No disputing the fact,—the New Year opens up a rich, wide field—virgin soil, so to speak—and promises every Victor Dealer in return for diligent, honest and conscientious labor a full and bountiful harvest.

What does 1923 hold in store for you, Mr. Victor Dealer?

C. BRUNO & SON, Inc.
351-353 Fourth Ave., New York

Victor Wholesalers to the Dealer Only

INDIANAPOLIS

Question of Terms Agitates Trade Circles—Billboard Advertising Pays—New Sonora Accounts—H. A. Brown Quits Pearson Co.

INDIANAPOLIS, IND., January 6.—Talking machine dealers of this city generally enjoyed the best holiday trade they have had in many years. The month of December for some of them was a record breaker. Machines at all sorts of prices and terms were offered. The demand was for medium-priced instruments.

The Question of Terms

The question of terms is one that is agitating the talking machine dealers as nothing else has done in many months. As was noted in the Herald recently an effort was made among the Victor dealers to arrive at an organized understanding with regard to terms. These efforts failed with the result that Victor machines were offered throughout the latter part of the year on many varieties of terms. Some of the dealers eliminated interest charges while others maintained such charges.

Some of the dealers offering unusually low terms, whether in Victors or other lines, say they have been forced to do so because of the methods of competitors. Apparently the majority of dealers are opposed to the low terms, but their opposition has not borne fruit so far as a change of methods in the trade generally is concerned.

Prominent among the machines that have been sold only on regular terms are the Brunswick and Sonora. Dealers in these machines report a rapidly increasing business. They credit a large part of their increase in business to the fact that they have held aloof from special inducements in the way of special terms, particularly as represented by offers of ridiculously small and inadequate initial payments.

Selling on Quality Basis

Cheap terms comprised the selling point of an advertisement run in one of the afternoon newspapers by the Baldwin Piano Co. for the promotion of Brunswick sales. The advertisement read, in part: "Do you want a dollar down phonograph or a Brunswick from Baldwin's? Will you buy cheap terms or quality?" The advertisement was objected to by a number of competitors who appealed to the Better Business Bureau. The Baldwin Co. withdrew the ad, but featured the argument in the window.

C. P. Herdman, manager of the talking machine department of the Baldwin Co. store, reports that his December business exceeded that of December, 1918. Business was exceptionally good in Brunswicks, he says, although sales were materially increased also in Columbia and Windsor machines.

New Sonora Accounts Opened

A remarkably good business in Sonora machines throughout the State is reported by Edward L. Mayer, manager of the Sonora department of the Kiefer-Stewart Drug Co. He reports the following new agents: Sowders-Bolling Piano Co., Evansville; Coffin's Music Garden, Warsaw; Evans Bros., LaGrange; Timmons Bros., Sheridan, and L. G. McQuinn, Wingate. Several other agents are ready to sign up, he says, as soon as stock can be obtained from the Sonora factory.

H. A. Brown Resigns

H. A. Brown has resigned as manager of the talking machine department of the Pearson Piano Co. He had been with the company two years, during the most of which he managed the talking machine department. At the time the resignation was effective, January 1, he had not decided which one of several offers he would accept. Prior to his employment by the Pearson Co. he had been with the Kipp Phonograph Co., this city; Baldwin Piano Co., Louisville, and J. M. Fisher Co., Anderson. Mr. Brown is succeeded by F. A. Donovan, who has been in charge of the music department of the John Shillito Co., Cincinnati, during the last

two years. Mr. Donovan formerly was employed eleven years with the John Wanamaker Co. at New York and two years with C. J. Heppé & Son at Philadelphia.

Billboard Advertising Pays

"We had a wonderful December," says Walter J. Baker, manager of the Brunswick Shop. "Sales were 100 per cent better than last year, although we offered no special terms. We are not selling terms, we are selling phonographs." Throughout November and December Mr. Baker maintained a city-wide publicity campaign on Brunswicks through the medium of forty-six large billboards. This outdoor advertising supplemented a series of newspaper advertisements ranging in size from a quarter page to

half page. Increase of sales was shown in both records and machines with console models selling at \$150 and \$250 in the lead.

Advises Jobbers to Get Retail Experience

"It would do every jobber good to put in a few weeks on the retail floor," says Walter E. Kipp, of the Edison Shop. During the absence of W. O. Hopkins, manager of the Edison Shop, who is temporarily away from the business on account of health, Mr. Kipp has been compelled to oversee the business of the shop through the busiest part of the year. This was his first experience actually working the retail end of the phonograph business, although he had previously been in the wholesale end for twenty years.

"I know now that the jobber needs to learn through actual experience the trials and tribulations of the retailer," Mr. Kipp continued. "When the jobber leaves his desk and gets on the retail floor for a time he will be in a position to tell the factory what the retail dealer needs. I was always telling the retailer what to do when I was in the jobbing end and was

Over 200,000 Phillips Tone Arms

Now In Use

Join This Army of Satisfied Users



For Portables

No. 1 Tone Arm and No. 3 Sound Box

Lengths 6½ in. 7¼ in. 8¼ in.
Straight or throw back

Samples \$2.50 straight
\$2.75 throw back

Quantity prices on request

A high grade tone arm combination
at a low price



No. 2 Tone Arm and No. 3 Sound Box

Length 8¼ in. center to center
Straight or throw back

Loud, deep tone

Sample \$3.00 straight
\$3.25 throw back



No. 5 Octagonal Throw Back Arm

With New Improved Pivot on Throw Back
8½ in. and 9 in. in length

Samples \$5.00

Patented sound box.

THE WILLIAM PHILLIPS PHONO PARTS CORP.

Manufacturers of Tone Arms for Portable, Medium and High Grade Machines

145 West Forty-fifth St.

Cable Address: "Phonoparts"

New York City

not giving enough thought to what the retailers were telling me. Any jobber can learn a lot by putting himself in the place of the retailer for a few weeks."

Miniature Banks Help Trade

Mr. Kipp says the Edison business for December was ahead of that done in December of last year and was more than double what was anticipated before the holiday season set in. As a means of promoting business between now and Easter Mr. Kipp has purchased banks in the form of miniature talking machines. These are to be given to prospects to be used in saving money to apply on initial payments for a new machine. The key to the bank is held at the Edison Shop, but as soon as the required payment on a phonograph has been made the bank and key are presented to the customer.

Enjoy Record Trade

December proved to be the second best month experienced by the Starr Piano Co. during the five years that T. H. Bracken has been manager of the Indianapolis territory, accord-

ing to Mr. Bracken. Sales in all lines were largely increased, he reports, and were exceeded in the five years only by sales in December, 1918. The business of December, 1921, was doubled in the Gennett records.

Mr. Bracken says that the demand for the new Gennett records continues to increase steadily throughout the territory. He is enabled to fill orders exceptionally well through the fact that the laboratory at Richmond is only seventy miles from Indianapolis. It has frequently happened, he says, that records are manufactured to fill an order and are in the hands of the retailer on the same day as the order is given by the retailer. Mr. Bracken says he has known a retailer to have sold by night records that were ordered and were manufactured on the day of the sale.

All Lines in Demand

Business in December was better than anticipated, according to H. E. Whitman, manager of the Circle Talking Machine Shop. The shop sells Victor machines exclusively. The predominant demand has been for upright models, Mr. Whitman says, with the flat-topped console models favored over the old-style console type.

Sales of Columbia, Vocalion and the special Widener machines during December made that the best holiday month in two years, says W. G. Wilson, manager of Widener's Grafonola Shop. The machine demand was chiefly for console models, he reports.

"Our December business in both machines and records was well ahead of last year," says A. C. Hawkins, manager of the Indianapolis Talking Machine Co., Victor dealer. "We are very well satisfied, especially as the indications are that business will continue to be good during the next two months."

J. B. Ryde, of the Fuller-Ryde Music Co., reports that his business in Victor machines and records during December was practically the same as that during the previous December. "What we sold," he said, "was on terms that were right. We will not have to reclaim a lot of machines as we might have to do if we had tried to build up a bigger holiday trade by offering unreasonably low terms."

The Christmas business in Edison machines was far beyond expectations all through the month, according to H. G. Anderson, general sales manager of the Phonograph Corp. of Indiana, Edison distributor. All dealers are doing the best they can despite a shortage of stock, he reports.

F. L. SCOTT VISITS COLUMBIA CO.

Manager of Omaha Branch Visits New York Headquarters—Reports Good Business

F. L. Scott, Jr., manager of the Omaha branch, was a visitor recently to Columbia headquarters, New York. Mr. Scott reports that the demand for Columbia Grafonolas and records for the business holiday trade was exceptionally good. Despite the warm weather which has obtained in this territory and which was not conducive to a large holiday demand, Columbia dealers enjoyed a very fine business. The demand was for machines in the \$100 class and many of these were sold. All in all, Mr. Scott was very enthusiastic and well pleased with the results obtained in his territory. His plans were for a short stay at Columbia headquarters to talk over the campaign for 1923.

S. HARRIS OPENS VICTOR STORE

WASHINGTON, D. C., January 9.—A completely equipped Victor retail store will soon be opened in this city by Frank S. Harris, for a number of years general manager of the Cohen & Hughes wholesale Victrola house and one of the most prominent men connected with the trade in this territory. Mr. Harris will open his establishment in the Mt. Pleasant section of this city, one of the most promising and fastest growing sections hereabouts.



The point of a Sonora semi-permanent needle magnified many times after having played a number of records. Note the uniform shaft—a great saver of records.

"An Important Point"

in the policy of every retail store is the careful selection of small accessories. Not only are they the source of steady profit but they represent service without which your customers are dissatisfied.



Semi-Permanent NEEDLES

are a real addition to the enjoyment of the phonograph, eliminating trouble, time, and annoyance in operation. Sonora Semi-Permanent Needles are good for fifty or more records each, and they never score the record grooves.

Sonora Phonograph Company, Inc.

GEORGE E. BRIGHTSON
President

279 Broadway New York

Canadian Distributors:
Sonora Phonograph, Ltd., Toronto

Radio and phonograph combined in the LYRADION—your customers will prefer this line

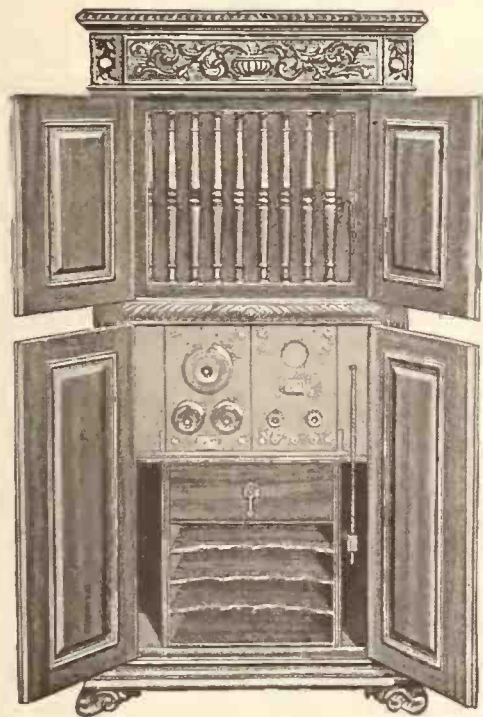

Lyradion Italian Renaissance

Combination radio and phonograph. A beautiful hand-carved cabinet in polychrome finish for large homes and clubs. Wired for Westinghouse "set" or complete with Lyradion 5 stage non-regenerative set. All instruments and batteries completely housed.

Radio enthusiasts are expressing their preference for the Lyradion line of attractively housed radio sets in no uncertain terms. While the lady of the house has tolerated the old method of placing batteries and sets on the library table and floors as a matter of necessity in the past, she is now demanding the attractive Lyradion combination radio and phonograph completely housing instruments and batteries and offering dual and perpetual entertainment features. Besides these attractive cabinets harmonize with the furnishings of the modest as well as the most luxurious home surroundings.

The wonderful Seabrook amplifying horn used on all models is responsible for the remarkable reproducing qualities of Lyradion instruments. This horn employs entirely new principles of sound reproduction which are fully protected by basic U. S. patents.

Lyradion cabinets can be furnished wired complete for Westinghouse two-stage R. C. sets or with Lyradion five-stage non-regenerative receiving sets.

Territory is being rapidly allotted—dealers or jobbers should write or wire immediately for proposition.

Lyradion Manufacturing Co.
Mishawaka, Indiana
KENYON W. MIX, Director



New Emerson Performance

Excels New Emerson Promise

The *new* Emerson Phonograph Company, with an absolutely new organization and personnel, is manufacturing a *new* Emerson Phonograph and a *new* Emerson Record.

Emerson Records

The Emerson Company is producing a new Emerson Record, new in quality, musically, mechanically and phonographically, retailing at seventy-five cents under the name "Emerson". This record is, we wish to state in the most emphatic manner possible, the only record which this company is directly or indirectly manufacturing or is directly or indirectly interested in.

Emerson promised you a few months ago that the new Emerson Records would be tuned to the demands of the public as never before. Musically, artistically, and from the standpoint of entertainment, they were to be masterpieces. **THEY ARE.**

We promised the dealer a 20% extra profit on each record sold. This promise is fulfilled.

Emerson Phonographs

*A line of period phonographs trademarked
with the well-known Emerson name*

Emerson promised list prices substantially less than other *standard trademarked* lines; a quality of reproduction, cabinet work, finish and construction unexcelled; a discount to the dealer much greater than the standard discount.

The new Emerson performance has verified to an unexpected degree this promise.

Emerson Phonograph Co., Inc.
105 West 20th St. New York



Emerson Louis XV Model

IN PITTSBURGH

Old Year Closes With Big Sales Volume—Optimism Marks Opening of New Year—Fire Destroys Large Edison and Columbia Stock

PITTSBURGH, PA., January 8.—With an exceptionally brisk holiday season just ended the talking machine dealers of Pittsburgh and vicinity are looking forward to the year 1923 with unalloyed optimism and confidence. The general indications for business are good. The industrial situation was never better and gives promise of long-continued activity. This is especially true of the iron and steel mills, which have booked sufficient orders to keep the plants busy for months ahead.

Another important factor that points toward "good times" is the report of the Retail Credit Men's Association of Pittsburgh, which indicates that the amount of business done the past month (December) by Pittsburgh retail stores was unprecedented in volume. The outlook for the coming year also was voiced as indicating continued prosperity on account of labor being well employed, with bills being met promptly on the part of those having charge accounts in the stores, or more especially in accordance with the terms of sale.

Brisk Columbia Sales

S. H. Nichols, manager of the local offices of the Columbia Co., said to The World representative: "Our business for December was very good in Columbia Grafonolas and records and our staff is highly pleased with the result of its work with the various dealers whom we serve. I am looking forward to 1923 with keen anticipation as I believe that our business will be larger than ever. The busy mills and factories are bound to stimulate businesses of all kinds and in this the Columbia dealers must necessarily share. We are making plans to be of greater service to our clients, if that is possible, in the next twelve months."

John Henk, the well-known proprietor of the Columbia Music Co., Columbia and Edison dealer, states that the month of December was an unusually good one and many of the more expensive Columbia and Edison models were disposed of.

Victor Dealers Optimistic

T. E. Shortell, manager of the Victrola department of the S. Hamilton Co., said: "Our business for the past month, especially in consoles, was excellent. Sales of records also were above the average for December and I am now looking ahead in anticipation of an excellent Victor business."

George H. Rewbridge, manager of the wholesale Victor department of the W. F. Frederick Piano Co., stated that the year just closing was one in which the best volume of sales was recorded in the final months. He said: "The sale of Victrolas has been very good, especially the console models. In fact, it was difficult just around the holidays to secure the kind of machines that were wanted. I am more than confident that 1923 will be a good business year for the Victor dealers who are alive to the opportunities and possibilities of the Victor merchandising system." Mr. Rewbridge has new offices, two stories higher up than formerly, in the Frederick Building. The former offices are to be converted into a shipping room. The new quarters are large and airy and from the windows a good view of the river and Northside sections of the city can be seen.

Demonstrates Health Records

The Standard Talking Machine Co., Victor distributor, conducted an interesting demonstration of the Victor health records before the Rotary Club, of Pittsburgh, at the December meeting when it was the turn of J. C. Roush, president of the company, to provide for the program of the club. A woman demonstrator gave an exhibition of the value of the records following a brief health talk and the one hundred and fifty members present were much in-

terested in the various exercises. The Standard Co. has furnished women demonstrators to dealers since these records were first introduced.

Shortage Curtailed Sales

Edward Hoffmann, of the J. M. Hoffmann Co., Brunswick phonograph dealer, stated that the holiday sales of Brunswick machines and Brunswick records were very large and that he felt that the firm could have disposed of many more instruments had certain models been available in time. Mr. Hoffmann said that he felt sure that 1923 was bound to be a prosperous period for the trade.

Police Head Presented With "Talker"

Police Commissioner John P. Clancy, of the Oakland district, this city, was presented with a Victrola and a number of records as a New Year's gift by the men under his command. The presentation was made at roll call and the commissioner, taken by surprise, heartily thanked the policemen for the gift. Each of the policemen contributed a like amount to pay for the instrument.

Flames Destroy Edison Stock

The pharmacy of J. E. Bumbers, of Swissvale, a suburb of Pittsburgh, was practically destroyed by fire recently, causing a loss of \$28,000. Mr. Bumbers handled the Edison phonographs and Columbia Grafonolas and had his entire stock of machines and records wiped out. Mr. Bumbers, who carried partial insurance, has opened a new place of business nearby.

President Goldsmith on Trip

I. Goldsmith, president of Player-Tone Talking Machine Co., accompanied by M. S. Levenson, secretary of the company, left for Grand Rapids on a brief business trip. Mr. Goldsmith, in referring to business conditions, said: "Our holiday trade was exceptionally brisk and we are looking forward with keen interest to the coming year. As a starter for good business the first shipment of Player-Tone talking machines for the new year totaled a carload."

Messages of Cheer

Thomas T. Evans, manager of the wholesale Victor department of the C. C. Mellor Co., stated that he was delighted with the volume of business handled by the department for the closing months of 1922 and is of the opinion that there will be no limit to the business of marketing Victrolas and Victor records for 1923, provided the present excellent industrial conditions prevail.

Fred Drake, manager of the retail Victor department of the W. F. Frederick Co., emphasized the fact that the firm beat all sales records for December when the books were audited for the past month. Mr. Drake spent the Christmas holidays with his family in Elmira, N. Y., and on his way back to Pittsburgh stopped off in New York City.

R. R. Myers, manager of the Victrola department of Spear & Co., reported a marked increase in his Victor sales for December. He is quite optimistic relative to the outlook for business conditions in the next three or four months.

C. R. Parsons, the well-known manager of the Rosenbaum Co.'s talking machine department, stated that the "Christmas season trade was the best that we ever experienced." Mr. Parsons is firmly convinced that the Spring business in talking machines and records will be better than for the same period last year. The Victrola, the Pooley and the Sonora instruments are handled.

New House Nearing Completion

A. R. Meyer, manager of the Joseph Horne Co.'s talking machine department, dealer in Victor, Cheney, Pooley and Columbia machines, stated that the December business was excellent. Mr. Meyer anticipates that he will be ready by February 1 with his department lo-

cated on the balcony of the new building which is rapidly nearing completion. It will be a model of its kind and will have fifteen large demonstration rooms.

Year Closed With Fine Edison Demand

The Buehn Phonograph Co., Edison distributor, closed an excellent 1922, augmented by an exceptional December demand, according to A. A. Buehn, treasurer.

News Gleanings

Marion Cheney, of the Cheney Phonograph Co.'s local offices, is now in exclusive control of the phonograph department. Okeh records will hereafter be sold by the General Radio Corp. Mr. Cheney stated that sales of the Cheney for the past month were most gratifying.

E. G. Hays, president of the E. G. Hays Co., Brunswick dealer, spent several weeks at Asheville, N. C., playing golf. He will return there later for a longer stay.

The Frank & Seder Co. has discontinued its Columbia department and in the future will confine its efforts to records only.

Is Your Bubble Book Stock Complete?

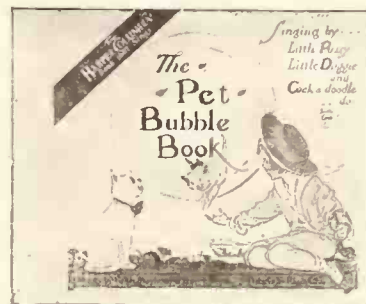

BUBBLE BOOKS

Repeat orders will follow your Christmas Sales. Have you the complete series as follows?

- No. 1
THE NURSERY BUBBLE BOOK
- No. 2
THE MOTHER GOOSE BUBBLE BOOK
- No. 3
THE SINGING GAME BUBBLE BOOK
- No. 4
THE ANIMAL BUBBLE BOOK
- No. 5
THE PIE PARTY BUBBLE BOOK
- No. 6
THE PET BUBBLE BOOK
- No. 7
THE FUNNY FROGGY BUBBLE BOOK
- No. 8
THE HAPPY-GO-LUCKY BUBBLE BOOK
- No. 9
THE MERRY MIDGETS BUBBLE BOOK
- No. 10
THE LITTLE MISCHIEF BUBBLE BOOK
- No. 11
THE TIPPY-TOE BUBBLE BOOK
- No. 12
THE GAY GAMES BUBBLE BOOK
- No. 13
CHILD'S GARDEN OF VERSES BUBBLE BOOK
- No. 14
THE CHIMNEY CORNER BUBBLE BOOK

Hangers, window cards, and circulars supplied to Bubble Book dealers.

Write for our complete catalogue of Standard Phonographs, Cabinets and Accessories.

The Cabinet and Accessories Co., Inc.

Otto Goldsmith, Pres.

3 WEST 16th ST., NEW YORK
Telephone Watkins 2777-2778

Made of High Grade
Hardened Steel
Specially Treated
to Give
Frictionless Surface

Reg. U. S. Pat. Off.
No. 995758 which will
be strictly enforced

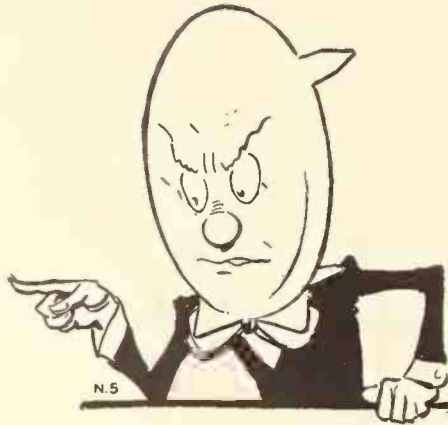

Extra Heavy
Size—1 1/8 in.



3/8 in.



1/4 in.



1/8 in.



1/2 in.



3/8 in.

Furniture Footwear That Will Not Get Out of Order

A device for furniture leg bases should be made so that it will not get out of order.

DOMES of SILENCE

"Better than Casters"

once on furniture stays and lasts the life time of the furniture and will not get out of order.

"DOMES of SILENCE" have these added qualities, which ordinary devices do not possess:

- Economy*
- Simplicity*
- Silence*
- Invisibility*
- Adaptability*—Suitable for covered and uncovered floors alike.
- Service*— Long wear.

Gives protection to furniture, floors and rugs and are the perfect footwear for furniture—

DOMES of SILENCE *Division*

Henry W. Peabody & Co.
17 State Street, New York City

In All Your Talking Machine Orders,

Specify DOMES of SILENCE

"Better than Casters"

P-210

*What we say above about Furniture applies also
to Phonographs*

The Trade in **BOSTON** *and* **NEW ENGLAND**
 JOHN H. WILSON, Manager
 324 WASHINGTON ST., BOSTON, MASS.

BOSTON, MASS., January 8.—Stock taking is now the order of the day. Everyone is working over figures and they say, you know, that figures don't lie. The year's business on the whole is generally admitted to have been good, but what has satisfactorily evened up things was the business of the last few months of 1922. Just what the new year holds forth is yet to be determined. Roger W. Babson, the statistician, who has several times been quoted in this department, says that there is good business ahead but it won't be in the nature of any boom, and that there are further readjustments yet to be made. Mr. Babson has just returned from a country-wide tour and has studied conditions first-hand and conferred with industrial leaders. One interesting observation of his is worth quoting: "High prices do not make prosperity. Marking goods up does not add to the total wealth of the country. Basically, prosperity is dependent upon production and conditions in this field are encouraging. Almost without exception production during 1922 was greater than during 1921."

New England Trade Luncheon Meeting

The New England Music Trade Association held an impromptu luncheon at Cook's Restaurant in the heart of the music district on Tuesday and had for its special guest C. M. Tremaine, director of the Bureau for the Advancement of Music, who came over from New York on purpose to talk to the members, over whom William L. Nutting presided. Mr. Tremaine spoke of the value of co-operative advertising and gave some informing facts to the members as to healthy ways to add to the membership of the organization. Another guest was E. W. Preston, advertising director of the Boston Herald, who also spoke along the same lines. A committee was formed to prepare plans for a big Association function some time in February and this committee consists of R. O. Ainslie, Harry Spencer, William Merrill, who is the secretary of the Association; Burton R. Miller, Roger Brown and D. D. Luxton. The Copley-Plaza will probably be the scene of the affair.

Pleased Over Columbia Business

Fred E. Mann, head of the New England department of the Columbia Co., is highly pleased over the business for 1922, although, as he says, much of it came during the months of September, October, November and December. The

wind-up, however, was splendid. He says his department is now getting together its figures, which ought to show up well. "We are heading toward a good normal business," declared Mr. Mann. "There is not likely to be anything phenomenal about it, but it will be a healthy, steady growth and in the long run should make a most satisfactory showing."

Fine Window Displays

All the talking machine shops were tastefully "dressed up" for the Christmas holidays, but some of them did not decorate quite as early as usual. M. Steinert & Sons, who have a large window admirably adapted to a pictorial display, used a profusion of laurel, fir and pine cones with the center of interest a jolly-looking Santa Claus coming down in an airplane. The Arch street store had a very pretty window wherein a snow effect was conspicuous. The C. C. Harvey Co. had a very large wreath at the rear of the window, while the interior of the warerooms was festooned with ropes of laurel which centered in a large star which was electrically lighted. Both Henderson stores on Boylston street were filled with the atmosphere of Christmas and other places in Music Row that had their windows appropriately decorated were the Oliver Ditson Co., Tremont street, in which decoration the brilliant red poinsettias played an important part; the A. M. Hume Music Co., Aeolian Hall, which looked unusually artistic, and Vose & Sons.

M. Steinert & Sons' Christmas Party

M. Steinert & Sons as usual had a delightful Christmas party at the Arch street store in which the big factors were Bob Steinert and Kenneth Reed, who saw to it that everyone had a good time. At one end of the big room on the third floor, where Messrs. Steinert and Reed receive their visitors in their respective private offices, a very good imitation of a red brick fireplace had been arranged and there was a very amiable Santa in the person of John Mahoney. There were gifts for everybody, a fine supper was served, there was dancing, and an entertainment in which Shad Plenty, the versatile elevator man, played his usual part, but his act had to be run off early as he had a professional engagement that called for his services elsewhere. Miss Grace Crosby contributed some ballads and Miss Ethel Walsh gave some Irish folk dances. A group of the

young women of the establishment, headed by Miss Crosby, constituted the committee that arranged the details of the party, which was one of the most successful ever held.

An Optimistic Message

The Eastern Talking Machine Co. is well pleased over the results of the 1922 business, and both Herbert Shoemaker, the general manager, and E. W. Killgore, the sales manager, are confident of a splendid 1923. Mr. Shoemaker thus expresses himself:

"Nineteen twenty-three, from present indications and what we can see of the future, looks to be the banner year in the talking machine industry. The idea of music in the home is becoming more general than it has ever been, and there is more publicity directed at this in the national press than ever before. It is just a question of the ability of the retail merchant to be keen enough to see this and capitalize the work which is being done for him by the press. The talking machine market is rapidly becoming stabilized and the financial condition of the companies now in the field is greatly improved, and for this reason the industry is on a firm and stronger basis than it has been for some time in the past."

E. W. Killgore Reviews Prospects

Mr. Killgore, in briefly reviewing the business toward the close of 1922, said that Christmas buying on the part of the public demonstrated one thing. "Quality and not price," he said, "was the determining factor. Nationally advertised products were sought after, and for this reason Victor dealers experienced the biggest business in their history. Nineteen twenty-three is a question mark. From all indications it should be a wonderful year for the retailer. The announcement of the new model Victrolas was timely and gave a big boost to Christmas buying. The demand could not be supplied and naturally a great deal of buying had to be diverted to 1923. The cumulative effect of the machines sold and now in homes will be great. Each one will be a booster for the machines to come. This, coupled with the national advertising of the Victor Co., should make 1923 a wonderful year."

Banner Victor Sales

Kenneth Reed, wholesale manager of M. Steinert & Sons, is highly enthusiastic over the
 (Continued on page 84)



A Year of Opportunity

Victor dealers have entered upon a new period of business development and expansion, with a promise of a healthy trade for months to come. The bulk of the business will come to those dealers who maintain complete stocks and observe energetic merchandising methods.

Ditson Service Will Help You in These Two Essentials

CHARLES H. DITSON & CO.
 NEW YORK

OLIVER DITSON CO.
 BOSTON

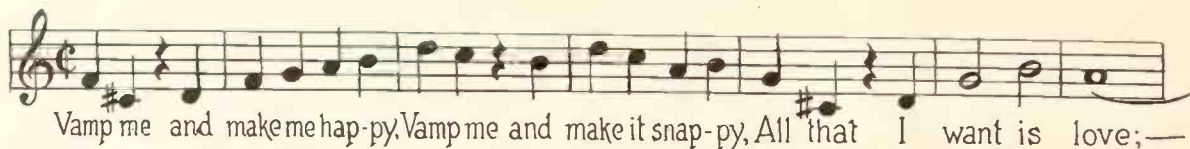

Vamp Me

The New Fox-Step
by the Writer of 'The Vamp'

"You can't go wrong
With any FEIST song"



THE TRADE IN BOSTON AND NEW ENGLAND—(Continued from page 83)

good showing that the company made during 1922, when the last few months in particular were almost phenomenal in the volume of business done. "We are looking for a banner year," said Mr. Reed in speaking of the new year on which the trade has already entered, "and there is every indication that the Victor product will benefit to a tremendous extent. Stocks are in good shape everywhere and the action of the Victor Co. in eliminating dead sellers has proved a wise move and dealers are in better condition than in years to meet the demands of 1923." Mr. Reed plans to start for the Victor factory within the next ten days. He states that the Eight Famous Victor Artists will be around Boston in March, which is good news to the many admirers of the famous organization.

Big Business at Vocalion Hall

Manager Birdsall, of Vocalion Hall, reports a very good business in the Vocalion, Brunswick, Edison and Victor machines during December and especially during the last fortnight before the holiday. Daily the handsome store was quite filled with patrons. Mr. Birdsall is looking for a good year and it is his opinion that business is going to move forward with increased momentum as the months of 1923 roll on. Tom Pritchard, the auditor from the

New York office, made a flying trip to Boston toward the end of the month.

Ditson Forces Make Merry

Henry Winkelman, head of the Victor department of the Oliver Ditson Co.; Otto Piesendell, his able right-hand man, and the rest of the Victor staff were among the large company that enjoyed the Christmas festivities of the Ditson house, held a few nights before Christmas in the Ditson building. There was a supper, Christmas tree, dancing and a good program, to which the Ditson talent contributed. A letter from Charles H. Ditson, which was read by Clarence A. Woodman, that worthy New York gentleman, made the happy announcement that it had been decided to give the employes a bonus, a bit of news that was received with great applause and three cheers and a tiger for Mr. Ditson.

Completing Name-Change Arrangements

Joseph Burke is most enthusiastic over the business that was done in the Sonora line during the month of December. Big as was the output for this and the preceding months it might have been larger had there been machines enough to supply the demand. It was a case of where the Sonora Phonograph Co. of New England, as the old Musical Supply & Equipment Co. here is now known, could not take

care of the business as it would have liked. All the details of the transfer incident to the change of name have not yet been effected and Mr. Burke is going over to New York in a few days to complete the arrangements. The new company will probably be incorporated under the laws of Massachusetts at an early date. John G. Pringle, assistant to the sales manager of the parent Sonora Co., who was here for several weeks, has returned to New York.

Window Display Pointers

In the seventh issue of the Hallet & Davis Salesman there is an article with an illustration under the caption "Window Display That Sold Twenty-one Hallet & Davis Phonographs in One Week," the story being about the success of Clark Wise & Co., of San Francisco, Cal. In the text this company explains what are the three cardinal points toward a successful window display and here is what is said:

"To accomplish a satisfactory selling window, particularly a phonograph window, the first thing to be considered is what the prospect wants to be shown. This can be accomplished without overcrowding the display.

"The second consideration is a strict adherence to style. That is to say, the window display should be in keeping with the character of the designs represented in the display. The tendency is generally to over-embellish. This common fault should not prevail. It is injurious to the display. Over-embellishment will always overpower the main theme of your window display idea. It detracts from the merchandise displayed. A careful study of the proper color schemes is advisable. There should be no strong contrasting colors in the scheme. Keep the color scheme in low, soft tones. A tasteful blend of colors involved is helpful in that it acts as a background alone—making the merchandise stand out with more definite yet pleasing emphasis.

"The last of the cardinal points in a successful window trim is the reading matter. This is very important. After all is said and done, the lasting impression is made by what is said about the merchandise displayed. Give the prospects something to read that's interesting. The show cards should be so carefully worded as to make an impression that both pleases and lasts. Tell them what is behind the merchandise displayed—how long the factory has been in business, how they have gained their success. There are many other points to be considered in planning and executing successful window trims, but these above mentioned are, without argument, the most important."

Increases Shipping Facilities

The Eastern Talking Machine Co., badly in need of increased record and shipping facilities, has removed its series of Unico booths which were installed a few years ago by the Unit Construction Co. and it has sold the whole outfit to H. L. Baker, who operates the Hyannis

KRAFT-BATES AND SPENCER INC.

NEW ENGLAND DISTRIBUTORS

A Brunswick dealer is always rather proud to carry the Brunswick line. This condition is the result of a calculated business policy.

A Brunswick dealer knows that every Tom, Dick and Harry does not sell the Brunswick. He knows that this policy gives the authorized Brunswick dealer less competition in the Brunswick line and none of the unscrupulous price-cutting competition which is the bane of the phonograph business today.

We, on our part, are rather proud of the fact that we have never compromised sound business principles and have always protected Brunswick dealers 100%. It was not long ago that 15,000 obsolete Brunswicks were withdrawn from dealers and rebuilt to protect those dealers who had stocked the model which was being discarded.

As a prestige builder as well as a profitable business builder, you will find the Brunswick unequalled in the field today.

KRAFT, BATES & SPENCER, Inc.

1265 Boylston St. Boston, Mass.

New England Distributors

Steel Needles Motrolas Record Brushes Khaki Covers

THE TRADE IN BOSTON AND NEW ENGLAND—(Continued from page 84)

Music Store, at Hyannis, down on Cape Cod, which, by-the-bye, is one of the most successful stores of its kind in that section of the State. Mr. Baker has just moved into a new location so that this installation fits into his scheme very acceptably.

Herbert Shoemaker Loses Mother

Herbert Shoemaker, general manager of the Eastern Talking Machine Co., has the sympathy of a host of friends in the loss of his mother, Mrs. J. L. Shoemaker, who died at her home in Overbrook, outside of Philadelphia, toward the middle of December. Mr. Shoemaker's father, it will be recalled, has been quite sick for a considerable time past.

Barite Co. Opens Branch

The Barite Talking Machine Co., which operates a Victor shop at 246 Boylston street, has opened a branch store at 95 Summer street, which is in the neighborhood of the South station and in a much-traveled district. Mrs. Etta Barite Reinherz is head of the company.

Attends Victor Sales Conference

James Frye, Victor representative in this territory, spent three days at the Victor factory toward the end of December in attendance at the sales conference.

Presents Gifts to Dealers

The Eastern Talking Machine Co. remembered its dealers with a very useful gift which was in the shape of a large leather wallet enclosing a group of large manila envelopes to hold all kinds of valuable papers, such as wills, life, health, accident, burglary, automobile and fire insurance, deeds and mortgages, stocks and bonds and, finally, an envelope for miscellaneous papers. The printing on the outside cover includes the name of the Eastern Talking Machine Co. in gold letters.

Addition to Vocalion Hall Staff

An addition to the staff of Vocalion Hall in Boylston street is Miss Hazel Carll, who has been in the employ of a downtown store. She is attached to the record department.

Congratulations

It's a girl and weighs nine pounds. All the Victor trade has been awaiting with interest this new arrival in the household of John Mahoney, of the sales staff of the Arch street store of M. Steinert & Sons Co. This second child in the Mahoney family arrived last Thursday afternoon and all of Johnny's friends are smoking real expensive cigars—on him, of course.

H. L. Pratt a Visitor

H. L. Pratt, manager of the branch service department of the executive division of the Columbia Co., came over to Boston with his

family to spend the holidays with his wife's people. He enjoyed himself immensely.

Local Kane Furniture Co. Branch

Jack Kane, of the Kane Furniture Co., of Woonsocket, R. I., is in town to-day for the opening of the new Kane store at 740 Washington street. This is the first time that this concern, which operates several stores, has made its appearance in Boston. In its Woonsocket store the Columbia line of talking machines as well as records are carried.

F. C. Collins to Wed

Frederick C. Collins, traveling salesman for the Connecticut and southern Massachusetts territory of the Columbia Co., is going to be married on January 10 at New Haven, and his best man is to be H. J. Kennedy, manager of the Widener store at Worcester. No information has been given The World correspondent as to the identity of the bride.

To Confer on Brunswick Production

Harry Spencer has hopped off to Chicago to talk to the home office officials about the 1923 output of the Brunswick Co. As he couldn't get accommodations out of Boston going West he had to book from New York. He will be away two weeks. One learns of two new Brunswick models which are to become quite popular this season, both of them of the console type, the new Tudor and the York. The first of these that have arrived on the scene have been eagerly picked up by discriminating dealers. The Brunswick business in the local field has been very satisfactory.

L. W. Hough Convalescing

L. W. Hough, of this city, New England representative of Peerless record albums and Long cabinets, is convalescing from a period of illness running back as far as last November. Mr. Hough numbers many friends throughout the trade and although confined to his bed during the pre-holiday season Mr. Hough states that business continued good and many orders throughout his territory were received by mail, both by him and by the houses he represents. At the same time Mr. Hough has been the recipient of many greetings and well wishes from his many friends for a quick recovery. Mr. Hough is well on the road to his usual good health and expects to be on the job again in a very short time—in time, as he states, to make 1923 the biggest year in his business history.

Budget of Columbia News

The latter part of December was celebrated by a double wedding in the ranks of the Columbia dealers; Jack Albert and Jessie Newman, both of the F & F Talking Machine Co., Fall

1923
Will Bring
What You
Go After

Exclusively



Wholesale

The Eastern Talking
Machine Co.

85 ESSEX STREET
BOSTON MASS.

River, Mass., being married the same time as Miss Newman's sister. Mr. and Mrs. Albert were in Boston during the honeymoon, visiting the Columbia wholesale branch.

Alex. Winograd, Columbia dealer in New Bedford, recently made a rather unusual sale of a Grafonola G-2 in mahogany to a woman who thereby purchased her seventh Columbia Grafonola. The other six had been given to her six children on their respective marriages, but as there are no more children she is planning to keep the seventh Grafonola for herself.

The F. N. Joslin Co., of Malden, Mass., Columbia dealer, recently sold a D-2 Grafonola with two dozen records to a missionary, leaving

(Continued on page 86)

“Perfection” Edison Attachments
and
“Perfection” Reproducers

The “Perfection” Flexi-Tone Edison Attachment (No. 4 and No. 7) as illustrated, attached to all types of Edison Disc Machines, makes the most perfect attachment available for playing all makes of lateral cut records requiring steel, tungstone or fibre needles. Only first quality mica diaphragms used in “Perfection” reproducers, giving clear, natural tone. The horizontal ball-joint and direct uplift construction give freedom of movement so that attachment may be used with or without lever, giving excellent results.

Retail price, \$9.00 Gold. \$8.00 Nickel.

The “Perfection” Pur-I-Tone Edison Attachment (No. 6 Universal) plays all makes of records on New Edison Disc Machine.
Retail price, \$10.00 Gold. \$9.00 Nickel.

The “Perfection” Edison Attachment (No. 4 and No. 2) plays all makes lateral cut records on New Edison Disc Machine.
Retail price, \$7.00 Gold or Nickel.

NOTE—Special Discounts to Dealers, also Quantity Prices on Request

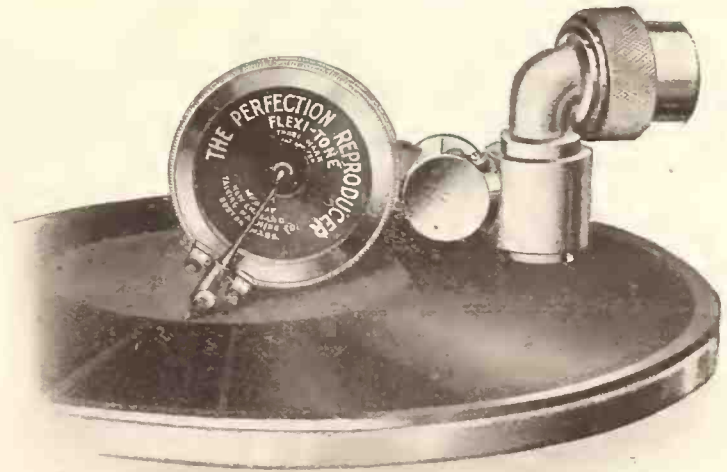

New England Talking Machine Co. 16-18 Beach St., Boston, Mass.



BEEES

A Busy Bee Fox Trot
by **Ray Lopez and Ted Lewis**

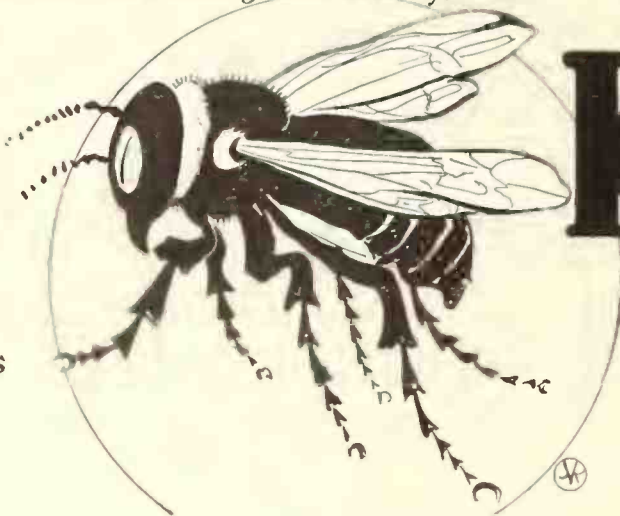

KNEES

"You can't go wrong
With any FEIST song"



GLEANINGS FROM THE BOSTON TRADE

(Continued from page 85)

shortly for South Africa to be away a period of seven years.

E. C. Edwards, outside man for Wheeler's Pharmacy, Claremont, N. H., Columbia dealer, uses the Magnavox to excellent advantage to interest the crowds who attend the weekly concerts in town. The Wheeler establishment is directly on the Square, where the concerts are held, and the use of the Magnavox with Columbia records not only keeps the crowds in good humor, but stimulates the sale of records.

Scores in Poetical Essay

Mrs. Anita B. Ayler, Newport, R. I., was awarded \$100 by the Boston Sunday Post for a poetical essay, in which she paid tribute to the merits of the Brunswick phonograph.

NEWSPAPER FEATURES OKEH RECORDS

BOSTON, MASS., January 4.—The Boston American, in order to supplement the advertising

done in its pages by a showing of the genuine article, arranged recently for a display of Okeh records that attracted considerable attention. This window, which is shown herewith, was the center of attraction for over a week, hundreds of passers-by stopping to examine the display carefully. Local Okeh dealers reported a noticeable increase in sales during the week of the display.

TO DIRECT VOCALION RECORDING

Harold Sanford Succeeds T. P. Ratcliff as Director of Standard and Operatic Recordings for the Vocalion Records

Harold Sanford, well-known violinist, has assumed charge of the standard, operatic and classical recordings at the Vocalion Recording Studios, succeeding T. P. Ratcliff, who resigned recently to take charge of the marketing of a new line of health records. Mr. Sanford was for many years associated with Victor Herbert as arranger, has played with leading orchestras,

and was for a time orchestra conductor for the Emerson Phonograph Co.

TED LEWIS AND BAND ENTERTAIN

Exclusive Columbia Artist Plays for War Veterans—Also Gives Successful Radio Concert

CLEVELAND, O., January 6.—Through the cooperation of the Greenwich Follies and the



The Ted Lewis Orchestra

Cleveland Studebaker branch, the patients of the Marine Hospital were given a big treat recently. Ted Lewis and his band, exclusive Columbia artists, appeared recently in this city with the Greenwich Village Follies and he gladly consented to entertain the veterans at the hospital. The rest of the company also wanted to do their bit and the local Studebaker branch furnished the transportation without charge.

Through the courtesy of the Cleveland Plain Dealer and the Union Trust Co. radio fans in this vicinity were also entertained by Ted Lewis during his stay here. Accompanied by his band, Mr. Lewis gave a radio concert at the Union Trust Co.'s broadcasting station which was enjoyed by 50,000 radio fans. So great was the interest in the concert that repeated telephone calls came into the laboratory during the performance asking for the many old favorites which Ted Lewis had made popular on Columbia records.

The firm of Lozier & Gandy, dealers in electrical equipment, La Grange, Ga., have dissolved partnership and in the near future C. W. Smith and Mr. Lozier will open a music store with a complete stock of talking machines and records and musical instruments. The establishment will be admirably fitted up.



A Striking Okeh Record Display Made by the Boston American

Record Manufacturers—This Year, Start Right

Let quality be the first consideration in your purchase of raw materials. Do not be swerved from this course by price alone.

The shrewd buyer is not the one who always buys the lowest priced materials. He is the one who buys the best materials at a fair price, thereby obtaining the most value for his money.

Have You Tried Our Cotton Flocks?

CLAREMONT WASTE MFG. CO.

Claremont, N. H.

Repair Parts and Main Springs

- Double-spring Motors.....\$ 3.25
- Liberty Motors 6.00
- Three-spring Motor 12.50
- Four-spring Motor..... 15.00
- Tone Arm and Sound Box, per set,
\$1.35 and up

WRITE FOR CATALOG

PLEASING SOUND PHONO. CO.

204 E. 113th St. New York, N. Y.

DENVER

Annual Knight-Campbell Sales Conference—All Merchants Report Tremendous Sales Volume

DENVER, COLO., January 4.—Whether Denver residents received more Christmas gifts of money than ever before and decided to spend it buying musical instruments or if there is another reason, the fact remains that the week following Christmas Denver music dealers reported a remarkable run of business. In fact, one sales manager said his house did almost as much business the week after Christmas as it did the week before. Sales of talking machines by local dealers for the month of December broke all records and it is certain that Old Man Prosperity is back on the job. From the number of machines delivered there must have been few homes without music on Christmas Day. Salesmen worked far into the night Saturday and even Sunday to get the instruments right where they could be heard in Denver homes on Christmas morning.

One of the outstanding meetings of the week following Christmas was the sixth annual sales conference of the Knight-Campbell Music Co., December 27-29, with more than a hundred in attendance. The outstanding features of the program were the sales demonstrations, in which one salesman sold to another salesman, the latter acting as the customer and bringing up all the objections to the instrument met in the course of real selling. The morning of the third day's session was taken up with a Victrola sales demonstration put on by David J. Arnold, manager of the Victrola wholesale division, assisted by F. W. Bonar, of the city sales department. This was followed by a talk on "The Victrola in the Schools," by Mrs. Robert A. Douglas, formerly of the educational department of the Victor Talking Machine Co., Camden, N. J. "More Sales Per Day," by H. J. Prada, manager of the mail order department, closed the morning's session.

Best in Store's History

According to Oscar Frazier, manager of the phonograph department of the Darrow Music Co., the month of December will go down as the biggest in the history of the company. Brunswicks and Columbias were sold and with them a phenomenal quantity of records. Mr. Frazier himself sold a \$250 machine after midnight, December 23. The record, "Three o'Clock in the Morning," was completely sold out with none on hand on December 30, one hundred and fifty of this number being sold on Saturday, December 23, with "Homesick" almost as strongly in demand. Records were big favorites as gifts.

Heavy Demand for Machines

The demands for Victrolas, Sonoras and Brunswicks were so heavy the week before Christmas that the phonograph department of the Denver Music Co. looked exceedingly bare on Saturday night, December 23. The beautiful corridor where machine after machine is lined up was stripped, with only two machines standing on the floor the Saturday before Christmas. "It was a wonderful month," said Manager H. W. Sanders, "and our record business was the best ever. The Denver Co. has been so long

RECORDING FOR THE TRADE

We have a modern well-equipped laboratory with facilities for producing the highest grade recordings. We Solicit Your Business

Manhattan Recording Laboratories
48 West 39th St. New York

Phonograph Toys

Sell the Year Round!



THE MAGNETIC DANCERS

This little couple will waltz, fox-trot or two-step in a most realistic manner. They reverse, turn and glide just as a couple would do on a ball-room floor. Price \$1.00.

There's the Rastus Family

Don't miss these favorites! The assortment consists of
 Ragtime Rastus \$1.25 Shimandy \$1.65
 Boxing Darkies 1.50 Fighting Roosters 1.65
 Just as easy to sell the four as one.

Usual Discounts to the trade

NATIONAL COMPANY
108 Brookline Street, Cambridge, Mass., U. S. A.



Pre-holiday demand for these toys this year exceeded that of the last three years. And repeat business since Christmas justifies the statement that they are profit-producers and that they'll sell the year round.

established in business here that a remarkably large clientele responds when new records are offered." Mr. Sanders said a few sales of the York, the new Brunswick console, were lost because of having run short of this type of merchandise.

Lack of Merchandise

A lack of merchandise lost sales of the Edison, according to Norman D. Tharp, manager of the retail and wholesale departments of the Denver Dry Goods Co., local jobber of the Edison. "In the wholesale end alone we could have sold two hundred more of the new Edison consoles had we been able to get this merchandise," said Mr. Tharp. "Our dealers in many parts of Colorado and other States in our territory were clamoring for these models, but we could not supply the demand. December was a big month with us and we worked until Sunday morning getting machines delivered, and not only Edisons, but Edison Re-creations sold out on several popular numbers."

Thirty-five Per Cent Increase

With the phonograph department of the Baldwin Piano Co. breaking all records for the month of December, J. H. Blinn, manager, reported a 35 per cent increase in business for the entire year over last year. Another point which came as a surprise was the business done in Sonora and Columbia machines since Christmas. "This was new business, not just hold-overs from before Christmas, but absolutely new business," said Mr. Blinn.

People Are Spending

"Money is loosening up and people are spending," said Manager H. V. Huntoon, of the Victrola department of the Knight-Campbell Music Co. "We had a big December and have had a good run of business since Christmas. You would be surprised to know how many different persons purchased sets of Walter Camp's Daily Dozen exercises set to music. Men buy them for their wives and wives buy them for their husbands. A lot of these sets were sold for Christmas gifts. The small portable phonographs are also in demand as well as many other styles."

Want Musical Instruments

"We find that people want musical instruments in their homes and once they have them they use a great deal of their Christmas money in buying records and player rolls for them," said Clarence G. Campbell, president of the Knight-Campbell Music Co. Several new features in the music line have been introduced

this season. For instance, there are new Q R S educator sets for player rolls, which are the newest invention for instructing beginners in music. They promise to be big sellers.

Stunt Gained Publicity

A stunt which gained wide publicity for the Charles E. Wells Music Co. was pulled off Saturday, December 23, when a truck with seventeen members of the City Band dressed as Santa Claus played sweet music while riding through the streets of Denver. From the truck copies of the latest popular sheet music were distributed free, several thousand copies being scattered as the truck passed on downtown Denver streets. Manager J. H. Baskerville says business in his small goods department went 50 per cent ahead of last year and on Saturday, December 23, \$1,000 was taken in on items in the small goods department. Terms on musical instruments handled in his department are higher than in other departments, the down payment being more, as well as the monthly payment.

Manager Thompson, of the Victrola department, expressed much pleasure over the volume of business done during December.



Artistic Decorating On Phonographs

Dealers and manufacturers, send your phonographs to us for decorations and special finishes. We maintain a high-class studio devoted entirely to this work. We will decorate your phonographs from our large selection of designs or from designs you may particularly specify.

Let us show you our work and submit estimate

MOHAWK WORKS OF ART
Mohawk Building
160 Fifth Avenue New York



The Number Seven Fixture constantly suggests a choice of Columbia Records to the customer in the hearing room. Unaided it has sold thousands of records—and helped alert salesmen sell thousands more. \$1.50 each—they pay for themselves the first hour they're up. At your Columbia Branch.

Columbia Graphophone Co.
NEW YORK

NEW ORLEANS

Holiday Sales Exceeded Expectations—Intensive Advertising Partly Responsible—Sales Clean-up Continues—Month's News

NEW ORLEANS, LA., January 8.—“Phenomenal,” was the way one sales manager described holiday trade. “Biggest in the history of the store,” said another, and it was one of the city's oldest music stores at that. Bonuses and commissions of clerks ran up to war-time heights. They ate two meals a day and a sandwich or two between sales at noon. The public swooped down in droves on the music stores, taxing the strength and endurance of the salesmen to the limit. “And I feel sorry for poor old Santa Claus if he has to deliver all the machines we sold,” said one pretty, tired salesgirl as she chalked up her last commission for the day, bringing the total up to \$350 for the month, including her salary.

Big Ad Drives Boom Sales

During the entire Christmas season the papers were filled with full-page advertisements featuring all lines. More money was spent on advertisements this year than in any previous year in the history of the trade, is the opinion of one of the old timers. Canal street department stores devoted an unusually large space in their Canal street windows to talking machine displays, but the space and money spent was returned tenfold and more than made up for the late start this year. It really seemed that talking machines ranked among the most popular gifts of the season.

Impartial Buying

J. D. Moore, manager of the music department of Maison Blanche, reported the largest business done in the history of the department. Cash sales improved. The buying was not partial to any one particular style or price. The people seemed to have money and they spent freely. “Our record sale was phenomenal. We carried an unusually large stock of records and were able to supply many of the numbers that the other stores were out of,” said Mr. Moore.

All Busy at Werlein's

Sam Rosenbaum, at Werlein's, scarcely had time to say Happy New Year. Every official and even some of the directors were behind the counter selling Red Seals and jazz records. Despite the unusually large stocks at the beginning of the season it was necessary for Werlein to borrow stocks from other Victor dealers. And so the story was repeated on down the line. At Edison headquarters W. W. Twigg reported records broken for December business. The limited stock was all that kept the figures from going higher. Orders from country deal-

ers were silent spokesmen of the big business going on in the country. Sugar planters and cotton men, who have been enjoying good prices for their products and who, heretofore, have been tight on expenditures till the crop was harvested and the bills of the past months paid, opened up and brought music into their homes for Christmas.

Medium-priced Edisons Lead

The medium-priced console models seemed to have been the best sellers in the Edison line, but the upright and record sales were not far behind. Dealers who have come to town from points in Louisiana and Mississippi report this the biggest December they have had in years and, further, that business has not slackened since that time.

And Still They Come

Ralph Young, head of the Victrola department of the Grunewald Music Store, said: “We surpassed by far last year's figure and we are not able to rest yet.” And it was true. In every booth on both sides of the aisle there were people buying records and in spite of the recently remodeled department, which is considered one of the best in the city for handling crowds, there were people standing in the aisle waiting to get into the booths.

Record Business, Says J. A. Hofheinz

Jolin A. Hofheinz, manager of the Southern Victor Jobbers at Werlein, Ltd., who has probably a better insight into what was really done than the retail men, says that this past month was not only the best month of the year, but was also far ahead of last December. “Christmas buying,” said Mr. Hofheinz, “was better than was anticipated. Many of the local dealers ordered extra large stocks, which they believed ample to take care of their requirements, but found later that they were short. Cash sales were surprising and the total was much larger than during the months previous.

“Probably the biggest feature about the Victor business was the volume of records sold. The movement of the Christmas releases was spectacular and the Red Seal numbers as well as popular dance pieces were greatly in demand. It was a common thing to sell \$25 to \$50 worth of records with a machine.”

Recent Visitors

Among the prominent visitors here recently was Rayburn Smith, president of the Unit Construction Co., Philadelphia, manufacturer of talking machine booths, record racks, etc. The Unit Co. has installed booths in a num-

ber of the local stores and will probably place others this year.

Mrs. Frances E. Clark was also a visitor. Mrs. Clark is known as the organizer of the educational department of the Victor Co. While here she spoke to the local dealers at Werlein's and also to the Parents-Teachers' Association and to the Normal teachers and pupils.

Employees at Werlein's were deeply shocked at the death of the son of Walter Schroder, manager of the shipping department of Werlein's. Only a few months ago they all joined in congratulating him on becoming the father of a bouncing baby boy. The mother and son were in Greenville, Ala., when the child was taken suddenly ill and died before the father arrived.

DE FOREST RADIO SETS EXHIBITED

Receiving Sets and Radio Parts Displayed at American Radio Exposition in New York

Among the exhibitors at the American Radio Exposition, which was held in the Grand Central Palace, New York, from December 21 to 30, inclusive, was the De Forest Radio Telephone & Telegraph Co., Jersey City, N. J. The De Forest Co. is one of the largest manufacturers of radio receiving sets and radio parts in the country. It has given particular attention to the sale of its products through the talking machine dealer, having appointed a number of music houses as distributors of its products. Among those in the talking machine industry who have been appointed distributors for De Forest goods are the Schmelzer Co., Kansas City, Mo.; M. Steinert & Sons, Boston, Mass., and the Rochester Phonograph Co., of Rochester, N. Y.

FINE SALES OF HOMOKORD RECORDS

Favorite Mfg. Co., New York, Distributor of Parts and Accessories. Reports Many Inquiries From All Parts of Country

Carl Kronenberger, head of the Favorite Mfg. Co., 105 East Twelfth street, New York City, manufacturer and distributor of talking machine repair parts and accessories, recently stated that since taking over the distribution of Homokord records through his company's purchase of the stock of the Hegeman-Stewart Corp., former distributor of these records, the firm has received inquiries from all parts of the country. The original announcement of the above purchase, which was made in the December issue of The Talking Machine World, resulted in a telegraphic order for 5,000 Homokord records from a dealer in Milwaukee, Wis. This is but an example of the splendid orders being received by the company.

The G. R. Lewis Drug Co., Cripple Creek, Colo., handling drugs and talking machines, has retired from business.

PHONOMOTOR PRODUCTS, PHONOSTOPS and NEEDLE CLIPPERS
ALWAYS THE BEST

PHONOMOTOR COMPANY

121 WEST AVENUE, ROCHESTER, N. Y.



The
**FLETCHER UNIVERSAL
TONE ARM and REPRODUCER**

Gives Proper Playing Weights for All Records. No Adjustment Screws or Springs
SAMPLES \$8.00 Specify 8½" or 9½" arm

FLETCHER-WICKES CO., 6 East Lake Street, Chicago, Illinois

THE McLAGAN PHONOGRAPH CORPORATION, LIMITED, STRATFORD, ONTARIO, EXCLUSIVE CANADIAN AGENTS

FLETCHER REPRODUCER

Scientifically

Constructed



Gives Perfect
Reproduction
of Voice
or Instrument

Volume and
Perfect Detail

Dealers, Send for
Prices and Terms

Reproducer
and Connection
for

NEW EDISON

Plays all Records

ACTUAL SIZE

Carried in Stock for Victor and Columbia

THE FLETCHER "STRAIGHT"

Design Patented November 29th, 1921



**STRAIGHT INSIDE—Taper Outside
BALL BEARINGS THROUGHOUT
NEW DESIGN NEW CONSTRUCTION**

It is universal and equipped with the Regular Fletcher Reproducer, giving the same natural tone quality as heretofore
Made in two lengths, 8½" and 9½" SEND FOR PRICES AND TERMS

FLETCHER-WICKES COMPANY
6 EAST LAKE ST. CHICAGO

THE McLAGAN PHONOGRAPH CORPORATION, LIMITED, STRATFORD, ONTARIO, EXCLUSIVE CANADIAN AGENTS

CLEVELAND

Optimism for Future Prevalent—Association Plans—Meier & Sons Celebrate—Dealers Tie Up With Theatres—Month's News

CLEVELAND, O., January 4.—While 1922 closes as one of the biggest years in the history of the talking machine industry in this territory, and probably the biggest, when final figures are compiled, still greater promise for 1923 is held in the opinion of both wholesale and dealer factions as the new year gets under way.

The outstanding feature with the turn of the year is the large amount of business that went begging with retailers for lack of certain kinds of instruments, and records also, with perhaps the greatest scarcity in console models of the standard makes, and the fact, from the viewpoint of wholesalers, that much of the unfilled business will carry over into 1923. In fact, the last week of December, usually looked upon as one of the quiet periods of the year, was the best, for this particular time, in the history of the local trade, many dealers asking that their original orders be allowed to stand.

All-embracing Association Interests

Still greater promise for added outlets for talking machines and records, along with other musical merchandise, is offered, however, in the plans of members of the Northern Ohio Talking Machine Dealers' Association to amalgamate with the Cleveland Music Trade Association, making for one large body that will shape plans toward stimulating still broader interest in music. With this joining of forces by two of the bigger factions in musical merchandising may come the addition of band instrument, sheet music and all the other elements identified with the music industry in a retail way.

The proposal for this amalgamation found its inception at the December meeting of the Cleveland Music Trade Association, at which time George R. Madson, president, the Cheney

Phonograph Sales Co., and William Gordon Bowie, the B. Dreher's Sons Co., were appointed to arrange a meeting for the reorganization of the Talking Machine Association. This meeting, according to Mr. Bowie, is planned for some time in January, at which time it is expected that a move will be started to bring into the Association dealers in all makes of talking machines. In the last few years the Association has had as members mostly those identified with the retailing of one line of instruments.

Ultimately it is planned, in the combined Associations, to have as a president a dealer in both pianos and talking machines, and as vice-presidents a piano merchant, who will head the piano division, as now represented by the Cleveland Music Trade Association, and a talking machine dealer who will act as chairman of the talking machine division.

Both joint and separate meetings may be held in order that the combined interests of the industries may be discussed on the one hand, or for the purpose of discussing problems peculiar to either branch of the trade.

As the organization is perfected plans will be developed for a program of publicity, designed to create added interest in music, with perhaps a Music Week, ending with a concert in the Public Auditorium, and other features, all backed by the trade organization, yet promoted in such a way that any motive looking to added business may be considered secondary.

Why 1923 Prospects Look Good

As to the natural outlet for new business during 1923, all leading jobbing interests agree that the best year is ahead. A better class of merchandise, and particularly standard instruments, are most likely to make up the bulk of

new business, while efforts of dealers to interest the public in the better music will have a sustaining influence on the talking machine itself. This last already has been proved by the depletion of stocks of records in more than one wholesale establishment here. The addition of many new dealers during the latter part of 1922 also will have an influence on the business for the new year. Finally, the large amount of unfilled orders in practically every wholesale house gives 1923 a better start than any year has had recently. These views are concurred in by such leaders as J. L. Du Breuil, district manager for Brunswick; S. S. Larmon, branch manager for Columbia; T. W. Wade, district manager for Vocalion; Howard J. Shartle, Cleveland Talking Machine Co., and Edward B. Lyons, Eclipse Musical Co., distributor for Victor; George R. Madson, president, the Cheney Phonograph Sales Co.; E. S. Hirschberger, advertising manager, the Phonograph Co., Edison wholesaler, and others.

Meier & Sons Great Celebration

The work of dealers in developing new business as an immediate factor, as well as for the future, has been commendable. That accomplishment of the L. Meier & Sons Co. stands out as one of the sensations of the 1922 holiday season, though the holiday business of this firm was done, in the opinion of Louis Meier, head of the firm, at least one full month ahead of time. This was the result of the twenty-fifth anniversary celebration, which ended a twenty-five-day session during December, and resulted in attracting the direct attention of close to a quarter of a million persons.

The Meier firm started business a block from the present main store location in a tiny shop that was a one-man proposition. To-day the main store of the company is one of the show places of Cleveland. There are two other stores, both large and attractive. The firm now comprises Mr. Meier himself and his sons, Leonard and Louis, and his daughter, Lillian, and one of the largest staffs maintained by a retail talking machine establishment in these parts. From the beginning the firm has handled exclusively the Victor line. Mr. Meier is the present president of the local Talking Machine Dealers' Association and held that post once before—a tribute to his standing.

Another Successor to Caruso

Local talking machine dealers who have found the Caruso records a profitable investment are somewhat interested in the statements being made by certain Cleveland music critics that they believe they have found the successor to the late tenor, and right here in town. The subject of the discussion is one Frank Siskano, at present a shoemaker who is getting along fairly well at his trade, but who is claimed to be due for concert honors. Anyway, the critics that have him in hand claim to be putting his voice in shape and promise to let Cleveland hear their find before the present season is over.

Helping the Dealers to Sell

Commendable work has been done by wholesale factors for the benefit of retailers in local "tie-ups" during the last few weeks. Introduction of the Tudor model of the Brunswick was made simultaneously with the appearance of Marion Davies at the Stillman in "When Knighthood Was in Flower," her film name for the moment being Mary Tudor. The new Brunswick model was seen in the lobby and pictures of the scenes in the film were displayed by Brunswick dealers, so that it was a fifty-fifty proposition for theatre and dealer. Details were arranged by Ernie F. Hughes, service director for Brunswick in this district.

Two other interesting features along the same line were arranged by the Columbia Graphophone Co.'s Cleveland branch staff, Miss Millicent Mower using a Columbia instrument at the Keith Palace in a duo-act, while a Columbia instrument and records by her were shown at the State when Nora Bayes appeared at that theatre.

The next big link-up for Columbia interests

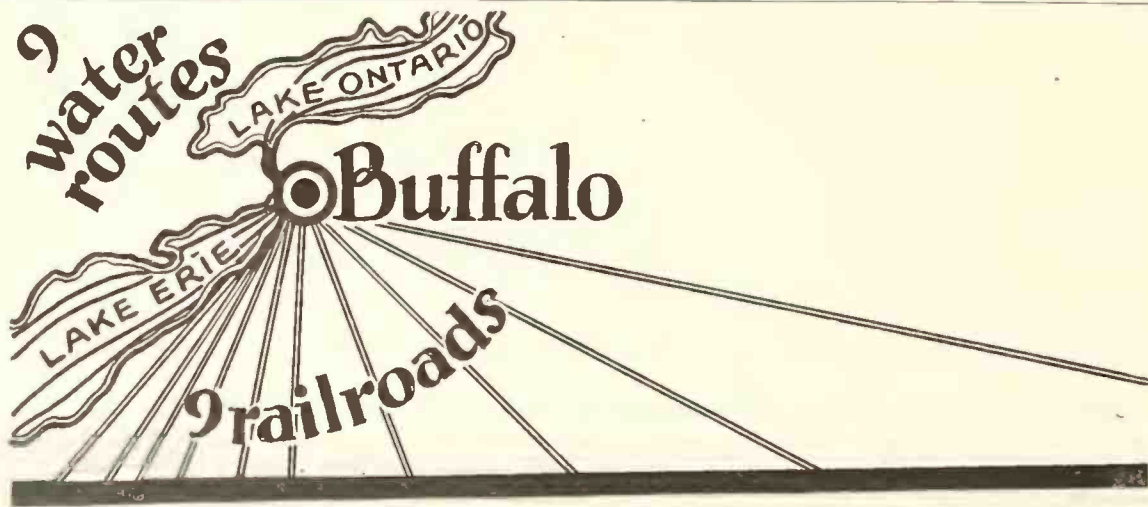

BUFFALO *A NIGHT'S RIDE FROM EVERY IMPORTANT TRADE CENTER IN THE EAST*

The veritable network of shipping facilities which Buffalo offers to Victor dealers—is the answer why the Buffalo Talking Machine Co. service is reaching a larger number of dealers each year.

This is unquestionably a real service which builds long-lasting friendship with a better and more efficient business for all.

Why not try this service? It will pay you.

BUFFALO TALKING MACHINE CO.

Victor Wholesalers
BUFFALO, N. Y.

may be the personal appearance of Paul Specht and his orchestra for a fraternal organization dance at the Public Auditorium. If negotiations are carried through, what is said to be the highest price ever paid in Cleveland for a single appearance of an orchestra will be paid to this Columbia artist.

Change in Brunswick Managers

The turn of the year brings a change at the local Brunswick headquarters, J. L. Du Breuil, district manager, resigning to go into other business, and Leslie I. King, formerly with the Morehouse-Martens Co., Columbus, coming here in that capacity. Mr. Du Breuil is credited with putting Brunswick decidedly on the map in this territory, not only bringing it to the front in the immediate Cleveland district, but in the Buffalo and Pittsburgh sections, which are embraced in the territory as well.

New dealers established by the Columbia Co. in the last week or so include the Hall Music Co., at Warren, and the Fred Norton establishment at Findlay, both live-wire merchants.

**ROBICHEK
ART DECORATIONS
Are Recognized by Leading Experts
as works of
GENUINE ARTISTRY**



SPECIALISTS IN
Japanese and Chinese Lacquer—Antique Reproductions—Period Designs in any Finish—Polychrome—Expert Gilding.

We invite you to come and inspect our work. Write or telephone for appointment.

Rudolph Robichek
Works of Art
120 Lexington Ave.
Telephone Mad. Sq. 7035

Among the social events that ushered in the new year was the party for Brunswick employees held at the warerooms, about fifty attending, with dancing, refreshments and specialties arranged by E. F. Hughes, service manager, and Miss Gwen Tremble, assistant.

REPORTS ON TRAFFIC CONDITIONS

Raymond L. French, Traffic Manager of Columbia Co., Delivers Report on Traffic Conditions Before Manufacturers

NEW HAVEN, CONN., January 6.—A vote to aid the fight to make the open shop "prevalent" in all industries, refutation of the usefulness of any "third party" in the settling of disputes between labor and industrial leaders and denial that any contribution has been made to political science since 1787, were part of the busy day undertaken by a gathering of the Connecticut Manufacturers' Association in triple session in annual meeting in the Hotel Taft in this city recently.

Raymond L. French, chairman of the traffic committee and traffic manager of the Columbia Graphophone Co., of Bridgeport, presented the report, which is in part as follows:

"Due to war conditions, Government control, labor unrest and other conditions over which they had no control, the carriers have not kept up with the growth of commerce and this has set us back to the condition which prevailed a few years ago, that is a retarding of business due to embargoes, car shortages and locomotive failures. I believe, however, that generally speaking the carriers have done all that could be expected under the circumstances and that a vote of thanks should really be given to them.

"There has been no time in the history of railroading when the spirit of co-operation between carriers and shippers was more paramount than at present.

"Motor transportation, in one phase or another, is a subject which we have with us always.

"The railroads state, and with considerable truth, that the truck is taking the cream of the short haul business from them, leaving only the skim; that our country cannot continue to prosper without railroad transportation and for that reason we who use trucks should go slow, as we are depriving them of millions of dollars yearly which are greatly needed in rehabilitating their systems in order that they may handle our necessary long-haul business.

"Your committee feels that there is a proper sphere in the transportation field for both the railroad and the truck, but that so far very little effort has been made to locate the economical position which these two methods of transportation should hold and until this has been done no definite recommendation can be made as to economical aspects of the situation.

"We, therefore, feel that this Association should, in conjunction with other Associations of New England, and possibly the railroads, employ a commission consisting of suitable members who shall make it their business to study this proposition thoroughly, reporting back as to what action should be taken, from a New England standpoint.

"This would entail a very considerable expenditure of money and for that reason we feel no one organization should attempt to handle it alone. In union there is strength."

W. B. SPRATT OPENS NEW STORE

TOLEDO, O., January 6.—W. B. Spratt, who has been operating a music store in Fostoria, O., for the last two years, has opened a music store at 440 Superior street, this city. He will carry a standard line of talking machines and other musical instruments as well as a complete line of sheet music.

The Pardee Phonograph Corp., of New York City, has reduced its capital from \$1,250,000 to \$200,000.

**REGAL
50c
RECORDS**

have become famous for consistently giving full 75c of record value for 50c!

They are known and bought nationally because of this value!

And to the dealer they offer profit insurance. They increase his turnover—multiply his profits!

They bring him a bigger and better business throughout the year!

REGAL RECORD CO.
20 W. 20th ST. NEW YORK



"Home, Sweet Home" and Rosa Ponselle—can you imagine a happier inspiration? The glorious golden voice of this great operatic artiste melting into the beautiful melodies of this simple old ballad is ecstatic. 49935 on the February list.

**Columbia Graphophone Co.
NEW YORK**

FINE EXHIBIT AT RADIO SHOW

Henry Hyman & Co., Inc., Display at New York Radio Show Attracted Widespread Attention—Travelers Called in to Meet Dealers—Many Prospects Secured Through Exhibition

Henry Hyman & Co., Inc., manufacturers of "Bestone" radio receiving sets, New York, were represented at the radio show recently held at the Grand Central Palace, New York, with one of the most effective booths in the show. Every model of radio receiving set which the company manufactures was displayed there, and during the show a large number of people were entertained by sales representatives who were in attendance and, in consequence, many substantial orders were booked. The show produced real tangible results, as not only was a keen interest aroused among the public generally, but a large number of radio dealers showed a buying interest with the result that "Bestone" sets were given wide publicity, says Wm. A. Bresalier, advertising manager of the company.

The company called in their sales representatives from the road to enable them to attend the show and meet dealers from their respective territories. Among the representatives were V. V. Schaefer, E. L. Anglin and B. Muldoon. S. Colbert, sales manager of the company, in conjunction with Mr. Bresalier, supervised the Hyman activities of the show and were in attendance during the entire time. Everything considered, according to officials of the company, the show from their standpoint was a complete success, and in addition to actual sales made many promising prospects were secured that will mean business later on.

VARNOL

"Clears the Way to Good Music"
(Copyrighted)

¶ A perfected and tested cleaning fluid that brings new life to old records by cleaning away the dirt and dust and bringing back the original music.

¶ For use on new records as a means of clearing off the wax coating that forms part of the packing protection.

**1 oz. bottle capable of
cleaning 150 double-
faced records, \$1.50**

REGULAR TRADE DISCOUNTS

The Varnol Co.
Room 3002, Woolworth Bldg., New York

FIRST ONEGIN RECORDS RELEASED

First Recordings by Mme. Siegrid Onegin, Metropolitan Artist, Announced by Brunswick Co.—Eagerly Awaited by Dealers

The Brunswick-Balke-Collender Co. is announcing this month the first records to be released of Siegrid Onegin, operatic and concert artist, who recently made her debut in New York City. This artist is well known in European musical circles where she has made an enviable reputation. The first American ap-



Siegrid Onegin

pearance of this famous singer with the Metropolitan Opera Company was loudly heralded by New York critics as the revelation of a new figure in the operatic world. Mme. Onegin's favorite operatic roles are Carmen, Delila, Amneris and various Wagnerian parts. Her repertoire also includes many French and Italian folk songs as well as many of the songs by the modern composers.

Her first records have eagerly been awaited by Brunswick record enthusiasts throughout the country, and it is expected they will be received everywhere with great interest. Wm. A. Brophy, general manager of the Brunswick recording laboratories, who supervised the making of these records, is keenly enthusiastic about the possibilities of this new singer and stated that her magnificent voice is so perfect and her interpretations so flawless that Mme. Onegin has the ideal recording voice.

ORANOLA DISPLAY AT RADIO SHOW

The National Radio Products Corp., 509 Fifth avenue, New York City, which has been appointed agent for the Oranola receiving sets, manufactured by the Oranola Radio Corp., demonstrated this product at the recent radio show in the Grand Central Palace, New York City, which was held under the auspices of the American Radio Exposition. The Oranola is a combination talking machine and radio receiving set, manufactured in upright and console types.

GIVES DEALERS USEFUL GIFT

Knickerbocker Talking Machine Co. Presents Its Dealers With a Novelty Ash Tray

The Knickerbocker Talking Machine Co., Victor wholesaler, New York City, presented its many dealers with a novelty at Christmas-time that was both attractive and useful. This novelty consisted of a copper ash receiver of the type known as Ever-Kleen. Two cigar or cigarette rests are provided and upon the slight raising of the ash trap the ashes are dumped into a covered receptacle beneath. Judging from the many letters received by Abram Davega, president of the company, this novelty has made a big hit.

BIG DEMAND FOR NEW TONE ARMS

Improved Tone Arm of Mutual Phono Parts Mfg. Corp. Growing in Popularity

The Mutual Phono Parts Mfg. Corp., New York City, has announced an improvement on its portable tone arms. On the new arms the swivel pin will be insulated with fibre, and three sizes of arms will also be made, 6½ inches, 7½ inches and 8½ inches, respectively. Orders on hand for these new tone arms now number several thousand. Accordingly, A. Frangipane, secretary of the company, reports that the outlook for 1923 seems very good and in anticipation of increased business the company is enlarging its offices and making plans for improved delivery service.

A hot temper has been the downfall of many a good man. In business it is especially important that a man keep control of himself.

VICTOR DISTRIBUTORS

PERRY B. WHITSIT CO.

Record Business

THE Whitsit organization is paying close attention to the dealers' activities in connection with the development of Victor record business. Our facilities and experience are at your disposal—why not take advantage of it?

COLUMBUS-OHIO

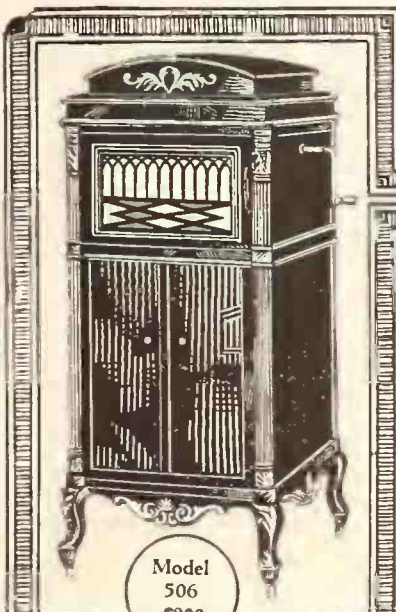

Model 506 \$200

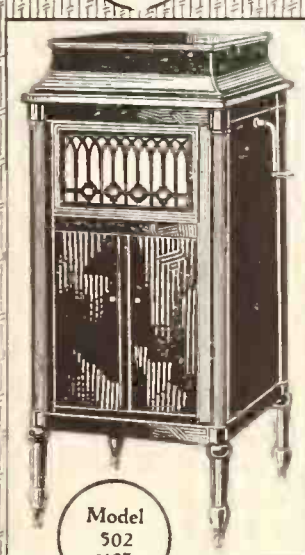

Model 502 \$125

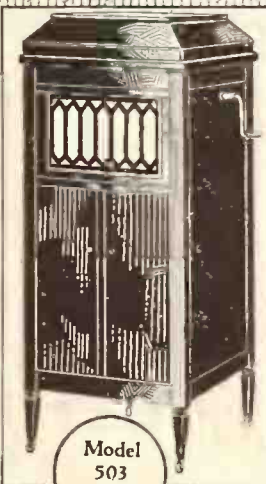

Model 503 \$135

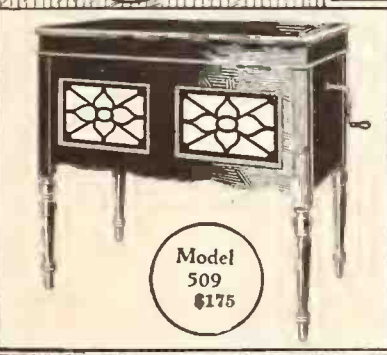

Model 509 \$175

STEGER

the finest reproducing Phonograph in the World

PICTURE to yourself the ideal phonograph — so truly marvelous in its wonderful tone-reproducing qualities, that it creates to perfection the illusion of reality.

You will then appreciate the supreme achievement of skilled craftsmanship in the production of the superb Steger.

When you listen to the Steger Phonograph, you seem to hear the actual tones of the piano or violin, band or orchestra — and the sweet notes of the human voice come to you, as if the singer were in the room. Clear, resonant, life-like is all music reproduced by the artistic Steger.

The exclusive Steger features, that make this fidelity to original tone-values possible, are valuable selling points. The remarkable Steger tone-reproducer, the tone-chamber of even-grained spruce and the easily adjustable tone-arm merit your consideration.

You can make the Steger an important asset of your business because of the quick turn-over and because each sale produces a second sale.

Write for the Steger proposition today! Desirable territory open.

Phonograph Division

STEGER & SONS

Piano Manufacturing Company

Established by John V. Steger, 1879

Steger Building, . . . CHICAGO, ILL.

Factories: Steger, Illinois, where the "Lincoln" and "Dixie" Highways meet.

"If it's a Steger—it's the most valuable Piano in the world."

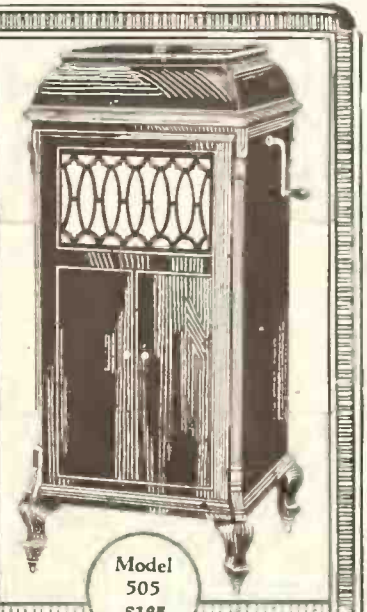

Model 505 \$185

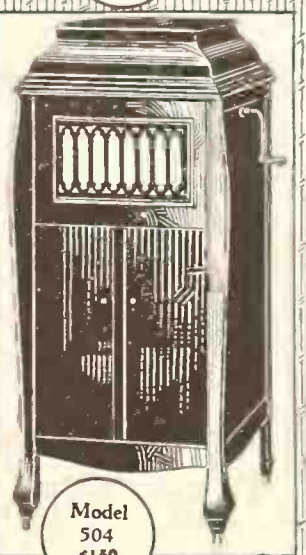

Model 504 \$160

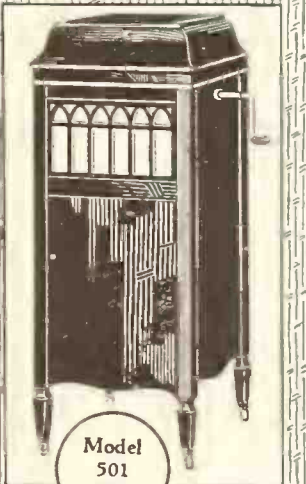

Model 501 \$100

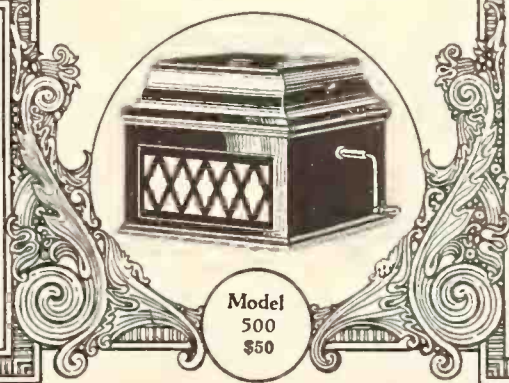

Model 500 \$50

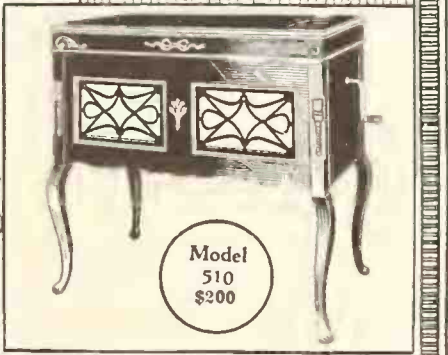

Model 510 \$200



Oh, La-dy Luck, wait you smile on me? 'I've wait-ed so long and pa-tient-ly,

LADY LUCK

A GEM SONG FROM THE NEW MUSICAL COMEDY

"UP SHE GOES" by the writers of "IRENE"

"You can't go wrong
With any FEIST song"

ARTISTIC BRISTOL CO. FOLDER

Colored Folder for Talking Machine Trade Describes Varied Products—Attractive Exhibit Made at the New York Radio Show

The Bristol Co., of Waterbury, Conn., manufacturer of Bristol's Audiophone phonograph record reproducer, the Audiophone and Audiophone junior, has produced a particularly attractive eight-page folder in colors for the talking machine trade. The many needs for the line are illustrated by both word and picture and the many fine points of the instruments are described in detail.

The Bristol Co. exhibited at the recent radio show in the Grand Central Palace, New York City, showing the Audiophone and Audiophone junior for radio reproduction as well as for the talking machine. A new development in the radio field was also shown, Bristol's one-stage power amplifier. The Bristol space was filled by large numbers of visitors throughout the entire course of the show.

A feature of the exhibit was the new Bristol portable talking machine. This new machine is entirely for use with the Audiophone reproducer and loud speaker as it consists of practically only the cabinet, motor and turn-table. The Bristol reproducer is especially designed for electrical transmission and is adapted separately to that or any other talking machine. Included within this portable machine is a control box for the loud speaker in the space usually occu-

ried by the sound chamber. The electric motor used in this portable is worthy of particular notice as it has been especially designed for the Bristol Co. It operates on a 32-volt current (farm lighting circuit) equally as well as it does on 110 alternating current or direct current, thus making it in every sense of the word a universal electric motor.

ATTRACTIVE REGAL PUBLICITY

Regal Record Co. Featuring Popular Numbers in Series of Window Strips

The sales department of the Regal Record Co., 18 West Twentieth street, New York City, recently issued a new series of window strips which have been received with favorable comment from the trade. Among the strips is a large streamer which has proved particularly effective. The entire set consists of five strips printed in two colors, some carrying humorous illustrations. Each strip carries the titles of two popular numbers. These are mailed each month, together with a complete auxiliary poster service, and are furnished gratis. The latest mailing of advertising material from the Regal Co. contained nineteen complete pieces of advertising poster work.

The Hecht Co., Washington, D. C., department store is featuring its line of talking machines in exceptionally artistic window displays which are attracting considerable attention.

OUTLINES EMERSON POLICIES

Arthur H. Cushman, Director of Sales, Issues Statement to Trade—Plan to Extend Dealer Service to Stimulate Sales

Arthur H. Cushman, director of sales of the Emerson Phonograph Co., Inc., has forwarded a statement to the trade in which the coming policies of that organization are outlined. It makes clear the fact that the Emerson Phonograph Co., Inc., has, with few exceptions, an entirely new organization and personnel and is manufacturing a new Emerson record.

The statement says that the new Emerson record will continue to be marketed at seventy-five cents retail and that the company does not intend to manufacture a lower-priced record. The statement closes extending thanks to its several thousand dealers for the hearty appreciation and the enthusiasm shown the new Emerson products.

The coming plans of the Emerson Co. call for an extension of its dealer service and these will include co-operation that will assist in creating sales. There will shortly be opened branch offices of the Emerson Phonograph Co. in Boston and Philadelphia. B. Abrams, president of the company, left early this month for the above two cities for the purpose of closing negotiations for the quarters in those localities.

The new branches will carry complete stocks of Emerson records and Emerson phonographs and a direct service to dealers in those particular territories has been arranged and will become immediately available.

GOING AFTER ITALIAN BUSINESS

Emerson Phonograph Co. Extending Activities in Italian Department—Many New Releases of Italian Recordings to Meet Demand

Paul Bolognese, director of the Italian department of the Emerson Phonograph Co., Inc., is greatly extending the activities of that department of the firm's record catalog. The Emerson Co. is releasing many new Italian-Neapolitan selections. These have been cataloged with great care and were included to meet the particular needs of the Emerson Co.'s Italian clientele.

Among the artists who are recording for the Emerson Phonograph Co., Inc., are Ria Rosa and Raffaele Balsamo. These distinguished Italian artists are particularly popular with Italian song lovers and engagements to record selections for the Emerson Phonograph Co., Inc., were made prior to their arrival in the United States.

Mr. Bolognese is a musical director of international note and brings to the Emerson organization some original plans for the extension of its foreign record catalog.

A branch store has been opened by the Topeka Music Co. at 633 Kansas avenue, Topeka, Kan. Edison phonographs are handled.

I Offer

VICTOR TALKING MACHINE CO. STOCK

at

\$164.00 per share
subject to change

*Return, based on 1922 dividends,
better than 6 per cent.*

FRED W. KNIGHT

Investments

Widener Building

PHILADELPHIA, PA.

The Trade in PHILADELPHIA and LOCALITY

PHILADELPHIA, PA., January 6.—The talking machine trade of the Quaker City has just closed one of the busiest holiday seasons and most successful years in its entire history and now instead of being able to enjoy a brief rest its members are engaged in the rush of stock-taking in order to start the new year with decks cleared for action and with every prospect for a record-breaking year ahead of them.

On every side, from distributors and dealers, both large and small, are heard emphatic expressions of satisfaction over the holiday business, and while few of the members of the trade report record-breaking Christmas sales they are united in agreeing that business during this period more than equaled expectations and, in fact, their stock resources.

The distributors of the Victor, Edison, Brunswick, Columbia, Cheney and other talking machines are congratulating themselves upon the manner in which they handled the tremendous quantity of orders received during the pre-Christmas rush. Their dealers admit having received the best and fairest treatment possible under the circumstances, which were such that the six weeks before Christmas were filled with an almost continuous clamor for the delivery of machines.

Harry W. Weymann Is Confident

The manner in which Harry W. Weymann, of H. A. Weymann & Sons, summed up the situation is almost identical in every respect with the expressions of the other large distributors of the city.

"We have just finished one of the most profitable and successful holiday seasons in our history and, judging from prevailing business con-

ditions and general outlook from every viewpoint, we are now expecting and planning for the biggest year since this business was founded," he said. "Moreover, we are not anticipating even a brief lull in business. This attitude is based partly on the fact that Victor advertisements published before Christmas, which have had great influence, urged prospective customers to make their purchases during the new year with the cash gifts that many undoubtedly would receive on Christmas."

Strong Rush at Brunswick Branch

O. F. Jester, manager of the Brunswick branch, certainly has passed through a very busy Christmas season with flying colors, as he was untiring in his efforts to secure required shipments of Brunswick machines for distribution to local dealers, with the result that he received shipments up until almost the day before Christmas. Although he was unable to obtain large quantities of machines during the last week of the rush, he distributed the machines just as fast as they were received from the factory.

Campaign for New Edison Dealers

Arthur Rhinow, of the Girard Phonograph Co., distributor of the New Edison phonograph, states that the holiday business was far in excess of that transacted last year. He announces that they are about to start a most thorough and comprehensive campaign for new dealers. According to present plans this drive will be the biggest ever attempted and will be carried out on a consistently large scale. Persuasive literature has been prepared for use in the campaign and the envelopes in which a series of letters and circulars will be mailed, are deco-

rated with a drawing that appeared some time ago in *The Music Trade Review*, featuring the encouraging slogan of "Dig 'em out, boy! The business is there if you go after it!"

"For some time past we have not made any great effort to secure new Edison dealers," said Mr. Rhinow, "but now that we are prepared we are planning a big campaign to get dealers. We believe that in our territory there are many virgin fields, rich in prospects, and it is with the view to reaching these prospects that we are starting our drive for new dealers in these areas."

Good Columbia Distribution

Officials of the local Columbia branch report that while their every resource was taxed to the limit in order to accomplish the feat they were able to satisfy the demands of their dealers in this territory and every possible precaution was taken to insure a fair and equitable distribution of the Columbia machines as rapidly as they were available.

Penn Co. Purchases Building

The Penn Phonograph Co., one of the big Victor distributors, has recently purchased the handsome four-story building at 913 Arch street, which it now occupies, thus insuring a permanent home for this up-to-date concern.

Edison Concerts Via Radio

Radio fans will now have the opportunity to hear the Edison Re-creations through the air via wireless, as Durham & Co., whose big station is at Nineteenth and Market streets, will frequently feature "Edison concerts," as they have just secured a handsome new Edison model through the courtesy of Everett Keefe,

(Continued on page 96)

What about 1923?

Good business is possible for every Victor Dealer if he will recognize the underlying essentials for creating and procuring it.

HARD WORK

properly applied is the surest method of getting business and every Dealer can put this into his business without creating any additional overhead.

THE LOUIS BUEHN COMPANY
OF PHILADELPHIA



WITH our record of Victor service in the past as a foundation, we aim during 1923 to not only maintain, but build to a still higher plane, Talking Machine Co. service to Victor retailers.

The Talking Machine Co.
Victor Wholesalers

1025 Arch Street Philadelphia, Pa.

"LET PHIL FILL 'EM"

THE TRADE IN PHILADELPHIA AND LOCALITY—(Continued from page 95)

the progressive head of the special Edison department at Snellenburg's department store.

Greeting From Everybody's T. M. Co.

Samuel Fingrudt, secretary of Everybody's Talking Machine Co., Inc., of this city, in a greeting addressed to the trade at the end of the year, stated that the company closed the most successful year in its history. In referring to future activities Mr. Fingrudt stated: "We are constantly building castles in the air, but we are also building some mighty strong foundations to hold these castles, with a well-known organization and a large number of friends throughout the trade."

Victor Dealers Enjoy Smoker

Nearly two hundred members of the Philadelphia Victor Dealers' Association and their guests made merry at the successful smoker held by that body on Thursday, December 28, on the Adelphia Roof Garden. During the evening addresses were made by George W. Hoover, president of the organization, and Louis Buehn, the well-known Victor distributor. Robert McCarthy, manager of Gimbel's phonograph department, was the chairman of the committee in charge of the event and the great success of the smoker was due in no small measure to his untiring efforts and the en-

thusiasm of his fellow committeemen, George Witney, manager of Heppe's, and H. Royer Smith, whose store is located at Tenth and Walnut streets.

The affair was enlivened by a vaudeville program consisting of ten numbers, which included such notable features as Billy Star, the New York fashion plate; Ann Peters, comedienne; Carson and Willard, comedy entertainers; the Whirlwind Dancers and many other acts. Music was furnished by a jazz band under the direction of Raymond Steen. Several amusing prizes were awarded various guests and a number of humorous telegrams were read from President Harding, Lloyd George, B. B. Todd, Jack Dempsey and other notables, who regretted their inability to attend the festivities.

Finds Conditions Stabilized

"Anyone may judge how successful our holiday trade was by the fact that we not only sold every available machine, but we could have disposed of many, many more if we could have obtained them," is the statement of G. Dunbar Shewell, president of the Cheney Phonograph Co. Mr. Shewell says he expects conservative and satisfactory business during the new year. He states that he is facing the prospects for 1923 with distinct optimism, as he feels that

credit conditions have now been stabilized and that confidence is again restored among not only the buying public, but the trade as well.

Hold Formal Opening

The Linton Co. recently opened its store at 24 South Fifty-second street, which it took over from Burton McCaulley. Large quantities of roses were a feature of the decorations at the formal opening, which was attended by large crowds, and the officials of the concern report that their holiday business far surpassed their expectations.

Wm. L. May Recovered From Illness

William L. May, of Heppe's sales force, who travels through Delaware, New Jersey and southern Pennsylvania, returned to his duties recently after a long illness.

New Manager for Ludwig Co. Department

C. L. Luedeke, formerly of Luedeke & Wagner, of West Philadelphia, has recently assumed his new duties as manager of the phonograph department of the Ludwig Piano Co. at 1103 Chestnut street. He is reorganizing the entire department and instituting many new plans to get a larger share of business.

Brunswick Sales Conference

O. F. Jester, manager of the Brunswick distributing branch, recently attended a sales conference held here to hear Edward Strauss, the sales manager of Brunswick's Eastern district. Several other officials were present and final plans were made at that time for the manner of handling the big Christmas trade efficiently.

Installs New Booths

Three additional phonograph booths have just been installed in the store of J. B. Gillies, at 2200 North Broad street. This improvement has been made necessary through the increasing patronage that is being attracted by the energetic business methods of Frank Cook, the manager of the store.

Reports Successful Holiday Season

O. Kern, manager of the United Music Stores, of this city and Baltimore, reports that the holiday season was satisfactory in every respect and that generally good business has continued over into the new year.

Enjoys Record Business Year

Everybody's Talking Machine Co., of this city, has concluded the biggest year in the history of the organization. During 1922 the business of the company grew to such proportions it was necessary to move to larger quarters, which it now occupies at 810 Arch

1923

FOR the New Year, we pledge our continued hearty cooperation that has distinguished Weymann Victor Service in the past.

H. A. WEYMAN & SON, INC.

VICTOR WHOLESALERS

1108 Chestnut Street

Philadelphia, Pa.

Authorized distributors of BUESCHER TRUE TONE Saxophones and Band Instruments

Manufacturers of WEYMAN "KEYSTONE STATE" String Instruments

Wholesale distributors of Q · R · S Player Rolls

Italian Music Rolls

Largest collection of Italian and other foreign music rolls in the United States. Catalogs and discounts on application.

UNITED MUSIC STORES

619 Cherry Street
225 W. Mulberry St.

Philadelphia, Pa.
Baltimore, Md.

Cable Address Reg'd
"Fillasse-Phila."

Send for Samples and Special Quantity Quotations

Long Distance Phone
Baring 0535

IMICO INDIA RUBY MICA DIAPHRAGMS

International Mica Co.

GENERAL OFFICES AND FACTORY: 37th and BRANDYWINE STS., WEST PHILADELPHIA, PA.

THE TRADE IN PHILADELPHIA AND LOCALITY—(Continued from page 96)

street, this city. The officials of the company all look forward to good business for 1923 and the extensive sales campaign planned for the coming year will, undoubtedly, result in even surpassing the admirable record of 1922.

Everybody's Talking Machine Co. specializes entirely in talking machine parts and through quality of product and service rendered has built for itself an enviable position.

C. W. FLOOD JOINS GENERAL RADIO

Made General Manager of Talking Machine Division of General Radio Corp.—Remarkable Growth of Sales in Past Year

PHILADELPHIA, PA., January 2.—Walter L. Eckhardt, president of the General Radio Corp., of this city, has announced that beginning with the new year the talking machine division of the organization has been under the supervision of C. W. Flood as general manager. Mr. Flood needs no introduction to the talking machine industry. His position for many years as manager of the Interstate Phonograph Co., Pathé distributor of this city, earned for him many sincere friends throughout the trade. It will be remembered that Mr. Eckhardt was formerly president of the Interstate Phonograph Co. and thus Mr. Flood and Mr. Eckhardt are reunited in co-operative work after a comparatively short period apart. Since Mr. Eckhardt formed the General Radio Corp. he has had associated with him many of his former co-workers, such as C. S. Tay, H. A. Pope and now C. W. Flood.

Both the talking machine and radio divisions of the company have shown remarkable growth during the past year. The talking machine department has charge of the distribution of Strand phonographs and Okeh records. Mr. Eckhardt reports that record sales have passed all expectations and phonographs are going strong.

Radio business has also been exceptional both on R C A sets, of which it is distributor, and the Geraco line of parts, which it manufactures. The Music Master horn has also enjoyed exceptional success.

Christmas day did not see the end of this good business as each morning thereafter the mail was filled with substantial orders and many complimentary expressions from dealers on the quick salability of the products. Mr. Eckhardt stated: "As we enter the new year I feel confident that it is going to be an exceptionally satisfactory one."

J. Henry Ling, founder of the Ling Piano House, 1266 Library avenue, Detroit, Mich., has decided to remain in business instead of retiring, as was announced a year ago.

J. A. CRABTREE VISITING EUROPE

Vice-president of the International Mica Co., Philadelphia, Analyzing Conditions Abroad

PHILADELPHIA, PA., January 2.—James A. Crabtree, vice-president of the International Mica Co., of this city, sailed last month on the "Olympic" for an extended visit to Europe. This is



James A. Crabtree

one of a number of trips that Mr. Crabtree has made to the other side, all of which were undertaken as a means of providing maximum service to users of Imico products. As on other trips, Mr. Crabtree will thoroughly investigate and analyze conditions in the various market centers of Europe for a comparison of products and notation of improvements.

During the past year the International Mica Co. secured as a subsidiary the Pennsylvania Radio Laboratories, manufacturer of a wide line of radio apparatus for dealers and distributors. The line is wide in scope, including a cabinet model known as No. 1001, which is attractively encased in a solid mahogany cabinet made by the Unit Construction Co., also of this city. The cabinet is exceptionally well finished and equipped with heavily nicked hardware and polished black molded parts. The company also manufactures a popular unit line enabling the purchaser to start with three units and add one unit at a time until the number five combination is reached. The company guarantees this set a radius of 1,000 miles. In addition to the complete sets a line of accessories is manufactured to take care of the requirements of the amateur who wants to build his own set. Model 1001 is reported to be finding particular favor in the talking machine trade. It is said that this set has been simplified to the point where there are only two major adjustments and the acoustic principles have been perfected to a remarkable degree. It is also stated that this model is being merchandised on an exclusive territory proposition without any large order guarantees. The catalog No. T-177 is now ready for distribution and is said to constitute an important handbook in the radio field.

PURCHASES ANSONIA MUSIC SHOP

Cornelius Abelowitz has purchased the stock and retail warerooms of the Ansonia Music Shop, Inc., 2130 Broadway, New York City. The store will carry Victor and Brunswick talking machines. Mr. Abelowitz was formerly a member of the Abelowitz Phonograph Co., 1353 St. Nicholas avenue, New York City, and is the brother of Chester Abelowitz, of the Eastern sales department of the Brunswick-Balke-Clender Co.

DECALCOMANIA

Name Plates for Talking
Machines, Pianos, etc.

High Class Workmanship

Write us for further information

National Decalcomania Co.
220-230 N. 60th St., Philadelphia, Pa.

On Guard



Penn-Victor Dogs are the best watchmen of Victor
Welfare in the Home.

Sold by most Victor Distributors.
Write them or us for prices.

Penn Phonograph Company

913 Arch Street Philadelphia, Pa.

Victor Wholesale Only

New Conceptions of Business Practice Are Assuming Growing Importance :: By W. Braid White

It is not far from the truth to say that the popular thought has changed more upon matters usually considered to be fundamental during the years since 1914 than during the previous quarter-century at least. In some ways we seem to have come forward a century during these last eight years. For all this the war is responsible not half so much as are the conditions of which the war was the climax. The world in, say, July, 1914, was a volcano of passions, emotions and beliefs which had been simmering for more than a century and which in any case would sooner or later have boiled over. The war came, and the whole cauldron shot out the devil's brew

which for so long had been cooking in it. The release of the pent-up energy has, of course, been accompanied by the usual excesses and exaggerations. But one result is definite enough: thought has been freed to an extent wholly unforeseeable. In every department of human action there has been, since 1914, a freedom of discussion and a boldness in drawing conclusions which before that year would have been wholly impossible.

Fundamental Business Thinking

Business has not escaped the impact. Business men are thinking to-day about the fundamentals of their position as they have never thought before. They are questioning axioms

which have for long been considered unquestionable and principles which were thought to have been demonstrated beyond cavil. There is much dissatisfaction among all who are not content with mere drifting, but this is to the good. It is highly desirable that there should be plenty of discussion on all fundamentals. The more there is the healthier will be our state of mind and the more likely we shall be to attain correct thinking and, consequently, true remedies for any evils or defects we may discover. The greatest mistake in the world is the mistake of stifling free inquiry and gagging free speech. A democracy certainly has no right to frown on free discussion, for what is democracy but government by discussion? When business men feel that anything about business ought to be regarded as too sacred for inquiry, except the principles of truth and honesty, then we may be sure that there is something wrong with the conduct of these business men and with their ideas about business.

Right and Wrong Ideas of Salesmanship

The motive power of business is salesmanship, which, we regret to say, had become popularly classed with something not far from trickery. That is to say, the salesman had come to be regarded as a person who kept business moving by means of his personal magnetism, his good fellowship, or something else only remotely connected with the merits of his goods. Now we all know that the best goods in the world may be sold by salesmen who are themselves the worst enemies of their own goods. Personality indeed is a factor which cannot be overlooked, but the trouble with too many people is that they think of salesmanship as playing one's personality without much reference to the goods or their merits. It is this pernicious idea which wise business men of to-day are fighting.

Definition of Business

The thought to-day is that business should consist of free and fair exchange, by means of a mechanism termed money, in virtue of which those who do their share of the world's work are entitled to obtain, and may, in fact, obtain their due share of the things not produced by themselves, which they need for their comfort or satisfaction. This conception of business is the modern conception, but it is also the most ancient. All business began as barter, and the dog-fight conception is merely a diseased belief which sprang from the crazy materialism of the eighteenth and nineteenth centuries, a materialism which is still to be felt among us and which still animates the more vulgar and cunning among business men. It is, however, as certain as anything in the world that the wise among business men everywhere recognize that the object of business is primarily to serve the world and only secondarily to make individuals rich in money and goods. The second aim is bound to follow the first, if the first be scientifically carried out; but it is the first aim, the service aim, which matters to the world and which to-day is understood to be prime and foremost.

Salesmanship Is Service

If this means anything it means that salesmanship first of all is service. It is the process whereby men and women are put in possession of the things they need. Civilized life is so complex that the machinery of exchange can only be run by the constant application of salesmanship, which is the presentation of propositions for the exchange of goods for money. In reality, of course, it is simply goods for goods, the money merely being a part of the system of exchange.

Built by Engineers with the highest Engineering Skill

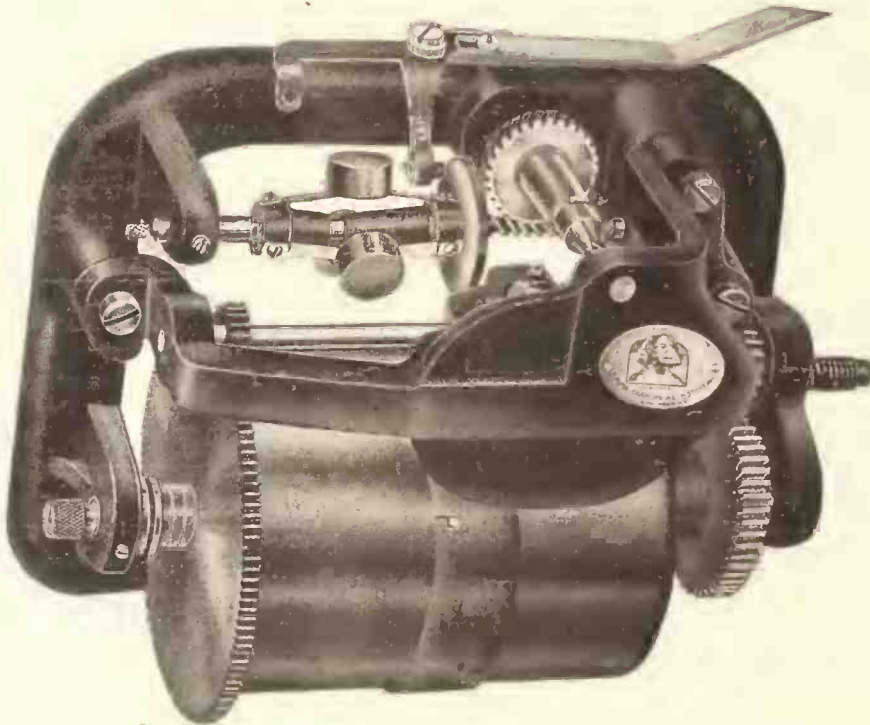

- 1 Designed to stand the strain of hard usage.
- 2 Built to run smoothly and noiselessly under varying conditions.
- 3 Operated with uniformity, and constant in speed.

Write for
Prices



Write for
Prices

Sphinx Gramophone Motors Inc.

21 East 40th St.
NEW YORK CITY

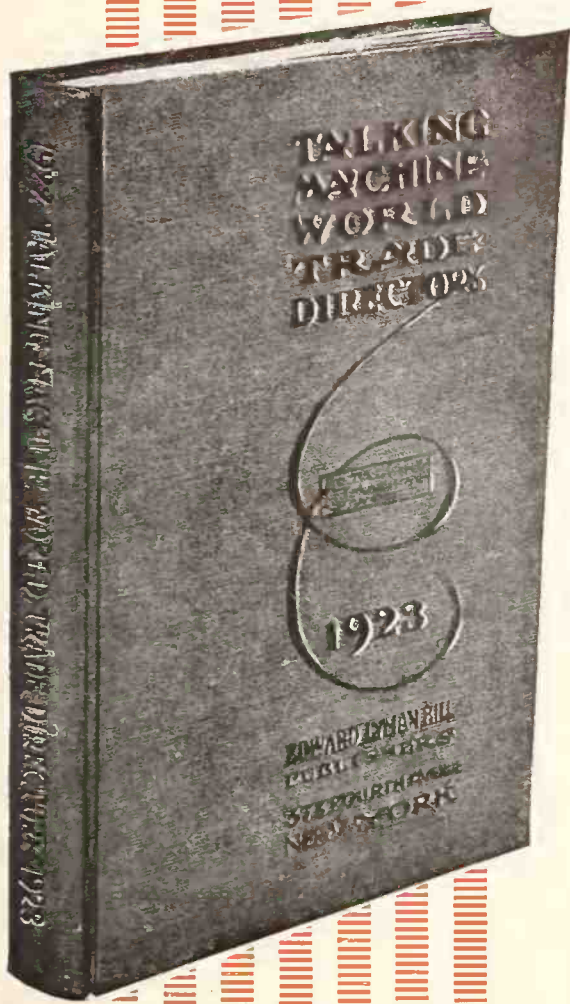

IMPORTANT!

The work of preparing the 1923 edition of the TALKING MACHINE WORLD TRADE DIRECTORY is going ahead rapidly, and this year's DIRECTORY promises to far excel in every detail the 1922 edition.

The advertising forms of the 1923 DIRECTORY will close February 15th. Advertising space in the 1923 edition will *be limited*, and if you have not yet reserved space we would urge you to do so *now*.

A circulation of at least 10,000 for the 1923 edition is assured. This book will be used as a buying and reference guide for the next twelve months, and it therefore offers manufacturers an exceptional opportunity to secure effective, valuable advertising at a very low cost. Advertising rates on request.

If you are manufacturing or distributing any talking machine product, you should be listed in the TALKING MACHINE WORLD TRADE DIRECTORY. This service is free. Send for data sheets if you desire to be listed.

Edward Lyman Bill, Inc.
373 Fourth Ave., New York, N. Y.

In bond selling it is recognized that salesmanship consists of exchanging income and security for money. In the motor car field the process deals with transportation, plus or minus luxury. In real estate salesmanship the motive power is the idea of home owning and independent family life. And so on. The wisest business men are more and more coming to look with a sort of contempt upon the purely speculative side of business and to see that the great thought for to-day and for the future is that of rendering service to the world. The faint heart need not fear that he will starve. The economic history of the modern day shows clearly that the world will richly reward those who have something that the world needs, provided that scientific salesmanship is applied to bring the world and the needed thing together.

Where Our Business Comes In

All this applies to the talking machine business most clearly, sharply and positively. For the talking machine business is concerned with rendering to the world a most important and needed service, the service of music. All popular art is the expression of the feelings of all the people. Whatever art flourishes most at any epoch may be taken to be a fairly clear expression of the feelings and beliefs of that epoch. To-day music is the one art which shows real activity, real liveliness. Music is the modern art par excellence; which is simply another way of saying that to-day music, more accurately than any other form of expression, meets the unspoken but deeply felt needs of the people. That is why the people want music, and why they will have it at any cost. Now the talking machine is of all music gives the most generally useful. It is the unsurpassed music means for the home. Everybody wants it who has not already got it and those who already have it want more and more of its music. If any one exists who neither has nor

wants a talking machine that person is either stone deaf or in need of an interview and a demonstration. If every merchant who sells music in any of its forms were really convinced of these truths there would be no need to say a word about salesmanship.

Equal Profits to Each Party

No trickery, no sharp dealing, no lies, no exaggerations are needed in selling talking machines. The process is the nearest approach yet discovered to that perfect barter which gives equal profit to each party, profit equal in degree though different in kind. If every talking machine man would realize that he is really in the position of being able to benefit everybody who does business with him he would feel sorry rather than sore when a sale was missed, for he would see that the prospect had failed to connect up with a benefit due him, rather than that the salesman had failed to do some bit of sharp work. The careers of those who to-day are selling talking machines and records in the largest quantities are the careers of men who understand that they are selling music, and that to sell music is the most honorable of occupations, for it is the one occupation which need never bring regret.

Moreover, and lastly, salesmanship being the process of putting through equitable exchanges music salesmanship need never be conducted as if price entered seriously into the question. To offer "bargains" in talking machines or records is to do the most unnecessary thing in the world. Every legitimate talking machine or record is cheap at any reasonable price.

Not perhaps all at once will new conceptions conquer and persuade every one, but these new conceptions of business, which in reality are very old, are gaining ground with such rapidity that he who does not lay hold on them now will soon be miles behind in the race.

USES PUBLICITY AS SALES INCENTIVE

H. C. Grove, Inc., Features New Process Columbia Record Advertising—Sales Totals Materially Increased as Result of Drive

WASHINGTON, D. C., January 7.—H. C. Grove, Inc., well-known Columbia dealer in this city, took full advantage of the recent newspaper campaign sponsored by the Columbia Graphophone Co. in behalf of Columbia New Process records. Trimming his window with New Process record advertising copy and featuring

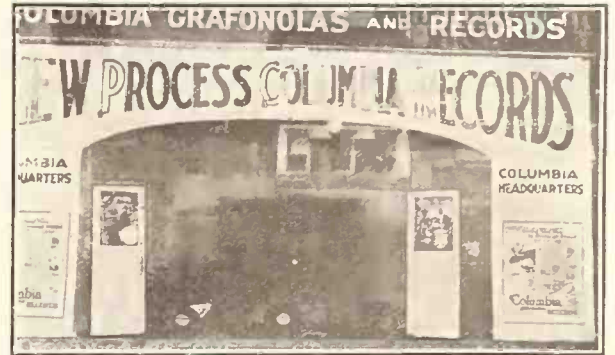

Grove Features Columbia Records

the full newspaper page in his display, Mr. Grove reports that hundred of records were sold to new customers on the day that the advertising appeared. This publicity, moreover, not only produced sales for this particular day, but for weeks afterward H. C. Grove, Inc., lined up new customers on the strength of this New Process record publicity.

MOVES TO NEW LOCATION

PITTSFIELD, MASS., January 8.—John P. Middleton, Victor dealer of this city, has moved his business to attractive and spacious quarters in the Syndicate Block.



Showing Reproducer of Jewel Needle Equipment Turned Up to Change Needle; Also Position When Not in Use



Showing Reproducer of Jewel Needle Equipment in Position for Playing Edison Record With Fibre Needle.



For The New Edison

NOT

Just Another Equipment

BUT

a distinct improvement in Tone Reproduction as well as in Mechanical Construction and Finish.

Send for descriptive circular which contains "HINTS REGARDING THE CARE OF A PHONOGRAPH."

WRITE YOUR EDISON JOBBER. HE HAS IT.

Price the same. Liberal discount to dealers.

GUARANTEED IN EVERY WAY.

MONEY BACK IF NOT SATISFIED.

We handle highest grade Jewel Point Needles.



Showing Reproducer of Jewel Needle Equipment in Position for Playing Lateral Cut Records on Edison Phonograph



Showing Back View of Jewel Needle Equipment in Position for Playing Lateral Cut Records on Edison Phonograph

Plays all types of records. Operates the same as the "EDISON" with the LEVER.

No adjustments necessary when changing from lateral to vertical cut records. Stop prevents swinging to the right.

Needle scratch almost entirely removed.

Turning back of Reproducer permits of easy access to needle socket and saves records from unnecessary scratching.

Is the ONLY equipment that plays vertical cut records with a Fibre needle in the proper "EDISON" position with the Reproducer turned FACE DOWN to the record, giving it a floating action.

Needle CENTERS on all records.

Straight air-tight construction and absence of movable joints insure perfect reproduction and great volume.

Pivoted ball-joint insures perfect reproduction and freedom of movement both vertically and horizontally.

Weight is the lightest that can produce perfect results, thus saving the record, and permitting a freedom and sweetness of tone considered impossible.

Indestructible NCM-Y-KA diaphragms do not blast, crack, split or warp, and are the greatest development in phonographic sound reproduction in years.

JEWEL PHONOPARTS COMPANY

160 W. Whiting St., Chicago

CANTON, O.

Fine Holiday Trade—Foreign Records in Demand—Klein-Heffelman-Zollars Dividend—The News

CANTON, O., January 3.—Holiday business exceeded the fondest expectations of optimistic dealers in greater Canton. Moderate-priced merchandise was in most demand, but, from all reports, there were many high-priced machines sold during the month. One of the most discouraging factors at Christmastime was the inability of dealers to get all the machines they wanted. In some instances stores would have done considerably more business had certain models been available.

"Demand for foreign records is still heavy," Sam Mirkin, manager of the Canton Music Co., said. "Especially wanted are German records of the more popular strain." He declared that hundreds were purchased for Christmas gifts among the large foreign colony of Canton and that not in the history of the concern had the holiday record business been so brisk. The Canton Music Co. is the only store in greater Canton featuring foreign talking machine records.

Jacob Piper, prominent Canton banker, announces that work has been started on a new arcade at Tuscarawas street, E., and Walnut avenue, S. E., which, when completed, will house more than twenty specialty shops, including a modern music store.

Mrs. C. M. Alford, of the Alford & Fryar Music Co., this week announced that never in the history of the trade had Okeh record sales been as brisk as during the two weeks previous to Christmas. Sales of Gennett records this Christmas season were also very satisfactory.

Phonographed while you wait. This might be the working motto of J. J. Warner, who

operates a recording laboratory here, where a number of Cantonians recently have had their singing and talking voices put into permanent form. A novelty just developed by Warner permits recording of the voice on a thin disc that can be accommodated on an ordinary postal card and a number of people sent them as Christmas greetings to their friends.

The Klein-Heffelman-Zollars Co. has declared the regular quarterly dividend of \$1.75 per share on preferred stock, payable January 1. This concern handles Victor talking machines and records and maintains one of the largest piano sections in this part of the country.

The Better Stores Co., new department store on Market avenue, has installed the Playertone line of talking machines and in a window display last week featured the new models of this machine.

Jesse H. Barnes, for several months with the Armstrong Hardware Co., New Philadelphia, O., has joined the sales forces of the Rhines Edison Shop at Massillon, O. Mr. Barnes won the distinction in 1921 of having sold the most Edison machines in the New Philadelphia district.

Prediction is made by C. M. Alford, Canton distributor, that the present year will be one of the most active for the Cheney talking machine in its history. Mr. Alford also reports that the Starr phonograph showed substantial gain in sales in 1922 and that he planned to feature this machine more than ever this year.

So heavy has been the talking machine business at the store of the William R. Zollinger Co. that officials of the company are contemplating adding new booths, according to Manager Pyle of the department. He said this week that for several weeks so heavy has been the record business that as many as five machines at one time have been in use on the sales floor demonstrating records. A gain of 50 per cent over last year is reported by this store in Victor machine sales.

A marked improvement in sales of the Sonora

phonographs is reported in Canton by the Van Fossen-Smiley Piano Co., sole distributor of this phonograph in Canton. Shortage of some models retarded sales to some extent, it is reported. According to Mr. Van Fossen, Vocalion record sales were so heavy that the department was almost cleaned out at the wind-up of the Christmas shopping season.

SUFFERS FIRE LOSS IN OMAHA

Blaze in Adjoining Building Damages Musical Instrument Stock of A. Hospe Co.

OMAHA, NEB., January 6.—A fire which broke out in the Woolworth five and ten-cent store, 401-5 West Broadway, this city, recently seriously damaged the stock in the music store of A. Hospe at 407, just across a small alley, although the building itself was saved from any considerable damage. When it was seen that the fire was threatening the Hospe building workmen began moving the stock and a considerable part of it was moved before the fire became too fierce to allow of their continuing the work of saving the stock.

COLUMBIA DEALER ELECTED MAYOR

R. T. Kingsbury, President of G. H. Tilden Co., Elected Mayor of Keene, N. H.

KEENE, N. H., January 8.—R. T. Kingsbury, president of the G. H. Tilden Co., of this city, exclusive Columbia dealer, has been elected mayor of this city. Mr. Kingsbury has for many years been identified with practically every civic movement in the city of Keene, and a little over a year ago was instrumental in putting over a most successful drive calling for a considerable sum of money for the erection of a hospital. Mr. Kingsbury was active in all war work and his election as mayor is a fitting tribute to the spirit of co-operation that he has manifested toward his fellow-citizens.

IT PAYS TO PUSH HALL FIBRE NEEDLES

The one needle that makes tone—that cannot possibly injure the record—is naturally a necessary accessory of the TALKING MACHINE BUSINESS. YOU NEED HALL FIBRE NEEDLES in your business to give satisfactory service to your customers.

HALL MANUFACTURING CO.

Successors to B & H FIBRE MFG. CO.
33-35 W. Kinzie St. Chicago, Ill.



Date.....
Jobber's Name
Address
Gentlemen:—Please forward via.....
..... CARTONS COMBINATION HALL FIBRE NEEDLES
25 pkg. No. 1—50 pkg. No. 5.
..... CARTONS NO. 5 PACKAGES HALL FIBRE NEEDLES
100 pkg. in carton.
..... CARTONS NO. 1 PACKAGES HALL FIBRE NEEDLES
50 pkg. in carton.
DEALER'S NAME
ADDRESS



Buy from the two largest jobbers in the country ~

NEW YORK
TALKING MACHINE CO.
521 West 57th Street

A.D. Geissler
President

CHICAGO
TALKING MACHINE CO.
12 North Michigan Ave

Victor Wholesalers Exclusively

Mid-West Point of View

WESTERN DIVISION OF THE WORLD, CHICAGO, ILL., JAN. 8, 1923.

EIGHTEEN years ago the first number of The Talking Machine World saw the light. It was pretty small compared with the heavyweight on one of whose pages these words appear. But its editors had some advantages. They did not have to look backwards, as their first number came forward in the new year of 1905 when European wars seemed impossible and the talking machine business seemed to furnish a very small field for a trade paper to enter. No! Number One did not have to look backwards and wonder why the last year's business was not bigger than it had turned out to be; because, you see, there was no last year so far as that journalistic infant was concerned. But we—eighteen years later—we have a lot to look back upon. We have something to regret, no doubt, but we have much, very much more to make us feel pleased. For at this very time, entering upon the nineteenth year of this big paper, we look forward and see, in the light of past experience, the talking machine business reaching forward to heights and depths which once would have seemed inconceivable. We have the past to teach us what the future may have in store for us. And that past is uniformly encouraging, on the whole. So many wonderful things have happened since January, 1905, in this talking machine business of ours, that one can hardly consider any prediction for the future too unlikely or exaggerated. Looking forward into 1923, we can see ahead only happy activity in a trade which is standardizing itself along sane lines. Business has been stimulated by the growing national interest in music, and kept going by the experience-bought wisdom of merchants. Merchants and manufacturers are working together in harmony, and in the light of the prosperity thus foreshadowed the new year has opened auspiciously.

WHEN we spoke above about The Talking Machine World entering on its nineteenth year we were not thinking about other anniversaries that might be coming along at the same time, or else we might have mentioned the very interesting fact that the fiftieth anniversary of the Widdicomb Furniture Co., in Grand Rapids, is being celebrated. Widdicomb was a name known for beautiful furniture for many years before it became associated with phonographs. Upon engaging in the manufacture of these instruments the name Widdicomb was early heard of in the development of console and period models, which have now become so popular. Widdicomb work has here left its impress upon the present trend of design and thought. This is, of course, natural enough, for the Widdicomb tradition was ever solidly on the side of the best in workmanship and in design alike. It is always interesting to note the outstanding sign posts in the development of a great business house, which is always, of course, the outward expression of the mentalities which control it. President Griswold and Secretary Guest are accorded our congratulations.

ALTHOUGH for some reason or another one does not hear so much of the doings of the Starr Piano Co., maker of Starr phonographs and Gennett records, as of some other houses, yet it is a fact that there are few concerns in the talking machine business which get so much work done with so little noise. The Gennett record service is said by those who utilize it to be unusual in promptitude and efficiency and they profit very much by this excellent service and even more by the generous billboard and street car advertising which greets one everywhere one goes in Chicago, telling of the merits of the goods produced in Richmond, Ind. The Starr name was of course not only well, but extremely well and favorably, known in the piano trade for many years before phonographs were thought of as articles of commerce. Starr piano history, if we are not misinformed, begins at Richmond, Ind., in 1872, and that

was seven years before the first machine of Edison. Now Starr phonograph work has been built up on the same high level as Starr piano work. The Starr organization is one to be proud of, and the Gennetts, who carried on the work of Benjamin Starr, have, to the credit of their efforts, a business structure firmly founded. When we spoke of anniversaries we might have included the Richmond institution, too, for from 1872 to 1922 is fifty years, if our arithmetic be not at fault.

WE are sorry to see our good friend H. B. Levy going to the Vocalion headquarters in New York, for this makes just another good man sucked into the greedy maw of Babylon-by-the-Sea. He is a very able salesman and has looked after the interests of the Aeolian Co. here with marked success. The man who succeeds him as head of the new Vocalion Co. of Chicago is well fitted for the job of being his successor, which statement means a good deal. When, however, we go on to say that the man we have in mind is F. W. Clement, the reader who knows the mid-West trade will know that no mistake has been made. Mr. Clement has worked his way up through many a hard knock. He began with the Emerson records years ago when they were the little six-inch fellows. His first catalog had nineteen numbers in it. From that to the mid-West guardianship of the vast Vocalion interests seems quite a jump, but Mr. Clement has been working his way steadily along and the steps he has taken have been many. He is a good man and we are glad to see him in his new post. May he have a big success, and may the activities around Vocalion headquarters on South Wabash be swift during the whole of 1923.

ONE does not like to say how many years ago it was when F. D. Hall first took a bit of bamboo and fashioned it into a talking machine needle, so as to see whether thereby he could diminish the scratch and improve the tone. Doubtless many other men had tried similar experiments, but one man came along, in the fullness of time, who not only tried it but had the foresight and acuteness to see that he had hit upon a great commercial possibility, where the world might be benefited and the perfecter of the idea very justly enriched. It is seventeen years since Mr. Hall, with the idea developed into practical shape and capable of commercial production, organized a company to put a fibre needle on the market. Today the Hall Mfg. Co.'s agents seek for bamboo throughout the Far East, and the inventor sees his products turned out by the millions each year. Only a short time ago Fritz Kreisler thought it no derogation to his dignity to say that he prefers to hear his violin records by means of Hall fibre needles. It has been a good long task, but the result has been worth while. The fibre needle has been one of the real developments of the age and F. D. Hall can feel proud of his accomplishments.

OUR news man, going his rounds, picks up all sorts of queer little items. Many of them are not only queer but funny. All are at least interesting. Here is one which combines all these elements in varying proportions, pointing to an important trade development. No less than four different supply houses where our news man called, on a single day recently, told him that orders are coming in, not rapidly, but very steadily, from China and the Far East, for tone arms, reproducers, motors and other accessories. It is true that the more prosaic statement was added that Australia and South America are buying quite freely of the same goods. Now, talk about Chinese phonographs always provokes a snicker. But talking machines are being made in the Celestial land. It is interesting to note, and significant, too, that in these foreign countries from which our supply houses are getting large orders these days The Talking Machine World has a big clientele of readers.

Eighteen
Years
Ago

Recent
Vocalion
Changes

Widdicomb's
Golden
Jubilee

The Idea
and
the Man

Quiet,
Strong and
Efficient

Increasing
Foreign
Demand

From our CHICAGO HEADQUARTERS

REPUBLIC BLDG., 209 SOUTH STATE ST TELEPHONE WABASH 5242

EDWARD VAN HARLINGEN

WILLIAM BRAID WHITE

EUGENE F. CAREY

ARTHUR E. NEALY

A. SNYDER

CHICAGO, ILL., January 8.—So endeth one year and beginneth a new one—but what a vast difference between the beginning of this new year and the one just past. As everyone remembers the beginning of last year found the trade way down in the trough of depression, whereas the beginning of this year finds it again practically stabilized. The chaotic conditions have practically ceased to exist; a statement which is also true of railroad strikes and labor strifes.

The holiday business, we can safely say, exceeded anticipations and the only thing that kept joy from rising to its highest heights was the fact that, as usual, the majority of the dealers failed correctly to anticipate holiday requirements. Consequently there was more or less shouting and clamoring for last-minute orders, to which the manufacturers in nearly all instances had to turn a deaf ear. Most of them were working to capacity and could find no time to take care of last-minute rush orders. If some inventive genius could develop some method which would cause dealers to anticipate holiday requirements, he no doubt could easily sell his idea for a million dollars. What is really wanted is something which will cause the dealer to realize that when a manufacturer fills an order he cannot go out and pick the goods off the tree, wrap them up and throw them into the mail box. To build a high-grade instrument requires months of work, but strange as it may seem, though many dealers know this to be a fact, they pay no attention. If they would only remember and begin order-

ing for Christmas delivery at least two months in advance they would be in a position then to take care of any trade development and would make more money by far.

When one wanders around the trade he hears on every side suggestions and comment as to what will prevail during 1923. Nearly everyone is of the opinion that 1923 will show a good steady business. It is not believed that there will be any price cutting, but it is believed that if there does happen to come a change in price it will be by way of an increase. It is also believed by many that the majority of the big manufacturing institutions will make radical changes in the architecture and mechanical equipment of their instruments during the new year. Just what these changes will be no one seems to know or to be able to offer a plausible suggestion. Nevertheless, it is believed something of the sort is bound to happen ere long.

A Very Tidy Sum

It is conservatively estimated by the business men of Chicago that Chicagoans spent \$100,000,000 on Christmas merchandise. It is also estimated that the Loop alone contributed something like \$80,000,000 of this vast amount. The balance was scattered throughout the outlying districts.

It is also estimated by leading business men here that one-fourth of this tremendous amount of money was spent for musical instruments, furniture, household articles. The talking machines stand out very prominently among these and every dealer around the city has reported exceptionally brisk sales. Every business man

is positive that the holiday sales cast correct shadows of coming events and is therefore looking forward to a banner year during 1923.

One incident worthy of mention was noted repeatedly throughout the trade and it is that many of the dealers not only incorporated the spirit of Christmas in their windows, but called the public's attention to the fact that in nearly every home there is such a person as mother. It is the first time this point has been so prominently brought out, among not only talking machine dealers, but dealers in every other line as well. It seems that in bygone years the wants of every one of the family have been looked into carefully before presents were bought, whereas in mother's case she was always regarded in a different light. It was the idea that the only kind of a present she would like would be something which would make her more efficient in her household duties. Consequently mother was invariably given a carving set, a vacuum sweeper, or a washing machine, but very few ever thought of giving her something which would tickle her vanity. This year, however, mother was placed in the sweetheart class and she was given other things besides working tools.

The talking machine men, like a great many other dealers, developed this idea this Christmas and in order to put it over filled their windows with talking machines, pianos and other musical instruments. These were all wrapped up in pretty tissue paper coverings, held together with ribbons and carrying

(Continued on page 104)

THE ORO-TONE

This Arm is adjustable in length from 8 to 9½ inches, and adjustable in height up to ½ inch.

Extremely sensitive ball bearing swing or arc.



THE ORO-TONE O-1 CONCERT REPRODUCER

Produces a deep, rich tone quality with great carrying power and splendid definition.

MAY WE SEND SAMPLE ON APPROVAL AND QUOTE PRICES?

THE ORO-TONE O-G CONCERT ARM With Angle Throw Back Improvement

The Last Word in Scientific Tone Arm Reproducer Construction

If you are in the market for a tone arm combination that has splendid eye value, that is perfect in operation, that produces a powerful, deep rich tone quality, that will give continuous service free from complaints, you will be interested in a personal inspection and demonstration of this concert equipment which we are offering at a price that we believe will appeal to you in connection with quality first standards.

DESCRIPTION

No. 16, base; No. 15, large elbow; No. 5, adjustable length extension; No. 6-9, floating throw-back elbow; M, height adjustment screw; L, single ball bearing; S, fixed stud in large elbow; E, stop screw for swing or arc of arm, also hold base to large elbow; C, length adjustment screw; H, assembly screw for No. 4 telescoping extension and 6-9 throw-back elbow; I, hard fibre washer to insure perfect joint alignment and prevent shake or rattle; G, lock screw to prevent assembly screw (H) from working loose.

THE ORO-TONE COMPANY

1010 George St., Chicago, Ill.

Manufactured in Canada under the trade name of ORO-TONE-BANFIELD by W. H. Banfield & Sons, Ltd., Toronto.

FROM OUR CHICAGO HEADQUARTERS—(Continued from page 103)

Christmas cards on which was written "From Dad to Mother," "From John to Mother," "From Mary to Mother," etc. Many of the dealers who carried windows such as this stated when interviewed by a representative of The World that these windows in many instances were the means of closing sales that had been hanging fire for months. They also stated that the windows induced even people who were not prospects to come in and buy and they are all happy to say that the mother idea was a tremendous success and will be again put into play each holiday season hereafter.

Chicago Talking Machine Co. Activities

Walter Geissler, of the sales force of the Chicago Talking Machine Co., reports that the spirit of optimism reigns supreme throughout the aforesaid organization. "Victor business was far greater than we anticipated," said Mr. Geissler, "and we are looking forward to a wonderful year during 1923. Our dealers are also very enthusiastic over the results of their holiday business. They report that their accounts have been making larger cash and larger instalment payments and that the amount of the average sale is higher than ever before." The record business has been exceptionally good and Mr. Geissler attributes this to the increase in special numbers that the Victor Co. has been releasing each month.

W. C. Griffith, assistant sales manager of the Chicago Talking Machine Co., returned from a holiday visit which he spent in company with his wife at his mother's home in Indianapolis.

T. W. Williams, of the sales force of the Chicago Talking Machine Co., with Mrs. Williams, is spending a week's vacation at Little Rock, Ark., where the couple went to visit the mother of Mr. Williams.

New Columbia Stores Opened

The Milligan Music Shop is the name of the new talking machine store recently opened at

3160 North Clark street by E. H. Milligan, who is very well known in the local talking machine trade. Columbia Grafonolas and records are being handled exclusively. The decorations are of the most modern type, including hearing booths, record racks and counters.

Another new Columbia store is the Music Box, located at 656 East Seventy-fifth street—practically in the heart of the Grand Crossing business district. Proprietor Silverstrom is of the opinion that ere long he will have one of the busiest music stores in that locality.

C. R. Johnson is the new proprietor of the Columbia Shop at 2941 East Seventy-ninth street. He has purchased the interest of the former proprietor, E. W. Albro, who opened this shop several months ago.

Opens Chicago Headquarters

A. J. Cullen, mid-West representative of the Hallet & Davis Piano Co., Boston, Mass., has opened headquarters at 341 South Wabash avenue, where can be seen a complete line of Hallet & Davis talking machines, including some very artistic upright and console models. In conjunction with the line of talking machines a full line of Hallet & Davis pianos, including upright, players and reproducing grands, is being carried. Mr. Cullen will travel from his Chicago headquarters at intervals and will call on the trade in the surrounding States.

Schaaf Home Robbed

Harry Schaaf, president of the Adam Schaaf Piano Co., Victor and Edison dealer on "Piano Row," was awakened in his home at 3334 Drexel boulevard the other morning by Mrs. Schaaf, who complained of the odor of chloroform. Mr. Schaaf made an investigation and discovered that thieves had gained entrance through a second-story window and had stolen jewelry and other valuables. Mr. Schaaf believes that the second-story men were familiar with the layout of the house and that the rob-

bery was planned long in advance. This conclusion was arrived at after Mrs. Schaaf recalled that numerous telephone calls have been received during the night for the past year and she believes that in this manner the burglars tried to ascertain the hours at which members of the household were accustomed to retire.

Old Magnola Employee Dies

John Cepak, one of the oldest local musical instrument workers and an employe of the Magnola Talking Machine Co., died suddenly at his home on December 18. Mr. Cepak had been continuously in the employ of this concern for over twenty years. He is survived by his widow, two children and a brother, Alderman Joseph Cepak, of Chicago.

Demand for Cover Supports

A great number of inquiries have been received from the trade by R. N. McArthur, sales manager of Barnhart Bros. & Spindler Co., about the "Superior" lid supports made by this concern. This lid support is one of the first known of its kind on the market and is a spring-balanced mechanism which does not warp the lid. It is so constructed that when the lid is closed a steel roller fits into a notch of the track arm, which in turn prevents the spring from exerting any pull on the lid while it is down. When the lid is all the way up the spring is not in tension. The Superior lid support is so carefully balanced that a mere touch of the finger suffices to lift or close the lid, and perfect balance is maintained at any desired position. The Superior lid support was first offered to the trade several years ago and has been a favorite among many manufacturers ever since its introduction.

How to Locate Good Prospects

The license bureau of the city of Chicago gave out the news last week that 37,000 couples in Chicago were united in marriage during the year. These records are always available to



"Built by tone specialists"

IN ITS SEVENTH YEAR OF STEADY SUCCESS

4 Cabinet Styles:

Mahogany, Walnut and Oak Finishes.

Patented Tone-Deflecting System:

Unsurpassed Workmanship.

Vertical Record Filing:

Mechanical and Acoustic Equipment Beyond Criticism.

Write for our *Revised* Wholesale Prices

Magnola Talking Machine Company

OTTO SCHULZ, President

711 Milwaukee Avenue

Chicago



Magnola Style Louis XVI

FROM OUR CHICAGO HEADQUARTERS—(Continued from page 104)

anyone who cares to look at them and some of the progressive dealers in this city do take advantage of this opportunity of going after the happy couples as prospects. The same proposition is applicable to real estate records and many of the dealers here are always on the job finding out what families are purchasing new homes. Good work!

New Brunswick "Tudor" Console

The Brunswick Co. has just announced a new console model in the English Tudor style, which is another striking testimonial to Brun-



The Brunswick "Tudor" Console Model wick craftsmanship and artistry. As may be noted in the illustration it is a design of real beauty. A. J. Kendrick, general sales manager of the phonograph division of the Brunswick Co., in commenting upon the new model predicts a great demand for it and believes it will be as popular as the York console. It is equipped with the usual Brunswick features, such as the Ultona, the oval all-wood tone arm, three-spring Brunswick motor, automatic stop and six record albums with gold plated trimmings. Until further notice, according to Mr.

Kendrick, the Tudor will be available only in two-tone American walnut finish.

Asher's Music Shop Opens

The Mandel Asher department store at Chicago Heights, which recently opened an exclusive Brunswick department, has decided that talking machine business is profitable and has therefore opened a new shop to be known as Asher's Music Shop, at Danville, Ill. This new store is also exclusively Brunswick for talking machines, but it is understood that a full line of music goods and probably pianos will be carried later. Musical instruments are already being handled by this new concern, the company having some time ago been appointed retail distributor for Buescher band instruments in that particular territory. Arrangements are now being made by the parent company to increase its present Brunswick department, and the contract has been let by this company to the Unit Construction Co. for the remodeling, decorating and installation of hearing and demonstration booths.

Cardinal Sales Co. Tonofone Agent

Miss E. E. Powell, secretary of the Tonofone Co., has just returned from a visit to Columbus, O., where she went for the purpose of calling on the trade in that section. While there she appointed the Cardinal Sales Co., of that city, jobber for the Tonofone needle. F. F. Dawson, general manager of the Cardinal Sales Co., was formerly manager of the Sterling Roll & Record Co. The new Cardinal record has made its appearance in the Chicago territory and retails for 75 cents, and Mr. Dawson has supplied all of his travelers with Tonofone needles, which they will sell to their respective dealers.

Lyon & Healy Change Form of Stock Holdings

The stockholders of Lyon & Healy have voted to reorganize the company by transferring all of its property to a new company of the same name capitalized for \$2,500,000 preferred stock and \$4,500,000 common stock. The preferred

stock will be sold to the public and all the common stock of the new company will be exchanged for the holdings of the present stockholders of the old company.

As a result of the reorganization there will be no change in the control of the company, and as a matter of fact M. A. Healy and Columbus Healy have recently materially increased their holdings. The reorganization, however, will permit the sale of common stock to the employes of the company at a reasonable price, and the board of directors expects to inaugurate the policy of making such common stock available for purchase by employes.

There will be no change in the management of the company or in its business policy.

Brunswick Sales Meeting

That part of the sales department of the Brunswick-Balke-Collender Co., which covers Illinois, Indiana, Michigan, Wisconsin and part of Iowa, got together for an annual meeting on December 28, 29 and 30, at the headquarters of the Brunswick Co. The meeting was presided over by B. E. Bensinger, president of the Brunswick Co. Other officials at this meeting were A. J. Kendrick, general sales manager; W. C. Hutchins, assistant general sales manager; H. B. Bibb, district sales manager for this territory; A. L. Fram, manager of the record sales promotion department; R. H. Avrill, manager of the dealer publicity department, and W. D. Montgomery, district manager of the Unit Construction Co.

Plans for the coming year were gone over in detail, when each departmental manager gave an outline of what his department accomplished during 1922 and what it contemplates for 1923. Mr. Montgomery gave the travelers an insight into the methods now being employed by the Unit Construction Co., in order to bring about the greatest efficiency in retail store equipment.

During the meetings luncheon was served

(Continued on page 107)

VITANOOLA

The Phonograph of Marvelous Tone



No. 43—List \$125.00

Write us for DEALER'S price

THE 1923 line, consisting of nine models exquisite in design and adhering in tonal qualities to the high standards that have set apart this instrument as the criterion by which all other phonograph tone is judged, will be shown in Chicago, during the Furniture Market, at

1337 MICHIGAN AVENUE

Included in the new line are a number of models in the new two-tone finish, embodying special features in construction and in the skillful matching of beautifully figured woods.

Dealers who will not visit Chicago during the Market are invited to write for full information concerning the new line and our attractive prices, which enable them to offer their trade a phonograph as far superior to those ordinarily sold at the same price as a Beethoven Classic is superior to the beating of a tom-tom.

Vitanola Talking Machine Co.

Saginaw, W. S., Michigan

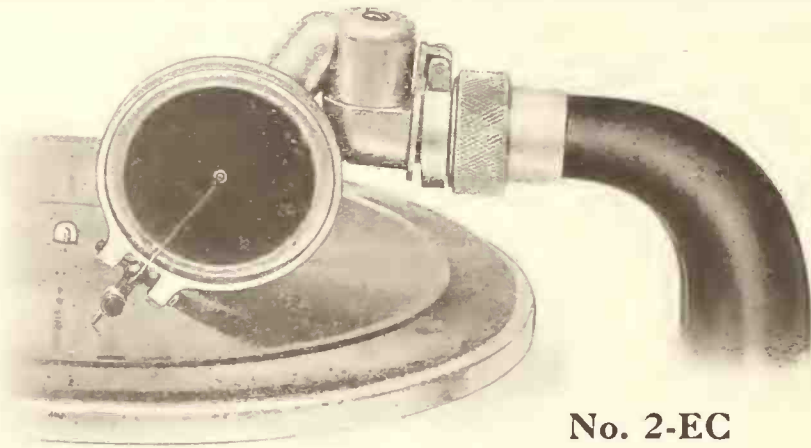

No. 2-EC

Edison Concert Equipment

THE above illustration shows the latest improved Oro-Tone attachment for playing all disc records on the Edison Phonograph. It gives a deep, rich, glowing tone quality and operates with the raising and lowering lever in the same way as the regular Edison reproducer.

Where tests have been made between Oro-Tone equipment and others before audiences who were not informed which reproducer was being used, the choice invariably was in favor of the Oro-Tone.

This is supreme proof of its quality.

Why Users Recommend Oro-Tone Equipment

1. It gives a marvelous tone quality.
2. It is built substantially of best materials.
3. The finishes harmonize with Edison finishes.
4. It permits playing all disc records.
5. It is easy to operate.
6. It operates with raising and lowering lever.
7. The sound box is unquestionably superior.
8. Our special needle box increases convenience.
9. With our E-VR needle it practically eliminates all surface noises.
10. Every attachment is guaranteed for period of 2 YEARS.

Hundreds of our dealers have told us that they have been able to close many sales on machines where the customer hesitated until shown that with Oro-Tone equipment all disc records could be played. You will find, just as these others have found, that with Oro-Tone equipment, you have an unbeatable argument that quickly boosts sales.



Safety Point Needles

Our velvet running safety point needles for Edison and Pathe records practically eliminate all surface noises. You will marvel at the soft, rich, pure tone quality. Each needle mounted on fancy card and enclosed in transparent envelope.

- No. E-VR—For Edison 65c
- No. P-VR—For Pathe 65c

Usual Discount to Dealers

Oro-Tone
QUALITY FIRST

products are guaranteed to be mechanically correct and perfect in operation and are shipped subject to your return if not entirely satisfactory.

List Prices

Packed in Regular Boxes

No. 2-EC—

- Nickel \$7.00
- Gold 9.00
- Oxidized 9.00

Usual Discount to Dealers

The Oro-Tone Co.
QUALITY FIRST

1000-1010 George Street

ASK YOUR JOBBER FOR ORO-TONE EQUIPMENT

Read this letter. Hundreds of our dealers are confining their business exclusively to the Oro-Tone because of the satisfaction it gives to customers.

WHAT ONE DEALER SAID

I must admit that in my eight years experience I have seen no attachments or reproducers that equal the ORO-TONE. Every purchaser is satisfied. My sales of the superb EDISON are easily made when I demonstrate how perfectly it plays lateral cut records - When the ORO-TONE is used

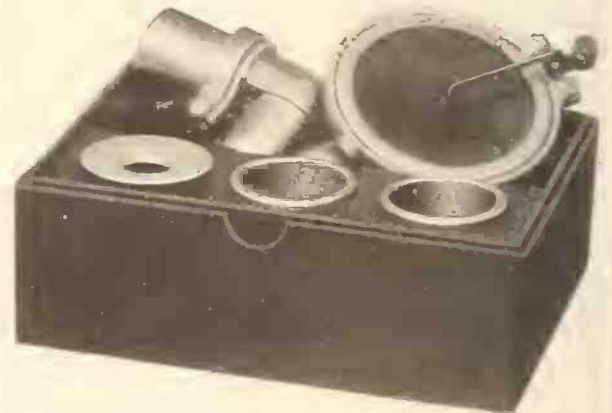

The Oro-Tone Needle Case

To hold needles and the Oro-Tone attachment when not in use, we have designed this beautiful, substantial box. Below also is a similar box for needles only. Made in rich maroon color with gun metal finish needle cups. Very substantial.

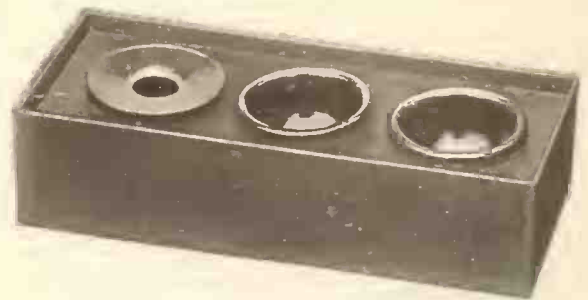

You will find a big demand for these cases. Many customers who already own attachments want one or both.
Case with space for attachment..... 35c
Case for needles only..... 25c

Usual Discount to Dealers

Also Manufacturers of Highest Grade WIRELESS EQUIPMENT

CHICAGO, ILLINOIS

Manufactured in Canada under the trade name Oro-Tone Banfield by W. H. Banfield & Sons, Ltd., Toronto, Canada

FROM OUR CHICAGO HEADQUARTERS—(Continued from page 105)

daily at the Auditorium Hotel. Members of the traveling forces present at this meeting were: Wm. Durgis, H. L. Ferris, R. A. Sweeney, C. A. Moore, Frank Kuthly, A. G. Burr, C. R. Lovejoy, Glenn Stewart, K. McInnis, E. J. Ackerman, P. H. McCulloch, J. A. Carroll and Joe Lyons.

Orotone in Canada

Arrangements have just been made between the Orotone Co., of Chicago, and W. H. Banfield & Son, of Toronto, whereby the latter become Canadian and foreign representatives for the Orotone Co. products. The arrangements involve the manufacture of these products by the Banfield concern, under a special agreement. Banfield & Son also manufacture a line of motors, tone arms and sound boxes, but have decided to adopt the Orotone product. Orotone will now be given first-class representation throughout Canada and foreign countries, and all of this business will be looked after from the Toronto headquarters.

Start Concentrated Sales Campaign

I. Lowenthal, general sales manager of the Burns-Pollock Electrical Mfg. Co., of Indiana Harbor, Ind., has returned to his Chicago headquarters in Room 300 of the Republic Building from a protracted trip through the Central West territory. He reported the trade to be very enthusiastic over the Capitol talking machine lamp, which his company is manufacturing. The activities of these dealers are keeping the Burns-Pollock plant in Indiana Harbor working overtime in an effort to fill all orders. In order to take care of the holiday business it was necessary for this concern to add a night force.

The company has made extensive plans for a concentrated sales campaign, which was put in effect on January 1, and a large number of salesmen were then added to the Chicago sales staff. It is the company's intention to enlarge its present headquarters and it is therefore keeping its eye open for a large ground floor store along "Piano Row."

Brunswick Announces Price Modification

A. J. Kendrick, general sales manager of the phonograph division of the Brunswick-Balke-Collender Co., announces that prices on certain Brunswick upright models have been modified. In making this announcement Mr. Kendrick stated that the Brunswick Co. considers its relation to Brunswick dealers as a partnership and therefore takes the interest of its partners into consideration in this change of prices by allowing a proper consideration on those instruments which the Brunswick dealers have in stock. Brunswick upright styles are still in great demand, surprisingly so in view of the call for console models through the introduction of the more popularly priced types. However, it seems proper that some price modification should be made in some of the Brunswick styles at this time. Therefore Brunswick offers its dealers the new prices, which will naturally add to their attractiveness and undoubtedly greatly stimulate the sales of these models.

The models which will carry this new price modification are known by the numbers 117, 120, 122, 127 and 135. The territories affected by these new prices will be the territory east of Salt Lake City, Utah, and the territory west of Salt Lake City, including Salt Lake City. The modification approximates a reduction of something like 10 per cent.

December Big Publicity Month

December proved to be an exceptional month in Chicago for Columbia publicity. Not only was there a large amount of space devoted to the new Columbia records in Chicago dailies, but quite a number of theatres and other places of amusement aided. This latter publicity was brought about by the Chicago appearance of six exclusive Columbia artists. These were Al Jolson, who appeared in "Bombo" at the Apollo Theatre; Ted Lewis and his orchestra, Nora Bayes, Duci de Kerekjarto, the Hungarian violinist; Frank Westphal and his orchestra and Paul Biese and his orchestra. Frank Westphal

and his orchestra proved to be quite a center of attraction, in view of the opening of the new million-dollar ball room at the Rainbow Gardens. While these artists were playing in Chicago, the local Columbia branch was a very attractive place. This was due to the fact that Columbia equipped a temporary recording chamber at the headquarters of a Chicago branch for the special purpose of making records of the aforesaid artists' playing.

New Columbia Assistant Manager

F. E. Johnston has been appointed assistant manager of the Chicago branch of the Columbia Co. His association with this house has been one of rapid progress since joining the Kansas City branch about six years ago. At that time he came on as a bookkeeper, but it was not long before his efficiency and integrity won him recognition and his appointment as assistant manager of that branch followed in short order. His work there was again recognized and because of the efficient methods instituted by him the Columbia Co. lost no time in promoting him

to assistant manager at the local Chicago branch when that position was made vacant by the recent resignation of Norman B. Smith.

Demonstrates Long-distance Records

A long-distance phonograph which will record sounds made hundreds of miles away was demonstrated to the Society of Western Engineers recently by E. H. Colpitts, of the Western Electric Co. He also demonstrated a device through which five conversations can be carried on over one telephone line, any one being cut out at will by turning a switch.

Harry Engel Visits

Harry Engel, general manager of Richmond-Robbins, Inc., city of New York, was a visitor to Chicago during the holiday week. This is the first time Harry has been in Chicago for several months and as usual he marveled at the way the town has grown in his absence. At one time Harry was Chicago representative for the well-known Mutual Phonoparts Co. and gained a large host of friends here. Harry

(Continued on page 108)

WARNING!

Infringement Notice

THE trade and the public generally are notified of the issue by the United States Patent Office on November 14, 1922, of Letters Patent No. 1,435,660 for Educational Appliance. This patent was granted to Wallace Institute and covers, broadly, the invention of the popular Wallace Records and Charts. All forms of appliances comprising a phonograph record having instructions for physical exercises recorded thereon combined with any sort of an indicator or chart illustrative of such exercises infringe this patent.

Dealers who sell and all who use records and charts of the character above described, unless they be the Wallace Records and Charts, are liable to Wallace Institute for infringement of its patent. This is true whether the records and charts are made by the dealers or some one else.

All dealers are now called upon to cease the sale of infringing devices under penalty of suit for injunction and accounting for profits and damages.

Further Notice also is given that Wallace Institute possesses proprietary rights in and to the trade-mark "Reducing" when applied to talking machine records, evidenced by Certificate of Registration No. 160,758 issued by the United States Patent Office, October 24, 1922.

Dealers selling records under this trade-mark, except they be the Wallace "Reducing" Records, also render themselves liable for infringement thereof.

Violation of the rights above specified will not be countenanced, and warning is given that all infringements will be vigorously prosecuted.

WALLACE INSTITUTE

Chicago, December 1st, 1922



I don't know why I should cry o-ver you, sigh o-ver you, e-ven be blue,

The Big Waltz Ballad Hit

Why Should I Cry Over You

It's Another "I'm Sorry I Made You Cry"

"You can't go wrong
With any FEIST song"

HEAR IT NOW!

FROM OUR CHICAGO HEADQUARTERS—(Continued from page 107)

stated that there was a decided increase in sheet music business during the past six months and this was due to the fact that many talking machine dealers throughout the country are now stocking popular sheet music.

Enlarges Its Manufacturing Resources

The Excel Phonograph Mfg. Co., of 400-12 West Erie street, of this city, has enlarged its working force within the last few weeks by adding a large number of cabinet makers and other woodworking mechanics. The outlook for 1923 is very promising, according to President Axel Nordlund, and the reaction of the trade to the record filing cabinets and small portable talking machines which this company manufactures has been very gratifying. The Excel Co. is also putting out a high-grade talking machine cabinet of upright design which is fitted with a three-spring motor and other high-grade equipment. This instrument is also equipped with the Adams improved record filing system.

Another Use for Talking Machines

In our travels throughout the Chicago territory we occasionally run across some very good ideas wherein the talking machine plays an important part. One of the latest items to come to our notice is being put into operation by Richard Mangold, musical director of the Stratford Theatre, Sixty-third and Halsted streets. Mr. Mangold is a violinist of no mean ability and is very well known as an orchestra director. Being a high-grade musician himself he is naturally very emphatic in the demands he makes upon his orchestra, of which, needless to say, each and every member is a high-grade artist.

In the territory surrounding the Stratford Theatre is the southern part of that section familiarly known as "the back of the yards district." It has always been said that this particular place in Chicago would only tolerate

shimmy and jazz music, but Mr. Mangold has proved to the world that if certain classical numbers are rendered perfectly they will be not only tolerated, but appreciated in all walks of life. He, therefore, started out, something over a year ago, to introduce classical overtures. At first the effect on the box office was depressing, but within a month there was a reversal of this condition and the receipts showed an increase which has been growing steadily ever since. Mr. Mangold has been giving the "back of the yards people" selections from all of the operas and has played nearly every classical number of any consequence.

On Sunday morning he holds his rehearsals and drills his men in their respective parts. After this is accomplished he utilizes a Victor talking machine and then with the aid of a record, which contains symphony or orchestral numbers such as he has been rehearsing, he gets his men to listen to this particular selection, in order that they may thoroughly familiarize themselves with the special educational points contained therein. After this listening-in process is completed Mr. Mangold then rehearses his orchestra again, and, needless to say, there is a tremendous improvement in the playing, as each and every musician gains some individual idea from the record.

Opens Victor Store

A. W. Hanson, who was for several years manager of George P. Bent's Logan Boulevard Shop, has opened a store of his own in Portage Park in the northwest section of Chicago. The new store is a very beautiful one and is fitted up in a most modern fashion, having ten up-to-date hearing rooms and very commodious record bins and counters.

In New Headquarters

Weiser & Sons, exclusive Brunswick dealers at 2106 South Kedzie avenue, have opened a new store at 2100 on the same avenue. The

new store is almost twice as big as the old one and is a corner location. They have completely Unicoed the new place of business and now have a capacity for over 3,000 records. This concern also handles its own make of pianos.

New Brunswick Portable

The Brunswick-Balke-Collender Co. has announced the new Brunswick portable, which will be known to the trade as Style No. 101. This little instrument comes in genuine leather, natural finish, at \$50, and in black leatherette, at



Brunswick Portable Style 101

\$45. The lid is constructed to carry twenty records. These records are held in a special compartment, which may be completely removed from inside the upper lid. The corners are reinforced and held by solid rivets. When this compartment is removed from within the lid the latter may be lowered while the instrument is playing. When ready for traveling the tone arm and winding crank are held securely in place by special brackets placed within the amplifier. The turn-table is ten inches in diameter, but there is plenty of room to play twelve-inch records. The hinges and locks as

UNIVERSAL SAFTEE-SHIPPER

A most simple, compact, economical and efficient device for safely sending small lots of records through the mails and by express.

No wrapping necessary. Ready for instant service as shown. Time of wrapping and envelope cost saved. \$1.20 per doz. Parcel Post-Paid. \$7.50 per hundred. \$69.00 per thousand. Holding either 10 in. or 12 in. records.

The cut-out eliminates the lateral (breaking) pressure!

The cut-out takes the lateral pressure and strain from the record sides. The envelope corners are wedged between the corrugated straw boards and retain the records securely.

UNYVERSAL UTYLYTY UNYTS CO.

6111 Winthrop Avenue

CHICAGO, U. S. A.



Patent Pending

Small Size
From One to Three

A Better Fibre Needle Cutter for Less Money

RETAIL PRICE \$1.00

The ALTO



Manufactured by
ALTO MFG. CO.

1801-1803 Cornelia Ave., CHICAGO, ILL.

FROM OUR CHICAGO HEADQUARTERS—(Continued from page 108)

well as the double corner support are also held in place with solid rivets and in conjunction with the lock for securing the top lid there are also three strong solid brass snaps, two of which are utilized in conjunction with the lock for the top lid, while the third holds in place the door which covers the amplifier.

J. Sallo Opens Second Store

J. Sallo, who has for a number of years handled sporting goods and Columbia Gramophones at Sixteenth street and Vincennes avenue, this city, has secured a lease on the building now being vacated by the Smith, Barnes & Strohber Co. at 66 Illinois street, where he has opened a second store, featuring the Victor Victrolas and records. Smith & Barnes are discontinuing their store in Chicago Heights.

Important Ruling Forbids City Tax

A news item of great importance to the trade, especially to manufacturers' agents, appeared in the columns of the Chicago Herald & Examiner in the issue of December 12. The item, which appeared under the caption "City Tax on Factory Agents Forbidden—Writ Against Collection of License Upheld by Appellate Judges," is printed herewith in full:

"Affirming an injunction against the City of Chicago granted some weeks ago by Circuit Judge Hugo M. Friend, preventing the collection of a \$50 annual fee from 7,500 manufacturers' agents in the city, Judges McSurely, DeVer and Matchett of the Appellate Court decided the city collector has no right to collect the fee.

"The decision cuts off a possible revenue of \$375,000 yearly from the city. The attempt to collect the fee had been based on an ordinance requiring 'brokers' to pay \$50 a year.

"This attempt was resisted by J. R. Lineham, R. W. McGarry, Peter Peterson, Henry Lundesberg and George Tesch, who filed suit for an injunction against the city and the city collector. Judge Friend upheld their contention that the ordinance did not apply to them and the Appellate Court affirmed Judge Friend's decision."

Paul Whiteman's Orchestra Opens Ballroom

Chicago for the first time in its musical history turned out en masse early last month to welcome Paul Whiteman and his orchestra, who came here from New York and played one week at the new Trianon ballroom.

Paul Whiteman and his orchestra, who as everyone knows are exclusive Victor artists, received \$25,000 for their week's work, which amount is believed to be the largest ever paid to a popular dance orchestra for a single week. One of Chicago's dailies, in touching on this particular item, mentions that the twentieth century is kinder than the nineteenth to its musicians. "Witness the contrast in the fortunes of Berlioz two generations ago and of Paul Whiteman to-day. Berlioz predicted great glory for that musician who should realize the possibilities of rhythm. Realizing it himself, he gained great glory, but little else, from ungrateful Paris, while to-day Paul Whiteman revels in artistic, popular and financial affluence springing from his musical insurrection. Whiteman has a distinct advantage over Berlioz, inasmuch as he is learned in counterpoint and Berlioz was not. Berlioz lived before the woodwind and brass instruments had reached the high development and fine subdivisions of to-day."

As a matter of fact, this is all true, because Paul Whiteman knows exactly what the people of to-day want in music. This, in itself, has made Whiteman popular throughout the country, and this popularity to a great extent has been brought about by his Victor recordings.

Thousands of people who visited the Trianon during Mr. Whiteman's stay here are now in a position to appreciate what a splendid organization he conducts and were able to appreciate how faithfully his records portray his art. This fact has been educational and proved a boon in expanding the trade in talking machines in Chicago.

The Trianon is said to be the most beautiful ballroom in the world and cost more than a million dollars to erect. It is easy to see that the best architectural and decorative thought in the country was drafted for its construction. On the night of its formal opening Chicago's society danced for charity and the occasion was known as the "Bal Fantastique." It was given for the benefit of the Illinois Home and Aid Society and the entire building, its operating forces and Paul Whiteman's Orchestra were donated to the cause.

Mr. Whiteman, in commenting on his reception by Chicagoans, said he believed that his welcome was the warmest ever received by any popular musical organization and he is very enthusiastic concerning the co-operation and good-will extended him by the Chicago Musicians' Union.

On the occasion of Paul Whiteman's appearance here, Ferdinand A. Buescher designed, made and fitted out completely the entire or-

chestra with a set of gold Buescher instruments said to have cost nearly \$10,000. These were used exclusively by Mr. Whiteman and his orchestra every night during his appearance, and to their music three thousand dancers kept step each night. The dance floor of this magnificent ballroom is 100 by 150 feet in dimensions, elliptical in shape and accommodates 1,500 couples.

Unico Activities

W. D. Montgomery, manager of the Chicago division of the Unit Construction Co., made the announcement this week that the size of his territory has been recently increased and that now he is looking after eleven States. The Chicago district will be known after January 1 as the third Unico sales district. Heretofore it has been known as the fifth. The office force has been augmented by the addition of Harry C. Baish, who will assist Mr. Montgomery as senior salesman. Mr. Baish is very well known

(Continued on page 110)

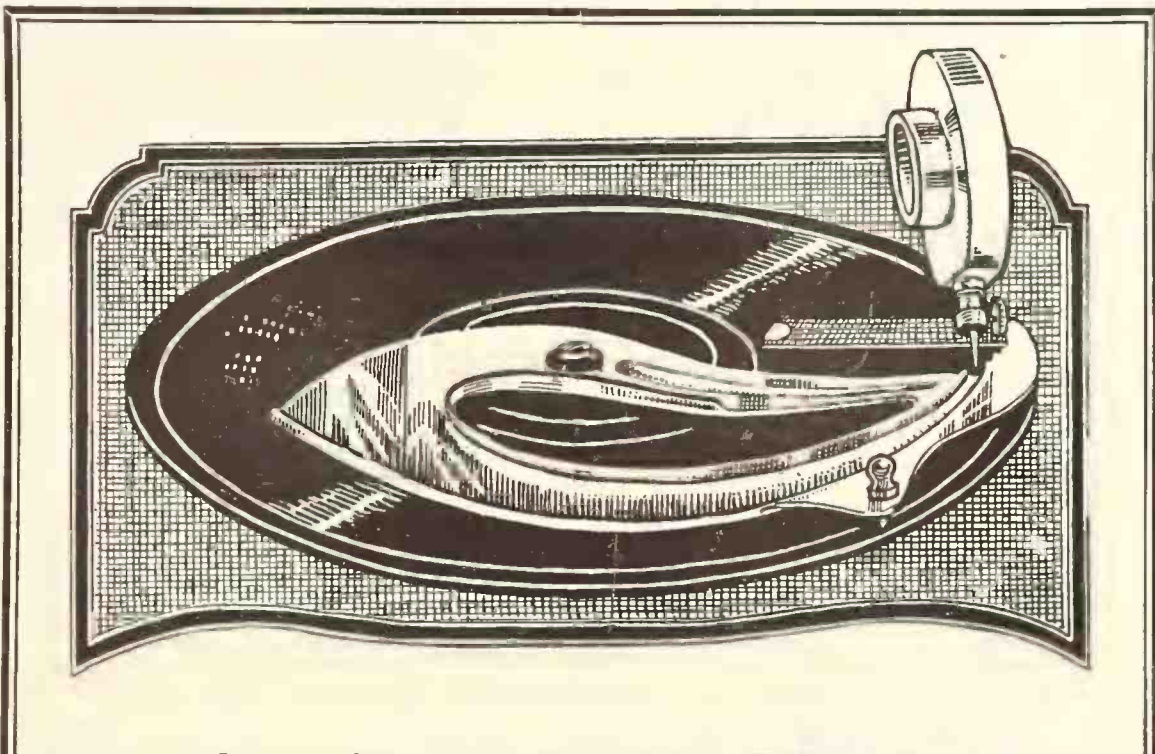

**You Can Talk GEER REPEATER
Quality Without Reservation.**

The Improved Geer Repeater, finished beautifully in genuine gold plate, is meeting with tremendous approval from jobbers and dealers alike. This repeater is in every way quality merchandise. It will last a lifetime, is adjustable, and proves a distinct asset wherever continuous music is desired—at dances, social functions, and in the home.

Old Price \$2.50

New Price \$1.50

WALBERT MFG. CO.

925-41 Wrightwood Ave.

Chicago, Ill.

FROM OUR CHICAGO HEADQUARTERS—(Continued from page 109)

throughout the talking machine trade and at one time was factory representative for the Victor Co. Ill health caused him to discontinue activities for quite a while and it was necessary for him to go to Denver to recuperate. K. E. Withrow will join the force on January 1 in the capacity of junior salesman. This young man has just finished one and a half year's schooling at the great plant of the Unit Construction Co. in Philadelphia.

R. F. Pierce has also been added to the Chicago headquarters of Unico. His duties will be that of installation foreman, and his coming will greatly improve the Chicago branch's service.

Mr. Montgomery also stated that other activities of the Unico will embrace fixtures for jewelry and department stores, and bank fixtures, in addition to their regular line of talking machine shop equipment and radio cabinets. Mr. Montgomery also announced that on December 15 a 10 per cent increase in Unico prices went into effect. This was caused by labor and

LOUD!!!

For Dancing and Band Records

MEDIUM!!!

(The Original Tonofone)

For Voice and Instrumental Records

BOTH ARE

Tonofone

The Needle With A Flexible Point

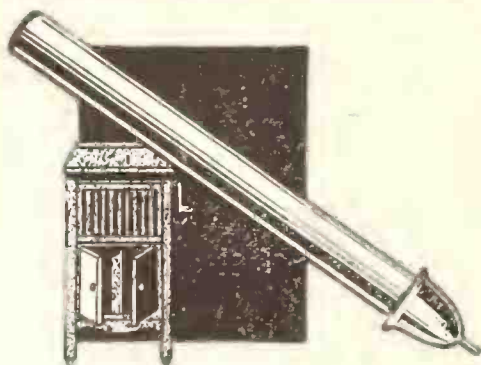

Sufficient volume is now attainable with a quality only TONOFONE can give by the new loud Tonofone. And at the same price and same construction, but LOUD.

TONOFONE alone gives out all that is in the record. This is because of its famous flexible resilient non-scratching point—an exclusive feature of

"Tonofone"

the best needle value ever offered the trade.

Write for samples and particulars—free.

THE TONOFONE COMPANY

110 So. Wabash Ave., CHICAGO, ILL.

Inventors and Sole Makers



Repair Parts

For All and Every Motor That Was Ever Manufactured

We can supply any part. The largest and most complete assortment of repair parts—in the United States—on hand, for old, obsolete and present-day motors. If your order cannot be filled from stock, we will make it up special.

Special prices on main springs, governor springs, micras, repair parts, motors, tone arms, steel needles, etc., in quantity lots.

Expert repairing on all makes of phonographs and motors.

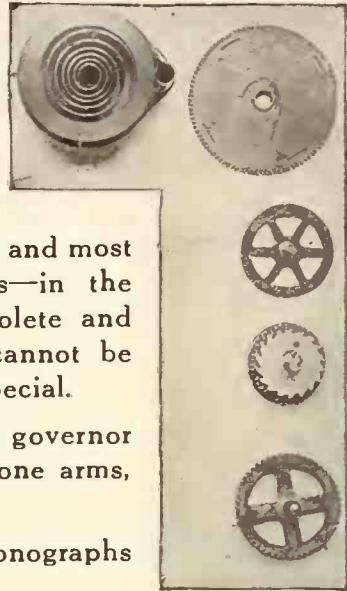

INCORPORATED UNDER THE LAWS OF ILLINOIS

Consolidated Talking Machine Co.

SUCCESSORS TO
Standard Talking Machine Co.
United Talking Machine Co.
Harmony Talking Machine Co.
O'Neill-James Co.
Arelino Co.

Manufacturers of
High Grade Talking Machines, Disc Records,
Talking Machine Supplies, Etc.

227-229 W. WASHINGTON ST., CHICAGO, ILL.
Branch: 2957 Gratiot Ave., Detroit, Mich.



TRADE MARK
"CONSOLA"

CABLE ADDRESS
"CONSOLA"

raw material advances and is a step deemed necessary owing to conditions.

Boosting Sonora

During the holiday season just passed many Sonora dealers throughout Chicago purchased advertising space in the Chicago dailies for publicity on this well-known instrument. One concern, the John M. Smyth Co., manufacturer, retailer and inventor of high-grade furniture, devoted several half pages to Sonora publicity. The advertisements were very artistically arranged with highly decorated borders. Within the design borders was placed a series of figures illustrating the spirit of music. There was also a very elaborate drawing showing one of the artistic Sonora console models. The text matter was directed towards the John M. Smyth Co., and tied up with the Sonora Co. One of the significant paragraphs read:

"We have always catered to a clientele which appreciates quality. Sonora is the synonym of all that the word 'quality' implies. In recognizing this, the John M. Smyth Co. is living up to its high ideals in giving its patrons Sonora—which exemplifies the ultimate in tone."

The John M. Smyth Co. is one of the oldest and best-known Chicago furniture houses, having been established in 1867. Besides carrying a complete line of Sonoras this house also handles a complete Cheney line.

A Little Tip and a Deduction

The Chicago postoffice is putting on a campaign against waste, and placards to this effect have been attached to all mail wagons. It is stated by local postoffice officials that approximately 10,000 direct-by-mail advertising pieces are torn up each day. This amounts to something like 2,900,000 pieces of mail per year

which go to waste owing to illegible, insufficient or out-of-date addresses which make delivery impossible.

During the past year something like 2,697,338,208 pieces of mail went through the Chicago postoffice. About 15 per cent of this was third-class matter, which included form letters, circulars, folders, etc., and it was of this latter volume that 2,900,000 pieces of mail proved to be undeliverable and went into the waste basket. Perhaps this explains why some talking machine dealers in Chicago failed to get results from mail advertising.

Kresge Pathé Display Much Admired

One of the most elaborate and beautiful displays of Pathé Actuelle records ever seen in



Kresge Display of Pathé Records the West was arranged recently for the record counter of a prominent retailer of Chicago and some of the striking effects may be seen in the illustration shown herewith.

It will be seen that there are a great pro-

ROTOMETER

Don't Guess How Fast Your Turntable Is Traveling

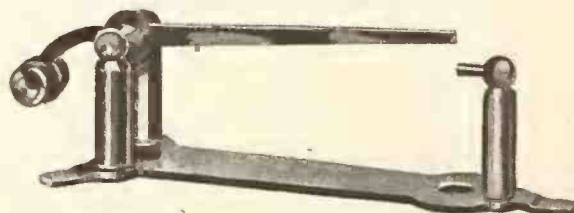

Use the Lakeside Rotometer and Know

Full Size, Gun Metal Finish—A device for testing the speed of your turn-table is as indispensable on your phonograph as the speedometer on your automobile.

Every Owner of a Phonograph Should Own One. Retail Price \$1.25, write for discounts.

LAKESIDE SUPPLY COMPANY,

339 So. Wabash Ave., Chicago, Ill.
Phone: Harrison 3840



It's three O' clock in the morn - ing. We've danced the whole night thru.

THIS YEAR'S BIG WALTZ HIT IS

Three O'Clock in the Morning

That Entrancing Melody You Hear Everywhere

"You can't go wrong with any 'Feist' song"

HEAR IT NOW

FROM OUR CHICAGO HEADQUARTERS—(Continued from page 110)

fusion and wide variety of records, but they are so arranged as to bring out the most popular numbers and the latest hits, and in choice or variety of music they range from the latest dance jazz to the popular, classical and operatic numbers.

This store, located on State street, is one of the busiest commercial arteries in the world and throughout the day the Actuelle counter is thronged by thousands.

Lidseen Cutters Do Well

A little further along in these columns are penned some few words pertaining to fibre needles and the statement is made by a man in a position to know that 1922 proved to be a phenomenal fibre needle year. Now we come to another high-grade accessory which ties up very well with the fibre needle and we find the same story holds true. This is the Lidseen fibre needle cutter, the clever little instrument

which sharpens a fibre needle without removing it from the tone arm of the machine. We get the statement from E. W. Koon, sales and advertising manager of Lidseen, that purchasers of these fibre needle cutters kept this department very busy all year.

Wallace Takes on Accessories

The Wallace Institute, producer of the famous Wallace Reducing Record, has received through its national advertising campaign something like 300,000 inquiries in the last year or two. This vast list of names has been carefully worked each month through the mails. The names have also been carefully tabulated in such a manner that it is known exactly which ones have talking machines and a fair idea is also had of the possibility each name offers for accessories. The time has come, according to Walter Eckhart, sales manager of the Wallace Institute, to take advantage of this list of 300,

000 names and he has, therefore, set about to take on a comprehensive line of high-grade accessories. These names will be reached through Wallace dealers working in conjunction with the regular Wallace traveling forces, which already cover the entire United States, and if by chance there is a certain locality which is not covered by a Wallace dealer or a Wallace traveling representative there are persons residing in that territory who will receive, through the mail, propaganda. At present Mr. Eckhart is open for several high-grade accessories which he intends to add to his already large line and any manufacturer who has something of first-class value will do well to get in touch with Mr. Eckhart at the Wallace Institute sales offices in this city.

Fibre Needle Manager Happy

H. J. Fiddelke, sales manager of the Hall
(Continued on page 112)



Style J

KIMBALL PHONOGRAPHS

The Greatest Phonograph Value

The dealer who sells the Kimball will not only have ready sales but satisfied customers and is building future business. Compare the Kimball in Construction or visible beauty, or in TONE or accurate reproduction and there is none to excel. Exclusive features appeal to buyers.

Console and Upright Types;
Variety of designs;
Wide range of prices;
Reliable guarantee.

Ask about Territory and Agency Terms.

W. W. KIMBALL CO.
Established 1857

Kimball Hall 306 So. Wabash Avenue CHICAGO
Manufacturers of Phonographs, Pianos, Player Pianos, Pipe Organs, Distributors of Okeh Records.

Kimball Phonographs Play ALL Records



Console Model Style S

Excel Phonograph Mfg. Co.
400-412 W. Erie Street
CHICAGO



Style 70
Capacity 100 Records

Cut on left shows filing system built in beautiful cabinet finished in Mahogany, Fumed or Golden Oak. Files your records horizontally and prevents warping.

Circular and Prices on Request



Style 16
Carries 10 Records

Cut on right shows our 50 inch Phonograph equipment with Adams Improved record filing system made in five sizes. Sold with or without filing system. Sold in Walnut, Mahogany, Fumed or Golden Oak finishes.



Style 5
Large 3-Spring Motor
Powerful Reproducer

FROM OUR CHICAGO HEADQUARTERS—(Continued from page 111)

Mfg. Co., reports that the year just passed was one of the biggest, if not the biggest, in the history of the Hall Mfg. Co. Nineteen hundred and twenty was a phenomenal year for fibre needles, according to Mr. Fiddelke, but he believes that when the final figures for 1922 are compared they will overshadow those of 1920. The prospects for the new year are very favorable and a survey of the trade indicates that high-grade dealers all over the country are devoting more attention to featuring the merits of fibre needles than ever before.

Cheney Activities

Professor Forest Cheney, of the Cheney Talking Machine Co., returned from an extended trip in the East where he called on the Cheney distributors and dealers in the States of Ohio, Pennsylvania, New York, New England and other points. The trip was made in the professor's famous "Blue Gull" Packard

car, which has already traveled thousands of miles in the interest of co-operation with Cheney distributors and dealers. Professor Cheney has made trips all over the country visiting Cheney agents, giving co-operation and working out campaigns by sales talks, banquets, etc.

Professor Cheney reports that a very large business was done in the East in the latter part of 1922 and the dealers are looking forward to a very good year in 1923. In fact, he says that they are emphatic in their statements concerning the decided change the present year will bring, and are making preparations accordingly.

The executive officers of the Cheney Talking Machine Co., at 24 North Wabash avenue, are equally happy over the prospects in the West and the future optimistic indications in the West for the coming year.

C. L. Noble, of the Cheney headquarters, says: "We consider the growth of business on the Pacific Coast to be really phenomenal. It goes to show that there is an unusual demand for high-grade phonographs in California. The people in the West are showing a fine sense of discrimination in the reception they have given the Cheney on the Pacific Coast, and we look for a splendid business in both the East and the West during the year which has opened so propitiously."

"The Munson-Raynor Corp., 643 South Olive street, Los Angeles, Cal., new Cheney distributor, has met with a great deal of success with the Cheney line since affiliating with us in the latter part of the Summer. It has placed the Cheney in some of the largest retail establishments on the Coast, including Bullock's, the leading department store in Los Angeles, Thearle's Music House of San Diego, the White



A Revelation in
SMOOTHNESS
and
QUIETNESS

The "OLD RELIABLE"
Over 1,000,000 KRASCO
Motors in Use Today.

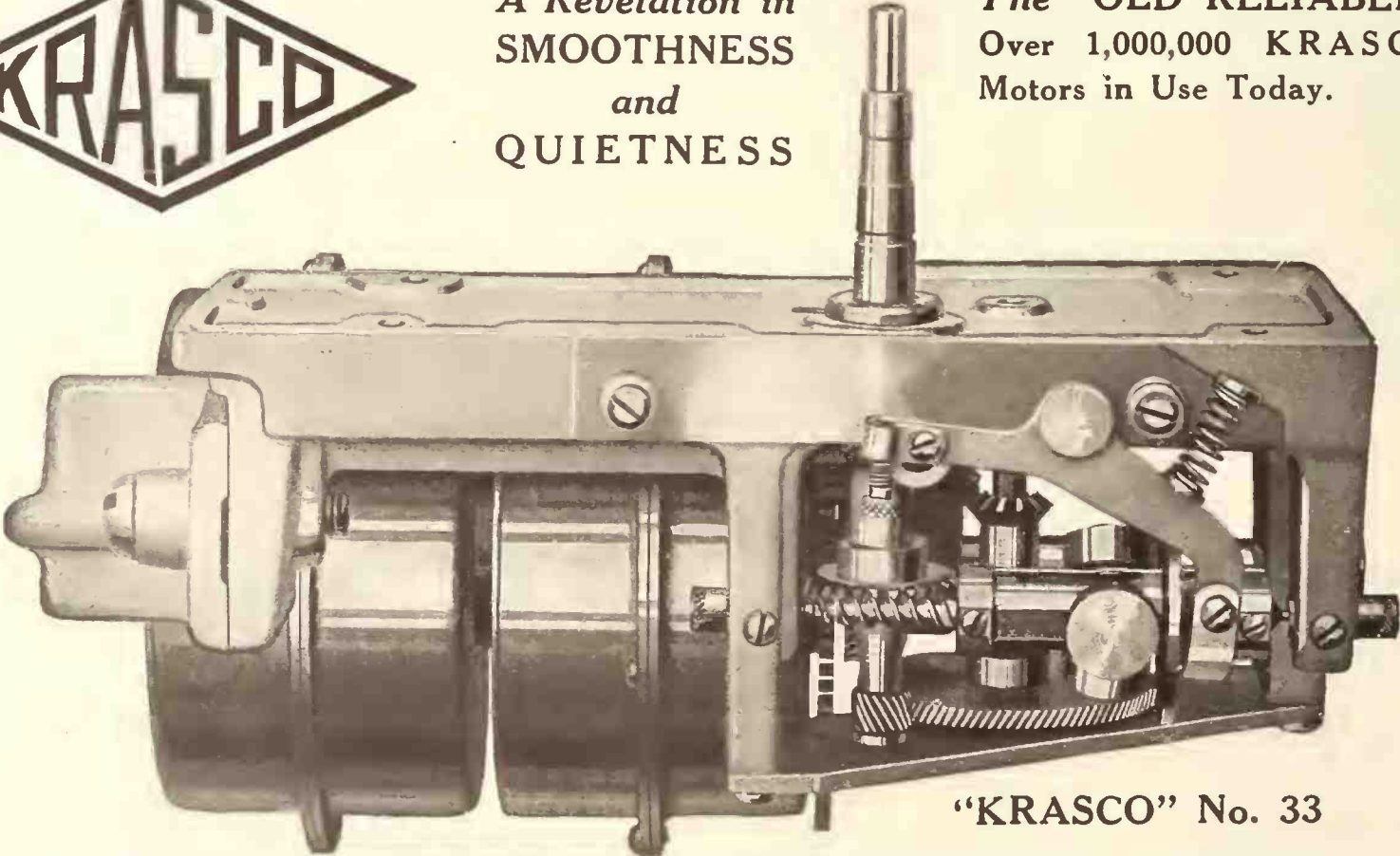

"KRASCO" No. 33

No matter what your motor requirements are KRASCO will fill the bill. If your trade wants reliable motors to play from four to ten ten-inch Records at one winding KRASCO will do it. Write for literature on KRASCO MOTORS. Types 2, 3, 4, 22, 33 and 41.

KRASCO MANUFACTURING COMPANY
451 East Ohio Street CHICAGO, ILL.
Eastern Branch, 120 West 42nd Street, New York

FROM OUR CHICAGO HEADQUARTERS—(Continued from page 112)

House in San Francisco, and many other leading music stores."

Graphite Facts From Joyce

M. B. Joyce, vice-president of the Superior Flake Graphite Co., has received a communication from the company's mines, located in Ashland, Ala., stating that the deposits continue to be worked to the fullest capacity. The concern markets a high-grade flake and amorphous graphite as well as a full line of talking machine grease and other graphite lubricants of high quality. According to Mr. Joyce, there is a great deal of difference between the needle graphite and the synthetic, in that the synthetic graphite is quite undependable because of certain physical peculiarities which cause it to become hard or packed, whereas the needle graphite, when absolutely pure and free of foreign elements, always maintains perfectly smooth surfaces which never become hardened in spots. Mr. Joyce has a very interesting exhibit of all types of graphite, including a series of large glass vials which contain samples of the raw, freshly mined ores, as well as specimens showing each stage through which the graphite goes until the finished article is produced. This exhibit is located in the Chicago office, and visitors to the Superior Flake Graphite Co.'s headquarters are always assured of a liberal education concerning graphite when they call on Mr. Joyce.

Great Furniture Shows Under Way

The important furniture shows of the year have officially opened in both Grand Rapids and Chicago and furniture dealers from all parts of the country are visiting these two shows. Considerable interest is being manifested by the dealers in the possibilities of developing talking machine business during the coming year, and the various talking machine exhibits at the shows, particularly in Grand Rapids, attracted a great deal more attention than in recent years.

It is quite likely that during 1923 a number of furniture manufacturers will either make cabinets for the talking machine industry or sponsor phonographs under their own names. While it is true that furniture business has kept up remarkably well during the past year the possibilities for developing talking machine business are being carefully considered by furniture manufacturers.

New Radio Simplifier Heard of

F. D. Pearne, chief instructor of the department of electricity, Lane Technical High School, who writes radio news for the Chicago Herald and Examiner, featured a story recently pertaining to a new type of radio receiver made by Norman S. Richmond, of Chicago. This new receiver, according to the item, is the result of an accidental discovery. As the story goes, Mr. Richmond was experimenting with a method of telephoning over live electrical wires and was suddenly surprised by picking up a radio concert from Station KYW, Chicago. As worked out from this discovery Mr. Richmond's new device picks up radio waves merely by being hooked up to an electric light wire. In the new instrument no paneling is used, for there are absolutely no adjustments, knobs or dials of any kind. All that is necessary is simply to turn on the current and the music comes in. There are no batteries, no detector, no variable condensers and no transformers.

Mr. Richmond is one of the old-timers in the music game in Chicago and at various times has conducted retail music establishments in the States of Wisconsin and Illinois. He has not only been selling pianos, but talking machines as well, and is well known throughout the Western trade.

Selling Music to the Chinese

Fred Firestone, manager of the Schumann Piano Co., Victor dealer, of Rockford, Ill., and one of the best-known music men in the Middle West, dropped into the Chicago office of The Talking Machine World the other day and told the following interesting incident:

"One day about noon, several weeks ago, I

was walking down the street in Rockford. I had been out to see a prospect and was on my way back to the store and was feeling the pangs of hunger. I was also tired because I had had to walk over a mile and at the same time I was carrying a Victor portable. Therefore, I decided to stop long enough to have a bite to eat and at the same time rest my weary bones. I stepped into a Chop Suey joint, gave my order, and while waiting for my meal I started the portable. The record I first played was 'Three o'Clock in the Morning.' Soon the waiter came and I asked him what he thought of it. Being a Chinaman he didn't like it, but I thought I could make him like it. After the meal I checked the portable in the cloak room, chased back to the store and got an arm full of Chinese Victor records. I went back, got the portable, started a Chinese record, and soon had all the chefs and waiters gathered about me. Needless to say, I didn't have to carry the portable back to the store. I sold it then and there. I also sold the records and got every

think in the joint for a prospect. In a little less than two months I have been rewarded with over \$350 worth of portable business, the records alone averaging something like \$60 per month."

The above was Fred's interesting story and in conclusion he remarked that he wished he was in a position to take a crack at the hundred and twenty thousand Chinese residing in Chicago.

Opening of New Rainbo Gardens

The opening of the new Rainbo Gardens in this city recently was one of the gala events of the season, being attended by 4,000 people, with 5,000 other dance enthusiasts being unable to obtain admission. Columbia artists predominated in the entertainment, one of the stars of the evening being Dolly Kay, exclusive Columbia artist and well known on the vaudeville stage.

Frank Westphal, another exclusive Columbia artist, received the biggest reception of the eve-

(Continued on page 114)

BEAU BRUMMEL In Squeaky Shoes!!

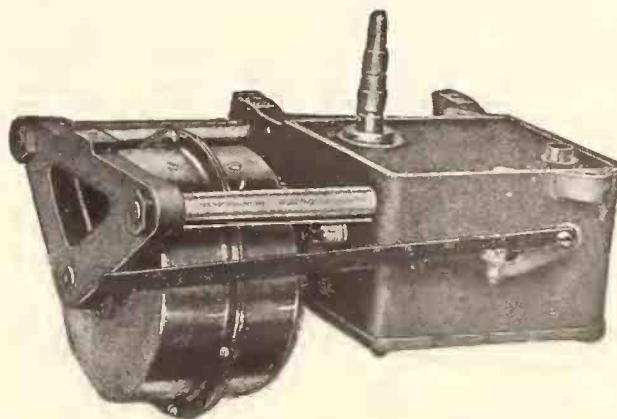

AN EXQUISITE CABINET WITH A CRUDE MOTOR

A thing may be durable and yet most objectionable.

Not so long ago, all motors were noisy. The coffee-mill-like winding sounds and the mechanical sounds of the motor were the accustomed though annoying prelude to an operatic air.

Today, instruments equipped with our enclosed, automatically lubricated motors avoid this objectionable defect. Not a sound—No intrusion of mechanics into the artist's offering, they are musical instruments—not machines.

Also, manufacturers were accustomed to bear a certain amount of bother and expense due to motor troubles after their instruments were sold.

Most of the makers of fine Phonographs now use our equipment, their motor troubles are forgotten, their costs as well as their overhead expense are reduced, and their cabinet work, no matter how exquisite, is matched in refinement and quality by the mechanism inside.

Let us send samples for trial at our expense to your Mechanical Department. See for yourself just what we offer at less money than you are doubtless now paying.

Let Us Furnish You Samples

United Manufacturing and Distributing Company
536 Lake Shore Drive CHICAGO

FROM OUR CHICAGO HEADQUARTERS—(Continued from page 113)

ning when at about 1:30 the crowds on the dance floor refused to leave when he finished playing and gave him an ovation lasting five minutes. Frank Westphal and his orchestra play nightly at the Rainbo Gardens and Columbia dealers are taking full advantage of this important assignment.

W. H. Huth Reviews Year's Activities

W. H. Huth, president of the Walbert Mfg. Co., has the following to say concerning the past year's activities:

"Nineteen twenty-two has been a very satisfactory year, particularly the closing months of the year, which turned into a whirlwind finish which swamped practically everybody making good merchandise. This showed that the public not only has regained buying power but is supplying it intelligently. We believe that a careful investigation of the stocks on hand to-day will reveal that the surplus of inferior stock is pretty well worked off and that dealers are now in a position to take on other goods of quality,

which are obviously what the public now wants.

"From every point of view the phonograph industry appears to be on a solid basis and all

developments will be forward to better business and better profits. Determined and intelligent sales efforts during 1923 will win."

NEW VOCALION DISTRIBUTOR IN CHICAGO TERRITORY

Vocalion Co. of Chicago, Inc., Organized With Capital Stock of \$100,000 to Handle Exclusive Distribution of Vocalion Instruments and Red Records and Melodee Rolls

CHICAGO, ILL., January 4.—The latest talking machine distributing concern in the local trade is the Vocalion Co. of Chicago, Inc., organized recently to act as exclusive wholesaler in this territory for all Vocalion instruments, Vocalion Red Records and accessories, and Melodee music rolls, formerly handled by the Aeolian Co. direct through its own branch here.

The organization of the new company, which is headed by F. W. Clement, widely known in the local talking machine trade, is in line with the policy of the Aeolian Co. to supply its entire Vocalion, record and music roll trade

through a well-organized chain of distributors.

W. H. Alfring, manager of the wholesale department of the Aeolian Co.; O. W. Ray, man-



F. W. Clement

ager of the wholesale Vocalion Record department, and Frederick Sunderman, manager of the Melodee Music Co., were in Chicago last month to look after the details of transferring the distributing rights, the change becoming effective on December 18. Arrangements have been made whereby the entire personnel of the Aeolian Co.'s branch, with the exception of Harry Levy, the former manager, will serve the new distributing interests. Mr. Levy will remain in Chicago until February 1 and will then come to the Aeolian Co. headquarters in New York, where he will devote his attention to the distribution of Vocalion instruments.

The Vocalion Co. of Chicago, Inc., has been chartered with capital stock of \$100,000, the incorporators being Maurice Markowitz, Harry Flitzsten and D. Harold Davis. The headquarters of the company will remain at 529 South Wabash avenue, adjacent to the Loop.

It is stated that elaborate plans are under way for a strong campaign throughout the Chicago territory in the interests of the Vocalion line and the Melodee rolls. The Vocalion instruments and Red Records are already well represented among the dealers in this city and environs and not only will new dealers be established but a campaign of sales helps and advertising will be inaugurated.

NEW MUSIC HOUSE IN MUSCATINE

MUSCATINE, IA., January 2.—The Muscatine Music House has been opened at 210 Iowa avenue, this city, under the management of W. J. Burnett, who was formerly connected with the Schmidt Music Co. in this city. Miss Mabel Appel, who will be associated with Mr. Burnett, is also a former member of the Schmidt Co.

CHANGE IN WASHINGTON HOUSE

WASHINGTON, D. C., January 3.—The well-known music house of Sanderson & Speake, of 922 New York avenue, N. W., this city, has dissolved partnership. The firm will be known in the future as Speake & Spiggle.

Among the new incorporations in the State of New York is that of the Erasmus Music Shop, Brooklyn, capitalized at \$15,000. The incorporators are F. Boscia and A. J. Armour.

A Letter to the Trade

from the

Blood Tone Arm Co.

Just a brief outline of the policy which we shall follow during 1923.

The year just past has emphasized two facts, namely, that the phonograph trade demands the best possible tone arms at the smallest price consistent with a reasonable profit. The success of the "Blood" standard arm has proved this. We will, therefore, continue to furnish this arm at the same price as before. In addition, however, we will introduce new features as circumstances warrant, even to the extent of fur-

nishing *exclusive* designs to manufacturers whose outputs are large enough to warrant our doing so.

We wish also to impress on the manufacturer the importance of building tone chambers to conform to the dimensions of the arms used. The Blood Tone Arm Co. has an expert knowledge of the principles governing this part of your phonograph, which is *free* to all who use Blood arms.

Start the year right by starting with us.

All repairs and replacements *free*.

BLOOD TONE ARM CO.

326 River St.

:

:

:

Chicago

ROSA PONSELLE IN CLEVELAND

Famous Operatic Soprano and Exclusive Columbia Artist Appears at Public Auditorium—Concert Received Enthusiastically

CLEVELAND, O., January 6.—Miss Rosa Ponselle, famous soprano of the Metropolitan Opera Co. and exclusive Columbia artist, appeared recently at the Public Auditorium. Three hundred orphans, invited to attend the concert through the courtesy of the local branch of the Colum-



Rosa Ponselle in Concert

bia Graphophone Co., thoroughly enjoyed the program. Miss Ponselle favored her audience with several of the numbers that have contributed to her international fame, and an article from the Cleveland News the following day over the signature of Archie Bell, one of the country's leading dramatic critics, stated that Miss Ponselle had made the biggest hit of the season.

SONORA FOR FAMOUS CATHEDRAL

Mrs. E. J. Brewster, manager of the Sonora salons on Fifth avenue, New York, reported recently the sale of a Gothic Normandy Sonora period model to St. Patrick's Cathedral, just across the street from the Sonora establishment. The instrument will be used for recreation purposes by the officiating priests and also for special occasions. An interesting feature of the sale is the fact that the design of the Gothic Normandy Sonora harmonizes exactly with the architecture of the Cathedral.

UNIQUE CHRISTMAS GREETINGS

M. M. Blackman Sends Friends Original Christmas Card—Embodies True Christmas Spirit

KANSAS CITY, Mo., January 5.—The Christmas cards and Christmas greetings forwarded by various members of the local trade this season were exceptionally artistic and many of them decidedly original. However, one of the most unusual Christmas greetings that have ever been penned by a member of the local trade was the letter sent out by M. M. Blackman, of the Phonograph Co., of Kansas City, to his many friends. This letter, which embodies the true Christmas spirit, reads as follows:

"It seems to be a popular idea that after certain angels appeared in the sky 1,923 years ago singing 'Peace on Earth, Good Will to Men,' this peace just naturally came down to us like an estate from a rich relative.

"But as far as I have been able to observe, 'Peace among men' is something that is never given. It has to be achieved by each man, woman and child in each generation and this peace comes only through understanding—understanding the other fellow—about the biggest undertaking any individual can ever set for himself.

"So, in carrying on the work of this world—helping each other to live and be happy (which is 'Business')—Christmas comes with a challenge to 'Understand.'

"Can there be any task more worthy of effort and sacrifice than to 'Understand' and to make ourselves 'Understood'?

"Could there be any greater accomplishment than to 'Understand'?

"Is not this the supreme challenge of Christmas to our intelligence and to our conscience?

"To 'Understand' is my Christmas thought to you."

The Plaza Music Co., of Brooklyn, has increased its capital from \$10,000 to \$30,000 so as to handle its growing business.

ILSLEY'S GRAPHITE PHONO SPRING LUBRICANT

Ilsley's Lubricant makes the Motor make good is prepared in the proper consistency, will not run out, dry up, or become sticky or rancid. Remains in its original form indefinitely.

Put up in 1, 5, 10, 25 and 50-pound cans for dealers This lubricant is also put up in 4-ounce cans to retail at 25 cents each under the trade name of

EUREKA NOISELESS TALKING MACHINE LUBRICANT

Write for special proposition to jobbers ILSLEY-DOUBLEDAY & CO., 229-231 Front St., New York

WINDOW WINS HONORABLE MENTION

Will Feature Most Striking Sonora Window Displays in House Organ

Beginning with the current issue of the Sonora Bell it is planned to feature each month in this house organ of the Sonora Phonograph Co. the most striking window display received by the publication. The window il-

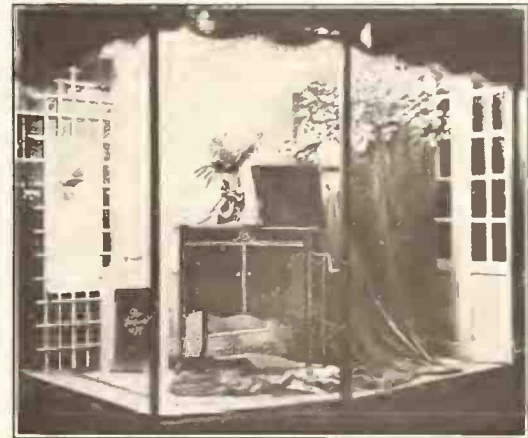

Sonora Window Wins High Praise

lustrated herewith, which was prepared by the Wittstein Music Shop, New Haven, Conn., was selected as the most striking window for the January issue. Mr. Wittstein has earned an enviable reputation in the window display realm and his windows almost invariably not only attract attention, but produce sales.

*A Triumph in Tonal Beauty—
Visible Charm and Adaptability*
The EMERSON Louis XV

THIS LOUIS XV is the crowning achievement of the Emerson line. A bigger attraction to the public—offered at a price that fairly compels sales. Like all Emerson phonographs The Emerson Tone—clear, true, full—does absolute justice to the record. The patented round music master horn carries and amplifies tonal beauty just as does the spruce resonator of the famous old "Strads."

From the standpoint of furniture the working out of the console idea, is especially adaptable because only the centre of the top is raised. Console lights on either side need not be moved while playing. Emerson line offers a machine to suit every taste and pocket book.

*Quality for Quality Our Price is Lower
Price for Price Our Quality is Higher*

Emerson value—backed by years of Emerson Advertising, makes The Emerson line—a sales bringing prestige creator for Progressive Merchants.

Write for details of our special franchise

WASMUTH-GOODRICH COMPANY, Peru, Indiana
MANUFACTURERS OF EMERSON PHONOGRAPHS



Emerson Louis XV Model

NOW is the TIME

Start your best year right by installing the best equipment. Van Veen booths, counters, record racks and musical merchandise selling equipment are built to meet a standard of quality.

Don't make the mistake of fitting up with unserviceable short-lived fixtures, whose only merit is a flashy

price. Such equipment at best is of only temporary use and must make way for Van Veen quality, sooner or later.

Why not install Van Veen equipment at once? Its moderate price will please you.

Mail us your requirements. Will send catalogue and quotation.

VAN VEEN & COMPANY, Inc., 413-417 E. 109th St., New York City

Phone: 7758 Harlem

Offices and Warerooms

B A L T I M O R E

Best Holiday Business on Record—Local Columbia Plant Starts Operations—New Store of L. & K. Snyder—Other News of Month

BALTIMORE, Md., January 12.—Christmas business in talking machines in Baltimore and vicinity was the best that the trade has known since the peak of war-time prosperity of a few years ago. This report is general from practically every musical store and talking machine shop in Baltimore and increases over Christmas of 1921 range from 20 per cent to as high as 120 per cent in one instance. While jobbing houses have not as yet balanced their books for the year every house reports an increase in business over 1921. That this increase is not greater is due to the fact of the jobbers being unable to get the popular lines of machines delivered in time for the holiday trade.

The record business for the past year was one of the greatest in history, the increase in

sales averaging as high as 50 per cent over 1921 in the case of E. F. Droop & Sons, Victor jobbers, according to Manager Roberts, who is very enthusiastic over the showing made last year and predicts an equally good year for 1923.

The Baltimore plant of the Columbia Graphophone Co. has started working again, employing several hundred men in the factory.

The new process Columbia records are making a big hit, according to Manager Parks, who reports being unable to supply the demand for all the popular dance records. The educational records have also taken a big jump in sales, due in a large part to the work of Miss Margaret R. Martin, who has spent considerable time in the Baltimore district and has just returned from a trip to Washington, where she appeared

before the Federation of Women's Clubs and also before the Department of Education, as well as a number of colleges and other institutions in Virginia, West Virginia and North Carolina.

The Brunswick agency here, through Manager Shaw, also reports a large increase over the previous year's business and the Caulfield Co., distributor of the Edison machine, reports one of the most prosperous years in the history of the firm.

Manager W. B. Turlington, of Sanders & Stayman, the Vocalion distributors, also reports big increases in sales over 1921. This concern is one of the pioneers among the music houses in the radio field and has opened a broadcasting station where it broadcasts concerts several times a week.

One of the handsomest music shops in Baltimore is that which has recently been opened by L. & K. Snyder, of East Baltimore. It is located on East Monument street.

R. H. Fox, of Lexington, Va., reports the sale of sixteen Grafonolas and hundreds of educational records to schools in the vicinity during the past six months.

The Rosenstein Piano Co. has had excellent results from a salesman contest which the firm has been conducting for the last six months and in which prizes were offered to the salesman making the best showing. This contest has been the means, according to Manager George P. West, of bringing in more business in a stated time than ever before in the history of the firm. Amberg & Jordan also report good results from the outside sales force which has been working the talking machine business in the past few months.

Cohen & Hughes and Eisenbrandt's, the other Victor jobbers in this city, also report very substantial business during the past year and predict a steady increase for 1923. In fact, they found it difficult to supply enough Victor machines and records.

J. N. BLACKMAN ON WEST INDIES TRIP

J. Newcomb Blackman, president of the Blackman Talking Machine Co., New York, Victor wholesaler, accompanied by Mrs. Blackman, will sail to-day (January 15) on the S. S. "Megantic" of the White Star Line for a twenty-eight days' trip. A very interesting program has been prepared for this journey and among the points to be visited are the following: Havana, Santiago, Kingston, Jamaica; Colon, Panama; a trip through the Canal, Caracas, Venezuela; Port of Spain, Barbados, Martinique, St. Thomas, San Juan and the Bahamas.

"We Serve the South"

OKeh
The Record of Quality

For the coming year

You can rely upon us to maintain the same unflinching promptness and efficiency that has been so characteristic of our service in the past. Whatever your needs may be for

OKeh Records

do not hesitate to call on us. Our stock of records is kept complete at all times and your orders will be given our immediate attention.

Wholesale Phonograph Division

J. K. POLK FURNITURE CO., Inc.

Offices and Show Rooms:

294 Decatur Street

ATLANTA, GA.

Inquiries
from
Dealers
Solicited

TOLEDO

Close Successful Year—Stocks Low—Ignaz Fischer Moves—Paul S. Clough With J. W. Greene Co.

TOLEDO, O., January 4.—Holiday trade was very good here. Dealers for that reason experienced difficulty in keeping machine stocks complete. Record sales never have achieved such large totals.

At the Toledo Talking Machine Co. the year just closed was a successful one. The demand for machines towards the end of the season was such that the supply did not go around, Chas. H. Womeldorff states. The new year's outlook is very promising. With the situation abroad once adjusted and with export demand again in evidence, trade will go ahead very rapidly, he believes.

Talking machine stocks in the hands of dealers are not large. Therefore, merchants will be in the market and buying in a nominal way throughout the year.

At the Lion Store Victrola rooms the holiday volume was the largest in the history of the store. Business closed put the year ahead of the preceding one, A. J. Pete states. A significant fact in connection with this was that patrons were very discriminating. They wanted to buy, and did buy in large numbers; but it was necessary to convince them that they were receiving their full money's worth. This is a healthy sign, for it means folks have come to realize the value of quality merchandise.

The Ignaz Fischer Music House has moved from Madison avenue to the new store at 707 Adams street. This location is in the newer shopping section and within a stone's throw of five other music houses. Holiday trade in Brunswicks was gratifying and gives promise of a prosperous new year, it is said. Hyman Rothenstein is the new proprietor of the store. Miss Hilda Heath has joined the store force. She will specialize in records and sheet music.

The J. W. Greene Co., according to E. A. Kopf, not alone did the largest Christmas business in the history of the store, but likewise sold all instruments which were intended to be used as January specials.

The new year has started well. The Brunswick York console model is in great favor with patrons, as is also the Tudor model. This line, in connection with the Victrola and Cheney, gives the house a very strong representation. Remodeling plans are under way. It is hoped to complete this program before the middle of May, at which time a concert and large reception are planned.

Paul S. Clough is a recent addition to the talking machine sales force of the J. W. Greene Co.

At the Goosman Piano Co. Christmas trade recorded a very satisfactory total. The Columbia, Vocalion, Starr, Bush & Lane and Granby talking machines are dealt in. Miss Grace M. Greeman is in charge.

New Year plans included an aggressive newspaper and sales campaign. Women will be employed to do house-to-house canvassing, for it is found that, as a rule, they are better able to secure access to the home.

Fred. N. Goosman, president of the company, has been confined to his home for the past ten days on account of illness.

The Kneisel Music Co., primarily a sheet music and small goods dealer, will add records to its stock. In order to give the new line the proper start the store will be rearranged. Record files will be placed opposite the sheet music counters, close to the front of the store, and music rolls will be placed on racks nearby.

John F. Kneisel believes these three items should make a strong combination and will be worked together. When a customer buys sheet music she will be asked, "Have you a phonograph or player-piano?" and told that the selec-

tion just purchased may be had in either a record or music roll.

A direct advertising campaign will be employed in connection with the newspapers to acquaint people with the records carried.

At the LaSalle & Koch Co., Victrola Shop, the December volume reached a 20 per cent increase. Machine sales were very good and record demand was phenomenal, R. O. Danforth states. Since Christmas a few machines have been exchanged for larger ones, which seems to indicate that patrons were sold the instrument they desired but have since either enlarged their desires or have been influenced by the salesman's arguments used at the time of the sale. Miss Mildred Christman, an experienced record saleslady, has joined the department force.

The J. W. Greene Co. is featuring the Zenith radio set, according to W. W. Baillie. This outfit is sold upon the instalment plan and therefore must give satisfaction. Demonstrations are given in the home to live prospects and recent sales are encouraging.

OPENS CANADIAN BRANCH

Plaza Music Co., New York City, Opens Toronto, Ont., Branch to Facilitate Service

The Plaza Music Co., of New York City, has completed arrangements for the opening of a Canadian branch of its business in Toronto, Ont., which will be under the supervision of M. G. Beatty, who is widely known in the talking machine field of Canada. The branch was opened with the idea of giving direct and uninterrupted service to the company's growing business in Canada. The new branch will function as a complete supply house unit, carrying a large stock of needles, albums, repeaters, motors, tone arms, etc., for practically every make of motor and equipment. Main springs and all other minor parts will also be carried in stock.

IMPORTANT NEW BILL IN OHIO

Measure Designed to Amend Present Conditional Sales Act Extends Filing Period for Chattel Mortgages—Penalties for Fraud

CLEVELAND, O., January 6.—Charles H. Yahrting, of Youngstown, chairman of the Legislative Committee of the Music Merchants' Association of Ohio, has urged all members of that Association to bring pressure to bear on all Senators and Assemblymen in the State with a view to having passed a new bill amending existing laws covering the filing of chattel mortgages and the status of conditional sales contracts.

The feature of the amendment that makes a special appeal to piano men and which has been advocated for a long time is that providing that mortgages may be filed within ten days of their making instead of at once, as provided for in the existing law. Piano men, as well as other merchants selling on instalments, have had considerable trouble under the present law through having chattel mortgages declared void because they had not been filed the same day as executed. It was found that there were plenty of purchasers who were familiar with the law and ready to take advantage of it.

The amendment to the Conditional Sales Law provides for the indexing of chattel mortgages by the names of the parties to them, and makes it illegal to give a false name or address in such mortgages and provides a penalty of from one to three years in prison where the sum involved is over \$35 and small fines and prison sentences when the amount involved is less.

The Legislative Committee of the Ohio Association has been very active for several years and has already accomplished much good in investigating or supporting legislation calculated to protect music merchants and others in instalment sales. A year or two ago the Association was instrumental in having passed a law making it a crime if goods being paid for under instalment contract were moved to other States.

KEEP YOUR NAME BEFORE YOUR CUSTOMERS



Your name imprinted on Simplex and K-E Record Cleaners at no additional cost. A really efficient cleaner and a good way to advertise your business.

Ask us to submit designs.

K-E AUTOMATIC STOPS

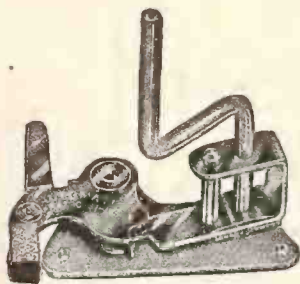

The K-E is still the best Automatic Stop made Because it:
 Avoids motor strain
 Is not attached to Tone Arm
 Low installation cost
 No extra parts
 Operates all Records.

Send 50c. for sample

Kirkman Engineering Corporation
 484-490 BROOME ST. NEW YORK

TRADE EQUALS EXPECTATIONS IN BROOKLYN

Holiday Sales Totals in Most Cases Larger Than for Same Period Last Year—Wholesalers Aid Dealers—Record Sonora Sales—Presents Staff With Christmas Gift of Salary Increase—Nostrand Shop Enlarged—Albert Bersin Opens Branch—Other Happenings

The large majority of dealers in Brooklyn and Long Island are very much satisfied with the volume of business done during the past Christmas season, as it is reported that sales compared favorably with those of last year for the same period. In most cases sales totals were larger than last year, and very few dealers report a decrease, especially in the sales of instruments. Demand for records has not come quite up to expectations. An interesting condition this year was the fact that the demand for instruments, though larger than last year, was confined to the lower price models, or those models which sell around \$100 to \$150, whereas last year the demand was for the higher price models. Also last year records were in much more active demand, so with this great difference in conditions, it is noteworthy that dealers in this territory were able to make such a splendid showing. In consequence of the large number of individuals who purchased instruments last year, it is only reasonable to expect that the future demand for records will be greater, and no doubt the first quarter of this year will be a busy one from the standpoint of record sales. Therefore, there is every reason to believe that the talking machine business generally promises to be a healthy and normal one in every way during 1923. A commendable feature of retail merchandising this past year in this territory was the large amount of preparation which has been going on for some time past; especially noticeable was the enlarging of showroom space and general rearranging of stores, the installation of the most improved fixtures, which no doubt materially assisted in obtaining a splendid holiday business. One dealer, who has just completed extensive alterations to his store which gave him a much larger floor space, stated with great enthusiasm that his holiday business in 1922 more than tripled that of the previous year.

Wholesalers Co-operate With Dealers

Wholesalers kept their staffs busy during the

holidays by offering to dealers the utmost co-operation, making deliveries of records and machines up to the last minute. The last day before Christmas found a number of sales representatives hard at work helping out dealers in taking care of the frenzied crowd of buyers, which had waited until the last minute to make purchases. This co-operation reflects the splendid work that wholesalers are doing in this territory and it is keenly appreciated by dealers who benefited greatly from it.

To sum up, it is the consensus of opinion among talking machine men here that everyone has enjoyed a prosperous year in sales. The past twelve months has been one of complete reorganization, and those dealers who have heeded the sign of the times and have employed the proper methods for securing business, namely, of closely following up every prospective purchaser intensively, have been amply re-

warded with a very satisfactory volume of business.

The new year, from all indications, promises to be a more normal one in business generally, and the talking machine trade, by virtue of the experience gained in the past year of highly concentrated selling, is well prepared to get its share of the expected upward trend in buying.

Record Sonora Holiday Trade

The Long Island Phonograph Co., Sonora wholesaler for this section of Metropolitan New York, reports that Sonora dealers enjoyed the largest holiday business in years, limited only by their ability to secure enough of the popular price models, such as the Marquette, which retails for \$100. Officials of the company made strenuous efforts to supply the demand for Christmas, but were unable to secure sufficient instruments to meet the needs of dealers. R. H. Keith, general manager of the company, is very much pleased at the business done, and was confident that Sonora dealers got their share of the business. He stated that sales of Sonoras in this territory for the entire year show a large gain over last year.

J. J. Schratweiser, sales manager, was kept extremely busy during the rush dispatching machines to dealers on hurry calls, and through his co-operation many dealers were able to close sales which they might otherwise have lost. The entire sales staff was put at the disposal of dealers, a service which was keenly appreciated, and no doubt helped materially in obtaining the splendid results reported. As a mark of appreciation for the hearty co-operation given him by the office staff during the year Mr. Schratweiser gave them a luncheon party at a nearby cafe which was thoroughly enjoyed by everyone.

Christmas Gift of Salary Increase to Staff

C. H. Keith, president, in accordance with plans worked out some time ago, presented each member of the organization with a Christmas gift in the shape of a substantial increase in salary. This fine gift was in addition to an individual one which Mr. Keith gave personally. "The spirit of co-operation in our organization," stated Mr. Keith, "is ample evidence why the Long Island Phonograph Co. has made such rapid strides in its growth and we look forward to new year developments with the greatest confidence and with an organization prepared to meet all emergencies."

Nostrand Music Shop Enlarged

The Nostrand Music Shop, 768 Nostrand avenue, recently completed extensive alterations

VICTOR
RECORDS

1923

It was foresight and not fortune that made it possible for the Victor retailer to serve his trade so well during 1922.

The same attention to the retailer's needs—the anticipation of the trend of the public's purchasing power and inclination—will be paramount with us during 1923.

VICTOR
RECORDS

G. T. WILLIAMS CO. Inc.

272 Flatbush Avenue Extension
Brooklyn, N. Y.



THE INSTRUMENT OF QUALITY

Sonora

CLEAR AS A BELL





THE more experience you have as a Phonograph Dealer the more you will appreciate the service we are prepared to render as Distributors of Sonora Phonographs in this territory.

We invite correspondence or calls from Dealers who have come to recognize the distinct value of the Sonora line.

Why not find out for yourself what Sonora is doing for other Dealers under conditions more or less like your own?

Any communication from you will have our prompt and careful attention.

LONG ISLAND PHONOGRAPH CO. INC.

150 Montague Street, Brooklyn



I get so blue thru and thru when the leaves come a tum - ble - ing down from the trees!

The Big Boston Fox Trot Hit

When The Leaves Come Tumbling Down

HEAR IT NOW!



to the store, more than doubling the original floor space. Theodore Lohr and A. Heizie, the proprietors of this thriving business, recently purchased the entire building at this address, and plans were then made to take over the adjoining space in the rear of their present showrooms, making one large ware room. The work was started some time ago, and it was rushed to completion just in time to take care of the holiday trade. The entire store has been completely equipped with the most modern fixtures, including a large number of private hearing rooms, new record counters and record racks, all of which makes this store one of the best arranged in Brooklyn. A large and well-arranged display space has been laid out in the auditorium, where every model of Victrola is shown to advantage. The store features the Victor line exclusively. Business during the holidays was excellent, which, Mr. Lohr stated, put over the top the sales total for the year, making 1922 the greatest year in their history.

To Help Dealers Take Inventory

Now that the holiday rush is over the American Talking Machine Co., popular Victor wholesaler for Brooklyn and Long Island, is preparing to assist dealers in the annual taking of inventories. This work is of the greatest importance, and it requires a large amount of detail, which must be done with absolute thoroughness, in order that dealers can know to the last record and package of needles how much actual business has been done and with what profit. R. H. Morris, general manager of the company, reports one of the largest holiday demands ever experienced, especially in machines, while the record demand, which was a bit slower, has shown an encouraging spurt during the past ten days that is bound to make up for any deficit in this phase of the holiday business.

Herman Rushin, who has charge of the record stock for this wholesaler, was unfortunately stricken with an attack of appendicitis, during Christmas week, and had to be rushed to the Post Graduate Hospital, where he was immediately operated on. Mr. Rushin is an ex-service man, extremely well liked by his fellow workers, who visited him in a body on Christmas day to cheer him on to a speedy recovery.

"Maderite" Covers Grow in Favor

A. Bruns & Co., manufacturers of "Maderite" covers for talking machine delivery, report that the output of their covers to the talking machine trade for the past year was the greatest in the history of the company. "The distribution of our covers," stated officials of the company, "has now reached every State in the country, and also a number of foreign countries. Plans are now being prepared for the new year that it is expected will more than double the output facilities to meet what we believe will be one of the most prosperous years in the industry."

Albert Bersin Opens Branch Store

Albert Bersin, who conducts a large talking machine business at 1248 Fulton street, opened

another new store to the public this month at Bedford avenue near Fulton street, which is the last word in modern retail store arrangement. Mr. Bersin heretofore has devoted his entire energy to the merchandising of the Brunswick and Sonora lines at his Fulton street store, but with the opening of this new store, where the Victor line is handled exclusively, he is fulfilling a long-cherished ambition to retail Victor merchandise. Mr. Bersin has been highly successful in the retail talking machine field and is well able to conduct this additional business in a successful manner. The new store is equipped throughout with every modern convenience and has a large floor space. Record racks, sound-proof booths and display cases have been installed, while the main auditorium is attractively arranged as a large display room for the showing of Victrola models. A large show window, which is perhaps one of the most attractive in Brooklyn, has been constructed in front of the store.

Ideal Music Shop Secures Sonora Line

During the rush of an unprecedented demand for Sonora machines during the month of December, the Long Island Phonograph Co.,

Sonora jobber in this territory, granted a franchise to the Ideal Music Shop, at Central avenue and Hart street. The Sonora will be handled exclusively. Marco Maggio, the proprietor of this new shop, for some time has been negotiating with officials of the Long Island Phonograph Co. for a Sonora agency, with the result that a first shipment of machines was received by him in time for Christmas business. Lee Coupe, genial representative of the Long Island Phonograph Co., closed the deal.

Albert Steinhardt With Geo. Millard

Albert Steinhardt, who has been connected as salesman with Jacob Bros., 997 Broadway, popular Victor dealers, has resigned his position with this company to accept a like position with Geo. Millard, who recently opened one of the finest retail stores in all Brooklyn. Mr. Steinhardt is one of the younger members in the talking machine field, and so far has attained considerable success as a talking machine salesman. His genial personality has won for him many friends in the trade, and he is rapidly establishing for himself an enviable reputation that is bound to make him an extremely valuable man.

ANNUAL COLUMBIA NEW YEAR PARTY

Members of Executive Staff and Employees of the Columbia Organization Enjoy Annual Get-together in Company's Auditorium

The annual New Year's party given by the Columbia Graphophone Co. to the members of the executive staff and to all employees was held recently in the great auditorium on the twenty-fourth floor of the company's executive offices in New York City. The party started off with a luncheon at noon at which H. L. Willson, president of the company, delivered an address in which he thanked all members of the Columbia organization for the splendid work done during the past year, giving a brief résumé of the company's activities in which he emphasized the fact that every member of the Columbia organization played a most important part in bringing to a close a very successful year.

Geo. W. Hopkins, vice-president and sales manager, also addressed the gathering, as well as several other members of the executive staff.

Following the luncheon the floor was cleared for dancing, the music being furnished by exclusive Columbia record artists, who played during the afternoon until the party adjourned. A feature which was introduced during the dancing was the rendition of several selections by Columbia artists in between dances. Another feature which produced a lot of fun and general merriment among the gathering was a huge "grab-bag" which was placed in the center of the floor and from which every employe grabbed a gift or a present of some sort. During the grabbing of these gifts from the bag, several members of the organization were the cause of much laughter for the presents re-

ceived were of a funny character, but later the recipients of these joke packages were given others to replace them.

This party arranged by the officials of the company is looked forward to by every employe of the organization as it affords an opportunity to get together at one time the large personnel which comprises every branch of the Columbia organization. At this time officials and executives of the company take the opportunity to extend their personal congratulations and thanks for the splendid spirit of co-operation which has made the past year a highly successful one.



Phono-graphs

Reg. U. S. Pat. Off.

5 Upright
3 Console
1923 Models
of Standard
Value Always
Offering the
greatest oppor-
tunity to dealers

Also Radio Cabinets



COLUMBIA MANTEL CO.
175-177 Powers St. Brooklyn, N. Y.

Real Merit Wins—The "Recordion" has it



"Call Me Back, Pal o' Mine" and "Save the Last Waltz for Me" are all that transcendent waltzes can be. Both are given the last pinch of perfection by the Columbia Dance Orchestra and the faultless reproduction of the Columbia New Process Record. A-3752.

**Columbia Graphophone Co.
NEW YORK**

ATLANTA

*Many Plans for New Enterprises
—Developments of the Month in
Leading Southern Trade Centers*

ATLANTA, GA., January 8.—Optimism and the increased prosperity of this district are responsible for a number of plans for new enterprises which will probably result in additional talking machine dealers here in Atlanta. Details are not yet complete, but the next thirty or sixty days should show some interesting developments.

The holiday business was in the main quite satisfactory. All dealers report business as substantially ahead of last year's, the feature of the trade being the increased number of moderately priced outfits sold. This would indicate that the family of average means is again in a position to purchase something other than necessities, and, further, the larger number of machine sales insures a good record business during the coming months.

Most dealers in this territory had sufficient courage in the Fall to order a stock large enough to take care of their holiday requirements. There was no widespread shortage of product, although most dealers were completely

A NEW Repeating Device



A new Repeating Device. Wonderfully simple. Overcomes and eliminates objections to other repeaters. Will not mar or scratch the record. Made of metal—will last a lifetime. Adjustable for 10-inch or 12-inch records.

THE RAPID REPEATER

Repeats any record instantly—no breach between ending and starting, thus providing continuous music. Here is a sturdily built repeater that sells for almost the same price as celluloid or other flimsily made machines. Fully Guaranteed.

**RETAIL
PRICE \$2.00**

Send for sample and discounts. Agencies now being established. Write for our attractive proposition.

THE RAPID REPEATER CO.
266 Van Alst Avenue LONG ISLAND CITY, N. Y.

sold out of some few models, particularly on consoles priced between \$100 and \$200.

The Southern Sonora Co., which has been distributing Sonora machines throughout the Southeast from this city, has moved its general offices to Selma, Ala., but, we understand, will warehouse a stock here and continue to distribute from this point.

Immediately following Christmas the Cable Piano Co. conducted a largely advertised sale of its "trade-in" machines. These were thoroughly reconditioned, attractively priced and disposed of readily.

In a special interview M. E. Lyle, who represents the Strand interests throughout the entire Southeast, and who is as closely in touch with general conditions as anyone in the talking machine industry, reports that the outstanding feature of the year just ended has been the complete acceptance of the console model.

Mr. Lyle recalled other epoch-making years. The one marked by the change from the cylinder to the disc type, later the abandonment of the horn, which was supplanted by the hornless machine, then followed substitution of double-disc for the old single-faced record. Just so the universal demand for the flat-top console proves its superiority over other designs and marks the beginning of a new period in the field of talking machine progress.

Mr. Lyle predicts that the dealer who does not fully realize the importance of this change, and fails to meet the demand with a full line of popular-priced, flat-top period design consoles, will find business difficult to obtain.

W. C. Fuhri, of the General Phonograph Corp., New York, was in this city recently, spending several days with the J. K. Polk Co., Okeh distributor. Okeh dealers throughout the Southeast are enjoying a large trade on the Okeh hit, "Sugar Blues." This number was made by Sara Martin, a new addition to the Okeh catalog of records by famous race artists.

Chas. J. Rey, of the wholesale phonograph division of the J. K. Polk Furniture Co., is planning an extended trip of three or four weeks in Florida in the interest of the Okeh record, Honest Quaker main springs, repair parts, etc.

The Cochran Furniture Co., this city, has recently been added to the local list of Okeh dealers.

Phonographs, Inc., Edison jobber, finds its dealers universally enthusiastic over the value and the sales appeal of the London console. It retails at a price which brings the Edison, in flat-top, console design, within reach of the family of moderate income. Clarke & Jones, of Birmingham, have recently added both the Edison and Brunswick lines.

The local Brunswick branch has just received samples of the new Brunswick model console, "The Tudor," and the entire organization, also dealers that have seen this new model, are very much elated over it.

Ralph Hooke, Brunswick salesman, spent the holiday season at his former home in Cincinnati, O.

Ludden & Bates, local Brunswick dealers, reported a very satisfactory phonograph business for December and state it was the higher-priced Brunswicks which were most in demand. This firm had a very attractive window for the holidays—a Brunswick Japanese lacquer console occupying the center of the display.

M. B. Duke, who is looking after Brunswick interests in the State of Florida, spent the holidays in Atlanta. The happy smile and countenance of Mr. Duke certainly tell the story that he and Brunswick dealers in Florida enjoyed a real good holiday business.

Columbia dealers in Atlanta report that they enjoyed one of the largest Christmas trades in many years. Especially was this true of record sales.

H. J. Jenkins is now connected with the Cochran Furniture Co., Columbia dealer of this city, in the capacity of manager of the Grafonola department. Mr. Jenkins is well known throughout the South in the talking machine industry.

The Kenny Furniture Co., Columbia dealer, which recently had the misfortune of having a very bad fire at its location, 246 Peters street, this city, has moved to a new location at 262-264 Peters street. This live Columbia dealer opened in his new store on December 15 and enjoyed a very nice business during the holiday season.

E. W. Macon, E. D. Jordan and F. Miller, Columbia salesmen of the local branch, spent several days during Christmas week in the Atlanta branch office. All of them report that conditions in their respective territories are very favorable and that they are looking forward to one of the largest years ever during 1923.

E. E. Hyde, manager of the Bonds Graphophone Shop, Nashville, reports that the "Four o'Clock Blues" on Columbia record A3729 is proving to be the largest selling record of this nature ever released by the Columbia Co. To date, he states, he has sold seven hundred and fifty of them. It was released December 15. Mr. Hyde's stock was exhausted at noon, Saturday, December 23, and from then until the time he closed, he says, he had three hundred and fifty calls for this number.

R. F. Bibb, manager of the Stewart-Williams Co., Springfield, Tenn., has been getting some very fine results from sending a circular letter, with a classified list of records attached, to his entire mailing list. Mr. Bibb says that his record and Grafonola sales were increased 60 per cent during the Christmas season as a result of this list of records sent to his customers.

News From Other Points South

Walton & Co. and R. L. Stulce Furniture Co., Chattanooga, Tenn., have just completed two of the most successful Grafonola sales in the history of that city. During the sale of R. L. Stulce some eighty odd instruments were sold in about ten days. Walton & Co.'s sale began on the fifteenth of December and continued throughout Christmas week.

In the last issue of The World we reported that Columbia Dealer J. A. Cunningham, of Jacksonville, Fla., had just completed a most successful Grafonola sale and that he planned to have another one before Christmas. His last sale of the year 1922 began December 15 and ended the twenty-third of the month, with one hundred and fifty Columbia Grafonolas sold. Other Columbia dealers in Jacksonville, Chadwick Furniture Co. and the South Jacksonville Furniture Co., reported splendid sales during the holiday season.

The Winget Jewelry Co., Gastonia, N. C., has been obtaining splendid results from calling its customers to the telephone and playing the late record releases. Quoting George L. Rawlings, of this company: "When business gets dull and it seems as if there were none to be had we have our record clerks call our customers over the phone and broadcast the latest records. Of course, this is not as good as the radio, but you would be surprised at the number of our customers that come in and ask for the record that we played for them over the phone."

Rosa Ponselle, Metropolitan Opera star and exclusive Columbia record artist, recently appeared in Orlando, Fla., in an all-star concert and scored a huge triumph. Mather-Wiley-Estes Co., Columbia dealer, advertised her extensively in the "Program," installed a very attractive window and co-operated in other ways.

BLOOM CANDIDATE FOR CONGRESS

Sol Bloom, music publisher, former Victor jobber and builder of several theatres in New York City, has been nominated by the Democratic organization of the Nineteenth District, New York, as candidate for Congress in the special election to be held January 31 to elect a successor to Samuel Marx, who died shortly after his victory in the last election. Mr. Bloom was one of the most aggressive talking machine men in the metropolitan district until the building business claimed him.

EXCELLENT OUTLOOK FOR VITANOLA

Company Enters New Year With Substantial Volume of Orders on Its Books and Main Problem Is One of Production

SAGINAW, MICH., January 8.—According to the officers of the Vitonola Talking Machine Co. the company has been so busy endeavoring to replenish in some measure the greatly depleted stocks found after the holidays that there has been little time to consider future prospects.

The Vitonola Co. has entered 1923 with a very substantial volume of unfilled orders on hand and the problem for the next few months at least will be to take care of those orders and of the current demand.

An interesting and promising feature of the business is that a number of dealers who have not been heard from for two or three years came back into the fold with the business revival and have been distributing very satisfactory numbers of Vitonola machines.

The company is maintaining an exhibit at the Chicago Furniture Market and is anticipating the usual good results from the display of its line before the many furniture buyers who visit that exhibition each year.

Taking it all in all the company officials declare "everything will be glad and glorious during 1923," which sums up the situation.

LIBRARY SETS FOR DEALERS

The G. T. Williams Co., Inc., Victor distributor, Brooklyn, N. Y., sent its many friends in the trade a library set as a Christmas greeting. The metal parts are trimmed in gold and nickel and make an attractive as well as useful article for the desk.

INCREASES CAPITAL TO \$150,000

BRIDGEPORT, CONN., January 3.—The Alfred Fox Piano Co., of this city, has increased its capital stock from \$50,000 to \$150,000.

DOCTOROW REPRESENTS KRASCO

Well-known Manufacturers' Representative Handling Krasco Motors in This Territory—Has Wide Acquaintance in Trade

D. R. Doctorow, manufacturers' representative, with headquarters at 51 East Forty-second street, New York, was recently appointed sales representative in this territory by the Krasco Mfg. Co., Chicago, manufacturer of Krasco motors. This important deal was closed by D. S. Root, vice-president of the Krasco interests, who makes his headquarters at the New York offices of the Krasco Mfg. Co., 128 West Forty-second street.

During the past few months the Krasco motor has won signal success in all sections of the country and has been adopted by a number of well-known talking machine manufacturers as part of their standard equipment. Mr. Doctorow, through his wide experience in the trade, is in a position to give this motor splendid representation in this territory.

VICTOR TRAVELERS IN CONFERENCE

Report at Factory During Holidays to Discuss Business Plans for New Year

During the Christmas holidays the entire staff of the traveling department of the Victor Talking Machine Co., with the exception of R. P. Hamilton, who travels California and Nevada, reported at the factory and spent several days in conference with the Victor Co. executives regarding the business plans for the new year. After brief vacations spent at their homes, in some instances, the travelers returned to their respective territories.

Miss Grayce Van Couttren recently resigned from the organization of H. O. Hartley, Victor dealer, Galva, Ill., and is now connected with the Victor department of W. H. Lyman & Co., Kewanee, Ill.

**JANUARY, FEBRUARY and MARCH
The Heavy Record Selling Months of the Year**

Are You Prepared?



**THIS DEALER IS PREPARED!
NEW UNICO DEPARTMENT OF DERBYSHIRE BROS.**

1923 demand will show radical increase.

Adequate sales facilities will produce a harvest of record sales during the first three months of the year.

The UNICO SYSTEM will *DOUBLE* your facilities overnight—and at moderate cost.

3,300 dealers have increased sales and profits thru UNICO EQUIPMENT.

You can do likewise.

Consult our nearest branch TODAY.

UNIT CONSTRUCTION COMPANY

RAYBURN CLARK SMITH, *President*

NEW YORK, N. Y.
299 Madison Ave.

58th Street and Grays Avenue, Philadelphia, Pa.

CHICAGO, ILL.
30 N. Michigan Blvd.

DALLAS, TEX.
209 Dallas Bank Bldg.
SAN FRANCISCO, CAL.
275 Post St.

NEW ORLEANS, LA.
506 Marine Bank Bldg.

SALT LAKE CITY, UTAH
150 Main St.
DENVER, COLO.
1642 Arapahoe St.



H. A. MOORE & CO., LTD. (Sales Agents)
Premier House, London (W.C.I.), England

Store Equipment of Quality and Design

Hearing Rooms
Record Racks
Service Counters

Display Cases
Musical Instrument
Cases, etc.

ZIMMERMAN BITTER CONSTRUCTION CO.

Offices, Factories and Warerooms—325-327 East 94th Street

New York City

IMPORTANT NEW POSTS FOR TWO VICTOR CO. OFFICIALS

J. S. Macdonald Appointed Associate Director of Artists and Repertoire Department as Assistant to C. G. Child—Frank K. Dolbeer Advanced to Sales Managership

The Victor Talking Machine Co. has just announced several important changes in official personnel and in the designations and duties of certain executives of the company, becoming effective on January 8.

J. S. Macdonald, who for the past two years has been sales manager, has been advanced to



John S. Macdonald

the post of Associate Director of Artists and Repertoire, and in that capacity will act as direct assistant to C. G. Child, who has been designated as Director of Artists in Repertoire Department, although continuing the work which he has handled so ably for a number of years past in building up the prestige of the Victor record catalog.

Mr. Macdonald in his new post will divide his time between duties at Camden and New York and travel in the interest of the record catalog and will maintain contact with musical interests and with the trade.

Mr. Macdonald, before becoming sales manager at the Victor factory, was in charge of the recording rooms in New York and his experiences in that connection will unquestionably prove of great service to him in carrying on his new duties.

The other promotion is that of Frank K. Dolbeer, formerly head of the Traveling Sales Department, to the post of sales manager, with full charge of the operation of the Sales Department. Mr. Dolbeer will handle or delegate the handling of all ordinary business with the trade and will relieve Ralph L. Freeman, Director of Distribution, of many of his present



Frank K. Dolbeer

duties in order that the latter may give more time to work of a general character.

Mr. Dolbeer's long and successful experience in looking after the sale and distribution of talking machine products is too well known to require comment, and he is particularly well qualified to fill with ability the post to which he has been promoted.

LANDAY BROS. INCREASE CAPITAL

New York Victor Wholesalers and Retailers Add Greatly to Capitalization

Landay Bros., Victor distributors with headquarters in New York and operating several retail stores in the metropolitan district and adjacent territory, have increased their capitalization from \$25,000 to \$1,000,000. This move is in line with the policy of expansion which Landay Bros. have adopted due to the rapidly growing business of the firm.

It will be remembered that a complete line of musical merchandise was installed in the Forty-second street, New York, store of the firm, and it is the intention to introduce similar lines in the other stores operated by the company.

NEW HOME FOR ROTH MUSIC STORE

COLUMBUS, O., January 3.—The Roth Music Store, 186 South High street, this city, operated by David Roth, has secured a ten-year lease on spacious quarters, consisting of a storeroom and basement on High street. Mr. Roth is one of the best known music dealers in this vicinity and he has built up a large business in pianos and musical instruments.

NOW \$1.50

To the Consumer

RADIO has had its fling, so we will get back to
PHONOGRAPH SUPPLIES

**The LIDSEEN
FIBRE NEEDLE
CUTTER**

Sharpens the needle without removing it from the tone arm of the machine



Jobbers, line up on this

LIDSEEN

832-840 So. Central Ave. CHICAGO

SECOND YEAR SUCCESSFUL LEADER

Canada Patent Applied

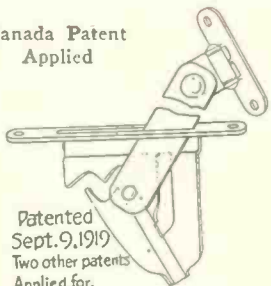

The Most Dependable and Inexpensive Lid Support on the Market

The bottom plate is constructed of one piece of metal and it works automatically perfect. No parts to go out of order. The hinges are made in two styles—

flexible and bent. Samples on request.

STARMACHINE & NOVELTY CO.

81 MILL STREET BLOOMFIELD, N. J.
G. L. LAING CO., Canadian Distributor
41 Richmond St., East, Toronto, Ont.

THOS. F. GREEN REMEMBERED BY STAFF

As a mark of their esteem and affection the staff of the Silas E. Pearsall Co., New York Victor wholesaler, presented Thos. F. Green, president of the company, with a beautiful set of tobacco pipes. The presentation was made on Christmas Eve and Lloyd L. Spencer, sales manager of the company, officiated as toastmaster, performing his duties with his usual ability. The set of pipes is not only elaborate, but practical in its make-up, consisting of seven pipes mounted in gold and made of the finest shell briar available.

NEW CLEANING FLUID ON MARKET

Varnol Introduced to Talking Machine Trade by Varnol Co.—Has Many Distinctive Features

The Varnol Co., of New York, has just placed on the market a cleaning fluid known as "Varnol," which the company states "clears the way to good music." This preparation, which is the invention of G. W. Shodde, cleans old records so thoroughly that the original beauty of the music is restored and it also cleans off the wax coating on new records, thereby enabling the purchaser to secure maximum satisfaction. Varnol is packed in a one-ounce bottle, containing sufficient fluid to clean 150 double-face records, and Mr. Shodde has already received substantial orders from jobbers and dealers who are keenly interested in the new preparation.

SHOW EXHIBIT PRODUCES BIG SALES

MILWAUKEE, Wis., January 5.—The Luebtow Music Co., of this city, featured the Sonora to excellent advantage at the Food and Household Show held in this city recently. The show was attended by about 100,000 people during the



Exhibit of the Luebtow Music Store week and Sonora literature was liberally distributed. Several sales were made at the booth and the show, which was held under the auspices of the Milwaukee Journal, was a signal success.

NATHAN GARFINKEL TO CONCENTRATE

Nathan Garfinkel, majority stockholder and treasurer of the Mutual Phono Parts Mfg. Corp., manufacturer of tone arms and sound boxes, New York, has decided to devote his entire time and attention to the talking machine business. He has been connected with the automobile accessory business for quite some time and is well known in that line. However, business has increased to such an extent that in the future he will direct all his efforts to the success of the Mutual Phono Parts Mfg. Corp. Mr. Garfinkel assumed his duties on January 2 and has already taken measures to increase production and enlarge the present factory.

DELIVERS INTERESTING ADDRESS

LANCASTER, PA., January 8.—An interesting address on "Music Appreciation and How It Is Acquired" was recently delivered before the members of the Quota Club at a dinner meeting in this city by Miss Esther Gatewood, of the Victor Talking Machine Co. The talk was illustrated with records played on a Victor machine loaned by the Donovan Co., Victor dealer of this city. While here Miss Gatewood also addressed students of the Stevens High School on "Music as a Factor in Education."

BUST OF CARUSO FOR NEW YORK

The finished bust and monument of the late Enrico Caruso, world-famed artist, ordered by the Italians of New York in honor of their deceased countryman, has been delivered to the brother of the great tenor by Filippi Cifariello, Naples, Italy, and it will be sent to New York.

NEW UNIT INSTALLATIONS

Equipment for Dealers in New York and New England Territories Show Active Plans for 1923 Business Is Now Well Under Way

W. K. Badger, in charge of the New York and New England territories of the Unit Construction Co., of Philadelphia, Pa., reports that the past year found many new Unico installations made in the territory and that there was a marked tendency on the part of all dealers to further enlarge and beautify their warerooms throughout 1923.

A recent installation that attracted considerable attention is that of the Gibbs Piano Co., of Springfield, Mass. This consists of complete Unico equipment with six rooms, record department, cornice and column treatment and offices. Installation was finished in ivory and proved very attractive.

The Jamaica Music Co., of Jamaica, L. I., Victor and Brunswick dealers, recently had installed, by the Unit Construction Co., in its

warerooms at 21 Sutphin boulevard, a complete Unico equipment, consisting of six rooms with all accessories. These warerooms are advantageously situated opposite the big Jamaica terminal of the Long Island Railroad, and, in addition to local business, do a considerable commuters' trade as well. Miss Evelyn Bebell, owner and general manager of this music shop, is a hustler and a firm believer in going out after business. Several automobiles are owned by the company and are steadily employed in canvassing the residential districts within a wide radius of the headquarters.

Harry A. Beach, vice-president of the Unit Construction Co., was a recent visitor at the New York offices when he stopped off on his way to New England and New York State points. Rayburn Clark Smith, president of the company, also visited the New York offices during the early part of the month.

The Victor department of the J. B. Spilman store, Rolla, Mo., is holding Saturday concerts which are attracting considerable interest.

Don't Be Caught Without Bubble Books!



Christmas started the Bubble Book habit in many new homes—more mothers than ever now know the joy of a serene household on those heretofore trying winter days, when obstreperous youngsters have to be kept indoors.

You undoubtedly helped to start the Bubble Book habit. You helped many mothers to solve the problem of indoor entertainment for their children. These same mothers will soon be coming to you for new Bubble Books—for once children make the acquaintance of the books "that sing" they aren't happy until they have *all* of them.

Don't let your customers find you unprepared for their reorders. Keep your Bubble Book stand filled. Remember that Bubble Books are *year-round* sellers!



BUBBLE BOOKS "that Sing"

By RALPH MAYHEW and BURGESS JOHNSON

Illustrated by Rhoda Chase

When you sell one you sell a habit and when you sell a habit, you're building business.

HARPER & BROTHERS, BUBBLE BOOK DIVISION
Established 1817 Franklin Square New York, N.Y.

HAPPENINGS IN THE DOMINION OF CANADA

BRISK HOLIDAY TRADE ENJOYED IN TORONTO TERRITORY

Scythes-Vocalion Co., Ltd., Introduces New Vocalion Portable—New Record Distributed by Starr Co.—M. S. Davis a Visitor—Victrolas for Schools—Month's News

TORONTO, ONT., January 8.—The Scythes-Vocalion Co., Ltd., 29-31 Alice street, this city, Canadian distributor of Vocalion phonographs and records, has introduced a portable Vocalion phonograph to the Canadian market. It is very compact and large sales are expected.

The Starr Co. of Canada, Ltd., London, is now issuing a new section in its monthly record supplements to be known as the Goldseal record and to be retailed at eighty-five cents. It is intended to introduce two of these Goldseal eighty-five-cent records each month in addition to the regular list of Starr sixty-five-cent records. Starr dealers who have been approached on the subject have expressed themselves highly pleased with the innovation, according to W. D. Stevenson, vice-president. A series of songs by H. Rutburn McDonald, Toronto baritone, has been recorded and it is expected that the Starr Co. of Canada, Ltd., London, will release one or two of these records each month for the next several months.

Miss Mac Skilling, of the Columbia Co.'s educational department, gave a demonstration of Columbia educational records to local school teachers recently.

M. S. Davis, of the Encore Sales Co., New York, recently visited the Musical Merchandise Sales Co., Canadian distributor of the Encore record repeater.

The Larsson Phonograph Co. has commenced business at 517 Bloor street, West, this city. In addition to the Larsson line the firm is handling the Vocalion.

M. Forsythe, "His Master's Voice"-Victor dealer in Aurora, has been successful in selling several portable Victrolas, Style 50, to the public school of Aurora recently. Mr. Forsythe also sold at the same time several sets of "His

Master's Voice"-Victor health exercises, after same had been demonstrated to the teachers and scholars by Charles Gorden, of the traveling staff of His Master's Voice, Ltd.

Yerkes' S. S. Flotilla Orchestra, which makes Vocalion records exclusively, recently spent two weeks here at the Hippodrome. Local dealers cashed in on the opportunity to feature records by the orchestra.

A trade visitor to Canada recently was N. Cohen, president of the Wall-Kane Needle Mfg. Co., Inc., Brooklyn, N. Y.

C. V. Lindsay's, Ltd., Ottawa branch recently conducted a series of weekly recitals for children in its Columbia and Sonora phonograph department. Small souvenirs were distributed among the youthful visitors. A lady demonstrator was in charge of the first recital and she explained the various compositions as they were played.

Toronto's latest and most exclusive phonograph shop, Brunswick Hall, 228 Yonge street, was recently opened to the public and although the interior decorations were not entirely completed this did not interfere with establishing what will probably be a record in the phonograph business for an opening day.

This new shop is surely destined to be a center of attraction in the music world, as it presents to the public a splendid array of Brunswick phonographs in every style and finish. On the opening day there were approximately one hundred Brunswicks on exhibit. A complete stock of Brunswick records also has been installed.

Van and Schenck, Columbia artists, recently appeared in a vaudeville sketch at Shea's and were billed as "The Pennant Winning Battery of Songland."

twelve most popular Starr-Gennett records, the popularity to be judged according to the lists sent in by the competitors. The records to be chosen under the following heads: Three high-class songs, three old-time songs (such as "Old Folks at Home"), three dances and three marches. The person whose list agrees with the order of popularity according to the voting can select any twelve records desired for the prize.

A. C. Skinner, Sherbrooke, Que., plans to handle the complete Edison line exclusively in the future.

Quite a considerable number of Sonora and Columbia machines were purchased at the last minute from C. W. Lindsay, Ltd., as Christmas gifts and this firm experienced considerable difficulty delivering them.

Charles Culross reports wholesale business in Aeolian-Vocalion lines as tip-top, both as to machines and records. Sonora retail sales with this firm are and have been good.

TRADE ACTIVITIES IN WINNIPEG

Cassidy's, Ltd., Puts on Co-operative Campaign to Boost Columbia Products—Tie-up With Theatre Produces Excellent Results.

WINNIPEG, MAN., January 8.—Cassidy's, Ltd., distributor of Columbia Grafonolas and records, has been testing the possibilities of co-operative advertising. It arranged with the Allen Theatre Orchestra, which, by the way, is one of the best musical organizations in the city, to make a special musical item of the "Parade of the Wooden Soldiers," a record which the Columbia people are featuring. In connection with this they held a window dressing competition among dealers for the best display featuring the "Parade of the Wooden Soldiers," also working into the display the fact that this music was being played at the Allen Theatre.

Six thousand cards were mailed to record buyers, with descriptive matter of the latest Columbia records and announcing the fact that they were being played all week at the Allen Theatre. Large sales resulted.

GATHERING VICTOR INVENTORY DATA

The Victor Talking Machine Co. has sent out to Victor dealers throughout the country inventory sheets so that authentic data can be obtained by the company on stocks of records and machines on hand by dealers on December 31. The data thus obtained will be used as a basis for estimating manufacturing volume during 1923.

J. B. Ralston is the new manager of the Taylor Bros. Music Co., Moberly, Mo. He is the brother of Lawrence Ralston, who manages the company's store in Columbia. Both have financial interests in the enterprise.

FAIR DEMAND IN ALL BRANCHES OF MONTREAL TRADE

Console Models Lead Holiday Demand—Compo Co., Ltd., Installs Special Machinery to Speed Output—New Strand Agencies—Planning a Music Week—Feature Starr-Gennett Records

MONTREAL, CAN., January 6.—Inquiries made at the various retailers of talking machines elicited the information that holiday trade was, on the whole, equal to that of last year and in a few instances slightly ahead. Dealers handling radio sets enjoyed their first Christmas sale, but it did not come up to expectations.

Layton Bros. report a heavy sale of console models in both Edison and Brunswick instruments. A brisk demand for Columbias was also enjoyed.

Frank Ramsperger (International Music Store) reports heavy sales of Brunswick records as well as inquiries for and sales of Brunswick phonographs.

The Compo Co., Ltd., record-pressing plant at Lachine, Que., has installed especially constructed machinery in order to increase the capacity of the plant. This, with the working of the pressing plant twenty-four hours per day, if necessary, guarantees adequate production of Apex records to meet all demands.

The Strand phonograph, which is being distributed in Montreal by R. L. Chilvers, has been taken on lately by the following firms: Layton Bros., Ltd.; J. W. Shaw & Co., Woods Music Store, J. Donat Langelier, Ltd.; Dupuis Freres and J. H. Mulhollin Piano Co.

Goodwins, Ltd., drew considerable publicity to its Brunswick department through billboard advertising in prominent locations scattered throughout the city.

Jas. A. Ogilvys, Ltd., department store is now carrying the complete line of Starr phonographs as well as a full assortment of Gennett records.

The Delphic Study Club's plan to give Montreal a music week is meeting with general approval. A number of the city's leading musicians have promised to help the project with contributions of free concerts.

Jas. A. Ogilvy's, Ltd., this city, is putting on a new stunt in order to familiarize the public still further with the merits of Starr-Gennett records and at the same time increase the monthly mailing list by securing new names.

A selection of any twelve records will be given free to the person who correctly anticipates the

Talking Machine Springs and Repair Parts

NONE BETTER IN QUALITY NONE LOWER IN PRICE

THE RENÉ MANUFACTURING CO.
MONTVALE, NEW JERSEY

| | | |
|--|--|--|
| <p>Cable Address Reg'd "Phila--Phila."</p> <p>Exclusive Distributor- ships Now Being Granted. Request Catalog 177T</p> | <p>"TALKS FOR ITSELF"</p> <p>PENNSYLVANIA PARLA RADIO LABORATORIES</p> <p>APPARATUS</p> <p>SUBSIDIARY OF INTERNATIONAL MICA COMPANY</p> <p>PHILADELPHIA, PA.</p> | <p>Long Distance Phone Baring 0335</p> <p>Made Specially for the Talking Machine Trade</p> |
| <p>VICTOR, COLUMBIA, PATHE, EDISON and SONORA JOBBERS, WRITE FOR EXCLUSIVE DISTRIBUTORSHIP</p> | | |

GENERAL PHONO. CORP. ENLARGES

New York Distributing Division Secures Additional Space at Present Location—Many New Okeh Record Agencies Recently Opened

The New York distributing division of the General Phonograph Corp., which has recently moved into new offices at 15 West Eighteenth street, New York, has just taken over an additional floor at this address to take care of the large amount of business which the company has booked during the past few months. The concern formerly occupied the ground floor of this large loft building and last month the second floor was secured and is now being used for office space as well as for the packing and delivery of records to Okeh dealers.

E. B. Shiddell, general manager of the company, was very much pleased over the splendid showing made by his company during the last three months and especially during the month of December when sales totals showed a more than 100 per cent increase over the figures of last year for the same period. A large number of new Okeh dealers have been taken on and from all indications additional dealers will bring the total up considerably during the coming year. "Despite the fact," stated Mr. Shiddell, "that record business was reported slow during the month of December we were able to show a large increase, and from all indications 1923 promises to be one of the most prosperous years in the history of the talking machine business. With our present facilities and well-organized sales force we are prepared to give Okeh dealers in our territory a high-class service in every respect, which will be reflected, no doubt, in a corresponding increase in sales."

Plans are now being made for a formal opening of the new quarters of the company which it is expected will take place about the first of February. At that time the entire organization will meet and officials of the General Phonograph Corp., headed by Otto Heineman, president, will be invited to attend and take part in celebrating this event, which, judging from the program, will be some affair.

CONDUCTING CAMPAIGN ON SPRINGS

Everybody's Talking Machine Co. Staging Drive Directed Mainly to Popularizing "Honest Quaker" Springs Throughout the Trade

PHILADELPHIA, PA., January 8.—Although supplying to the trade every part used in the talking machine, Everybody's Talking Machine Co., of this city, is conducting a campaign centering to a large extent on "Honest Quaker" springs. The name, which was selected by this company to represent its product some time back, is particularly descriptive. Quality has been held foremost in the production of these springs and these yellow labeled boxes are now to be found in a large majority of talking machine ware-rooms and repair shops throughout the country. A policy of a special spring for each purpose has been adopted. In recent literature prepared by the company a grouping of these boxes is shown, the numbers running from seventeen to fifty-eight. The line is produced in a wide range of lengths and widths and for practically all makes of machines.

STARR PIANO CO. LEASES FLOOR

The Starr Piano Co. has leased a floor at 9 East Thirty-seventh street, New York, from Douglas L. Elliman & Co.

IMPROVEMENTS AT TRAFFORD CO.

Mason City, Ia., Concern Installs Most Modern Conveniences for Patrons

MASON CITY, IA., January 8.—The Trafford Co., Inc., has recently added new fixtures to its store, which helps to make it one of the finest music stores in the State of Iowa. This firm has also rearranged its stock of musical instruments, which gives the store a very attractive appearance. Features are hearing counters for demonstrating records. These counters permit the hearing of records without disturbing any-

one and they eliminate the use of booths. These new counters make it possible for more records to be played in less time and without confusion. The machines are automatically wound.

The Trafford Co. has also installed new cabinets and counters for sheet music and music books. With the space saving accomplished the company now uses the rear room for the display of upright and grand pianos, player-pianos. Victrolas and Brunswick machines are shown in the center room. The enormous stock of records carried by this house is now filed in the front room instead of in the rear as before.

"One handle handles it"

Outing

The Ever-Seasonable Portable

MOVABLE MUSIC



**ALL YEAR 'ROUND
RUN OF SALES**

Size: 8 in. x 14 in. x 15 in. Patent Pending

MORE CONVENIENT than TABLE Machines.
TONE Quality EQUAL to LARGE Machines.
Finish Same as Any Large Phonograph.

A Wonderful GIFT

Outing

TALKING MACHINE CO., Inc.

A. J. COTE, President
MT. KISCO, N. Y.

Oak and

Dealers in Mexico and Cuba should send orders and inquiries to
R. C. ACKERMAN
 291 East 162nd Street New York, N. Y.
 Foreign Export—CHIPMAN LIMITED
 8-10 Bridge Street New York City
 Cable Address, CHIPMUNK, New York

**Mahogany
Finishes**

JOBBERS:

| | | | |
|--|--|---|---|
| <p>GENERAL PHONOGRAPH CORP. New York Distributing Division 15 West 18th Street New York, N. Y.</p> <p>CABINET & ACCESSORIES CO., 145 East 34th St., New York, N. Y.</p> <p>BRISTOL & BARBER 3 East 14th St. New York, N. Y.</p> <p>A. C. ERISMAN CO., 174 Tremont St., Boston, Mass.</p> | <p>GEO. C. ULRICH & CO. 56 Estey Bldg., Philadelphia, Pa.</p> <p>ART EMBROIDERY CO. Louisville, Ky.</p> <p>IROQUOIS SALES CO. 210 Franklin St., Buffalo, N. Y.</p> <p>UTICA'S GIFT & JEWELRY SHOP Utica, N. Y.</p> <p>DAVENPORT PHONO. & ACCESS. CO., 217 Brady St., Davenport, Ia.</p> | <p>VOCALION CO. OF OHIO Cleveland, O.</p> <p>BURNHAM, STOEPEL & CO. 101 East Larned St., Detroit, Mich.</p> <p>WALTER S. GRAY CO. 942 Market St., San Francisco, Cal.</p> <p>STEWART T. M. CO., Indianapolis, Ind.</p> <p>J. K. POLK FURN. CO. 294 Decatur St., Atlanta, Ga.</p> | <p>M. & M. DISTRIBUTING CORP., 5 So. Wabash Ave., Chicago, Ill.</p> <p>STERLING ROLL & RECORD CO. 137 W. 4th Street, Cincinnati, O.</p> <p>RICHMOND SPORT & SPECIALTY SHOP (Newton Corp.) 616 E. Broad St. Richmond, Va.</p> |
|--|--|---|---|

DIAMOND PRODUCTS IN NEW HOME

Manufacturer of Juvenile Console Talking Machine Moves to Fifth Avenue Quarters as the Result of Its Rapidly Growing Business

The Diamond Products Corp., manufacturer of the Diamond juvenile console talking machine, which has met with great success in the past year, is now located in its new offices in the Fifth Avenue Building at 200 Fifth Avenue. This concern was formerly located at 25 West Forty-third street, where it had its offices for several years past, but due to the increase in business in its juvenile console machines and children's furniture, which the company inaugurated a year ago, it was found necessary to secure larger quarters. These new offices are ideally located and the additional space will be used to advantage in arranging a suitable display space for these products. H. B. Foster, general manager of the company, in commenting upon this new move, stated that with this additional space his company would be able to show to advantage the juvenile talking machine products to dealers who visit its offices and consequently give the dealer a more efficient service. "Our plant at Oswego, N. Y.," Mr. Foster stated, "has been running to full capacity for many months past and from all indications the coming year promises to be the most prosperous one we have yet enjoyed. Our production, so far, has been satisfactory, but we expect to increase our output by more than double this coming year."

J. B. Price, Middle West representative of the company, and Lee Conover, who covers New England territory, both spent the holidays in New York City with their families. On February 1 they both start out again for an extended trip through their respective territories with the expectation of booking orders that will make 1923 the largest year they have yet enjoyed. Both Mr. Price and Mr. Conover are hustlers and let no opportunities pass them by.

RETURNS FROM COAST TO COAST TRIP

Rayburn Clark Smith, President of Unico Construction Co., Concludes Extended Trip in the Interest of Unico Equipment

PHILADELPHIA, PA., January 5.—Rayburn Clark Smith, president of the Unit Construction Co., manufacturer of Unico wareroom equipment, returned to headquarters in this city after an extensive six weeks' trip throughout the country. Mr. Smith was thoroughly impressed by the general spirit of optimism regarding 1923 manifested by dealers in all sections of the country, for Mr. Smith's trip carried him as far as the Pacific Coast and back again through the Southern territory. Sixteen important trade centers in the country were covered. He found business universally good, but particularly big on the Pacific Coast. Mr. Smith expects that the optimistic and energetic spirit manifested will result in big development of business in the talking machine trade during 1923.

George A. Lyons, Eastern sales manager of the company, is at present calling upon the trade in the Ohio territory.

ROBERT B. WHEELAN IN THE VAN

President of Health Builders, Inc., New York, Was First to Utilize Talking Machine Records for Sending Personal Message to the Trade

While keeping abreast or even ahead of times is one of the qualities of Robert B. Wheelan, president of Health Builders, Inc., New York, he recently had the distinction of finding himself two years ahead of what was claimed to be the latest development in the field. One of the metropolitan dailies described as a novelty in its Sunday edition greetings sent by a man to his many friends in the form of a personal message recorded on a talking machine record which is referred to elsewhere in The World. This was described as a brand new development. The

trade will remember that in December, 1920, Mr. Wheelan used this novel form to greet his many friends throughout the industry, which was commented on in a subsequent issue of The Talking Machine World.

COLUMBIA DEALER OPENS NEW STORE

BALTIMORE, MD., January 6.—L. K. Snyder, who recently opened an attractive music store on Monument street, has been achieving pleasing success in the introduction of Columbia Gramophones and records to his clientele. At the

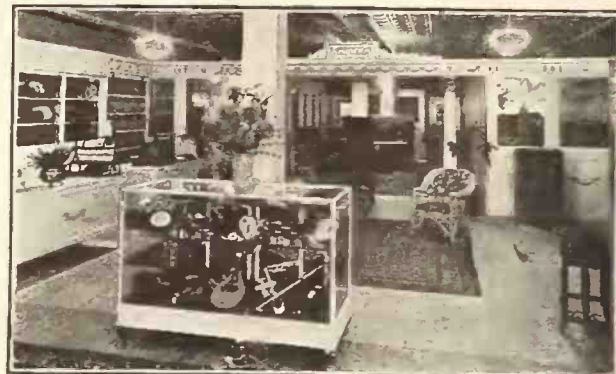

L. K. Snyder's New Store

formal opening of this attractive establishment crowds of friends were on hand to congratulate Mr. Snyder on the comfortable and homelike appearance of his store. Van and Schenck, exclusive Columbia artists who were playing in Baltimore at the time of the opening of the store, were on hand to delight the guests with some of the hits they have recorded on Columbia records.

FILES BANKRUPTCY PETITION

WATERTOWN, N. Y., January 2.—George D. Schuyler, well-known piano dealer of this town, has filed schedules of bankruptcy with the U. S. District Court showing assets of \$5,000 or \$6,000 and liabilities of about \$9,000.

Are You Prepared for the 1923 Record Rush?

The sale of records for 1923 is going to reach the highest point of its ascent this winter. But records must be displayed just like any other merchandise to sell.

Send for our catalogue showing 40 Displays for increasing your sales. You can procure it either from your jobber or direct from

UNIVERSAL FIXTURE CORPORATION
133-135-137 West 23rd Street New York



No. 580



No. 566

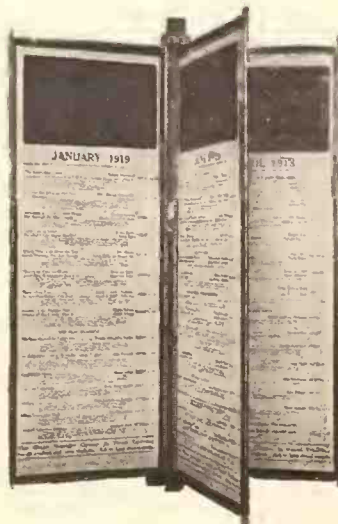

No. 588



No. 553

C I N C I N N A T I

*Overflow From Holiday Business Keeping Many Dealers Busy—
All Lines Enjoy Demand—Cheery Comments of Leading Merchants*

CINCINNATI, O., January 9.—You would think, from the glowing reports made by Cincinnati dealers in talking machines and kindred goods, that nothing could possibly be heard in the streets and byways of the city but the lyric strains of many phonographs, of Victrolas, of Brunswicks, of Edisons, of Columbias, of Vocalions, of Starrs, of Granbys, of many others, all pouring out the melodies that made the recent ultra-musical Christmas.

All in all it was a satisfactory holiday period. Dealers, wholesalers and retailers all agree as to this. One of the best—indeed, the best—in years! From the beginning of the “early shopping” period until the first of the new year, the trade in talking machines, records, needles, albums—all accessories—was excellent.

One among the many concerns which have cause for gratification is the local branch of Widener's Grafonola Shops, dealing in Victor, Columbia and Granby goods, of which Morris Fantel is manager. “Our holiday business,” said Mr. Fantel, “was better than that of 1919, which was a banner year. We had, this year, a wonderful business indeed. Both our cash and our sales went over our quota, and we have received congratulations from the main office at Boston on this achievement. The year of 1922 shows a fine profit. Beginning October 1 and continuing throughout November and December business was splendid. December, especially, went far above expectations.

“January looks like a winner. We have been so busy that we are still working on last year's business, which helps to make January good. But 1923 should be a profitable year for everyone. Just now the prevalence of illness throughout the city is causing us to lose some immediate business. One day recently we called on a score of prospects, and more than half of them were ill.”

J. E. Henderson, sales manager of the Brunswick-Balke-Collender Co., is another to report a good year, a splendid December and holiday trade, and a bright outlook for 1923. “Nineteen twenty-two was the largest year in the history of the Cincinnati branch,” said Mr. Henderson. “It marked a 25 per cent increase over last year. December, 1922, was the best month ever experienced by this branch. The prospects for the new year are very good. I really believe that 1923 will be another 1919! Business in console types has been a feature of the market. This is at present the most popular type of machine, and the trade is going to it.”

E. I. Pauling, of the Starr Piano Co., said: “Our December business was the best in the history of this store. Excellent business is in sight for January.”

At the Otto Grau Piano Co., which deals in Brunswick, Victor and Vocalion products, gratification was expressed at the fine business done during the last three months of the year and December especially. J. F. Van Court said: “We had the best December we ever had. We also had a very good year, chiefly because of the fine trade of the last three months. We did an excellent business in new model Brunswick consoles. Victor and Aeolian goods were also in great demand.

“The outlook for 1923 is very promising. We expect to do a great deal with our new line of Aeolian goods, as well as with those other successful lines—Victor and Brunswick. We probably will spend more than ever on advertising, as the steady campaign we conducted throughout almost all of last year was of great benefit. Our newspaper advertising, especially, excited much favorable comment, and J. A. Jacober, who is in charge of our advertising, has many more effective ideas to put into effect this year.”

Ben L. Brown, manager of the Sterling Roll & Record Co., said: “The holiday trade this year was 60 per cent better than that of last year. I attribute this fact in a measure to the success we have had with the Strand phonograph, made by the Manufacturer's Phonograph Corp. Last year at Christmas time we had just taken over this account, and it built itself up in such a way that its influence was gratifying throughout the year. Trade in Okeh records was uniformly excellent. I find that all dealers are optimistic for 1923.”

Richard Spaniard, of Maysville, Ky., one of the dealers of the Sterling Roll & Record Co., called at the Cincinnati office this week on business.

All Brunswick salesmen of the Cincinnati district attended a sales conference held in Cincinnati December 26 to 28.

Ohio Talking Machine Co., jobber in Victrolas and records, enjoyed a fine holiday trade and a fine year, according to Mr. North, who said: “Reports from all of our dealers in the district make it plain that December was a banner month. All are sold clear out, or nearly so, and they are in good shape to handle new stock. We were able to supply a great demand for all types of machines. The new Victor flat-top console was perhaps the most popular of all our machines, but all console types were in great demand. The outlook for 1923 is encouraging. Orders already are coming in. We have good reports from the tobacco districts of Kentucky, from the mining sections of West Virginia and the farmers of Indiana. It should be a splendid year for all dealers.”

A. H. Bates, president of the Ohio Talking Machine Co., probably will go to Indianapolis next week to see the company's retailers. Mr. North will go to Louisville on business.

WANTED! Salesmen

To safeguard and direct the normal expansion of our Phonograph sales, and to serve as leaders in a far greater expansion, soon to come, this Company offers to five men of standing and ability the opportunity which comes to few more than once in a lifetime.

These men will be territorial representatives of the fastest growing and most progressive Phonograph manufacturer in the world.

To each of them will be soon entrusted a message of such startling importance to the Phonograph Trade that it can be adequately delivered only by men whom the trade trusts and believes.

Is your record absolutely clean? Does your trade impose absolute confidence in you? If you can answer “Yes” to both questions, you are in direct line for a far better position than the one you now hold—a position that will notably increase your earnings and your prestige.

Write—or wire—H. H. Roemer, Sales Director (personally). Your communication will be kept in strict confidence.

The business of this Company increased during 1922 more than 150% in actual completed sales.

JEWETT RADIO AND PHONOGRAPH CO.
DETROIT

JEWETT



Moore is the man who bends a carpenter's handsaw over his knee and produces music of concentrated elfin glory. Moore—with Davis playing the accompaniment on a harp-guitar—has made a novelty record for us that is a treat to hear. A-3750 should be in every collection.

Columbia Graphophone Co.
NEW YORK

NEW EDITION OF ORCHESTRA CHARTS

New Printing of "The Instruments of the Orchestra" Includes Improved Features

The Victor Co. announces that a new edition of "The Instruments of the Orchestra by Sight, Sound and Story" and an accompanying descriptive handbook will be off the press and ready for distribution in the very near future.

The new edition consists of eighteen single-face charts, 14x22 inches, showing the instruments of the orchestra in absolute accuracy of color and detail. The handbook of supplementary information, which accompanies each set of the charts, gives the origin of each instrument, its history, uses by composers, etc. These charts, together with the special Victor records 35670 and 35671 (without vocal announcement of the names of the instrument), or 35236 and 35237 (with announcement), have met with enthusiastic approval by schools everywhere because of the intimate study of the instruments of the orchestra they afford that can be made in no other way.

The illustrations in the new edition have been printed upon one side of the cards only, with the names of the instruments on the reverse side. This facilitates the handling of the cards in teaching. An eyelet replaces the cord formerly used for hanging the charts.

CHRISTMAS GIFTS FOR DEALERS

Brass cigarette boxes, for the desk, with the Victor imprint were presented by Collings & Co., Newark, N. J., to their many friends in the trade. The boxes hold 200 cigarettes and are a most useful present. The shipping department of Collings & Co. was busy for several days getting the presents away in time for the holidays.

The success of a business depends greatly on efficient salesmen—reason for hiring the best.

ENTHUSIASTIC OVER OUTLOOK

Orsenigo Co., Inc., Foresees Excellent Demand for Quality Machines During Year

The Orsenigo Co., Inc., Long Island City, N. Y., manufacturer of art talking machines, is enthusiastic over the business prospects for 1923 for machines of the better grades. In this connection the company says:

"The current year was our initial entry into the marketing of high-grade period phonographs. While we had previously manufactured under contract it was our first opportunity to give full sway to our ideas in the marketing of high-grade period talking machines.

"The success of this venture has filled us with the assurance that there is a splendid market for cabinets that are constructed in a manner to conform to the highest grade workmanship and decorations and which will make the cabinet a component part of the furnishings rather than merely a musical adjunct to the room.

"The results of the past twelve months have been most satisfactory and from the quantity of orders booked, and as far as we can see into the future, it holds much promise for surpassing the present year."

CROSLY EXHIBIT A SUCCESS

Cincinnati Radio Manufacturer Displays Line at New York Radio Show—Powel Crosley in Attendance—Many Orders Result

One of the most popular exhibits at the recent radio show in New York was the display presented by the Crosley Mfg. Co., of Cincinnati. The instruments on exhibit included Crosley models 25, 20, 15, 8 and 6, and the success already achieved by the Crosley radio set was emphasized in the orders placed by dealers at the show, together with the interest manifested by the public. Particular attention was paid to the Crosley model 25, which is a console model

embodying a number of distinctive features. The Harko Sr. model 5 was also on display, and Powel Crosley, president of the company, who visited the show for a few days, was delighted with the enthusiastic reception accorded the company's products.

GEO. W. LYLE'S VIEWS OF FUTURE

President of Manufacturers' Phonograph Co. Enthusiastic Regarding Business Outlook

Judging from experiences during the last few weeks of 1922 George W. Lyle, president of the Manufacturers' Phonograph Co., Inc., is convinced that the demand for instruments during the greater part of 1923, at least, will tax production facilities. In this connection he says:

"Nineteen twenty-two is a record and 1923 a prediction, naturally. But based on the fact that we know precisely where a total of at least three times as many Strands could have been sold if we had been able to produce them, you may be sure I have complete confidence in our 1923 prospects. That is the Strand point of view. The policy of 'quality product at low list and long discount' has fully justified itself. That is the 'developments in the talking machine field in 1922 as I have observed them' which you ask me to comment on.

"I wonder if anybody has ever taken the trouble to give proper credit to The Talking Machine World for its share in developing the present very healthy situation in the industry? I think you are entitled to it, and I want to start it, or join in such an appreciation if it has already been expressed by somebody else."

P. T. CLAY VISITS VICTOR PLANT

Philip T. Clay, of Sherman, Clay & Co., San Francisco, the prominent Victor wholesalers and music merchants in the Pacific Coast territory, spent the day at the Victor factory at Camden on January 5.

THE MARKET'S BEST MERCHANDISE VALUE

THE SWANSON PORTABLE

Jobbers:—

Give the Swanson the acid test of actual comparison. If it does not prove a revelation in all the essentials of a perfect portable, return to us at our expense. Several desirable territories still open.

Weight—15¼ lbs., including album.

Size—11½x13½x7½ inches.

Tone—Natural and sonorous because of wood tone-arm and unique sounding board.



PERFECT and PORTABLE

Dealers:—

Write to-day to us or nearest jobber for full particulars.

SWANSON JOBBERS

Munson-Rayner Corporation, Los Angeles.
G. F. Johnson Piano Co., Portland, Ore.
Seattle Hardware Co., Seattle, Wash.
Tull & Gibbs, Inc., Spokane, Wash.
Z. C. M. I., Salt Lake City, Utah.
Edw. G. Hoch Co., Minneapolis, Minn.
Chas. J. Orth, Inc., Milwaukee, Wis.
Cabinet & Accessories Co., New York
Bush & Dowdell, Toronto, Canada.

SWANSON PORTABLE PHONOGRAPH DISTRIBUTORS

738 So. Los Angeles Street
Los Angeles, California

NEW LINE OF VOCALIONS ANNOUNCED BY AEOLIAN CO.

Five Conventional Styles, Two Art Models and Eight Period Consoles of Artistic Design and Ranging in Price from \$125 to \$550 Now Offered to the Trade

Under date of January 10 the Aeolian Co. made formal announcement of its line of Vocalion instruments for 1923 with revised New York retail prices effective on that date. The line of conventional models includes Style 450, red mahogany, at \$125; Style 460, brown mahogany, duo-tone, at \$135; Style 650, red and brown mahogany, at \$160; Style 550, red and brown mahogany, at \$175, and Style 720, same finish, at \$250.

The line includes two art models of particularly attractive design, namely, No. 1617, in walnut, at \$325, and No. 1627, polychrome and walnut, at \$375.

Eight period consoles are featured in the announcement, these styles having proved partic-

ularly successful during the past year. The new line includes No. 1640 at \$175 and 1642 at \$225, both finished in brown mahogany; No. 1620 at \$275, finished in brown mahogany, duo-tone; Nos. 1634 at \$350 and 1624 at \$400, both finished in walnut; No. 1628, finished in polychrome and walnut, at \$450, and No. 1632, in brown mahogany, at \$550.

All the instruments listed are equipped with the Graduola tone control, which has always been a feature of the better types of Vocalion instruments, and it is expected that the new line will find a strong demand with the discerning trade during the year. With the announcement of new styles all other models have been discontinued from the catalog.

ZIMMERMAN-BITTER CO. BUSY

Made Many Installations of Fine Store Equipment During Past Year—New Orders on Books Will Keep Plant Busy

The Zimmerman-Bitter Construction Co., manufacturer of store equipment, New York, has just closed its first year's business in a highly satisfactory manner. Its plant is now working to capacity taking care of new store equipment which it is planned to install some time this month. Among the new stores recently equipped by the company is the Rialto Phonograph Shop, 48 Delancey street, New York, where the installation consisted of seven private hearing rooms, record counters and show window, all executed in French period design. Another important contract secured by the company is for the complete equipment of the new store recently opened by Arthur Fields, popular record artist, at 2094 Seventh avenue, in the Hotel Theresa.

The company has just completed the last part of the installation of the large store recently taken over by the Sterling Piano Co. in Brooklyn. The company recently completely equipped the first two floors of the Sterling building with record booths and counters, etc., and last week saw the completion of the remaining upper floors, finishing one of the largest contracts yet secured by the company.

EILERS STOCK ORDERED SOLD

Receiver for Oregon Eilers Music House Ordered by Referee in Bankruptcy to Dispose of All Stock on Hand—Grand Juries Take Action

PORTLAND, ORE., January 6.—The referee in bankruptcy, A. M. Cannon, has ordered the receiver of Oregon Eilers Music House, S. J. Bishoff, to proceed at once and sell the entire stock of pianos, phonographs, records, band instruments and music of the firm. Hy J. Eilers, head of the firm, is out of the city.

Federal Judge Wolverton, acting upon the petition of twenty-nine creditors, declined to stop the receiver's sale which is now under way, declaring that he would not conserve the action of A. M. Cannon, referee in bankruptcy, who ordered the disposal of the stock.

The petitioners were represented by C. M. Hodges, who set forth that the combined claims of his clients totaled \$40,000, whereas the creditors who forced the concern into bankruptcy were but six in number, with combined claims of only a trifle over \$500. The sale is under the receivership of these creditors.

The Eilers case took on a new turn to-day when Hy J. Eilers, president of the defunct house, was made subject to grand jury action in two Coast States. Eilers, for many years a Portland figure, is said to be in New York. A true bill was voted against him by a San Francisco grand jury recently on a charge of conspiracy in the circulation of spurious checks bearing his signature.

District Attorney Stanley Meyers, of Mult-

nomah County, said to-day that "several local matters" involving both Eilers and worthless

checks will be placed before the Multnomah Grand Jury.

The accusation behind the offense charged to Eilers is that, before his financial difficulties led creditors to file an involuntary bankruptcy petition against him, he arranged with an employe to take a trip and cash as many checks as possible during its course.

INTRODUCE THE DANCETONE

A new Reflexo product has just been announced by Reflexo Products, Inc. It is an extra loud Gilt Edge needle, termed the Dancetone. It is expected that this new addition to the Reflexo line will rapidly gain the same amount of popularity and prestige that marks the other numbers. The Gilt Edge Dancetone needle is made by the W. H. Bagshaw Co., of Lowell, Mass., and is produced in response to a decided demand upon the part of the talking machine trade. An energetic campaign has been placed behind it by Reflexo Products, Inc., selling agent.



**Superb
Tone-Quality**

You'll get far more enjoyment from the Radio with a Music Master. And you can invite your friends to share that enjoyment and be sure of perfect results. Let your dealer demonstrate the MUSIC MASTER to you today! It will amaze and delight you!

14 inch aperture (Home model) \$30
21 inch (Concert, Dancing, etc.) \$35.

Complete, ready to attach in place of headphones. No tubes or batteries required.

Radio apparatus and parts bearing the GERACO trade-mark are thoroughly tested and guaranteed. Write for descriptive literature.

JOBBER DEALERS A music master will be sent to members of the trade with full privilege of return.

Complete details and trade-prices on request.

GENERAL RADIO CORPORATION
Makers and Distributors of High-Grade Radio Apparatus
WALTER L ECKHARDT, PRESIDENT
624-628 MARKET STREET, PHILADELPHIA 806 PENN AVENUE, PITTSBURGH

Geraco Phonograph Attachment converts your Victrola or Columbia into an efficient loud-speaker. Complete\$10.00



Distributors for OKEH Records and STRAND Phonographs and GOLD SEAL Record-Repeaters.

Sheet Music

Attracts Trade
Sells Itself
No Trouble
Small Space
No Extra Clerks
Does Not Interfere With Other Lines
Is a Desirable Adjunct
And It Pays—Liberally.

The Music Publishers' Protective Association is here showing two desirable methods of displaying sheet music, simple in design but attractive enough for the most elaborate store. The counter display case on the left is a single unit; on the right are shown two units and a display counter. It is possible to start a sheet music business with the single unit and as your department grows add to it. In this manner, on a very small investment, the retailer is enabled to display all of the numbers in sheet music form in a monthly record list. The accompanying display cases and counter are manufactured by the Unit Construction Co., of Philadelphia, Pa., which makes deliveries of the units in any finish desired to match the store interior, and with or without an electric reflector.



Single Unit Display Case



Two Display Cases With Counter

FREE!!!

**Our Cooperation
Just Fill the Blank**

To E. C. MILLS, Music Publishers Protective Association, 56 West 45th St., New York City

City

State

Street Address

Name of Store

Name of Manager

Do You Handle
Sheet Music Now?.....

Would You Be Interested
If Shown to Be Profitable?.....

GLEANINGS *from the* WORLD *of* MUSIC

SOME NOTABLE WINDOW DISPLAYS OF FEIST SONG HIT

"Three o'Clock in the Morning" Featured in Most Elaborate Manner in Window Displays by Dealers in Recent Campaign—Those Displays Selected as the Most Original and Best

During the exploitation campaign conducted during the month of November by Leo Feist, Inc., in which the successful waltz, "Three o'Clock in the Morning," was featured in advertisements in forty-two newspapers throughout the country, the entire trade showed exceptional

of these attractive window dressings that it was decided to appoint a committee of competent judges and award twenty-five prizes to the most attractive of these displays. Under the chairmanship of Carl Kaufman, treasurer of the Federal Advertising Agency, Inc., seven judges

follows, seems advisable in order to do full justice to the display:

"Placed in window is a large mantel clock, mahogany finish, with gold hands and figures. Face of clock is made of scrim or netting allowing a view inside the clock. Size of clock: Height eight feet, width fourteen feet, depth six feet six inches. Interior of clock lined with blue plush and illuminated. Looking through the scrim dial to interior one sees at back center a Style 210 Victrola, a picture of John McCormack hanging above Victrola. At left a large basket filled with roses; each rose is illuminated with a small tinted light globe placed in the center of flower. On the right side there are two very lifelike figures, four feet high, of a man and woman in waltz position. These figures are suspended from the top of the clock by an invisible string and by air currents made from invisible electric fans these figures are made to waltz back and forth, turning and reversing very naturally, and fortunately they seem to keep in perfect time with the waltz, "Three o'Clock in the Morning," being played through a Magnavox placed outside of the building above the door."

The second award was given to the S. S. Kresge store at 1449 Woodward avenue, Detroit, Mich.; third to G. Schirmer Music Stores, Inc., and Starr Piano Co., 630 South Hill street, Los Angeles, Cal.; fourth to the Strong Piano Co., Grand Junction, Colo.; also twenty-five other awards to the following: C. C. Baker, Columbus, O.; S. S. Kresge Co., Cleveland, O.; Cleveland's Music House, Beloit, Wis.; Brunswick Music Shop, Chicago, Ill.; George T. Williams, Peckville, Pa.; W. T. Grant Co., Holyoke, Mass.; Weber Jewelry & Music Co., St. Cloud, Minn.; S. E. Philpitt, Jacksonville, Fla.; The Music Shop, Kalamazoo, Mich.; Grinnell Bros., Jackson, Mich.; Sherman, Clay & Co., Seattle, Wash.; S. S. Kresge Co., 1131 Main street, Kansas City, Mo.; Sherman, Clay & Co., San Francisco, Cal.; S. S. Kresge Co., Newark, O.; Queen Weaver, Lowell, Ind.; Liberty Music Shop, Seattle, Wash.; R. Montalvo, Jr., Plainfield, N. J.; United Talking Machine Co., Willimantic, Conn.; S. S. Kresge Co., 10 South State street, Chicago, Ill.; S. S. Kresge Co.,

(Continued on page 132)

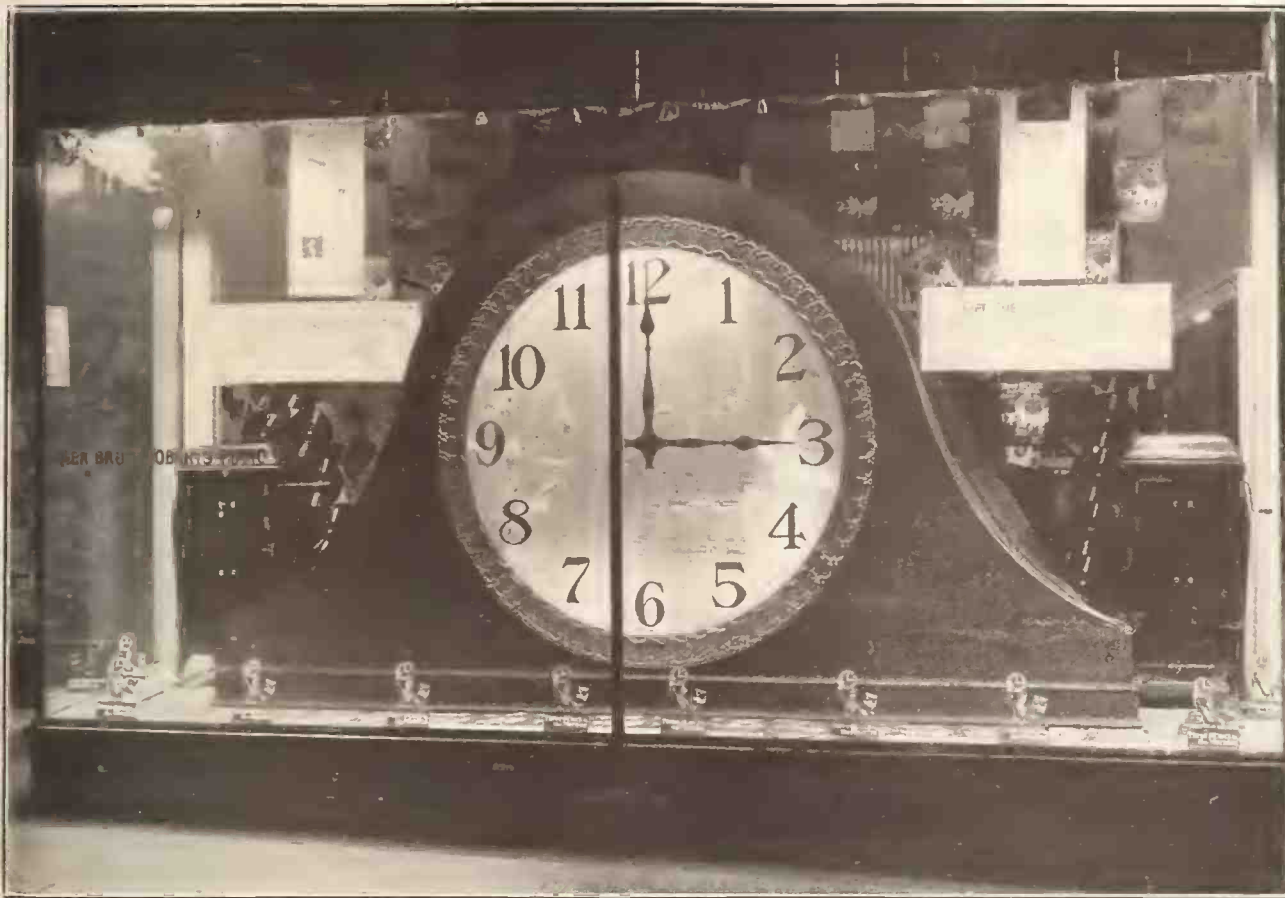

Best Display—Made by Glen Bros.-Roberts Piano Co., Salt Lake City, Utah

co-operation with the publisher. Some hundreds of dealers made exclusive window displays showing the title pages in an atmosphere that was in most cases quite original.

were appointed to pass upon the merits of the showings. The first award was made to Glen Bros.-Roberts Piano Co., Salt Lake City, Utah. A reproduction of the window is shown herewith.

The publisher received so many photographs

A minute description of this window, which

4 Reasons for "MARTHA" being a big hit ~

1.

A simple melody-beautifully arranged-combined with a consistent lyric.

2.

Hundreds of acts and singers being constantly added to great throng now singing "MARTHA"

MARTHA

3.

Now being played by every orchestra in the country.

4.

The best singing fox-trot now before the public.

READY SOON FOR ALL TALKING MACHINES ORDER NOW

PUBLISHED BY J.W. JENKINS SONS MUSIC CO. KANSAS CITY, MO

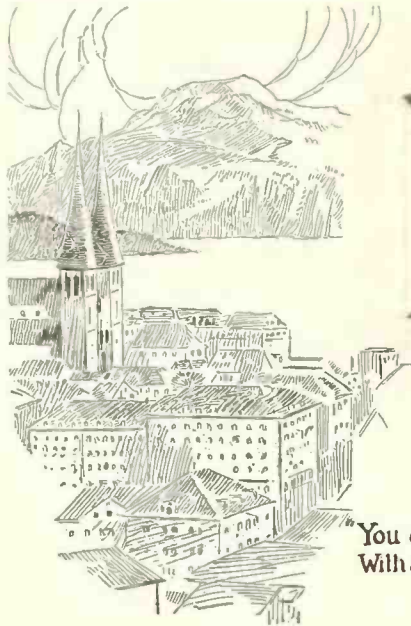

LONDON'S NEWEST WALTZ HIT! LOVELY LUCERNE

As Beautiful as "Valse Septembre" and by the same Writer



When falls the calm of e-ven-tide, There comes a vis-ion glow-ing,—

"You can't go wrong
With any FEIST song"

FINE DISPLAYS OF FEIST SONG HIT (Continued from page 131)

Toledo, O.; M. H. Housel & Co., Williamsport, Pa.; Clark-Jones-Sheeley Co., Morristown, Tenn.; W. T. Grant Co., Huntington, W. Va.; L. W. Muir, Norton, Kan.; Bluebird Music Shop, 6020 Landsdowne avenue, Philadelphia, Pa.

In the Federal Advertising Co.'s report on the displays the following comment was made:

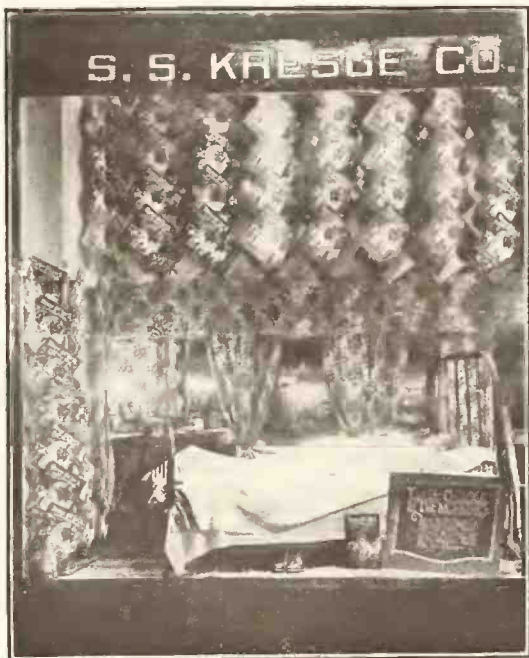

Second-best Display—Made by S. S. Kresge Co., Detroit, Mich.

"We have never seen so many excellent window trims in a single competition and it is only after most careful and reiterated study that we render judgment. We regret that there were not more prizes because there still remain a number of windows which deserve rewards and are only denied them because of the unusual quality of the other windows. We hope our



Third-best Display—Made by G. Schirmer Music Stores, Inc., and Starr Piano Co., Los Angeles

decision will meet with the endorsement of both you and those who submitted windows."

NEW BERLIN DEALER SERVICE

Irving Berlin, Inc., Concludes Arrangements for Supplying Dealers With Pictorial News Service—Many Dealers Have Signed Up

Irving Berlin, Inc., recently closed arrangements whereby for a period of one year it will place in the hands of retailers throughout the country "News of the World in Pictures." This will be known as "The Irving Berlin, Inc., Pictorial News Service" and the events of the day in the form of reproduced photographs will be forwarded gratis to any dealer interested.

Upon receipt of the material at weekly intervals it is attached to the outside of the store window where such current news immediately attracts the attention of passers-by. Undoubtedly, this service will draw customers to, and popularize, the store.

A window poster which was forwarded late in December showed the departure of Georges Clemenceau for France. The January and other posters will be of the same caliber of news quality and cover subjects of both national and international importance.

It is understood that the contract by which the Berlin organization secured the rights for this news service exclusively for the music dealers involved considerable expense. It is an effective form of advertising and has a value alike to the publisher, dealer and to the general



Fourth-best Display—Made by Strong Piano Co., Grand Junction, Col.

public, for nothing attracts attention to the window quicker than the illustration of some event of interest occurring at home or abroad.

Many dealers have already arranged for this service and as there is no cost involved, undoubtedly a large percentage of the trade will arrange for securing this material each week. This plan of attracting attention to the window makes attractive window displays more effective than would otherwise be the case.

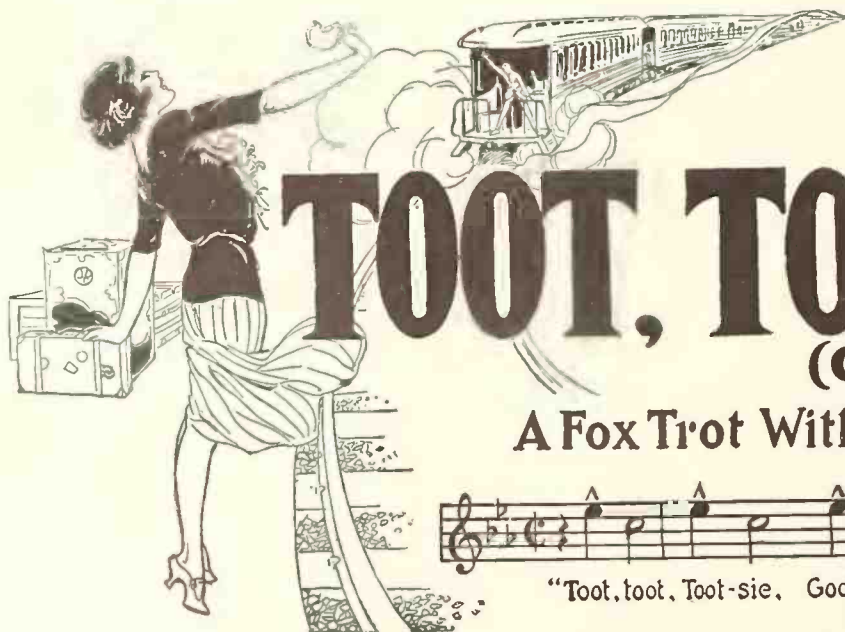

Sung by AL JOLSON in
"BOMBO."

"You can't go wrong
With any FEIST song"

TOOT, TOOT, TOOTSIE (GOO' BYE)

A Fox Trot With a Tootsie Wootsie Rhythm



"Toot, toot, Toot-sie, Goo' Bye! ———"

Toot, toot, Toot-sie, don't cry, ———"

ONE NIGHT IN JUNE

Ted Snyder's Newest Sensation

WATERSON, BERLIN & SNYDER CO.
STRAND THEATRE BLDG. - NEW YORK

FEATURE WALTZ HIT IN WINDOW

Lyon & Healy Arrange Attractive Display of "Three o'Clock in the Morning"—Sales of Records and Sheet Music Boosted

No song in recent years has received more window displays from retailers than has "Three o'Clock in the Morning," from the catalog of Leo Feist, Inc. The fact that it has been popular for an exceptionally long period has made it possible for practically the entire trade to feature it in the above manner.

Under the circumstances, then, it was most appropriate for Lyon & Healy, Chicago, Ill., who have long been known for their artistic and attractive windows, to set aside such space for a showing on this

popular number. The display in question appeared some months ago and featured the Victor Talking Machine Co.'s record of "Three o'Clock in the Morning" and several of the title pages of the number. The records were shown off advantageously on stands and the title pages were set off in a manner that made them appear as being inlaid in the dance floor; cutouts of two youthful figures dancing to the strains from a Victrola, with an antique clock in an alcove, hand pointing to three o'clock, completed the picture. The display won universal commendation.



Lyon & Healy's Attractive Display of Feist Hit

S. L. ROTHAFEL STAGES NOVELTY

Music Director of Capitol Theatre, New York, Presents Conception of the Jack Mills, Inc., Musical Success, "Kitten on the Keys"

S. L. Rothafel, director of music and presentations at the Capitol Theatre, New York, recently staged a clever conception of the musical suc-

cess, "Kitten on the Keys." A huge piano was especially constructed for the scene and two members of the Capitol ballet, costumed as kittens, did a clever interpretive dance to orchestra accompaniment. The success of this novelty was so decided that Mr. Rothafel repeated the presentation during Christmas week. Jack Mills, Inc., publishes "Kitten on the Keys."

Maurice Abrahams, formerly professional manager for Waterson, Berlin & Snyder, has opened publishing offices at 1591 Broadway, New York City.

COLLABORATE ON SONGS FOR "ELSIE"

Carlo and Sanders Combine Forces With Sissle and Blake on Score for New Show

Carlo and Sanders, writers of the song hits in the successful musical comedy, "Tangerine," have written, in collaboration with Sissle and Blake, the score for the new show called "Elsie," scheduled for its New York premiere at an early date. The Carlo and Sanders numbers are published by Jerome H. Remick & Co., Inc., and most prominent among these are: "Honeymoon Home," "Two Lips Are Roses," "Elsie," "I'll Find the Key to Your Heart," "Clouds of Love," "One Day in May" and "Glow Worm." Following its appearances in Cincinnati, O., the "Elsie" show is receiving its finishing touches in Dayton and Minneapolis, following which it will make its metropolitan bow.

Of particular importance are the songs "Honeymoon Home," "Two Lips Are Roses" and "One Day in May." The Sissle and Blake numbers are published by M. Witmark & Sons.

"MARTHA," A NEW FOX-TROT

J. W. Jenkins' Sons Music Co. Featuring New Number in a Big Way

J. W. Jenkins' Sons Music Co., Kansas City, Mo., recently introduced a new fox-trot entitled "Martha." The number is already having a heavy sale and the Jenkins organization expects it to equal in popularity anything that company has heretofore published. "Martha" combines a simple melody, well arranged with a consistent lyric. It is sung by a great number of vaudeville performers and has been played in fox-trot form by a large number of orchestra leaders. The fact that it is exceptionally popular in song form will do much to increase its popularity and add to its sales.



I GAVE YOU UP JUST BEFORE YOU THREW ME DOWN



Being played and sung everywhere
Released soon on all records and rolls

WATERSON, BERLIN & SNYDER CO.
STRAND THEATRE BLDG NEW YORK



I'm Just a Little Blue for you

Waltz Ballad
by EGBERT VAN ALSTYNE & HAVEN GILLESPIE

Egbert Van Alstyne's name on a song is the sign of a Sure-fire Hit.



JEROME H. REMICK & CO. NEW YORK · CHICAGO · DETROIT

TENDENCY TO CRITICIZE MUSIC OF MODERN COMPOSERS

Alfred Walker Shows That the Appropriation of Standard Classical Numbers, Which Are Given a Modern Musical Dress, Has Ever Existed, for Music Is a Living, Growing Art

Some months back there was a tendency on the part of those who value personal newspaper publicity to get their quota of space by denouncing modern music and terming it jazz. The tide in that direction evidently has turned; probably the newspaper editors felt that their subscribers had been surfeited with such material and that there was no longer a response. At any rate, in recent weeks, there have come to the defense of modern music many people of importance, musicians and singers of note, critics and authorities. It must be said for these latter that their messages are of the constructive kind, are thoughtful, based upon knowledge and in time should prove of value.

The old method of denouncing all modern music as jazz, crying loudly for its elimination and not offering anything substantial to take its place, spent itself through its very inability to form a substantial foundation upon which what is termed better music could be built.

Many propagandists against modern music would have the nation return to the folk songs of the type prevalent in Europe in past years and which, no doubt, are to-day still a factor in community life in some sections. They forget, however, that folk songs were, and are, songs of a particular period to meet the needs of the life of their time and are of value because they are inspired by such need.

Naturally, in America, we cannot go back to the far periods possible in Europe. There is, however, in America proof of the reason and value and the very necessity of songs of the folk type, such as our negro melodies and the lighter melodies of some of our mountain country and the popular songs of the old West.

In this mechanical age it is practically im-

possible for folk songs to have the attraction that it was possible for them to achieve in days gone by. The community life of older cities, which was part farm, part shopkeepers and part land owners of better class, practically is no more. To-day the life of the cities in working hours is given over mostly to manufacture and the necessary business adjuncts. The cities themselves are congested and the larger of them get their community life from the movies. Invariably they do not know their next-door neighbors, but they all know Constance Talmadge, the movie star.

Modern music, therefore, is a response to the demand of the present day. It is not probably as picturesque or as romantic as folk songs of long ago, but it is filling the need and filling it in a modern way. There is room for improvement, but this cannot be forced and we cannot return to that which is passé.

The following letter to the editor of the New York Times was recently written by Alfred Walker, who is a well-trained musician, and it carries a message worthy of consideration:

"Richard Aldrich in last Sunday's Times deplores the tendency of topical songwriters to 'jazz' the melodies of the masters. Mr. Aldrich should not despair, for 'twas ever thus. The dishing up of a melody to please the taste of the day always has been, is, and always will be, done while a taste for things exists.

"Dr. Hubert Parry shows how the old Hungarian folk songs were thus changed and decorated by the gypsy fiddlers. Joseph Haydn and even Beethoven, to say nothing of Brahms and Liszt, used the methods of those same Hungarian gypsies. Bach and Handel both took popular melodies of their day and embodied them in their works in the manner of

their day. "When I was a student at the Royal Academy of Music in London in the 70's there were piano teachers who had objected to Robert Schumann's music but a few years before.

"Music is a living, growing art, constantly developing. These jazz people are just trying for new methods of expression. Their doings are necessarily crude and often rather coarse, but so are the outer fringes of any other art.

"China tried to limit music to five tones (was it during the Ming dynasty?) and we smile at the crudities of Chinese music. Music cannot rise higher than its source, which is the popular taste of the day.

"Far worse than jazz, to me, is this mawkish sentimentality of these solo violinists. What a contrast to the vitality and splendid spontaneity of Joseph Joachim and men of his day!"

IRVING BERLIN, INC., BUYS "IVY"

Plan to Feature Number in a Big Way—Already Popular in the West

Some weeks back the scouts of the Irving Berlin organization discovered that there was quite popular in Chicago a song called "Ivy" (Cling to Me). Negotiations for the purchase of the number were immediately and successfully carried out and the result is that Irving Berlin, Inc., has added this song to its catalog. During the month of January the professional and band and orchestra departments of the Berlin organization will feature this number in addition to the acknowledged successes of the catalog, "Homesick" and "Open Up Your Arms" (My Alabama).

Paul Whiteman, in collaboration with Marshall Neilan and Ferdy Grofe, has written a new song entitled "Wonderful One." It is of the waltz variety and was originally introduced at the Trianon in Chicago.

DOWN IN MARYLAND

Another Wonderful Song by the writers of "My Sunny Tennessee"

WATERSON, BERLIN & SNYDER CO.
STRAND THEATRE BLDG. NEW YORK

THE NEW DANCE SENSATION

FATE

ORIENTAL FOX TROT

PLAYED WITH GREAT SUCCESS BY **TED LEWIS** in **THE GREENWICH VILLAGE FOLLIES**



M. WITMARK & SONS - Publishers - Witmark Building - NEW YORK

PREDICT LONG RUN FOR "GLORY"

Leo Feist, Inc., Publisher of Songs for Latest Musical Comedy

Harry Tierney and Joseph McCarthy now have two successes playing on Broadway. Several weeks back the William A. Brady production, "Up She Goes," had an auspicious opening and early this month a new musical comedy, "Glory," with music by the same writers, opened at the Vanderbilt Theatre.

That "Glory" will remain for many months

is apparently undisputed. All of the New York critics predict a long run for the show. The New York Times says: "The play is very pleasing in the development of the plot and somewhat novel. The score is one of the prettiest heard on Broadway in a long time and it maintains its excellence throughout. And the songs spring naturally from the score and the plot. They are not thrown in for the hit they may make."

The book of "Glory" is by James Montgomery, who is also the author of "Irene," and undoubtedly it will be as popular as its predecessor.

Among the songs that have been mentioned as meriting attention are: "The Saw Mill River Road," "Mother's Wedding Dress," "We've Got to Build," "Post Office," "When Curfew Rings at Nine" and "The Little White House." Leo Feist, Inc., is the publisher.

DRESSER TO LIE BESIDE WABASH

Remains of Noted Composer to Be Moved to Sepulchre in a Memorial Park on the Banks of the River He Made Famous in Song

CHICAGO, ILL., January 2.—Beneath the sycamores along the stream he helped to immortalize, Paul Dresser, who wrote the song, "On the Banks of the Wabash," will sleep forever, the Indiana Society of Chicago has announced.

Gov. McCray, of Indiana, the announcement said, has received the consent of five brothers and sisters of the poet to the removal of the body from the grave in Chicago to some spot on the banks of the Wabash River.

Proposals have come from both Lafayette and Terre Haute that the sepulchre be erected in a memorial park which each of the cities seeks to build.

MUSIC MEANS SHOW'S SUCCESS

Several Numbers in "Music Box Revue" That Have Won Unusual Favor

The fact that the new Irving Berlin "Music Box Revue" has been playing in New York for a number of weeks has aided in demonstrating that the songs of the show are as popular as predicted by various members of the Berlin organization. Last season's "Music Box Revue" had only two or three outstanding successes, but despite that the show was quite popular and this has been credited to the fact that it was extravagantly staged, quite spectacular and included a clever cast. This season's "Music Box Revue," however, is succeeding in attracting crowds to a great extent by the merit of the songs in the show. It is not lacking in other features, but the musical numbers are the predominating factors. Among the songs that merit attention are: "Crinoline Days," "Lady of the Evening," "Will She Come From the East?" "Pack Up Your Sins" (And Go to the Devil), "Porcelain Maid," "The Little Red Iacquer Cage" and "Bring on the Pepper."

ITALIAN COMPOSER IRRESPONSIBLE

ROME, ITALY, December 30.—Maestro Lorenzo Perosi, Italy's greatest composer of sacred music and formerly in charge of the Sistine Chapel Choir, has been declared mentally irresponsible.

This action was taken to save his precious compositions which he refused to give to publishers, insisting that they would alter them. An art and medical commission made the decision declaring him irresponsible.



Concentration Drive
ON
ROMANY LOVE
From January 15th to 27th inclusive

Let's Get Together!—

We don't have to tell you that when we ALL work toward a single purpose we can obtain maximum results. And, that's the idea of this CONCENTRATED DRIVE on "Romany Love," when we are going to hit old man "public" from all sides.

If you are—an Orchestra or Band Leader; an Organist or Singer; a Sheet Music Dealer or Jobber; a Record or Music Roll Dealer or Jobber—or in any other position whereby you can hook up with us, "get set" for the big drive now and feature in some way "Romany Love."

Musicians who may have mislaid copies can secure another at once. Extra title pages and display material are available for the dealers and we urge that the dealers display the sheet music, records and rolls—"kill three birds with one stone."

LET'S HELP EACH OTHER!

REMEMBER THE DATE—JANUARY 15th to 27th
SAM FOX PUBLISHING CO., Cleveland, O., U. S. A.

The Waltz Hit for 1923

EVERY WEDNESDAY NIGHT

WALTZ

IRVING BERLIN, Inc.

1607 Broadway, New York City

WITMARK & SONS GET NICE CATALOG

Will Control Sales of Various Numbers Published by B. D. Nice & Co.

M. Witmark & Sons have acquired the catalog of songs formerly published by B. D. Nice & Co., Inc., and in the future will control the sales of the various numbers bearing the imprint of that company. Lee David, who was formerly closely associated with the Nice firm, is already under contract with Witmark's, they having accepted some time ago his "Where the Volga Flows," following which, a contract over a long period was arranged.

Among the numbers that now come under Witmark control are "Romance," "Paper Doll," "Tents of Arabs," "Sweet Lavender," "Wondering," "Figaro," "All My Life," "Clouds," "I Might Have Had You," "Congo Love," "Do a Little This, Do a Little That" and a new song entitled "In Our Parlor on a Sunday Night."

BROADCAST JACK SNYDER SONGS

LOS ANGELES, CAL., December 30.—The Jack Snyder songs were broadcast by radio from station KWH, this city, recently, during the stay of Jack Harris, general manager of Jack Snyder, Inc., who is exploiting the Snyder publications. He is making an auto trip from coast to coast and is expected in New York shortly. The "November Rose" and "In Maytime" sales have shown a decided increase at all points.

The song "All Muddled Up," from the catalog of Leo Feist, Inc., is the exclusive number in the drama of "The Bootleggers," now playing at the Thirty-ninth Street Theatre, New York City. The show has been quite successful and there are many indications that it will play for the balance of the season. Therefore, the above Feist number will come in for some unusual publicity over a long period.

"WITMARK BLACK AND WHITE SERIES" NOW REGISTERED

Prominent New York Publishers Announce That Official Registration Was Granted by the Patent Office of Washington, D. C., Under Date of December 12—Protection Well Merited

The announcement was made early this month by M. Witmark & Sons, the well-known publishing house, that they have been granted by the Patent Office the right to register the trade mark "Witmark Black and White Series." This familiar slogan, which for over twenty years has been identified with the highest type of melody ballads, now becomes, by authority of the Government, an exclusive national product.

The application for the registration of the "Witmark Black and White Series" was faced by what is officially known as "interference," the opposition originating from a chemical manufacturing concern located in the South and another concern doing business in Cincinnati,

O., both of whom claim the right to use "Black and White" as a trade mark. One of the contestants subsequently joined M. Witmark & Sons in protecting the latter's rights in the matter. Counsel in Washington was engaged and after several delays the case came up for adjudication before the Patent Office, with the result that the application for the trade mark was allowed by the officials of the Patent Office at Washington, D. C., on December 12, 1922, in favor of the "Witmark Black and White" publications, all of which will be of importance to the trade, and, no doubt, gratifying to the industry. This establishes the Witmark right to the trade-mark.

A STRONG W., B. & S. BALLAD

Waterson, Berlin & Snyder are the publishers of a ballad that is not only having exceptional popularity as a song, but is a strong feature in many dance programs. It is entitled "I Gave You Up Just Before You Threw Me Down." This, together with "Haunting Blues" and "Tomorrow," is the feature number of this season's catalog. The various Waterson, Berlin & Snyder branches, as well as the professional and band and orchestra departments, are campaigning on all of the above songs with the greatest success.

Among the new songs recently added to the catalog of Waterson, Berlin & Snyder is a ballad entitled "Down in Maryland," the work of Bert Kalmar and Harry Ruby, and a novelty entitled "Aggravatin' Papa," by Roy Turk and J. Russel Robinson. "Down in Maryland," "One Night in June" and "The Lovelight in Your Eyes" are also new additions.

LEO FEIST'S GIFT TO ACTORS' FUND

In commemoration of the twenty-fifth anniversary of the establishment of Leo Feist, Inc., Mr. Feist recently donated \$5,000 to the Actors' Fund. The only stipulation with the gift was that an equal amount be raised in a drive. The latter program has been carried out by the New York Clipper. Mr. Feist has always taken a decided interest in the activities of actors and his business being closely allied to that profession, he felt the urge to do something substantial for the fund.

E. C. Mills, chairman of the executive board of the Music Publishers' Protective Association, was recently appointed receiver for the Harry Von Tilzer Music Publishing Co. Earlier in the month he was appointed co-receiver for the Broadway Music Corp. These two new activities added to his already voluminous Association work have given him a new distinction and title, "E. C. Mills, the Well-known Receiver."

THE LOVELIGHT
IN YOUR EYES*A Beautiful Fox Trot Ballad*WATERSON, BERLIN & SNYDER CO.
STRAND THEATRE BLDG. NEW YORK

THE MOST SENSATIONAL FOX-TROT EVER WRITTEN

IVY

CLING TO ME

Soon to be Released by all Mechanical Companies

IRVING BERLIN, Inc. 1607 Broadway, New York City

JUILLIARD MILLIONS AID MUSIC

Musical Foundation Has Begun to Function— Trustees Pick Beneficiaries From Thousands of Applicants From All Parts of Country

The Juilliard Musical Foundation, described as the fairy godfather of American music and musicians, has begun to function, it was learned recently, when it became known that a number of aspiring students of music had been chosen for the free musical education which was the design of the late Augustus D. Juilliard, who left between \$12,000,000 and \$15,000,000 to found the fund. Dr. Eugene A. Noble, executive secretary of the foundation, said, however, that such an ambitious scheme required a great deal of planning and that the doors were not yet open for all who desired to avail themselves of the fund.

Protracted litigation by heirs of Mr. Juilliard, it was pointed out, had held back the carrying out of the wishes of the founder. It was said that about \$7,000,000 was now in process of investment for the foundation's plans and that eventually about \$400,000 a year would be at the disposal of the trustees.

In selecting young students as beneficiaries of the Juilliard will, about 4,000 applicants have so far been sifted. These resided throughout the country, and to test their qualifications volunteer committees served, reporting their verdicts to the Foundation's headquarters in the Guaranty Trust Building, Fifth avenue and Forty-fourth street.

Emery's Music House, 430 Locust street, Columbia, Pa., recently moved into its new home in the Harlem Building, 438 Locust street. Edison phonographs and Columbia Grafonolas are handled, as well as a very complete stock of records.

FINE MUSICAL NUMBERS IN "ELSIE"

M. Witmark & Son Are the Publishers of Songs for New Musical Comedy

A new musical comedy called "Elsie," produced by John Scholl, had its premiere in Cincinnati, O., recently and will, after playing in a number of other cities, have a New York presentation. The piece is said to be quite novel and is well staged, particularly the dances. The musical numbers are from the pens of Noble Sissle and Eubie Blake, who were responsible for the long New York run of "Shuffle Along." There are eight songs in all—"I Like to Walk With a Pal Like You," "Elsie," "Jazzing Thunderstorm," "Jingle Step," "A Regular Guy," "Sand Flowers," "Two Hearts in Tune" and "With You." The numbers are published by M. Witmark & Sons, who were also the publishers of the music of "Shuffle Along." We have had "Sally," "Irene" and "Mary," all of them big successes. It remains to be seen whether "Elsie" can repeat the successes of other shows dedicated to the names of girls. Whether or not it does its appearance is expectantly awaited on Broadway.

WILL HAVE GOTHAM REPRESENTATIVE

Following the visit to New York of E. Grant Ege, head of the music publishing department of J. W. Jenkins' Sons Music Co., it is understood that immediately upon his return to his desk he will make arrangements to keep a permanent representative in New York City. The success of the new song, "Martha," has made this necessary, particularly as the Eastern jobbers report it among the most active sellers of this season. This move will add greatly to the efficiency of the J. W. Jenkins' Sons Music Co. service in the East.

MODERN DANCE MUSIC ON THE STAGE

Growing Tendency Favoring Dance Music Evident in Recent Dramatic Productions

In recent weeks, with the staging of several legitimate dramas, there has been a tendency to recognize the modern dance music. From indications no show seems complete without music upon the stage. The latest production to recognize dance music is Al Wood's "The Masked Woman," wherein appears a pianist who renders appropriately and effectively several dance numbers during the ballroom scene of the play. The following melodies are played nightly: "The Pelican," a fox-trot; "Love's Lament," a waltz; "No Use Crying," a fox-trot, and "Joy, Joy, Joy," a fox-trot one-step. The Edward B. Marks Music Co. is the publisher of the above numbers.

MAURICE RICHMOND BACK AT WORK

Head of the Richmond Music Supply Corp. Hale and Hearty After Breakdown

The trade is well aware that Maurice Richmond, head of the Richmond Music Supply Corp., found it necessary, as a result of a breakdown in health, to spend many months of last year away from his office. It was, therefore, somewhat surprising to see him back at his desk in his old-time form, showing no traces of the experiences which resulted in keeping him away from business. Mr. Richmond credits his renewed condition and vigor to one Bill Brown, whom he calls "The Miracle Man," and he is anxious that every one in the trade who finds it necessary to take a week or two of rest should be acquainted with this "Miracle Man," who operates what is known as Brownsdale, at Garrison-on-the-Hudson.



Fall - ing in love, yes fall - ing Fall - ing in love with you

FALLING

A Fascinating Ballad Fox Trot

JEROME H. REMICK & CO.
NEW YORK • CHICAGO • DETROIT

A HOT TUNE

NUTHIN' BUT

BY THE WRITER OF "HOT LIPS"

Being Featured by all Orchestras from Coast to Coast

IRVING BERLIN, Inc.

1607 Broadway, New York City

NEW MUSICAL COMBINE EFFECTED

Combination of Musical Bureaus Expected to Have Wide Influence on Concert Industry

By the terms of an agreement entered into recently by and between the Wolfsohn Musical Bureau and the Music League of America, Inc., and Concert Management Arthur Judson and the Associated Musical Bureaus of America, Inc., a combination has been effected which is destined to exert a constructive influence of the widest possible character on the concert-giving industry of the United States and Canada.

Under this agreement (which concentrates and solidifies the recent combination of Concert Management Arthur Judson and the Associated Musical Bureaus) the Wolfsohn Musical Bureau is to have transferred and assigned to it all contracts for the engagement and management of artists and musical attractions now under the control of the Judson management.

Thus, in effect, the Wolfsohn Musical Bureau will "produce" music artists and organizations. Save in New York, Boston, Chicago and Philadelphia (where the Wolfsohns will continue to book direct) the artists and organizations for whose services the Wolfsohn Bureau contracts will be booked through Concert Management Arthur Judson and the Associated Musical Bureaus—but always under the supervision of the Wolfsohn Bureau.

The Wolfsohn Bureau will thereby be enabled to devote itself exclusively to securing the artists it considers most suitable for concert-giving needs—excepting that it will book direct its artists in the four cities above mentioned.

The contract is for a period of ten years, with a renewal option for a similar period. The operation of the contract begins with the season of 1923-1924.

SOCIETY DECLARES NEW DIVIDEND

American Society of Composers, Authors and Publishers Has Good Royalty Year

The fourth quarterly dividend of the American Society of Composers, Authors and Publishers was declared late in December, although payment is not due until January. The payment will be approximately \$35,000, which brings royalties of the Society to over \$150,000 for the four dividends declared in 1922. \$17,500 of the above amount was given to the music publishers who are members of the organization and the balance was awarded to composers and authors.

"WISTFUL WALTZ" SALES BOOMING

The Boosey & Co. number, "Wistful Waltz," has achieved so much success in dance and song circles as to require the publishers to order it reprinted several times. In fact, its sale is becoming so voluminous that the publishers are seriously considering issuing it with an entirely new title page. Besides the many leading orchestras which have commented favorably on this waltz success, the retail sales have been so active as to encourage letters of commendation from dealers.

GUILD GIVES FIRST CONCERT

The International Composers' Guild recently gave its first concert at the Klaw Theatre, New York. The concert was well attended and received lengthy reviews from practically all of the New York papers. The Guild has for its purpose the presentation of compositions of composers who have meritorious works but who find little response from publishers to their offerings.

"NOVEMBER ROSE" POPULAR

New Waltz Ballad of Jack Snyder Catalog Featured by Concert Artists

Jack Snyder, Music Publisher, Inc., is having some unusual success with its new waltz ballad, "November Rose." The number has been frequently compared to "The Last Rose of Summer" and several concert artists have expressed themselves as favoring it to any recent issue.

The above song, together with "In May Time" (I Learned to Love) and "Meet Me Next Sunday," are the feature numbers of the Jack Snyder catalog. A publicity campaign on these three prints has been inaugurated for the early months of 1923.

MARKS MUSIC CO. PLANS FOR 1923

Publishing House to Carry Out Active Program in Popular and Standard Fields

Edward B. Marks, of the Edward B. Marks Music Co., 223 West Forty-sixth street, New York City, is quite optimistic over the plans of his company for the new year. In the popular field the Edward B. Marks Co. will give particular attention to a series of numbers to be released. In addition the successes of last year are to be featured. These include "Parade of the Wooden Soldiers," "Old Plantation Home," "Love's Lament," "Whenever You're Lonesome," "Sonja," "No Use Crying" and "Eddie Leonard Blues."

Colin O'More, well-known concert and Vocalion record artist, who has been giving a series of concerts in the metropolitan district, has been singing with great success the song, "Just a Bit of Irish Lace," one of the new additions to the catalog of Sherman, Clay & Co.



A NOVELTY
FOX TROT

By the writers of
"CANADIAN CAPERS"

HOT 'N COLD

LYRIC BY
ABE OLMAN

MUSIC BY
HENRY R. COHEN

Oh! what a tune! It's snap-ty trot, just pip-pin hot. Puts red pep-pers in-to your step-pers.

JEROME H. REMICK & CO. NEW YORK · CHICAGO · DETROIT



MILLION DOLLAR MASTER FOX-TROT MELODY

PARADE OF THE WOODEN SOLDIERS

NEW PARIS-VIENNA WALTZ

LOVE'S LAMENT

DUNCAN SISTERS FOX-TROT SENSATION

OLD APPLE TREE

STOCK IN THE ABOVE-SHEET MUSIC, RECORDS AND ROLLS, WRITE FOR SPECIAL OFFER AND COMPLETE CATALOG OF SHEET MUSIC
EDW. B. MARKS MUSIC CO. 223-25 W. 46TH ST. NEW YORK.

ANNOUNCES TWO NEW STRAND MODELS

Models 23 and 24 Now Being Shipped to the Trade—Handsome Consoles With Standard Strand Equipment Are Much Admired

The Manufacturers' Phonograph Co., New York, manufacturer of the Strand line of phonographs, has just announced two new additions to its line, designated as models 23 and 24. It had been intended originally to announce these models in February, but owing to the tremendous demand for Strand products during the holiday season Geo. W. Lyle, president of the company, asked the factory executives to ship the new instruments as quickly as possible. Quite a number of these new models were shipped to Strand dealers the latter part of December and they have met with the enthusiastic approval of the trade.

The Strand model 23, which is listed at \$115, is designed in accordance with the Heppelwhite style of the Georgian period, with low relief ornaments of bell flowers and delicate tops and rosettes. The legs are square and tapering with the spade foot. This instrument is finished in walnut and brown mahogany and measures thirty-six inches in length, twenty-one inches in depth and thirty-four inches in height. It is equipped with the heavy double spring guaranteed Strand motor, playing twenty-one minutes, all-wood tone chamber, solid brass tone arm and all of the other distinctive features forming part of Strand equipment.

This cabinet is also supplied with Strand equipment and is designated as Console 102, providing a flat top console cabinet for housing the Victrola VI.

The Strand model 24, listed at \$175, is one of the most artistic models of the Strand line and is designed after the French Chippendale period. It is an impressive instrument in two-tone finish, with ivory-colored lines dividing ebonized edges from the walnut or mahogany centers. It is finished in walnut and brown mahogany and is thirty-six inches long, twenty-one inches deep and thirty-four inches high. This instrument also has the distinctive Strand equipment that has been such an important factor in the phenomenal success of this line throughout the country.

BANKRUPTCY PETITION FILED

A petition in bankruptcy has been filed against the Union Talking Machine Co., New York City. The concern is located at 15 Avenue B, and Nathan Smith is named as the proprietor and manager.

APPOINTED MELO-TONE DISTRIBUTOR

L. D. Heater, of Portland, Ore., to Look After National Distribution of the New Melo-Tone Device—Plans Strong Trade Campaign

PORTLAND, ORE., January 4.—A. C. Sherbert, of the Melo-Tone Co., this city, manufacturers of the Melo-Tone attachment, announces that L. D. Heater, 357 Ankeny street, well-known jobber of Strand talking machines, phonograph supplies and accessories, has been appointed national distributor of their Melo-Tone device.

Both Mr. Heater and the members of the company are very enthusiastic regarding the future of the Melo-Tone and the early expectations concerning the success of the attachment were borne out recently through a circularization of the Coast trade, which netted a highly gratifying return and considerable favorable comment.

A number of the larger establishments have equipped the machines of their record demonstration rooms with Melo-Tones which, they say, have materially helped to make their more or less soundproof rooms really soundproof, as well as sending home in the evening with unjangled nerves those engaged in the selling of records.

The Melo-Tone attachment is finding a ready market among those who prefer a soft, mellow tone, rather than the loud, full volume of the instrument unmodified, and the fact that it can be instantly attached or instantly removed, together with its popular retail price, has contributed greatly to its instant and growing popularity.

DECORATED "TALKERS" POPULAR

The special decorating of phonographs grew into a decidedly popular demand during 1922, reports E. Estrin, president of the Mohawk Works of Art, New York City. Mr. Estrin has prepared a number of new designs for 1923 and believes that this special work will experience still further increase in popularity during the coming year.

VAN VEEN CO. GETS MANY ORDERS

Leon Tobias, secretary of Van Veen & Co., Inc., New York City, manufacturers of talking machine wareroom equipment, reports that although the year is still young a number of orders and requests for specifications have been received indicating a general tendency on the part of the trade to increase its selling equipment during the coming year.

JEWEL SALES DIRECTOR VISITS TRADE

A. B. Cornell Calls on Eastern Manufacturers—Company Closed Best Year in History

A. B. Cornell, treasurer and sales director of the Jewel Phonoparts Co., Chicago, was a visitor to New York last week, after spending the Christmas holidays at his farm in Somerville, N. J. Mr. Cornell called on several of the manufacturers in the city and before returning to Chicago made plans for a trip which included a visit to Boston, Philadelphia, Pittsburgh, Richmond and adjoining cities.

In a chat with The World Mr. Cornell stated that the Jewel Phonoparts Co. had closed the best year in its history and that orders on hand at the present time indicated an exceptional business for the first few months of the new year. The new tone arms recently introduced by the company have been received enthusiastically by the trade and several important contracts have been closed whereby these tone arms will be used as exclusive equipment by well-known manufacturers. The Jewel attachments for playing Edison records on other makes of machines enjoyed a remarkable sale during 1922 and under Mr. Cornell's direction an intensive publicity campaign was inaugurated during the Fall and holiday seasons which produced exceptional results.



PHONOGRAPH DE LUXE

The instrument of incomparable tone, that plays any record better than you have ever heard it played before.

Complete line of table, upright and console models.

Prices to the Trade Range from

\$8.50 to \$125.00

Cabinets of beautiful design and finish, improved motor equipment.

Dealers write us: The Reginas now in homes are making lots of friends; people come in and ask for them. Watch us increase our sales.

Cash in on the Regina; now is the time. Also Regina Music Boxes with or without phono attachment.

Regina Hexaphones and Mandolin orchestrons.

Regina tune discs and parts for any instrument ever manufactured by the Regina Co.

Send for particulars on territory arrangements.

Musical Instrument Specialty Co.

MANUFACTURERS

RAHWAY

NEW JERSEY

PHONOMOTOR PRODUCTS, PHONOSTOPS and NEEDLE CLIPPERS

ALWAYS THE BEST

PHONOMOTOR COMPANY

121 WEST AVENUE, ROCHESTER, N. Y.

Another "McCarthy-Tierney" Masterpiece!— SAWMILL RIVER ROAD

That Irresistible Fox Trot From *Glory*

You can HEAR it
and BUY it HERE

"You can't go wrong
With any 'FEIST' song"



FINE OUTLOOK FOR COLUMBIA LINE

Columbia Graphophone Co., Wholesale, Looks Forward to 1923 to Be Best Year in History —Persistence Wins in Business Race

The New York wholesale branch of the Columbia Graphophone Co., New York, reports that it has just closed one of the most prosperous years in its history. The demand for Grafonolas during October, November and December was so great as to tax every resource of the company to make delivery to its dealers throughout the large territory which it serves—one of the largest of any of the Columbia branches, as it includes Manhattan, Brooklyn, Long Island, the State of New Jersey, New York State and the greater part of Connecticut. This territory comprises a greater number of dealers, perhaps, than any served by a Columbia branch, requiring a service of the highest efficiency in order to take care of every dealer in the best possible manner.

According to Kenneth Mills, general manager of the company, and B. W. Jennings, Mr. Mills' assistant, 1923, from all indications, will be one of the best yet experienced. "Throughout the entire organization," stated Mr. Jennings, "there is a spirit of optimism that is bound to create a large volume of business and with the hearty co-operation of every one concerned we are confident that the new year will be a most prosperous one."

Although record business during the holidays was not as great as it might have been, dealers are reporting that during the past two weeks this phase of the business has shown a decided spurt. This, no doubt, is the result of the large machine business done during the holidays, which is resulting in a decided increase in record sales, enabling dealers to show a handsome profit in this department of their business.

An important phase of the business being done by Columbia dealers in this territory, according to Mr. Jennings, is their persistent efforts to place machines in the homes of the public. Dealers generally have realized the necessity of intensive efforts, and in consequence most all of them have employed many outside salesmen in developing business. Wholesale houses have urged the necessity of such methods and as a result most dealers who have been alive to the situation report a decided boost in Grafonola sales, which will help materially in putting 1922 business over the top.

There is always a substantial reason, at least to the patron, when a customer discontinues buying. It pays to find out.

EXPERT REPAIRING

of all parts and makes of phonographs
LOWEST PRICES — 24 HOUR SERVICE

Send us the article to be replaced or repaired by Parcel Post or Express

PENN PHONOGRAPH CO. of N. Y.
513 8th Avenue New York

FUTURE BRIGHT, SAYS A. H. CURRY

Vice-president of Thomas A. Edison, Inc., Optimistic Over Future Outlook

When interviewed this month by The World A. H. Curry, vice-president and manager of the phonograph division of Thomas A. Edison, Inc., spoke in a very optimistic vein regarding the outlook for the manufacturing, wholesale and retail divisions of the Edison phonograph industry. For some time past every effort has been concentrated on merchandising plans which make for a maximum rapidity and uniformity of turnover for Edison jobbers and Edison dealers and which assure this maximum turnover in each case on a minimum of inventory. That these plans are proving highly successful is evidenced by the exceedingly fine volume of business which the Edison Co. is now doing every month and the marked shortage which occurred during the holiday season which has just passed. Production is being steadily increased to meet the increased demand and there is every indication that in both the phonograph and record ends the Edison trade will be taken care of in a satisfactory manner and in a way to assure a deserved prosperity all along the line.

RADIO CONGRESS IN PHILADELPHIA

President of General Radio Corp. Will Be Host to Dealers and Jobbers Interested in Future of Radio—Meeting to Be Held in February

PHILADELPHIA, PA., January 9.—Walter Eckhardt, president of the General Radio Corp., 624 Market street, this city, has planned to hold a Radio Congress in February. At that time this well-known corporation will be host to its dealers and jobbers. Mr. Eckhardt stated that he was prompted to call this congress of engineers and experts to discuss radio developments at length with his organization because of the great possibilities of radio which he points out have become so apparent.

ADDS HALLET & DAVIS LINE

LOWELL, MASS., January 8.—The Song Shop, 127 Merrimack street, this city, which has filled a long-felt want since its opening a few months ago, is already expanding and from now on will be the local headquarters for Hallet & Davis pianos and phonographs. Among the records handled will be the Vocalion line. H. B. Leggatt is the proprietor of this growing business.

The Edison Winter tone test season has now been completed and the schedule for the Spring season is now in process of formulation.

The early bird still gets the worm (business), despite reports to the contrary.

DETROIT BRANCH WINS CONTEST

Three Columbia Branches Engage in Exciting Sales Contest—Buffalo Branch Host to Detroit and Cleveland Staffs

Geo. W. Hopkins, general sales manager of the Columbia Graphophone Co., announced this week the result of the sales contest instituted by the "Lake Erie Triple Alliance," comprising the Detroit, Cleveland and Buffalo branches of the company. This contest extended over a period of ten weeks, and at the close of 1922 the Detroit branch was declared the winner after an exciting battle. The Cleveland branch finished second, with the Buffalo branch third.

Being the loser in this contest, the Buffalo branch was the host to the staff of both the Detroit and Cleveland branches at a banquet held in Buffalo Saturday evening. R. W. Porter, field sales manager of the Columbia Co., was present and it was understood that many unique ideas of entertainment contributed to the enjoyment of the evening. H. E. Gardiner is manager of the Detroit branch, which won the contest; S. E. Larmon is manager of the Cleveland branch and H. L. Haring is manager of the Buffalo branch.

MERITORIOUS WINDOW DISPLAY

KINGSTON, N. Y., January 9.—W. S. McDonough, Columbia dealer in this city, is a firm believer in the value of attractive and distinctive window displays, and frequently his windows are mentioned in the columns of the Kingston news-



McDonough's Striking Window Display

In the accompanying photograph Mr. McDonough prepared a window display that was timely to a degree, and what is more important is the fact that it produced tangible and direct results. Incidentally the window was described in detail on the front page of the two Kingston newspapers, thus the display was a means of valuable publicity.

Alexander Steinert, of the firm of M. Steinert & Sons, Boston, Mass., has been made a member of the legal committee of the Music Industries Chamber of Commerce. He succeeds the late Kirkland H. Gibson.

WARNING!

Be sure you buy metal disc blanks having the trade mark, KODISK, the only Metal Recording disc legally protected by U. S. Patent No. 1,421,045 issued June 27, 1922. This patent covers every basic principle of sound recording on a metal disc on any phonograph and is your protection as well as our protection against unfair competition.

KODISK can be bought from our authorized distributors and every KODISK bears our registered trade mark, KODISK, and the number of our patent and the date it was issued. We will protect our rights by prosecuting all infringers. You are liable if you sell merchandise not properly protected by granted Government Patents.

**Protect Yourself From Liability to Expensive
and Troublesome Lawsuits**

**BUY RECORD BLANKS MARKED
KODISK**

"Snapshots of Your Voice"

a silvery disc made of a special metal on which you can record any sound clearly and distinctly on any phonograph, using the sound box and a KODISK needle as a recorder and reproducer.

The record blank KODISK is the greatest profit producing gem on the talking machine market—simple and attractive, an article which meets a long-felt want and which sells itself. The greatest merchants in the country are selling and featuring "KODISK" because they recognize its power to create new customers and profits. KODISK record blanks should be your feature number. TAKE ADVANTAGE of its quick selling qualities.

DON'T BE THE INNOCENT BYSTANDER. BUY discs marked "KODISK" AND BE PROTECTED AGAINST INFERIOR QUALITY AND UNLAWFUL MANUFACTURE.

We have a splendid proposition for progressive, well-equipped jobbers. Some choice territory still open. Write or wire TODAY for details.

METAL RECORDING DISC CO.

Manufacturers

**Fisk Building, Broadway and 57th St.
NEW YORK**

BRITISH KODISK, LTD.,

**4 ANSDALL STREET
Kensington, London, W. 8., England**

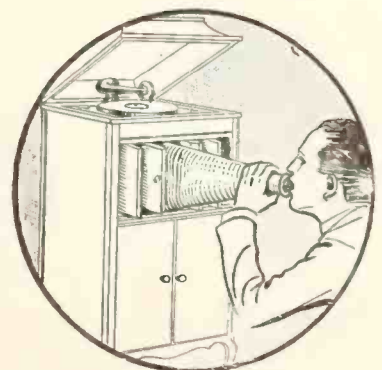

**Our A A A Quality
India Ruby Mica
DIAPHRAGMS**

Are, without doubt, the finest Diaphragms manufactured.

Samples and Prices on Request

WILLIAM BRAND & CO.
27 East 22nd Street New York City
Telephone, Ashland 7868

LOPEZ ORCHESTRA ACTIVE IN RADIO

Arrangements have been made whereby Vincent Lopez and his orchestra, exclusive Okeh artists and playing nightly at the Hotel Pennsylvania, New York, will broadcast a series of selections every Tuesday evening from the WJZ radio station at Newark, N. J. A program by Vincent Lopez and his orchestra was

DON'T BE AN UNDERTAKER

That's the position of a piano man when only selling pianos. He's like the undertaker who only gets his man once.



More Piano and Phonograph dealers have added Musical Merchandise Departments in 1922 than at any other time in the history of the Music Trade.

Every one of these dealers unanimously proclaims success with their adventure—no dull days—and the quick turnover of their new department more than pays all their overhead expenses.

A bigger year is ahead of you than can possibly be anticipated if you can supply your trade with the right kind of merchandise!

The policy of the house of Durro is: SUPPLYING DEPENDABLE NATIONALLY ADVERTISED MERCHANDISE OF QUALITY.

This is one reason that all merchants find it easy to sell such instruments as

**Durro Violins, Bows, Strings
S. S. Stewart Guitars, Banjos,
Ukuleles, Etc.
Duss Band Harmonicas
Lester and Monarch Accordions
Abbott Saxophones and Band
Instruments**

Dealers can assure their success for the next year in no better way than stocking this guaranteed merchandise.



BUEGELEISEN & JACOBSON
5-7-9 Union Square
NEW YORK

broadcasted from this station on Saturday, January 6, and on Friday, January 12, and the radio fans throughout the East were most enthusiastic regarding these concerts. This orchestra has won exceptional success during the past year and its Okeh records have met with a phenomenal sale in every section of the country. There is no doubt but that the radio concerts from the WJZ station will enhance the prestige and popularity of this orchestra among music lovers.

FRANK DORIAN JOINS STRAND JOBBER

Well-known Sales Executive Joins Staff of General Radio Corp. as Pittsburgh Manager—Ideally Qualified for This Post

PITTSBURGH, PA., January 6.—Frank Dorian, one of the best-known members of the talking machine trade, has been appointed manager of the Pittsburgh branch of the General Radio Corp., Strand and Okeh jobber. Mr. Dorian was for many years identified with the Columbia Graphophone Co., having occupied important executive posts in the different divisions of this company. He is an old friend of Geo. W. Lyle, president of the Manufacturers' Phonograph Co., making the Strand phonograph, and as this line of instruments is featured by the General Radio Corp. there is no question but that the dealers in this territory will receive maximum service in the development of Strand business. Mr. Dorian is also a former associate and friend of W. C. Fuhri, general sales manager of the General Phonograph Corp., manufacturer of Okeh records.

The executive offices of the General Radio Corp. are located in Philadelphia, Pa., and Walter L. Eckhardt, president of this company, who was formerly an executive of the Columbia Graphophone Co., is most enthusiastic regarding Mr. Dorian's association with the company's activities.

LOSES STOCK IN ASTORIA FIRE

Astoria Drug Co., Victor Dealer, Makes Quick Comeback After Disaster

ASTORIA, ORE., January 4.—The Astoria Drug Co., Victor dealer of this city, lost the entire stock at the company's main store in the big fire which struck the business section of Astoria recently. Two days after the fire Peter Paulson, proprietor of the company, and Mrs. C. Shaw, talking machine department manager, went to Portland and ordered a big shipment of goods for their little branch store, which was the only drug store in Astoria left standing for business: "A bigger and better city" is their motto and the loyalty of the citizens generally is marvelous and is bound to accomplish wonders.

R. L. WICKES ON EASTERN TRIP

Vice-president of Fletcher-Wickes Co., Finds Manufacturers Optimistic—Closes Several Important Deals—Plans Expansion

R. L. Wickes, vice-president and treasurer of the Fletcher-Wickes Co., Chicago, manufacturer of Fletcher tone arms, reproducers and attachments, was a recent visitor to New York. Mr. Wickes visited several of the talking machine factories in New York and vicinity and was pleased to learn that in practically every instance these manufacturers had closed a very satisfactory year.

Commenting upon general business conditions Mr. Wickes stated that his company had closed in the last half of 1922 sales totals far beyond expectations, making the year one of the most successful in the company's history. Mr. Wickes was particularly gratified at the fact that some of the best-known manufacturers in the industry had made arrangements for 1923 whereby Fletcher tone arms and reproducers would be used exclusively as standard equipment, and the Fletcher-Wickes program for 1923 includes expansion and better facilities.

MICA DIAPHRAGMS

Absolutely Guaranteed Perfect
We get the best India Mica directly.
We supply the largest Phonograph Manufacturers.

Ask for our quotations and samples before placing your order.

American Mica Works
47 West St. New York

H. B. BIBB ON CHAMBER COMMITTEE

District Sales Manager of Brunswick-Balke-Collender Co. a Member of Advisory Committee of Trade Service Bureau of Music Industries Chamber of Commerce

CHICAGO, ILL., January 8.—Harry B. Bibb, district sales manager of the Chicago branch of the Brunswick-Balke-Collender Co., has recently accepted membership on the advisory commit-



H. B. Bibb

tee to the Trade Service Bureau of the Music Industries Chamber of Commerce. His appointment is an important one, as the committee is charged with investigating and recommending to the board of directors those activities which should be undertaken by the Chamber along the lines of giving service to the various branches of the industry.

Mr. Bibb is well known by all members of the trade and the news of his appointment will be received with gladness by a host of friends and acquaintances.

WHY WORLD ADVERTISING PAYS

Brings an Order From Trinidad, B. W. I., to Manufacturer in Portland, Ore.

PORTLAND, ORE., January 4.—That it pays to advertise was fully demonstrated in a letter received by L. D. Heater, of 357 Ankeny street, Portland, Ore., from Trinidad, British West Indies, written by Alfredo L. Demorest, American vice-consul, who enclosed an international money order for 35 cents for one "Melo-Tone," which he stated he saw advertised in The Talking Machine World.

PUSHING RECORD DISPLAY FIXTURES

The exceptionally large record sales reported from all sections of the country have caused the Universal Fixture Corp., New York City, manufacturer of display fixtures, to centralize its selling campaign to the talking machine dealer to a large extent on the various record display fixtures in its catalog. This catalog now numbers forty separate numbers, five of which are made especially for record display, consisting of revolving racks, wall racks and counter easels.

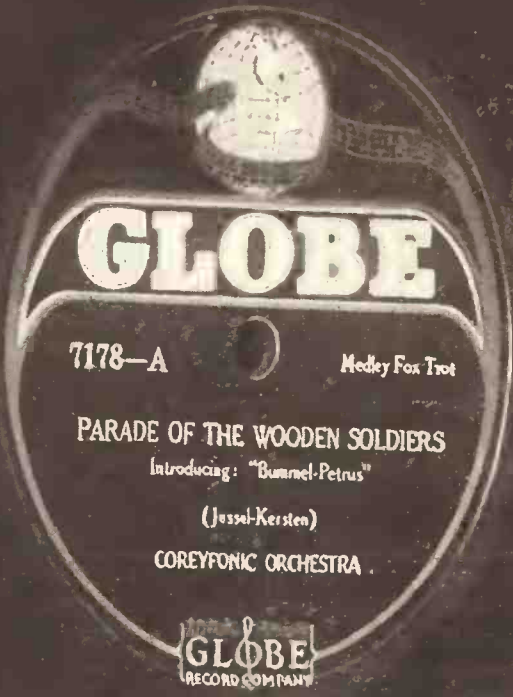

Fast selling means fast profits!

Globe record sales are growing beyond all expectations.

One demonstration—and Globe records are sold. The remarkably clear tone, the absence of noise, the wearing quality, the handsome appearance, are *the* selling factors which multiply sales and *profits!*

Globe records are *new-type*, improved records—different from all other records, better than all other records.

We will show you how our new, quick service plan and larger sales put profits into your record department far bigger than you have ever thought possible.

That is why dealers who have taken on Globe records *are* making money—because they *repeat*.

Globe Record Distributing Corporation
30 Church St., New York

Better than standard

Popular GLOBE Records

- 7191 Toot, Toot, Tootsie. Goo'bye—Fox-trot (D. Russo) California Ramblers
- Bees Knees—Fox-trot (T. Lewis-R. Lopez) California Ramblers
- 7188 Out of the Shadows—Waltz (W. Blaufuss) Symphonia Dance Orch.
- Red Moon—Waltz (H. de Martini) Symphonia Dance Orch.
- 7186 Homesick—Fox-trot (I. Berlin) Orpheum Melody Masters
- Down Old Virginia Way—Waltz (Oleman-Gillette) Symphonia Dance Orch.
- 7178 Parade of the Wooden Soldiers. Intro. "Bummel-Petrus". Coreyfonic Orch.
- Suez—Fox-trot (F. Grofe-P. De Rose) Coreyfonic Orch.
- 7174 Tomorrow (I'll Be In My Dixie Home Again)—Fox-trot. Golden Gate Orch.
- I'm Always Stuttering—Fox-trot (M. Pinkard) Golden Gate Orch.
- 7171 Lovely Lucerne—Waltz (F. Godin) Symphonia Dance Orch.
- Underneath the Mellow Moon—Waltz (W. W. Hall) Symphonia Dance Orch.

GLOBE Record Specials

- 7183 Paderewski's Minuet—Fox-trot...Coreyfonic Orch.
- Carolina in the Morning—Fox-trot (W. Donaldson) Coreyfonic Orch.
- 7185 Wicked Dirty Fires Blues—Fox-trot (L. Fowler) Original Memphis Five
- Stop Your Kiddin'—Fox-trot (F. Grofe-J. McHugh) Original Memphis Five
- 7182 Lovin' Sam the Sheik of Alabam'. Contralto Solo-Orch. Acc. Vaughn De Leath
- Where the Bamboo Babies Grow. Contralto Solo-Orch. Acc. Vaughn De Leath
- 7153 I Wish I Could Shim-mie Like My Sister Kate—Fox-trot. Original Memphis Five
- Pacific Coast Blues—Fox-trot (Hegamin-Hammed) Original Memphis Five
- 7187 Thru the Night—Waltz (T. K. Logan) Symphonia Dance Orch.
- Let Us Say Good-bye With a Waltz—Waltz (Squires) Symphonia Dance Orch.
- 7193 Piano Puzzle. (R. Reichenthal) Piano Solo—Ralph Reichenthal
- Breakin' the Piano. (Billy James) Piano Solo—Vee Lawnhurst

**RUSSIAN FOX TROT
BALLADE**



SONJA

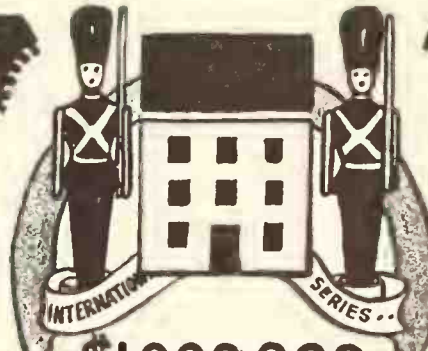

\$1,000,000.
MASTER FOX-TROT MELODY

**THE PARADE OF THE
WOODEN SOLDIERS**

**PARIS LONDON FOX TROT
SENSATION**



PELICAN

STOCK IN THE ABOVE-SHEET MUSIC RECORDS AND ROLLS, WRITE FOR SPECIAL OFFER AND COMPLETE CATALOG OF SHEET MUSIC
EDW. B. MARKS MUSIC CO. 223-25 W. 46TH ST. NEW YORK.

MUSIC AS A SOURCE OF MAN POWER

Fervor Excited by Tunes Heard Through the Medium of the Talking Machine Arouses New Life and Puts Fatigue to Rout

When the tired business man sequesters himself with the family talking machine, kicks off his slippers, turns on his daily dozen and proceeds to perform prodigies of more or less rhythmic contortions to a string of lively tunes, he is unconsciously demonstrating a fact of consciousness that is of deep interest to philosophers.

Bacon pronounced music "one of the subtlest pieces of nature," and the tired business man knows very well that the melodies that go with his calisthenics give him a power he would otherwise lack. He may not philosophize about it, as a writer in the Sun points out, but he feels it as a definite something, a fluid, as it were, coursing through his limbs, energizing them, making movement a pleasure and indefinitely postponing fatigue.

The same magical fluid shooting through the feet of the most delicate flapper—far too delicate, perchance, to wash the dishes—enables her to jazz madly until the cows come home, covering distances aggregating possibly from 50 to 100 miles a week.

Everybody knows what a difference a band makes to soldiers on the march and how the line is electrified when the "oom-pah" begins. And small-town folk must have observed that the most rickety of Odd Fellows or Mystic Shriners is capable of carrying the banner for miles and miles in the wake of the blaring town band.

And as for the highbrow music fans, the ones that haunt the symphony concerts and other classical music feasts, no tongue can tell what music means to them. But it is permissible for a comparative lowbrow to assume that whatever they get from it takes the form of an expansion of consciousness.

One of the most radical contentions of William James was that our normal waking consciousness is but one special type of consciousness, while "all about it, parted from it by the filmiest of screens, there lie potential forms of consciousness entirely different." And Professor James went on:

"We may go through life without suspecting their existence; but apply the requisite stimulus and at a touch they are there in all their completeness, definite types of mentality which probably somewhere have their field of application and adaptation. No account of the universe in its totality can be final which leaves these other forms of consciousness quite disregarded."

Music appears to open a door—or several

doors—into these generally hidden and unsuspected forms of consciousness. It seems fairly safe to surmise that Beethoven's Fifth Symphony throws one into a different state of consciousness from that excited by the "Broadway Blues."

While the tired business man is flapping his limbs and swinging his trunk to the tune of "Comin' Through the Rye" he may not receive much enlightenment as to the working of the cosmos, but Professor James says that serious music gives us "ontological messages"—that is messages of a divinity underlying the universe "which non-musical criticism is unable to contradict."

"There is a verge of the mind," he adds, "which these things haunt, and whispers therefrom mingle with the operations of our understanding, even as the waters of the infinite ocean send their waves to break among the pebbles that lie upon our shores."

Symphony concert fans ought to be able to grasp an Einstein universe which ever turns into itself like a snake swallowing its own tail. For there is much of the timelessness of eternity and the hereness of immortality appertaining to the fourth dimensional glimpses derived from highbrow music, with its "overcoming of all the usual barriers between the individual and the absolute."

MAX LANDAY HONORED BY BANK

Prominent Talking Machine Man Appointed Member of Harriman National Bank's Advisory Board—Possesses Wide Financial Knowledge—A Tribute to His Ability

Max Landay, head of Landay Bros., New York, and one of the best-known members of the talking machine industry, was honored this week by being appointed a member of the Advisory Board of the Harriman National Bank, New York. This banking institution is recognized as one of the strongest financial organizations in the country, and its advisory board includes some of the most prominent financiers and business men.

During his many years' association with the talking machine industry, Max Landay has specialized to a considerable extent on the financial end of the business. He has made a careful study of the dealers' financial problems, and has always been ready to give the trade the benefit of his knowledge and experience. His appointment as a member of the Harriman National Bank's advisory board is a distinct tribute to Mr. Landay's financial and executive acumen.

A patron who makes steady purchases is better than a new customer who makes one purchase and is not heard from again.

THE MAN WHO KNOWS IT ALL

J. H. Tregoe, Secretary-Treasurer, National Association of Credit Men, Descants on Pitfalls Awaiting the "Smart Aleck"

The man who knows it all is the man who is likely to make the biggest failure. When you find someone who does not need to be taught, whose knowledge comprehends all needful things, who can't see the value of mingling with others and exchanging ideas, you may at once conclude here is a man dangerous to go along with.

But when you run into the man whose attitude is that of a seeker of information bearing upon his work, who is conscious of the fact that even in his sphere of experience and observations others have some things he does not know and whose attitude is that of the explorer for new goals in his line of work, then one beholds the man who will take his graduate degree with high honors.

Have conceit about your superior knowledge and dry rot will set in. Healthy growth will come where there is eager spirit to secure the best equipment accompanied by a spirit of humility.

In this thought we have the reason why great prosperity destroys so many men. It makes men too sure of themselves. It gives them the feeling of individual sufficiency. They lose the point of view of interdependence among men. In such times men lose the sense of proper perspective.

We discover this in association work—men who were affiliated with trade organizations in times of prosperity, but were not so greatly impressed with the need of rubbing up against other men exchanging ideas and getting the best that is going on in their field. This egotism is expressed in "I know it all." And I say we must keep at our books, we must keep up our association with men so long as we are in active work and are carrying definite responsibilities. This is as direct a part of man's obligation to the enterprise which he is serving as is his obligation to devote himself to individual details of business. I earnestly crave big broadness of spirit among us credit men that will lead all of us, whether of larger or smaller responsibilities, to seek eternally ideas and standards that will help us do our part to keep business sound and ready at all times to meet the violent fluctuations that can scarcely be avoided so long as business conditions are subject to a great variety of world-wide influences.

The Lehman Piano Co., 1101 Olive street, St. Louis, has added to its sales staff Mrs. B. F. Uppinghouse, whose sole duty is outside solicitation of record business.

FREE VOICE RECORDING PHONOGRAPH RECORDS

How to Make Your Own Records

Place this marvelous disc (same size as illustration) in your phonograph, put on a loud needle, start phonograph as you would with any ordinary record, then **SING OR TALK INTO THE SOUND BOX.** When you have finished, simply play the record over again and you will **HEAR YOUR OWN VOICE.** Use the same disc

FREE! for just a few days only

How to Get One

Simply get one friend to sign the coupon below and mail to the Premium Department of the Herald and Examiner, Room 207 Hearst Building, 326 W. Madison St., Chicago

HERALD EXAMINER RECORD

Contract for Delivery of Paper

To be signed by the advertiser and returned to the Premium Department of the Herald and Examiner, Room 207 Hearst Building, 326 W. Madison St., Chicago

For the advertiser to sign and return to the Premium Department of the Herald and Examiner, Room 207 Hearst Building, 326 W. Madison St., Chicago

NAME _____

ADDRESS _____

CITY _____ STATE _____

DATE _____

Marvel Voice REPRODUCING RECORD

When a great newspaper uses 'Marvel Voice' to get business it must be a sensation!

CHICAGO HERALD EXAMINER

*A full page in this Sunday Edition costs

\$2,240.00

On January 7th this full-page advertisement appeared in the Chicago Herald Examiner, offering one Marvel Voice record free with each three months' subscription to the paper.

In New York City during Christmastime the stores cleaned up on the record that enables you to "hear yourself as others hear you."

The Marvel Voice reproducing record is, at this moment, as great a sensation in New York City as it is in Chicago, where a great newspaper capitalizes its tremendous profit-bringing possibilities.

From 50-year-old fathers to 10-year-old sons, they flock in to your store for Marvel Voice Records, and take them home for a little self-made opera. They send their voice by mail. They make a record of the baby's voice for remembrance's sake. Everybody's doing it—and you cash in big on its popularity.

*** Don't delay**—exclusive representatives have already been appointed in some territories; there are many choice territories still open. For further details and samples—**write today.**

MARVEL RECORD COMPANY

37 East 20th Street

New York City

GLOBE RECORDS MAKING PROGRESS

M. E. Schechter Announces Appointment of Three Wholesale Representatives—Important Territories in Capable, Practical Hands

M. E. Schechter, president of the Globe Distributing Corp., New York, manufacturer of Globe records, announced this week the appointment of Geo. E. Seiffert, 929 Broadway, New York, as exclusive wholesale representative for the company in this territory. Mr. Seiffert, who is one of the most popular members in the wholesale trade in the East, will represent Globe records in Greater New York and in New York State, east of the Hudson and as far north as Albany.

Lionel M. Cole, who has been identified with the talking machine industry for many years and who numbers among his personal friends dealers throughout New York State, has been appointed wholesale representative for Globe records, with headquarters in Buffalo. Mr. Cole will work in a territory where he is thoroughly familiar and he brings to the Globe organization an invaluable experience.

D. W. Prater, who has been associated with Southern musical activities for many years, has been appointed Globe wholesale representative for the States of Alabama, Mississippi and Tennessee, west of Chattanooga. Mr. Prater, who will make his headquarters in Millport, Ala., is keenly enthusiastic regarding the sales possibilities for Globe records in the South.

NIXON MUSIC CO. CHARTERED

WHITEFISH, MONT., January 7.—The Nixon Music Co., of this city, has been granted a charter of incorporation under the laws of this State, with a capital stock of \$20,000, to conduct a general music merchandising business. Cecil C. Nixon is president and A. N. Steele is secretary and treasurer. The first store of the company will be established in this city, which will also be the headquarters, and elaborate plans are being made for the opening of a chain of stores in other important cities throughout the State.

HEMPEL DELIGHTS IN CONCERT

Miss Frieda Hempel, Edison artist and famous soprano, gave her second New York recital of the season at Carnegie Hall on the evening of January 9 when she delighted a great audience with a group of Seventeenth Century songs of Switzerland which she discovered during her vacation days at Sils Maria last Summer. She also sang in her inimitable style four immortal German songs and a group of famous Irish songs, which, it goes without saying, were charming. She closed her concert with Strauss' waltz song, "Voce di Primavera." Previous to her tour of the Southwest, where Miss Hempel is scheduled to give twenty-five Jenny Lind

DIRECT FACTORY PRICE—JUST MENTION THE QUANTITY

| | | | |
|---|--|--|--|
| <p>MOTORS CASTINGS REPRODUCERS</p> | <p>Grey Iron and Brass for</p> | <p>TURNTABLES MOTOR FRAMES TONE ARMS HORNS and THROATS</p> | <p>Stylus Bars Screw Machine Parts Talking Machine Hardware</p> |
|---|--|--|--|

Direct Quantity Importations On { **JEWEL and STEEL (Bulk or Packed)**
PHONOGRAPH NEEDLES
GENUINE RUBY BENGAL MICA

D. R. DOCTOROW

Vanderbilt Ave. Bldg.
51 East 42nd Street, New York
Tel. Vanderbilt 5462
Murray Hill 800

concerts, she is to appear as soloist with the New York Symphony Orchestra in Washington on January 15 and in Baltimore on January 17 under the baton of Arthur Coates.

RCA PRODUCTS EXHIBITED AT SHOW

Radiola Four and Radiola Grand Attract Wide Attention at New York Show—RCA Displays Visited by Thousands—Many Sales to Radio Fans Made at Booths

The Radio Corp. of America, manufacturer of RCA radio products, maintained at the recent radio show in New York one of the most attractive exhibits that has ever been presented at the Grand Central Palace. The company occupied two very large exhibition spaces, and among the instruments shown were the new Radiola four and Radiola grand, both of which attracted considerable attention. There were also on display Radiolas five and six, and it is interesting to note that a large number of sales were made at the booths to interested radio fans.

Various charts, diagrams, etc., regarding radio transmitting were carefully studied by the throngs who visited the show and among the literature distributed at the RCA booths was a world time chart giving the time of day in practically every large city in the world. George F. Clark, who is in charge of all of the Radio Corp. of America's show exhibits, prepared all of the details incidental to the New York show, and was ably assisted by H. C. Gawler of the sales department, together with several other members of the executive office staff in New York.

C. W. FLOOD'S NEW SALES POST

PHILADELPHIA, PA., January 5.—C. W. Flood, well known in the local trade, has joined the staff of the General Radio Corp., of this city, Strand and Okeh jobber, and will co-operate with the dealers in this territory along practical lines. Mr. Flood is a keen admirer of the Strand phonograph and was identified with several of the previous activities of Geo. W. Lyle, president of the Manufacturers' Phonograph Co., New York, which makes the Strand phonograph.

CLOSES PROSPEROUS YEAR

Outing T. M. Co. Making Plans for Expansion During 1923—New Finishes Will Be Ready Soon—A. J. Coté Optimistic

Mr. Kisco, N. Y., January 5.—The Outing Talking Machine Co., Inc., of this city, manufacturer of the Outing portable machine, has closed a very prosperous year, and A. J. Coté, president of the company, states that the month of December was the biggest in the entire year. Several of the company's jobbers have already placed their orders for January shipments and practically every Outing jobber started the new year with no stock on hand.

In a chat with The World regarding general conditions Mr. Coté stated: "We are firmly convinced that the Outing is not a seasonable machine, but one which can be merchandised profitably the year round, and with this idea in mind we will announce very shortly new finishes that will match almost any type of furniture. We have also perfected our method of packing, thereby assuring delivery of the machines in the same condition as when they leave the factory. During the year we expect to co-operate with our jobbers and dealers to the fullest extent in the way of show window displays, descriptive circulars, etc.

"We are convinced that 1923 will be a banner year for the portable machine, especially the instrument of the better type. The reception accorded the Outing the past year has been most gratifying and we deeply appreciate the co-operation received from every factor of the trade."

PLANS EXTENSIVE SALES DRIVE

The Kirkman Engineering Corp., New York City, has planned an intensive selling campaign on its products for the talking machine trade—the K-E automatic stop and the K-E and Simplex record cleaners. The policy adopted during the latter part of 1922 of imprinting the dealer's card on these metal cleaners has proved very attractive to the trade and has made these cleaners an advertising as well as a resale proposition for the talking machine retailer. With the added impetus gained through this drive the sales volume should be the best ever.

My won-der-ful one, When - ev - er I'm dream-ing, Love's love-light a-gleam-ing, I see.—

Wonderful One

Music by **PAUL WHITEMAN** and **Ferdie Grofé**

Lyrics by **Dorothy Terriss**
author of "Three O'clock in the Morning"

You can HEAR IT and BUY IT-HERE!

BIG WALTZ HIT

"You can't go wrong With any FEIST song"



THE ORSENIKO PERIOD PHONOGRAPH



BUCKINGHAM

Grace in its proportions; exquisite hand carvings, which further accentuates its beautiful lines, and decorations by artists who are masters of the art, have made for this cabinet a place in many homes of refinement.

Dealers who are desirous of enhancing the value of their exhibit are adding all or a part of our line to their display.

THE ORSENIKO COMPANY, Inc.

*Showroom: 112 West 42nd Street
New York City, N. Y.*

*Factory: Skillman Ave. and Rawson St.
Long Island City, N. Y.*



PORTLAND, ORE.

*Business Satisfactory—Leading Dealers Optimistic and Energetic
—Banquet of Bush & Lane Staff—News and Changes of Interest*

PORTLAND, ORE., January 6.—Growth of water commerce, increase of manufacturing and, particularly, efforts to solve the farmers' problems are all indicative of better times in 1923, Portland business leaders believe.

Investments are on the increase, especially in manufacturing fields, they point out, and settlement of many commercial claims has provided a better foundation for enterprise, all of which will be reflected in all lines of business.

Never before has the lumber industry prospered as it is prospering now. Considerable new small manufacturing is starting in Portland and several local industrial projects of size will begin during the present year and the city's population is steadily increasing.

That December music business for 1922 far exceeded that done in 1921 is the consensus of opinion of all the music dealers.

Elmer Hunt, wholesale manager of Sherman, Clay & Co., gives out a splendid report for December to the effect that the entire Oregon territory shows a big increase over last year with prospects for 1923 most bright.

The Heyne Music Store, of Lebanon, Ore., L. E. Heyne, proprietor, has succeeded the Sears-Kerr Drug Co., of that city, as Victor dealer.

Batchelor & Rohrbough, furniture dealers of Albany, Ore., have put in the Victor line, which they will carry exclusively. Mrs. Olga Moreland, formerly of the Huntly-Draper Drug Co., of Oregon City, and well known to the music trade, has been placed in charge of the new department.

The talking machine department of the Reed-French Piano Co., Allen E. McLean, department manager, reports an increase in December of about 25 per cent over last year and says: "Our wonderful business in Edison and Victor machines was only limited by the jobber not supplying the necessary instruments. The people of Portland bought freely of good merchandise and cash receipts were unusually heavy."

Frank B. McCord, well known in the trade, has been appointed sales manager of the Reed-

French Piano Co., taking up his duties the first of last month.

William Hodecker, manager of the talking machine department of Meier & Frank Co., reports December as the biggest month in the history of the store with business far exceeding anything ever done before. Five extra girls were added to the sales department to help out during the holiday trade and all were kept "on the jump" supplying the big demand for the Victrola, Edison, Columbia and Vocalion machines and the Victor, Columbia and Edison records.

L. D. Heater, of 357 Ankeny street, distributor of the Strand console phonograph, Thomas Portophone and phonograph accessories, reports good December business with a tremendous increase over last year. Mr. Heater says: "The Strand machine is receiving an unusually warm reception in my territory and much more business would have been done with this line if a delayed shipment had only reached me in time for the Christmas trade."

Arthur W. Stein, manager of the Victrola department of Sherman, Clay & Co., reports a most satisfactory holiday business and says: "We are just beginning to get our breath again, and I am happy to say that there were no casualties among our force in spite of the break-neck speed of the last several days." From all appearances the good work is still going on, for while there The World correspondent saw Nellie Mugler surrounded on all sides by Red Seal records, and when asked by the "inquisitive one" what she was going to do with them all—where they were going—how much the cost, etc., etc., she calmly remarked: "Oh, I just sold these to a customer of mine from Grants Pass." The sale amounted to \$81.75, and the report is that over half of them were sold on the confidence the customer had in Miss Mugler's choice.

The annual banquet of the Seattle Bush & Lane Piano Co., which was held at the Hotel Washington annex New Year's Day, was attended by J. C. Gallagher, manager; George Darrell, sales manager; J. P. Darnell, assistant manager; F. S. Stroud, bookkeeper; J. L. O'Gara, credit manager, all of the Portland Bush & Lane store. On their return they reported a most enjoyable time.

Invitations for the banquet of the Portland branch of the Bush & Lane store are out and some of the department heads of Seattle are expected to attend along with C. T. Corbin, general manager.

The E. B. Hyatt Talking Machine Co., Oregon's largest exclusive phonograph dealer, specializing in the Victrola, Edison, Brunswick and Columbia machines, along with the Victor, Brunswick, Columbia and Edison records, says: "December was great and our holiday trade immense, with the sale of the Edison baby console and the Brunswick York far exceeding our most sanguine expectations." Mr. Hyatt is another dealer to back up the console machine as the one to be reckoned with and reports 70 per cent of his machine sales for December to be of the console type.

The Seiberling & Lucas Music Co. opened for business in its new location at 151 Fourth street on January 2, but Mr. Lucas says: "We are doing business under difficulties, for things are far from being adjusted and the formal opening of our new store will not be held officially for two or three weeks, when everything will be shipshape."

The phonograph department of Lipman, Wolfe & Co., which for the past several years has been owned and operated by Roy Feldenheimer, has been sold to the Portland Piano Co., which already operates the piano depart-

ment in the Lipman, Wolfe store. O. J. Mishand has been placed in charge of the department, which carries a complete line of Sonora, Brunswick and Steger phonographs, as well as the Brunswick records.

The McDougall-Conn Music Co. on Tenth street successfully closed out its complete line of Columbia Grafonolas and records, preparatory to moving to a downtown location where it will only have room to specialize in musical merchandise and sheet music. W. A. McDougall reports that the move will not be made before April 1.

I. D. Flemming, former phonograph salesman of the Bush & Lane Piano Co. and of the Remick Song Shop, has been added to the phonograph department of the Meier & Frank Co. to take the place of A. C. Sherbert, who resigned in order to devote all of his time to the management of his recent phonograph accessory invention—the "Melo-Tone."

C. L. Neilson, manager of the Brunswick and Victrola department of the Wiley B. Allen Co., reports excellent holiday business, as does also Erma Erwart, of the record department.

Harry L. Nolder, general manager of the Coast division of the Starr Piano Co., was a recent Portland visitor and spent several weeks with Charles Soulé, district manager, looking over the Oregon territory. Mr. Soulé reports excellent business with the Starr phonograph and Gennett record and says his only trouble is to get the goods and that the factory can't make the phonographs fast enough to supply the demand. The Gennett records come through in good style, according to Mr. Soulé.

CHICAGO DEALER FEATURES SONORA

The Dimel Music Shop, of Chicago, has the distinction of being the oldest music store in that city outside the "Loop." The picture shown herewith is the interior of the new store re-



Warerooms of the Dimel Music Shop recently opened by the company on West North avenue. Sonoras are featured to excellent advantage in the Dimel warerooms and during the holiday season the sales were limited only by the available merchandise.

BIG YEAR FOR COLUMBIA MANTEL CO.

C. H. Gudogast, secretary of the Columbia Mantel Co., Brooklyn, N. Y., manufacturer of cabinets for the talking machine trade, reports that 1922 was a big year. During that period the company also entered the radio field, making cabinets for a number of the large manufacturers of radio sets. He reports that there is a particularly strong demand for console cabinets and in response to this demand the company has prepared a number of attractive console types. Mr. Gudogast and the other officials of the company are looking forward to a big business during the year which has just opened.

REPORTS INCREASING SALES

MURPHYSBORO, ILL., January 2.—President T. Martin Morgan, of the Morgan Music Co., reports an unusually heavy demand for used phonographs of all makes. The company of which he is the head has rented the room formerly occupied by Carp & Co.

Model 75, Sample \$27.50 Queen of Phonographs

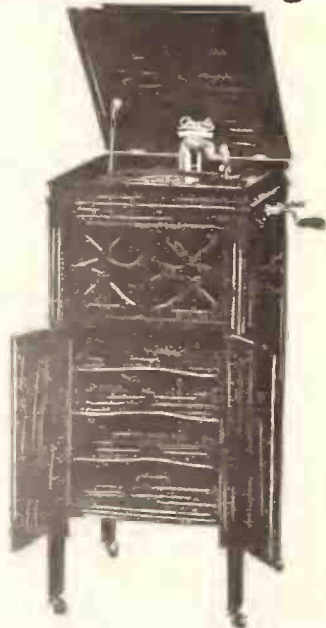

Mahogany, 41 x 17 x 19, double spring motor, Universal Tone Arm.

Send for Sample To-day

TERMS—Cash with order or a small deposit and balance C.O.D.

Phonographs and Accessories, Repair Parts for All Makes.

Puritone and Truetone needles at 25¢ per M in lots of 10 M and up.

ASK FOR CATALOGS and Price Lists of our No. 35 and 50 Machines. It will pay you.

FULTON TALKING MACHINE CO.

253-255 Third Ave., New York City
Between 20th and 21st Streets

Widdicomb
 PHONOGRAPH
The Aristocrat of Phonographs

Do you get the best class of trade?

Do discriminating phonograph buyers award you their esteem and patronage?

PEOPLE of taste and refinement admit unhesitatingly the two-fold appeal of the Widdicomb—its unusual tonal beauty and faithfulness of reproduction, and its exquisite cabinet work in popular period styles.

Merchants handling the Widdicomb find that they are building a steadily increasing patronage and prestige among the most discriminating buyers. Are you getting *your* share of this class of trade?

Investigate the Widdicomb franchise, learn how you, too, can command the business and the esteem which accrues to the Widdicomb dealer. Write today for complete catalog and full particulars.

THE WIDDICOMB FURNITURE COMPANY

Grand Rapids, Michigan

Fine Furniture Designers Since 1865

NEW YORK: 105 W. 40th Street

CHICAGO: 327 S. La Salle Street

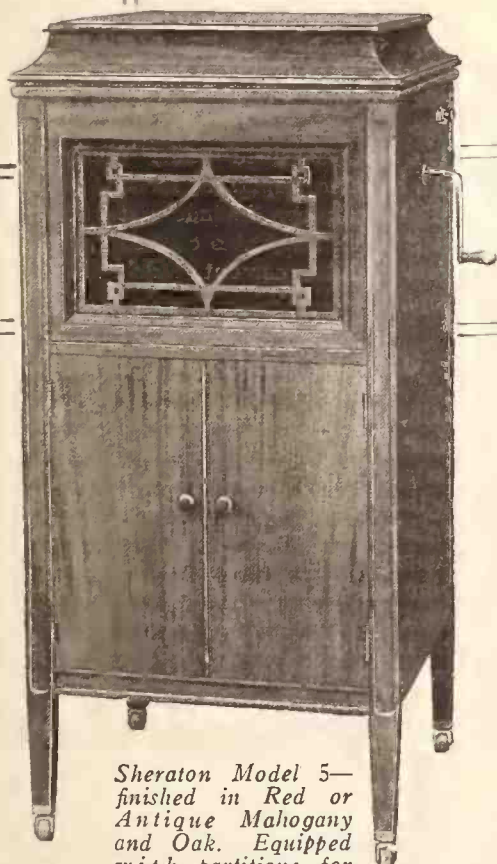

Sheraton Model 5—finished in Red or Antique Mahogany and Oak. Equipped with partitions for records, automatic stop and patented tone control.



Chippendale Model 4—finished in Red or Antique Mahogany and Walnut. Equipped with albums for records, automatic stop and patented tone control.

Widdicomb Phonographs in Period Styles are faithful interpretations of the best designs of the old masters of the art of wood-fashioning. They are the handicraft of an organization which for three generations has enjoyed a reputation for leadership as designers of fine furniture. Widdicomb Phonographs play all records. New prices on the various models range from \$90 to \$260.

STRIKING NEW EDISON POSTERS

Edison Record Releases to Be Announced by Dealers Through Artistic Window Posters

The new posters, by which Edison record releases will henceforth be announced, made their debut this month. The headpiece for the releases is a striking red, black and white poster, about two feet wide. On either side is a reproduction of an Edison record and in the center the title which reads "Edison Recent Record Releases." This headpiece is designed to be mounted by the retail dealer on a bulletin board in his window, at various places in his store and in each demonstration booth. Under it are to be placed the posters announcing specific releases.

The posters announcing standard, classical and ballad numbers are printed in black and white and contain the name of the selection, the artist making the record and the origin of the selection. In the center is a reproduction of the Edison record label. The posters announcing the popular numbers are of the same width, but are deeper and are printed in striking color effects and in each case are designated as "Flashes From Broadway."

This new Edison plan of releasing records was announced in *The World* last month and became nationally effective the latter part of January. It is a plan whereby no regular monthly supplements are issued, but a representative number of popular, standard and classical selections are released each month and individually announced. It is a plan which contemplates keeping up a continuous, newsy interest in new Edison records and a permanent agency for bringing people into the stores of Edison dealers at regular and frequent intervals.

E. C. BOYKEN WITH C. B. HAYNES

E. C. Boyken, for many years a member of the Edison phonograph industry and representative of the factory and later of the Phonograph Co. of Manhattan, has joined C. B. Haynes, Edison jobber, located at Richmond, Va. Mr. Boyken took up his new work as sales manager of this important jobbing concern about the middle of January.

F. C. Beatty, assistant to the vice-president of Thomas A. Edison, Inc., spent a fortnight over the holiday period with his family in Dallas, Tex.

NEW UNICO CHICAGO MANAGER

George A. Lyons Promoted to Western Sales Manager, With Headquarters at Chicago

CHICAGO, ILL., January 10.—George A. Lyons, formerly assistant sales manager of the Unit Construction Co., of Philadelphia, Pa., manufacturer of Unico equipment for talking machine warerooms, has been promoted to the position of Western sales manager and will direct the mid-Western sales activities of this company from its Chicago office. W. D. Montgomery, for the past year in charge of the Chicago office, has resigned that position. The territory to be operated from the Chicago office will number fourteen States, including from Ohio to Kansas and Tennessee to North Dakota. Mr. Lyons will have as his assistants H. C. Baish and W. K. Badger, both of whom have exceptional sales records with the company. B. S. Mahoney will remain in charge of Chicago office details.

It was stated by an official of the company that the enlarged organization operating from the Unico Chicago headquarters is indicative of the company's increased activities in the Western territories and in keeping with its policy of giving the local trade service of the highest efficiency.

EXTENSIVE COLUMBIA CAMPAIGN

Gigantic Newspaper Campaign Prepared by Columbia Co. Covers Every Section of the Country

The Columbia advertising program for 1923 includes one of the most intensive and important newspaper campaigns that has ever been prepared in the talking machine field. Over 700 papers are represented on the Columbia 1923 list, covering practically the entire country, and including almost every city of appreciable size.

In outlining this campaign the United States was divided into two sections and on this basis the newspapers in the smaller towns will feature the monthly Columbia record releases once a month. In the second group, comprising newspapers in the larger cities, full-sized advertising will appear the 10th and 20th of the month, announcing new Columbia records, and three-inch copy will be used in some one paper every day, thereby giving Columbia products representation every day of the week. Columbia dealers have been advised of this campaign and are planning to co-operate with the company in every possible way.

DIFFICULT SUBJECT WELL HANDLED

Columbia Dealer Features "Three o'Clock in the Morning"—Display Produces Results

SALT LAKE CITY, UTAH, January 8.—The Glen Bros.-Roberts Piano Co., of this city, progressive Columbia dealer, recently used a very attractive window display featuring the Feist hit, "Three o'Clock in the Morning." Using a reproduction of a large mahogany clock and

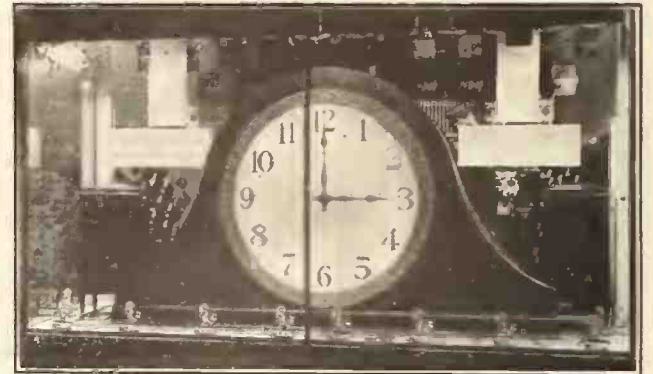

Attractive Window Display

flanking it on both sides with Columbia Grafonolas, with Columbia records of "Three o'Clock in the Morning" as a background, this difficult subject was reproduced originally and effectively. The window display attracted a large crowd, and according to the sales reports the display stimulated the sale of the record materially.

NEW EDISON CATALOGS MAKE DEBUT

Comprehensive Catalog for Dealer Distribution and for Reference—Another for the Special Use of the Purchasing Public

During January the new Edison 1923 record catalogs made their debut. One catalog entitled "The Edison Annual Record Catalog for Dealers' Use" is a very comprehensive volume of over five hundred pages in which all records are listed and classified under every possible heading. It is the belief of the Edison Co. that this complete information is only needed for the use of Edison dealers and their sales staff, and this volume is therefore especially prepared for their use and is equipped with a chain whereby the dealer may install it in a booth or on a counter for the reference use of the public.

In addition to the dealer catalog a very handsome 1923 record catalog has been prepared for the use of the purchasing public. This includes a complete listing of all the Edison records, but is made up in the briefest and clearest style possible. It is handsomely bound in red linen and the title is stamped in gold. Selections are classified under fourteen headings, such as dance, operatic, foreign, piano, etc.

Both catalogs include over three thousand selections. They also contain full-page illustrations of all the current models of Edison phonographs.

GEO. W. LYLE ON WESTERN TRIP

Geo. W. Lyle, president of the Manufacturers' Phonograph Co., left New York on Saturday for a Western trip, which will include a visit to the headquarters of the Consolidated Talking Machine Co., Chicago, Strand jobber. This company is now opening a handsome Strand saloon on the second floor of its building at 227 West Washington street, and Mr. Lyle accepted an invitation to be present at the formal opening.

LINKED UP WITH THRIFT WEEK

The advertisements prepared by Thomas A. Edison, Inc., for the use of Edison phonograph dealers during the month of January, were made to link up in an effective manner with the National Thrift Week that has become a regular annual feature of January.

Watch the Man With the Advertising Idea

—he may be the coming brains of your business

Look over the young executives who direct the retail and the manufacturing business of New York.

A surprisingly large percentage of them have reached their goals by advocating advertising, by directing the advertising and by making the advertising work.

If yours is a business which doesn't advertise, don't close your ears to the story of your young men. Help them to think it out—listen to their plans and their hopes. Add the counsel of years of experience to the minds of the men who are planning the future of your business.

Did you ever expect that iron could be advertised profitably? Few advertising men did. Did you ever expect to eat trade-marked grapefruit? It is an accomplished fact at thousands of breakfasts this morning. Did you ever think the dairymen could profitably use the forces of publicity, or that a barbershop could grow to twenty-five, largely by the power of the written word and an ideal of service?

The coming executives realize that a business exists, in the last analysis, in the minds of its customers, rather than in four walls and a roof, and perhaps that is why they are the coming executives.

[Published by The Talking Machine World in co-operation with The American Association of Advertising Agencies]

REPAIRS

TALKING MACHINE TROUBLES AND HOW TO REMEDY THEM

Conducted by Andrew H. Dodin

The Question of Horns

"Stapleton, N. Y., January 2, 1923.

"The Talking Machine World, New York.

"Gentlemen:—Some years ago I purchased from a local store a talking machine having an all-wood horn chamber. This machine played very well for some time, when, through an accident, the sound box was broken off at the point of connection with the tone arm. Through a local dealer I purchased a complete tone arm and sound box, which I heard tested on a machine in his store, and placed same on my machine. I was surprised at the lack of tone in my machine in comparison with the one I heard at the dealer's and I made a call on the dealer and examined his machine in detail. The only apparent difference that I could see was in the material of the horn, which in the dealer's machine was made partly of tin, and also that there was no tone controller in the horn.

"Could you inform me what I can do to change over my machine in such a way as to obtain a better reproduction? Would you suggest making a new horn entirely? Inasmuch as the tone arm and sound box reproduces good on the one machine there surely must be some way in which my machine could be made to equal it.

"H. E. Williams."

Answer:—Without doubt the trouble in your machine lies in the horn. There is no doubt that a tin horn, or three-quarter tin horn, will give you more volume of tone than an all-wood horn, but probably not the same quality of tone. There is also a possibility that at the point of connection with the horn of the tone controller there is more or less of an open space which will permit tone to escape. A tone controller to be effective and still not interfere with the original value of the horn must be fitted with accuracy and care taken that there is no open space left, and also that the slide is not left loose so that it will vibrate. A good plan is to cover the slide with a piece of felt.

Repairing a Balky Motor

"Spring Lake Beach, N. J.,
December 30, 1922.

"Andrew H. Dodin,

"The Talking Machine World,

"373 Fourth avenue, New York.

"Sir:—I would greatly appreciate it if you would advise me of the probable causes of a motor playing out of tune. I have one (Emerson) that I cannot seem to remedy. Lubrication, end play and sliding sleeve seem all O. K. (I refer to the governor). Also the same governor when placed in another Emerson plays all right. Do not think it worth while to send to you.

"W. E. PaDelford."

Answer:—According to your letter you have taken care of the graphite, end play in the governor and sliding sleeve, so that it would not be necessary to make any further adjustments to that part of the motor. Undoubtedly your trouble is caused by a faulty fibre gear on the turntable spindle. Unless these fibre gears are cut absolutely true they will very seldom mesh accurately with the spiral cut on the governor spindle.

The chief causes of the motor playing out of tune are the following: Springs not graphited properly; governor not having end play; governor sleeve binding on the governor spindle; governor balls of uneven weight; turntable spindle fibre gear teeth being out of true or having some of the teeth damaged by being nicked; spring cage shaft too tight in its bearings; intermediate gears binding in their bearings, or the turntable rubbing against the brake or some part of the automatic stop.

If you look to all of these causes and have same in proper adjustment there is no reason why the motor should not run in proper tune or pitch and prove satisfactory.

W. C. GRIFFITH VISITS NEW YORK

Sales Manager of Chicago T. M. Co. Calls at New York T. M. Co.'s Headquarters—Local Dealers Receive Gold Pencil as Christmas Token—I. Son Cohen a Visitor

W. C. Griffith, sales manager of the Chicago Talking Machine Co., Victor wholesaler, was a visitor this week to the offices of the New York Talking Machine Co., spending a few days in New York, after visiting the Victor factories at Camden. Mr. Griffith spoke enthusiastically of business conditions in Chicago, stating that in every section of this territory Victor dealers had closed a splendid holiday business.

I. Son Cohen, head of Cohen & Hughes, Baltimore, Md., Victor wholesalers, accompanied by several of his department heads, visited the New York Talking Machine Co. headquarters a few days ago. Mr. Cohen carefully inspected the modern and up-to-date equipment used in this jobber's establishment and was greatly impressed with the attractive appearance of the floor.

The New York Talking Machine Co. forwarded to its dealers at Christmastime a handsome Eversharp gold pencil, accompanied by the wish that these pencils would be used continuously during 1923 to enter up a record-breaking business.

EDISON DISC JOBBERS TO MEET

National Edison Disc Jobbers' Association Makes Elaborate Plans for Convention to be Held in New York City in February

On February 12, 13 and 14 a meeting of the National Edison Disc Jobbers' Association will be held in New York City at the Hotel Waldorf. A 100 per cent attendance is anticipated and plans for a constructive program are now in process of making. The plans will include a number of conferences with the officials of Thomas A. Edison, Inc. A feature of the 1923 convention will be the celebration of the seventy-sixth anniversary of Thomas A. Edison, which occurs on Sunday, February 11. Already buttons have been sent out to every member affiliated with the Edison industry, including the phonograph, electrical and Ediphone divisions. These buttons feature the numerals "76" and the name "Edison," and the celebration of this important birthday is certain to prove an event of national significance.

PROVING HIGHLY POPULAR

The handsome bronze metal banks, which are miniature replicas of the Edison console models, and which Edison dealers are offering to prospective purchasers of Edison phonographs or Edison records, are proving highly popular. The distribution of these banks is already assuming very large proportions and it is obvious that the public are quick to appreciate this handy means of enabling them to save to buy records or pay instalments on phonographs.

PLANS NEW EDISON STRUCTURE

Texas-Oklahoma Phonograph Co., Edison Jobber, Headed by A. H. Curry, to Construct Well-equipped Building in Dallas, Tex.

DALLAS, TEX., January 8.—The Edison jobbing concern headed by A. H. Curry, who is also vice-president of Thomas A. Edison, Inc., and manager of the phonograph division, is inaugurating an ambitious program for 1923, and in view of Mr. Curry's dual connection one which ought to stand as a very impressive inspiration to other Edison jobbers and Edison retailers throughout the country.

The Texas-Oklahoma Phonograph Co., wholesale distributor of the Edison phonograph, will start construction soon on a three-story and basement office and warehouse building on lower McKinney avenue near Lamar street in the Katy industrial district, Oscar G. Feltner, secretary-treasurer of the company, announced recently. The building will be erected at a cost of approximately \$50,000.

"Increasing business in the Southwest territory and revived prosperity have combined to force the company to seek larger and permanent quarters here," Mr. Feltner said. "It is hoped at this time to get into the new building by March 1, 1923."

A. H. Curry is president of the concern, which has headquarters in Dallas, while A. C. Dennis is manager of the Dallas branch of the company. The Texas-Oklahoma Phonograph Co. has been located in Dallas since 1915, having moved to this city from Fort Worth. It was incorporated in 1914.

Shipping offices as well as storage space will be included in the new structure, Mr. Feltner declared, adding that space will be reserved on the McKinney avenue side for offices. The property has recently been acquired by the company for the structure.

Trackage facilities will be furnished the new building by the Katy railroad.

LEAVES ON PACIFIC COAST TRIP

A. R. Karch, general field representative of the phonograph division of Thomas A. Edison, Inc., recently left for the Pacific Coast, where he will make a complete survey of the Western territory. On the return trip he will stop at Helena and Ogden and this will finish the complete national survey he has made of each territory served by the jobbers of Thomas A. Edison, Inc.

JOHN F. DITZELL RESIGNS

ST. LOUIS, Mo., January 8.—John F. Ditzell, who has been manager of the music salon at the Famous & Barr Co. since February, 1917, has announced his resignation to take effect on February 1. He will reveal his future plans at an early date.

FIRE DAMAGES EMERSON SHOP

MANCHESTER, N. H., January 8.—The Emerson Phonograph Shop, East Broadway, this city, suffered damage estimated at \$3,000 in a fire last week. A number of phonographs and pianos were destroyed before the flames were brought under control.

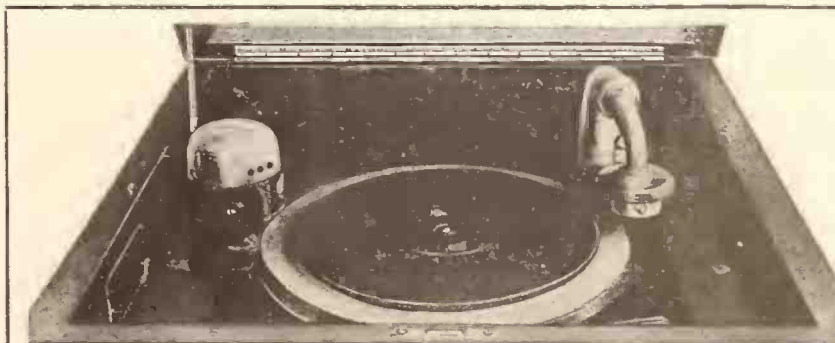

THE SHELTON Electric Motor

The "Simplicity" electrifies Victor, Edison and Columbia phonographs by simply taking off winding handle and placing motor against turntable. Automatic switch in motor operated when the turntable is started or stopped. Operating on AC or DC current of 110 volts. Specify type of current when ordering.

SHELTON ELECTRIC CO., 16 East 42nd Street, New York

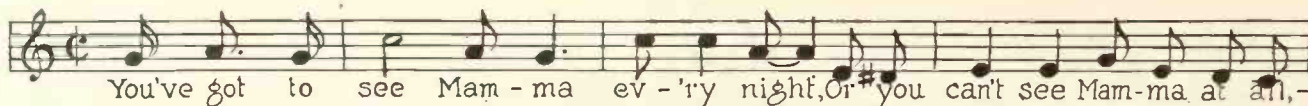

You've Got To See Mamma Ev'ry Night

(or you can't see Mamma at all)
A lonesome, lovesick "Come to Mamma" Blues,

You can HEAR IT and BUY IT HERE

| | | | | |
|------|----|----|----|----|
| Sun. | X | X | X | X |
| Mon. | X | X | X | X |
| Tue. | X | X | X | 12 |
| Wed. | 13 | 14 | 15 | 16 |
| Thu. | 17 | 18 | 19 | 20 |
| Fri. | 21 | 22 | 23 | 24 |
| Sat. | 25 | 26 | 27 | 28 |

"You can't go wrong with any 'Jeist' song"



THE TWIN CITIES

Progressive Business Conditions Start the New Year Right—Dealers Put Full Faith in Future of Industry and Plan Accordingly

MINNEAPOLIS and ST. PAUL, MINN., January 3.—All the hopes of the talking machine dealers of the Northwest are centered in the infant year, 1923. They are not prone to criticizing the dead, but Old Man 1922 was somewhat disappointing. The fault may not have been all his, as the prophets possibly promised the business world more than could reasonably have been expected after the financial, commercial and industrial dislocation following the war. But 1923 should see the last barriers to normal conditions removed. Anyway, the past already is forgotten and only the future holds any interest.

As an indication of the belief in the future, William A. Lucker, who has controlled the Minnesota Phonograph Co. in St. Paul, has opened another store in that city under the name "The Edison Shop," at 27 East Seventh street, the popular retail street of the State capital. Edison business in the retail lines has been highly satisfactory in both cities and the year's record, thanks to the fine and strong demand in December, will surpass the previous year's figures. The wholesale distribution conducted by Laurence A. Lucker has shown excellent returns and testifies that the Edison will continue to stand in the foremost rank of favorite instruments.

Columbia machines are selling so rapidly in the Northwestern country that the distributing headquarters in Minneapolis have run out of style E, the \$85 machine, as well as several of the smaller types. This may not be as serious now as at some other times as the country dealers are not expected to order very heavily for some months. The year closed with a fine run of orders for December and, on the whole, must be considered as satisfactory. H. L. Pratt, manager of the branch service division of the Columbia organization, spent two days in Minneapolis toward the end of December and complimented Manager W. L. Sprague on his showing for the year.

Stock taking was interesting Manager Munson, of the Stone Piano Co., Northwestern distributor for the Aeolian-Vocalion and Vocalion Red records, when The World correspondent made the customary visit. The net results of the year appeared to be generally profitable. Both the Vocalions and the Red records are better known and stand higher in the public estimation than they did a year ago, and this is the direct result of the consistent advertising done by the Stone Piano Co. These goods are taking well in the country districts as well as in the three large cities and Vocalion shops are becoming standard places of business in the several communities of the great Northwest.

"The biggest month in our history," is the characterization given by George M. Nye, manager of the phonograph department of the Northwestern branch of the Brunswick-Balke-Collender Co., in describing December, 1922. The several Brunswick shops in St. Paul and Minneapolis have shown almost phenomenal increases in business.

Victor dealers, of whom there are scores in the Twin Cities and hundreds throughout the Northwestern section, are reasonably well satisfied with results in view of the financial and economic status of the agricultural interests.

BANQUET OF GRANBY FORCES

On December 19 the twelve New York employes of the Granby Phonograph Corp. met at a banquet given at Guffanti's restaurant. During the course of the evening addresses were made by O. P. Graffen, New York sales manager of the Granby Corp., and C. P. Chew, special sales representative. Both expressed confidence in the prospects for 1923 and urged all to cooperate toward putting Granby across in big style this year.

However, business discussion was only part of the program. Everybody was out for a good time, and, according to Mr. Graffen, this main object of the gathering was attained.

"It is this get-together spirit of the Granby forces that helps everybody work together and operates eventually to the benefit of the Granby dealers," said Mr. Graffen after the banquet.

NORMAN SMITH WITH OKEH FORCES

CHICAGO, ILL., January 6.—Norman Smith, who for the past three years has been assistant manager of the Columbia Graphophone Co.'s branch in this city, resigned from the company's service last week to join the forces of the General Phonograph Corp. of New York. Mr. Smith, who was identified with the Columbia organization for many years, is well known to the trade in many of the leading cities, and within the next few weeks his future plans with the Okeh organization will be announced.

VICTOR JOBBER CHANGES NAME

MINNEAPOLIS, MINN., January 8.—The firm name of the Beckwith-O'Neill Co., well-known Victor wholesaler of this city, has been changed to the George C. Beckwith Co., following the recent retirement of E. F. O'Neill and the appointment of Charles K. Bennett as general manager. Mr. Beckwith continues as president and treasurer and Mr. Bennett is secretary.

TWO NEW EMERSON BRANCHES

Emerson Phonograph Co. Arranges for Branches in Boston and Philadelphia—George Rosen and Harry Fox Made Managers

The Emerson Phonograph Co., manufacturer of Emerson phonographs and records, 100 West Twentieth street, New York City, has completed arrangements for the establishment of branches in Boston and Philadelphia, under the management of George Rosen and Harry Fox, respectively. Both Mr. Rosen and Mr. Fox are well known to the trade, the former having been connected with the Boston trade for a number of years as one of the proprietors of the Phonograph Supply Co. of New England, and the latter having been one of the first sales representatives of the Emerson Co. and one-time head of the Emerson Philadelphia Co. The Boston branch is located in spacious quarters at 27 Court street and the quarters for the Philadelphia branch are being arranged for.

KNICKERBOCKER STOCK DIVIDEND

The Knickerbocker Talking Machine Co., New York City, Victor wholesaler, declared a stock dividend of 25 per cent on December 23. It was stated by one of the officers of the company that from the date of the organization there has been only one cash dividend paid. However, it was pointed out that there were a number of stock dividends, the officers believing it a wise policy to use all their capital in the business instead of paying out dividends, thus providing additional capital for increasing the growth of the business.

GETS PUBLICITY THROUGH THEATRE

A publicity stunt which resulted in considerable valuable advertising was recently put over by A. J. Stack, Sonora dealer of New York City. Mr. Stack's store is located at 224 East Fordham road, opposite Keith's Theatre, and when he discovered that an act was to be staged here in which a phonograph was to be used he rushed over and persuaded the management that a Sonora was just the machine to make the act an outstanding success.

RECEIVER FOR NEW YORK FIRM

Phineas Lewinson has been appointed receiver of the Union Talking Machine Co., 16 Avenue B, New York City. Liabilities of the concern are estimated at \$20,000 and assets are about \$2,000. Nathan Smith is at the head of the business.

CARVED LEGS

Eight designs in gum, oak and mahogany. Prices reduced. Send for circular. Klise Mfg. Co., Grand Rapids, Mich.

WORLD'S CLASSIFIED ADVERTISING

Any member of the trade may forward to this office a "Situation" advertisement intended for this Department to occupy a space of four lines, agate measure, and it will be inserted free. Replies will also be forwarded without cost. Additional space will be at the rate of 25c. per line. If bold faced type is desired the cost of same will be 25c. per line. Rates for all other classes of advertising on application.

POSITION WANTED—Recording engineer of ability and experience desires to become associated with reliable company, now making or desiring to make records of quality. Familiar with all branches. References furnished. Address "Box 1242," care The Talking Machine World, 373 Fourth Ave., New York, N. Y.

WANTED—Salesman on commission basis to sell splendid line of phonographs and commercial pianos. Correspondence confidential. Address "Box 1243," care The Talking Machine World, 373 Fourth Ave., New York, N. Y.

WANTED—Salesmen calling on dealers everywhere in the United States to sell a high-class tone amplifier, that appeals immediately to the dealers. Liberal discount. Good commission. Write for particulars and state territory you cover. Unique Reproduction Co., Inc., 32 Union Sq., New York, N. Y. Suite 907.

WANTED—Canvasser to solicit Victrola business commission basis. Address "Box 1250," care The Talking Machine World, 373 Fourth Ave., New York, N. Y.

WANTED—Salesman calling on phonograph dealers to carry repeating device as side line. New repeater which is unquestionably the most popular one offered for sale. Send for sample and commission proposition. The Rapid Repeater Co., 226 Van Alst Ave., Long Island City, N. Y.

POSITION WANTED—Accountant. Bookkeeping done for firms without bookkeepers. Systems installed. Tax matters executed. References Victor dealers. Address "Box 1244," care The Talking Machine World, 373 Fourth Ave., New York, N. Y.

POSITION WANTED—Young man, having some selling experience in talking machine accessories, would accept position with growing retailer. Could invest later if required. Will locate any place. Address "Box 503," General Post Office, New York, N. Y.

POSITION WANTED—Recording engineer with 25 years' experience, also plating. Has own outfit open for engagement. Address "Box 1252," care The Talking Machine World, 373 Fourth Ave., New York, N. Y.

SALES REPRESENTATION

Man, prominent in the talking machine industry, desires exclusive sale representation of article which can be merchandised through the jobbers and dealers. Only replies of manufacturers considered. Address "Box 1248," care The Talking Machine World, 373 Fourth Ave., New York, N. Y.

CITY, COUNTY and STATE DISTRIBUTORS

wanted for exceptional portable construction to be followed by console model. Responsible parties only need reply to "Box 1249," care The Talking Machine World, 373 Fourth Ave., New York, N. Y.

HOMOKORD RECORDS GERMAN and STANDARD

Selections now offered at attractive prices. Special discounts in quantities. Ask for catalog. Favorite Mfg. Co., 105 East 12th St., New York, N. Y.

SPRINGS

| VICTOR | | |
|---|-----------------|------------|
| 1 1/4"x.022x18' 6" marine ends..... | No. 3014 | \$58 |
| 1 1/4"x.022x17' marine ends..... | No. 3014 | 55 |
| 1 1/4"x.022x17' bent arbor..... | No. 5362 | 57 |
| 1 1/4"x.022x13' bent arbor..... | No. 5423 | 50 |
| 1 1/4"x.022x9' bent arbor..... | No. 5427 | 42 |
| 1 1/4"x.022x9' bent each end..... | No. 6546 | 42 |
| 1"x.020x13' 6" marine ends..... | No. 2141 | 32 |
| 1"x.020x15' marine ends..... | No. 3335 | 35 |
| 1"x.020x15' bent arbor..... | No. 5304 | 38 |
| 1"x.020x15' bent each end..... | No. 6546 | 43 |
| 7/8"x.020x9' marine ends..... | No. 988 | 29 |
| COLUMBIA | | |
| 1"x.028x10' Universal..... | No. 2951 | 33 |
| 1"x.028x11' Universal..... | No. 2951 | 35 |
| 1"x.030x11' hook ends..... | No. 11 & 12 | 45 |
| 1"x11' for motor No. 1..... | No. 1 | 35 |
| HEINEMAN | | |
| 1"x.025x12' motors..... | No. 33 & 77 | 33 |
| 1 3/16"x.026x19', also Pathé..... | No. 11 & 12 | 75 |
| 1 3/16"x.026x17'..... | No. 4 | 59 |
| MEISSELBACH | | |
| 7/8"x10' motors..... | No. 9 & 10 | 29 |
| 1"x9' motors..... | No. 11 & 12 | 29 |
| 1"x16' motors..... | No. 16, 17 & 19 | 40 |
| SAAL-SILVERTONE | | |
| 1"x.027x10', rectangular hole..... | No. 144 | 42 |
| 1"x.027x13', rectangular hole..... | No. 145 | 48 |
| 1"x.027x16', rectangular hole..... | No. 146 | 58 |
| BRUNSWICK | | |
| 1"x.025x12', rect'glar hole, regular...No. 201 | No. 201 | 45 |
| 1"x.025x18', rect'glar hole, regular...No. 401 | No. 401 | 65 |
| 1"x.025x16', rect'glar hole..... | No. 401 | 68 |
| KRASBERG | | |
| 1"x12' motor 2A, pear-shape and rect. holes. | No. 11 & 12 | 49 |
| 1"x16' motor 3 and 4 on outer end..... | No. 11 & 12 | 60 |
| EDISON DISC | | |
| 1 1/4"x.028x25', regular size disc motors..... | No. 11 & 12 | 147 |
| 1"x.032x11', Standard..... | No. 11 & 12 | 55 |
| 1 5/16", Home..... | No. 11 & 12 | 70 |
| 1 5/16"x18' type A 150, old style disc..... | No. 11 & 12 | 128 |
| 1" Amberola 30-50-75..... | No. 11 & 12 | 56 |
| SMALL MOTORS | | |
| 7/8"x.023x10', marine ends, Heln. Col., etc.... | No. 11 & 12 | 29 |
| 3/4"x.025x10', marine ends, Heln. Col., etc.... | No. 11 & 12 | 27 |
| 5/8"x.020x9', marine ends..... | No. 11 & 12 | 21 |
| 1/2"x.020x9', marine ends..... | No. 11 & 12 | 18 |
| Victor Gov. springs, No. 1729..... | No. 11 & 12 | per 100 96 |
| Victor Gov. spring screws, No. 3304..... | No. 11 & 12 | per 100 92 |
| Victor Gov. halls, n/style, No. 3302..... | No. 11 & 12 | each 07 |
| Victor Gov. spring screw washer..... | No. 11 & 12 | per 100 72 |
| Columbia Gov. springs, No. 3510..... | No. 11 & 12 | per 100 95 |
| Columbia Gov. spring screws, No. 439..... | No. 11 & 12 | per 100 92 |
| Columbia Gov. spring screw washers..... | No. 11 & 12 | per 100 72 |
| Columbia Gov. hall, lead, flat and spring... | No. 11 & 12 | 08 |
| Columbia Gov. ball, new style & spring... | No. 11 & 12 | 08 |
| Turntable felts, all wool, green, 10", round. | No. 11 & 12 | 15 |
| Turntable felts, all wool, green, 12", round. | No. 11 & 12 | 18 |

TALKING MACHINE SUPPLY CO., PARK RIDGE, N.J.

WHERE IS THE MAN

who is sufficiently well acquainted with the talking machine manufacturer to cooperate with first-class mica manufacturing company, modernly organized and owning mica mines for the sale of DIAPHRAGMS for PHONOGRAPHS for the United States and Canada. Good opening for capable and energetic man. Send full details to "Box 1247," care The Talking Machine World, 373 Fourth Ave., New York, N. Y.

I WILL BUY FOR CASH

any quantity of records, talking machine parts or complete machines. What have you got? Address Box "1246," care The Talking Machine World, 373 Fourth Ave., New York, N. Y.

FOR SALE

Phono Motor tools, dies, etc. Complete equipment for manufacturing of high class 1-2-3 spring motor, tone arm and other cabinet hardware. Perfect condition. Could not be duplicated for \$50,000. Best offer takes. C. B. Emmert, 1370 Greenleaf Ave., Chicago, Ill.

FOR SALE

Exclusive Victor shop in Westwood, N. J. For particulars consult M. Beppler, Dumont, N. J.

POSITION WANTED—Store and sales manager, young man, 28, thoroughly experienced in every phase of music business. Own factory and stores 7 years. Desires connection. Address "Box 1251," care The Talking Machine World, 373 Fourth Ave., New York, N. Y.

Can You Use an Experienced Phonograph Advertising Manager?

Five years' experience in every phase of phonograph advertising as Advertising Manager Pathé Frères Phonograph Co., Landay Bros., New York, S. B. Davega, New York. I can bring an intimate knowledge of the phonograph dealer's selling and advertising problems. I can prepare the kind of helps he will use and the kind of copy that the consumer will read and respond to. Available on short notice. H. A. Harris, 51 West Eleventh street, New York, N. Y., or phone Stuyvesant 7300.

BEST OFFER TAKES

overstock of 3,273 Bubble Books, assorted Nos. 1 to 9 98 Repeater Stops. Manufactured by Repeater Stop Co., Chicago, Ill. 8,000 Heavy White Ogden Stock and Sales System Envelopes. Manufactured by Ogden Sec. Record System, Lynchburg, Va. for immediate delivery. All guaranteed to be absolutely new and in A-1 condition. Will sell complete or as separate units. Must close out at once. Address "Box 1245," care The Talking Machine World, 373 Fourth Ave., New York, N. Y.

SALESMAN WANTED

Salesman traveling established territory, calling on talking machine and drug trades, can make large additional income through large initial commission and commission on repeat orders. No bulky samples required. Greatest line of semi-permanent needles on the market. Made by one of oldest, time-tried and proven concerns affiliated with phonograph industry from its inception. When replying state territory covered and period of time traveled. Address "Box 1241," care The Talking Machine World, 373 Fourth Ave., New York, N. Y.

WONDERFUL OPPORTUNITY

FOR SALE—Strictly modern three-story brick factory, steam heat, fire sprinklers, finely equipped, 500 ft. R. R. siding. Now used for manufacturing phonographs. Suitable for making light furniture. Factory in continual operation. Fine labor market. Machinery, equipment and going phonograph business can be purchased with factory or separate. Full particulars address The Houghton Mfg. Co., Marion, Ohio.

STANDARD RECORDS

Thousands of records of leading make. In assorted lots of 100 — 18 cents. FAVORITE MFG. CO., 105 East 12th St., New York, N. Y.

WANTED

Standard talking machines. Will pay cash for new or used instruments. Address "Box 1254," care The Talking Machine World, 373 Fourth Ave., New York, N. Y.

CABINETS WANTED

Will be interested in communicating with cabinet manufacturers who can produce mahogany cabinets in good-sized quantities. Send specifications and prices. "Box 1253," Care The Talking Machine World, 373 Fourth Ave., New York, N. Y.



EUROPEAN HEADQUARTERS

2 GRESHAM BLDG., BASINGHALL ST., E.C. LONDON

W. LIONEL STURDY, MANAGER

Excellent Holiday Business—Pemberton Billing Home From the States—Review of Last Year's Business—Arrange for Music Exhibits at British Industries Fair—Continental Firm Boosts Capital—The Kodisk in London—Passing of H. B. Dicken and F. Sharman—Peter Pan Gramophone—News of Month

LONDON, E. C., December 30.—As I write, every section of the trade is enjoying itself hugely. Just according to expectations, for, as we appraise it, gaiety and trade these days go hand in hand. Never was such a time—we say it every year—and mean it, too! During Christmas week a round of trade visits puts one in good heart, contributory as it were to a full appreciation of the smiling atmosphere in which everyone concerned bends to the task of completing all orders "in time." Fraught with a world of meaning are those words. Dealers waiting in small queues on the jobbers, the jobbers worrying manufacturers, and they in turn speeding up their factory staffs—all in an endeavor to satisfy the insistent demand for delivery of goods "in time." Well, there may have been a few disappointments, but as usual retailers must hold the blame for delay in placement of orders. Such a rush during the last week; a storm of applications on the last day, naturally ending in a little confusion and general bewilderment! Well, it is over. And now, in the first month of the new year, we settle down to the steady jog-trot of business and perhaps register a vow to turn over a new leaf of enterprise, determined upon the exertion of every ounce of endeavor that will carry us a step further toward the goal of progressive achievement.

P. Billing Home From the States

After a five weeks' visit to New York Pemberton Billing reached home December 5. In the course of an interview at the Piccadilly office of World Record, Ltd., P. B. descanted upon the interesting nature of his trip and the good reception accorded his long-playing World record and the controller by which it is usable on any disc machine. Mr. Billing said: "I think I saw most of the leading men in the talking machine trade over there and they evinced great interest in what I had to show them. Thanks to your articles in The Talking Machine World I found that American gramophone men knew a lot about the World record and controller. Some of the technical men who were much impressed had seemingly prejudged my inventions as more in the nature of laboratory experiments than practical achievement, but actual demon-

strations on various machines soon convinced them of the soundness of the proposition."

Queried as to whether anything definite had been arranged regarding the manufacture of his patents or their sale on your side Mr. Billing stated that negotiations were proceeding with certain firms for sale of the American rights and failing fruition his company was prepared to market the goods, believing the American field offered huge and promising scope for their sale.

The State of Business in 1922

For the British gramophone trade the past year has not been one of unalloyed blessing. Nineteen hundred and twenty-two went out to the accompaniment of tremendous sales, both in machines and records, but taking the whole year through trade was exceedingly patchy—good at times; generally poor.

With the registered and unregistered unemployed totaling nearly 2,000,000 (part-timers excluded), it will be appreciated that great hardship and actual want have prevailed. The effect upon trade is too obviously demoralizing to detail. Against such adverse conditions has the trade struggled manfully, and, in a sense, successfully. Though the sum total of it all is not great, the fine spirit displayed by every section of the trade augurs well for the future, be that ever so difficult.

The British Industries Fair

The Federation of British Music Industries has supervised and completed arrangements respecting the music section of the above exhibition which opens its doors next month at the White City, Shepherd Bush, London. A separate committee for each section of the trade will look after the interests of exhibitors, of whom there are close upon fifty, at least fourteen being purely gramophone firms. General rules and regulations have been laid down for the guidance and observance of music exhibitors to which doubtless all will conform.

While there is nothing definite to go upon it is believed that this year's fair offers better prospects of satisfactory business than the last. Certainly the music exhibits are more numerous, and being thoroughly representative of all departments of British musical products should attract a goodly number of visitors from overseas.

News From the Continent

According to the Frankfurter Zeitung the Polyphonwerke plans an increase of its capital from forty-two to seventy-five million marks. The object in view is the development of its establishment owing to the fact of present

monthly turnover exceeding the share capital. An increased dividend for the current fiscal year is expected.

All sections of the music trade are expected to participate in the first French Music Salon to be held in Paris May 10 to 25.

An exhibition is also to be held in Barcelona, Spain, some time during May or June and foreign manufacturers of pianos and gramophones are invited to exhibit their wares.

The Kodisk in London

Described as the greatest gramophone novelty of the year—it is certainly unique—the Kodisk self-recording record disc has made its appearance on this market. All anticipations point to a big demand from gramophone users on this side. This is very likely to materialize since the Kodisk meets an undoubted long-felt want in the absence here of any kind of home-recording device.

"His Master's Voice" News

A new instrument catalog for 1922-23 has been issued by the Gramophone Co., Ltd. It illustrates all models and with descriptive matter and prices represents a complete guide to comprehensive service provided by this firm.

The big London store of Harrods is very up to date. Its music department carries a complete range of H. M. V. instruments and records and many are the excellent sales schemes which Manager E. H. Aird is continually devising. One of the best is the engagement of leading exponents of the terpsichorean art who give exhibitions of the latest dances accompanied by H. M. V. records. For this purpose Harrods have erected a magnificent stage with a special dancing floor. In addition to the provision of over four hundred seats there is standing accommodation for three hundred persons, and usually the place is crowded with enthusiastic followers of Terpsichore.

Wonderful success has attended the H. M. V. Sales School. I am informed that during its nine months' existence some hundreds of dealers and their assistants have taken the full course of salesmanship, specialized lectures, etc., by sales experts. The courses recommence on March 5, 1923, and already a number of dealers have booked dates of attendance.

My reference in the November issue to "occasional" H. M. V. lectures on the educational value of the gramophone brings me a reminder from W. Manson that his company has under constant engagement no less than three highly specialized lecturers whose educational work throughout chief centers of the country is laying a solid foundation of increasing recognition

EDISON BELL

WINNER

TRADE MARK

GRAMOPHONE RECORDS

CABLE
"PHONOKINO,
LONDON"

ARE THE GREATEST VALUE FOR MONEY PRODUCED IN GREAT BRITAIN

TEN INCH DOUBLE SIDED NEEDLE CUT

PLAY ON ALL GRAMOPHONES

Catalogue contains 4000 Titles by the Premier Artistes, Instrumentalists, Orchestras and Bands of the British Empire

DEALERS PREPARED TO DO BUSINESS ARE INVITED TO COMMUNICATE WITH

Proprietors and Manufacturers, J. E. HOUGH, Ltd., 62 Glengall Road, London, S. E. 15, England

FROM OUR LONDON HEADQUARTERS—(Continued from page 150)

of the versatility and value of the gramophone in all departments of education. In this respect "His Master's Voice" occupies a pioneer place among gramophone companies and the good work accomplished radiates its influence to the benefit of the whole trade. Another time it will be my pleasure to enlarge upon the scope of "His Master's Voice" activity.

Obituary—H. B. Dicken and F. Sharman

It is with extreme regret that I have to record the deaths of these two gentlemen. H. B. Dicken was editor of the journal published by the Federation of British Music Industries and director of the newspaper propaganda department of the Federation. His work proved of the utmost value and assistance to the whole trade and it is true to say that his loss will be keenly felt by all who knew genial Dicken. Hail fellow well met, his was a kindly personality and in common with the trade I mourn the passing of a journalistic comrade at the comparatively early age of fifty-two years.

Early on the same day I received the sad news of the passing of F. Sharman, managing director of the Rowhill Engineering Co., Enfield Town, in his seventy-third year. He was one of the grand old men of the gramophone trade, robust in manner yet ever kindly and courteous. Well known in trade circles, many will keenly regret that he is no longer with us, and on their behalf I couple with my own personal condolence an expression of hearty sympathy with his family. The deceased's son, Mr. F. Sharman, will, I understand, carry on the Rowhill Engineering Co. at the old address.

The Smallest Gramophone

In size about six by seven by five inches, the Peter Pan gramophone just introduced here is probably the smallest known. Its appearance is so much like a camera that at short distance one could scarcely tell the difference. It is not a toy, for it has sufficient motor power to play through a twelve-inch record. The turntable consists of four arms, which fold in when not in use, while a ten-inch length of trumpet is secured by means of an aluminum collapsible arrangement which fulfills its function quite well. The Peter Pan retails at £3, 7s., 6d.

Columbia Co. Now All British

The Columbia Graphophone Co., Ltd., has is-

sued from its London headquarters office the important advice that it is now wholly a British concern. Until recently part of the holdings had been in the hands of the Columbia Co., of New York, but the shares so held have been acquired by British interests, with the result that in this country Columbia "is entirely free of any American control or interests and exclusively British in ownership." The report continues: "This independence will not, however, deprive the British company of the advantages of the most friendly relationship with the American house, and Columbia in Great Britain will still enjoy the benefits of any improvements effected in the U. S. A., no small matter when it is remembered that to that country we owe the invention of the talking machine itself and much of its subsequent development."

OUR EXPORTS OF TALKING MACHINES

Exports and Imports of Talking Machines and Records Show Decreasing Tendency as Compared With Last Year—Our Buyers Abroad

WASHINGTON, D. C., January 10.—In the summary of exports and imports of the commerce of the United States for the month of September, 1922 (the latest period for which it has been compiled), which has just been issued, the following are the figures on talking machines and records:

The dutiable imports of talking machines and parts during September, 1922, amounted in value to \$24,375, as compared with \$41,729 worth which were imported during the same month of 1921. The nine months' total ending September, 1922, showed importations valued at \$377,463, as compared with \$462,752 worth of talking machines and parts during the same period of 1921.

Talking machines to the number of 5,532, valued at \$199,110, were exported in October, 1922, as compared with 1,977 talking machines, valued at \$91,893, sent abroad in the same period of 1921. The nine months' total showed that we exported 36,433 talking machines, valued at \$1,292,560, as against 26,974 talking machines, valued at \$1,287,683, in 1921.

Hornless, Table Grand, Upright and Horizontal Cabinet Grands

Actual Manufacturers Export a specialty

REX GRAMOPHONE COMPANY

59 Chiswell Street, LONDON, E. C., England
Cable Address "Lyrecodisc, London"

The total exports of records and supplies for October, 1922, were valued at \$70,985, as compared with \$137,962 in October, 1921. The nine months ending October, 1922, show records and accessories exported valued at \$743,689; in 1921, \$1,646,683.

The countries to which exports were made in October and the values thereof are as follows: France, \$2,199; United Kingdom, \$5,130; Canada, \$58,993; Central America, \$6,614; Mexico, \$15,747; Cuba, \$1,348; Argentina, \$16,818; other South America, \$19,860; Chile, \$8,148; China, \$4,181; Japan, \$24,713; Philippine Islands, \$4,813; Australia, \$9,879; Peru, \$3,654; other countries, \$17,013.

COLUMBIA NEWS FROM ST. LOUIS

Several New Dealers Appointed—Publicity Producing Results—Out-of-town Visitors

St. Louis, Mo., January 8.—The Gillen Furniture Co., Blytheville, Ark., has recently become a Columbia dealer and immediately after securing the franchise this enterprising concern arranged for a newspaper campaign. This publicity has already produced splendid results and will be continued throughout 1923. Another new Columbia dealer in this territory is J. H. Kirkland, of Flat River, Mo.

The Fleming Furniture Co., Fairfield, Ill., Columbia dealer, is making alterations to its store and when completed this establishment will contain a separate Grafonola department with several new booths.

Among the recent visitors at the St. Louis branch of the Columbia Co. were G. C. Moses, of Pfeifer Bros., Little Rock, Ark.; B. W. Plummer, of the Davis Piano Co., Alton, Ill., and E. G. Gillen, of the Gillen Furniture Co., Blytheville, Ark.

You Ought to Know

In case you are contemplating expanding the sphere of your business to include departments devoted to Pianos, Player-Pianos, Musical Merchandise or Sheet Music, that you'll find news and comments about them all in



The oldest and leading music trade weekly, which covers every branch of the industry

It Contains

Instructive and educational articles. Hints on salesmanship and advertising. Editorials that are timely and authoritative. Facts about the new things in the trade. Trade happenings in all parts of the United States

"Review the Music Trade With Us"

Send your \$2 now for a full year's subscription to

THE MUSIC TRADE REVIEW
373 FOURTH AVENUE NEW YORK

LATEST PATENTS RELATING TO TALKING MACHINES AND RECORDS

WASHINGTON, D. C., January 8.—Talking Machine. Arthur W. Rivet, St. Louis, Mo. Patent No. 1,430,459.

This invention has for its object the provision of a metal throat and tone chamber attached to a metallic modulator box, the modulator box being provided internally with a slidable block whereby communication through the device may be cut off to a variable extent as may be desired. An important object is the provision of a metallic throat member, which is so constructed that it is detachably connected with

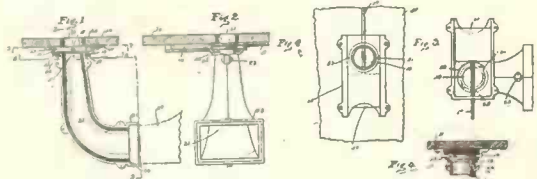

the modulator box so that it may or may not be used as preferred.

Figure 1 is a longitudinal sectional view through a talking machine showing the device applied thereto. Fig. 2 is a section at right angles to Fig. 1. Fig. 3 is a horizontal sectional view on the line 3—3 of Fig. 1. Fig. 4 is a sectional view on the line 4—4 of Fig. 1.

Repeating Mechanism for Phonographs. Lewellyn S. Woodhull, Lloyd M. Prentice and John H. Rice, Detroit, Mich., said Woodhull assignor to Prentice and Price, Milwaukee, Wis. Patent No. 1,430,780.

This invention has for its principal object the provision of means for intermittent operation by the driving motor of a phonograph, whereby the tone arm of the instrument may be caused to automatically return and repeat the rendering of a record.

Another object is to provide in such a device manually adjustable means to limit within predetermined points the effective engagement of the tone arm upon the record so as to cause said arm to traverse such selected portion of the record and repeat the rendition thereof.

A further object is to provide means for controlling the return movement of the tone arm whereby upon completion of the rendering of a record the tone arm may be returned so as to clear the record and position the needle upon a brake actuating pad to automatically stop the motor of the instrument.

Figure 1 is a plan view of a phonograph centrally broken away to show the relation of the motor and tone arm to the controlling mechanism of the present invention, the tone arm being shown in full lines in position to initiate a return movement and indicating by dashed lines the arm at rest upon the brake pad in the idle position. Fig. 2 is a side elevation of the parts

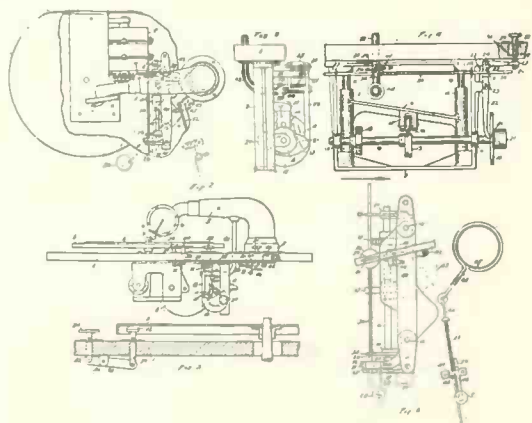

in the position shown in Fig. 1. Fig. 3 is an enlarged sectional view through the turn table and motor board showing the brake and its actuating pad in elevation. Fig. 4 is an enlarged detail in elevation of the vertically movable inclined run-way and mechanism for imparting movement thereto. Fig. 5 is an end elevation of the parts shown in Fig. 3. Fig. 6

is an enlarged plan of the repeating mechanism, as shown in Fig. 1, with the tone arm and motor of the instrument omitted.

Phonograph Machine. Gaston Strobino, Paterson, N. J. Patent No. 1,430,700.

This invention has for its principal object to provide an arrangement and construction of the system of parts that terminates in a needle or point to bear on the record-forming surface that will conduce to such a transmission of vibrations that reproduction of sound in a materially improved degree will ensue and that will further make it possible for said system of parts to be operative, when used in transmitting vibrations from such a surface, with record-grooves whose undulations are either-vertical or lateral. The principal feature of the invention consists in a transmitter characterized by an attenuated arm formed of thin material and having a thick vibratory head, and a record-groove-engaging needle or point fixedly connected to the thick head of said arm, the arm

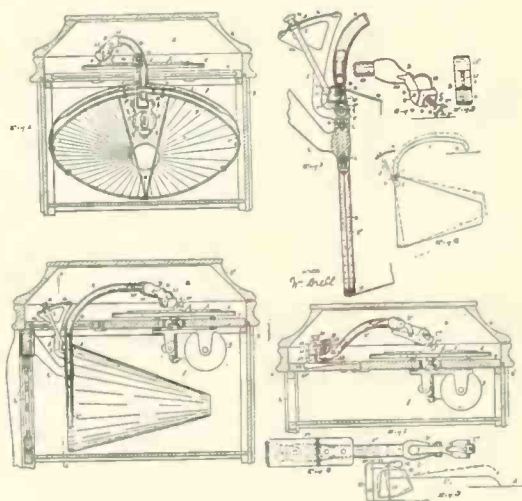

being movably connected to a fixed part of the machine. Therein are shown two forms of a machine embodying this feature of the invention; the machine shown in Figs. 1 to 6 embodies it with, and that shown in Figs. 7 to 9 embodies it without, certain other novel features which, when used with the principal feature of the invention, increase the improvement which it represents in the way of better sound reproduction that is capable in the use of the ordinary devices, and which have certain value quite independent of the principal feature.

In Figures 1 to 6, showing the first form, Fig. 1 is a front elevation, the case appearing in vertical section on line 1—1, Fig. 2. Fig. 2 is a side elevation, the case again appearing in vertical section. Fig. 3 is a vertical front-to-rear section of the principal parts; Figs. 4 and 5 are side and end elevations of the record-groove engaging end portion of the transmitter, and Fig. 6 is a diagrammatic view. In Figs. 7, 8 and 9, showing the other form, Fig. 7 is a front elevation, the case appearing in vertical section. Fig. 8 is an underneath plan of the part of the transmitter which includes the aforesaid attenuated arm and its thick head and the means to connect it to a fixed part of the machine, and Fig. 9 is a diagram illustrating this form.

Cover Support. Anthony F. Zega, Bloomfield, N. J. Patent No. 1,434,762.

This invention relates to an improved cover support adapted for holding open the lids of phonographs, trunks and similar articles, and is of the type in which, when the cover is raised from its closed position to its limit of upward movement and then released, it is held open, and from this position is simply raised a short distance and then can be lowered to its closed position, this being accomplished entirely by manipulation of the cover and requiring no individual manipulation of the support.

The invention is illustrated in the accompanying drawing, in which Figure 1 shows part of a phonograph cabinet equipped with improved form of cover support. Figure 2 is a perspective view of the supporting plate, showing the lower end of the supporting rod. Figure 3 is a

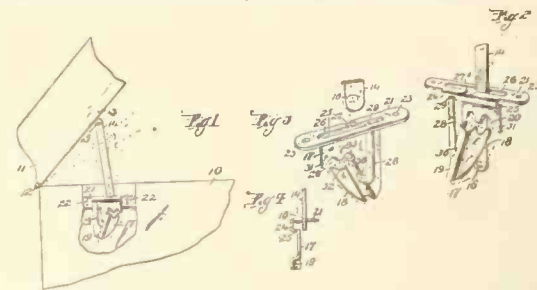

similar view showing the reverse side and illustrating a slightly modified form of channel in the supporting plate, and Figure 4 is a partial section taken on a plane indicated by line 4—4 in Figure 2.

Phonograph Record Cleaner. Arthur B. Kidder and Homer Miller, Canton, O., said Miller assignor to Henry Stolzenbach, same place. Patent No. 1,435,645.

This invention relates to phonograph record cleaners and more particularly to an attachment adapted to be carried upon the tone arm of the phonograph and provided with a cleaning pad arranged to travel upon the record ahead of the needle for brushing the record as it revolves and freeing the playing grooves therein of dust or other foreign matter before coming in contact with the needle.

Figure 1 is a side elevation showing the attachment applied to a phonograph; Fig. 2, a

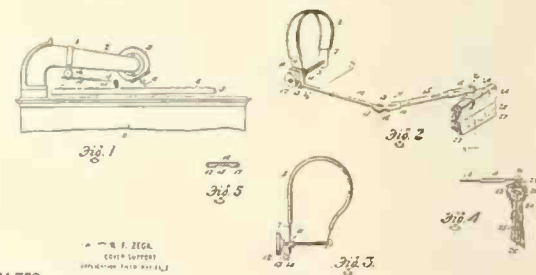

perspective view of the attachment; Fig. 3, a section on the line 3—3, Fig. 2; Fig. 4, a section on the line 4—4, Fig. 2, and Fig. 5, a section on the line 5—5, Fig. 2.

Phonograph. Walter F. Luhnaw, Oak Park, Ill. Patent No. 1,436,510.

This invention relates mainly to phonographs, and more particularly to the horn or amplifying means therefor. After investigation and experiments it has been found that in a phonograph horn or similar amplifying chamber there is in some degree a pumping action tending to urge the air in the direction of the sound, and that provision for admitting air at the small end of the horn or amplifier tends to equalize the pressure and improve the sound efficiency of the instrument.

Fig. 1 is a plan of an amplifying horn of U-shape with the reproducing attachment secured to the middle part thereof. Fig. 2 is a

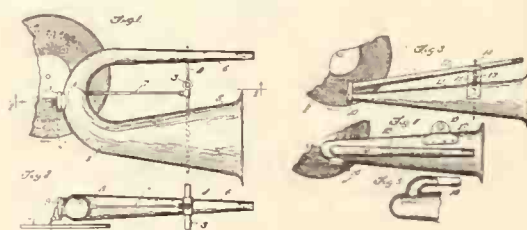

central vertical section through the reproducer and adjacent part of the amplifying horn at 2—2 on Fig. 1. Fig. 3 is a plan of a reproducer having attached thereto a pair of complementary amplifying members, one of which is horn-shaped for emitting the sound, and the other of which is relatively small and nearly tubular

PATENTS RELATING TO TALKING MACHINES AND RECORDS—(Continued from page 152)

in shape for equalizing the pressure back of the diaphragm. Fig. 4 is a plan of another embodiment in which the main amplifying horn is provided with an upward equalizing arm. Fig. 5 is a fragmentary section at 5—5 on Fig. 4.

Phonograph. Edwin A. Watson, Mill Valley, Cal. Patent No. 1,436,129.

The present invention relates to improvements in sound reproducing machines and its principal object is to provide a machine of the character described that automatically begins to operate when the record is placed on its seat and that automatically stops when the last groove of the record has been reached. A further object of the invention is to provide a mechanism by which the sounder carrying the needle automatically finds its right place for records of different sizes. Another object is to provide a sounder that will bring the needle into operative contact with the first groove of the record only after the record has made a number of turns and has acquired its full speed. Various other objects and advantages of the machine will appear as the description proceeds.

Figure 1 represents a side view of the principal working parts of the sound reproducing

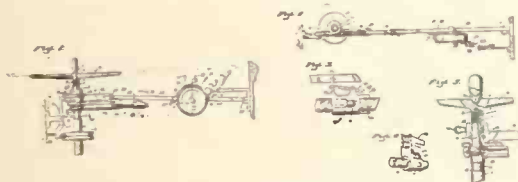

machine; Figure 2, a sectional view through the same along line 2—2 of Figure 1; Figure 3, an enlarged detail side elevation of a sleeve traveling on a revolving rod; Figure 4, a perspective view of the mechanism shown in Figure 3, and Figure 5 an enlarged detail view, partly in section, showing the main shaft and the parts associated with the same.

Continuous Player for Talking Machines. Adrian Clifford Balson, Philadelphia, Pa. Patent No. 1,436,004.

This invention relates to improvements in a continuous player device for talking machines in which alternating sound boxes and needles operate in conjunction, with a supporting tube with a number of collars or sleeves thereon, needles and sound boxes being caused to engage alternately the talking machine record by means of a counter-balancing weight, the movement of which is controlled by a circular governor placed on the center of the record. The objects of the invention are first to provide a needle continuously in contact with the talking machine record; second, to afford facilities for the proper adjustment of the device whereby records of different diameters may be played by a continuous talking machine player; third to provide means whereby a trigger pin upon its coming in contact with the beveled edge of circular governor when the record is entirely played, will throw the counter-balancing weight over, thereby lifting the needle of one sound box off the record and placing the needle of the other sound box upon the record at the beginning thereof.

Figure 1 is a front view of the machine. Fig. 2 is a view of the machine as it appears looking down upon it with the tone arm broken off. Fig. 3 is a side view of the machine looking

towards the center of the record with one needle in play and the trigger pin about to throw the counter-balancing weight, lifting the needle from the record. Fig. 4 is a view of the circular governor looking directly down upon

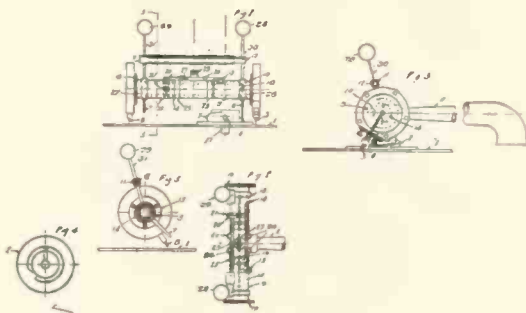

it, which is placed in the center of the record and regulates the movement of the counter-balancing weight. Fig. 5 is a side view of the other sound box looking from the center of the record outward with the needle not in play.

Sound Amplifying and Reproducing Apparatus. Charles Blieberger, New York. Patent No. 1,436,080.

This invention relates generally to apparatus for amplifying and reproducing sounds caused by a vibratory diaphragm, as in a phonograph, telephone, and other acoustic devices. The object of the invention is to produce an apparatus of compact proportions and capable of reproducing sounds with a marked degree of amplification, clearness and naturalness.

Figure 1 is a perspective view of a sound amplifier containing the invention; Fig. 2 is an inside view showing the various sound compartments; Fig. 3 is a vertical cross-section taken approximately on line 3—3 of Fig. 2; Fig. 4 is a detached perspective view of the sound-receiving and sound-distributing compartments; Fig. 5 shows the inside of a modified form of apparatus constructed in accordance with the invention; Fig. 6 is a vertical cross-section taken approximately on line 6—6 of

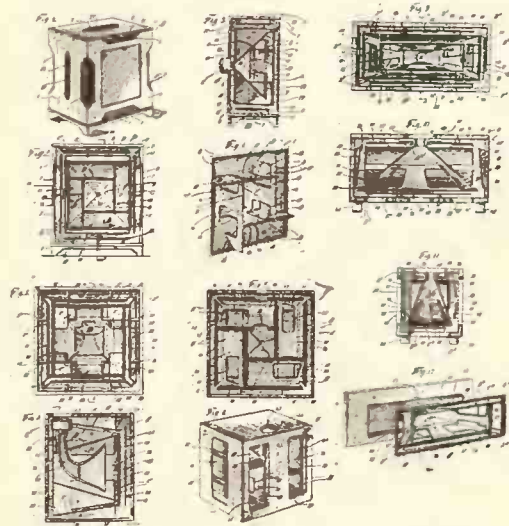

Fig. 5; Fig. 7 is a sectional view taken approximately on line 7—7 of Fig. 6; Fig. 8 is a perspective view of the outer box or cabinet shown in Figs. 5, 6 and 7; Fig. 9 shows the inside of a small elongated box embodying the invention; Fig. 10 is a longitudinal cross-section approximately on line 10—10 of Fig. 9; Fig. 11 is a transverse cross-section approximately on line 11—11 of Fig. 9; and Fig. 12 is a perspective view of the pyramidal compartments shown in Figs. 9, 10 and 11.

Repeating Attachment for Disc Record Phonographs. Stanley S. Johns, Baltimore, Md. Patent No. 1,438,116.

This invention relates to improvements in repeating attachments for disc records on disc phonographs. In the use of such instruments it is often desirable to provide an automatic repetition arrangement whereby the instrument may be caused to play continuously, or as long as the turn-table continues to revolve, without the necessity of moving the needle back by hand with the consequent interruption in the music. Such devices are especially useful where these

instruments are used to provide music for dancing.

Figure 1 shows a plan view of the parts in the assembled relation, with the needle and the tone arm in the playing position, and the stop bar extending over the disc in the operative position. Fig. 2 is an enlarged side elevation of the reproducer and the parts carried thereby, including the needle and its attachments, as seen from the left of Fig. 1, the needle being in the playing position with regard to the disc. Fig. 3 is a similar view to Fig. 2, but shows the needle out of engagement with the disc, and the resetting cam in the position for restoring the tone arm to the initial position. Fig. 4 is a plan view, partly in section along the broken line 4—4, of the apparatus shown in Fig. 2. Fig. 5 shows a vertical section along the line 5—5 of Fig. 2, and looking in the direction of the arrows, parts being shown in elevation. Fig. 6 shows a section along the line 6—6 of Fig. 2, the resetting cam and diagonal roller being shown in plan, and the parts being shown on a larger scale than in Fig. 2. Fig. 7 shows a section along the line 7—7 of Fig. 3, and looking down, the parts being shown on a larger scale than in Fig. 3, and the resetting cam being

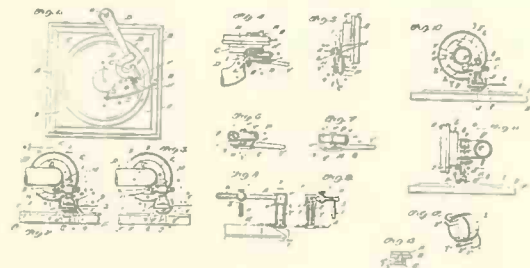

shown in plan. Fig. 8 is a detail view, on a larger scale, of the pivot end of the stop bar. Fig. 9 shows a section along the broken line 9—9 of Fig. 8, and looking in the direction of the arrows. Fig. 10 shows a modified form of attachment for use with the operating cam, the same showing a section along the line 10—10 of Fig. 11. Fig. 11 represents the device shown in Fig. 10 as seen from the left of said figure. Fig. 12 is a detail perspective view of the clamping ring shown in Figs. 10 and 11; and Fig. 13 is an enlarged sectional elevation of the friction bearing for the tripping lever.

Sound Amplifier for Talking Machines. Lena Belle Prout, Morland, Kansas. Patent No. 1,437,677.

This invention is an improvement in those sound amplifiers for talking machines which are used in connection with sound recording and reproducing machines.

The object of the invention is to provide sound amplifiers for talking machines with an improved construction of lining which will eliminate all harsh, metallic and unnatural sounds which occur in existing types of sound amplifiers, of sound recording and reproducing machines.

Figure 1 is a perspective view of a modern form of talking machine, the doors of the tone chamber being open and showing the improved

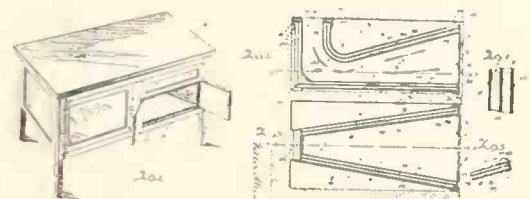

sound amplifier located within the tone chamber thereof; Fig. 2 is a vertical section taken on the line 2—2 of Fig. 3 looking in the direction of the arrows. Fig. 3 is a horizontal section taken on the line 3—3 of Fig. 2 looking in the direction of the arrows. Fig. 4 is a detail transverse section on a larger scale of the improved amplifier having layers of wood material arranged with the grain thereof crossed. Fig. 5 is a detail longitudinal section of the lining showing a modification in the construction of the extended covering for the solid layers.

REPAIRS

All Makes of Talking Machines
Repaired Promptly and Efficiently
REPAIR PARTS FOR ALL MACHINES

ANDREW H. DODIN

25 Sixth Avenue New York
TELEPHONE, SPRING 1194

Advance RECORD BULLETINS for February, 1923

VICTOR TALKING MACHINE CO.

- POPULAR SONGS**
- 18991 Jimbo Jambo.....Billy Murray 10
 I Was Married Up in the Air....Billy Murray 10
 18990 Will She Come from the East?.....John Steel 10
 Lady of the Evening.....John Steel 10
- DANCE RECORDS**
- 18985 When Hearts are Young—Fox-trot,
 Paul Whiteman and His Orch. 10
 Journey's End—Fox-trot,
 Paul Whiteman and His Orch. 10
 18986 Lost (A Wonderful Girl)—Fox-trot,
 The Great White Way Orch. 10
 Where the Bamboo Babies Grow—Fox-trot,
 The Virginians 10
 18988 Until My Luck Comes Rolling Along—Fox-trot,
 Paul Whiteman and His Orch. 10
 Just Like a Doll—Fox-trot,
 Paul Whiteman and His Orch. 10
 18992 Teddy Bear Blues—Fox-trot...The Virginians 10
 I'm All Alone—Fox-trot,
 The Great White Way Orch. 10
 18993 Who Cares—Fox-trot,
 The Great White Way Orch. 10
 Time Will Tell—Medley Fox-trot,
 The Great White Way Orch. 10
 18994 I'm Through—Fox-trot,
 The Benson Orchestra of Chicago 10
 Open Your Arms, My Alabamy—Fox-trot,
 Zez Confrey and His Orch. 10
 18995 My Buddy—Fox-trot,
 International Novelty Orch. 10
 When Winter Comes—Fox-trot,
 The Great White Way Orch. 10
 18996 Thru' the Night—Waltz.....The Serenaders 10
 Red Moon—Waltz.....The Serenaders 10
- VOCAL AND INSTRUMENTAL RECORDS**
- 45342 Mah Lindy Lou.....Olive Kline 10
 Honey Chile.....Elsie Baker 10
 18984 The Son of God Goes Forth to War,
 Trinity Male Choir 10
 O Paradise.....Trinity Male Choir 10
 45341 A Heap o' Livin' (Recitation).....Edgar Guest 10
 The Boy and the Flag and At the Door (Recita-
 tion).....Edgar Guest 10
 45330 Spring Song.....Alberto Salvi 10
 Ballad of the North—Finale.....Alberto Salvi 10
 18974 Toy Symphony—Andante Moderato (Haydn),
 Victor Concert Orch. 10
 Toy Symphony—Menuetto and Finale (Haydn),
 Victor Concert Orch. 10
 35719 Faust—Ballet Music, Cleopatra and the Golden
 Cup (Gounod).....Victor Symphony Orch. 12
 Faust—Ballet Music, Dance of Cleopatra and
 Her Slaves (Gounod).....Victor Symphony Orch. 12
 18987 I'll Take You Home Again, Kathleen,
 Michel Gusikoff 10
 Mollie Darling.....Michel Gusikoff 10
 18989 My Old Hawaiian Home—Waltz,
 Sam Moore-Horace Davis 10
 Isle of Sweethearts—Waltz,
 Sam Moore-Horace Davis 10
- RED SEAL RECORDS**
- SOPHIE BRASLAU, Contralto
 66115 Some Day You Will Miss Me.....Grey-Darewski 10
 FEODOR CHALIAPIN, Bass—In Italian
 87355 Mefistofele—Ave, Signor! (Hail, Sovereign
 Lord).....Boito 10
- FLONZALEY QUARTET
 74792 Quartet in D Major—Presto.....Beethoven 12
 JASCHA HEIFETZ, Violinist
 (Piano accompaniment, Sam Chotzinoff)
 66123 Hungarian Dance, No. 1, in G Minor...Brahms 10
 TITTA RUFFO, Baritone—In Italian
 87352 Martha—Porter Song (Canzone del Porter),
 Flotow 10
- OLGA SAMAROFF, Pianist
 74794 La Campanella (The Chimes)....Paganini-Liszt 12
 TITO SCHIPA, Tenor—In Neapolitan
 66117 Chi se nne scorda echiu' (Oh, How Can I
 Forget).....Marvasi-Barthelemy 10
 ARTURO TOSCANINI AND LA SCALA ORCHESTRA
 74769 Symphony in C Minor, No. 5—Finale, Part 1,
 Beethoven 12
 74770 Symphony in C Minor, No. 5—Finale, Part 2,
 Beethoven 12
- REINALD WERRENATH, Baritone
 66118 Little Man.....Graf-Ball 10
 EFREM ZIMBALIST, Violinist
 66119 Song Without Words (Chant sans paroles),
 Tchaikowsky 10
- The following number has been re-listed in the Victor
 Supplement by special request.
 ERNESTINE SCHUMANN-HEINK, Contralto
 87353 Cradle Song.....Brahms 10

COLUMBIA GRAPHOPHONE CO.

- SYMPHONY RECORDS**
- A3747 Deep in Your Eyes (Jacobi)—Soprano Solo,
 Margaret Romaine 10
 I Passed by Your Window (Brahe)—Soprano
 Solo.....Margaret Romaine 10
 98045 Romeo and Juliet—"Ab! Lève-toi soleil" (Fair-
 est Sun, Arise). (Gounod)—Tenor Solo,
 Charles Hackett 12
 49935 Home, Sweet Home (Bishop)—Soprano Solo,
 Rosa Ponselle 12
 98044 Dreams of Long Ago (Caruso)—Tenor Solo,
 Tandy Mackenzie 12
- A3749 Sweet and Low (Barnby)—Soprano Solo and
 Male Quartet...Lucy Gates and Male Quartet 10
 Chiming Bells of Long Ago (Shattuck)—
 Soprano Solo and Male Quartet,
 Lucy Gates and Male Quartet 10
- A6225 Golondron from Maruxa (Vives)—Bass Solo,
 Jose Mardones 12
 Mefistofele Prologo—Ava Signor (Hail, Lord!)
 (Boito)—Bass Solo.....Jose Mardones 12
 98046 Angel's Serenade (Braga-Pollitzer)—Violin Solo,
 Toscha Seidel 12
- A3748 Drifting Down (Hackleman)—Male Quartet,
 Criterion Quartet 10
 Sometime, Somewhere (Spoonster)—Male Quartet,
 Criterion Quartet 10
- A3750 The Last Rose of Summer. Intro. "Believe
 Me If All Those Endearing Young Charms."
 —(Moore)...Handsaw and Harp-Guitar Duet,
 Moore and Davis 10
 Old Black Joe (Foster) Handsaw and Harp-
 Guitar Duet.....Moore and Davis 10
- A3751 Crinoline Days. Intro. "Will She Come from
 the East?" (from "Irving Berlin's Music Box
 Revue")—Medley Fox-trot...The Columbians 10

- Pack up Your Sins and go to the Devil. Intro.
 "Bring on the Pepper," (from "Irving Berlin's
 Music Box Revue") (Berlin)—Medley
 Fox-trot.....The Columbians 10
- A3760 When Hearts Are Young (Romberg & Good-
 man). Intro. "Marianna" (Gilbert), (from
 "The Lady in Ermine")—Medley Fox-trot,
 Paul Specht and His Orch. 10
 I Still Can Dream. Intro. "In the Starlight,"
 (from "The Yankee Princess") (Kalman)—
 Medley Fox-trot...Paul Specht and His Orch. 10
- A3759 Away Down East In Maine (Donaldson)—
 Fox-trot.....Paul Specht and His Orch. 10
 One Night In June (Snyder, Lange and Klap-
 holz)—Fox-trot...Paul Specht and His Orch. 10
- A3764 Ivy (Johnson and Jones)—Fox-trot,
 Yerkes' S. S. Flotilla Orch. 10
 Dumbell (Confrey)—Fox-trot...The Happy Six 10
 A3752 Call Me Back Pal o' Mine. Intro. "He Was
 a Pal o' Mine." (Dixon)—Medley Waltz,
 Columbia Dance Orch. 10
 Save the Last Waltz For Me. Intro. "Lover's
 Lane with You," (from "Sue Dear") (John-
 son and Austin)—Medley Waltz,
 Columbia Dance Orch. 10
- A3757 Lovin' Sam (The Sheik of Alabam') (Ager),
 Nora Bayes, Comedienne 10
 Daddy's Goin' Huntin' Tonight (Myers),
 Nora Bayes, Comedienne 10
- A3758 Hot Lips (Busse, Lange, Davis),
 Dolly Kay, Comedienne 10
 Blue (Handman).....Dolly Kay, Comedienne 10
- A3762 You Gave Me Your Heart (Snyder)—Tenor
 Solo.....Edwin Dale 10
 A Picture Without a Frame (Von Tilzer)—
 Tenor Solo.....Edwin Dale 10
- A3763 Carolina Mammy (James)—Male Quartet,
 Shannon Four 10
 Open Your Arms My Alabamy (Meyer)—Male
 Quartet.....Shannon Four 10
- A3746 Evil Blues (Bradford),
 Edith Wilson and Johnny Dunn's Original
 Jazz Hounds, Comedienne and Jazz Band 10
 Pensacola Blues (Home Again Croon),
 Edith Wilson and Johnny Dunn's Original
 Jazz Hounds, Comedienne and Jazz Band 10
- A3754 Sophie, (from "Make It Snappy.") (Silver),
 Eddie Cantor, Comedian 10
 He Loves It (Wendling),
 Eddie Cantor, Comedian 10
- MID-MONTH LIST**
- A3755 Carry Me Back to My Carolina Home (Silver)
 —Fox-trot...Frank Westphal and His Orch. 10
 Those Star Spangled Nights in Dixieland (Can-
 tor, Ruby and Wendling)—Fox-trot,
 Frank Westphal and His Orch. 10
- A3756 Vamp Me (Gay)—Fox-trot...Paul Biese's Orch. 10
 To-morrow (Will Be Brighter Than Today)
 (Owens and Halstead)—Fox-trot,
 Paul Biese's Orch. 10
- A3751 Blue (Handman)—Fox-trot...Eddie Elkins' Orch. 10
 Who Cares? (Ager)—Fox-trot,
 Eddie Elkins' Orch. 10
- A3753 Georgia Cabin Door (Young and Squires),
 Van and Schenck, Comedians 10
 Kentucky Echoes (Gilbert and Reilly),
 Van and Schenck, Comedians 10

AEOLIAN CO.

- VOCALION RECORDS**
- OPERATIC SELECTIONS**
- 52044 O Paradiso (From "L' Africana") (Meyerbeer)
 —Tenor—Aeolian Orch. Accomp.,
 Giulio Crimi 12
- INSTRUMENTAL SELECTIONS**
- 35012 William Tell Overture—Part 3 (Rossini),
 Aeolian Symphony Orch.
 Conducted by Gennaro Papi,
 Metropolitan Opera House Conductor 12
 William Tell Overture, Part 4 (Rossini),
 Aeolian Symphony Orch.
 Conducted by Gennaro Papi,
 Metropolitan Opera House Conductor 12
- 14481 Under the Double Eagle (Wagner)—March,
 Lieut. Francis W. Sutherland
 and His Seventh Regiment Band 10
 Second Regiment Connecticut March (Reeves),
 Lieut. Francis W. Sutherland
 and His Seventh Regiment Band 10
- STANDARD SELECTIONS**
- 30165 Night (Russian Folk Song)—Soprano—Aeolian
 Orch. Accomp.....Rosa Raisa 10
 30164 Tally Ho! (Levin)—Baritone—Aeolian Orch.
 Accomp.....John Charles Thomas 10
 30163 Your Voice (Macdermid)—Soprano—Aeolian
 Orch. Accomp.....Evelyn Scotney 10
- 24034 Heaven at the End of the Road (Osgood)—
 Tenor—Orch. Accomp.....Colin O'More 10
 Because of You (Solman)—Tenor—Orch.
 Accomp.....Colin O'More 10
- 14482 Ole Uncle Moon (Scott)—Unaccomp.,
 Criterion Male Quartet 10
 Mammy's Lullaby (Spross)—Unaccomp.,
 Criterion Male Quartet 10
- 14483 Davy Jones' Locker (Petrie)—Bass—Orch.
 Accomp.....Wilfred Glenn 10
 Ashtore (Trottere)—Tenor—Orch. Accomp.,
 Charles Harrison 10
- TEWISH SELECTIONS**
- 14485 Shuster Halt Sich Bei Bein Dratve (Cherniaf-
 sky)—Tenor—Orch. Accomp.....Aaron Lebedeff 10
 Yiddishe Chestushkes (Cherniafsky)—Tenor—
 Orch. Accomp.....Aaron Lebedeff 10
- POPULAR SONGS**
- 14479 In a Corner of the World (All Our Own)
 (Keyes-Crawford)—Tenor—Orch. Accomp.,
 Irving Kaufman 10
 Mother's Love (Loescher-Schmidt)—Tenor—
 Orch. Accomp.....Billy Jones 10
- 14486 Come on Home (Akst-Meyer)—Baritone Orch.
 Accomp.....Ernest Hare 10
 Who Did You Fool After All? (Johnny S.
 Black)—Tenor—Orch. Accomp...Charles Hart 10
- 14487 Away Down East in Maine (Walter Donaldson)
 —Tenor—Orch. Accomp.....Jack Shea 10
 Down by the Old Apple Tree (Wilson-Brennan)
 —Baritone Duet—Orch. Accomp...Scott-Lewis 10
- DANCE SELECTIONS**
- 14472 Fuzzy Wuzzy Bird (Harold Weeks)—Fox-trot,
 Selvin's Orch. 10
 Open Your Arms My Alabamy (Lewis-Young-
 Meyer)—Fox-trot.....Selvin's Orch. 10
- 14473 One Night in June (Snyder-Lange-Klapholz)—
 Fox-trot.....Gene Fosdick's Hoosiers 10

- Lost (A Wonderful Girl) (James Hanley)—
 —Fox-trot.....Gene Fosdick's Hoosiers 10
- 14474 When Hearts Are Young (From "The Lady in
 Ermine")—(Romberg-Goodman)—Fox-trot,
 The Bar Harbor Society Orch. 10
 Journey's End (Intro: "Tie Up," From "Up
 She Goes") (Tierney-McCarthy)—Fox-trot,
 The Bar Harbor Society Orch. 10
- 14476 Runnin' Wild (Grey-Gibbs)—Fox-trot,
 The Southland Six 10
 Ivy (Cling to Me) (Jones-Johnson-Rogers)—
 Fox-trot.....The Southland Six 10
- 14477 I'm Through (Shedding Tears Over You)
 (Norman-Weber)—Fox-trot,
 Selvin's Boardwalk Orch. 10
 Who Cares? (Ager-Yellen)—Fox-trot,
 Selvin's Boardwalk Orch. 10
- 14466 La tristeza de Pierrot (The Sorrow of Pierrot)
 (Beisariode Jesus Garcia)—Fox-trot,
 Max Dolin's Orch. 10
 Pensando en ti (Someone Is Thinking of You)
 (Hegbom-Milburn)—Vals (Waltz),
 Max Dolin's Orch. 10
- 14475 Without You (Moret-Black-Hickman)—Fox-trot,
 The Broadway Syncopaters 10
 Burning Sands (D. Onivas)—Fox-trot,
 The Broadway Syncopaters 10
- 14478 Dumbell (Zez Confrey)—Fox-trot,
 Emil Coleman and His Montmartre Orch. 10
 Lady of the Evening (Irving Berlin) (From
 "The Music Box Revue")—Fox-trot,
 Emil Coleman and His Montmartre Orch. 10
- 14480 Selection From Aida (Arranged by Adrian
 Schubert)—Aeolian Symphony Dance 10
 Yerkes' Metropolitan Dance Players 10
 Selections From Faust (Arranged by Adrian
 Schubert)—Aeolian Symphony Dance,
 Yerkes' Metropolitan Dance Players 10

BRUNSWICK RECORDS

- 50018 Samson et Dalila—Mon coeur s'ouvre a ta
 voix (My Heart at Thy Sweet Voice) (Act
 II) (Saint Saëns)—Contralto, in French,
 Sigrid Onegin 12
 Carmen—Chanson Bohème (Les tringles de
 sistres) (Gypsy Song) (Act II) (Bizet)—
 Contralto, in French.....Sigrid Onegin 12
- 50021 Agnus Dei (Lamb of God) (Bizet)—Tenor Solo
 in Latin—Organ by Frank La Forge, Violin
 Obligato by Fredric Fradkin, Mario Chamlee
 Ave Maria (Kahn)—Tenor Solo in Latin—Piano
 by Frank La Forge, Violin Obligato by Fred-
 ric Fradkin.....Mario Chamlee 12
- 15036 (a) Spinning Song (Mendelssohn); (b) Mo-
 ment Musical (Schubert)—Pianoforte Solo,
 Elly Ney 10
 Ecossaises (Scottish Dances) (Beethoven-
 d'Albert)—Pianoforte Solo.....Elly Ney 10
- 15028 Voi ed Io (You and I) (De Curtis)—Baritone,
 in Italian—Violin Obligato by Fredric Frad-
 kin.....Giuseppe Danise 10
 Luntanaza (Murolo-De Curtis)—Baritone, in
 Italian.....Giuseppe Danise 10
- 50022 Kol Nidrei (Bruch)—Violin Solo—Pianoforte by
 Paul Frenkel.....Bronislaw Huberman 12
 Mazourka (Zarazycke)—Violin Solo—Pianoforte
 by Paul Frenkel.....Bronislaw Huberman 12
- 2351 To a Wild Rose (MacDowell)—Celesta Solo,
 Paul Frenkel 10
 To a Water-Lily (MacDowell)—Celesta Solo,
 Paul Frenkel 10
- 2361 Mississippi Choo Choo (Frost-Rose)—Singing
 Comedienne.....Marion Harris 10
 Who Cares? (Yellen-Ager)—Singing Comedienne,
 Marion Harris 10
- 2357 Rocky Mountain Moon (Egan-Whiting-Marshall)
 Tenor and Baritone,
 Charles Hart-Elliott Shaw 10
 Down by the Old Apple Tree (Wilson-Brennan)
 —Tenor and Baritone, Billy Jones-Ernest Hare 10
- 13058 Heaven at the End of the Road (Johnstone-
 Osgood)—Tenor Solo.....Theo Karle 10
 Little Bit of Heaven (Brennan-Ball)—Tenor
 Solo.....Theo Karle 10
- 5176 I Dreamt I Dwelt in Marble Halls (From "Bo-
 hemian Girl") (Balfe)—Soprano Solo,
 Irene Williams 10
 Moon Song (From "The Mikado") (Gilbert-
 Sullivan)—Soprano Solo.....Irene Williams 10
- 2364 Lost (A Wonderful Girl) (Davis-Hanley)—
 Baritone Solo.....Ernest Hare 10
 Nellie Kelly, I Love You (From "Little Nellie
 Kelly") (George M. Cohan)—Tenor Solo,
 William Reese-White Way Male Quartet 10
- 2359 To-morrow (Turk-Robinson)—Singing Come-
 dienne.....Margaret Young 10
 Jimbo Jambo (Vincent-Frisch-Heuston)—Singing
 Comedienne.....Margaret Young 10
- 2363 The Lonely Nest (Intro: "Then Comes the
 Dawning," From "Orange Blossoms") (De
 Sylva-Victor Herbert)—Fox-trot—Orchestral
 Arrangement by Walter Haenschen,
 Carl Fenton's Orch. 10
- Babylon (Williams-Moret)—Fox-trot,
 Arnold Johnson and His Orch. 10
- 2365 Greenwich Witch (Zez Confrey)—Fox-trot,
 Isham Jones' Orch. 10
 Ivy (Rogers-Johnson-Jones)—Fox-trot,
 Isham Jones' Orch. 10
- 2350 You Gave Me Your Heart (Wheeler-Smith-Sny-
 der)—Fox-trot.....Isham Jones' Orch. 10
 The Sneak (Brown)—Fox-trot,
 Isham Jones' Orch. 10
- 2358 Burning Sands (Meskill-Onivas)—Fox-trot,
 Isham Jones' Orch. 10
 Aunt Hagar's Children Blues (Brynm-Handy)
 —Fox-trot.....Isham Jones' Orch. 10
- 2352 I Still Can Dream (Intro: "My Bajadere" and
 "In the Starlight," From "The Yankee Prin-
 cess") (De Salva-Kalman)—Fox-trot,
 Joseph C. Smith and His Orch. 10
- When Hearts Are Young (Intro: "Dear Land
 o' Mine," From "The Lady in Ermine")
 (Romberg-Goodman-Wood)—Fox-trot,
 Joseph C. Smith and His Orch. 10
- 2362 Swanee Smiles (Hager-Ring)—Fox-trot,
 Oriole Terrace Orch. 10
 Where the Bamboo Babies Grow (Brown-Don-
 aldson)—Fox-trot...Bennie Krueger's Orch. 10
- 2354 Dumbell (Zez Confrey)—Fox-trot,
 Bennie Krueger's Orch. 10
 The Thief (Fisher)—Fox-trot,
 Bennie Krueger's Orch. 10

A WONDERFUL SONG ~ DON'T WONDER ABOUT IT ~ GET IT

I WONDER WHERE MY OLD GAL IS TONIGHT

Published by

SKIDMORE MUSIC CO. Inc.



I won-der where my old gal is to night Oh! dear-ie me

Selling Agents-**SHAPIRO, BERNSTEIN & CO., Inc.** Cor. Broadway & 47th St. New York

ADVANCE RECORD BULLETINS FOR FEBRUARY—(Continued from page 154)

- 2360 Come on Home (Young-Lewis-Akst-Meyer)—Vocal Trio—Vocal Arrangement by Arthur Johnson, Brox Sisters With Bennie Krueger's Orch. 10
- Bring on the Pepper, From "Music Box Revue of 1922-23" (Irving Berlin)—Vocal Trio—Vocal Arrangement by Arthur Johnson, Brox Sisters With Bennie Krueger's Orch. 10
- 2356 Rose of the Rio Grande (Warren-Gorman)—Fox-trot Oriole Terrace Orch. 10
- All Muddled Up (Weinrich)—Fox-trot, Oriole Terrace Orch. 10
- 2355 China Boy (Winfree-Butelje)—Fox-trot, Arnold Johnson and His Orch. 10
- One Night in June (Smith-Wheeler-Klapholz-Lange-Snyder)—Fox-trot, Arnold Johnson and His Orch. 10
- 2353 Lady of the Evening (From "Music Box Revue of 1922-23") (Irving Berlin)—Fox-trot—Orch. Arrangement by Walter Haenschen, Carl Fenton's Orch. 10
- Pack Up Your Sins and Go to the Devil (From "Music Box Revue of 1922-23") (Irving Berlin)—Fox-trot—Orch. Arrangement by Walter Haenschen Carl Fenton's Orch. 10
- 2343 The Fuzzy-Wuzzy Bird (Weeks)—Fox-trot, Isham Jones' Orch. 10
- Broken-Hearted Melody (Jones)—Waltz, Isham Jones' Orch. 10

EDISON BLUE AMBEROL RECORDS

- 4666 Call Me Back, Pal o' Mine, Elizabeth Spencer-Charles Hart
- 4667 Concert Fantasia—Piano Solo Huston Ray
- 4668 A Country Fiddler at the Telephone, Charles Ross Taggart
- 4669 Eleanor—Fox-trot Imperial Marimba Band
- 4670 The Song of Songs Leola Lucey
- 4671 Chung Lo (A Chinese Monkeydoodle)—Banjo Solo Joe Roberts
- 4672 Look Down, Dear Eyes Lewis James
- 4673 Hesitation Waltz (Valse Boston), Ernest L. Stevens' Trio
- 4674 Nailed to the Cross.. Mr. and Mrs. George E. Nhare
- 4675 Only to See Her Face Again, Venetian Instrumental Quartet
- BLUE AMBEROL HITS FOR FEBRUARY, 1923
- 4691 Bee's Knees—Fox-trot Atlantic Dance Orchestra
- 4692 The Cat and the Canary—Fox-trot, Kaplan's Melodists
- 4693 Delaware Elizabeth Spencer-Charles Hart
- 4694 Cock-A-Doodle-Do—Fox-trot, Harry Raderman's Orch.
- 4695 You Gave Me Your Heart (So I Give You Mine)—Fox-trot Broadway Dance Orch.

EDISON DISC RE-CREATIONS

- SPECIALS
- 51086—Artist's Reverie—Hesitation Waltz—Piano Solo, Ernest L. Stevens
- Valse—Intermezzo From "The Love Cure"—Piano Solo Ernest L. Stevens
- 51052 Somewhere in Dixie—Banjo Solo.. Shirley Spaulding
- A Footlight Favorite—Banjo Solo.. Shirley Spaulding
- 51051 While the Years Roll By, Elizabeth Spencer-Lewis James
- Pal of All Pals Joseph Phillips
- 51023 Sweet Southern Dream (Walter Scanlan) With Elizabeth Spencer in the Refrain "Fancies" Lewis James
- 51096 Lucia Sextet—Transcription—Piano Solo, Ferdinand Himmelreich
- Variations on "Swanee River"—Piano Solo, Ferdinand Himmelreich
- 51099 Why Am I Always Alone? (Vernon Dalhart) (Intro.: Helen Clark in the Refrain, "Will She Come From the East?") (East-North-West or South), (From "Music Box Revue, 1922-23") ... J. Harold Murray and Mixed Chorus
- FLASHES
- 51100 Lady of the Evening (From "Music Box Revue, 1922-23")—Fox-trot Broadway Dance Orch.
- Crinoline Days (From "Music Box Revue, 1922-23")—Fox-trot Broadway Dance Orch.
- 51102 Fate (It Was Fate When I First Met You)—Fox-trot Atlantic Dance Orch.
- Mah Jongg Blues—Fox-trot Atlantic Dance Orch.
- 51105 "Calanthe" Waltzes—Piano Solo.. Ernest L. Stevens
- Far From Thee—Waltzes—Piano Solo, Ernest L. Stevens
- 51104 Dumbell—Fox-trot Broadway Dance Orch.
- Baby Blue Eyes—Fox-trot Stevens' Trio
- GENERAL LIST
- 51097 Love's Paradise (I Never Knew), Elizabeth Spencer-Charles Hart
- In Rose Time Elizabeth Spencer-Charles Hart
- 80757 These Are They—The Holy City Anna Case
- Rejoice Greatly—Messiah Anna Case
- 80758 Verranno a te sull' aure—Lucia di Lammermoor Anna Case-Ralph Errolle
- E il sol dell' anima—Rigoletto,

- 51098 I Still Can Dream (From "The Yankee Princess")—Fox-trot Broadway Dance Orch.
- Ma Bajadere (From "The Yankee Princess")—Fox-trot Broadway Dance Orch.
- 51101 The Old Homestead Walter Scanlan and Chorus
- Star of Faith Walter Scanlan-Helen Clark
- 51107 Annie Laurie—Transcription—Piano Solo, Ferdinand Himmelreich
- Love's Old, Sweet Song—Transcription—Piano Solo Ferdinand Himmelreich
- 51108 One Night in June—Fox-trot, Broadway Dance Orch.
- When Hearts are Young (From "The Lady in Ermine")—Fox-trot Broadway Dance Orch.
- 51109 Just Before the Battle, Mother, Jim Doherty and Chorus
- When I Dream of That Mother of Mine, Walter Van Brunt and Chorus
- 51110 Faded Love Letters (of Mine) (Intro.: "The Homestead Trio") J. Harold Murray
- I'll Take You Home Again, Pal o' Mine (Intro.: "Helen Clark") Walter Scanlan

OKEH RECORDS

- 4710 Childhood Days (Henry Creamer-Dave Franklin)—Fox-trot Blue Ribbon Trio
- Who Loves You Most, After All? (Henry R. Cohen)—Fox-trot Blue Ribbon Trio
- 4711 I Certainly Must Be in Love (William Tracey-Dan Dougherty)—Contralto With Orch., Elsie Clark
- For Crying Out Loud (Ben Ryan-Mort Dixon-Violinsky)—Contralto With Orch., Elsie Clark
- 4712 Zenda (From the Photo Play, "Prisoner of Zenda") (Louis Breau-Ernst Luz)—Soprano—Accomp. by Piano and Chimes. ... Eva Clark
- Zenda (From the Photo Play, "Prisoner of Zenda") (Louis Breau-Ernst Luz)—Fox-trot, Rega Dance Orch. 10
- 4713 Vamp Me (And I'll Vamp You) (Byron Gay)—Fox-trot Rega Dance Orch.
- Carolina in the Morning (From the Winter Garden "Passing Show of 1922") (Walter Donaldson)—Fox-trot Natzy's Biltmore Orch. (Jack Green, Director)
- 4714 Cock-A-Doodle-Do (Cliff Friend-Con Conrad)—Fox-trot Rega Dance Orch.
- When Those Finale Hoppers Start Hopping Around (Harry White-Willie White)—Fox-trot Okeh Syncopators (Harry Reser, Director)
- 4715 I'll Build a Stairway to Paradise (From George White's "Scandals of 1922") (George Gershwin)—Fox-trot Markels' Orch.
- Two Little Ruby Rings (From the Musical Comedy, "Daffy Dill") (Herbert Stothart)—Fox-trot Markels' Orch.
- 4716 My Buddy (Walter Donaldson)—Waltz, Markels' Orch. 10
- Mellow Moon (Wendell W. Hall)—Fox-trot, Rega Dance Orch. 10
- 4717 To-morrow Morning (M. Parish-E. Young-H. D. Squires)—Fox-trot Rega Dance Orch.
- Pharaoh Land (H. D. Squires-B. Haring)—Fox-trot The Original Six (Geo. Kelly, Director)
- 4718 Suez (Ferdie Grofe-Peter De Rose)—Oriental Fox-trot Markels' Orch.
- Gee! But I Hate to Go Home Alone (James F. Hanley)—Fox-trot.... Natzy's Biltmore Orch. (Jack Green, Director)
- 4719 A Kiss in the Dark (From the Musical Play, "Orange Blossoms") (Victor Herbert)—Waltz, Markels' Orch. 10
- Thru the Night (Frederic Knight Logan)—Waltz, Markels' Orch. 10
- 4720 Lovely Lucerne (Felix Godin)—Saxophone-Accordion Duet Gaylord-Gaylord
- Love Sends a Little Gift of Roses (John Openshaw)—Saxophone-Accordion Duet, Gaylord-Gaylord
- 4721 Aloha Oe (Farewell to Thee) (Queen Liliuokalani)—Tenor Solo, Accomp. by Kalani Peterson's Trio Prince Lei Lani
- Hawaii Pono (Hawaiian National Anthem)—Tenor Solo, Accomp. by Kalani Peterson's Trio Prince Lei Lani
- 4722 Arkansasaw Traveler Reel (Intro.: "Arkansasaw Traveler," "Fischer's Hornpipe," "Chicken Reel," "Mississippi Sawyer Reel")—Violin Solo Joseph Samuels
- Miss McCloud's Medley Reel (Intro.: "Miss McCloud's Reel," "Kelton Reel," "Devil's Dream," "Fairy Dance," "Ireland's Reel")—Violin Solo Joseph Samuels
- 4723 My Old Hawaiian Home (Ray Sherwood-F. W. Vandersloot)—Mixed Trio, Accomp. by Special Orch. Crescent Mixed Trio
- Dream Kiss (Alfred J. Rienzo)—Standard Hawaiian Instrumental—Imitation Hawaiian Guitar by Virginia Burt, Frank Ferera-Anthony Franchini 10

- 4724 In the Gloaming (Orred-Harrison)—Male Quartet Shannon Four 10
- Juanita (Norton)—Male Quartet. Shannon Four 10
- 4725 He Loves It (Grant Clarke-Edgar Leslie-Pete Wendling)—Contralto With Orch. Elsie Clark
- Kiss Mama, Kiss Papa (Al. Herman-Geo. Fairman)—Contralto With Orch. Elsie Clark
- 4726 Hello! Hello! Hello! (Young-Lewis-Harry Akst)—Tenor-Baritone Duet With Orch., Billy Jones-Ernest Hare 10
- Toot, Toot, Tootsie (Goo' Bye) (G. Kahn-E. Erdman-D. Russo)—Tenor-Baritone Duet With Orch. Billy Jones-Ernest Hare 10
- 4727 United Order of Possum Catchers Lodge (Miller-Lyles)—Dialogue Miller-Lyles 10
- Can't Do It (Miller-Lyles)—Dialogue, Miller-Lyles 10
- 4728 You Gave Me Your Heart (H. B. Smith-F. Wheeler-T. Snyder)—Tenor With Orch., Lewis James 10
- I'll Be in My Dixie Home Again To-morrow (Roy Turk-J. Russell Robinson)—Male Trio With Orch. Crescent Trio 10
- 4729 Where the Bamboo Babies Grow (From George White's "Scandals of 1922") (Walter Donaldson)—Fox-trot..... Rega Dance Orch. 10
- Choo-Choo Blues (Elmer Barr)—Fox-trot, Okeh Syncopators 10
- (Harry Reser, Director)
- 4730 Mary, Dear (Some Day We Will Meet Again) (Harry De Costa-M. K. Jerome)—Tenor With Orch. Lewis James 10
- You Remind Me of My Mother (From the Musical Comedy, "Little Nellie Kelly") (George M. Cohan)—Tenor Solo, Piano Accomp. by Justin Ring Charles Hart 10
- 4731 Jokes (Ring-Hager)—Okeh Laughing Dance Record—Laughing Fox-trot... Rega Dance Orch. 10
- Jokes (Ring-Hager)—Okeh Laughing Dance Record—Laughing Fox-trot... Rega Dance Orch. 10
- 4732 Lovin' Sam (The Sheik of Alabam') (Milton Ager)—Fox-trot Guyon's Paradise Orch. (Jules R. Herbiveaux, Director) 10
- Silver Swanee (Eddie Cantor-Jean Schwartz)—Fox-trot Guyon's Paradise Orch. (Jules R. Herbiveaux, Director) 10
- 4733 Bee's Knees (Ted Lewis-Ray Lopez)—Fox-trot, Rega Dance Orch. 10
- All Muddled Up (Percy Wenrich)—Fox-trot, Okeh Syncopators 10
- (Harry Reser, Director)
- 3034 My Bajadere (From the Operetta, "Yankee Princess") (E. Kalman)—Orchestra, Marek Weber and His Orch. 12
- (Recorded in Europe)
- Massary-Trot (J. Gilbert)—Orchestra, Marek Weber and His Orch. 12
- (Recorded in Europe)
- 3035 Batik, Valse Boston (L. Ramms)—Orchestra, Dajos Bela and His Orch. 12
- (Recorded in Europe)
- Papillon, Valse Boston (Butterfly)—Orchestra, Dajos Bela and His Orch. 12
- (Recorded in Europe)
- 5011 Slavonic Dance No. 8 (Dvorak)—Symphony Orch. Eduard Morike and the Orch. of the German Opera House, Berlin 12
- (Recorded in Europe)
- Slavonic Dance No. 6 (Dvorak)—Symphony Orch. Eduard Morike and the Orch. of the German Opera House, Berlin 12
- (Recorded in Europe)
- 5012 Tales of Hoffmann—Barcarolle (Barcarolle aus Hoffmann's Erzählungen) (J. Offenbach)—Sung in German—Orch. Accomp., Emmy Heckmann-Bettendorf, Soprano Margarethe Jaeger-Weigert, Mezzo-Soprano (Recorded in Europe)
- Tales of Hoffmann—Antonia's Romance ("Sie entflohe die taube," aus Hoffmann's Erzählungen) (J. Offenbach)—Sung in German—Orch. Accomp., Emmy Heckmann-Bettendorf, Soprano (Recorded in Europe)
- 53104 Waltz in A Flat (Chopin)—Piano Solo, Eugene D'Albert 12
- (Recorded in Europe)
- 53201 I Pagliacci—Vesti La Giubba (On With the Play) (Leoncavallo)—Tenor With Orch.—Sung in Italian Nino Piccaluga 12
- 63001 Tosca—E. Lucevan Le Stelle (The Stars Were Shining) (Puccini)—Tenor With Orch.—Sung in Italian Nino Piccaluga 10
- 72602 Forza Del Destino—La Vergine Degli Angeli (May Angels Guard Thee) (Verdi)—Sung in Italian, Giannina Russ, Soprano, With La Scala Opera Chorus, Milan 10 3/4

GENNETT LATERAL RECORDS

- 4999 The Rosary—Steel Guitar Solo. Bessie Keaunui With Bell's Famous Hawaiians (Continued on page 156)

ADVANCE RECORD BULLETINS FOR FEBRUARY—(Continued from page 155)

- Honolulu March—Steel Guitars, Bessie Keaunui, Accomp. by H. Lishman With Bell's Famous Hawaiians
- S5000 Barcelona (Wheeler)—Fox-trot, Nathan Glantz y su orquesta
- Fox-trot De Las Campanas (Pastalle), Nathau Glantz y su orquesta
- 5001 To-morrow Morning (Young-Squires)—Fox-trot, Bailey's Lucky Seven
- Gee! But I Hate to Go Home Alone (Hanley)—Fox-trot, Bailey's Lucky Seven
- 5002 Lady of the Evening (Berlin)—Fox-trot, Glantz's Metropolitan Players
- Carolina Home (Davis-Silver)—Fox-trot, Bailey's Lucky Seven
- 5003 Irish Polka—Bagpipes and Violin, Tom Ennis-John Carridy
- Piano Accomp., Paddy Muldoon
- Medley of Irish Reels—Bagpipes and Violin, Tom Ennis-John Carridy
- Piano Accomp., Paddy Muldoon
- 5004 Bee's Knees (Lopez-Lewis)—Fox-trot, Bailey's Lucky Seven
- Where the Bamboo Babies Grow (Walter-Donaldson)—Fox-trot, Bailey's Lucky Seven
- 5005 Lost (A Wonderful Girl) (Davis-Hanley)—Fox-trot, Bailey's Lucky Seven
- I Gave You Up Just Before You Threw Me Down) (Kalmar-Ruby-Ahlert)—Fox-trot, Glantz's Metropolitan Players
- 5006 Barcelona (Wheeler)—Fox-trot, Nathan Glantz and His Orch.
- Fox-trot of the Bells (Pastalle), Nathan Glantz and His Orch.
- 5007 Don't Bring Me Posies (It's Shoesies That I Need) (McCabe-Jennings-Rose)—Soprano, Aileen Stanley
- You Tell Her—I Stutter (Rose-Friend)—Baritone and Tenor, Ernest Hare-Billy Jones
- 5008 U A Like No A Like (My Heart's Desire) (Everett)—Tenor, Prince Lei Lani
- Accomp. Hawaiian Quartet
- Sweet Lei Lehua (The Scarlet Scented Flower) (King Kalakaua)—Tenor, Prince Lei Lani
- Accomp. Hawaiian Quartet
- 5009 San (McPhail-Michaels)—Fox-trot, Husk O'Hare's Super Orchestra of Chicago
- Eccentric (Robinson)—Fox-trot, Friar's Society Orch.
- Direction of Husk O'Hare
- 5010 Schultz Dictates a Letter—Monologue, Frank Kennedy
- Schultz Has His Life Insured—Monologue, Frank Kennedy
- 5011 Pack Up Your Sins and Go to the Devil (Berlin)—Fox-trot, Cal Smith's American Orch.
- Who Did You Fool, After All? (Van-Schenck-Black)—Fox-trot, Cal Smith's American Orch.
- 2520 Liebeswaltzer—Waltz, Schwabische Bauern Kapelle
- Schwabische—Polka, Schwabische Bauern Kapelle
- 4916 The Sinner and the Song (Thompson)—Orch. Accomp., Rodeheaver and Criterion Quartet
- The Church in the Wildwood—Unaccomp., Rodeheaver and Criterion Quartet
- 4917 A Story of Love (Gabriel)—Baritone, Homer Rodeheaver
- When the World Forgets (Ackley)—Baritone, Homer Rodeheaver

EMERSON PHONOGRAPH CO.

LATEST DANCE HITS

- 10567 Early in the Morning, Blues—Fox-trot, Lada's Louisiana Orch.
- Alabi Blues—Fox-trot, Lada's Louisiana Orch.
- 10568 Lovelight in Your Eyes—Fox-trot, Lanin's Roseland Dance Orch.
- When the Leaves Come Tumbling Down—Fox-trot, Emerson Dance Orch.
- Vocal Chorus—Irving Kaufman
- 10569 Fate—Fox-trot, Emerson Dance Orch.
- Down in Maryland—Fox-trot, Lanin's Roseland Dance Orch.
- 10570 Jimbo Jambo—Fox-trot, Lada's Louisiana Orch.
- When Will I Know?—Fox-trot, Lada's Louisiana Orch.
- 10573 Make the Trombone Laugh—Novelty Fox-trot, Bal Tabaren Orch.
- Saxophobia—One-step, Rudy Wiedoeft
- POPULAR SONG HITS
- 10571 Honey Moon Time—Tenor and Baritone Duet, Orch. Acc., Irving and Jack Kaufman
- Baby Blue Eyes—Baritone Solo, Orch. Acc., Arthur Fields
- 10572 Way Down East in Maine—Tenor Solo, Orch. Acc., Irving Kaufman
- Way Down Yonder in New Orleans—Baritone Solo, Orch. Acc., Arthur Fields
- 10574 Long Gone, Blues—Novelty, Noble Sissle
- Baltimore Buzz, Blues—Novelty, Noble Sissle
- CLASSIC
- 10575 Largo—Violin Solo, Piano Acc., Maximilian Rose
- Minuet in G—Violin Solo, Piano Acc., Maximilian Rose

BANNER RECORDS

DANCE RECORDS

- 1139 Open Your Arms, My Alabama—Fox-trot, Roy Collins' Orch.
- What a Fool I've Been—Fox-trot, Imperial Dance Orch.
- 1140 'Way Down Yonder in New Orleans—Fox-trot, Sam Lanin's Roseland Dance Orch.
- Baby Blue Eyes—Fox-trot, Six Black Diamonds
- 1141 Crinoline Days (From "Music Box Revue")—Fox-trot, Roy Collins' Orch.
- Journey's End (Intro.: "Tie Up," From "Up She Goes")—Fox-trot, Louis Katzman's Dance Orch.
- 1142 Mellow Moon—Waltz, Jos. Knecht's Dance Orch.
- Red Moon—Waltz, Jos. Knecht's Dance Orch.
- 1143 Running Wild—Fox-trot, Original Memphis Five
- Loose Feet—Fox-trot, Original Memphis Five
- 1144 Away Down East in Maine—Fox-trot, Jos. Samuels and His Orch.
- Sunny Jim—Fox-trot, Six Black Diamonds
- 1145 The Thief—Fox-trot, Hollywood Dance Orch.
- Dumbell—Fox-trot, Jos. Samuels and His Orch.
- 1146 When Hearts Are Young (From "Lady in Ermine")—Fox-trot, Hollywood Dance Orch.
- Fuzzy-Wuzzy Bird—Fox-trot, Majestic Dance Orch.
- POPULAR VOCAL RECORDS
- 1147 To-morrow—Baritone Solo—Orch. Accomp., Arthur Fields
- 'Way Down Yonder in New Orleans—Tenor Solo—Orch. Accomp., Vernon Dalhardt
- 1148 Toot, Toot, Tootsie—Baritone Solo—Orch. Accomp., Arthur Fields



SELLING MUSICAL MERCHANDISE

By J. R. FREW

This is a practical book that describes the methods pursued by a successful music dealer in conducting his musical merchandise departments. It covers every routine problem incident to establishing and operating a department devoted to band and orchestra instruments.

This branch of the music industry has had a very prosperous year and an excellent opportunity awaits other dealers who take it up. It requires a small investment, gets quick turnover, involves no risk and, in addition to being highly profitable itself, increases the sale of talking machines, records, etc., and helps make a given store the music center of its community.

READ THE CONTENTS of THIS PRACTICAL BOOK

Chapter From the Publisher. Introduction.

PART I THE PROBLEM OF BUYING

- I. Buying in General.
- II. Importance of Quality in Buying.
- III. Where to Buy.
- IV. Future Buying.
- V. Buying for Special Sales.
- VI. Some Don'ts for the Buyer.

PART II THE PROBLEM OF PUBLICITY

- VII. Advertising in General.
- VIII. Space or Display Advertising.
- IX. Advertising by Personal Contact.
- X. Advertising Through Service.
- XI. Direct and Mail Advertising.
- XII. Advertising Through Musical Attractions.

PART III THE PROBLEM OF MANAGEMENT

- XIII. Management in General.
- XIV. Stock Display.
- XV. The Care of Stock.
- XVI. Inventory and Sales Analysis.
- XVII. The Question of Credit.
- XVIII. The Repair Department.
- XIX. The Value of Co-operation.

PART IV THE PROBLEM OF SELLING

- XX. Selling in General.
- XXI. The Sales Organization.
- XXII. Psychology of Salesmanship.
- XXIII. Collective Selling.
- XXIV. Organizing a Band or Orchestra.
- XXV. The Used Instrument Problem.

PART V INSTRUMENTATION

- XXVI. Musical Organizations and their Instrumentation.
- XXVII. The Principal Instruments of the Band and Orchestra Described.

APPENDIX List of Principal Musical Merchandise Products

FREE INSPECTION OFFER

Edward Lyman Bill, Inc.
373 Fourth Avenue, New York.

You may send me, on five days' free inspection, your book SELLING MUSICAL MERCHANDISE. I agree to return it to you within five days, or remit \$2.00

Name

Address City

- When the Leaves Come Tumbling Down—Tenor Solo—Orch. Accomp., Billy Clarke
- 1149 Coal-Black Mammy—Duet—Orch. Accomp., Billy Clarke-Bert Green
- Open Your Arms, My Alabama—Tenor Solo—Orch. Accomp., Vernon Dalhardt
- HAWAIIAN RECORD
- 2067 Three o'Clock in the Morning—Vocal Chorus, Vernon Dalhardt-Hawaiian Guitars
- Ferera-Franchini
- Pua Mohala—Old Hawaiian Melody—Hawaiian Duet, Ferera-Franchini

PATHE FRERES PHONOGRAPH CORP.

ACTUELLE LIST

- STANDARD VOCALS
- 020871 One More Ribber to Cross—Jubilee Song, Jim Europe's Four Harmony Kings
 - Ev'rybody Dat Talks 'Bout Heaven Ain't Goin' There, Jim Europe's Singing Serenaders
 - 020872 Breakfast in My Bed on Sunday Mornin' (Scotch Dialect), Scott Blakeley
 - I Loved Her Ever Since She Was a Baby (Scotch Dialect), Scott Blakeley
 - 020873 Long, Long Ago, Christine Church-Mary Scott
 - Sing Me to Sleep, Christine Church-Mary Scott
 - OPERATIC AND CONCERT ARTISTS
 - 025095 I'll Sing Thee Songs of Araby, Eleanora de Cisneros
 - Juanita, Eleanora de Cisneros
 - 025096 Love Sends a Little Gift of Roses—Violin Solo, Alexander Debruille
 - Mignon "Gavotte"—Violin Solo, Alexander Debruille
 - 025097 Comin' Thro' the Rye, Yvonne Gall
 - Good-Bye!, Yvonne Gall
 - POPULAR VOCAL
 - 020869 Little Pal of Long Ago, Robert Bruce
 - Rocky Mountain Moon, Arthur Wilson-Frank Sterling
 - 020874 I'm Just a Little Blue (For You), Charles Cinway
 - Don't Forget Me When You're Gone, Charles Cinway
 - 020875 I Miss You, Frank Sterling
 - What a Fool I've Been, Arthur Wilson
 - 020876 Carolina in the Morning, Robert Judson
 - Down in Maryland, Robert Judson
 - NEGRO VOCAL
 - 020877 Evil-Minded Blues, Anna Meyers and Original Memphis Five
 - Last Go Round Blues, Anna Meyers and Original Memphis Five
 - 020878 Who'll Drive Your Blues Away? Lavinia Turner and Jas. P. Johnson's Harmony Seven
 - When the Rain Turns Into Snow (Who's Gonna Keep You Warm?), Lavinia Turner and Jas. P. Johnson's Harmony Seven
 - DANCE
 - 020883 Running Wild—Fox-trot, Majestic Dance Orch.
 - Loose Feet—Fox-trot, Majestic Dance Orch.
 - 020884 Journey's End (Intro.: "Tie Up," From "Up She Goes")—Fox-trot, Majestic Dance Orch.
 - When Hearts Are Young (From "Lady in Ermine")—Fox-trot, Max Terr and His Orch.
 - 020885 Crinoline Days (From "Music Box Revue")—Fox-trot, Max Terr and His Orch.
 - Porcelain Maid (From "Music Box Revue")—Fox-trot, Max Terr and His Orch.
 - 020886 Bee's Knees—Fox-trot, Golden Gate Orch.
 - Dumbell—Fox-trot, Don Parker's Western Melody Boys
 - 020887 Save the Last Waltz for Me—Waltz, Max Terr and His Orch.
 - Love's Lament—Waltz, Majestic Dance Orch.
 - 020888 Railroad Man—Fox-trot, Original Memphis Five
 - Great White Way Blues—Fox-trot, Original Memphis Five
 - 020889 Away Down East in Maine—Fox-trot—Vocal Chorus, Robert Judson, Long Beach Society Serenaders
 - Carry Me Back to My Carolina Home—Vocal Chorus, Robert Judson, Long Beach Society Serenaders
 - 020890 Who Cares?—Fox-trot, Golden Gate Orch.
 - The Lonely Nest (From "Orange Blossoms")—Fox-trot, Hazay Natzy's Orch.
 - 020891 Down in Maryland—Fox-trot, Hazay Natzy's Orch.
 - One Night in June—Fox-trot, Don Parker's Western Melody Boys
 - 020892 Flower of Araby—Fox-trot, Long Beach Society Serenaders
 - Silver Swanee—Fox-trot, Golden Gate Orch.

REGAL RECORDS

DANCE RECORDS

- 9407 Running Wild—Fox-trot, Original Memphis Five
- Loose Feet—Fox-trot, Original Memphis Five
- 9408 Crinoline Days (From "Music Box Revue")—Fox-trot, Majestic Dance Orch.
- Baby Blues Eyes—Fox-trot, Jos. Samuels and His Orch.
- 9409 Open Your Arms, My Alabama—Fox-trot, Majestic Dance Orch.
- Sunny Jim—Fox-trot, Jos. Samuels and His Orch.
- 9410 Red Moon—Waltz, Jos. Knecht's Dance Orch.
- Mellow Moon—Waltz, Jos. Knecht's Dance Orch.
- 9411 'Way Down Yonder in New Orleans—Fox-trot, Sam Lanin's Roseland Dance Orch.
- What a Fool I've Been—Fox-trot, Hollywood Dance Orch.
- 9412 When Hearts Are Young (From "Lady in Ermine")—Fox-trot, Imperial Dance Orch.
- Journey's End (Intro.: "Tie Up," From "Up She Goes")—Fox-trot, Louis Katzman's Dance Orch.
- 9413 Away Down East in Maine—Fox-trot, Six Black Diamonds
- Dumbell—Fox-trot, Six Black Diamonds
- 9414 The Thief—Fox-trot, Imperial Dance Orch.
- Fuzzy-Wuzzy Bird—Fox-trot, Hollywood Dance Orch.
- POPULAR VOCAL RECORDS
- 9415 To-morrow—Baritone Solo—Orch. Accomp., Arthur Fields
- 'Way Down Yonder in New Orleans—Tenor Solo—Orch. Accomp., Vernon Dalhardt
- 9416 Coal-Black Mammy—Duet—Orch. Accomp., Billy Clarke-Bert Green
- When the Leaves Come Tumbling Down—Tenor Solo—Orch. Accomp., Billy Clarke
- 9417 Toot, Toot, Tootsie—Baritone Solo—Orch. Accomp., Arthur Fields
- Open Your Arms, My Alabama—Tenor Solo—Orch. Accomp., Vernon Dalhardt
- HAWAIIAN RECORD
- 9418 Three o'Clock in the Morning—Vocal Chorus, Vernon Dalhardt-Hawaiian Guitars
- Ferera-Franchini
- Pua Mohala—Old Hawaiian Melody—Hawaiian Duet, Ferera-Franchini

Some Leading Jobbers of Talking Machines in America

TEST IT. 

OUR VICTOR

Record Service

has a reputation for efficiency.
Suppose you try it.

E. F. DROOP & SONS CO.
1300 G. STREET, WASHINGTON, D. C.
231 N. HOWARD STREET, BALTIMORE, MD

W. J. DYER & BRO.
DYER B'LD'G, ST. PAUL, MINN.
NORTHWESTERN DISTRIBUTORS
OF THE

VICTOR

Machines, Records and Supplies



Shipped Promptly to all
Points in the Northwest

Mickel Bros. Co.

Omaha, Nebraska
Des Moines, Iowa

Victor Distributors



Where Dealers May Secure

COLUMBIA

Product

Sherman, Clay & Co.

San Francisco, Los Angeles, Portland, Seattle, Spokane

PACIFIC COAST DISTRIBUTORS OF
VICTOR PRODUCTS

The

Toledo Talking Machine Co.

Toledo, Ohio

**Wholesale Victor
Exclusively**

SOUTHERN
VICTOR WHOLESALERS

The Corley Company

RICHMOND VIRGINIA

Ready, Full Stocks, and Prompt Deliveries
from Convenient Shipping Centers
all over the United States

Distributors

- Atlanta, Ga., Columbia Graphophone Co., 561-563 Whitehall St.
 - Baltimore, Md., Columbia Graphophone Co., 16 South Howard St.
 - Boston, Columbia Graphophone Co., 1000 Washington St.
 - Buffalo, N. Y., Columbia Graphophone Co., 737 Main St.
 - Chicago, Ill., Columbia Graphophone Co., 325 W. Jackson Blvd.
 - Cincinnati, O., Columbia Graphophone Co., 317-321 East 8th St.
 - Cleveland, O., Columbia Graphophone Co., 1812 East 30th St.
 - Dallas, Tex., Columbia Graphophone Co., 316 North Preston St.
 - Denver, Colo., Columbia Stores Co., 1608 Glenarm Ave.
 - Detroit, Mich., Columbia Graphophone Co., 115 State St.
 - Kansas City, Mo., Columbia Graphophone Co., 2006 Wyandotte St.
 - Los Angeles, Cal., Columbia Graphophone Co., 809 S. Los Angeles St.
 - Minneapolis, Minn., Columbia Graphophone Co., 18 N. 3rd St.
 - New Orleans, La., Columbia Graphophone Co., 323 North Peters St.
 - New York City, Columbia Graphophone Co., 121 West 20th St.
 - Omaha, Neb., Columbia Graphophone Co., Eighth and Jackson Sts.
 - Philadelphia, Pa., Columbia Graphophone Co., 40 N. 6th St.
 - Pittsburgh, Columbia Graphophone Co., 632-640 Duquesne Way.
 - Salt Lake City, Utah, Columbia Stores Co., 221 South West Temple.
 - San Francisco, Cal., Columbia Graphophone Co., 345 Bryant St.
 - Seattle, Wash., Columbia Graphophone Co., 911 Western Ave.
 - Spokane, Wash., Columbia Stores Co., 161 South Post St.
 - St. Louis, Mo., Columbia Graphophone Co., 1127 Pine St.
 - Tampa, Fla., Tampa Hardware Co.
- Headquarters for Canada:
Toronto, Ont., Columbia Graphophone Co., 347 West Adelaide St.
Montreal, Que., Columbia Graphophone Co., 824 St. Denis St.

Executive Office

COLUMBIA GRAPHOPHONE CO.
Gotham National Bank Building New York

CONSTRUCTIVE ARTICLES IN THIS ISSUE OF THE WORLD

Ready Reference for Salesmen, Dealers and Department Heads

| | | | |
|--|----|---|---------|
| Belief in Product Essential to the Salesman | 3 | Successfully Overcoming the Post-Holiday Business Decline..... | 26 |
| The Talking Machine as an Educational Medium Offers Wide Field for Business Development..... | 4 | Good Prospects for 1923 Shown in Extended Survey of the Talking Machine Trade | 29-40 |
| Close of the Old Year Leaves Clear Field for New Year of Progress and Development | 6 | Some Sales Stimulators..... | 43 |
| Trade Is Entering the New Year With Confidence | 8 | The Value of the Artistic Window.. | 44 |
| Progress Toward Musical Appreciation | 8 | The Status of Radio in the Talking Machine Store | 53 |
| How Best to Overcome the Inclination to Relax | 8 | The Actual Sales Possibilities of Effective Settings for Period Instruments | 58 |
| The Vital Importance of Collections | 8 | Clever Plan Boosts Sales of Records | 59 |
| The Popularity of Flat Top Models of Talking Machines..... | 9 | Featuring the Musical Possibilities of the Talking Machine..... | 72-73 |
| Retaining the Patronage of Old Customers Is an Important Element in Business Progress | 10 | Review of Trade Conditions in Boston and New England..... | 83-86 |
| Necessity for Keeping the Talking Machine Owner's Interest Alive.. | 12 | Trade Happenings in the Quaker City and Pennsylvania | 95-97 |
| Analysis of Conditions Existing in the Various Stores Which Help and Retard Growth | 14 | New Conceptions of Business Practices Are Assuming Growing Importance | 98-99 |
| Four-minute Conference on Business Topics | 15 | Mid-West Point of View and General Western Trade News..... | 102-114 |
| Some Timely Hints on Advertising.. | 18 | Important New Posts for Two Victor Co. Officials | 122 |
| Our Exports of Talking Machines... | 19 | Interesting Budget of News From the Dominion of Canada..... | 124 |
| How Co-operative Advertising Brings Patronage to a Group of Live Dealers | 22 | Gleanings From the World of Music | 131-138 |
| Getting Into a Rut Sounds the Death Knell of Business Prosperity and Progressiveness | 24 | The Talking Machine Situation in Europe | 150-151 |
| | | Late Patents of Interest to the Talking Machine Trade | 152-153 |
| | | Advance List of February Bulletins of Talking Machine Records.... | 154-156 |

A · C · B · Z · A · C · O · F · H · I · K · L · N · P · O · S · U · A · X · V · B · D · F · G · J · Y · L · N · P · O · S · U · V · X · Z · V · C · E · F · H · J · K · W · O · P · R · T · A · C · E · M · O · N · P · O · R · T · Y · H · S · V · W · Y · K · W · Y · A · T · S · R · Q · O · M · K · J · H · F · E · C · V · B · C · E · F · H · I · K · W · O · D · R · T · U · V · W · Y · Z · S · D · E · G · I · J · M · J · O · Q · S · T · V · M · Y · V · B · D · M · B · C

INDEX TO ADVERTISERS

A

Aeolian Co. 32, 33
 Alto Mfg. Co. 108
 American Mica Works 142
 Andrews, Curtis N. 29

B

Bagshaw Co., W. H. 46
 Barnhart Bros. & Spindler..... Inside back cover
 Bell Recording Co. 66
 Berlin, Inc., Irving..... 136, 137, 138
 Blackman Talking Machine Co..... 71
 Blood Tone Arm Co..... 114
 Boston Book Co. 18
 Brand, William 142
 Brilliantone Steel Needle Co..... 47
 Bruno & Son, Inc., C. 77
 Bruns & Sons, A. 6
 Brunswick-Balke-Collender Co. Insert following page
 Buegeleisen & Jacobson 142
 Buehn Co., Louis 95
 Buffalo T. M. Co. 90

C

Cabinet & Accessories Co..... 81
 Cheney Talking Machine Co..... 13
 Chicago T. M. Co. 101
 Claravox Co. 70
 Claremont Waste Mfg. Co. 86
 Classified Want Ads. 149
 Columbia Graphophone Co.... 16, 17, 27, 35, 48, 50, 55, 59, 70, 73, 88, 92, 120, 128
 Columbia Mantel Co. 119
 Consolidated Talking Machine Co..... 52, 110
 Corley Co. 157
 Crosley Mfg. Co. 69

D

Diamond Products Co. 72
 Diaphragm Co. 73
 Ditson & Co., Chas. H. 83
 Ditson Co., Oliver 83
 Doctorow, D. R. 146
 Dodin, Andrew H. 153
 Doerr-Andrews-Doerr 21
 Droop & Sons Co., E. F. 157
 Duo-Tone Co. 61
 Dyer & Co., W. J. 157

E

Eastern Talking Machine Co..... 85
 Eclipse Musical Co. 76
 Edison, Inc., Thos. A. 38, 39, Back Cover
 Eight Famous Victor Artists..... 27
 Emerson Phono. Co. 80
 Empire Mfg. Co. 24
 Empire Phono. Parts Co..... 67
 Eshborn, Samuel 49
 Everybody's T. M. Co. Insert following page
 Excel Phono. Mfg. Co. 112

F

Favorite Mfg. Co. 41
 Feist, Leo.... 26, 34, 42, 51, 56, 64, 68, 76, 84, 86, 94, 108, 111, 119, 132, 140, 146, 148
 Fletcher-Wickes Co. 89
 Fox Pub. Co., Sam. 135
 Fox-Vliet Drug Co. 21
 Fulton T. M. Co. 146b

G

General Phonograph Corp. Inserts following pages 18, 50 and 66
 General Phonograph Mfg. Co..... 42
 General Radio Corp. 129
 Gibson-Snow Co. 21
 Globe Distributing Corp. 143
 Granby Phono. Corp. 45
 Greater City Phono. Co. 14, 21
 Gretsch Mfg. Co., Fred..... 58

H

Hall Mfg. Co. 100
 Harper & Bros. 123
 Harponola Co. 43

Health Builders 23
 Heater, L. D. 40
 Hessig-Ellis Drug Co. 21
 Hough, J. E., Ltd. 150
 Hyman & Co., Inc., Henry..... 31

I

Ilsley, Doubleday & Co. 115
 Independent Recording Labs. 59
 International Mica Co. 97, 125
 Iroquois Sales Co. 48
 Italian Book Co. 22

J

Jenkins' Sons Co., J. W. 131
 Jewel Phonoparts Co. 62, 63, 99
 Jewett Radio & Phono. Co. 127

K

Kent Co., F. C. 51
 Kiefer-Stewart Co. 21
 Kimball Co., W. W. 111
 Kirkman Engg. Co. 117
 Knickerbocker T. M. Co. 30
 Knight, Fred W. 94
 Kraft, Bates & Spencer, Inc..... 84
 Krasco Mfg. Co. 112

L

Lakeside Supply Co. 110
 Lauter Co., H. 56
 Lee-Coit-Andresen Hdw. Co. 21
 Lidseen Products 122
 Long Cabinet Co., Geo. A. 60, 75
 Long Island Phono. Co. 21, 118
 Lyradion Mfg. Co. 79

M

Magnavox Co. 21
 Magnola T. M. Co. 104
 Manhattan Recording Laboratories..... 87
 Manufacturers' Phono. Co. 65
 Marks Music Co., Edw. B. 139, 144
 Marvel Record Co. 145
 McMenimen, H. N. 55
 Mellor Co., C. C. 51
 Mermod & Co. 68
 Metal Recording Disc Co. 141
 Modernola Co. 36
 Mohawk Works of Art 87
 Moore-Bird & Co. 21
 Music Publishers Protective Assn. 130
 Musical Instrument Spec. Co. 139
 Mutual Phono. Parts Co. 12

N

National Co. 87
 National Decalcomania Co. 97
 National Metals Depositing Corp..... 66
 National Publishing Co. 18
 Netschert, Frank 59
 New England Talking Machine Co. 85
 New York Album & Card Co. 4
 New York T. M. Co. 101
 Nye & Co., Wm. F. 30

O

Ogden Sectional Cabinet Co., Inc. 54
 Ormes, Inc. 15
 Oro-Tone Co. 103, 106
 Orsenigo Co. 146a
 Outing T. M. Co. 125

P

Pathé Frères Phono. & Radio Corp..... 25
 Peabody & Co., Henry W. 82
 Pearsall Co., Silas E. 9
 Peckham Mfg. Co. 34
 Peerless Album Co. 11
 Penn Phonograph Co. 97
 Penn Phonograph Co. of New York..... 140
 Phillips Phono. Parts Co., Wm. 78
 Phonomotor Co. 55, 88, 139
 Plaza Music Co. 44

Pleasing Sound Phono. Co. 86
 Plywood Corp. 26
 Polk Furn. Co., J. K. 116

R

Rapid Repeater Co. 120
 Regal Record Co. 91
 Remick & Co., Jerome H. 74, 134, 137, 138
 Rene Manufacturing Co. 124
 Rex Gramophone Co. 151
 Robichek, Rudolph 91

S

Seaburg Mfg. Co. 19
 Shapiro Bernstein Co. 155
 Shelton Elec. Co. 147
 Sherburne Mfg. Co. 50
 Sherman, Clay & Co. 10
 Silent Motor Corp. 53
 Smith Drug Co., C. D. 21
 Sonora Co. of Philadelphia 21
 Sonora Distributing Co. of Pittsburgh..... 21
 Sonora Phono. Co. of New England 21
 Sonora Phonograph Co., Inc. Inside front cover, 20, 21, 79
 Sonora Phono. Co. of Illinois 21
 Sonora Sales Co. of New Jersey..... 21
 Southern Drug Co. 21
 Southern Sonora Co. 21
 Sphinx Gramophone Motors 98
 Standard Accessory Corp. 64
 Star Mach. & Nov. Co. 122
 Steger & Sons Piano Mfg. Co. 93
 Strevell-Paterson Hardware Co. 21
 Sturgis Novelty Wks. 29
 Stylus Bar & Mfg. Co. 57
 Superior Flake Graphite Co. 68
 Swanson Portable Phono. Distr. 128

T

Talking Machine Co., Phila. 96
 Talking Machine Supply Co. 149
 Talking Machine World Trade Directory
 Insert following page 98
 Toledo Talking Machine Co. 157
 Tonofone Co. 110

U

Unique Reproduction Co. 37
 Unit Construction Co. 121
 United Mfg. & Distr. Co. 113
 United Music Stores 96
 United Projector & Film Corp. 57
 Universal Fixture Corp. 126
 Unyversal Utylyty Unyts Co. 108

V

Val's Accessory House 26
 Van Veen & Co. 116
 Varnol Co. 92
 Vicsonia Mfg. Co. 49
 Victor Talking Machine Co. Front cover, 5, 7
 Vitanola T. M. Co. 105

W

Walbert Mfg. Co. 109
 Wallace Institute 107
 Wall Kane Needle Mfg. Co. 35
 Walthall Music Co. 21
 Ward Co., C. E. 49
 Wasmuth-Goodrich Co. 115
 Waterson, Berlin & Snyder 133, 134, 136
 Wax & Novelty Co. 64
 Weymann & Son, H. A. 96
 Whitsit Co., Perry B. 92
 Widdicomb Furniture Co. 146c
 Williams Co., G. T. 118
 Wimpfheimer & Bro., A. 34
 Witmark & Sons, M. 135

Y

Yahr & Lange Drug Co. 21

Z

Zimmerman-Bitter Constr. Co. 122

The NEW Scotford Tonearm and Superior Reproducer



A new external shape of grace and beauty—without changing the internal design:



That same angle turn with the solid inclined plane deflecting the sound waves straight downward into amplifying chamber. That same famous Scotford tone—the tone of refinement—genuinely musical. Now in a tonearm of accepted, conventional, popular design. **WRITE FOR SAMPLES.**

NEW CONSTRUCTION



The long straight tube is of drawn Yellow Brass. Tonearm Base, Main Elbow and Connection Elbow and the Reproducer Frame, Face Ring and Back Plate are cast of TENSO White Brass Alloy—an alloy more than double the tensile strength of cast iron—much stronger, harder and lighter in weight than ordinary white metal alloys. New dies have been produced for casting all parts. The new parts are solidly cast, and are very substantial and durable.



STYLE NO. 1 FINISH
A combination of Nickel or Gold Plate and Black Rubber Japan

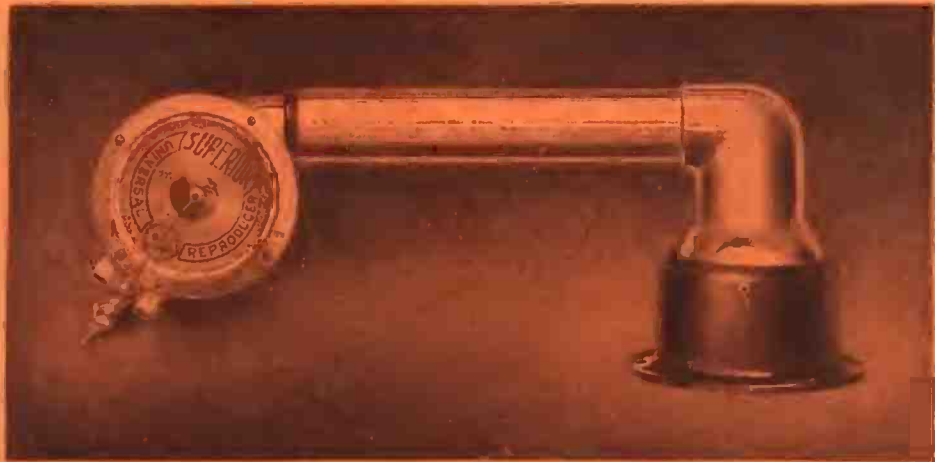

STYLE NO. 2 FINISH
A different combination of Nickel or Gold Plate and Black Rubber Japan



STYLE NO. 3 FINISH
All parts Plated in Nickel or Gold

In ordering specify whether Reproducer should have Plain Gilt Plate or "Superior" Name Plate. To obtain Individual Name Plate, customer must furnish Decalcomania Transfer

Samples Will be Submitted on Approval

| | | |
|---|---|--------------|
| Style 1 Tonearm long tube and main elbow, Reproducer face ring and back Black Japanned; other parts Plated. | Style 2 Tonearm long tube and main elbow Plated, base Black Japanned; Reproducer back Black Japanned, the face ring and frame Plated. | |
| Style 3 All parts of Tonearm and Reproducer are Plated. | | |
| No. 1 New Scotford Tonearm and Superior Reproducer | Nickel \$7.00 | Gold \$ 9.00 |
| No. 2 New Scotford Tonearm and Superior Reproducer | Nickel 7.75 | Gold 10.00 |
| No. 3 New Scotford Tonearm and Superior Reproducer | Nickel 8.50 | Gold 11.00 |
| <i>Samples Prepaid at the Above Prices</i> | | |

Write for Our
Specification Sheet and Quantity Price List

BARNHART BROTHERS & SPINDLER

Monroe and Throop Streets

CHICAGO, ILLINOIS

Four Console Models That Make Easy Sales

THE latest New Edison
consoles offer perfect
musical quality and beautiful
design, in a range of prices
to suit every income.



See Pages 38 and 39

**JOBBERs OF THE NEW EDISON, EDISON RE-CREATION, THE NEW EDISON DIAMOND AMBEROLA
AND BLUE AMBEROL RECORDS**

CALIFORNIA
Los Angeles—Edison Phonographs,
Ltd.
San Francisco—Edison Phonographs,
Ltd.

COLORADO
Denver—Denver Dry Goods Co.

GEORGIA
Atlanta—Phonographs, Inc.

ILLINOIS
Chicago—The Phonograph Co.
Wm. H. Lyons (Amberola only).

INDIANA
Indianapolis—Phonograph Corpora-
tion of Indiana.

IOWA
Des Moines—Harger & Blish.

LOUISIANA
New Orleans—Diamond Music Co.,
Inc.

MASSACHUSETTS
Boston—Pardee-Ellenberger Co.
Iver Johnson Sporting Goods Co.
(Amberola only).

MICHIGAN
Detroit—Phonograph Co. of Detroit.

MINNESOTA
Minneapolis—Laurence H. Lucker.

MISSOURI
Kansas City—The Phonograph Co.
of Kansas City.
St. Louis—Silverstone Music Co.

MONTANA
Helena—Montana Phonograph Co.

NEBRASKA
Omaha—Shultz Bros.

NEW JERSEY
Orange—The Phonograph Corp. of
Manhattan.

NEW YORK
Albany—American Phonograph Co.
Syracuse—Frank E. Bolway & Son,
Inc., W. D. Andrews Co.
(Amberola only).

OHIO
Cincinnati—The Phonograph Co.
Cleveland—The Phonograph Co.

OREGON
Portland—Edison Phonographs, Ltd.

PENNSYLVANIA
Philadelphia—Girard Phonograph
Co.
Pittsburgh—Buehn Phonograph Co.
Williamsport—W. A. Myers.

RHODE ISLAND
Providence—J. A. Foster Co.
(Amberola only).

TEXAS
Dallas—Texas-Oklahoma Phono-
graph Co.

UTAH
Ogden—Proudfit Sporting Goods Co.

VIRGINIA
Richmond—The C. B. Haynes Co.,
Inc.

WISCONSIN
Milwaukee—The Phonograph Co. of
Milwaukee.

CANADA
Montreal—R. S. Williams & Sons
Co., Ltd.
St. John—W. H. Thorne & Co., Ltd.
Toronto—R. S. Williams & Sons
Co., Ltd.
Vancouver—Kent Piano Co., Ltd.
Winnipeg—R. S. Williams & Sons
Co., Ltd.
Babson Bros. (Amberola only).