

*The* **TALKING**  
**MACHINE**  
**WORLD**

*For the  
 makers &  
 sellers of  
 talking  
 machines*

Published Each Month by Edward Lyman Bill, Inc., at 373 Fourth Ave., New York, July 15, 1922

# Victrola

REG. U.S. PAT. OFF.

The word "Victrola" as well as the picture "His Master's Voice" is an exclusive trademark of the Victor Talking Machine Company. Being registered trademarks they cannot lawfully be applied to other than Victor products.



**"HIS MASTER'S VOICE"**

REG. U.S. PAT. OFF.

**Victor Talking Machine Company, Camden, N.J.**

America's Leading Establishments  
Sell and Endorse as a High Quality  
Phonograph



*The Highest Class Talking Machine in the World*

Among the several thousand merchants selling Sonoras, many conduct the largest or leading establishment in their respective cities.

The latest establishments of national reputation to add the Sonora line are James McCreery & Co. and Abraham & Straus. And even now other great companies are negotiating for a much-desired Sonora representation. These famous firms are not opening new departments. Many of them have been selling only one line for years and are taking on the Sonora in addition because of the insistent demand for it.

The fact that these powerful stores sell the Sonora is a hint to you that you cannot afford to ignore. Notice the partial list of great Sonora agencies below, think it over, and write for our proposition.

NEW YORK

John Wanamaker  
James McCreery & Co.  
Bloomingdale's  
Hearn's  
Frederick Loeser & Co.  
Abraham & Straus

PHILADELPHIA

N. Snellenburg & Co.  
Lit Brothers  
John Wanamaker

BOSTON

Jordan Marsh Company

CHICAGO

Rothschild & Company

DETROIT

J. L. Hudson Company

DENVER

Daniels & Fisher

LOS ANGELES

Barker Brothers

SAN FRANCISCO

City of Parish Dry Goods Co.

SEATTLE

Fraser-Paterson Co.

KANSAS CITY

The Jones Store Company

ST. LOUIS

Stix, Baer & Fuller

**Sonora Phonograph Company, Inc.**

GEO. E. BRIGHTSON, *President*

NEW YORK : 279 BROADWAY

Canadian Distributors: I. Montagnes & Co., Toronto



# The Talking Machine World

Vol. 18. No. 7

New York, July 15, 1922

Price Twenty-five Cents

## MARCONI INVENTS NEW DEVICE

Inventor of Wireless Exhibits Mechanism for Directing Radio Sound Waves Before Engineers

With a "baby wireless set" sending signals across about twenty feet of space, Senator Guglielmo Marconi at a lecture before 1,000 engineers in New York City recently demonstrated how a flying shaft of radio waves may be hurled in a desired direction, straight at a receiving station intended to receive it. It illustrated one of his most recent experiments—one on which he and his staff of engineers are still working.

He used the same midget apparatus to point out a vast undeveloped field of the radio—the field of the short wave, which, Senator Marconi thinks, is capable of as high development and use as the long-distance field employing waves of thousands of meters in length for hurling messages across oceans and continents.

Marconi received a welcome due the "master of the wireless" when he appeared in the auditorium of the Engineering Societies Building to deliver a lecture on recent developments in the radio and to receive the Medal of Honor of the American Institute of Radio Engineers for his discoveries in 1921.

In the shooting of the wave a reflector apparatus is used and the wave is caught at the receiving end on a horizontal metal standard. When the semi-circular reflector, a skeletonized apparatus covered with wires and resembling a dish cut in half, is turned with its open side toward the receiving stations the signals are strong and clear. When the open part of the apparatus is turned away the signals become inaudible.

With this system applied to telephony sounds are recorded in much clearer notes and reception is possible on the transmitting aerial while the transmitter is operating.

Telling of his experiments with the short waves recently Senator Marconi said that the greatest trouble to the experimenters had been caused by gas engines, because every ignition plant in a motor, in engine or boat is a potential wireless set, sending out waves from one to forty meters in length. These waves, especially in America, create an immense static condition all its own.

"If radio has already done so much for the safety of life at sea," he said, "for commerce and for commercial and military communications, it is also destined to bring new and, until recently, unforeseen opportunities for healthy recreation and instruction into the lives of millions of human beings."

## APPROVE REORGANIZATION PLAN

Creditors of Pathé Frères Phonograph Co. Favor Reorganization Program

The plan of reorganization submitted by the reorganization committee of the Pathé Frères Phonograph Co. seems to be meeting with universal favor among the creditors of the company. The Music Publishers' Protective Association, through the medium of E. C. Mills, chairman of the board of directors, has placed his stamp of approval on the plan in a letter sent to Eugene C. Widmann, formerly president and now one of the receivers in equity of the Pathé Frères Phonograph Co. It was announced that the Association adopted a resolution recommending that the plan be supported and that each creditor member forward his agreement to the committee.

In closing his letter Mr. Mills stated: "Mindful of years of pleasant and profitable relationship with your company, we are anxious to co-operate in any and every consistent manner in assisting toward its rehabilitation. You have our best wishes and if there is anything we can do to serve you in the matter please do not hesitate to command us."

## GRAND RAPIDS HOUSE ADDS CHENEY

Wurzburg Dry Goods Co. Features This Line in "Cheney Week"—Devotes Large Floor Space to Elaborate Display—F. C. Dietzel Is Manager

GRAND RAPIDS, MICH., July 5.—Van Korn-Shower Co., Michigan distributor for the Cheney phonograph, with headquarters in Detroit, is quite proud of the successful opening of a Cheney department by the Wurzburg Dry Goods Co., one of the largest department stores in this city.

Large advertisements in the local newspapers heralded the event and twenty-five feet of window display space, attractively arranged, invited passers-by to visit the elaborate exhibition in the store.

The Wurzburg Co. set aside an entire week and termed it "Cheney Week." About five thousand



Cheney Display at Wurzburg Co.

feet of floor space was devoted to the display of Cheney instruments, embracing every model. In addition to the large floor display the management placed a machine on the main floor facing the entrance to the store, where it could not escape the notice of every person entering the building. On all floors, directly in front of the elevators, machines of the upright type were placed, each one carrying a card on which was the message: "Cheney Week, Phonograph Department Fifth Floor."

The success of the opening is now making itself manifest in the great number of sales that are resulting from the first visits of prospective customers during the inauguration of the line.

F. C. Dietzel, manager of the music section and one of the best-posted phonograph and piano men in the country, states he is extremely gratified with the results he has attained with the Cheney line the short time he has had it. Every visitor to the phonograph department was presented with a package of needles and a song book during the opening week.

The Latona Talking Machine Co., of Evansville, Ind., has increased its capital stock by an issue of \$50,000 of preferred stock.

## ALL SET FOR OUTING OF TALKING MACHINE MEN, INC.

Even the Cripples and the Blind Will Find Entertainment at the Big Picnic on July 26, for There Is Something Scheduled to Please Everybody—Make Your Reservations Now

As The World goes to press all plans are practically completed for the annual outing and games of the Talking Machine Men, Inc., which will be held at Karatsonyi's Hotel, Glen Head, N. Y., on Wednesday, July 26. The committee of arrangements, of which Sol Lazarus is chairman, has arranged a program that should serve to make the occasion most interesting and pleasant for everyone concerned, for there have been events programed calculated to meet every one's desire for pleasure.

The outing party will leave East Fifty-seventh street, New York, between First and Second avenues, at 9 a. m. sharp and proceed to Glen Head, arriving at about 11 o'clock. Luncheon will be the first event, following which there will be a three-inning baseball game for dealers only, and then a baseball game for jobbers exclusively. The track and field events include a seventy-yard

## NEW TALKING PICTURE INTRODUCED

Satisfactory Synchronization of Film and Talking Machine Record Demonstrated in New York—Some Details of the Mechanism

The synchronization of the talking machine record and the motion picture film, which has been attempted by many inventors during the past couple of decades, appears to have been accomplished to a degree at least by a combined mechanism being exploited by the Vocal-Educational Film Corp., with headquarters in New York.

The corporation, which controls a score or more patents known as Rogers and Ebling patents, has been conducting demonstrations of the new talking pictures on Broadway for the purpose of interesting the public in financing the proposition. In the demonstrations the picture and the voice are perfectly synchronized, although the volume and distinctness of the talking machine reproductions leave much to be desired. This problem will probably be solved satisfactorily in the future.

The synchronization is brought about through the use of a special film carrying perforations that serve to make contact with the electrical devices controlling the talking machine, thereby starting or stopping the record as desired. The talking machine and the projecting machine are operated by the same motor, thus insuring uniform speed. Ordinary disc records are used and arrangements are made whereby at the conclusion of the first record the second record can be thrown in operation without the slightest interruption, by changing the records intermittently. It is said to be possible to produce an entire opera, using a score or more of records in the operation.

The reproducer is of the electric type and the sound from the record is carried by wires to various parts of the auditorium and dispensed through the medium of amplifiers. It is possible to so regulate the film and the record that the sound will be heard only at intervals during the showing of the film if desired.

The corporation plans to place the machine in theatres, schools, etc., on a rental basis, but actual operations will not begin for some time in the future. Meanwhile, the inventors seem to have accomplished something real in the art, although there is still room for considerable development so far as the clearness of the voice and music is concerned.

Courage is not recklessness. A good example of pure courage is that of the salesman who grits his teeth after constant rebuffs and determines not to give in to any feeling of discouragement.



# How a Saleswoman Created and Developed Talking Machine Business in Her Territory

[Editor's Note:—The following practical paper, by Miss E. Stephens, of F. F. Herrmann's Store, Staten Island, N. Y., won the first prize in the suggestion contest on "How to Improve Victor Business," at the monthly gathering of Metropolitan Victor retailers, held under the auspices of the Knickerbocker Talking Machine Co., Inc., Victor wholesaler, last month. The varied means displayed by Miss Stephens in creating and developing business should prove of interest to our readers.]

The people of our section are Saturday spenders—men who wear working shirts most of the week and on Sunday dress up. You can spend a lot of time during the week going after them. I sold children's books for three years, rang door bells, and in that way came to know people. I made more money then than I probably ever will again.

During the last month I have made a house-to-house canvass of certain sections. I have charge of our store and have to be there a great deal of the time. But I gave half an hour a day to canvassing, and it has brought me three sales of No. 240 machines and one No. 50. This may not be much, but just now it is worth going after, and it shows the possibilities in this field. I have directly traced the selling of these machines to this campaign. When I call at the house I address the woman by her name and say, "We would like to put you on our mailing list. Do you receive the supplements from any other store?" If she does she is a good record prospect and if she doesn't she is a good machine prospect.

I am also interested in doing work for schools. You can do that sort of thing in every community. I gained access by getting in touch with the principal and explained that it was for the good of the school. I talked to her on nationality in music and asked her to let me try it. After permission was granted I brought some records to entertain the children. I started down South. Then we heard Indians, went to Hawaii and heard Hawaiian music, then Japanese and Chinese music. I showed them how there is a rowing rhythm to Italy's music. The children entered right into the spirit of it. I told them the name of the record, let them repeat it, had them sing it, made them pronounce it. We then went to Ireland and came home, all the children singing "Home, Sweet Home."

During the next two weeks I sold two or three of each particular record in that community.

I have classified three ways of getting business.

First, through children in the schools; second, through the home, and third, in the store. If a fellow comes into the store for a record I am going to try to sell him two instead of one. I try to get into the booth before he gets out. While I am wrapping the package I have the customer listening to another record in the booth. Of course, sometimes they will exchange the record for some other that they have already selected, but sometimes they take the new record, too. Then, again, it may be another thought to bring them into the store.

Before the customer goes out I ask if he is

*Just Read and Learn  
How Miss Stephens,  
Undaunted, Went After  
and Secured Business  
Despite Quiet Times*

in need of needles. This is a small item, but the record isn't good without them. I explain the value of the tungsten needle and what it does for the records. Just last week I let a saleslady go because she couldn't do that one thing right.

We call ten people every day on the telephone. On rainy days we manage to keep the operators busy. I think it is best to have a girl call, as she will always talk more graciously to another woman. The usual form of address is: "I am Miss \_\_\_\_\_, from \_\_\_\_\_ shop. Some one has given us your name for our mailing list (it may not always be true, but it works well). We will be pleased to mail you our supplements if you do not receive these from another store. If you are in our neighborhood and need anything in our merchandise, stop in. Ask for me. I would like to wait on you myself. My name is \_\_\_\_\_.

Have you a machine?"

If she says she hasn't, of course there is a prospect. If she says they have an old machine

tell her that you can put this old machine in first class condition. I have traced fifteen direct sales to our telephone this past month. I find very few people are rude; in fact, most of them thank me for calling up.

Even in a large community this will work out if you take the exchange nearest you. Every time I sell a machine I catalog that customer. I try to find out his tastes. A week after I have sold the machine I make a personal call and ask if I can come during the evening and play some records for the family. I tell them to invite some neighbor, relative or friend. I usually take ten records along with me—a little of everything—and give them an idea of the Victor records. Most record buyers do not know of the large variation you have in the Victor library. I have found that customers will take half, at least, of the records I bring up with me. Very often you meet Cousin George or someone there who has no machine and I try to interest him in something. For next month I have twenty-five in mind that I can call upon through these trips.

I go back and catalog the music they like and if it is, say, John McCormack, I call them as soon as I have a good record of his and say, "I have a record of John McCormack's I think you'll like and I'll lay one aside for you. If you don't like there is no obligation whatsoever." It is well to catalog the likes and dislikes of your customer. Last month I called up twenty people who were piano enthusiasts, told them we had a new Rachmaninoff record, something they had never heard anything like before. Of the twenty we laid aside twenty were sold.

I am a confirmed Victor enthusiast. I like to have a lot to learn. I lie awake nights and think of little things to do to improve our business. The Saturday preceding Mothers' Day I realized we hadn't anything to attract for Mothers' Day. I dressed the window simply with John McCormack's record, "Little Mother o' Mine." I also put a card in the window saying, "I cannot tell you, mother, dear, how in my heart you shine." We sold a box of these records that day. I try to think of unusual things, not what everyone else tries out.

The man whose sole satisfaction in his work is the weekly or monthly stipend can safely quit business. His loss will be a relief to any concerned.

THE TALKING MACHINE'S HELPMATE



## DURABILITY

Nyacco albums are durable not only because of the quality and materials used and the strength of construction, but through the loose-leaf system of pockets giving long and lasting satisfaction.

The loose-leaf system allows a torn or soiled pocket to be immediately replaced by a new one, making the album as good as new.

Through the durability of Nyacco albums, dealers and manufacturers are making many satisfied customers.

NYACCO trade mark guarantees durability.

Quotations and Prices on Request.

# New York Album & Card Co., Inc.

NEW YORK

23-25 Lispenard St.

A. W. CHAMBERLAIN

New England Factory Representative  
174 Tremont St., Boston, Mass.

CHICAGO

415-417 S. Jefferson St.



The Only Loose-Leaf Record Album on the Market



# Victor supremacy is the supremacy of performance

Every worth-while achievement in the talking-machine industry is directly traceable to Victor skill and progressiveness. A consideration of vital importance to every dealer in Victor products.

### Victor Wholesalers

- |  |   |
|--|---|
| <b>Atlanta, Ga.</b> .....Elyea Talking Machine Co.<br>Phillips & Crew Piano Co.                              | <b>Milwaukee, Wis.</b> ....Badger Talking Machine Co.   |
| <b>Baltimore, Md.</b> .....Cohen & Hughes<br>E. F. Droop & Sons Co.<br>H. R. Eisenbrandt Sons, Inc.          | <b>Minneapolis, Minn.</b> ..Beckwith, O'Neill Co.   |
| <b>Birmingham, Ala.</b> ...Talking Machine Co.   | <b>Mobile, Ala.</b> .....Wm. H. Reynolds  |
| <b>Boston, Mass.</b> .....Oliver Ditson Co.<br>The Eastern Talking Machine Co.<br>The M. Steinert & Sons Co. | <b>Newark, N. J.</b> .....Collings & Co.  |
| <b>Brooklyn, N. Y.</b> .....American Talking Mach. Co.<br>G. T. Williams Co., Inc.                           | <b>New Haven, Conn.</b> ...The Horton-Gallo-Creamer Co.   |
| <b>Buffalo, N. Y.</b> .....Curtis N. Andrews<br>Buffalo Talking Machine Co., Inc.                            | <b>New Orleans, La.</b> ....Philip Werlein, Ltd.  |
| <b>Burlington, Vt.</b> .....American Phonograph Co.  | <b>New York, N. Y.</b> ....Blackman Talking Mach. Co.<br>Emanuel Blout.<br>C. Bruno & Son, Inc.<br>Charles H. Ditson & Co.<br>Knickerbocker Talking Machine Co., Inc.<br>Musical Instrument Sales Co.<br>New York Talking Mach. Co.<br>Oimes, Inc.<br>Silas E. Pearsall Co. |
| <b>Butte, Mont.</b> .....Orton Bros.   | <b>Oklahoma City, Okla.</b> .....Oklahoma Talking Machine Co.   |
| <b>Chicago, Ill.</b> .....Lyon & Healy<br>The Rudolph Wurlitzer Co.<br>Chicago Talking Machine Co.           | <b>Omaha, Nebr.</b> .....Russ P. Curtice Co.<br>Mickel Bros. Co.  |
| <b>Cincinnati, O.</b> .....Ohio Talking Machine Co.<br>The Rudolph Wurlitzer Co.                             | <b>Peoria, Ill.</b> .....Putnam-Page Co., Inc.  |
| <b>Cleveland, O.</b> .....Cleveland Talking Machine Co.<br>The Eclipse Musical Co.                           | <b>Philadelphia, Pa.</b> ....Louis Buehn Co., Inc.<br>C. J. Heppe & Son.<br>Penn Phonograph Co., Inc.<br>The Talking Machine Co.<br>H. A. Weymann & Son, Inc.   |
| <b>Columbus, O.</b> .....The Perry B. Whitsit Co.  | <b>Pittsburgh, Pa.</b> ....W. F. Frederick Piano Co.<br>C. C. Mellor Co., Ltd.<br>Standard Talking Mach. Co.  |
| <b>Dallas, Tex.</b> .....Sanger Bros.  | <b>Portland, Me.</b> .....Cressey & Allen, Inc.   |
| <b>Denver, Colo.</b> .....The Knight-Campbell Music Co.  | <b>Portland, Ore.</b> .....Sherman, Clay & Co.  |
| <b>Des Moines, Ia.</b> .....Mickel Bros. Co.   | <b>Richmond, Va.</b> .....The Corley Co., Inc.  |
| <b>Detroit, Mich.</b> .....Grinnell Bros.  | <b>Rochester, N. Y.</b> ....E. J. Chapman Co.   |
| <b>Elmira, N. Y.</b> .....Elmira Arms Co.  | <b>Salt Lake City, U.</b> ...The John Elliott Clark Co.   |
| <b>El Paso, Tex.</b> .....W. G. Walz Co.   | <b>San Francisco, Cal.</b> ..Sherman, Clay & Co.  |
| <b>Honolulu, T. H.</b> ....Bergstrom Music Co., Ltd.   | <b>Seattle, Wash.</b> .....Sherman, Clay & Co.  |
| <b>Houston, Tex.</b> .....The Talking Machine Co. of Texas   | <b>Spokane, Wash.</b> ....Sherman, Clay & Co.   |
| <b>Jacksonville, Fla.</b> ..The French Nestor Co.  | <b>St. Louis, Mo.</b> .....Koerber-Brenner Music Co.  |
| <b>Kansas City, Mo.</b> ...J. W. Jenkins Sons Music Co.<br>The Schmelzer Co.                                 | <b>St. Paul, Minn.</b> ....W. J. Dyer & Bro.  |
| <b>Los Angeles, Cal.</b> ...Sherman, Clay & Co.  | <b>Syracuse, N. Y.</b> ....W. D. Andrews Co.  |
| <b>Memphis, Tenn.</b> ....O. K. Houck Piano Co.  | <b>Toledo, O.</b> .....The Toledo Talking Machine Co.   |
|  | <b>Washington, D. C.</b> ...Cohen & Hughes<br>E. F. Droop & Sons Co.<br>Rogers & Fischer  |



Victrola IV, \$25 Oak



Victrola VIII, \$50 Oak

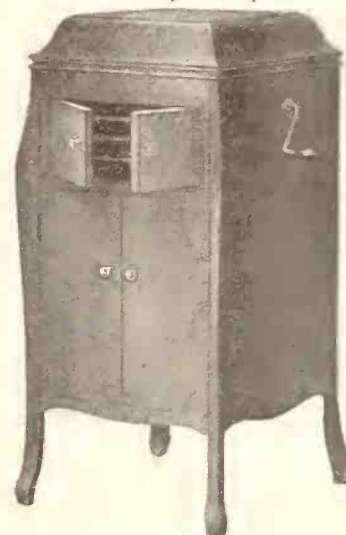

Victrola No. 80 \$100 Mahogany, oak or walnut



Victrola No. 130 \$350  
Victrola No. 130, electric, \$415 Mahogany or oak



"HIS MASTER'S VOICE"

# Victrola

REG. U.S. PAT. OFF.

Important: Look for these trade-marks. Under the lid. On the label.

## Victor Talking Machine Company

Camden, New Jersey



# Records of Religious Numbers and Old-Time Ballads Having a Sales Vogue :: By Arthur H. Foster

Despite the demand for records of popular and dance music of every type many dealers report a very great demand from all classes of people, young and old, for sacred music. This is not surprising, for there are millions of people in the United States who still go to church and who love the old hymns that they learned in the Sunday school in their youth. This applies to every religious persuasion. Despite the modern trend, they like to have the records of these hymns in their home, and it is a question whether this fact is considered by a great many dealers.

In selling records it is always well to keep in mind every phase of merchandising and to appeal to the largest possible clientele of buyers. It must be remembered that the old hymns and the old songs make a very keen appeal to the millions of people who are middle-aged and who have little time to keep in touch with the fugitive jazz numbers, some of which ill deserve the term musical. If every dealer would sit down and consider how many middle-aged people there are in his territory, how many church-goers, and then ask himself how many of these people he has on his books as customers he will be able to get a fair idea whether he is "on the job" or not. It is the time for one to criticise himself—to just ascertain what is being done and what could be done to increase record sales. There is a great deal of empty talking, but not enough action—not enough real constructive performance.

Talking to a dealer along these lines about six weeks ago he admitted that he had not given serious attention to this matter of selling records of religious and old-time music—that is, making a special appeal or drive. The other

day this same dealer told the writer that after a six weeks' carefully developed campaign he had actually sold a surprisingly large number of religious and standard old-time records and, better still, a surprisingly large number of machines to people who heretofore did not seriously consider the value and importance of the talking machine. "Some of these people looked," he remarked, "upon the talking machine, because

*Record Lists Should Be Analyzed Closely and Particular Numbers Picked Out and Featured to Advantage*

of its association with jazz, as something unholy, but when these old church-goers realized that the old standard church hymns could be heard in their parlors on Sundays, as well as the old ballads, it delighted and consoled them, and not only have they become enthusiasts, but they have told their friends about it, with the result that the sales which I have closed from your suggestion have been beyond any calculations which I could possibly make."

Now, we venture to say that there are thou-

sands, yes, millions, of people in America just like those people who have just expressed themselves. And the point is, what are the dealers doing to get this trade? It is to be assumed that a great many dealers are covering this field intelligently and persistently, but there are hundreds, yes, thousands, of others who are doing nothing constructive to push their record business other than along ordinary every-day lines and depending largely upon the public to voluntarily visit the store.

Now, it is time to be up and alive to every opportunity. Dealers should study their lists closely and pick out the various types of records that appeal to the people of varied tastes. They should make special appeals to arouse interest and incidentally move their records more rapidly than they are doing now.

All this implies thought and planning, but that is the duty of every business man. There is no use in having a store and placing goods in it unless the owner can get close to the public and move his product. He can no longer wait for customers to come in; he must seek for trade, and the whole question centers on the modus operandi of seeking and, by seeking, finding customers.

## MONTAUK MFG. CO. CHARTERED

The Montauk Mfg. Co., of Hoboken, N. J., has been granted a charter of incorporation under the laws of the State of New Jersey, for the manufacture of talking machines, with a capital of \$125,000. Incorporators are: William H. Hotchkiss, W. E. Hotchkiss, Henry L. Slade and William S. Stuhr.

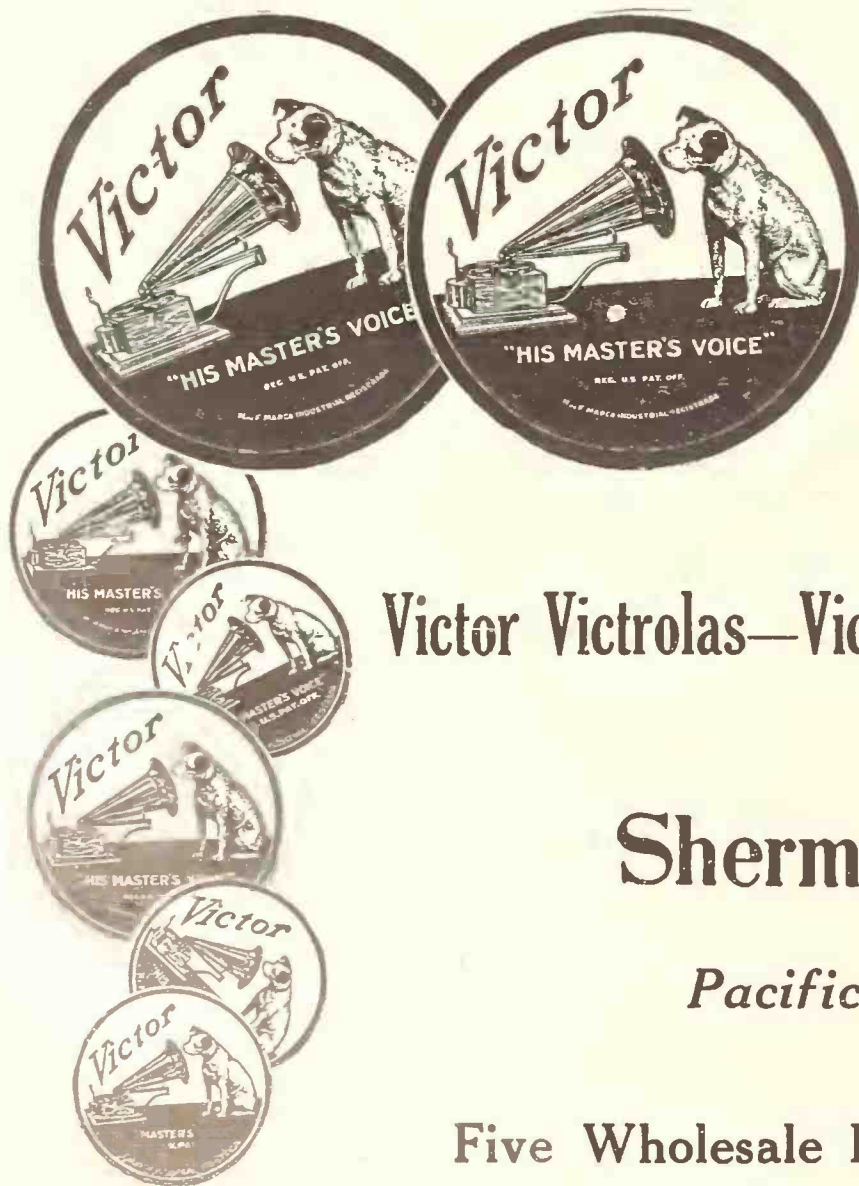

Victor Victrolas—Victor Records—Victor Accessories

Sherman  Clay & Co.

Pacific Coast Distributors

Five Wholesale Depots for Your Convenience

*Main Wholesale Depot:*

741 Mission Street, San Francisco

*Branch Wholesale Depots:*

10th and Santee Sts., Los Angeles, California

N.W. Corner 13th and Glison Streets  
Portland, Oregon

Oceanic Bldg., Cor. University and Post Sts.  
Seattle, Washington

330 W. Sprague Ave., Spokane, Washington



# Victor supremacy is the supremacy of performance



Victrola VI, \$35  
Mahogany or oak



Victrola IX, \$75  
Mahogany or oak

Actual accomplishments are better than promises and expectations. What the Victor has done in the past and continues to do today is the safe index of what the future holds in store for the musical instrument dealer.



Victrola No. 100  
\$150  
Mahogany, oak or walnut

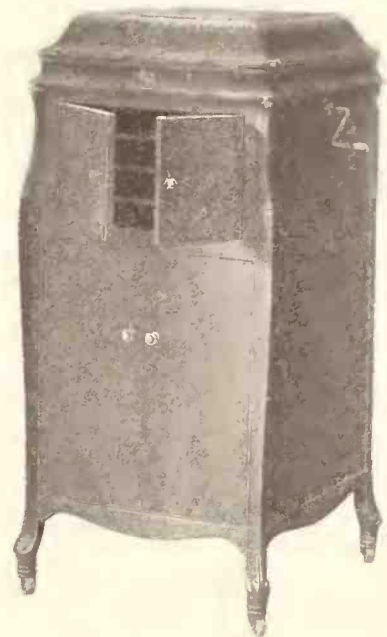

Victrola No. 110  
\$225  
Mahogany, oak or walnut



Victrola No. 300  
\$250  
Victrola No. 300, electric, \$315  
Mahogany, oak or walnut



Victrola No. 330  
\$350  
Victrola No. 330, electric \$415  
Mahogany



"HIS MASTER'S VOICE"

# Victrola

REG. U. S. PAT. OFF.

Important: Look for these trade-marks. Under the lid. On the label.

**Victor Talking Machine Company**  
Camden, New Jersey



# The TALKING MACHINE WORLD

For the makers & sellers of talking machines

(Registered in the U. S. Patent Office)

**PUBLISHED BY EDWARD LYMAN BILL, Inc.**

President and Treasurer, C. L. Bill, 373 Fourth Ave., New York; Vice-President, J. B. Spillane, 373 Fourth Ave., New York; Second Vice-President, Raymond Bill, 373 Fourth Ave., New York; Secretary, E. L. Bill; Assistant Treasurer, Wm. A. Low.

**J. B. SPILLANE, Editor**

**RAY BILL, B. B. WILSON, BRAID WHITE, Associate Editors**

**L. M. ROBINSON, Advertising Manager**

**L. E. BOWERS, Circulation Manager**

Trade Representatives: A. F. CARTER, WILSON D. BUSH, C. CHACE, EDWARD LYMAN BILL, V. D. WALSH, E. B. MUNCH, C. R. TIGHE, SCOTT KINGWILL, A. J. NICKLIN

Western Division: Republic Building, 209 So. State Street, Chicago, Ill. Telephone, Wabash 5242

Boston: JOHN H. WILSON, 324 Washington Street

London, Eng., Office: 2 Gresham Building, Basinghall St. W. LIONEL STURDY, Mgr.

The Talking Machine World has regular correspondents located in all of the principal cities throughout America.

Published the 15th of every month at 373 Fourth Ave., New York.

**SUBSCRIPTION** (including postage): United States, Mexico, \$2.00 per year; Canada, \$3.00; all other countries, \$4.00. Single copies, 25 cents.

**ADVERTISEMENTS:** \$5.50 per inch, single column, per insertion. On quarterly or yearly contracts a special discount is allowed. Advertising pages, \$150.00.

**REMITTANCES** should be made payable to Edward Lyman Bill, Inc., by check or Post Office Money Order.

**NOTICE TO ADVERTISERS**—Advertising copy should reach this office before the first of each month. By following this rule clients will greatly facilitate work at the publication headquarters.

Long Distance Telephones—Numbers 5982-5983 Madison Sq.  
Cable Address: "Elbill," New York

NEW YORK, JULY 15, 1922

## UNUSUAL EFFORTS BRING BUSINESS RESULTS

**S**URPRISING as it may seem to some people, business is being done this Summer by those who are making strenuous efforts to secure it. Dealers who are obsessed with the idea that business is dead and that it is best to drift along until it gets better are, of course, not doing well, and naturally so. Those who are aggressively inclined and who believe that there is always business when properly sought are not complaining. This is briefly the situation in the talking machine trade this Summer.

A prominent member of the trade who has just come back from an extended trip covering important trade centers in the United States, when asked about the situation, thus sententiously summed it up: "Twenty per cent of the merchants who are intelligently active are doing the bulk of the business, while the other 80 per cent, the inactive ones, are complaining, more or less, about the situation."

From reports reaching The World office this remark covers fairly accurately the condition which, in a large measure, prevails throughout the country. Two or three live dealers in a locality report a volume of business equal to or exceeding that of a year ago, and a dozen or more of their competitors, while deprecating poor business, cast doubts on the statements of the prosperous ones.

Now, Mr. Dealer, the question arises in which category are you to be placed? It is in your hands to increase the 20 per cent who are actually doing business, or to augment the 80 per cent who are complaining about conditions. The choice rests with you. It is natural that if there is only a certain volume of business obtainable, and only 20 or 25 per cent of the merchants are really going after it vigorously and getting it, there is logically a mighty small proportion left for those who sit passively doing nothing but complaining and waiting for a change in conditions.

At no time in the history of the trade was it so necessary as to-day to recognize that unusual efforts must be made to develop sales. It is not a time for resting by the wayside; it is a time for pressing onward to victorious accomplishments, and this can only be achieved by the employment of aggressive methods of merchandising—in other words, going after customers rather than waiting for them to call at the store.

While these remarks apply to the sales of talking machines they are even more applicable in the sales of records. There has been a

slump in record sales largely because talking machine dealers and salesmen are not "selling music" to their customers. With many there has been no intelligent follow-up policy adopted; there has been no effort made to secure direct contact, and as a consequence talking machines are not being used as frequently as they should be in the home because the owners have not been educated to the idea that they should buy new records.

Now the progressive minority of dealers, referred to at the opening of this article, who are doing business, have secured the position they occupy by failing to recognize seasons. They have made their customers understand that records are just as entertaining in the Summer as in the Winter months, and as a consequence the output of records has shown a very large proportion of increase with these concerns. What these dealers are doing can be done by every other dealer who is awake to the necessity of aggressive merchandising. There is enough of Summer business to be secured to give every dealer who goes after it a rather satisfying share—if the effort is made.

## PROSPECTS FOR THE FUTURE ARE BRIGHTER

**T**HE message delivered to the members of the National Association of Talking Machine Jobbers at their convention last month by Ralph L. Freeman, Director of Distribution of the Victor Talking Machine Co., is one that is vital not alone to members of the Victor Co. family but to business men in general, who seek to establish their institutions on a permanent basis.

The text of Mr. Freeman's talk was fair dealing, and although every line of the message itself was of great importance the following paragraphs should find a place on the desk of many discerning business leaders:

"The Victor Co.'s message to you is one of good cheer. The shock of the inevitable post-war readjustment has not shaken the solid foundation upon which your business and ours was builded. The prospects for the future are much greater than anything that has been realized.

"New conditions, so large and far-reaching that it is difficult to visualize or comprehend them, are developing throughout the world. They represent greater opportunities for conscientious workers than have heretofore existed, and it is plain that we in this country must benefit from the position of advantage we occupy.

"There is, however, a condition that we must fulfill. We must be faithful—unto others as to ourselves—no less. No mad scramble for business can be allowed to benumb our sense of obligation and fairness else we shall deserve to lose and will lose our opportunity.

"This statement is not a mere platitude, referring generally to the public at large, but a definite fact to be applied to each of us individually who have it in mind to contend within our sphere for a share in the prosperity in the future. We must work and we must be faithful to the trust of those whose patronage we desire."

## VALUE OF INDIVIDUALISM IN ADVERTISING

**C**O-OPERATIVE advertising in one form or another appears to be quite active at present in the music industry as well as in other lines of business, and viewed from the broad angle of increased publicity it is a progressive move. It would appear, however, that some of the plans recently broached are calculated to sacrifice individuality in the carrying out of a general campaign.

It is all well enough for wholesalers or manufacturers to join together and put over campaigns that will be beyond the means of the individual, but the results in proportion to the expenditure are likely to prove distinctly disappointing unless steps are taken to hook up the individual concern with the general campaign and to direct the thought of those appealed to in the general campaign along the proper lines.

In the talking machine trade the manufacturers have carried on for years extensive advertising campaigns—in fact, according to authorities musical instrument advertising in volume comes immediately after the advertising of passenger automobiles, and of this total volume over 90 per cent represents talking machine advertising. The value of this publicity, however, has rested chiefly in the fact that local dealers and distributors have hooked up their own advertising with the general campaigns, that with the desires of the public to purchase a given make duly stimulated, it has taken local advertising to bring the purchaser into the store where the machines or accompanying records could be purchased.



The same idea applies with equal force in the distributing field. It is well enough to flood dealers at regular intervals with stock publicity, but the value of that publicity will lie in the ability of the individual distributor to tie up with the general campaign. He either does that or he is paying a substantial proportion of his competitor's publicity expenses.

Advertising is one field where standardization alone does not make for profits. It is the individual appeal, the ability to persuade the purchaser, whether dealer or ultimate consumer, to do his purchasing from one particular concern—that of the advertiser—that makes the publicity worth while. The manufacturer spends his millions in building up recognition for the name and trade-mark of his product, and it is just as essential that the distributor and dealer devote themselves in some manner at least to building up recognition for their own ends. The firm establishment of a name value in the minds of buyers is the ultimate goal of any sound publicity.

**WINDOW DISPLAYS FOR THE SUMMER BUYER**

**D**URING July and August, the great vacation months of the year, talking machine dealers should make a special effort through window displays to interest vacationists in the portable talking machine and in a goodly number of records to carry along with them on their outings. There is no one factor that contributes more to the enjoyment of a vacation than the talking machine. It entertains with concerts in the evening; supplies dance music where necessary, and is a real friend in need on a rainy day. There is a superabundance of ideas that can be worked by the dealer into striking, suggestive window displays that should arrest the attention of vacationists, and contribute to a goodly increase of sales during the Summer months. It will pay to clear the window out and arrange some kind of a camping scene or install some original conception that will suggest the timeliness of the portable and a goodly supply of records during the vacation period.

**HELPING DEALERS TO ELUCIDATE PROBLEMS**

**T**HE practice of manufacturers, and particularly distributors, either individually or in association with others in the same line, of bringing their dealers together at intervals for the purpose of discussing the problems of the trade as applied to their particular lines and mapping out campaigns that represent co-operative experience is a practice that is worthy of hearty endorsement.

Up to a few years ago the average dealer was, and felt himself, somewhat apart. His only contact with the manufacturer or distributor was through the medium of the salesman who called at regular intervals and the dealer's viewpoint regarding the business as a whole was obtained through salesmen, its accuracy depending upon the latter's ability to collect and then retail the ideas.

The conferences of dealers that have been and are being held at various central points have already accomplished much for them,

and have given to the weaker member the benefits of advice and experience of his successful fellow dealer. Even the successful man has been able to gather one or two ideas that are applicable to his own business.

The big thing, however, is to develop contact between the retailer and the distributor or manufacturer; to give him a new angle on the business; to acquaint him with the general plans for exploiting the product, and to make him feel that he is part of the institution—a partner in its success or failure. There can be no question but that this close contact established between dealers and distributing headquarters through the medium of annual or semi-annual conventions has an intangible value which it is impossible to measure in dollars and cents.

**THE TALKING MACHINE AS AN EDUCATOR**

**D**URING the last two decades the attention of educational authorities throughout the world has been directed to the need for broadening the cultural foundation of the schools, and music has become recognized as affording an unsurpassable basis for general culture. But musical art has in the past been the property almost exclusively of those who possess executive musical talent; that is, of a very few, comparatively speaking. Good listeners, however, are the greatest need, for trained, intelligent listeners alone can constitute the public audience which the musician, creative or executive, must have. Good listeners again are simply those who have been "exposed" to a sufficient quantity of music, who have, in fact, become familiar with it by much hearing and some intelligent guidance. The making of such listeners must naturally begin in the school-room with the rising generation.

Here the talking machine finds its place in the school. By its aid musical culture is taught to thousands who otherwise might never hear an orchestral performance or an orchestral instrument. By its use children are taught to know and love music, to sing and play for themselves, to want more and better music in their daily lives. Within a few years the educational side of the talking machine has assumed outstanding importance and to-day there is hardly a town of any size in the country which does not include at least some talking machine equipment among the items of its educational tool shop, making the talking machine, without a doubt, one of the most potential forces in modern education.

The value of the talking machine in this special field is, in fact, only beginning. The day is at hand when the value of this system of conveying instruction and artistic enjoyment to every corner of the earth will be recognized everywhere as supreme and as no more to be omitted from the school-room than the blackboard or the maps.

Dealers should keep in close touch with the educational authorities in their territories and emphasize strongly at every opportunity the paramount importance of the talking machine as a factor for the advancement of education.



**Ormes**  
**Really**  
**Means**  
**Exceptional**  
**Service**



REG. U.S. PAT. OFF.

This one word distinguishes Ormes service and has contributed not only to our success but to the success of our retailers.

Service that is out of the ordinary—not only in the supplying of merchandise but in helping Victor retailers develop their business.

**ORMES, Inc.**  
*Wholesale Exclusively*

TELEPHONE NUMBERS  
FITZROY 3271—3272—3273

15 West 37th Street

New York



# The Importance of Manners and Their Relation to Effective Sales Work

:: By W. Braid White

Manner is more than merely manners. Yet good manners will make a man even where the more or less frequent distinction of "manner" is lacking. From the salesman's point of view the distinction is important.

The "manner" which distinguishes a man or a woman is the product of his or her birth, environment and education. Men are doubtless created equal in respect of political rights, but they are most decidedly unequal in respect of mental and physical attainments. Now, it is a complaint not infrequently or unjustly made that the men and women of the present generation are ill-mannered; that they have lost the idea of good temper and politeness; that they take an almost savage delight in showing themselves surly and rude. The belief appears to be that politeness is a form of servility and that one cannot show oneself an independent American citizen unless one adopts a tone of superiority or of insolence toward those who are thrown into contact with one in the course of business.

Salesmen ought particularly to consider these facts, for salesmen are particularly susceptible to the error just mentioned. The salesman must wait upon men and women of all kinds and, consequently, his or her success will very largely depend upon manner in general and upon manners in particular.

## Manner vs. "Manners"

There is an enormous difference between manner and mere "manners." Any one can be educated into adopting certain external styles of speech and action, and so any one can be educated into adopting "good manners." But to attain to a natural "manner," to a manner which stamps one as a gentleman or as a lady, is a different sort

of thing altogether and calls for careful study, a fine character and a sincere attitude toward all men and all things.

In the first place, then, be it understood that politeness is not necessarily either familiar or servile. To learn how to smile, to learn how to shake hands, to learn how to give instant and unstudied attention to questions put by a customer, no matter how stupid they may be, all this can and should be learned without leaving

*Manner Is One of the Prime Principles of Salesmanship and an Asset Worthy of Intensive Cultivation*

upon the salesman's nature the slightest trace of servility. In fact, servility is a matter of inner-character. A man who looks down upon those who are less successful materially than himself or who curries favor with those who are higher up in the scale is servile, and though he disguise his servility under ever so many outer mannerisms or tricks of "independent" speech and manner he cannot conceal the essential fact.

The first thing to learn, then, is the lesson of sincerity and kindness. If we really believe that the men and women who pass before us each day in the course of our business and social dealings are really, alike with us, God's children, we shall respect them on the ground of our common humanity and shall therefore treat them as we treat whatever we respect. That is to say, we shall be neither servile nor insolent, but natural, simple and genial.

The prime requisite, in fact, for the attainment of good manners is this sincere belief that men and women are alike entitled to courtesy and attention. It is the mark of ignorance to suppose that insolence or discourtesy are marks of independence. They are simply marks of stupidity and swinishness. The greatest aristocrats are often the most suave, polite and courteous of beings.

## The Brotherhood of Humanity

A salesman has to meet persons of all sorts. No artificial manner will suffice for the proper handling of them all. It is therefore the salesman's duty to learn to believe in his fellow men, to realize that each of them has a right to exist in the world, and to get over the idea that any one is fundamentally better than any one else. Variety is indeed infinite. Men and women are not equal in respect of wealth, opportunity or culture, birth or breeding. But all men and women are nevertheless men and women, enrolled in the brotherhood of humanity and entitled, even when they are themselves bad mannered, to recognition as our fellows.

To recognize this brotherhood in humanity with one's customers is the most important part of that priceless asset, a good manner. For a good manner, as said before, is the natural, unspoiled product of a sincere belief in the fundamental goodness and decency of human beings.

The external accompaniments and signs of the fine manner are, of course, to be found in that natural courtesy that radiates from men and women of fine, broad mentality. Courtesy is expressed in many ways. Courteous men and women do not raise their voices, because they know that a noisy voice usually distresses or disgusts. They do not tell funny stories to casual acquaintances, because they know that many men and women resent such familiarity. They are never effusive, for they realize that excessive politeness too easily degenerates into the manner of the second-hand clothing salesman. They, on the contrary, never refuse a request, are never too busy to stop and listen, never take advantage of the helplessness or ignorance of the aged or of foreigners, and, above all, never laugh at distress or trouble. They are kind to children, but they do not slobber over them. They are polite to all, but they never allow themselves to be known for their extreme politeness. They wait till they are asked to talk and when they talk they say what they mean, without falsehood or rudeness.

The foundations of a fine manner are sincerity and love. Given these, everything else follows. The foundations of good manners are restraint, good temper and consideration for the feelings of others. Both can be acquired. Both are singularly lacking in the equipment of most young men and women who essay to sell. Yet the higher reaches of salesmanship simply cannot be attained without both.

## OHIO FIRM CHARTERED

The Columbia Music Shoppe Co., of Lakewood, O., has been granted a charter of incorporation in that State, with a capital of \$1,000. Incorporators are W. W. Du Breinl, Anna E. Du Breinl, M. L. Stener, D. C. Rolli and E. L. Conson.

## SEND FOR YOUR SAMPLE TO-DAY

This is the New Design



Mr. Victor Retailer—

Would you spend 15c to bring a customer into your store and keep your name constantly before a Victrola owner?

We'll say you will! That is why we will send you a free sample on request of our Advertising Sales-Building Record Brush.

*YOUR ad inserted without extra charge.*

## KNICKERBOCKER TALKING MACHINE CO.

*Victor Wholesalers*

138 West 124th St.

New York City



# Peerless Builds Confidence

## REPUTATION

Reputation is, above all else, the merchant's greatest asset. Fire can burn him out, competitors can harass him with their bargain sales and imitators can steal his thunder, but—if the established reputation remains—his business goes right on.

"\_\_\_\_\_ and Son," or "Established in 18—" are mercantile mile stones which people follow instinctively because of a feeling of certainty in dealing with a store which is founded on reputation and has endured through many years.

A Bazaar is brilliant, noisy and sometimes does a good business, but it passes quickly away and is forgotten, while the names of reputable business institutions are bred into the very conscience of the people.

And a merchant's reputation unquestionably is established on the quality of merchandise he handles.

*Phil Ravis*

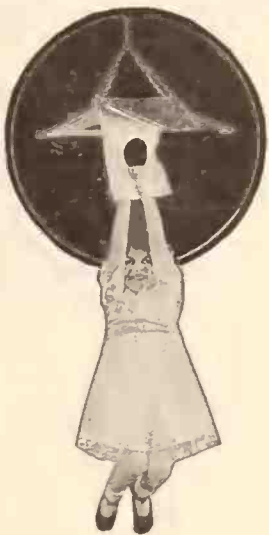

There exists today a new relationship between the retailer and his clientele. It is that of solid confidence and loyalty which merits the approval of all far-seeing merchants and their customers.

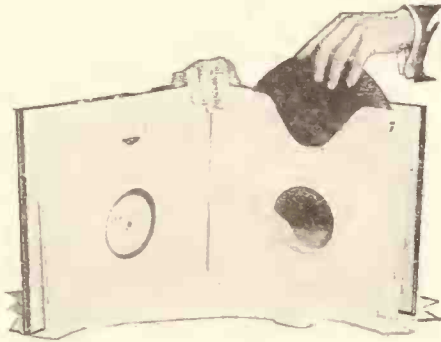

Showing how 10 inch records fit into Peerless Big Ten.

Now is the time to build your business by giving careful attention to the quality and intrinsic value of every article you offer for sale. Give a thought to the most important accessory of the industry and start your "Confidence Campaign" right by selling

## PEERLESS

### —the Album

Have a supply of twelve-inch albums with ten-inch leaves known as Peerless Big Ten; an album which maintains filing uniformity of any phonograph or record cabinet. It is a book which meets the approval of every purchaser of cabinets containing shelves.



Display This Sign—It Will Sell Peerless Albums for You—Send for Yours at Once.

Send for a sample today—and see for yourself that—

## It Does Make A Difference What Albums You Sell

NOTE: Albums, particularly Peerless Albums, do sell records just the same as an empty garage invites an automobile. We said this more than three years ago and have continued saying it; and nothing but the confirmation of the fact has come to us from the trade. What are your ideas on the subject?

# PEERLESS ALBUM COMPANY

PHIL. RAVIS, President

WALTER S. GRAY  
San Francisco  
942 Market St.

636-638 BROADWAY  
NEW YORK

L. W. HOUGH  
Boston  
26 Sudbury St.



# Some Window Display Ideas That Should Help to Increase Record Trade :: By F. H. Williams

Arrange a display of all the records you carry which are designed for the entertainment or amusement or soothing of babies. Then from some local photographers secure photos of babies and place these photos in the window with the records. See to it that the price of each record is clearly indicated. Use a placard with this display emphasizing the fact that a talking machine is a great help in taking care of babies and that you have a particularly big and comprehensive stock of records for the entertainment and amusement of the infants. People are always interested in babies, so this sort of a display would get a lot of attention and help you greatly in selling more records of this sort.

People are always interested in diagrams. This being the case, it would be a good stunt to have a sign painter get up a sign on which would appear a large circle divided into segments representing the amount of business you do in records of various classifications. For instance, one segment could be labeled "Volume of dance records," another could be labeled "Volume of operatic selections," a third might show the amount of business you do in dialogue records, and so on through the various classifications. Above the diagram you could have this inscription painted, "This is a well-rounded store—we do a good business in all lines of records. You can find here the very record you want." In front of the diagram there should be a display of some of the more popular records in all the various classifications. This sort of a stunt would be sure to make a big impression on the folks who looked in at your window.

Everybody knows about the "blues" in music, but who is as familiar with the "reds"? You have

a large number of titles among the records you carry in stock in which the word "red" figures. Why not get some of these records out, place them in your show window, decorate your show window appropriately in red and then place in the foreground of the window a placard reading like this: "You've heard about musical 'blues'—here's where you learn about some of the popular musical 'reds.' Every one of these records has

*The Cheapest and Most Effective Sales Medium for the Talking Machine Dealer Is the Attractive Window*

something red about it and all of them are popular. Come in, get a red record now."

In what shape do you get your shipments of needles? How many different kinds of needles do you regularly carry in stock? It would be interesting to all owners of talking machines to see a window display in which you showed the original packages in which you get your needle shipments and in which you showed the various kinds of needles you carry in stock and in which you told about the special advantages of these

various kinds of needles. Such a window display could be very easily arranged and it would be different from the usual run of phonograph store window displays.

Put a record display stand in the foreground of your show window. Over it place a little placard reading like this: "This is the first record we sold to-day. Come in and get one for your machine." Then on this stand each day place another one of the first records you sell each day. This sort of a stunt would be timely and different and, for that reason, would attract more attention than the ordinary kind of a display and help more than the ordinary display in selling more records.

Paste some of the more popular records on the inside of the glass of your main show window just above the range of vision of the person of average height. Above each record paint the price of the record and some such selling phrase as this: "Snappy dance record," or "Very popular vocal," or something of that sort. All passers-by would be attracted by the unique appearance of your window and in this way you'd get an extra amount of attention for the records and make more than the usual number of sales.

All of these window display ideas can be easily used in your store without much trouble and without much expense. Use them now!

## BUSINESS IS LIKE A TREE

A business can be likened to a tree. The store is the trunk, the salesmen the roots and the customers the leaves. If the roots lack nourishment (knowledge) the trunk withers and there will be no leaves.

# THE EMPIRE UNIVERSAL TONE ARMS

Will Give Your Product Individuality That Will Greatly Strengthen Its Selling Force

Send for sample of our new  
Tone Arm for Portable  
Machines.

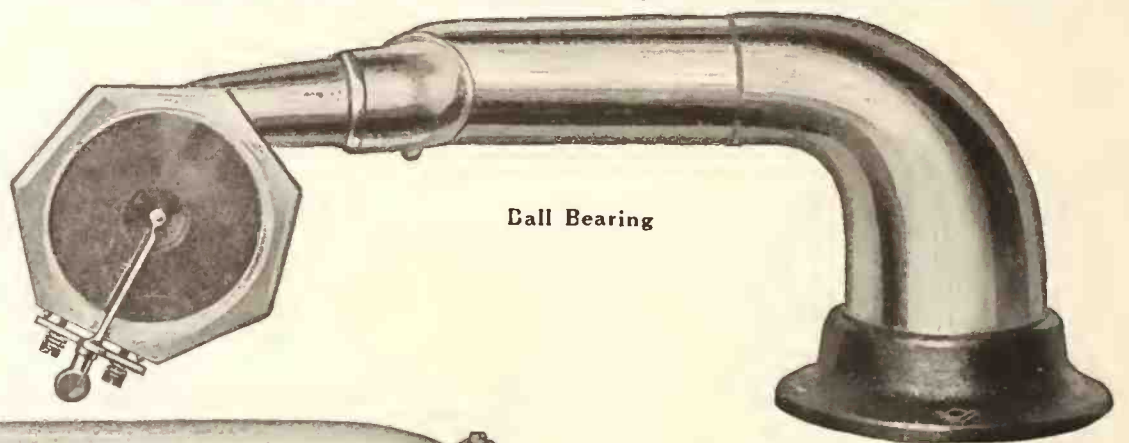

Ball Bearing

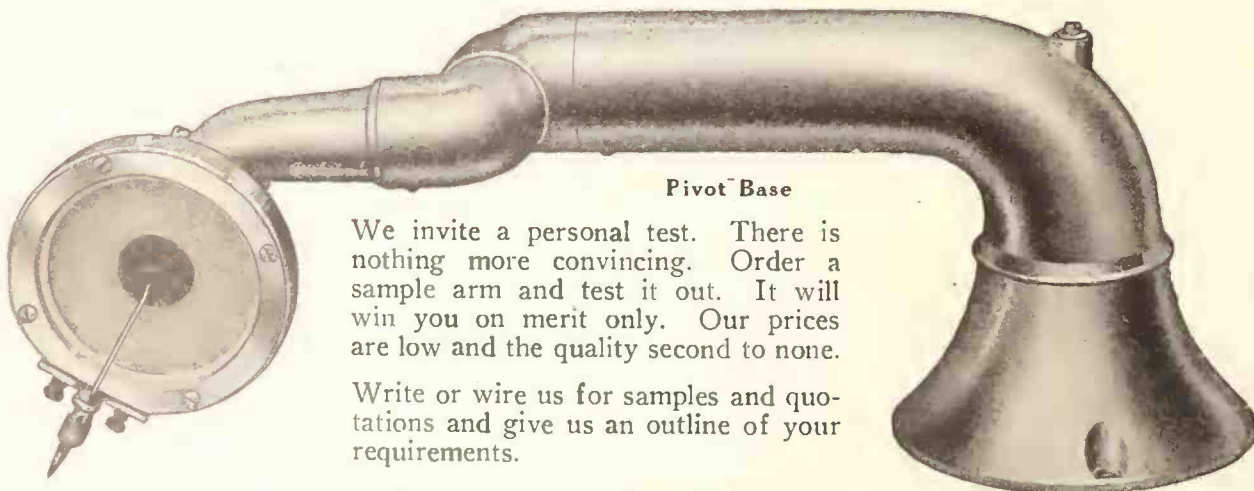

Pivot Base

We invite a personal test. There is nothing more convincing. Order a sample arm and test it out. It will win you on merit only. Our prices are low and the quality second to none.

Write or wire us for samples and quotations and give us an outline of your requirements.

THE EMPIRE PHONO PARTS COMPANY, 1362 East Third Street, Cleveland, O.

Established in 1914

Manufacturers of High-Grade Tone Arms and Reproducers

W. J. McNAMARA, President



# Trend Toward Co-operative Advertising Is Evident Throughout the Country :: By W. B. Stoddard

The old adage that "in union there is strength" finds its modern counterpart in co-operative advertising, many firms having found that it is not only cheaper but more effective to advertise with a group of merchants in their own or related lines than it is to advertise individually. Some very interesting campaigns have thus been undertaken by groups in different cities, sometimes independently, at others in co-operation with a live newspaper. One of the best of the latter is the campaign just concluded by a group of Louisville, Ky., merchants. A dozen leading firms took a page and divided it between them. They then announced that they were in the market for ads to fill these spaces. Each week each merchant gave five dollars in merchandise to the best ad submitted to him, and that one was used as his ad for the succeeding week. Each merchant also offered a special prize for the best ad submitted during the entire contest, and the ad was chosen from the prize-winning ads submitted each week during the eight weeks of the campaign. Best of all, the newspaper under whose auspices the campaign was conducted offered a cash prize of \$75 for the best ad submitted during the eight weeks, the winner being chosen by having the twelve firms each submit their best ad, and these twelve were laid before three judges—who were among the best advertising men in the city—who selected the one that in their judgment was the most effective. Among the firms co-operating was the Baldwin Piano Co., and the text of the prize-winning ad which it submitted to the judges was as follows:

"Is your home equipped for your own pleasure, or do you have to go elsewhere for your enjoyment? Try an evening at home with a phonograph."

This text, of course, was very effectively displayed.

Up in Oregon one of the local papers, in connection with a number of leading merchants, offered a school children's popular home necessities educational contest. Nineteen dealers in conjunction with the editor of the paper offered an aggregate of \$500 in prizes for a contest extending over twenty weeks, \$25 in cash being given each week in the form of one first, second, third and fourth and five additional \$1.00 prizes. The contest was open only to children under the age of eighteen and only one prize could be won by any family—this being to distribute the prizes more widely and to prevent one gifted member of a family submitting ads under different names. The idea in the contest was to write in prose or verse an ad of not more than fifty words telling why the wares of a certain merchant should be purchased. The children were at liberty to choose any of the firms on the page, and as many as four ads could be submitted each week by any child, provided they were all concerning different firms. The Oregon Eilers Music House, Portland, was one of the participants in this contest and laid special stress on its records—the winning ads generally having reference to the enjoyment obtained from the dance and concert records rendered on the phonograph.

For all-the-year-around advertising it would be hard to surpass the plan of a group of merchants of Iola, Kan. They got together and formed an association with a duly elected president and secretary. Their first step was to get out a four-page bulletin, which they ran as an insert in the local newspaper. This prospectus stated in part:

"This particular bulletin is the first of a series you will receive regularly once a month. The purpose of it is to notify you that the merchants of Iola, whose names are mentioned herein, will hold a special sale Saturday, to which you are cordially invited.

"Every merchant announces an especially low price on some one article of common use, and, since every dealer announces a price on a different article, you will be able, by going from one to another, to make a long list of purchases at reduced prices."

C. G. Nelson, secretary of the Association, explained in detail the workings of the plan, which has been in successful operation for a year:

"The bulletin mentioned above is issued every month. Every article on the two inside pages is censored by our advertising committee and the merchandise must be a real bargain or the

*Dealers in Many Sections of the Country Find Co-operative Advertising Economical and Most Resultful*

ad is turned down. The spaces in the bulletin cost \$4.00 each. On the inside pages no advertiser can combine spaces, use cuts or name plate. This is for the purpose of giving the small advertiser the same benefit as the larger one. On the outside pages there are no restrictions—cuts and name plates can be used and any number of spaces up to four may be combined to form a single ad if the merchant wishes."

Another plan carried out by these enterprising Iola merchants to secure the rural trade is the monthly auction sale. These sales are held at a regular auction pavilion, with entrances on two streets. Household goods, farm implements, automobiles and live stock are sold on commission, the first two classes being auctioned off in the morning, the latter two in the afternoon. No

charge is made for listing goods to be sold, and free pens are provided for the live stock. A commission of 2 per cent is exacted on live stock and automobiles and 5 per cent on all other merchandise. Auctioneers are provided by the Association, but any one who wishes can bring his own auctioneer. These monthly sales have brought much trade to town that formerly went to the mail-order houses and have made for closer relationships between town and country. The John V. Roberts Music Co. was among the co-operative group and specialized on records, their offer being three double-disc records.

## TEMPLE OF MUSIC OPENS STORE

Brunswick Line Featured by Attractive New Establishment in Allentown, Pa.

ALLENTOWN, PA., July 3.—The formal opening of the Temple of Music, 940-942 Hamilton street, this city, was held late last month with daily concerts, which were well attended. This is one of the finest establishments in this part of the State and, in addition to a complete line of pianos of well-known makes, the Brunswick line of phonographs and records will be featured by the firm. The main floor of the establishment is used as a display room and the mezzanine floor has been converted into a demonstration department, a number of booths having been constructed here. The basement has been turned over to a completely equipped repair department.

## DUPLEX RADIO PHONO. CO. FORMED

The Duplex Radio Phonograph Co., of New York City, has been granted a charter of incorporation under the laws of the State of Delaware, with a capital of \$500,000.

## FILES BANKRUPTCY SCHEDULES

Talking Motion Pictures, Inc., of 203 West Fortieth street, New York City, has filed schedules in bankruptcy, listing liabilities of \$120,822 and assets of \$3,864.

**Sonora** DISTRIBUTORS EXCLUSIVELY  
for New York, Staten Island and the lower Hudson Valley

**Greater City Phonograph Co., INC**  
311 SIXTH AVE. TEL. CHELSEA 9237 NEW YORK

The superiority of the **Sonora** is as marked  
as the ease with which it sells.



Just compare any record of any make with the needle cut Pathe Actuelle and then you will know why the Pathe Actuelle is—

# The Best Record in the World

For Example, try "Stumbling"—Our Record No. 020746

*Play on any phonograph with steel needles*

Double Disc  
Classical  
Records by  
famous Artists

*Pathe*  
**Actuelle**  
REG. U.S. PAT. OFF.  
~ RECORDS  
Needle Played

Standard  
Selections  
also  
First with  
the hits

**2 for \$1.00 - 55c each**

*(59c in Rocky Mountain States)*

## Partial List of Famous Artists—

Tito Schipa  
Yvonne Gall  
Adamo Didur  
Margarethe Matzenauer  
Rudolph Ganz  
Anna Fitziu  
Eleonora de Cisneros  
Claudia Muzio  
Luigi Montesanto  
Kathleen Howard  
David Bispham  
Grace Hoffman  
Alexander Debruille  
Helen Yorke  
Roberto Rotondo

## DEALERS—

Write to us at once for information regarding the Blue Ribbon Order.

**PATHÉ FRÈRES PHONOGRAPH CO.**

20 Grand Avenue

Brooklyn, New York



# An Appealing Store Atmosphere Is Necessary for Business Growth on a Sound Basis

Probably one of the most effective methods of retaining patronage after advertising, canvassing, correspondence, window displays, etc., have done their work in bringing the customer to a mental state of desire and interest in the line handled is through the medium of an atmosphere in the store which is pleasing to the customer or prospect.

Many concerns spend large sums of money in advertising, circularization and other methods of interesting the public in their goods and then they neglect the most important element entering into the building of a successful business enterprise. As an example of this point: A man prominent in the advertising world, while reading the newspaper, was so favorably struck with an advertisement that he decided to visit the store. He had already made up his mind that he would purchase the article advertised and, although the store was a considerable distance out of his way, the influence of the ad was so strong that he could not resist its appeal. When he entered the store, instead of the high-class service suggested by the advertisement, he met an attitude of indifference that left him cold and he went out without making the purchase. The atmosphere of that establishment was repellent.

Atmosphere depends on many things; dignified and attractive arrangement of stock, cheerfulness on the part of the sales staff, quick service, honesty, courtesy, etc. A merchant can spend a fortune on his establishment and without these attributes his store will prove uninviting to customers.

A good example of store atmosphere which was favorable from the standpoint of customers

was found in a medium-sized city recently by the writer. Out of about a dozen stores visited this was the only one which could boast of a really appealing atmosphere. In the first place the store was a model of cleanliness and attractive arrangement. From the windows to the rear of the place everything was in order and, what is more important, there was no evidence of that

*Attention to Details  
Commonly Called Service  
Is Necessary to  
Hold the Unswerving  
Loyalty of Customers*

stiffness which is evident in many establishments. An interview with the proprietor was illuminating. In answer to an inquiry he explained some of his policies as follows:

"I do not tolerate anything but cheerfulness on the part of my sales staff. From experience I have discovered that the grouch is the most detrimental factor in a business enterprise. I make it a point to learn my customers' names and their likes and dislikes in the way of music, so that when they come in I can greet them as a friend and make suggestions concerning rec-

ords which I am quite sure will please them. This alone has been instrumental in building up a large and steady clientele of record customers.

"Another thing many dealers do not seem to realize is the important part children play in the selection of music. A source of great personal as well as profitable satisfaction to me is the fact that I find it easy to make friends with the children. They like to come here with their parents and I have made many record sales through the child's liking for music. Along this line also it is possible to influence the parents toward the selection of music which is bound to prove beneficial to the welfare of their children from the standpoint of education. It must be borne in mind that the majority of record customers in any community are women, many of whom have children.

"Advertising and all the other mediums for bringing the customer into the store are practically worthless unless the people are handled in the proper manner once they have been induced to enter. It is better not to have a prospect come into the store at all if he is to be handled in a manner that will arouse a feeling of dislike and distrust in the concern. It is not only the losing of that one customer, but because of the fact that the disgruntled one spreads the story of his ill-treatment or imagined slight and several other persons have been added to the list who will do their shopping elsewhere."

Theodor Chaliapin, the noted Russian singer and Victor artist, will soon leave Russia to settle permanently in the United States with his family; according to a report reaching the United States from Copenhagen.



**94.7%**

Send your record orders to Pearsall. Our stock is 94.7% perfect.

That's Pearsall Service.

Ask any Pearsall Dealer—He'll tell you

*"Desire to Serve Plus Ability"*

10 EAST 39th ST.



NEW YORK CITY

**SILAS E. PEARSALL COMPANY**

**DISTRIBUTORS**



# A Portable of Distinction

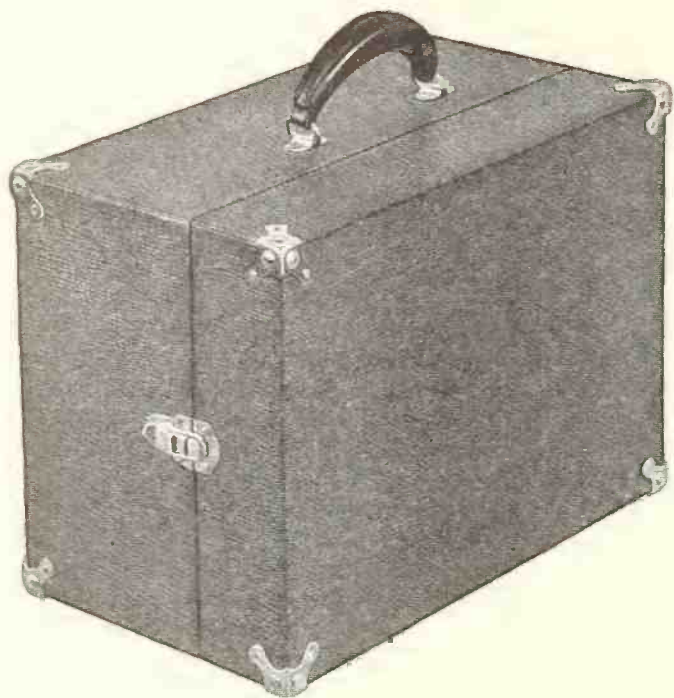

INTO the Columbia Portable Grafonola have been built the requirements of the finest musical instrument. Sturdy and compact in form, it has still all the best reproduction features of the cabinet Grafonola. From the sound chamber in the upper lid, regulated by adjustable tone leaves, there is produced a volume of tone which will surprise you. And the scientific perfection of its construction loses nothing of the sweetness and purity.

Here is an instrument that is always ready to play. Every part has been cleverly fitted into this small cabinet in the most convenient position. Lift the lid, insert the winding crank and everything is ready. The Columbia Portable will find a place of usefulness in every home. The young folks can move it to the porch for summer evenings of dancing and the children can make it their own. Its sturdy construction is made to withstand the hardest usage.

For vacation time it is an ideal partner—an asset to every outing. Music out of doors—on the river—at the summer camps—on lawn parties—picnics—what a sales vista this opens up among your customers.

Into the Columbia Portable Grafonola go only the finest selected materials and careful workmanship. You will be pleased at the perfection of detail of this instrument. Metal tops fit tightly over the needle cups when the cabinet is closed, and every part fits snugly for a journey. The handle of the case has been given a perfect adjustment, which makes carrying easy. You will not find such a list of sales features embodied in any other portable.

You can make many summer sales with this instrument that you can make in no other way. Put it on display in your windows and its appearance alone will produce inquiries. Demonstrate its compactness, its lightness, its perfect musical qualities, and sales will follow.

COLUMBIA GRAPHOPHONE COMPANY

NEW YORK



# Columbia





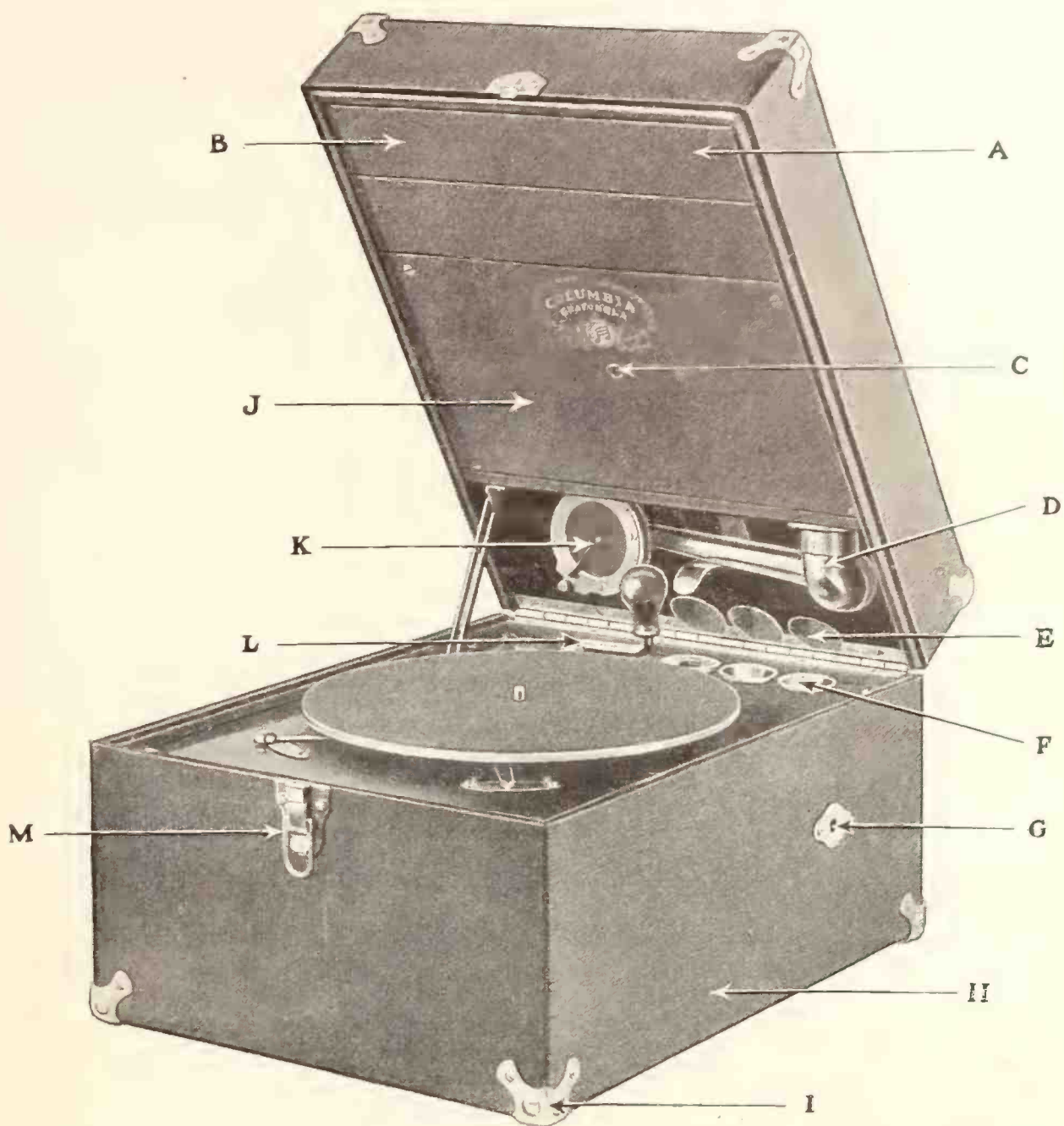

- a*—Two-pivoted tone-control leaves at the mouth of the amplifying chamber permit modifying the volume of tone as desired.
- b*—The cover encloses the scientifically shaped amplifying chamber (or horn) which permits the full and natural development of the sound-waves (as in the big cabinet Grafonolas) from the neck of the tone-arm to the mouth of the horn.
- c*—An escutcheon at this point fits over the motor pinion and secures the turntable against rattle or damage during transportation.
- d*—The standard Columbia bayonet-joint tone-arm conveys the sound-waves directly into the amplifying chamber in a continuously widening channel without obstruction or the necessity of employing special turns or adjustments to suit this type of a phonograph.
- e*—Needle cup covers seal needle cups when cover is lowered for carrying.
- f*—Three shaped nickel needle cups (one for used needles) prevent aggravating forgetfulness.

- g*—The position of the winding spindle gives the crank a wide swing which permits easy and safe winding of motor.
- h*—Complete exterior is covered with the best grade of heavy black Fabrikoid.
- i*—Heavy nickeled corner protectors give strength, withstand abuse and save scratching of furniture.
- j*—The inside is finished in highly polished Red Mahogany which, with the highly polished nickel parts and black Fabrikoid exterior, makes this instrument very attractive in the playing position.
- k*—Tone-arm and improved standard Columbia reproducer swing back without adjustment and are safely positioned by a spring for carrying.
- l*—Winding crank is conveniently positioned here for transportation.
- m*—Ingenious safety catch permits dust-proof closing of cover.

# Portable Grafonola



## The ALBUM method EXCELS all other RECORD FILING systems EVER TRIED



SELECTING THEIR FAVORITES

### To the Trade:

Our Record Album factory—all or any part of it—is at *your command*. Hundreds of customers can and will gladly testify as to the good quality of our production.

Our large and growing business is due to satisfied customers and repeat orders.

Imprint (firm name or trade mark) stamped on covers if desired when orders are sufficiently large to justify it.

OUR ALBUMS ARE MADE TO CONTAIN VICTOR, COLUMBIA, EDISON, PATHE, VOCALION AND ALL OTHER DISC RECORDS

**NATIONAL PUBLISHING CO., 239 S. American St., PHILADELPHIA, PA.**

New York Office, 54 Franklin Street, Telephone, Franklin 1227, James E. Maguire, Representative

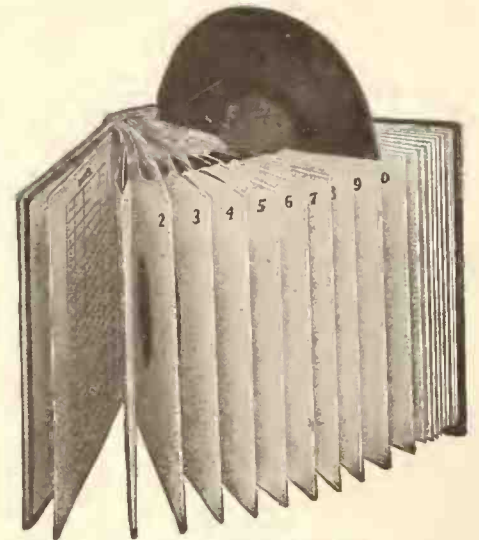

THE PERFECT PLAN

### "DAILY DOZEN" POPULAR IN SCHOOLS

Health Builders' Records Proving Boon to Many Schools—Increased Use of Talking Machines in Institutions of Learning as a Result

The talking machine has long figured prominently in the curriculum of public schools of this country, particularly in the period devoted to physical culture exercises. The advent, however, of the Health Builders' course, which is

appropriation does not allow for a physical culture director the Health Builders' course is supplying a long-felt want.

Robert B. Wheelan, president of Health Builders, Inc., New York City, has received many enthusiastic letters of commendation from school teachers in all sections of the country who are using this course in their classrooms. Many have had photographs taken and sent them in showing their classes going through the exercises. The accompanying photograph depicts the Mont-



Montross, Va., Scholars Doing "The Grind"

Walter Camp's "Daily Dozen" set to music, has materially increased the use of the talking machine in public schools for physical culture purposes.

In the Health Builders' course, constituting twelve distinct exercises, the music is not only supplied, but the instructions and commands as well. Thus while the exercises may be given under the capable direction of the physical culture director of the school the pupils, with the help of the Health Builders' course, are able to efficiently go through the entire twelve exercises under the guidance of a monitor selected from their number. In rural districts where the school

ross School, of Montross, Va., doing the "Daily Dozen" to the accompaniment of the talking machine. This period is an eagerly anticipated daily event for the children.

Talking machine dealers who retail the Health Builders' sets are bringing them to the attention of the local school boards with much success, and one dealer in Virginia recently set out in his car to visit in turn every school in the State on the proposition.

In the last analysis knowledge and the ability to apply knowledge practically is the only road to success in any job.

### MAKES RECORDS OF TRIBAL SONGS

Member of Taos Indian Tribe Aids Smithsonian Institute in Work of Preserving Historical Data—Has Made Many Interesting Records

WASHINGTON, D. C., July 8.—Rosendo Vargas, a member of the old Taos tribe of Indians of New Mexico, has been lending valuable aid to the Smithsonian Institute of Washington in its splendid work of preserving historical data. He has made a number of talking machine records of the tribal songs of his people in their native language.

These songs, including examples of every kind of singing practiced by the Taos Indians, carry the atmosphere of old New Mexico and reflect the spiritual thoughts of a tribal people that once was in a high stage of cultural development. Some of the words of the songs—expressed in a language which, although extremely complicated, is capable of expressing an infinite variety of intricate thoughts, and discloses an advanced stage of mental development—are very long and have delicate shades of meaning that are difficult to translate into English.

Many of the songs are action-songs—one of them being called a "going song," which simply means a song that is sung by the Indians when going into the fields to work or when starting out to catch their horses preparatory to going on a trip—in fact these records reveal the traits and habits of the Taos tribe.

### PHILADELPHIA INCORPORATION

Everybody's Talking Machine Co., Inc., of Philadelphia, Pa., has been chartered in that State, with a capital of \$25,000. I. B. Grabuski is the incorporator.

The Branford Music Shop, Victor dealer, was recently opened at 282 Main street, Branford, Conn.

Patented  
1914

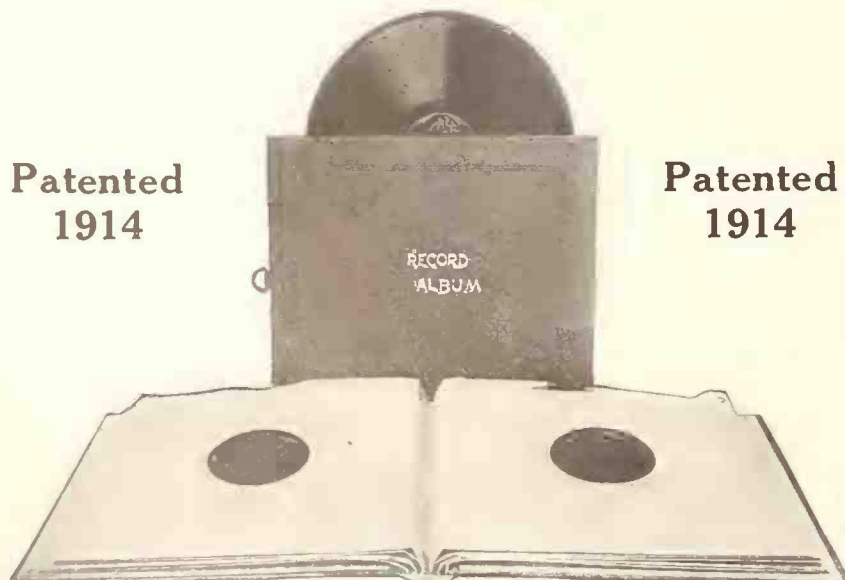

Patented  
1914

## MONTH by MONTH

The growth of the Boston Book Co.'s business has been neither hectic, spotty nor other than steady and consistent. When one stops to consider the reason, namely, that Boston albums are handled by successful merchants, who appreciate the fact that satisfied customers mean increased business, there is no room left for discussion.

Since their introduction in 1914, Boston Albums, as the trade well knows, have set the pace, for others to follow. The wise dealer takes cognizance of this fact and his business grows accordingly.

Because of their wooden backs and interchangeable leaves, **Boston Albums** are **Business Builders**. Have you sent for a sample of the latest Bostonian?

**BOSTON BOOK COMPANY**  
501-509 PLYMOUTH COURT CHICAGO, ILL.



**ATTRACTIVE INTERIOR ARRANGEMENT**

Jones Store Co., of Kansas City, Designs Unusually Practical Arrangement of Service Counters and Demonstration Booths

KANSAS CITY, KAN., July 3.—The Jones Store Co., of this city, now has one of the most attractive and convenient talking machine departments in this part of the country. It is in striking contrast to what the department was the first of the year when C. R. Lee, the present manager, took hold of it. The principal change has been in arranging the booths around the space,



View of Jones Store Co. Warerooms and in the center of the space, building in the counters and record files.

These counters are in easy reach of all the booths and have openings so the clerks can get in and out readily to serve the customers. In the racks there are spaces for 12,500 records and they are well filled up at this time. When Mr. Lee took up the work the stock of records consisted mostly of the current month's supply, but since then he has filled up his files, and now claims to have every record the Victor Co. puts out that he can get from his jobber. In addition to this he has on hand something over 1,500 Columbia records.

The department is now well supplied with Victor, Columbia and Sonora models and the case for parts and needles is well stocked up. In fact, the management of the Jones Store Co. has given Mr. Lee a free hand in building up the department, and he has used his opportunity to the limit. Mr. Lee is assisted by Mrs. Marie Walker, formerly of the Park Music Co., of Hannibal, Mo., and Miss Vera Kelly, until recently with the Peck Dry Goods Co., of this city. The talking machine department is situated just off the woman's rest room and furnishes concerts for the people who gather there. One of the features of the Jones stores are their very complete mailing lists, which are used to push the talking machine business, as well as other departments. This department of the work is under the direction of a former employe of the post office and he is wonderfully efficient. He now has a list of 6,800 talking machine owners and 60,000 names.

**GOOSMAN CO. BUYS STARR STORE**

Starr Piano Co. Closes Out Toledo Branch in Line With New Policy—Goosman Piano Co. Secures Local Agency for Starr Line

TOLEDO, O., July 1.—The Goosman Piano Co., 314 Jefferson avenue, this city, has purchased the entire stock of pianos, player-pianos, talking machines, etc., of the local branch of the Starr Piano Co., of Richmond, Ind. The Starr branch has been located at 318 Jefferson avenue for twenty years.

The closing out of the local Starr store is in line with the policy of the company of establishing agencies where the concern does not have proper representation and of closing out stores where the agency can be placed with reliable and aggressive concerns, according to R. E. Taylor, district manager of the Starr Piano Co.

The Goosman Piano Co. has been established since 1912 and was but recently granted a charter of incorporation. At a meeting of the stockholders of the company it was decided to increase the stock to \$100,000, the additional capital being necessary to finance the combined stores operated by the company.

**RECORD TRADE WITH THE INDIANS**

How J. F. Neece, Jr., Has Established a Demand Basis of Twelve Records Per Order in Oklahoma Territory—Doing Big Victor Trade

OKMULGEE, OKLA., July 8.—James F. Neece, Jr., has established a remarkable record for selling records to the Indian residents in this section of the country. He is known to them under various familiar titles or cognomens and has established a demand on the basis of not less than twelve records per order. In other words, his Indian customers have been educated to buying in dozen lots, the same as in buying razor blades, etc. Mr. Neece is manager of the Carney-Neece Music Shops, which operate in both Okmulgee and Henryetta, Okla. This concern is doing a \$5 per capita Victor business in the territory it serves, principally through new applications of proved selling ideas.

If you have a job to do attend to it promptly and make a good job of it or let someone else attend to it who knows how.

**INGLEWOOD MUSIC CO. OPENS STORE**

New Grafonola Shop in Coast City Under Management of Carroll Scroggs

INGLEWOOD, CAL., July 3.—The Inglewood Music Co., a new concern, recently opened an attractive store in which the Columbia line of machines and records is featured exclusively. The store has been handsomely fitted up with the most modern fixtures obtainable and an aggressive campaign in the interest of the Columbia Grafonola is under way. In addition to machines and records pianos are handled. The establishment is under the management of Carroll Scroggs, who has had a wide experience in the talking machine field and is well known to the trade in this section of the country.

**REGULAR VICTOR DIVIDEND**

The Victor Talking Machine Co., of Camden, N. J., has declared the usual quarterly dividend of \$10 per share on common stock, payable July 15, to stock of record June 30.

# HARPONOLA

*The Phonograph with the "Golden Voice"*



## Announcing A Superb New Line of Models

Words fail in describing the new HARPONOLA models, just produced.

The beauty of this line, together with our price quotations, constitute a combination that is simply unbeatable.

Information will be ready for dealers and jobbers by the time this announcement appears.

Write or wire for the Harponola Proposition at once, it's a profit-maker that you can't afford to overlook.

**THE HARPONOLA COMPANY**

101 MERCELINA PARK  
CELINA, OHIO

*Edmund Brandts, President*



# TOTEMS

## *The Totem—*

Likeness of a bird or beast used by Indians as a symbol for family or clan . . . .

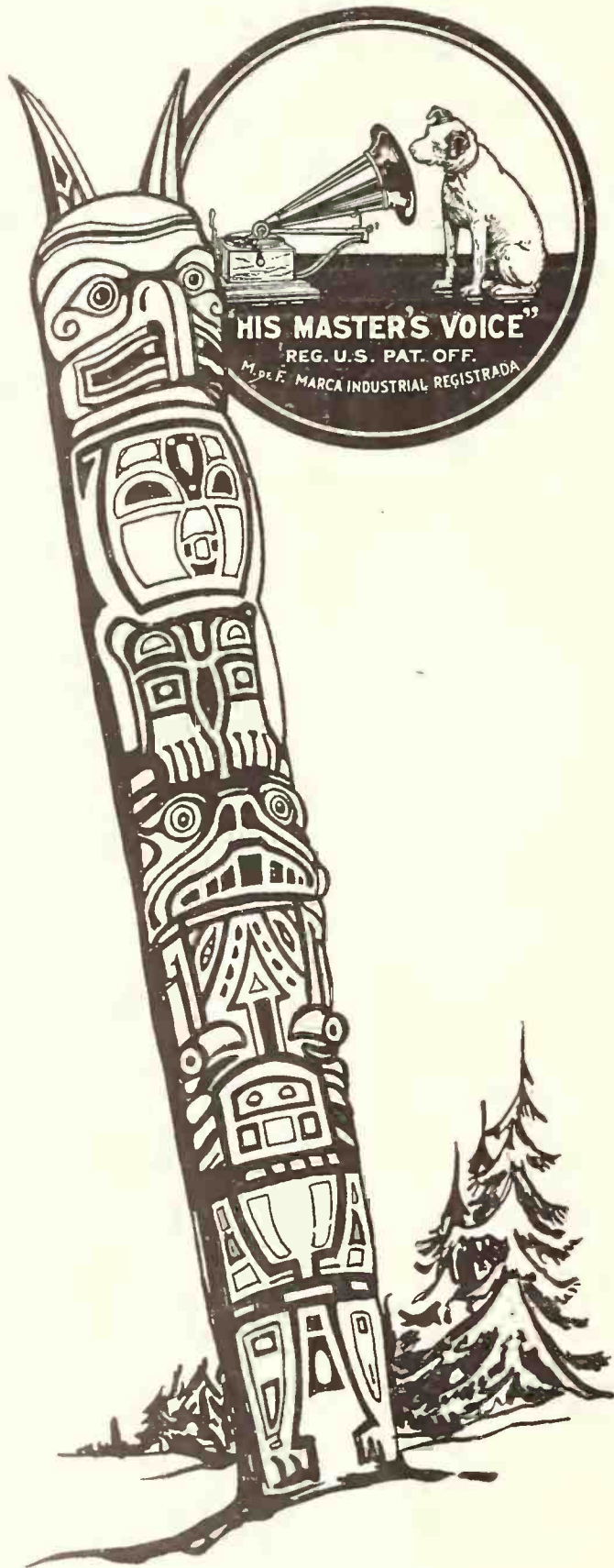

THE Indian Chief displays in the most prominent place before his house, a sign by which he is proud to be known — his Totem. In the Indian picture language it gives the history of his family, and represents the great achievements of his clan.

Victor dealers have a Totem. It means no less to them than does the Indian chief's totem. The Victor dog, listening at the horn, tells in civilized picture language a more wonderful story than ever an Indian totem could hope to tell. It tells of a line of merchandise that, for a generation, has unfailingly demonstrated its quality, its dependability and its beauty in every corner of the earth. In every clime, and by every race the unimpeachable sincerity of Victor products is recognized, and the symbol is that modernized totem—the Victor Dog.

The right to use it is surely something to be highly treasured. Victor dealers should respect the Victor Totem and be ready to defend it against unfair competition.

The name Blackman is our Totem reflecting in Service all that the Victor Totem does in manufacture.

*Blackman*  
TALKING MACHINE CO.  
28-30 W. 23<sup>RD</sup> ST. NEW YORK N.Y.  
VICTOR WHOLESALE DISTRIBUTORS



# A Thorough Knowledge of Operating Costs Reduces Danger of Undercharging

By Thornton Hall

About a year ago there was a small musical instrument store in a busy section of upper New York. This store was notable for the almost constant stream of customers who daily entered the establishment and who purchased liberally. It was located in one of New York's uptown shopping streets which has many talking machine, piano and musical instrument stores, but this little shop seemed to do a business that was decidedly more than its share.

The reason for its phenomenal sales record was its low-price policy. Merchandise was offered at figures drastically below the ordinary level in force in the neighboring shops. It was the price concessions that drew the customers into the store. Business was apparently unusually good. It was so good, in fact, that the sales manager of one of the companies whose product was handled by the dealer paid him a visit one day to find out how he was doing it. He spent a day in the store, observing the sales activities of the clerks and noticing how business was done. He plied the proprietor with a number of important questions.

"Just as I expected," was the sales manager's report upon returning to the office. "Although he does not know it, he is losing money on every sale he makes. He keeps no record of costs and has no idea of how much it is costing him to do business. I predict that in a year's time he will be out of business."

He was right, except that the dealer is still doing business. He is doing it on a different basis, however, and while the bargain-hunting crowd is no longer storming his doors he is doing a tidy little business at legitimate, profit-allowing prices.

Just as the sales manager predicted, there eventually came a time when this dealer found that he could not keep on eating his cake and having it, too. He came to the manufacturer and asked to have an extra extension of credit. The reply was that credit would be extended only upon the absolute acceptance of very stringent conditions. The panicky dealer would have accepted any conditions, so with the credit terms went one of the company's accountants, who introduced into the

modern method of storckeping. His new selling prices were to be arrived at by adding to the cost of the merchandise the exact (no guesswork) cost of selling it and a fair profit. The important points in the system he is now using successfully are well worth the consideration of other dealers.

The first item he keeps a record of is the expense of buying. All of the buying is done by himself and one of his more reliable clerks. He is able to estimate fairly accurately the amount of time spent by each in the duties of buying merchandise, and a proportionate amount of the salaries is allotted to this expense. Under this head he places all time consumed in examining stock, making stock records, ordering goods, inspecting salesmen's samples, interviewing salesmen and making buying trips. Traveling expenses in quest of merchandise, of course, are included.

Then there is the item of selling expense, and a large item it is. First, under this head come salaries and wages of the members of the sales force. All of the time devoted by buyers or the proprietor or any other member of the organization to selling effort should be included in this item and properly charged to selling expense. Whatever method is used in paying sales employes it must all be figured in. Premiums or prizes of any sort, commissions on volume of sales or bonuses must be added to the salaries or wages and applied to the expense of selling the merchandise.

Then there is the matter of advertising, the cost of which is quite properly a selling expense, and must be so reckoned. According to modern standards of musical instrument merchandising

(Continued on page 22)

*The Dealer Who Keeps a Record of the Cost of Doing Business Increases His Chances of Making a Success*

establishment a rigid system of cost finding. Every little item in the cost of retailing musical instruments was included and the merchant began to learn how he had been losing money while his sales were so great.

Gradually he began to realize what a fool he had been and with this humiliating realization came a determination to prove that he could make good on a new basis. This new basis was the

## Improve Your Service AND Increase Your Sales

### By Equipping With The OGDEN "UNIT" or Sectional System

which has been used by thousands of dealers for the past six years and "Sold" to all on our UNCONDITIONAL GUARANTEE OF SATISFACTION, QUALITY AND PRICE.

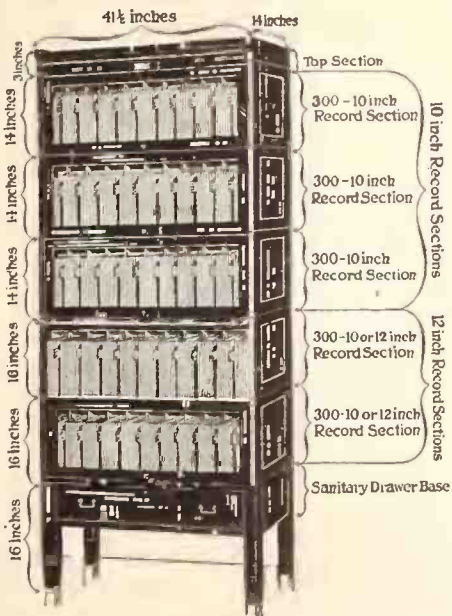

Model No. 1 and No. 31 Sectional Cabinet

FILES YOUR RECORDS so you can find them for QUICK SALE and SERVICE. Fits any space and Stock. Visible Tab Indexes locate every Record Instantly. \$14.00 per 1,000.

## ORDER PORTABLE VICTROLAS NOW

and be ready to "Tie Up" with National Advertising and "Cash In" this opportunity for an extra profit by Selling

### OGDEN STAND YOU-NITS

For the Portable Victrola No. 50, Also No. IV and No. VI

Don't wait but be ready and go after the Summer Business with a VICTROLA-STAND OUTFIT for Sea Shore or Camp,—Town and Country, with Music for every Occasion.

Order a Stand for every Portable Victrola (to Match) and we will Guarantee the Sale if only Displayed and Advertised.

#### Positively Rigid and Strong

Matches the Victrola in Material, Finish and Design. If your Jobber does not have Stock order direct and we will deliver them FREE.

Improved Model No. 50a is a dandy.

Delivered \$7.00 each

Write for New Catalogue and Cuts free.

OGDEN SECTIONAL CABINET CO., Inc. LYNCHBURG, VA.

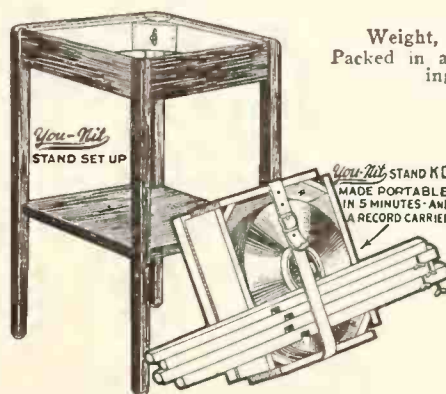

Weight, each, 10 lbs. Packed in a Portable Carrying Case.

Six Pieces Assembled or "Packed Down" as a Record Carrier in Five Minutes

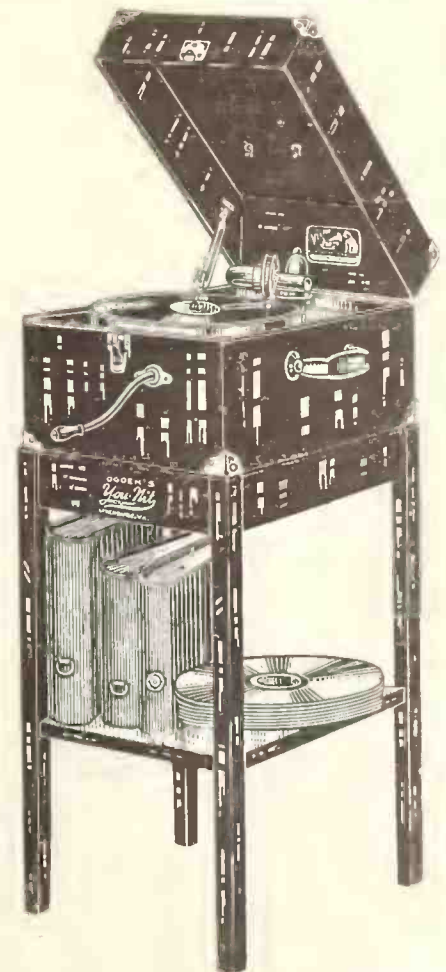



## KNOWLEDGE OF OPERATING COSTS

(Continued from page 21)

advertising expense is considerable. The pre-sale cost of advertising, however, is not so very large, for a large advertising expenditure means a rapid turnover. In the cost of advertising should be included all money spent for newspaper and periodical advertising, circulars and letters for sales promotion, billboards and electric signs, theatre and other local entertainment programs, gifts, premiums, trading stamps, coupons, etc.

There are a number of miscellaneous items hard to classify that should be charged to selling expense if the dealer is to keep an accurate cost record that will enable him to fix his prices properly. Such things as wrapping paper and twine must not be forgotten. Many times goods come back for alterations and repairs without charge. These alterations and repairs must be paid for by the store and are a proper part of sales expense. Also there often will be returned articles which entail a certain amount of expense and loss—a natural part of selling expense.

All of these various selling expenses must be carefully recorded if you would run your store on a systematic basis and keep any sort of intelligent tabs on your business. They must all be lumped each month and a pro rata allotment made to each machine and article of merchandise that you carry.

Besides buying and selling expense, most dealers also have the item of delivery expense. This includes the wages of such of your help engaged in delivery work for the actual time devoted to this part of the business, stable or garage expenses, by which it is meant to include the cost of operating the truck in delivery of merchandise. Whenever a dealer uses his own car in delivering merchandise he should not fail to estimate the operating and depreciation costs incurred during the time spent in delivery and charge these costs to this item. Express, mail and freight shipments must be listed under this head, as well as miscellaneous expenses that every dealer knows will occur from time to time.

Then there are certain expenses in the operation of any retail store that properly come under

the head of management expenses. This will include such effort as hiring and training employes, supervising their work in the store and other managerial duties. Such portion of the time of the proprietor or manager as is spent in these duties should be recorded as management expenses.

Office expenses are fixed and include the salaries of bookkeepers and stenographers, or the salaries of other clerks for that portion of their time that they may spend in these duties. They include also the salaries and wages of cashiers, inspectors and office messengers. The cost of office supplies comes under this head, including stationery, printing, postage, account books, etc.

There are certain definite fixed charges that should be grouped together. Rent must be charged, whether the dealer owns his own store or not. This seems quite obvious, but it is surprising to discover how many dealers are placing false profits on their books because they omit to allow for rent on buildings that they own themselves. Rent includes both the store premises and storage warehouse. This group of charges includes heat, light, power and insurance, fire, burglary, fidelity, plate-glass, employer's liability, elevator accident, sprinkler system water damage, warehouse, merchandise en route, life insurance payable to firm. Another important item is that of taxes on the property, stock and store equipment.

A charge must be estimated for the cost of upkeep and depreciation, both of store and of stock. This will include repairs and renewals of equipment and depreciation of equipment and merchandise stock.

In concluding a list of charges that must be made in accurately recording the expenses of operating a musical instrument store mention must be made of a few miscellaneous expenses that are bound to be incurred. The individual merchant will best know what these charges are likely to be in his particular store. They will probably include telephone and telegraph service, water and ice, care of the store, including janitor's service, cleaning, tips, etc.

The above review of store-operating costs shows a great many items that are very often neglected by dealers in estimating their expenses. Too many retail failures are due to inefficient cost keeping. False profits very often give a false sense of security and lead to the practice of pricing merchandise on a basis that allows an insufficient profit. The writer suggests that those dealers who maintain an accurate cost system go over this system with the various points made in this article. For those dealers who employ the hit-or-miss system of estimating operating costs the points made in this article will serve as the basis for installing a very good, workable system.

### MALCOLM MUSIC HOUSE OPENED

FLINT, MICH., July 4.—The Malcolm Music House, which for the past six years had been located at 113 East Kearsley street, this city, is now located in attractively arranged new quarters on West Kearsley and Buckingham streets. The third floor of the establishment has been turned over to the display of talking machines. Modern equipment has been installed, including sound-proof demonstration booths, record racks and service counters.

### CANARY MASTERS JAZZ MUSIC

Peggy, a canary belonging to Mrs. G. R. Farley, of Seattle, has mastered jazz. This high-bred bird of the German roller variety for years has discoursed the best quality of bird music, but the advent of some jazz whistled records into the home turned the classically educated brain into a syncopated one.

Now every day Peggy nearly drives her dainty mistress frantic by such tunes and antics.

In addition to imitating the syncopation of the latest productions, Peggy has a habit of joyfully dancing a rhythm, hopping up and down on her swinging perch, or leaping to the floor of the cage and back to the swing.

## WIDENER (N. Y.) Sells 1,003 GRANBYS

### GRANBY EDITORIAL LETTER

#### Number Four

From Granby Phonograph Corporation, Newport News, Va.

"In a period of one year, beginning the last half of 1921 and continuing up to this day (May 25, 1922) we have sold exactly one thousand and three (1003) Granby Phonographs." This is the statement made on May 25 by Mr. Speare, Manager of Widener's, 4 West 37th Street, New York.

When asked to explain his selling methods, Mr. Speare replied:



"We push the Granby because we are in business to make BIG PROFITS right NOW. We push the Granby because it also builds for us bigger FUTURE PROFITS.

"For instance: The Granby owner grows used to the beauties of the full round tone. When she (or he) hears a different machine, with a less resonant tone, the boosting begins. She tells the owner of the other machine how much nicer her own is—and tells it enthusiastically, because she has noticed the decided difference in the roundness of the tone, and that makes

her realize just WHY she likes her Granby better. This starts her talking.

"I don't mean to say that Granby owners go around talking all day long about their machines," Mr. Speare continued, "That wouldn't be true.

"But the fact is, WHEN THE SUBJECT COMES UP a Granby owner is right Johnny-on-the-spot to tell how different the tone really is! 'As Mellow as Southern Moonlight' is how they say it in the ads.

"Another odd thing I discovered is that the old owner is a better word-of-mouth advertiser than the new owner. The old owner has heard the Granby more often, and therefore has a BETTER MEMORY of the individualities of the tone—and so when she hears another machine, she UNDERSTANDS WHY she likes her own machine better. That is why she boosts.

"We sold 1,003 Granby Phonographs in our first year, just ended. We reached this figure not alone because we ourselves made more money on each machine sold and therefore PUSHED IT, but also because we had first 100, then 200, then 400, then 700, and now 1,003 boosting owners doing WORD-OF-MOUTH ADVERTISING in New York for the Granby."

The Granby proposition is a very liberal one, with BIG PROFITS, and terms that we shall be glad to give you when you write for them. Write now, and say, "Explain, please, the big profits and liberal terms offered by the Granby Corporation."

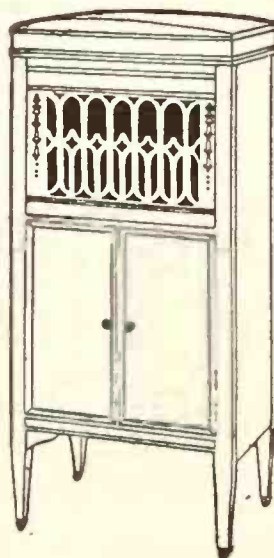

GRANBY No. 13, \$135

"Especially popular,"

says MR. SPEARE

## GRANBY Phonograph CORPORATION

Capital, \$2,500,000.00

Offices and Factory

Newport News,

Virginia





HERE IT IS!

*The*  
**FLETCHER UNIVERSAL  
 TONE ARM and REPRODUCER**

Gives Proper Playing Weights for All Records. No Adjustment Screws or Springs  
 SAMPLES \$8.00 Specify 8½" or 9½" arm

**FLETCHER-WICKES CO., 6 East Lake Street, Chicago, Illinois**

*THE McLAGAN PHONOGRAPH CORPORATION, LIMITED, STRATFORD, ONTARIO, EXCLUSIVE CANADIAN AGENTS*

**TONE ARMS**  
*Fletcher*  
 REG. TRADE MARK  
**REPRODUCERS**

*Fletcher*  
 REG. TRADE MARK



Reproducer  
 and Connection  
 for  
**NEW EDISON**  
 Plays all Records

*Dealers, Send for  
 Prices and Terms*

**FLETCHER-WICKES CO.**

**6 East Lake St., Chicago, Ill.**

*THE McLAGAN PHONOGRAPH CORPORATION, LIMITED, STRATFORD, ONTARIO, EXCLUSIVE CANADIAN AGENTS*

SOMETHING ENTIRELY NEW IN TONE ARMS  
**THE FLETCHER "STRAIGHT"**



**STRAIGHT INSIDE—Taper Outside**  
**BALL BEARINGS THROUGHOUT**  
**NEW DESIGN NEW CONSTRUCTION**

Yes, it is universal and equipped with the Regular Fletcher Reproducer, giving the same natural tone quality as heretofore

Made in two lengths, 8½" and 9½"

SEND FOR PRICES AND TERMS

**FLETCHER-WICKES COMPANY**  
**6 EAST LAKE ST. CHICAGO**

*THE McLAGAN PHONOGRAPH CORPORATION, LIMITED, STRATFORD, ONTARIO, EXCLUSIVE CANADIAN AGENTS*



# Determining Realized and Unrealized Profits on Instalment Sales :: :: :: :: By M. L. Seidman, C. P. A.

of Seidman & Seidman, Certified Public Accountants

The method of determining income on instalment sales is the most perplexing problem with which instalment dealers have to contend when preparing income tax returns or computing profits. Mr. Seidman points out in a simple, yet precise manner, by means of practical illustrations, just how readers may take fullest advantage of the rulings of the Revenue Department in keeping their books.—EDITOR.

The Internal Revenue Department has raised a question in a number of instances as to the accuracy with which instalment dealers determine realized and unrealized profit on instalment sales. In a number of cases the Treasury Department has thrown out entirely the right of instalment sales dealers to report their profits on the basis of cash collected from instalments instead of the full sales price, because these dealers could not definitely establish the exact facts in connection with when the profits were finally realized.

The question the Internal Revenue Department raised rests upon the proper method of determining what year's unrealized profit reserve is affected when cash is collected on account of an instalment contract. The usual practice of instalment dealers is to set up a reserve for unrealized profit on account of uncollected instalment sales measured by the uncollected gross profit on such sales. For different years this unrealized profit might be a considerably different percentage. The following is a typical example:

	1918	1919
Sales .....	100%	100%
Cost of Sales .....	70%	50%
Gross profits to be realized .....	30%	50%

In setting up the reserve for unrealized profit for the various years in question an instalment dealer should include all sales made for which cash has not been collected. For the year 1918, the above case, for instance, this reserve would be thirty per cent of the sales price of uncollected instalment contracts entered into during 1918. In 1919 he would set up fifty per cent, etc.

The trouble has been that when cash is finally collected on the instalment sales for these various years dealers have not tried to determine what year the cash collection applied to, but usually computed the realized profit on such cash collection on the current year's gross profit percentage. It is to this method that the Internal Revenue Department objects.

A number of ways have been suggested to determine the year against which cash receipts apply. Most of them, however, are very cumbersome and impractical of operation. For instance, a number of instalment houses are attempting to designate each check as it comes in with the year against which it applies. It is apparent

what an enormous job this is where a large number of customers are on the books and how expensive and impractical this method is in getting at the facts.

It will be noted that in order to properly ascertain the annual profits when a dealer keeps his accounts on an instalment basis for income tax purposes it is necessary to know the following:

- 1—The amount of instalment sales made during a given year.
- 2—The amount of cash collected during a given year and the year or years to which the cash collections apply.
- 3—The determination of gross profits to be realized on the instalment sales made during a given year and the amount of such sales uncollected at the end of the year.

The following method is submitted as one that will meet the requirements of the Internal Revenue Department and gives the above information in practical and acceptable form:

It should be noted that permission to report on an instalment sales basis was not granted until a comparatively recent date. Very few instalment dealers therefore reported on the unrealized profit basis until the year 1918. In this respect, the department has ruled that where a dealer has previously been reporting his sales in full in the determination of taxable profits such taxpayer when changing to an instalment sales basis does not have to report the cash collections received on account of sales of prior years in arriving at his taxable income. The reason for this is obvious. The reporting of a sale as realized profit has resulted in paying the tax at that time and therefore to take the cash collection on such sales in again as profit to be accounted for would make a duplication in taxation.

Assuming, therefore, that an instalment dealer begins reporting on a "cash" or "unrealized profit" basis beginning with the year 1918. As of January 1, 1918, therefore, all instalment accounts receivable represent items upon which the tax has already been paid. All such accounts collected subsequent to January 1, 1918, should therefore not be included in the tax calculation for such subsequent year.

For example, assume that X Furniture Co. had outstanding on instalment accounts as of Jan. 1, 1918 .....

That during the year 1918 it sold on instalment contracts, which included sales both to customers that had balances on the books as of Jan. 1, 1918, as well as to new customers opened during the year 1918 .....	\$180,000.00
That during the year 1918 cash or its equivalent was received from the old customers on their old accounts and on their new purchases for 1918 as well as from the new customers for sales during 1918. The total amount for all being .....	300,000.00
	\$230,000.00

At the end of the year, therefore, there was a balance outstanding for instalment contracts in the amount of \$250,000, made up as follows:

Instalment accounts receivable Jan. 1, 1918 .....	\$180,000.00
Instalment sales, 1919 .....	\$300,000.00
Instalment cash collected, 1918 .....	\$230,000.00
Instalment accounts receivable Jan. 1, 1919 .....	\$250,000.00

It is apparent that the outstanding accounts receivable as of January 1, 1919, are made up of two classes, as follows:

1—Accounts outstanding as of January 1, 1918, which are still outstanding on January 1, 1919, but which balance has been either increased or decreased during the year 1918 by purchases and payments.

2—Accounts newly acquired during the year 1918 resulting in a balance at the end of the year 1918 for transactions which occurred wholly during the year 1918.

The problem confronting us is to determine how much in dollars and cents of the instalment accounts receivable that were outstanding January 1, 1918, were still outstanding on January 1, 1919. If we determine that factor we can then tell what portion of our collections or other receipts for the year 1918 went to pay the balance outstanding as of January 1, 1918. In that way we can determine how much of the collections apply to sales prior to 1918 and how much to 1918.

To arrive at these figures the following method is suggested:

When taking a trial balance of the instalment accounts receivable ledger as of January 1, 1919, instead of showing only the balance of each account, it is shown in five columns, as indicated in Tabulation No. 1, at bottom of this page.

It will be noted from this tabulation that we have the following information:

(Continued on page 26)

Account	Balance Jan. 1, 1918		1918		Balance Jan. 1, 1919	
	Dr.	Cr.	Dr.	Cr.	1917 Accounts	1918 Accounts
John Smith .....	\$ 200.00					
Jas. Brown .....	300.00	\$ 100.00	\$ 250.00	\$ 100.00	\$ 50.00	100.00
Henry James .....	100.00	100.00	200.00	100.00	100.00	100.00
Tom Whitson .....	75.00	200.00	100.00	175.00	225.00	200.00
Wm. Roe .....	300.00	250.00	100.00	100.00	200.00	200.00
John Kelly .....		200.00	125.00	175.00		
Alfred Ames .....	500.00	300.00	100.00	100.00		
L. Harding .....	400.00		400.00	100.00		
		500.00	900.00			
Total .....	\$180,000.00		\$230,000.00	\$ 70,000.00		
	Balance	\$300,000.00			\$180,000.00	



**The General Phonograph Mfg. Co.**  
**Model "E"**  
**TABLE PHONOGRAPH**  
*The Greatest Value on the Market*  
 IMMEDIATE DELIVERIES IN ANY QUANTITY  
 Plays All Makes of Records  
 Superior Tone Quality  
*Write for our Proposition*  
**The General Phonograph Mfg. Co.**  
 ELYRIA, OHIO



# The Swanson

## PORTABLE PHONOGRAPH

### It's A Marvel

The only portable on the market equipped with a wooden tone arm, the recognized acme of perfection in tone production. Standard double spring Heineman No. 36 motor, high-grade sound box and speed regulator. Needle containers at right of turntable.

Compact, attractive and absolutely fool-proof. No clamps, hinges or push buttons to get out of order. Furnished in handsome black case and equipped with record album.

The lightest portable ever manufactured; a *real portable*.

Weight—15¼ lbs.

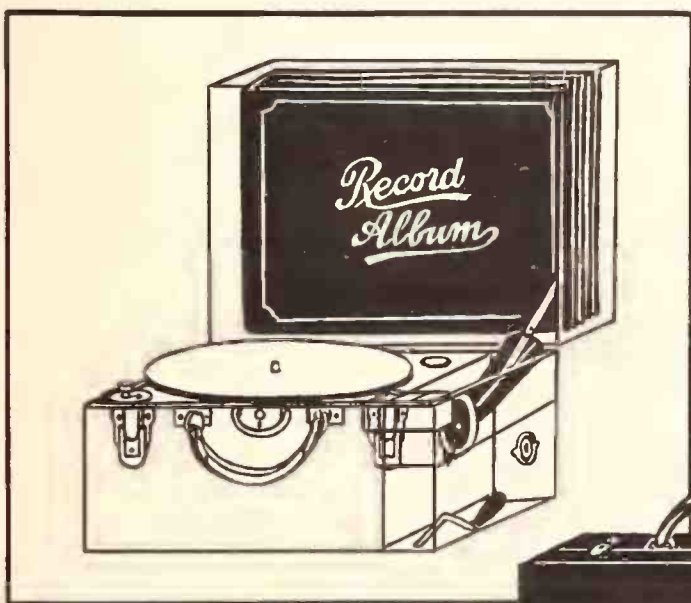

Phantom View—showing each part in place ready for carrying



The Swanson—ready for playing

List price of the SWANSON — \$40. Unusually liberal discounts to live jobbers and dealers. Write our nearest sales office for details.

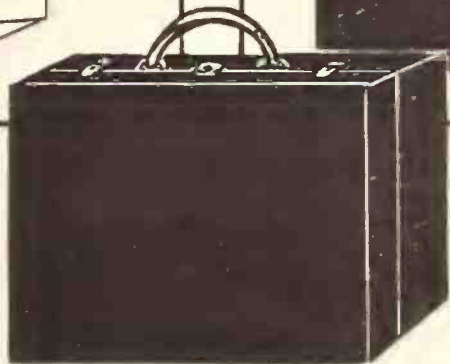

Weight complete, 15¼ lbs. Dimensions, 11½" x 13" x 7½"

We have an exceptionally attractive sales proposition for successful established jobbing houses. *Wire* our nearest office today. Territory now being allotted.

## Swanson Sales Company

R. W. MOON, General Manager

1133 Broadway  
New York, N. Y.

308 West Ontario Street  
Chicago, Ill.

536 Merchants Nat'l Bank Bldg.  
Los Angeles, Cal.



DETERMINING REALIZED AND UNREALIZED PROFITS ON INSTALMENT SALES—(Continued from page 24)

1—The balance of each account outstanding on January 1, 1918.

2—The debits or purchases made during the year 1918.

3—The credits or cash receipts from each customer during the year 1918.

4—The balance outstanding on each customer's account for purchases made up to January 1, 1919, and still unpaid for, showing the amount unpaid on account of the current year's purchase and the amount applicable to prior years.

In arriving at our balance applicable to each year we assign the credits on payments during a given year as applying to the last balance until such balance is wiped out rather than applying any of it to the current year's purchases. This is in accordance with the ruling of the Internal Revenue Department, which reads as follows:

"In case of continuous accounts covering sales of personal property, the income from which is reported on the instalment plan as provided in T. D. 3082 (C. B. 3, p. 107), the cash payments received should be allocated in accordance with the generally recognized principle of law governing such cases—that is, that failing application by the vendee, the cash payments should be applied to the earliest items of the account."

Thus applying this fundamental ruling to the above facts, we can arrive at the collections for the year 1918 made on account of sales prior to 1918 as follows:

Instalment accounts receivable outstanding as of Jan. 1, 1919	\$180,000.00
Instalment accounts receivable outstanding Jan. 1, 1919, which were outstanding on Jan. 1, 1918	70,000.00
Difference representing cash collections on account of Jan. 1, 1918, balance	\$110,000.00

Thus we know that in the total cash collections or other credits of \$230,000 from instalment accounts receivable for the year 1918, \$110,000 was collected on account of purchases made prior to January 1, 1918, and \$120,000 on account of purchases made during the year 1918. With that information we can calculate our realized profits on the sales for the year 1918 and eliminate from our calculation as untaxable the cash collected during the year 1918 on account of prior years as follows:

Instalment sales, 1919	\$300,000.00
Collected portion	120,000.00
Uncollected portion	\$180,000.00
Gross profit to be realized	30%
Reserve for unrealized profit for the year 1918	\$ 54,000.00
Portion sales 1918 realized in profits—30% of \$120,000.00	\$ 36,000.00

It will be noted that we have automatically by a simple analysis of the trial balance arrived at

Account	Balance Jan. 1, 1919		1919		Balance Jan. 1, 1920		1919
	1917 Accts	1918 Accts	Dr.	Cr.	1917 Accts.	1918 Accts.	
John Smith		\$ 50.00	\$ 75.00	\$ 50.00			\$ 75.00
James Brown	100.00	100.00	50.00	150.00		\$ 50.00	50.00
Henry James		100.00	80.00	125.00			55.00
Tom Whitson		225.00	50.00	175.00			100.00
William Roe	175.00	200.00	50.00	100.00	\$ 75.00	200.00	50.00
John Kelly		200.00		150.00		50.00	
Alfred Ames	100.00		200.00	200.00			100.00
L. Harding			100.00	10.00			90.00
<b>Total</b>	<b>\$70,000.00</b>	<b>\$180,000.00</b>	<b>\$250,000.00</b>	<b>\$260,000.00</b>	<b>\$23,000.00</b>	<b>\$85,000.00</b>	<b>\$132,000.00</b>

the distribution during the year 1918 of cash and other receipts divided as between the portion applicable to the current and previous years.

It will be noted from the above that our instalment ledger trial balance as of January 1, 1919, shows the balance of each outstanding account divided as to whether that balance is applicable to the period ending January 1, 1918, or January 1, 1919. In other words, we know that of the \$250,000 of account outstanding as of January 1, 1919, \$70,000 is outstanding on account of sales prior to January 1, 1918, and \$180,000 on account of sales made during the year 1918.

In order to show the workings of this method for subsequent years we will assume the following:

The X Furniture Co. made instalment sales during the year 1919 of	\$250,000.00
That it made collections on instalment accounts of	\$260,000.00
And therefore had a balance of instalment accounts receivable as of Jan. 1, 1920, of	\$240,000.00
(\$250,000.00 outstanding Jan. 1, 1919, plus sales less collections.)	
That the gross profit to be relied on the instalment contracts on account of sales for the year 1919 is	50%

We proceed by taking off our instalment contract trial balance in the same manner as illustrated previously except that our opening balance will be carried forward in two columns showing the 1918 and 1919 balance separately, then showing the debits and credits for the year and the balance outstanding on January 1, 1920, dividing this balance between January 1, 1918, and January 1, 1919, and January 1, 1920, accounts. Tabulation No. 2, at top of page, brings out these points.

The distribution of the \$240,000 accounts receivable as of January 1, 1920, is therefore as follows:

Outstanding since Jan. 1, 1918	\$ 23,000.00
As of Jan. 1, 1919	85,000.00
Outstanding as of Jan. 1, 1920	132,000.00
<b>Total</b>	<b>\$240,000.00</b>

From these figures we arrive at the distribution of the collections for the year, as follows:

Accounts receivable outstanding Jan. 1, 1919, account of sales previous to 1918	\$ 70,000.00
Accounts receivable outstanding Jan. 1, 1920, applicable Jan. 1, 1918	23,000.00
Difference representing cash receipts on account of sales prior to Jan. 1, 1918	\$ 47,000.00
Outstanding accounts receivable Jan. 1, 1919, on account of 1918 sales	180,000.00
Outstanding accounts receivable Jan. 1, 1920, on account of Jan. 1, 1919, balance	85,000.00
Difference representing cash collections on account of 1918 sales	95,000.00
Instalment sales of 1920	250,000.00
Outstanding accounts receivable as of Jan. 1, 1920, on account of such sales	132,000.00
Difference representing cash collections on account of 1919 sales	118,000.00
<b>Total collections, 1919</b>	<b>\$260,000.00</b>

We can now determine our gross profit for tax purposes from the above figures as follows:

Gross profit realized on account of collections applicable to period prior to Jan. 1, 1918, on \$47,000.00 cash collections	None
Gross profit realized on account of 1918 collections, 30% of \$95,000.00 (reserve for unrealized profit rate set up in 1918)	\$ 28,500.00
Gross profit realized on 1919 collections, 50% on \$118,000.00	57,000.00
<b>Total gross profit for taxable purposes</b>	<b>\$ 85,500.00</b>

The above method can be continued from year to year in the same way as illustrated above, keeping account of the balance outstanding as at the beginning of each year distributed into various years to which the balances are applicable.

The question might be raised as to the effect of the method outlined above of "reverts" and other similar credits that might be made to instalment contract accounts, other than cash receipts. Ordinarily reverts or other credits to customer's accounts, other than cash, have the same effect upon a customer's account as the cash payment and can be treated accordingly. Where in extraordinary transactions they do not have the same effect, they can be taken care of through separate journal entries in such a way as to have the equivalent cash effect on the customer's account.

PLAN WISCONSIN ASSOCIATION

Victor Dealers of Eastern Part of State Meet and Take Preliminary Steps Toward the Formation of an Association

FOND DU LAC, Wis., July 1.—At a recent meeting of Victor dealers from the eastern part of the State at the Hotel Appleton here the first steps toward the formation of an association were considered. Further plans for the formation of the organization, which has for its object the general promotion of the Victor business, are under way.

During the meeting here L. C. Parker, of the Badger Music Shop, Victor dealer of this city and Milwaukee, described in an interesting manner the good work accomplished by the Milwaukee Dealers' Association, and H. A. Goldsmith and O. Schopen, representing the Badger Talking Machine Co., of Milwaukee, discussed the success of similar associations throughout the State.

Among those who attended the meeting were: D. M. Groniz, Green Bay; T. R. Bowring, DePere; H. G. Brauer and Otto Look, Kaukauna; Ray Peters, Neenah; Ralph Wilson, Oskosh; James Sandee and W. J. Augustin, this city; Henry Clusen, Manitowoc; Harry Stoffels and E. J. Carroll, of Appleton.

Isn't it funny how many salesmen there are who call other people stubborn for possessing a certain quality which in themselves they call firmness? Tolerance of the other fellow's ideas is worth cultivating.



**BRUNS MADERITE**

## "BRUNS MADERITE"

**DELIVERY COVERS**

You can't go wrong on BRUNS MADERITE Phonograph Delivery Covers for Upright, Console or Period type machines—Our covers are also made for the radio cabinets.



Cover, Straps Attached

**PORTABLE TALKING MACHINE COVERS**

We are making a line of covers for portable cabinets in various shapes and sizes—this type machine really needs a serviceable carrying cover.

**MADERITE DUST COVERS**

Made of durable fleece lined rubberized material—just the thing for the Spring season.

**A. BRUNS & SONS**

50 RALPH AVE.  
BROOKLYN  
N. Y.

**A. BRUNS & SONS**

50 Ralph Ave., Brooklyn, N. Y.

Manufacturers of Everything Made of Canvas



## Four-Minute Conference on Business Topics

### No. 3—Your Losses—Their Prevention

[This is the third of a series of four-minute conferences on topics of direct interest to business men in the talking machine trade which have been prepared for this publication by Lester G. Herbert.—EDITOR.]

Loose collection methods cause much business embarrassment.

Money talks, and the business man who is up to date will bring his affairs to as nearly a cash basis as possible in order to prevent leaks and to insure his own ability to discount his bills. Banks are now using extra precautions in making loans in order to discourage the over-expansion of credit, for only by this means can sound business conditions be fostered.

If you, the business man, are to pay your bills promptly you must be careful to extend credit only to those who are entitled to credit, and you must inaugurate a system which will make courteous but tactful and businesslike insistence on prompt payment.

It is exceedingly important that all invoices and statements be made out and mailed promptly; that the printed terms upon which credit is granted shall appear upon the letterhead; and that delinquents will be followed up with polite firmness in a letter stating that you, as a modern business man, cannot conduct your affairs in a manner to give the best of service and rock-bottom terms without having the cash to reinvest regularly. This will usually bring a response in money or an explanation as to when money may be expected.

The right sort of business men observe their due dates and try to have the cash in their creditors' hands on that date instead of twenty-four or forty-eight hours late. Individuals who pay no attention to their obligations are not entitled to credit concessions.

It is undesirable to offend patrons, but hav-

ing a regular system which is known as a policy of the firm a precedent is soon established which is taken for granted. It is true that an individual may have a good deal of property, but if this is not in the form of cash with which he can pay it does not avail you very much.

Another loss comes through permitting high-priced and skilled men to do work which could be handled as well by less skilled and much cheaper labor.

In one concern the employment of a young fellow of seventeen years of age relieved three trained men so that they did the work previously done by four of them. That is, the young fellow who was paid \$12 a week made it possible to dispense with one who had been paid \$50 a week, thus effecting a saving of \$38 a week, or \$1,976 a year.

Another ease of loss is through the excessive reduction of working hours and laxity about tardiness. Employees respect their work and their employers more when it is managed in an efficient and worthy manner.

### VICTOR PUZZLES FOR THE TRADE

Clever New Picture Puzzles Just Issued for Distribution by Dealers at Fairs, Celebrations, Store Openings and Other Local Events

The Victor Talking Machine Co. has just issued an attractive and interesting picture puzzle for the use of dealers for distribution at fairs, anniversaries, school celebrations, store openings, etc. The puzzles are of the sort that should make a general appeal both to children and grown-ups, and when put together the various sections make up a replica of a Victor record with the faces of many of the noted Victor artists thereon.

Each puzzle comes in a separate envelope upon which there is left sufficient room for the dealer's own imprint and they are offered to the trade at a nominal price considerably below cost. The puzzles were introduced at the Jobbers' convention at Atlantic City recently and were strongly endorsed.

### E. E. HOHMANN COMPLETES TRIP

General Sales Manager of Modernola Co. Returns From mid-West—New Portable Popular

JOHNSTOWN, PA., July 1.—E. E. Hohmann, general manager of sales of the Modernola Co., Inc., of this city, recently returned to headquarters after completing a four weeks' trip throughout the Middle West. Mr. Hohmann visited Chicago, St. Louis, Louisville and other important trade centers. On this trip he not only traveled in the interest of the Modernola, but in the interest of the Modernolette as well. This new portable has already attained considerable popularity throughout the trade and it is expected that it will prove not only an exceptionally big Summer seller, but will enjoy considerable sales throughout the year. Mr. Hohmann stated that he did very good business on the trip and that a number of new agencies were established for the Modernola and its small edition, the Modernolette.

### TALKING MACHINE IN AMBULANCE

Memphis Concern Adopts Innovation for Soothing Ambulance Patients

MEMPHIS, TENN., July 1.—Music while you suffer is the latest refinement in ambulance service in this city. The innovation is found in Collins-Sturla's new ambulance, just put into service, and which is equipped with an excellent talking machine and a large library of records ranging from opera to "blues." While en route in the ambulance the patient is allowed to select his own music and, according to Elmo Cullen, ambulance attendant, the "blues" are the most popular with the sick and injured. The instrument is placed near the pillow of the patient and the tone properly subdued through use of fiber needles.

# PORTABLE PAL PHONOGRAPH

*This  
is a  
portable  
year!*

## "PAL" has met with a national response!

Dealers have been quick to recognize PAL's value!

Many orders have come to us! Many complimentary messages have been sent in. It seems that everybody is expressing genuine favor toward the PAL machine!

People see that PAL is the kind of a portable they have been waiting for—in tone quality—design—price!

They know that PAL gives full \$50 worth of value. They are satisfied—in every way!

That is why they are buying.

And that is why PAL dealers find that PAL brings good business all around.

Order a sample—Today!

### DEALERS' PRICES

WOODEN CASE . \$20  
COWHIDE CASE . \$25

### SPECIFICATIONS

Walnut or Mahogany finish or Cowhide case; 12" wide, 18" long and 8½" high. Weight, about 20 lbs. Equipped with a high-grade motor, playing three 10" records with one winding. Extra fine universal tone arm and soundbox playing all types records. Special sounding board. Equipped with a 10" record album. Heavy nickel plated brass hardware, strong handle for carrying purposes.



# PLAZA MUSIC CO.

18 West 20th Street New York



SUPERIOR STEEL  
**BRILLIANTONE**  
 REGISTERED TRADE MARK  
 NEEDLES

SUPERIOR  
**BRILLIANTONE**  
 REGISTERED TRADE MARK  
 NEEDLES

SUPERIOR  
**BRILLIANTONE**  
 REGISTERED TRADE MARK  
 NEEDLES

SUPERIOR  
**BRILLIANTONE**  
 REGISTERED TRADE MARK  
 NEEDLES

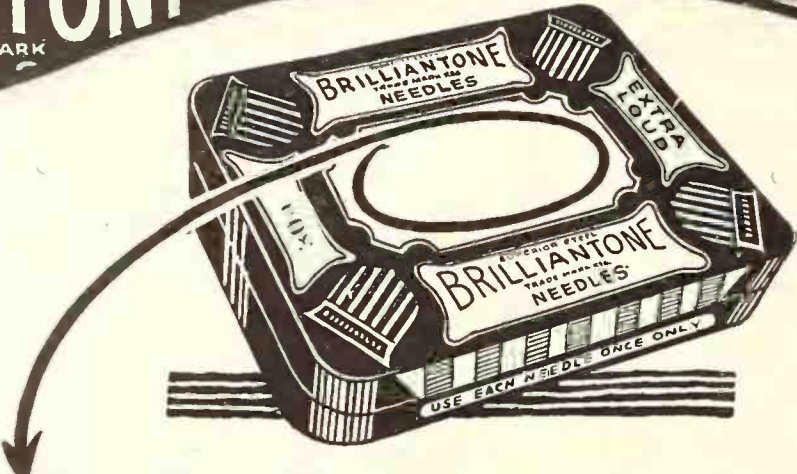

Packed expressly for YOU  
 with your Name

On An Order For  
**175 Tin Boxes**

*Three Tones: Extra Loud, Loud, Medium*

300 needles in each attractively decorated and colored tin box. Think of the value of having your name go into the homes of your customers! Think of the value of having your name seen every time a phonograph is played! Your name on each box of needles will be a constant advertisement for you.

Link Your Name With  
**Brilliantone Needles**

*The largest manufacturers of talking machine needles in America.*

Prices and samples upon request.  
 Tell us to whom you desire shipment billed.

**BRILLIANTONE** STEEL NEEDLE CO.  
 OF AMERICA, Inc.

Selling Agent for W. H. Bagshaw & Co.  
 Factory: Lowell, Mass.

347 FIFTH AVENUE

NEW YORK

SUPERIOR STEEL  
**BRILLIANTONE**  
 REGISTERED TRADE MARK  
 NEEDLES





NO. VII

Dear Bill:

At last the fine, warm Summer days are at hand and, as usual, there are signs everywhere which indicate that many so-called business men have not awakened to the important fact that opportunities for doing business during this season are just as favorable as during the Winter months. Honestly, it gives me a pain the way some dealers accept this as an indisputable fact and make not the slightest effort to find out for their own satisfaction whether people will buy in the Summertime.

Perhaps it is natural to lie down on the job during these enervating days, but no prosperous business can be built up in that way. There are many opportunities for business if the dealers have energy enough to make a stab at getting some of it. Certainly, sitting in the office and telling fish stories will not achieve this highly desirable result.

Knowing you as I do, Bill, old pal, I strongly suspect that you are spending a great deal of your time poring over vacation folders and sitting at your desk dreaming of the fishing and golf which you are shortly to enjoy and, therefore, I am working on the old bromide that "an ounce of prevention is worth a pound of cure" in an effort to make you realize what an opportunity you are letting slide.

You certainly can't afford to sit back in your office chair twiddling your thumbs while a golden opportunity like this slips by during the brief vacation period. Of course, there is a temptation to do this very thing. I have been through the mill myself and I know how it is, but you can wager anything you wish that you are due for an unprofitable rest if you don't roll up your sleeves and go to it.

As to ways and means of getting Summer business, they are varied. The first thing to do is to carefully plan a campaign in which consideration should be given to advertising, circularization, special window displays, personal letters and a Summer service. All of these should be designed especially to carry an out-of-doors appeal. The copy should be of a character which will show the utility of the talking machine as a vacation adjunct, an instrument without which the greatest enjoyment cannot be obtained from any trip. The window displays offer a fine opportunity of impressing the public with the value of the small portable machines for use on trips, etc., and right here I want to stress the fact that when a portable machine is sold during the Summer you have a live prospect for a larger machine when the vacation is over and in either case you have a good prospect for future record sales.

Now, as to special Summer service. The annual migration to and from town can be made the source of profit through increased record sales by making provision to keep these people in touch with the latest records no matter where they are, and it is also a wise and effective stunt to establish a record mail service so that they can be supplied with records without loss of time should they desire any. As your customers return it might prove valuable in building good will if you sent them a list of records which you think they might be interested in, together with a little note stating that you are glad to see that they have returned, expressing the hope that they have had a pleasant time, etc.

Hoping this hits the spot and makes you sit up and take notice, I am,

Your friend,

Jim.

MAGNAVOX SHIPMENT FOR LONDON

Full Carload of Radio Amplifiers Sent by Express From Oakland, Cal., to London to Fill a Special Rush Order—Liked in England

OAKLAND, CAL., July 3.—So great is the demand for American radio equipment that one American firm, the Magnavox Co., of Oakland, Cal., found it necessary to fill an English order by shipping a full carload of amplifiers by express over the six thousand miles between this Pacific Coast city and London.

It is estimated that the shipment will be less than fourteen days on the road and that two weeks after the last box was placed in the express car here the instruments will be on the shelves of London dealers.

Indicating the great increase in radio business



Magnavox Shipments by Express to England are the output figures of this same Oakland factory. One year ago the daily production of radio amplifiers was five; to-day approximately 800 are being produced every day. It is expected this figure will be nearly doubled within the next six months.

The chap who is always bragging about how he told this and that customer where he got off at when the patron came in to make a complaint is not doing himself or the firm any good.

INTRODUCES THE PHONOGAME

Cleverly Conceived Game to Be Used in Conjunction With the Talking Machine—Sales Tests Are Favorable—Campaign Planned

A new concern recently entering the talking machine field is the Phon-O-Game Co., of Elizabeth, N. J., which is manufacturing a specially designed game to be used on the talking machine turntable. This game is in the shape of a round disc with several figures and a dial. The turntable is released and the break applied after a few revolutions and the number opposite the dial when the machine stops designates the number of moves which the player can make on a board nearby. The company has had considerable success in the past few weeks in marketing this new product, and is planning to introduce it to the talking machine trade throughout the country. Sales tests have been made in several stores in New Jersey to try out the sales possibilities of this device, and it was found that this article could be successfully merchandised by the talking machine dealer. In consequence the company is now planning an extensive campaign, and it is expected that within a very short time talking machine dealers throughout the country will carry this device as a part of their regular stock to meet the demands of the buying public.

OSCAR W. RAY TO VISIT COAST

Manager of Wholesale Vocalion Record Department to Call on Trade in Principal Cities in Course of Transcontinental Trip

Oscar W. Ray, general manager of the wholesale Vocalion record department of the Aeolian Co., left New York on July 5 on an extended transcontinental business trip, in the course of which he will visit the Pacific Coast as well as call upon the trade in the principal cities enroute. Mr. Ray expects to be away about a month.



Wall-Kane Needles Protect the Record

WALL-KANE NEEDLES

Used by 80% of the population, sold by the leading jobbers throughout the world.

A nationally advertised article that has been in ever-increasing demand since it was established in 1913

WALL-KANE needles are packed in metal display stands holding 60 packages, 24 loud, 24 extra loud and 12 medium.

They are also packed in cartons of 100 packages of a single tone, either loud, extra loud or medium.

JOBBER ONLY—APPLY FOR SPECIAL PROPOSITION

WALL-KANE NEEDLE MANUFACTURING CO.

Successors to

The Greater New York Novelty Co.

Sole Manufacturers of

WALL-KANE NEEDLES

3922 Fourteenth Avenue

Brooklyn, N. Y.



# The NEW

*Chippendale  
Console  
\$295*

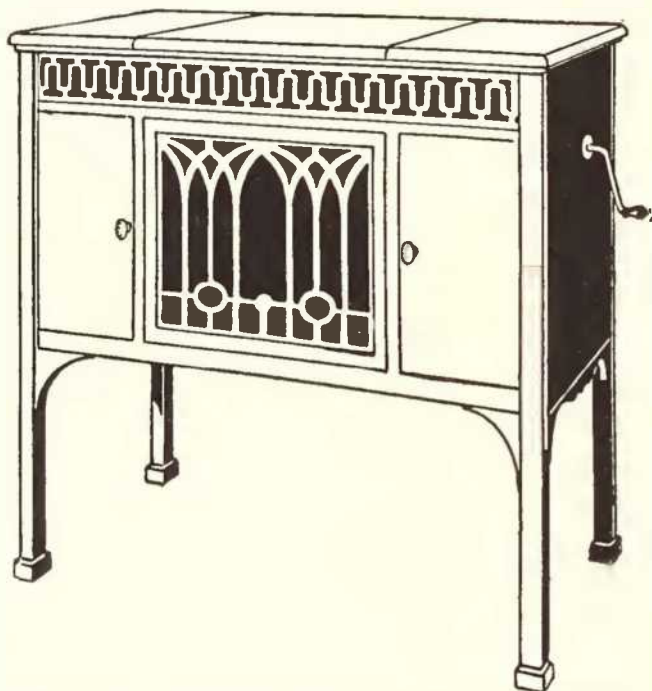

*Italian (Umbrian)  
Design  
\$350*

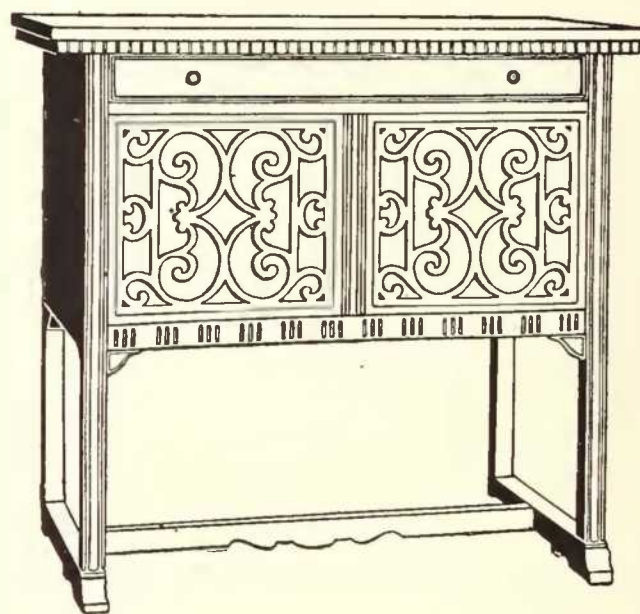

“THE period cabinets which Mr. Edison has adopted for his phonographs are in pleasant contrast to the rather grotesque cases which one so frequently sees. From the characteristically diminutive and graceful Hoppelwhite to the costly replicas of historic pieces, the superior furniture value of Edison cabinets can scarcely fail to impress the lover of good furniture.”

ELSIE DE WOLFE  
*Author of "The House of  
Good Taste" and cele-  
brated designer of house-  
hold interiors.*



# EDISON

THE New Edison Consoles, in period designs, have merited even the approval of those who instinctively look for flaws in every attempt that is made to reproduce the

achievements of the master craftsmen of other days. The New Consoles will bear comparison even with the originals of the various periods that they represent.

*William and Mary  
Design*  
**\$325**



*XVIII Century English  
(Adam) Design*  
**\$375**

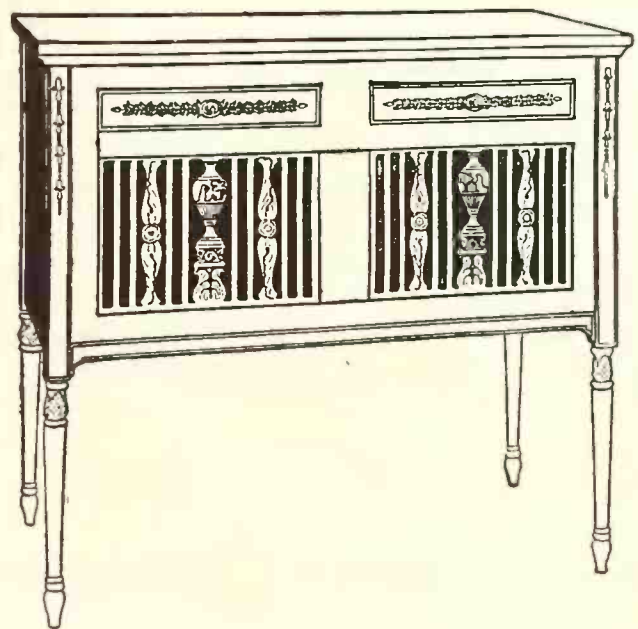

HERE indeed is mechanical perfection enclosed in cabinets that are to Mr. Edison's latest triumph what the faultless case is to the masterpiece of the watchmaker.

Coupled with the high sense of public appreciation that has always been accorded Mr. Edison's achievements, the undeniable charm of these new designs is almost certain to result in an unprecedented demand that every Edison dealer will be called upon to satisfy.

THOMAS A. EDISON, *Inc.*  
ORANGE, NEW JERSEY



## INSECTS AND LUCKY DOGS

By EDWARD FRASER CARSON



Edward Fraser Carson

Out in the Pacific Ocean there are thousands of tiny islands. Verdant and bright with flowers they are veritable garden spots and they are the homes of thousands of people, who, though they may not know it, owe their beautiful island homes to the wonderful work of insects.

Ages ago the coral insects began their work. Their life was but of a few days' duration, and when they died their skeleton remained as the foundation on which succeeding generations of insects built their homes and likewise died. In the building of those islands untold billions of insects had a part. That part did not amount to much—but it counted. It was part of the final structure which finally reared itself above the level of the sea and became an island.

The work of those coral insects holds a great lesson for man, and that lesson is not to despise the little things. It is the little thing that counts, that becomes an integral part of the big thing. It is the trifle that makes perfection—and, added Michelangelo, perfection is no trifle.

But it is in its application to thrift that I mentioned the coral insect. Take the smallest coin we have—the humble copper cent. Save one cent a day and you have \$3.00 a year—counting only business days. In fifty years that is \$150

and at compound interest at 4 per cent it will amount to nearly \$500. Truly did Poor Richard speak when he said, "Take care of the pennies and the pounds will take care of themselves."

The way money grows when once you get the habit of saving regularly is simply astounding. Ten cents a day—60 cents a week—saved for twenty-five years and put in the bank at compound interest will run up to \$1,270 or more. And in fifty years it will amount to nearly \$5,000.

It is so easy to spend money that the ordinary chap is perpetually and everlastingly "broke." But while he is enjoying all the money he makes his careful companion is putting something by for the future.

Take, for instance, yourself. You are twenty years old. You are making, say, \$25 a week. You have none but yourself to support. You can easily save \$10 of it. And \$10 saved each week will make you independent of a job in twenty-five years. In that time you will have \$21,000—and you'll still be a young man, as age is reckoned in these beardless days. Keep it up till you are seventy and you'll have \$80,000 or more.

You, young man who read this—wouldn't you like to know that when you are forty-five years old you would have an income of \$1,000 a year—or at seventy an income of \$3,200—about \$60 a week?

It's all up to you. Barring illness or idleness beyond your power to prevent you can do just that.

Save money. That's as good advice as anyone can give you. Money has been called the root of all evil. That's not so. It's the mania to

get it too fast. Money, in truth, is the root of all blessings—or of many of them.

If you have money in the bank you can hold your head up. You can afford to be independent. Sickness loses many of its terrors.

Every young man who has red blood in his veins dreams that some day he will go into business for himself. He sees some of his friends doing it. He calls them "lucky dogs" and wishes that he, too, might start his own business, be his own boss and eventually boss others.

But the other fellow isn't simply lucky. Nine times out of ten he's a "wise bird" rather than a "lucky dog."

Not a man who can work—and this includes you—but can save something. And the man who saves can "look the whole world in the face, for he owes not any man."

### FORM BUSINESS RESEARCH BUREAU

Providence Chamber of Commerce Co-operates With Brown University in Bureau Formation

PROVIDENCE, R. I., July 3.—What may be the first comprehensive organization established for active co-ordination between business organizations and a university has been devised by the joint action of the board of directors of the Providence Chamber of Commerce and the faculty of the economics department of Brown University, to be known as the Brown Bureau of Business Research. Any individual, firm or corporation residing or doing business in the State of Rhode Island may apply for the service of the Bureau.

### AN ANECDOTE WITH A POINT

A well-known advertising man once answered a man's disbelief in the value of advertising in the following manner: "You can't see the wind, can you?" The man answered, "No." "But you can feel it and see its effects, isn't that right?" "Yes, that's very true," answered the incredulous one. "Well, it is just so with advertising," concluded the ad man.

## YES—THE BEST

De Luxe Needles may cost more but they are made to deliver a Result and not fit a price

Always Insist on Getting

# DE LUXE NEEDLES

and you won't be disappointed.

**DUO-TONE COMPANY, INCORPORATED**

*Sole Manufacturers of De Luxe Needles*

ANSONIA, CONN.



Full Tone

**DON'T FORGET THESE FACTS**

**Perfect Reproduction of Tone No Scratchy Surface Noise**

**PLAYS 100-200 RECORDS**



Medium Tone

**Three for 30 cents (40 cents in Canada)**



## TALKING MACHINE EXHIBITS AT GRAND RAPIDS SHOW

Furniture Exposition Well Attended—What Talking Machine Men Are Showing—Optimistic Feeling Over Business Outlook—Stocks Are Low Throughout Country—Exhibits Reviewed

GRAND RAPIDS, MICH., July 8.—The semi-annual furniture exhibit in this city, which opened on June 15 and closes on July 15, produced a rather unexpected volume of business. Although the number of buyers at the market so far this year has been a record-breaking one, the hotels proved by means of their reservation list that hundreds of buyers will be in before the end of the show. In the furniture as well as the talking machine lines the unexpected rush of buyers with large orders caught manufacturers in many instances unaware and numerous orders have been held up by the failure of new offerings to be ready for display. Quite a number of firms were unexpectedly held up in business by the non-arrival of the samples of their products.

Buying is very liberal this season. Many dealers frankly declare that their stocks are exceptionally low and that they are anxious to have a supply of good merchandise on hand for anticipated Fall business. The number of jobbers and dealers who are placing orders this way is rather surprising. The dopesters around town, at least all who are in the manufacturing end of the game, firmly believe that many dealers are going to be caught with short lines because of this unexpected increase in business. They reason that the building boom, which is general all over the country, is bound to result in great demands for high-grade talking machines and furniture.

One outstanding feature of this Summer show is that all exhibitors made their spaces attractive with carpets, wall hangings and fancy partitions, which showed up their lines to the best advantage. This line of decorations was followed with great care this year by all the exhibitors, who certainly spent more money in decorations than ever before. In most of the exhibition buildings the dolling-up process was carried out to the Queen's taste, displaying the various lines of goods as they might appear in the home of the ultimate purchaser. Some hotelkeepers visiting these spaces were struck with their possibilities and assert that their own places of business would go through the decorating process immediately upon their return home.

The Cheney Talking Machine Co., as usual, had a beautiful display in the showrooms of its building on Munroe street. The entire line of Cheney instruments was on display and attracted favorable comment. Many visiting buyers, even though not in the talking machine game, were drawn to this exhibit. The sales department of the Cheney Co., headed by Professor Forrest Cheney, formed a reception committee for visitors, being augmented from time to time by Cheney distributors who were visiting Grand Rapids.

Up in the Gilbert Exhibition Building the talking machine line which attracted the most attention was that of the Consolidated Talking Machine Co., which held forth in Room 521 under the direction of L. Weguson, local representative. A full line of the products handled by the Consolidated Co. was on display, and much attention was given to the Strand talking machine, which is jobbed by this company.

Another interesting display was that of the Udell Works on the second floor of the Klingman Exhibition Building. This display was in charge of Tom Griffiths, sales and advertising

manager of the Udell Co. Visiting buyers had an excellent opportunity of looking over the entire Udell lines, consisting of talking machine cabinets, piano roll cabinets and portable talking machines. This concern placed attractive invitation cards in the mail boxes at all the hotels. The cards were printed in red and showed portraits of the Udell products. Pasted on top of each card was a small envelope containing a large-sized Baltimore cigar. Immediately under this cigar was printed the invitation to visit the Udell demonstration.

The Player-Tone Talking Machine Co., of Pittsburgh, held its exhibit in the Klingman Building, with I. Goldsmith in charge. This concern exhibited its full line of ten standard models, consisting of cabinets, period and table talking machines. Mr. Goldsmith is an old-time furniture man who for many years prior to his entrance into the talking machine business was engaged in the furniture field. There are very few dealers visiting in Grand Rapids who are not acquainted with him. His line of instruments is in big demand at the show.

H. C. Naill, secretary and sales manager of the George A. Long Cabinet Co., of Hanover, Pa., was in charge of the Long exhibit, also in the Klingman Building. Much interest was centered about this line of three handsome and popular console models, which it has been advertising to the trade for the past two months. In a few weeks the cost of these cabinets will revert to former prices. Mr. Naill stated that the customers had a great opportunity to take advantage of these models and that this was one of the reasons why the Long exhibit was so crowded.

J. G. Griswold and M. A. Guest were on deck, as usual, at the beautiful Widdicomb display held at the Widdicomb factory. For many years the Widdicomb Co. has been a leader in the construction of aristocratic furniture. Dealers who visited this exhibit soon found that the Widdicomb console talking machines in period styles are faithful interpretations of the best designs of the old masters in the art of wood fashioning. The artistry of cabinet designs and finish was shown at its best and the handicraft of this organization, which has for the past three generations enjoyed the reputation of a leader in the design of real furniture, was exploited to the highest degree.

The Bush & Lane factory at Holland, Mich., was also the scene of much activity during the show. Bush & Lane dealers from all over the country, who visited Grand Rapids, hied themselves Hollandward with their friends to make the rounds of this big plant. Walter Lane, president; F. J. Congleton, vice-president; C. L. Beach, secretary, and W. H. Beach, treasurer and general manager, with a large corps of their travelers, were on deck to welcome the visitors, who, after being shown over the plant and its workings, were entertained at the Ottawa Beach Hotel, at Ottawa Beach, a suburb of Holland. The Bush & Lane Co. showed the visitors its new line of beautiful console and period models which is being prepared for the Fall trade. This line is entirely new, every instrument in it having just been designed by President Walter Lane.

(Continued on page 34)



### POPULAR ITALIAN RECORDS LATEST RELEASES

10 Inch Records \$.75 Each

- 1007 Pulcinella Ad Una Festa Da Ballo. Scena Comica. Un Balbuziente in Tribunale. Scena Comica.
- 0991x L'Altalena. Song....Cav. G. Godono  
E L'Ammore. Song....Cav. G. Godono
- 1000 'O Guarracino. Part 1. Song, P. Mazzone  
'O Guarracino. Part 2. Song, P. Mazzone
- 0957x Luntano 'A Te, Mari'. Song, Cav. G. Godono  
L'Acquaiola. Song....Cav. D. Giannini
- 0997x Serenatona. Song....R. Ciaramella  
Vipera. Song....Jole Baroui
- 0955x Tie-Ti-Tie-Ta. Song....R. Ciaramella  
Piererotta. Song....R. Ciaramella
- 0993x Venerdi'. Song....F. Rondinella  
'E Ssignurine D' 'O Palazzo. Song, R. Ciaramella
- 0989x Mia Dolce Amica...Cav. Uff. G. Godono  
Voce D'Amor....Cav. Uff. G. Godono
- 0995x Totonno 'E Quagliarella....Ciaramella  
Niru Te .....Langella
- 1001x Signora Mia (Duetto),  
Donnarumma-Ciaramella  
'A Cura 'E Mamma' (Duetto),  
Donnarumma-Ciaramella
- 1003x Canzone Americana .....Donnarumma  
Donna Fifi' .....Ciaramella
- 1005x Mo Esce Achille. Scena Comica.  
Il Cavamaechie. Scena Comica.
- 1019x Momenti Gioiosi. Orchestra.  
Al Bosforo. Polka.
- 1021x Carmen (Selection). Bells.  
Nozze D'Oro. March.
- 1033x Abat—Jour (Salomè),  
Ciaramella-Rondinella  
Ninnolo....Cav. Uff. G. Godono, Tenore

We Are Also Manufacturers & Distributors of  
Italian Popular Music Rolls

New Hits Released the 15th of Each Month

### JUST OUT

- 190—Donna. Versi e Musica di A. Giuliani. (Word Roll) .....\$1.25
- 230—Tarantella A Cunailante. Versi di L. Sica. Musica di R. De Luca (Word Roll) ..... 1.25
- 202—Dichiaramento. Versi di A. Scala. Musica di F. Buongiorno. (Word Roll) ..... 1.25
- 213—Fior Di Campo. Waltz. by D. Ietti. .90
- 057—L'Incantevole. Mazurka. by J. Gioè .90
- 218—Coscienza. Versi di S. Baratta. Musica di R. Falvo. (Word Roll)... 1.25
- 203—L'Epoca. Marcia Sinfonica di C. Papa 1.00
- x201—Te Chiamme Maria. Versi di L. Bovio. Musica di G. Lama. (Word Roll) .....\$1.25
- x180—Acqua Mmoeca. Versi di R. Chiu-razzi. Musica di R. Falvo. (Word Roll) ..... 1.25
- 051—Napule. Addio! Versi di R. Cacace. Musica di D. Ietti. (Word Roll) 1.25

### ITALIAN BOOK CO.

Music Dep't

145-47 Mulberry St.  
New York City

DISCOUNT TO DEALERS—ASK FOR CATALOGUES



## PHONOGRAPH CASES RADIO CASES

Reinforced 3-ply Veneer

The Standard Case for Talking  
Machines and Radio Sets

Let us figure on your requirements

MADE BY

PLYWOOD CORPORATION, Goldsboro, N. C.

Mills in Va., N. C. and S. C.





For straight slap-stick song-and-dance comedy "Skeeter and The June Bug," by Harry C. Browne, gets the horse hair handkerchief. This hick act is backed up by a coon classic, "Dars a Lock on de Chicken Coop Door." A-3622.

Columbia Graphophone Co.  
NEW YORK

### EXHIBITORS AT GRAND RAPIDS SHOW (Continued from page 33)

True to Bush & Lane fashion, these instruments are made throughout in beautiful piano finish.

Across the street from the Pantlind Hotel, in Grand Rapids, are located the big showrooms of the Aeolian Co., wherein was displayed the Aeolian Co.'s line of graceful new Queen Anne period models. All these instruments were equipped with the famous "Graduola" tone control, which makes the Vocalion a musical instrument par excellence. Besides the line of talking machines a complete library of Vocalion Red records was shown.

Visitors to the plant of the Grand Rapids Brass Co., on Scribner avenue, were shown around by J. L. Murray, vice-president, who explained in detail the manufacture of brass hardware for talking machines. This company manufactures automatic stops, cover supports and cabinet hardware of all descriptions and designs. The visitors received a liberal education in the manufacture of these parts and soon discovered that it is no simple matter to turn them out. Many of them took advantage of this little schooling from an educational standpoint and admitted that heretofore they had confined their sales arguments to cabinet manufacture and tone production, with very little attention to the hardware. Now, however, a great many of them intend giving the prospect some insight into the production of hardware.

J. Kersten, president and general manager of

the Kersten Composition Products Co., Inc., of Grand Rapids, brought out the fine points of his amplifiers before the visitors to his plant. The company manufactures the well-known Kersten composition talking machine horn and makes a specialty of building horns to order. Quite a number of very high-grade talking machines of repute now on the market use this company's product exclusively and Mr. Kersten pointed out the reason for their doing so to his listeners. Not only were composition horns shown to the visitors, but all products of this company were shown as well. These embraced manikins, dress models and so forth for the use of window decorating. The decorations are used in turn by all commercial houses in windows for displaying clothing, household things and so forth.

The Ionia street plant of the American Phonograph Co. was also very active during the show season. E. L. Meeuwesen was kept busy entertaining out-of-town buyers who were interested in talking machines. The new model put out by this concern attracted considerable attention.

One of the interesting novelties in talking machines to be shown during the show was the "Davenola," manufactured by Andy Mouw, Inc., in the Gilbert Building. The "Davenola" is an interesting combination of the davenport and talking machine. The davenport is of a regulation overstuffed style, with the arms on either side constructed so as to tip back to reveal the instrument. The talking machine itself is concealed in one arm and the other is given over to a record-filing case, which will hold fifty or more

records of either ten or twelve-inch size. The talking machine part may be had with either a spring or electric motor. The amplifier is of standard size and swings down toward the bottom of the arm.

### NEW VOCALION DISTRIBUTOR

Woodside Vocalion Co. Has Very Attractive Quarters in Portland, Maine

The latest addition to the growing list of Vocalion and Vocalion record distributors is the Woodside Vocalion Co., 134 High street, Port-



Woodside Vocalion Co. Warerooms

land, Me., which has for its territory the entire State of Maine and has already established a number of very promising dealers for both phonographs and Red Records. The company has very attractive and commodious quarters for the display of the Vocalion line, as is indicated by the illustration herewith, and has on hand a complete stock to provide for the prompt filling of orders.

### RADIO AS A CURE FOR CANCER

Chicago Physician Reports Successful Experiments With Some Forms of Disease

CHICAGO, ILL., July 8.—Radio is now taking its place in the scientific treatment of human ailments, according to Dr. T. Howard Plank, of this city, who says that some forms of cancer, considered incurable for years, can be cured through this agency, and naming two persons who were so healed.

In describing the method in which the radio is used as an aid to a cure before the National Society of Physical Therapeutics at the national convention of the American Institute of Homeopathy Dr. Plank said: "The electric scalpel is run by radio. The machine uses the same current that is used in sending radio messages. There is no actual contact between the diseased tissues and the knife, because as soon as the instrument approaches the infected part the tissues wither up and disappear. In four or five days the patient is out of bed and in ten days he is on the street again."

Criticism is a bad thing unless it is constructive.

## VELVET COVERED TURNTABLES

ADD TO THE QUALITY OF MACHINES



A.W.B.

Boulevard  
VELVETS

THE BEST TALKING MACHINES ARE EQUIPPED WITH

## A. W. B. BOULEVARD VELVETS

GRAND PRIZE—GOLD MEDAL, ST. LOUIS EXHIBITION

WRITE FOR SAMPLES AND PRICES

A. WIMPFHEIMER & BRO., Inc.  
450-460 Fourth Avenue, New York

ESTABLISHED 1845





RICHARD STRAUSS  
Dean of European Composers



ELLY NEY  
International Pianist



FLORENCE EASTON  
Prima Donna Soprano  
Metropolitan Opera Company

# BRUNSWICK

(Double-faced)

## Gold Label Records

Win Nation-Wide Popularity  
with Dealers and Public

The record-buying public is fast learning two things of vast importance to Brunswick dealers:

First; that Brunswick Artists are supreme in their fields and that whenever they desire the world's best music rendered with the greatest beauty and fidelity, the Brunswick is the record to buy.

Second; that in purchasing a Brunswick Gold Label (double-faced) Record they are getting something that will forever prove a valuable possession in the home, a living inspiration at all times.

Strauss, Chamlee, Easton, Rosen, Dux, Godowsky, Danise, Pavloska, are only a few of the internationally famous Brunswick artists who are now recording on double-faced records—giving record buyers twice the value for just a little more.

THE BRUNSWICK-BALKE-COLLENDER CO.

Manufacturers—Established 1845  
CHICAGO—NEW YORK—CINCINNATI  
New England Distributors: Kraft, Bates & Spencer, Inc.  
1265 Boylston Street, Boston, Mass.  
Canadian Distributors: Musical Merchandise Sales Co.  
79 Wellington Street West, Toronto, Ont.

# Brunswick

PHONOGRAPHS AND RECORDS

Other noted Operatic and Concert artists of the day recording exclusively for Brunswick are:

Richard Bonelli	Theo Karle	Marie Tiffany
Elias Breeskin	Elizabeth Lennox	Irene Williams
Max Rosen	Virginia Rea	Willem Willeke



BRONISLAW HUBERMAN  
Sensational Violinist of the Day



IRENE PAVLOSKA  
Soprano  
Chicago Opera Association



GIUSEPPE DANISE  
Premier Baritone  
Metropolitan Opera Company



CLAIRE DUX  
Soprano  
Chicago Opera Association



LEOPOLD GODOWSKY  
Master Pianist



MARIO CHAMLEE  
Tenor  
Metropolitan Opera Company







# DISCOVERED!

A Brand New Method of Learning

## The Radio Code Quickly—

Mr. J. C. H. Macbeth, author of this new method, was able to train thousands and thousands of men in the British Signal Forces, in one-tenth the usual time required to learn the Radio Code. This phenomenal short cut to code study and a code practice record has been recorded exclusively

on

# Okeh Records

The Records of Quality

By JACK BINNS, the famous wireless man and Radio Editor of the New York Tribune.

The American Code Company has published this system in book form, to retail for 50c per copy. The records mention the book and the book advertises these Records. Okeh Dealers can sell both records and books.

Hundreds of thousands of Radio Fans are eagerly looking for a quick and easy way to learn the Radio Code. Okeh dealers will have this field to themselves! Write to the nearest Okeh Distributor today for full details on this proposition. The records will soon be released.

### COMPLETE LIST OF OKEH DISTRIBUTORS

CALIFORNIA—San Francisco,  
KOHLER & CHASE, 26 O'Farrell St.

COLORADO—Denver,  
MOORE-BIRD Co., 1751 California St.

GEORGIA—Atlanta,  
J. K. POLK FURNITURE Co.,  
294 Decatur St.

ILLINOIS—Chicago,  
CONSOLIDATED TALKING MACHINE Co.,  
227 W. Washington St.

W. W. KIMBALL COMPANY,  
Wabash Ave. & Jackson Blvd.

INDIANA—Indianapolis,  
KIEFER-STEWART Co.,  
Capitol Ave. & Georgia St.

LOUISIANA—New Orleans,  
JUNIUS HART PIANO HOUSE,  
703 Canal St.

MARYLAND—Baltimore,  
A. J. HEATH & Co.,  
321 Park Avenue.

MASSACHUSETTS—Boston,  
THE BAY STATE MUSIC CORP.,  
142 Berkeley St.

MICHIGAN—Detroit,  
CONSOLIDATED TALKING MACHINE Co.,  
2957 Gratiot Ave.

MINNESOTA—Minneapolis,  
DOERR-ANDREWS & DOERR

MISSOURI—St. Louis,  
THE ARTOPHONE CORP., 1103 Olive St.

NEBRASKA—Omaha,  
LEE-COIT-ANDRESEN HARDWARE Co.,

NEW YORK—Buffalo,  
IROQUOIS SALES CORP., 210 Franklin St.

New York City,  
BRISTOL & BARBER Co., INC.,  
3 East 14th St.

NEW YORK DISTRIBUTING DIV.,  
15 W. 18th St.

NORTH CAROLINA—Goldsboro,  
INDEPENDENT JOBBING Co.,

OHIO—Celina,  
HARPONOLA COMPANY

Cleveland,  
THE RECORD SALES COMPANY,  
1965 E. 66th St.

Cincinnati,  
STERLING ROLL & RECORD Co.,  
137 W. Fourth St.

PENNSYLVANIA—Philadelphia,

A. J. HEATH & Co.,  
27-29 So. Seventh St.

SONORA COMPANY OF PHILADELPHIA,  
1214 Arch St.

Pittsburgh,  
THE RECORD SALES COMPANY,  
806 Penn Ave.

Williamsport,  
RISHELL PHONOGRAPH Co.

TEXAS—Dallas,  
SONORA DISTRIBUTING Co. OF DALLAS  
Houston.

HOUSTON DRUG COMPANY.

WISCONSIN—Milwaukee,  
YAHR & LANGE DRUG Co.,  
207 E. Water St.



## General Phonograph Corporation

OTTO HEINEMAN, PRESIDENT



25 West 45th Street, New York City







**GOLF TOURNAMENT OF JOBBERS**

Interesting Annual Contest Followed Jobbers' Convention—C. Alfred Wagner Proves Champion for Year, With Low Gross Score of 87—C. A. Grinnell Wins The World Cup

Immediately following the annual convention of the National Association of Talking Machine Jobbers at the Hotel Ambassador, Atlantic City, N. J., the golfers of the Association adjourned to the Seaview Golf Club, at Absecon, for the purpose of participating in the annual golf tournament of the Association, which proved a distinctly interesting contest.

C. Alfred Wagner, of the Musical Instrument Sales Co., proved the tournament champion by



C. Alfred Wagner Is Champion

winning the prize for the low gross score, this being the R. S. Steinert trophy, with a score of 87.

C. A. Grinnell, of Grinnell Bros., Detroit, captured The Talking Machine World trophy with the second low gross score of 89, while French Nestor, who made such a good showing in last year's tournament, captured the Walter Staats ringer trophy with a low net score of 77.

All the other prizes, and they were numerous, were awarded for net scores. L. W. Collings captured the Eldridge R. Johnson trophy, with a low net of 79; C. G. Campbell, the J. N. Blackman trophy with 84; J. S. MacDonald, the A. A. Grinnell trophy with 84; R. S. Steinert, the George A. Dodge trophy with 85; A. A. Grinnell, the J. C. Roush trophy with 86; G. T. Williams, the Louis Buehn trophy with 87; W. H. Russell, the George E. Mickel trophy with 87; Norman Cur-

tice, the L. W. Collings trophy with 88; Lloyd L. Spencer, the Knickerbocker Co. trophy with 89; A. A. Trostler, the T. H. Towell trophy with 89; W. F. Davisson, the A. A. Trostler prize with 90; F. P. Oliver, G. P. Ellis, E. J. Dingley and A. D. Geissler, with low net scores of 91, each were awarded a dozen golf balls presented by the Schmelzer Co.

**WILL DO GENERAL RECORDING**

Bell Recording Corp. Announces Plans—C. R. Johnstone General Manager—Associated With National Metals Depositing Corp.

The Bell Recording Corp. was recently incorporated under the laws of the State of New York, for the purpose of making records for individuals and the trade in general. The recording is under the personal supervision of C. R. Johnstone, who has been identified with the recording industry for thirty years and who was formerly associated with the Aeolian Co.

The Bell Recording Corp., whose offices are located at 9 East Forty-seventh street, New York, is associated with the National Metals Depositing Corp., Mt. Vernon, N. Y., which for the past year has been an active figure in the production of masters, mothers and stampers. The executive personnel of the two companies is similar, Louis G. Young being president of both companies, with Milton G. Lumsden secretary and treasurer of the two concerns.

**MUSIC HELPS GOLF STROKE**

President of California Golf Association Demonstrates Value of Music in Golf

LAKE PLACID, N. Y., June 26.—Rhythm enters in a large degree into successful golf playing and one may accomplish much toward mastery of the game through practicing strokes to talking machine music, Everett H. Seaver, president of the California State Golf Association, and former amateur champion of the Western States, told 450 delegates of a Cleveland firm in convention here. Mr. Seaver demonstrated his contention by driving imaginary golf balls from an improvised tee on a hotel rug, at the same time indicating how his movements corresponded with the tempo of waltz music played by a pianist.

**MOVES TO NEW QUARTERS**

The American Phonograph Exchange, jobber of phonographs, records and accessories, moved recently from 339 Central avenue to 366 Wilson avenue, Brooklyn, N. Y., where the company has increased facilities for supplying dealers.

**NYOIL**  
FOR YOUR PHONOGRAPH

IN THE HANDY CAN



**Made in Our Watch Oil DEPARTMENT**

which for half a century has made 80% of all the watch, clock and chronometer oil used in America.

**The Best Oil For Any Talking Machine**

In refining, Nyoil is given the same care as our famous watch oil receives. All gums and impurities are removed, leaving it

**Colorless, Odorless and Stainless.**

Housekeepers say they would not be without Nyoil because it is best for phonographs and sewing machines—for polishing furniture and woodwork and is odorless and will not stain. It is free from acid and will not gum, or become rancid. Sportsmen find it best for guns because it prevents rust.

NYOIL is put up in 1-oz., 3-oz. and 8-oz. Bottles and in Quart and Gallon Cans.  
For Sale by all Talking Machine Supplies Dealers  
**WILLIAM F. NYE, New Bedford, Mass., U.S.A.**

**M. PHILIPS IN NEW LOCATION**

Grafonola Shop Now in Heart of Business District—Van Veen Installation

WASHINGTON, D. C., July 6.—The Grafonola shop of M. Philips has been moved into attractive new quarters at 1128 Seventh street, N. W., the heart



M. Philips Grafonola Shop

of the business section of this city. Before moving into the new location the entire store was remodeled and tastefully decorated. The forward portion of the store is taken up with the service counters, accessory display cases and a large record rack. On both sides of the rear of the establishment are located sound-proof record demonstration booths, and the center of the floor contains the display of Grafonola models. The fixtures were installed by Van Veen Co., Inc.

**MUTUAL**  
**tone ARMS & SOUND BOXES**

There are three things that go to make up satisfaction:

1. QUALITY
2. SERVICE
3. PRICE

And we can satisfy you in each particular. A test will convince you that Mutual Tone Arms and Sound Boxes are the Best on the market. We give prompt and efficient service. Prices from \$2.15 up.



No. 3 TONE ARM  
No. 5 REPRODUCER

**Mutual Phono Parts Manufacturing Corp., 149-151 Lafayette Street New York City**

The Russell Gear & Machine Co., Ltd., 1209 King St., West, TORONTO, CAN., Exclusive Distributors for Canada and All Other British Possessions



# SIMPLEX

## Electric Phonograph Motors

*The SIMPLEX Electric Phonograph Motor Represents a New Phase in the Development of Sound Reproducing Instruments.*

**NOISELESS**

**ELIMINATES WINDING**

**TROUBLEPROOF**

Make This Your  
**LEADING**  
Line for the  
Coming Season

Sample  
Price **\$19.50**



**GUARANTEE**  
The SIMPLEX Electric Phonograph Motor is guaranteed Trouble-proof throughout and any parts or part thereof that should prove defective at any time, we will repair or replace same by a new motor, free of charge.

Particulars,  
Quantity Prices, etc.,  
on Application.

TRADE

MARK

The Mission of the SIMPLEX Electric Phonograph Motor is to reproduce music just as it was originally rendered. For its perfect and faithful reproductions of all disc records the SIMPLEX Electric Phonograph Motor will play any record you wish to hear and play it as it should be played.

It has an absolute constant speed under variations of voltages and frequency and records may be set at any speed desired—and it is built absolutely without a governor.

**BETTER BUILT**

**BETTER DESIGNED**

The SIMPLEX Electric Phonograph Motor has no competition because it is the only electric phonograph motor of its kind in the world. There are many features by which one can determine the efficiency of the SIMPLEX Electric Phonograph Motor. The essential features are:

- |                |                |            |              |
|----------------|----------------|------------|--------------|
| No Gears       | No Commutator  | No Springs | No Oiling    |
| No Governor    | No Brushes     | No Winding | Noiseless    |
| No Adjustments | No Transformer | No Belts   | Troubleproof |

**Record Stops Automatically on Last Note**

It represents the very best of inventions and improvements and we therefore confidently say that the SIMPLEX Electric Phonograph Motor is combined with the highest precision of workmanship and select material.

**TEST A SIMPLEX ELECTRIC MOTOR ON OUR 30-DAY TRIAL OFFER**

When a Simplex Electric Motor is sent out, it is not sold until the motor has demonstrated in your own shop, in your own cabinet, during a 30-day test, that it will do all we claim. An extremely fair proposition in which the Simplex Motor is judged by its performance in your cabinet under your inspection. No strings to this offer. Your decision is final.

*Manufactured in United States and Canada by the*

**Simplex Electric Phonograph Motor Co.**

104 NEW WILDER BUILDING, 321 BLEURY ST., MONTREAL, CAN.



**PHONOGRAPHIC EPIGRAMMATICS**

By  
HAYWARD CLEVELAND

Mourn not the "Nothing down—Nothing a month" competitive sale you have lost. That is the other fellow's funeral now and it may be his funeral in more senses than one before he has done with that sort of business.

When writing a letter soliciting business do not turn the page. Let the other party see the end from the beginning. He will then take time to read.

Dr. Alexander McL. Hamilton, the great alienist and grandson of Alexander Hamilton, once said: "We are none of us at all times sane." Should not this make us more charitable toward the eccentricities of others?

The window—let it not be said that "Now we see through a glass darkly," but display "With such a luster he that runs may read." Observe, appreciate and enter.

When despondent ask yourself this question: Would I exchange places with another without knowledge of his past and a look into his future? Then cheer up!

**CIRCULAR BOOSTS PORTABLE SALES**

G. W. Haltom, Fort Worth Victor Dealer, Boosts Record Business by Monthly Letters Calling Attention to Special Records

FORT WORTH, TEX., July 6.—G. W. Haltom, jewelry and talking machine dealer at Seventh and Houston streets, is taking advantage of the vacation season to boost the sale of portable Victrola models in a result-getting manner. The plan consists of an attractively prepared circular with illustrations of the various types of portable models. The text is in tune with the vacation spirit. The circular has brought good returns.

Each month also a circular letter is sent to customers calling attention to four or five special records. These letters are sent out just before the new record releases are received and have resulted in a considerable stimulation of business during the period of each month when record buying is inclined to lag.

**RECORD MUSIC CURES STAMMERING**

Well-known Professor Cures Impediments in Speech With Aid of Special Records

Talking machine record music has been used for many strange purposes, not the least of which is its aid in the curing of diseases and as an aid to physicians. One of the latest uses to which record music has been put, however, is as a cure for stammering.

Professor O. H. Ennis, who has gained national fame for his work in the curing of this form of disease, is responsible for this latest use of the talking machine and the music which it reproduces. He has recorded three double-disc records which contain a complete course of instruction for the correction of stammering. A number of children and adults who have been handicapped through stuttering have already been cured.

**TALKING MACHINE SHOP OPENS**

HAGERSTOWN, Md., July 5—The Talking Machine Shop, an exclusive Victor establishment, was recently opened in the Young-Stickell Building, South Potomac street, this city. The Victor line is displayed to advantage in the spacious and attractive quarters, which have been entirely remodeled to meet the demands of the business.

**THE WIDE APPEAL BUILDS BUSINESS**

An Enterprise Can Grow Only in Proportion to the Growth of the Number of Customers and These Can Be Materially Increased by Reaching a Greater Number of People

In every mercantile enterprise growth depends entirely upon the number of customers who patronize the establishment. This is one of the fundamental principles of business building. Naturally, then, the rapidity with which the business grows depends upon the speed with which the customers are secured and the success of the efforts of the dealer in holding them once they are secured.

There are many ways in which customers can be induced to enter the store, one of the most important of which is through the advertising, and right here is where many dealers make a serious error. They make up their minds that they want to cater to some one particular class of people and all advertising is prepared with this particular object in view.

The population of the average city or town consists of the wealthy people, middle class and poor. Included in the wealthy and middle classes are people of various nationalities, and this fact offers the talking machine dealer a further opportunity of enlarging his clientele by well-directed advertising pushing his foreign records. The first two classes of people mentioned are the ones which the dealer should cater to if he is to attain a maximum degree of success. The very poor people offer little opportunity for profitable selling and at any rate the time spent in this

direction could be put to better and more profitable use by devoting it to sales promotion work with the others. A sales campaign planned with these facts in mind which has for its basis intensive selling is bound to produce results.

**VOCALION RECORD CUT-OUT PLAN**

Aeolian Co. Announces Cut-out Plan Effective on July 1 and Applying to Popular Records—Will Affect Over 10 Per Cent of Catalog

In effect on July 1, and continuing until August 15, the Aeolian Co. has announced a special cut-out plan for Vocalion Red records which will affect over 10 per cent of the popular records in the catalog and which is expected to reduce materially the stock in the hands of distributors. The cut-out exchange applies to the 14,000 series and the plan provides that distributors shall purchase two new records of the same series as the records returned in the cut-out list or that they shall have the option of purchasing three records from any series other than the 14,000 for two records returned in the cut-out list.

Only records that are in perfect and salable condition can be returned. All records are returned at the distributor's risk, with transportation charges prepaid, and no records will be received under the cut-out arrangement after August 15.

It is believed that the cut-out arrangement will prove of distinct advantage to the distributors by enabling them to get their stocks of live records in first-class shape before the coming of the Fall season.

**Cash in on the Wireless Demand**

Our specially equipped Cabinets, with horn and all apparatus out of the way, sell themselves. Also in stock as complete Phonographs or Cabinets for assemblers. Write for Prices



**Seaburg Mfg. Co.**  
Jamestown, N. Y.

No. 250T, List Price \$195.00  
Usual discounts to dealers  
48"x28"x31" high. Finished all around  
Genuine Mahogany, Walnut or Oak

The Biggest Value on the Market. A Trial Order Will Convince





Never such **REALISTIC**  
Volume of Sound from  
a Phonograph before!

To play a band or dance record for a customer with a volume of sound equal to that made by the original musicians, and yet retain with that volume all the sweetness and harmony of Sousa's leadership—that is what the MAGNAVOX TELE-PHONOGRAPH is doing for phonograph dealers—doing it for more of them every day.

Selling records (while important) is just a beginning of what it will do for you and your store.

It is bringing new business to hundreds of dealers.

The Magnavox Tele-Phonograph is a simple attachment

to the phonograph. It is a genuine business-builder and money-earner.

Every phonograph owner is a prospect for

The MAGNAVOX TELE-PHONOGRAPH —and we help you sell them.

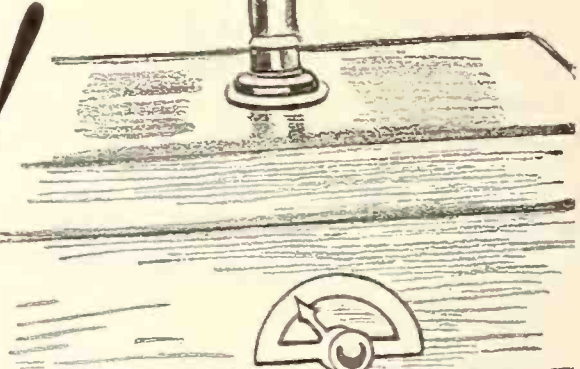

*On the veranda of a summer hotel—full strength dance music—as much like band or orchestra as the real thing*

Write our nearest office for full information about this truly wonderful instrument.

THE MAGNAVOX COMPANY  
General Offices and Factory  
2701 East 14th Street, Oakland, Cal.  
New York Office:  
370 Seventh Avenue  
Penn. Terminal Building

**MAGNAVOX**  
*Tele-phonograph*



The roads in all directions are alive with motorists. Columbia road signs, imprinted with your name, along your highways will catch them coming and going. See the Columbia Dealer Service Man about a supply of these signs.

Columbia Graphophone Co.  
NEW YORK



**GRANBY CORP. IN NEW YORK CITY**

Takes Possession of Central Quarters at 37 West Twentieth Street, With O. P. Graffen in Charge

The Granby Phonograph Corp., of Norfolk, Va., has taken possession of its new headquarters for the New York sales offices of the company. The suite of offices located on the ninth floor of the building at 37 West Twentieth street provides excellent display rooms as well as business quarters. One room will also be devoted to



O. P. Graffen

storage purposes. These offices will be conducted in addition to the warehouse on Sixteenth street. It is expected that these greatly increased facilities will provide remarkably increased service for Granby dealers in the metropolitan district.

O. P. Graffen, well known throughout the talking machine industry, is in full charge of the offices as New York sales manager. His training well qualifies him for his important duties in this respect. He has been closely connected with the talking machine industry for almost seventeen years, two of which were spent with the Victor Talking Machine Co. and fourteen years with the Columbia Graphophone Co. Mr. Graffen is not only a thoroughly experienced talking machine man, but numbers many friends throughout the trade.

**PREPARED FOR LARGE FALL TRADE**

WINSTON-SALEM, N. C., July 1.—Mrs. Gloraine Hastings Miller, manager of the Victor department of the Watkin's Book Store, of this city, recently returned from a two months' trip to the Pacific Coast. Mrs. Miller had a very enjoyable trip and visited all points of interest. Referring to future business conditions she states that she is preparing for a very large Fall business and is entirely optimistic over the outlook for the balance of the year.

The Harklin Store, of Goshen, Ind., is planning to open a talking machine department.

**MECCA BAND ON OKEH RECORDS**

Four Mecca Shrine Numbers Now in Hands of Okeh Dealers — Interesting and Popular Marches Well Played by Mecca Band

The Mecca Band of the Mecca Temple of New York has recorded four of its six most popular numbers on two Okeh records, and these records are now in the hands of Okeh dealers throughout the country. One of these records, No. 4536, carries on one side the Mecca song written by Mack Stark and on the reverse side the popular march, "Turque," so long identified with Shrine ceremonial work. The other record, No. 4583, features on one side the march, "Tartare," now used by Mecca Temple for processional work, and on the other side, "Cyrus the Great," also used during the ceremonials.

These Okeh records were made by the Mecca Temple Band, under the direction of Arthur H. Hoffman, conductor, and a royalty is paid to the band for the records, the proceeds of which will be invested in bonds for the new Mosque.

**GOES AFTER VICTOR PUBLICITY**

HERRIN, ILL., July 5.—Fay Luyster, manager of the Victrola department of the Cline-Vick Stores, which operate a number of branches in this State, took advantage of a Country Club dance recently to demonstrate some of the latest Victor records to the dancers. The demonstration was received with enthusiasm and much good publicity resulted.

**OPENING OF ALEXANDER'S SHOP**

Handsomely Equipped Establishment in Long Branch Is Well Laid Out—Opening Well Attended—Floral Pieces Sent by Jobbers

LONG BRANCH, N. J., June 27.—Alexander's Music Shop, Victor retailer, had its formal opening here on Saturday, June 24. The new showroom, located in the Imperial Hotel Building, is attractively and efficiently laid out and is said to be one of the show places of the city. Eight demonstration booths have been installed and another showroom is devoted to pianos and other musical instruments, as Mr. Alexander is also the local agent for J. & C. Fischer pianos. The opening was well attended; flowers were sent by C. Bruno & Son, Inc., New York City; the Knickerbocker Talking Machine Co., of New York; and Collings & Co., of Newark. Other attractive pieces were also sent by personal and business friends of Mr. Alexander outside of the trade.

A. Murray, of the sales staff of C. Bruno & Son, Inc., Victor distributors, spent the evening assisting Mr. Alexander, who stated that on the opening night he made over 250 sales. An appreciation of Mr. Murray's co-operation was to be found in an advertisement of the company appearing in the local papers the following week, in which this paragraph appeared: "We also wish to thank Mr. Murray, of New York, representing Bruno & Son, Victor distributors, who so kindly assisted us."

**Superior Tone Quality**

**Bell Hood Needle**

does it

**Most natural tone reproductions**

Try your favorite record with a Bell Hood Needle

**BELL HOOD NEEDLE COMPANY**  
183 Church Street, New Haven, Conn., U. S. A.



**JOHN V. DUGAN HONORED**

Well-known New Orleans Dealer Now President of Southern Victor Dealers' Association—Well Qualified for This Very Important Post

At the recent convention of the Southern Victor Dealers' Association, held in Mobile, Ala., John V. Dugan, of the Dugan Piano Co., New Orleans, La., was elected president. Mr. Dugan's election was a matter of keen pleasure to every member of the Association, as for the past four



John V. Dugan

years he has been an active factor in all of the Association activities.

As a progressive Victor retailer Mr. Dugan has left nothing undone to make his establishment in New Orleans one of the most attractive Victor stores in that city. His thorough knowledge of every phase of retail selling has enabled him to give splendid service to his clientele and he is planning to give the same kind of service to the Southern Victor Dealers' Association during the coming year.

**STUDENTS MAKE GOOD CANVASSERS**

A certain talking machine dealer has secured a number of live prospects and closed several machine and record sales as a result of hiring high school boys and girls as canvassers.

**GERMAN PHONOGRAPHS AT ADEN**

Germans Making Inroads Into Market That Is Neglected by American Manufacturers, According to Report by United States Consul

German machines have for the first time recently appeared on sale at Aden, says Consul Cross in a report to the Department of Commerce. These machines are small but attractively painted, a feature which appeals strongly to the native purchaser. They are of the hornless type, which also is an attraction, because the careless use to which the horns were subjected in many cases speedily ruined the sound box on the old machines. Other minor features such as the detachable character of the sound box when not in use also are arousing favorable comment.

The most attractive aspect of the new machines, however, is the price. The Austrian machines were sold at Rs. 65 each. The German instruments can be purchased for Rs. 23, including six small records, put up in an attractive album. The records are only four inches in diameter. The selections are exclusively instrumental and band pieces. The machines will, however, play full-sized records.

If the promise of the importers of the German instruments that records in Arabic and Hindustani will shortly be available for these instruments proves true, there will be a very strong attraction for the purchase of the instruments by the wealthier classes of the population. Such records would find a ready sale in this district, for the number of old machines in the possession of families is large.

American phonographs occasionally reached this market in the pre-war days and still have the reputation of being the best, but the market has recently been almost wholly neglected by American exporters.

The consul thinks it would be well worth while for the American manufacturers to place a small, cheap machine on the Aden market, since with the cessation of intertribal warfare in the interior the back country demand for phonographs and records should be good. The phonograph is the one musical instrument which appeals with equal force to the miscellaneous races of the Red Sea district.

The voluble salesman who drives customers from the store because he did not know when to stop talking is a poor investment. It is a well-known fact that the fellow who talks the loudest and longest often has the least to say.



**Okeh Records**

GRANBY PHONOGRAPHS  
MASTER-TONE TALKING MACHINES  
OUTING PORTABLES

**NEEDLES**

Okeh — Truetone — Wall Kane  
Tonofone — Gilt Edge

Delivery Bags, Accessories, etc.

Complete Stocks—Prompt Service

**IROQUOIS SALES CORPORATION**

Wholesale Distributors

210 Franklin St. BUFFALO, N. Y.

**NEW VICTOR RECORD SALES MANUAL**

Latest Edition of Helpful Volume Just Issued—  
Has Proven of Great Practical Value

There has just been issued by the Victor Talking Machine Co. the 1922 edition of the Victor Record Sales Manual, previous editions of which have proved of tremendous value to Victor salesmen throughout the country.

The book was originally tried out in connection with the classes in salesmanship at the Victor factory and its value thus established. Since being issued to the trade at large, it has proven a distinct factor in improving the caliber of record salesmanship in many quarters.

The volume contains carefully classified lists of all records in the Victor catalog for 1922 except dances and selections in foreign numbers. The records are classified according to types of music offered, according to voices, such as bass, tenor, etc., according to various periods of the year, such as Easter and Christmas, and are otherwise classified so carefully that the record salesman has but to learn of the general desire of his customer to be able to offer a series of records all calculated to meet that particular desire.

The opening page of the book gives general instructions for utilizing the information contained therein, and there are blank spaces under each classification to be filled in by the salesman from the current supplements, thus keeping the volume up to date for reference purposes. This is but another of the many practical sales helps that have been established for the benefit of the Victor trade.

**INTRODUCES THE CLAROPHONE BANJO**

The Fred Gretsch Mfg. Co., manufacturer of musical instruments, has announced a new banjo named the Clarophone, which was designed to meet a popular-priced demand. The Clarophone is in three models, consisting of a tenor banjo, banjo-mandolin and a banjo-ukulele, and has an improved resonator back and sound holes. The Clarophone has been developed particularly for Summer selling, when price is more important than during the Fall and Winter, although it is expected that the new instrument will have an all-year-around demand. It is made entirely of maple, with rock maple rim and neck, and it is planned to retail this instrument at \$15, allowing an adequate profit to the dealer, and it is said that the new instrument compares very favorably, indeed, with many higher-priced banjos. The tone value is notable and is a surprise to the dealers who have seen this new instrument.

**Sherburne Automatic Stop**

*The Stop that Actually Stops*

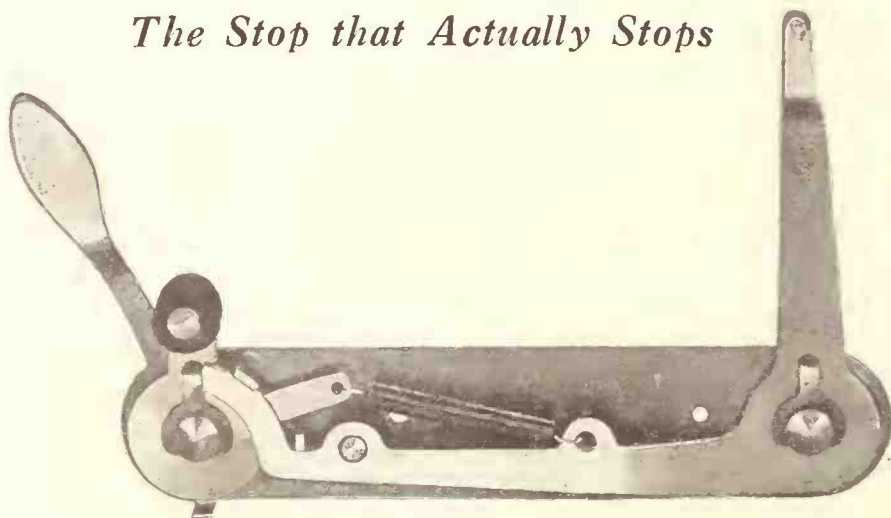

You Manufacturers who are having trouble with your automatic stop — Investigate the Sherburne Stop.

*Sample sent upon request.*

**SHERBURNE MANUFACTURING COMPANY**

948 Penobscot Building

Detroit, Mich.





## Announcement

Through an alliance recently achieved, Jewett will be represented in Detroit by the

**Max Strasburg Co**  
1264 Library Avenue

Mr. Strasburg is Michigan's pioneer phonograph merchant.

His choice of the Jewett was based on a long and searching investigation in which Jewett superiority was carefully analyzed and elaborately proved.

This alliance of Jewett and Strasburg is typical of many similar arrangements in steady process of ratification everywhere.

Far-seeing phonograph merchants desiring a medium for their salesmanship on which they can rear a growing and permanently profitable business are showing universally an increasing preference for the Jewett line.

**JEWETT PHONOGRAPH CO.**  
DETROIT, MICH.

**JEWETT**  
PHONOGRAPHS



Style No. 5  
\$125

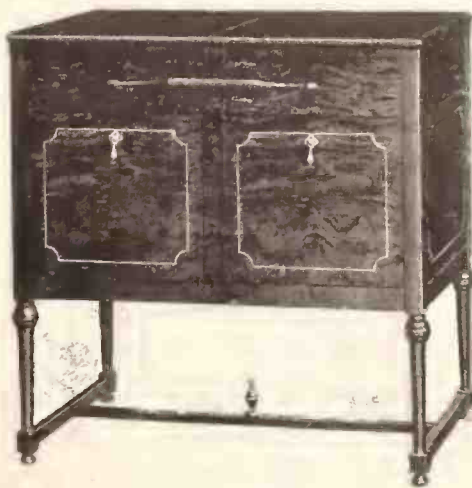

Style No. 9  
\$185



Style No. 7  
\$175





Only lead feet can resist the wheedling, tricky accordion playing of Guido Deiro. Here is a pair of fox-trots that will make the heaviest feet get happy. "You Won't Be Sorry" and "Mona-Lu." You'll say he can play. A-3620.

Columbia Graphophone Co. NEW YORK

# COLUMBUS

*Business Volume Increasing Steadily — Greenfield Piano Co. to Move—Month's News*

COLUMBUS, O., July 3.—According to F. L. Fritchey, special representative of the Perry B. Whitsit Co., Victor wholesaler, the talking machine business is slowly increasing in volume, particularly in the rural districts. "In traveling through the various parts of Ohio," said Mr. Fritchey, "I find that some dealers make a large portion of their sales by developing new prospects and selling machines through sound salesmanship talk to old prospects."

The Greenfield Piano Co., Victor dealer, of Greenfield, O., will shortly move to a new location in the Public Square, which is considered the best location in that city. Not only will all the fixtures be changed and improved, but the floor space will be doubled. This additional room will enable the firm to install more sound-proof booths than it formerly had and offer more conveniences to its patronage in other ways. Oscar Heidingsfeld and D. R. Cowman are the owners of this concern.

The Spence Music Store, Zanesville, O., reports a remarkable sale of records during the school

year. So far advanced is the music appreciation course in that city that during the last year there were enough Victrolas in the public schools to permit one Victrola to each floor and both the Board of Education and the students have been instrumental in building up a large record library.

Through the co-operation of the Home Furniture Co., Athens, O., with the Ohio University, located in the same city, the Victor Co.'s literature has been introduced in that university and the books entitled "What We Hear in Music" and "Music Appreciation for Little Children" are used in the music department. Both Victrolas and Victor records are also used for demonstration purposes and concerts in the music department of this institution.

Miss Edna Gray, of the Wainwright Music Store, Marietta, O., has been in California since the early part of March. Returning from the West, Miss Gray will visit many places of interest, including Yellowstone National Park.

"Business has picked up splendidly in the last week," said E. M. Levy, of Heaton's Music Store, 168 North High street. "Victor machine business is particularly good. Our record business has also improved considerably." At the present time carpenters have about completed enlarging the display windows of this firm.

F. J. Connor, manager of the Victrola department of the Z. L. White Co., 106 North High street, gives an encouraging report on the in-

crease of business during this month in comparison to last month.

W. F. Davisson, vice-president and general manager of the Perry B. Whitsit Co., returned last month from the convention of the National Association of Talking Machine Jobbers at Atlantic City very enthusiastic regarding the success of the meeting. Mr. Davisson was elected secretary of this important Association.

## NEW PLAN TO SELL RECORDS

Illustrated Chart Prepared for Popular Odeon Record—Chart Illustrating Song Is Sold Together With Record—A Novel Proposition

The foreign record division of the General Phonograph Corp., New York, has just worked out a new plan to sell records by illustrating the song with pictures that are sold together with the

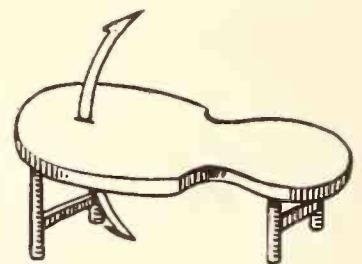

## IST DAS NICHT 'NE Schnitzelbank?—

Odeon Record Song Chart

record. The first selection to be introduced in this way is the famous German song, "The Schnitzelbank," and the General Phonograph Corp. has prepared a chart of distinctive and humorous drawings illustrating the various paragraphs in the song. This chart is sold together with the record and dealers who have visited the company's headquarters in the past few weeks are enthusiastic regarding the sales value of this new plan.

The Odeon record of "The Schnitzelbank" is made up in two parts and is sung by the well-known German comedian, Paul Bendix. The first part begins with a few humorous verses, with orchestra accompaniment, and is followed by Mr. Bendix in a comical monologue explaining just how "The Schnitzelbank" was conceived. The second part features twelve entirely new subjects in the usual way, and is also sung with orchestra accompaniment. The chart that has been prepared to accompany the record shows twenty-four illustrations, twelve of which are mentioned in the record. The additional twelve are supposed to be sung by the purchasers of the record and their friends, giving a community spirit to the rendition of the song.

"If the mountain will not go to Mohammed, Mohammed must go to the mountain," quoted a prominent dealer in an interview recently in explaining the reasons for his success. "The answer to the whole question is sustained effort," said this merchant.



HENRY BURR



ALBERT CAMPBELL



JOHN MEYERS

## EIGHT FAMOUS VICTOR ARTISTS

In Concert and Entertainment Personal Appearance of Eight Popular Victor Favorites on One Program

A live attraction for live dealers and jobbers

Bookings now for season 1922-1923 Sample program and particulars upon request

P. W. SIMON, Manager 1658 Broadway New York City



FRANK CROXTON



MONROE SILVER



BILLY MURRAY



FRED VAN EPS



FRANK BANTA

Famous Ensembles including Campbell & Burr - Sterling Trio - Peerless Quartet



**OGDEN SAYS IT'S TIME TO GET BUSY**

Prominent Cabinet Man Sends Out Forceful Letter Telling of Improved Conditions and Urging Dealers to Increase Their Activities

A betterment in general business conditions is reported from various sections of the country. Rush business in other industries that were formerly very quiet is a strong indication of the good business that can be safely expected during the Fall and Winter season in the talking machine industry. In many lines experienced workmen are at a premium and generally increased employment throughout the country is bound to enlarge the buying power as it affects our industry.

J. B. Ogden, president of the Ogden Sectional Cabinet Co., Lynchburg, Va., has pointed out, for the benefit of the talking machine dealer, many of these optimistic signs and has also incorporated in a letter addressed to the trade some excellent suggestions and how to take advantage of these opportunities. The letter states in part:

"A runaway market on lumber for building purposes is a result of an unprecedented home-building boom. Building and hardware manufacturers are 'sold up' for Fall delivery. More auto-camp equipment was sold in April and May than in the past two years. The main highways are getting full to the point of a procession. Many are out for cross-country trips and more automobiles were sold in May than in the four months previous. This looks as though the hard times were behind us; anyway, people are spending money.

"This should benefit every dealer—if he is willing to work.

"Get a list of new homes now. Find out who is going or gone camping and by mail and personal calls suggest the outfit best suited to each condition. Drop an invitation in the cars that stop over in garages at night (if you can't meet them personally). You will be surprised how many will welcome a little music and then note how easy it is to sell a portable that will fit in a small nook.

"But before they come 'stack the deck' and 'deal out' some good old familiar hymns or songs your mother sang, also instrumentals that put the tickle in the feet and bores under the skin. Then if you can't get business we suggest a change—for instance, the undertaker. He sits and waits till they die and someone has to spend money, but without getting the pleasure received by exchanging cash for musical joy."

**PAGING GUESTS BY RADIOPHONE**

Boston Hotel Adopts This Plan and Eliminates Noisy Boy Pages

BOSTON, MASS., July 1.—This city now boasts paging by radio in one of its first-class hotels. The plan is operating most successfully at the Hotel Essex, near the South station. There is no longer a "flock" of noisy boys running through the main dining-room shouting names of various guests wanted at the telephone desk. Instead, the soft but distinct voice of the telephone operator is sent out to various parts of the hotel through devices from the telephone switchboard.

"Mr. Brown is wanted on the telephone—Mr. Brown on the telephone," calls the operator into a transmitter beside her switchboard, and out in the hotel her tones are carried by amplifying apparatus.

**HAHNE & CO. OPEN BRANCH STORES**

Extend Business by Opening Stores in Butler and Boonton—Display Talking Machines

NEWARK, N. J., July 5.—The music department of Hahne & Co., this city, has opened two branch stores in Boonton and Butler in an effort to extend its activities. In addition to the pianos handled here the Victor, Sonora and Widdicomb talking machines are on display. Frank McClusky, of the sales staff of the local store, is in charge of the Boonton branch and Jack Henderson, of the local store, manages the Butler store.

**McCORMACK'S VOICE UNIMPAIRED**

Famous Tenor Sings at Birthday Party at Summer Home Outside of London—Entertains American Friends Who Enthuse Over Him

According to a dispatch from London to the New York Herald, John McCormack's voice has not lost any of its richness through his illness. The popular tenor and Victor artist demonstrated that to a select gathering of friends, including many American singers, who assembled at his country home outside of London recently to celebrate his thirty-eighth birthday. A day or two before his birthday Mr. McCormack drove into London, made a tour of the leading hotels, picking up all the friends he could find, and sent them in motors to his place. Among the notables present were: Clarence Whitehill, Barbara Maurel, Mischa Elman, Vladimir de Pachmann, Fred Powell, Charles Wagner, his manager; Madge Titheridge and Mary Anderson de Navarro. The tenor, looking almost his old-self, but slightly thinner and paler, presided at an informal dinner, which was made delightful by

his high spirits as well as charming personality. His friends naturally were very anxious about his voice. He kept assuring them that it was as good as ever, and when they appeared still unconvinced he sang for them. In "Asthere" and a cradle song, both of which are familiar to record lovers, he convinced his friends that his voice was as charming and pleasing as ever. Mr. McCormack's voice continues to be exceedingly popular in English homes, and the increased sales of his records since his illness has almost equaled the rush for Caruso's since his death.

**THALLMEYER ON LONG TRIP**

A. Thallmeyer, manager of the foreign record department of the General Phonograph Corp., New York, left Wednesday, June 28, for a two months' trip. According to his present plans, Mr. Thallmeyer will visit Okeh jobbers and dealers throughout the Central West, co-operating with their sales organizations in the introduction of plans that will develop the demand for foreign language records.

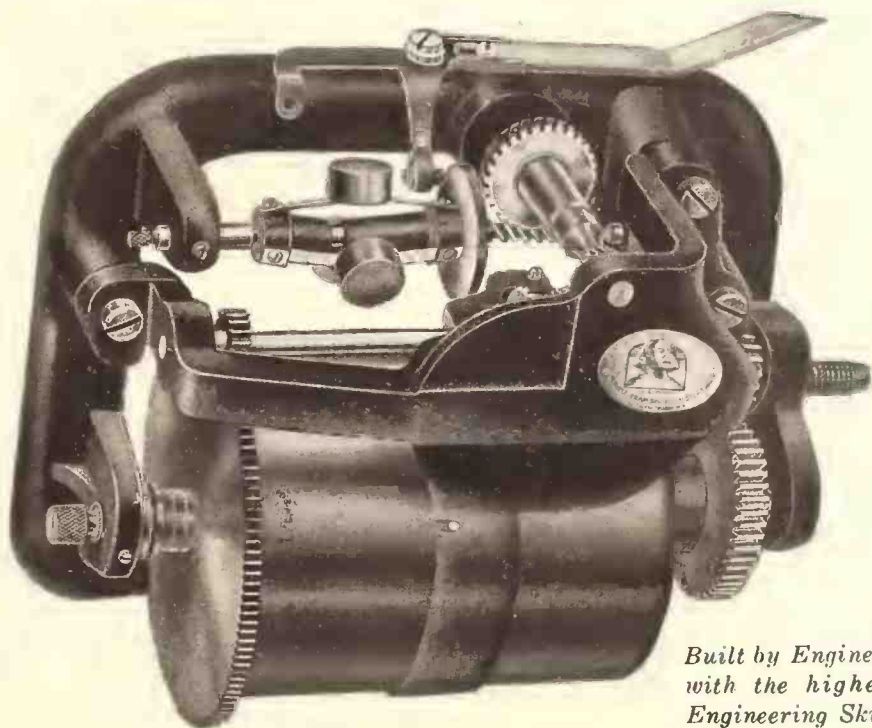

*Built by Engineers with the highest Engineering Skill.*

**D**ESIGNED to stand the shocks of hard usage.

**B**UILT to run smoothly and noiselessly under varying conditions.

**O**PERATED with uniformity, and constant in speed.

*Write for prices*



**Sphinx Gramophone Motors Inc.**

21 East 40th St.  
NEW YORK CITY



**DON'T  
SHOW  
THIS  
GAME  
IN  
YOUR  
WINDOW**

*The* **Phonogame**

Prices To You:		
	Per Doz.	Profits
1 doz.	\$8.00	50%
2 doz.	7.50	60%
6 doz.	7.00	71½%
12 doz.	6.00	100%

Retails Easily  
for \$1.00

**—until**

you first prepare for enormous, immediate sales. You won't be able to supply the public demand for these Phon-O-Games the first four weeks you have them in your store. Phon-O-Game actually sells itself on sight and every sale brings at least three more. Profits to you are 50% to 100% (see price list above). Put the Phon-O-Game on the phonograph and watch the crowds collect. What's more, watch your cash register get into action.

## Sure Sales and Rapid Turnover Assured by Our Advance Sales Test

Before offering you the Phon-O-Game as a business booster we thoroughly tested its selling value and thus proved in advance that there is a tremendous natural demand for this game. One dealer in each of seven towns was selected for the test. **IN THREE DAYS SALES RAN UP TO 92 DOZEN PHON-O-GAMES, SHOWING AN AVERAGE DAILY PROFIT OF \$19.92 per dealer!**

## Description of the Phon-O-Game

Consists of (1) a 12-inch disc resembling a record; (2) a chart of "key" numbers on heavy Kraft paper, size 24 x 30 inches; (3) a brass pointer; (4) official rules. Attractively packaged, with full color illustration on the front. Disc contains 36 red and black numbers and 2 "zeros." To play, spin the disc on phonograph, like any record; apply brake; pointer indicates winning number. Five hundred points win game. Can also be played in other interesting variations as shown in rules. Green section on disc also makes this a PUT AND TAKE game. Two games in one. For home, clubs, parties, entertainments, camps, or wherever men meet for a *sociable* time. A fun-maker for your customers, a money-maker for you.

Mail in your order at ONCE  
or write for FREE sample

Dealers sending orders for 2 to 6 dozen will be given the privilege of earning the lower price on larger quantities if the second order is placed within 10 days after the first order.

**The Phon-O-Game Company**

128 Fulton Street

Elizabeth, N. J.



**Big news! Eddie Cantor has signed up to record exclusively for Columbia. On the August list you'll find his first—two typical Cantor songs. "I Love Her—She Loves Me" and "I'm Hungry for Beautiful Girls" from "Make It Snappy." Both are on the one record. A-3624.**

**Columbia Graphophone Co.  
NEW YORK**



**STRIKING SUMMER DISPLAY WINDOW**

Camping Scene Featuring Portable Victrola Planned by C. Bruno & Son, Inc., a Sales Producer—Popular With Dealers

The window display of the camping scene featuring the portable Victrola, which was shown in the window of William Waldman, Victor retailer, located at Forty-third street and Ninth avenue, New York City, was such a decided success that three duplicates were made of it by C. Bruno & Son, Inc., Victor distributors, New



**Bruno Window Much in Favor**

York City. The original display in Waldman's window was planned by C. Bruno & Son, Inc., and successfully executed by E. G. Evans, of that organization. It has proved an actual sales producer. Mr. Waldman reports that he has traced four sales directly to it, one amounting to \$90.

The display is not a cardboard cut-out, but all real. The window consists of an outing-clad figure, with pipe in hand and sitting on a tree stump, listening to the Victrola located on an adjacent stump. A regulation "pup" tent, log camp fire, camp cooking and dining equipment, canoe paddle, fishing tackle and grass mat are among the other material used, together with a big drop-curtain of a lake scene. Through the means of blue and green electric bulbs many artistic lighting effects can be obtained, such as twilight, daylight and night effects. The display is adaptable to any window of a minimum five-foot depth and six-foot width.

C. Bruno & Son, Inc., have placed these four displays at the disposal of their Victor retailers and are putting them out on a small rental basis for a period of two weeks to each dealer.

The demand for the displays has been so heavy that it has already become a problem to arrange the bookings, as all four are booked solid for some weeks ahead. The display has proved an undoubted success in stimulating interest in portable models.

**COTTON FLOCKS**

.. FOR ..

**Record Manufacturing**

**THE PECKHAM MFG. CO., 238 South Street, NEWARK, N. J.**

**HARRY GENNETT HEADS STARR CO.**

Former Vice-President Elected to Succeed the Late Henry Gennett

RICHMOND, IND., July 5.—The Starr Piano Co. of this city, has announced the election of Harry Gennett, formerly vice-president of the company, to the position of president to fill the vacancy occasioned by the recent death of Henry Gennett. Harry Gennett has already assumed his new duties, with which he is quite familiar.

The Secretary of State has authorized the increase of the capital stock of the Starr Piano Co. from \$200,000 to \$2,500,000. Of this latter sum \$1,000,000 is common stock and \$1,500,000 is 7 per cent preferred stock. A stock dividend of 300 per cent has been declared payable to the common stockholders in the new common stock. The balance of the common stock and the preferred stock remain in the treasury of the company, but will be used to advance the interests of the company, particularly to further extensions of the plant at Richmond, Ind., and the Gennett Recording Laboratories in New York.

**BRICK'S MUSIC HOUSE CHARTERED**

Brick's Music House, of Brooklyn, N. Y., has been granted a charter of incorporation in this State, with a capital of \$5,000. The concern, which will deal in talking machines, was incorporated by C. and M. Brick.

**MAKES ENVIABLE SALES RECORD**

Columbia Dealer Sells 132 Grafonolas in Less Than Eight Weeks—Intensive Sales Drive Produces Results of Satisfactory Kind

BREWTON, ALA., July 6.—Grafonolas to the number of 132 sold in less than eight weeks is the record of the Hainje Specialty Co., of this city, as the result of a strenuous advertising campaign, which was coupled with efficient and intensive salesmanship. J. A. Hainje, president and general manager of the company, seems to be determined to place a Columbia Grafonola in every home in this section, and at the present rate he is moving will undoubtedly reach his goal. The 132 Grafonolas sold in less than eight weeks represented a carload shipment and the Hainje Co. accomplished what was considered the miraculous in disposing of these instruments in such a short while. Starting business here a few years ago Mr. Hainje has specialized in the sale of Columbia Grafonolas and records. While he deals in other lines of household specialties the Columbia line is handled exclusively in his music department, and his record business is increasing so rapidly that additional facilities will soon be required to meet the demands of a growing clientele.

The Belvidere Disc Co. was recently incorporated in New York, with a capital of \$25,000, by J. Black, E. E. Efron and S. Baum.

**FELT**

*We are prepared as never before to give prompt delivery.*



**Turntable Felt**

The name of a special product made by the American Felt Company for the Talking Machine Trade.

It possesses features which distinguish it from Felts made by this company for other purposes.

Only our special Turntable Felt is good enough for leading Talking Machine Manufacturers, who use it exclusively.

**American Felt Company**

TRADE MARK



BOSTON  
100 Summer St.

NEW YORK  
114 East 13th St.

CHICAGO  
325 So. Market St.



# Reasons

# Sonora



# is the easiest

## \$50.00



The Sonora Portable is the surest cash-sale maker for the summer months ever offered to phonograph dealers. It is the easiest portable to sell because it combines in the highest degree possible the two qualities a portable should have—compactness and tone quality.

**Easiest to Carry.** The Sonora Portable is not only small and conveniently shaped for carrying, *but weighs only 16 lbs.*

**Large Record Capacity.** Carries 18 records in perfect safety in its own case—enough for many weeks' outing.

**Finest Tone Quality.** With the utmost economy of space and bulk, the Sonora Portable has been so scientifically developed that its tone quality is typical of the clarity and volume for which Sonora is famous.

**Handsome in Appearance.** As a traveling piece the Sonora Portable—with its cover of genuine calf-skin—excites the same admiration produced by the finest English hand-luggage.

## The Highest Class Talking

**Gibson-Snow Co.,**

Syracuse, N. Y.  
State of New York with the exception of towns on Hudson River below Poughkeepsie and excepting Greater New York.

**Griffith Piano Co.,**

605 Broad St., Newark, N. J.  
State of New Jersey.

**Hessig-Ellis Drug Co.,**

Memphis, Tenn.  
Arkansas, Louisiana, Tennessee, Mississippi.

**Kiefer-Stewart Co.,**

Indianapolis, Ind.  
State of Indiana.

**Lee-Coit-Andresen Hardware Co.,**

Omaha, Nebr.  
State of Nebraska.

**M S & E,**

221 Columbus Ave., Boston, Mass.  
Connecticut, Rhode Island, Massachusetts, Maine, New Hampshire and Vermont.

**C. L. Marshall Co., Inc.,**

514 Griswold St., Detroit, Mich.  
Michigan, Ohio and Kentucky.

**The Magnavox Co.,**

616 Mission St., San Francisco, Cal.  
Washington, California, Oregon, Arizona, Nevada, northern Idaho, Hawaiian Islands.

**Southern Drug Company,**

Houston, Texas.  
Southeastern part of Texas.

**Southern Sonora Company,**

310-314 Marietta St., Atlanta, Ga.  
Alabama, Georgia, Florida and North and South Carolina.

**The Fox-Vliet Drug Company,**

Wichita, Kans.  
Southern part of Kansas, Oklahoma (except 5 N.E. counties) and Texas Panhandle.

**Doerr-Andrews-Doerr,**

Minneapolis, Minn.  
States of Montana, North Dakota, South Dakota, Minnesota.



# Why the

# Portable

# portable to sell

**Most Compact.** Its dimensions, 14½ in. x 14½ in. x 9 in., make it possible to tuck the Sonora Portable away in almost any space, in the canoe, motor, motor-boat or tent.

**Best Materials Throughout.** In addition to the calf-skin cover, the Sonora Portable is provided with stout spring-locks, strong leather handle, and nickel-plated trimmings.

**A Full-fledged Phonograph.** The Sonora Portable is equipped with a substantial motor of double-spring type, large amplifying chamber, regulation tone arm, and plays all makes of disc records, including diamond point and sapphire ball records.

**Guaranteed.** Like all Sonora phonographs, the Sonora Portable is covered by a guarantee expressing the full confidence of the manufacturer.

Sell this wonderful money-maker this summer. Write the jobber in your territory for particulars. (See list below.)

## \$50.00

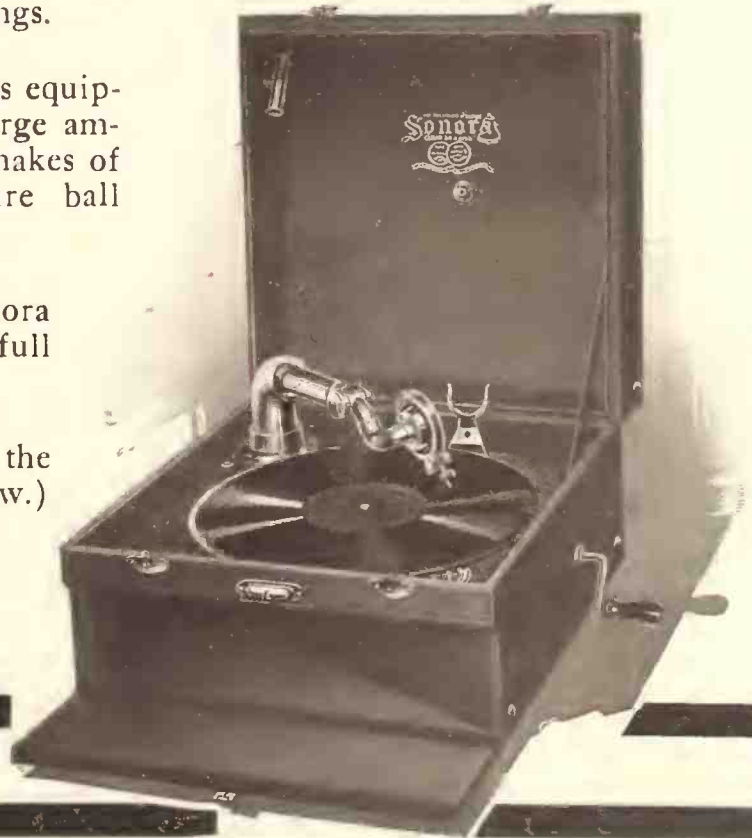

## Machine in the World

**C. D. Smith Drug Co.,**

613 Arcade Bldg., St. Louis, Mo.  
St. Joseph, Mo.

Missouri, northern and eastern part  
of Kansas and 5 counties of N.E.  
Oklahoma.

**Moore-Bird & Co.,**

1751 California St., Denver, Colo.

States of Colorado, New Mexico and  
Wyoming east of Rock Springs.

**Strevell-Paterson Hardware Co.,**

Salt Lake City, Utah.

Utah, western Wyoming and south-  
ern Idaho.

**C. J. Van Houten & Zoon,**

720 S. Michigan Ave., Chicago, Ill.

Illinois and Iowa.

**Yahr & Lange Drug Co.,**

Milwaukee, Wis.

Wisconsin, Upper Michigan.

**Sonora Co. of Phila., Inc.,**

1214 Arch St., Philadelphia, Pa.

Eastern Pennsylvania, Maryland, Del-  
aware, District of Columbia and Vir-  
ginia.

**Sonora Dist. Co. of Pittsburgh,**

505 Liberty Ave., Pittsburgh, Pa.

Western Pennsylvania and West Vir-  
ginia.

**Long Island Phonograph Co.,**

150 Montague St., Brooklyn, N. Y.

All of Brooklyn and Long Island.

**Greater City Phonograph Co., Inc.**

311 Sixth Avenue, New York.

Counties of Westchester, Putnam  
and Dutchess; all Hudson River  
towns and cities on the west bank of  
the river, south of Highland; all ter-  
ritory south of Poughkeepsie, includ-  
ing Greater New York, with the ex-  
ception of Brooklyn and Long Island.



**PONSELLE AT TEXAS RADIO STATION**

Famous Columbia Artist Broadcasts at Kelley Field—San Antonio Concert a Signal Success

Upon her recent visit to San Antonio, Tex., Miss Rosa Ponselle, famous operatic soprano and exclusive Columbia artist, was prevailed upon to have her voice broadcasted at Kelley Field, where the United States Government radio station is located. The singing radius of this station is 2,000 miles and Miss Ponselle's concert was heard in Laredo, Brownsville, Eagle Pass and El Paso.



Miss Ponselle at San Antonio

At the concert that she gave in San Antonio Miss Ponselle was obliged to give fourteen encores and the newspaper critics devoted considerable space to the wonderful performance given by this famous operatic soprano.

**MAX LANDAY "SOME" GOLFER**

Max Landay, of Landay Bros., the prominent Victor dealers of New York City, recently spent a few weeks' vacation at beautiful Otsega Lake and Cooperstown, N. Y., accompanied by his wife and family. He participated in the annual golf tournament of the American Association of Advertising and displayed quite some form in this ancient and honorable game of the Scots, which has been so wisely adopted by wide-awake Americans as a means of relaxation and physical well-being.

**DIRECT FACTORY PRICE—JUST MENTION THE QUANTITY**

<b>MOTORS</b>	<b>CASTINGS</b>	<b>TURNTABLES</b>	<b>Stylus Bars</b>
<b>TONE ARMS</b>	Grey Iron	<b>MOTOR FRAMES</b>	<b>Screw Machine Parts</b>
<b>REPRODUCERS</b>	and Brass for	<b>TONE ARMS</b>	<b>Talking Machine Hardware</b>
		<b>HORNS and THROATS</b>	

Direct Quantity Importations On { JEWEL and STEEL. (Bulk or Packed)  
PHONOGRAPH NEEDLES  
GENUINE RUBY BENGAL MICA

**D. R. DOCTOROW**

Vanderbilt Ave. Bldg.  
51 East 42nd Street, New York  
Tel. Vanderbilt 5462  
Murray Hill 800

**C. ALFRED CLARK A REAL SAILOR**

Managing Director of Gramophone Co., Ltd., Has Crossed the Ocean Seventy Times

One of the interesting personages who attended the convention of the National Association of Talking Machine Jobbers at Atlantic City last month was C. Alfred Clark, managing director of the Gramophone Co., Ltd., London, England, who spent some weeks in conference with the Victor Co. officials. While Mr. Clark was being introduced at the convention a newspaper man saw a real opportunity of asking the conventional question: "What do you think of the United States?" "Quite well," replied Mr. Clark. "You know this is my seventieth crossing." The laugh was general. Mr. and Mrs. Clark sailed for home late in June.

**MAKES PLEA FOR THE RECORD**

Recently in one of the large hospitals an unfortunate soldier who had been severely wounded during the late war and who is now in a state of slow convalescence was so deeply impressed with the joy and pleasure caused by the music rendered on a Victor record that its frequent abuse, which often came under his observation, aroused his indignation and the poetical effusion herewith was the result of his rumination:

**A Victor Record Speaks**

No one seems to think of me,  
They keep me in a rack;  
Sometimes I'm thrown around the room,  
Or piled up in a stack,  
They only want to use me  
When they want a dance or song,  
And the way that I am treated  
Is a shame—I say it's wrong.

Don't let a worn-out needle  
Ever travel 'cross my rills,  
For if it's not sharp it scratches,  
And gives me nasty chills.  
You'll find that I'll do better,  
If you'll brush me ere I start;  
And if you do not speed me  
I'll sing and dance my part.

**ANNOUNCES NEW STARR CONSOLE**

Style 19 Added to Starr Line—Has Many Attractive Features—Dealers Pleased With Its Appearance—Plan Fall Campaigns

The Starr Piano Co., Richmond, Ind., has just introduced the Style 19 Starr phonograph, which bids fair to become one of the most popular models in the Starr line. The accompanying illustration will give some idea of the artistic



New Starr Console, Style 19

appearance of this new instrument, and Starr dealers throughout the country are planning to use the Style 19 as the basis for their Fall publicity campaigns.

This new Starr model is thirty-three inches high, thirty-six and one-eighth inches wide and twenty-one and one-eighth inches deep. Its mechanical equipment includes all of the distinctive Starr features that have contributed so materially to the success of this well-known line, and its cabinet design is in keeping with the attractiveness of the general Starr line.

**TONE ARMS for Portable Machines**  
**TONE ARMS for Medium Priced Machines**  
**TONE ARMS for High Grade Machines**

Quantity prices from **\$2** up, including sound box

Let us know your requirements and we will quote you prices

The Phillips Octagon Throw Back Arm No. 5  
Equipped with No. 3 or No. 5 reproducer  
Special Quantity Prices on Request

**The William Phillips Phono Parts Corp.**  
145 West Forty-fifth Street New York City



## The Six Essentials in Retail Store Success

By FRANK H. WILLIAMS

What are the six most essential things in making a success of a retail talking machine store?

Here's what they are, according to a successful Middle Western dealer in this special field:

- 1—The right goods.
- 2—The right prices.
- 3—A good location.
- 4—Courteous, efficient sales people.
- 5—Attention-arresting newspaper advertising.
- 6—Attractive window displays.

What are the six things you have found in your experience, Mr. Talking Machine Dealer, to be the most essential in making the success you have made of your establishment?

Certainly it does seem as though the above six things are just about as important as anything in the world in making a success of a store

unless the matter of adequate capital might be added. Certainly no dealer can sell talking machines unless he has satisfactory, well-known instruments to sell. Nor can he sell machines and records unless his goods are priced right. A merchant can, of course, get people under some conditions to come to an out-of-the-way location, but a good location is, undoubtedly, a big asset. Courteous, efficient sales people will satisfy and hold the trade while attention-arresting newspaper advertising and attractive window displays will get people into the store where the sales people can sell them.

Consider these points in connection with your store, Mr. Dealer. Are you slipping up on any of these essentials to the making of a big success in the retail talking machine business?

### COMPARES TRADE WITH A YEAR AGO

Dealers Are Too Busy to Think of Summer Dullness, Says Dun's Review

Existing business conditions contrast sharply with those of a year ago. Instead of the repressed demands of the earlier period current buying in various lines reflects breadth and activity, and price advances, rather than declines, now predominate. Less is heard at present than was the case last year of the quieting influence of the hot weather Summer months, because there is more work to be accomplished, and it is significant that the question as to whether business has improved has changed to discussion of the extent and scope of the revival.

While the recovery has actually been in progress for many months, it had come so slowly and irregularly in different quarters as not to be widely noticed, and some unsatisfactory phases had raised doubts as to the character of the forward movement. Recent statistical exhibits, however, have caused a more general recognition of the fact that the commercial situation has

taken a decided turn in the right direction, gains in iron and steel output, in building permits, in railroad traffic and in bank clearings being among the favorable indices. Supporting these and other measures of progress is the more confident sentiment in many channels and the increasing disposition to anticipate future requirements.

### GILLINGHAM SAILS FOR JAPAN

Well-known Recording Expert Joins Forces of Nipponophone Co., of Yokohama—Identified With the Industry for Many Years

Lewis E. Gillingham, one of the best-known phonograph recording experts in the East, left New York on July 1 for Yokohama, Japan,



and will be associated with the Nipponophone Co., of that city, as research engineer. Mr. Gillingham has had extensive experience in the record manufacturing industry, having been identified for more than eighteen years with the Victor Talking Machine Co. For several years he was head of the Aeolian Co.'s recording laboratory and was also general manager of the Rodebeaver Record Co. For some time past he has been associated with the engineering department of the Columbia Graphophone Co., at Bridgeport, Conn.

### A MOST ARTISTIC ANNOUNCEMENT

Fitzgerald Music Co. Tells Public About Acquisition of Brunswick Line by Means of an Unusually Artistically Prepared Folder

LOS ANGELES, CAL., July 3.—One of the cleverest and most artistic announcements of the acquisition of a line of talking machines that has been produced in a long time is that of the Fitzgerald Music Co., 727-729 South Hill street, this city, which recently added the Brunswick line of phonographs and records to its stock.

The announcement is in the shape of a folder on heavy brown stock, which bears the title on the outside, "For the Advancement of Music." The text on the inside, arranged on old ecclesiastical lines and printed in dark brown, calls attention to the tone and quality of the new line and mentions several of the famous artists who record for the Brunswick.

### MME. SCHUMANN-HEINK HONORED

LOS ANGELES, CAL., July 5.—Mme. Ernestine Schumann-Heink, world-famous contralto, was made an honorary Doctor of Music by the University of Southern California here recently on the occasion of her sixty-first birthday. Mme. Schumann-Heink will remain in California some time before returning East.

## H. N. McMenimen

Consulting Engineer

Consultation by appointment on every phase of the phonograph industry, including:

Recording, Plating and Pressing

Motor, Tone-Arm and Reproducer Design

Patent and Model Development

Sales Promotion and Advertising Plans

Laboratory:

Scotch Plains, N. J.  
Tel. Fanwood 1438

Offices:

2 Rector Street, New York  
Tel. Rector 1484



## REGAL

Regal has been a consistent leader in the popular-priced record field—from the first!



## Naturally!

Regal offers release priority—a superior quality—



—and dependable dealer service; plus—



—a larger Regal catalog to fill the wider Regal demand.



That explains Regal's leadership — quality — service!

Write us today for details!

**REGAL RECORD CO., Inc.**  
20 W. 20th ST NEW YORK





**Al Jolson has gone Coo Coo. His morning's morning of bird seed finally set him twittering and "Coo Coo" is the result. It's a scream. Frank Crumit, on the other side, comes right back with "Stumbling." We hope to be able to make enough of this record to go 'round. A-3626.**

**Columbia Graphophone Co.  
NEW YORK**

### STUDIES CAUSE OF SALES DECLINE

Interesting Results of Questionnaire Regarding Talking Machine Sales Sent Out Recently by National Retail Dry Goods Association

The National Retail Dry Goods Association, which some time ago made a very exhaustive survey of the talking machine field, particularly in relation to the handling of machines and records in department stores, recently sent out a questionnaire in an effort to discover the cause of the decline of sales in that field. The questionnaire, it must be remembered, covered talking machine conditions in the department stores in which the Association is naturally interested. It therefore does not give a fair approximation of the actual conditions in the talking machine industry, particularly as it does not fully consider the accomplishments of the small dealers, who by their individual efforts and more strenuous campaigning have built up a fairly good business when compared with the talking machine sections in the department stores. The results of the questionnaire embodied in the report give the following conclusions in part:

"From figures just received from forty-six leading stores there was evident during the months of February, March and April a curtailment of phonograph buying by the public amounting to about 15 per cent in dollars-and-cents volume as compared with the same period last year.

"On the other hand, thirteen out of the forty-six stores replying showed increases up to 146 per cent and the average increase for these stores during the months of February, March and April was about 30 per cent. These increases have been

due to special stimulation—special prices, offering lower and longer terms of payment on instalment purchases, adding more lines to give great variety to the department, featuring special low-priced machines or the introduction of other new merchandising appeals.

"Twenty-eight stores reported decreases for the same period as compared with last year's business, these running as high as 75 per cent. Numerous reasons were given for this falling-off. Several stores expressed the opinion that phonographs were essentially a luxury commodity, and the curtailed purchasing power of the public, reacting against luxuries, has, therefore, directly affected the sale of these articles. This was especially evident in replies from mid-Western stores in agricultural communities.

"The lack of construction of new homes has been given as another reason, as it was pointed out that during the last two years the intensified selling efforts made by phonograph companies have almost saturated the market, and machines will only be purchased by people opening up new homes.

"Several stores put some of the blame for the decrease on the popular interest in radio. On the other hand, a number of stores varied in this opinion, stating that radio was more of an individual hobby for men and boys, and was not a home proposition as yet, so that it could not be compared with the phonograph.

"The high prices of phonograph records was another complaint made by the stores for decreased sales. Many of the stores which have been able to increase business during this period have done so through the sale of low-priced records selling for about 49 cents."

### ENLARGE "TALKER" DEPARTMENT

L. Bamberger & Co. Open Fine New Department—Unit Construction Co. Installs Demonstration Booths—C. W. Morgan in Charge

NEWARK, N. J., July 6.—The large addition to the L. Bamberger & Co. store on Market street, this city, has resulted in greatly increasing the space of the talking machine department, which has been moved to a portion of the sixth floor adjoining the piano department.

The new location is most attractive and twenty-two sound-proof record demonstration booths have been constructed on the sides of the department, leaving the center of the floor space clear for the display of the Victor, Brunswick and Pooley machines, which the firm handles. The installation of the booths was made by the Unit Construction Co. and the department is undoubtedly one of the most handsome in this section of the State. The booths are finished in old ivory and their attractive arrangement makes this a convenient place for shoppers. The entire music department is under the supervision of W. J. Connelly, and C. W. Morgan has succeeded C. A. True as manager of the talking machine department. Mr. Morgan has had wide experience in the talking machine business.

### "A RECIPE FOR SUMMER JOY"

W. J. Dyer & Bro., Victor Distributors, Prepare Handsome Portable Folder for Distribution by Victor Dealers to the Purchasing Public

ST. PAUL, MINN., July 3.—The Victrola portable models are being featured by W. J. Dyer & Bro., Victor distributors, of this city, in a unique and clever manner. A quantity of folders for distribution by the dealers has been prepared. When closed, ready for mailing, the first thing that strikes the eye of the recipient is an illustration headed by the title, "A Recipe for Summer Joy." The obverse side of the folder contains an illustration of the Portable No. 50 with some text concerning the advantages of owning a Victrola. The inside is completely taken up with an illustration of a Victrola portable model, Style IV, on a green background. The value of the machine as a means of entertainment is cleverly brought out both in the text and the illustration.

### AVOIDING AND REMEDYING MISTAKES

Mistakes are better never made—but the next best thing when an error does creep in is a prompt report and a frank acknowledgment by the one who makes it. That shows the mistake was of the hand and not of the heart. It costs less and is better for all concerned to have an error adjusted on the spot rather than later on—and is much more satisfactory to have a mistake reported by an employe than by a customer of the house.

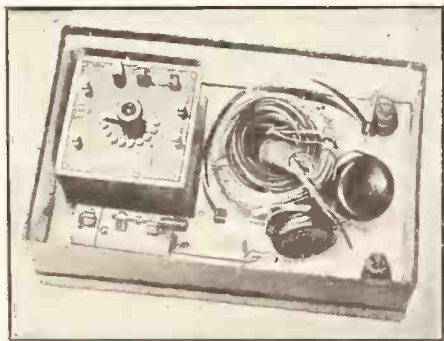

**ATLANTIC JR.**

Crystal Receiver

**\$18.00**

Ready for Installation

**Atlantic Instrument Co.**  
INCORPORATED

13-21 PARK ROW NEW YORK

**Victor  
Wholesalers**

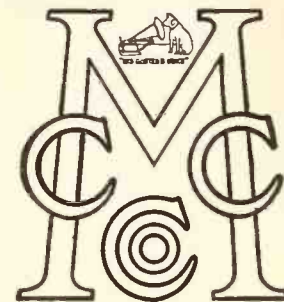

**The House  
of  
Mellor  
in  
Pittsburgh  
since  
1831**





**GEORGIA**

Irresistible Fox Trot - Full of Rhythm and Snap - It's a Hit

Proved Instantly Popular in Vaudeville  
—A Great Favorite with Dancers.

*"You can't go wrong with any 'Geist' song"*

**HEAR IT NOW!**

**EDDIE CANTOR PRESENTS COLUMBIA**

Well-known Comedian and Columbia Artist Presents Gift to Ill Theatrical Writer

Eddie Cantor, famous musical comedy and vaudeville star and exclusive Columbia artist, recently presented a Columbia Grafonola to Miss Nellie Revelle, who is at present in St. Vincent

**BUYERS OF RECORDS CANNOT PLAY THEM FOR PROFIT**

When Copyrighted Musical Numbers Are Used a License to Exploit the Records for Profit Must Be Secured From the Copyright Owner—A Legal Point of Great Interest Elucidated

An important question of law which should be understood by talking machine men recently came up in a controversy between a restaurant owner and the owner of copyrights of certain musical compositions recorded on these records. The facts as related by the Brunswick Despatch, which follow, are interesting:

The Goldstein-Migel Co., of Waco, Tex., sold a number of Brunswick phonograph records to Mrs. Pittman, who operates a café. She played these records on a phonograph in her café and was advised by the resident counsel of the American Society of Composers, Authors and Publishers that she was infringing upon copyrights owned by members of that society.

The matter raised the question as to the rights of purchasers of phonograph records in relation to the copyright law of the United States.

The Brunswick-Balke-Collender Co. obtained a competent legal opinion on the point. Reduced to its simplest and most understandable terms, the opinion is as follows:

The U. S. statutes involved state that the copyright owner has the sole right to perform a musical composition in public for profit, unless that right is waived or assigned in some way to some other party. In the case of Victor Herbert vs. Shanley Co., 242, U. S. 591, it was held by the court that where a copyright musical composition was performed by an orchestra in a hotel, this constituted a public performance for profit, although the only charge made was for the food served, there being no specific charge made either for admission or entertainment. The theory of this case was that where music is performed in a restaurant the charge for food is so regulated as to make the public pay for the music.

The copyright owner of musical compositions in making a royalty agreement with record manufacturers gives those manufacturers the right to

make and sell records in the usual way, which is for use in homes, etc.

Consequently, under this opinion, owners of cafés, restaurants, shoe shining parlors and other places operating for profit are guilty of a violation of the copyright law in playing phonograph records for their patrons, unless they comply with that law by securing a license from the copyright owner.

**TO EQUIP STORE IN GOTHIC DESIGN**

Grimmler & Co. Close Contract With Zimmerman-Bitter Construction Co. for Full Equipment of Their Store—Trade Outlook Pleases

The Zimmerman-Bitter Construction Co., New York, manufacturer of general store equipment, reports that since its entry into the talking machine field a short time ago the demand for its equipment has been very gratifying. The company is now working on four different jobs recently contracted for, and is now making bids on several others, which it expects may be turned over shortly. The latest contract secured by the company is for the complete renovation and equipment of Grimmler & Co., at 2544 Broadway, corner of Ninety-sixth street, New York City. This equipment calls for the very finest material and workmanship, and when completed will represent one of the best store equipment jobs which it has yet installed. The general scheme is to be of Gothic design in the interior of the store, while the show window is to have the appearance of French windows. Officials of the company are very enthusiastic over the way its product has been received by the trade in general, and it is expected that in a short time the company will be firmly established as a manufacturer of high-grade store equipment.



Eddie Cantor and the Columbia Grafonola Hospital, New York. Miss Revelle is one of the best-known members of the theatrical world, having formerly been a prominent press representative and now doing special writing for the leading theatrical magazines. Miss Revelle has been confined to St. Vincent Hospital with spine trouble for the past three years, and Mr. Cantor presented her with the Columbia Grafonola to relieve the tediousness of her confinement.

**EQUIP TRUCKS WITH RADIOPHONE**

Many merchants throughout the country are taking advantage of the radio for publicity purposes, which in some instances are of a unique character. Several concerns in the West have even equipped their delivery trucks with a radiophone and as the machine is driven through the streets the news and music is received from the broadcasting stations and amplified for the delectation of pedestrians.



**TRUCKS**

The Lea Phonograph and Talking Machine Truck must be used to be appreciated.

With it one man can handle the Edison Chippendale, Victor No. XVII, Cheney No. 6 Queen Anne and other large models. This truck also fits the smaller sizes.

It is only a one-man job to deliver your instrument from the showroom to any apartment floor.

Piano trucks, hoists, covers, straps, movers' supplies. May we send you a circular and prices?

Made only by

**Self Lifting Piano Truck Co.**  
FINDLAY, OHIO





*"The Records of Quality"*

"A line no live dealer can afford to be without."

"One sale makes a steady customer for Okeh."

## SO SAY THE Okeh DEALERS!

We link up these superior Records with Consolidated Service — filling your orders promptly in every case. We can help you make your business grow if you will give us the opportunity. It will pay you to investigate.

*Write Us For Our Dealers' Proposition*

# Consolidated Talking Machine Co.

227 W. Washington St.

Chicago, Ill.

Branch: 2957 Gratiot Ave., Detroit, Mich.



## AEOLIAN CO. HOLDS ANNUAL OUTING AND BALL GAME

Piano Department Team Wallops Vocalion Team in Exciting Contest—Game Followed by Elaborate Dinner With T. H. Fletcher Acting as Toastmaster—Entire Affair Most Enjoyable

Over seventy members of the executive and sales staffs of the Aeolian Co. attended the annual outing and baseball game held at Tarrytown, N. Y., on Saturday, June 24, and voted it the most successful outing of the series. It was an ideal day, particularly in the country, and the majority had the privilege of enjoying the motor trip along

of the runs on his side. A look at the score will prove how hard he worked.

A homer in the ninth inning and some sensational playing on both sides served to excite the spectators, who were interested in a pool on runs and who took pleasure in eliminating various individuals as the number of runs increased. When



The Aeolianites at Their Annual Baseball Game

1—The Winning Piano Department Team. 2—The Vocalion Team. 3—Cliff Hess Leans on the Pill. 4—The First Hit. 5—Laurino Fans Again

the Hudson from New York to the scene of the picnic.

The baseball game was the first feature and, as usual, was held on the grounds of the Hackley School, where the participants had the use of the magnificent pool, the showers and other facilities. The team representing the piano department cleaned up again, winning over the Vocalion team by a score of 18 to 2. The score, however, did not indicate as it should the excitement of the game, for there were some real ball players in the field and some of the plays would have done credit to big league stars.

C. A. Laurino captained the winning piano team, and did some sensational work to the plaudits of the gallery. Laurino had charge of the arrangements of the outing, as usual, and naturally felt it incumbent upon him to give those in attendance the proper amount of action. Cliff Hess and his cigar helped in keeping the Vocalion team from facing the disgrace of a shut-out, but Charlie Tracy, of the Vocalions, although walloped on the knee by a ball, bragged loudly that he was responsible for 50 per cent

of the nineteenth run seemed to be the limit Moe Stein opened up his heart and his flask, but when the final twentieth came in he closed down tight on both.

There was talk at one time of members of the Vocalion team chipping in for a pair of glasses for Frank Nichols, the umpire, it being declared that his eyesight failed just as the ball passed the plate and that his guesses were generally wrong. Hess declared that his nose was grazed by a ball officially announced as a strike.

Following the game and the settlement of the various disputes—friendly, of course—arising therefrom the party adjourned to the Philipse Manor Yacht Club, where they enjoyed an elaborate menu amid the very pleasant surroundings. After the dinner T. H. Fletcher, manager of the retail department of the Aeolian Co., assumed the role of toastmaster and introduced several speakers, including Charles Goldman, president of the Bronx Board of Trade; C. A. Laurino, C. Arthur Longwell, Moe Stein, manager of the Bronx branch of the Aeolian Co.; D. F. Cordingly and several others. A number of

verses appropriate to the occasion were sung by the gathering, and a particular hit was made by some special parodies on members of the Aeolian staff, written and sung by Cliff Hess.

### CLEVER COLUMBIA EXHIBIT

Display of Products Used in Making Columbia Records Attracts Attention

BRIDGEPORT, CONN., July 6.—A "Made in Bridgeport Week" was held here recently, in which the products manufactured by local firms were given special prominence in windows and stores of the city. Conspicuous among the displays was an exhibition of Columbia Graphophone products featured by the George B. Clark Co. The process of making a record was exhibited here; the various products used in record manufacture were displayed and a number of Columbia machines were also shown. The display attracted considerable attention.

### THREE NEW VICTOR DANCE RECORDS

Victor Co. Announces Special Release of Dance Records Which Were Put on Sale on July 14

The Victor Talking Machine Co. has announced the release of three splendid new dance records, which were ready to be placed on sale by the retail trade on July 14. The first of the records bears "Lonesome Mama" and "Memphis Blues," fox-trot, played by the Virginians; the second, "Soothing," played by the All-Star Orchestra, and "Night," played by the Club Royal Orchestra, and the third, "It's Up to You" and "'Neath the South Sea Moon," fox-trots, played by Whiteman and his orchestra.

### JAMERSON MUSIC HOUSE OPENS

St. LOUIS, Mo., June 26.—The Jamerson Music House, the latest addition to the music stores of this city, was recently opened at 223 Collinsville avenue, with a complete line of pianos, player-pianos, talking machines and small musical instruments. The members of the firm are E. W. Jamerson, well known in musical circles as an accomplished pianist; Charles E. Scruby, also a prominent musician, and Eugene F. Schirmer.

### OPTIMISTIC OVER OUTLOOK

A. L. Jewett, general traveling ambassador for the Starr Piano Co., makers of the Starr piano and Starr phonographs, in Richmond, Ind., was a visitor to New York the early days of the month, and in a chat with The World expressed himself as optimistic regarding the general outlook for the talking machine trade next Fall.

Model 17. Mahogany, Golden Oak or Fumed Oak, 75-record file. Emerson music-master horn. Exposed metal parts gold plated. A beautiful machine worth many, many dollars more than we ask.

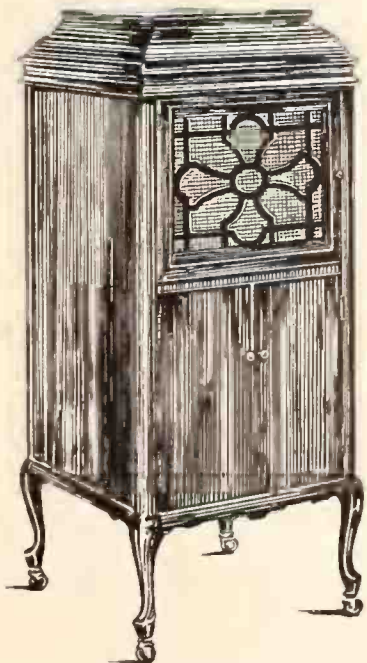

# Emerson Phonographs

at startling low prices

WHAT would it mean to you to be able to offer your customers a beautiful, nationally known, high-grade Emerson Phonograph at a price so low that it seems ridiculously impossible—and yet be able to make a fine profit on them? You can do so. We have a number of Emersons, fine, new machines, which we made up for the Emerson Co., which we can sell you at a price you will scarcely believe possible. We want to break even and that's all. You and your customers get the benefit. You know the Emerson—how really high grade it is—and what a splendid reputation it has. Cash in on this real buying opportunity!

Write for full information

The UDELL WORKS :: Indianapolis

28th Street and Barnes Avenue



# ANNOUNCING



## THE STYLE XIX STARR PHONOGRAPH

### STYLE XIX

Oak, Walnut or Mahogany

Height, 33 inches; width, 36 $\frac{1}{8}$  inches; depth, 21 $\frac{1}{8}$  inches; adjustable tone-arm for playing all disc records; high-grade, silent, Starr-made motor; twelve-inch turn-table; speed control; automatic motor stop; tone regulator; nickel-plated hardware; one package steel needles; filing system.

The Style XIX Starr is an instrument you'll be proud to have on your floor. Not only has it the features and refinements now expected of the modern phonograph, but it possesses beauty and dignity throughout and is replete with that quality of workmanship which has made all products of Starr origin famous for half a century.

Silver Grain Spruce, "the music wood of centuries," forms the path for the perfect tone reproduction through the "Singing Throat" of the Starr Phonographs. All tones are produced with exact fidelity to the original. That is why we say "The difference is in the tone."

You'll marvel at the tone of Style XIX as well as its other features of obvious merit. Let us send you further information.



Silver-grain Spruce, "The Music Wood of Centuries," Makes "The Difference in the Tone" of the Starr Phonograph

## The Starr Piano Company

Established 1872

Richmond, Indiana

NEW YORK—CHICAGO—LOS ANGELES—BIRMINGHAM—DETROIT—CINCINNATI—CLEVELAND  
INDIANAPOLIS—BOSTON—JACKSONVILLE—LONDON, CANADA



# A NEW DANCE CRAZE STUMBLING

A FOX TROT ODDITY

"You can't go wrong  
With any FEIST song"

HEAR IT NOW

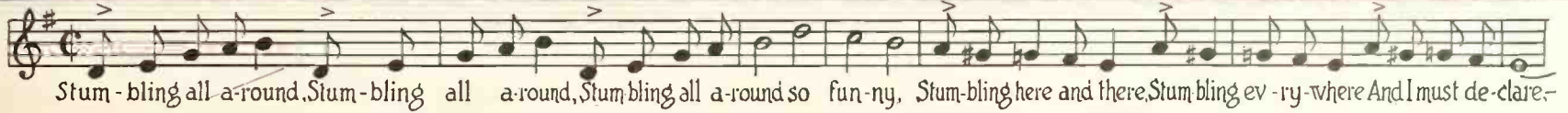

Stum-bling all a-round. Stum-bling all a-round, Stum-bling all a-round so fun-ny, Stum-bling here and there, Stum-bling ev-ry-where And I must de-clare-

## FORMS SWANSON SALES CO.

R. W. Moon General Manager of New Company—Will Merchandise Swanson Portable Phonograph—Offices Located in New York, Chicago and Los Angeles—All Central Points

R. W. Moon, general manager of the Swanson Sales Co., was a visitor to New York the past few weeks, making arrangements incidental to the merchandising of the Swanson portable phonograph, for which his company is the sole sales representative. Before leaving for his home

spring motor, and its general design provides for maximum compactness with a minimum of annoyance and inconvenience. Mr. Moon plans to merchandise the Swanson portable phonograph through jobbers and dealers and within the next few weeks will announce the names of the jobbers who have already been appointed.

The Swanson portable phonograph is not a newcomer in the industry, as it has been manufactured in Chicago for the past few years. Under Mr. Moon's direction, however, the factory facilities have been increased tremendously and arrangements have been made whereby the output will be sufficient to meet the demands of the trade.

At the present time the Swanson portable phonograph is being merchandised by a large number of the well-known talking machine dealers on the Pacific Coast, and among these is the Parmelee - Dohrmann Co., which maintains seven stores on the



How Parmelee-Dohrmann Co. Featured the Swanson

in Los Angeles Mr. Moon announced that the New York office of the Swanson Sales Co. will be located at 1133 Broadway. The company also maintains offices in Los Angeles and Chicago, Ill., and plans have been completed for an intensive sales campaign in behalf of the Swanson portable.

This portable, which weighs only fifteen and one-quarter pounds, has a number of distinctive features, including a wooden tone arm. It is equipped with a Heineman thirty-six double-

Coast. In its Los Angeles store the Parmelee-Dohrmann Co. recently featured the Swanson portable phonograph in an attractive window display and Mrs. H. P. Howard, manager of the talking machine department, states that this display was responsible for a large number of direct sales and an invaluable list of prospects.

## PLANS TO ADD RADIO

Canadian Concern Notifies Trade That It Has Two Sets Under Consideration

LONDON, ONT., July 8.—The following letter to the trade has been issued by the Starr Co. of Canada, Ltd.: "Following our policy of keeping fully abreast with the times, we now have options on two radio sets considered the best on the market to-day. These will be available for Starr dealers just as soon as we are satisfied in regard to the patent, plus the satisfactory results from these particular sets. Starr dealers, therefore, need not make arrangements outside of this company for their radio requirements. On the other hand, it is not our intention nor desire to place radios in the hands of Starr dealers until we are absolutely satisfied in connection with the patents laws, and also we wish to give the radio proposition time to find its proper level, that is, we have no intention of placing stock of radio part sets with Starr dealers and then have the equipment improved upon with stock remaining in the dealer's hands

"The two sets we have under consideration are undoubtedly the best offered to-day, and just as soon as we get one or two matters cleared up in regard to these Starr dealers will receive announcement from us."

The Whiteside Music Store, Colton, Cal., has been succeeded by Eckland's Music Store.

## NEW REPEAT-A-RECORD JOBBER

Rudolph Wurlitzer Co. Appointed Jobber for New Repeater—Important Deal Means a Wide Distribution for This Repeating Device

CINCINNATI, O., July 5.—P. E. Snell, of the Repeat-A-Record Co., of Los Angeles, manufacturer of the Repeat-A-Record, a new repeating device, was a visitor to this city recently and while here closed a very important deal with the Rudolph Wurlitzer Co., whereby this concern becomes a distributor for the Repeat-A-Record. Mr. Snell received the initial order and plans have been made for an extensive sales and publicity campaign in behalf of this repeater. The Rudolph Wurlitzer Co., with its various wholesale branches and many retail stores, is in a splendid position to give this new repeater an excellent sales representation, and the Repeat-A-Record Co. is co-operating with the Wurlitzer organization in every possible way.

Earl C. McNeil, 5711 Pasadena avenue, Los Angeles, Cal., is planning to enter the talking machine and musical instrument business.

## Main-Springs

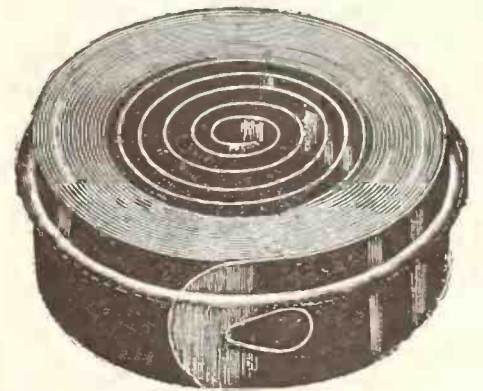

For any Phonograph Motor  
Best Tempered Steel

	Each
3/8 inch x 10 feet for all small motors.....	\$ .30
1/2 " x 10 " " " Pathe, Columbia, Heineman.....	.35
1 " x 10 " " " Columbia.....	.40
1 " x 11 " " " Columbia with hooks.....	.50
1 " x 13 " " " Victor, old style.....	.45
1 " x 15 " " " Victor, new style.....	.50
1 1/4 " x 18 " " " Victor, new or old style.....	.70
1 " x 12 " " " Heineman and Pathe.....	.45
1 " x 10 " " " Saal, Silvertone, Krasberg.....	.45
1 " x 13 " " " Saal, Silvertone, Brunswick.....	.50
1 " x 16 " " " Sonora, Brunswick, Saal.....	.60
1 3/16 " x 18 " " " Heineman and Pathe.....	.75
1 1/2 " x 25 " " " Edison Disc.....	1.50

### SAPPHIRES—GENUINE

Pathe, very loud tone, each 15c, 100 lots \$11.00.  
Edison Loud-tone, each 15c; in 100 lots, \$11.50.

### TONE-ARMS

The very best, loud and clear, throw-back.....\$4.50  
With large reproducer, very loud, Universal..... 4.00  
With smaller reproducer, but loud and clear..... 2.50

### PHONOGRAPH NEEDLES

We can give you best price on Brillantone, Magnedo, Wall-Kane, Tonofone, Nupoint, Gilt Edge, Incas and Velvetone Needles.

### ORDER RIGHT FROM THIS AD

Send for price list of other repair parts and motors.  
Terms—F. O. B. St. Louis, Mo. Send enough to cover postage or goods will be shipped by express.

The Val's Accessory House  
1000-1002 Pine St. St. Louis, Mo.

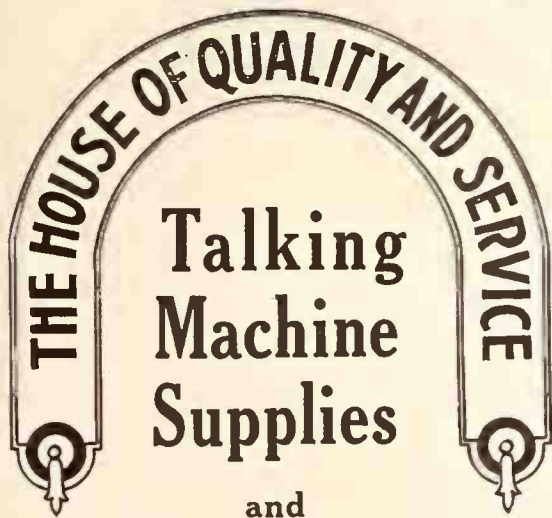

and  
Repair Parts

SAMUEL ESHBORN

65 Fifth Avenue  
New York



# M I L W A U K E E

*Decided Improvement in Trade—Portables in Favor—Badger's Effective Advertising Campaign—Victor Sales School in Fall*

MILWAUKEE, Wis., July 8.—As conditions improve in the Milwaukee industrial world a corresponding improvement is reflected in the talking machine trade. A better feeling seems to have developed within recent months and volume of sales for June, compared with the same month for the preceding year, shows a material increase.

#### A Message of Cheer

"Our records show that sales of talking machines this year are better than those of a year ago and nearly equal to the record season two years ago," declared Sam Goldsmith, of the Badger Talking Machine Co., Wisconsin distributor for the Victor Talking Machine Co., expressing the opinion held by most distributors and jobbers here. "We find that sales are increasing instead of falling off as the Summer season progresses. July and August, which had hitherto been considered dull months, will be, in all likelihood, listed among the banner months of the year if the trade continues as well as it started the Summer session in July.

"All factories in the city are working at capacity and 'Help Wanted' signs are seen in the industrial districts. The poorer class of people who had been compelled through lack of funds to postpone buying anything but strict necessities can now satisfy their tastes, possessing the necessary funds.

"We are selling the medium-grade machines at this period, mostly to the middle classes. The wealthier trade is not in the market for anything but portable talking machines for their Summer homes, vacation tours and camping trips. In the Fall, upon their return, the higher-grade stock will again show signs of activity. For the pres-

ent we are content to accept the large volume of trade in the lower-priced machines."

This condition and state of affairs was found to be the same in practically every distributing and jobbing house in the city visited by The Talking Machine World correspondent. Expensive stocks are inactive; medium grades are selling well.

#### Many Portable Models Sold

One of the features of the Summer-month sales is the unprecedented demand for portable talking machines. Jobbers declare that the demand for these machines has spread and that every music lover who is in a position to do so purchases a portable machine for his Summer outing. Excellent sales are reported in northern Wisconsin, in the lakes and parks district and in the upper peninsula of Michigan, the haven of vacationists.

Dealers in the Summer resort cities have had the forethought and experience to lay in large stocks of the portable machines. Several Milwaukee distributors of standard makes report emergency orders filled and others received from many of the dealers in the famous Wisconsin lakes and parks district who had sold their stocks earlier than the most optimistic had predicted.

#### Records Moving Apace

Sales of records are keeping pace with the Summer trade in talking machines. The average vacationist lays in a large stock of new records and goes on his Summer tour, returning in the Fall for newer releases. Jobbers are issuing booklets containing ideal "vacation libraries," lists of records suggested for the Summer camps that are assisting materially in record sales promotion.

Wisconsin, "The Playground of America," is an ideal field for portable talking machines and Summer records, and a canvass of Milwaukee distributors who supply this territory indicates that a goodly volume of trade is yet to be enjoyed during July and August.

The Phonograph Co. reports excellent sales in the New Edison, together with a corresponding trade in Summer dance hits and popular songs in the records. Consistent advertising is responsible to a great degree for the popularity of this line in the territory.

#### Grafonola Sales Booming

"The Columbia Grafonola sales for June easily surpassed those of the preceding month," said R. H. Walley, representing the line in the eastern half of Wisconsin. "Columbia machines still rank with the leaders in popular favor," he declared, resting for a moment to discuss market conditions with The Talking Machine World correspondent. "Sales to the country trade, usually the poorest buyers, have greatly improved, due to excellent crop reports and general all-around good feeling in the agricultural districts. City dealers have no difficulty in keeping their stocks in constant motion."

#### Sales Record for Sonora Portable

The leather-covered Sonora portable phonograph is establishing new records for the Summer, according to Fred E. Yahr, president and general manager of the Yahr & Lange Co., jobber for the Sonora in Wisconsin and northern Michigan. The portables are easily the features of the Summer, he declared. The Yahr & Lange Co. is running semi-weekly advertisements featuring the Sonora portable and records to stimulate and encourage the Summer sales.

#### A. G. Kunde Returning From Europe

Mr. and Mrs. A. G. Kunde sailed from London last week on their return from a three-month European tour. Mr. Kunde, formerly one of the prominent Columbia dealers in the city, now markets the Gennett records, with headquarters at 344 West Water street. He also handles the Starr phonographs. Upon his return to Milwau-

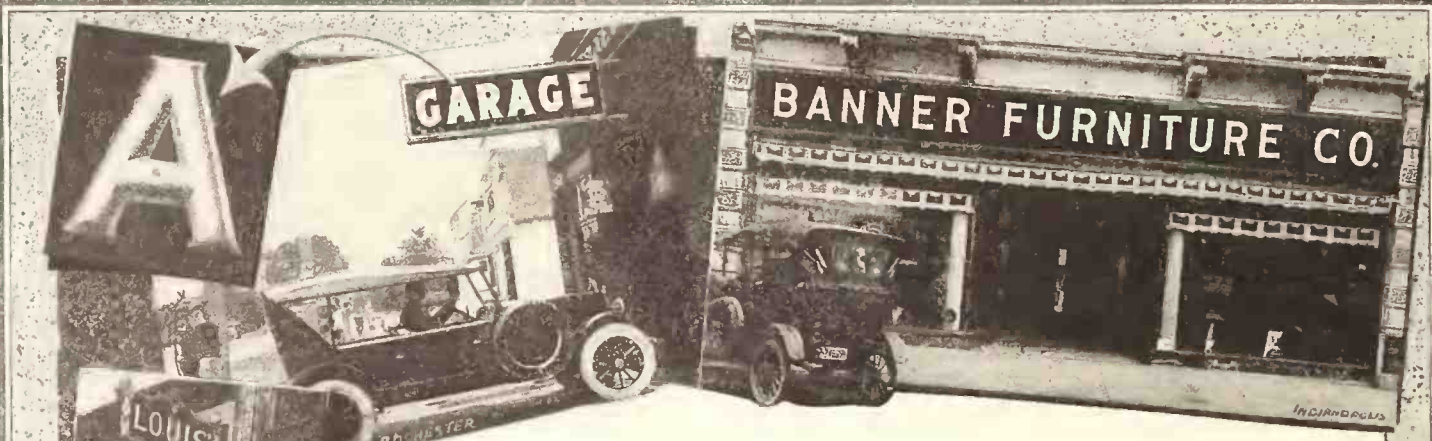

**Flexlume Signs—**  
*Advertising at Low Cost*

A Flexlume Electric Sign will tell your story to thousands at a cost of only a few cents a day. They are the kind with the raised, snow-white glass letters standing out from a dark background—perfect day signs as well as night signs. Flexlumes have greatest reading distance, lowest upkeep cost, most artistic designs.

*Let us send you a sketch showing a Flexlume to meet your particular needs.*

**FLEXLUME CORPORATION**  
36 KAIL STREET                      BUFFALO, N. Y.

*Flexlumes—Electric Signs Made Only by The Flexlume Corporation*



**"The Parade of The Wooden Soldiers" is one of the reasons why "Chauve Souris," the Russian Vaudeville Show, has taken New York by storm. Ray Miller and His Orchestra have woven this martial music in miniature into a fox-trot that won't let your feet behave. "Twas in the Month of May" from the same show is on the reverse. A-3628.**

**Columbia Graphophone Co.  
NEW YORK**



kee he plans the institution of an intensive advertising campaign. Billboards at vital points on the city's highways and the State trunk roads have been leased by him. A number of leaflets and "gem selection" pamphlets will be printed and large semi-weekly advertisements will be run in the local newspapers. Mr. Kunde, together with a number of other prominent jobbers and wholesalers, plans to start after Fall business early in August and will start his advertising campaign around that date. He intends to feature the Starr phonograph, particularly the new styles, and Gennett records in an effective way.

**Plans Victor Campaign**

Harry A. Goldsmith, secretary of the Badger Talking Machine Co., was found comfortably located in his new offices at 191-193 Fourth street busily engaged in mapping out another Summer advertising campaign. He has prepared a list of records, termed a "suggestion list," containing a few choice records, mostly classical and old favorites. It will be printed and distributed to dealers to be used as a sales stimulus. Past experience has shown that the little pamphlets have more than proved their worth.

"Business may be classed as pleasantly fair," said Mr. Goldsmith in reviewing the present market conditions. "Summer season, usually slack, will not be dull during this year's vacation period. People seem to have more money to spend this Summer than they did last year and are satisfying their tastes for music. The vacationist who can get away to country homes and camps is purchasing portable machines and a large stock of popular songs and dance hits to tide him over until his return. On the other hand, the urbanites who are doomed to remain in the city are seeking Victrolas to while away or dance away the warm Summer evenings.

"The outlook for Fall is surprisingly encouraging and we are sure that our hopes will not be blasted in wishing for an active Fall movement in records and machines. In preparation for Fall sales I am getting up a large number of advertisements to be set up, with a good layout, proper type balance, to be sent, together with all necessary cuts, to our country-town dealers, so that simultaneously with the launching of our campaign in the big cities the smaller towns will likewise be covered with Victor ads.

**To Open Victor Sales School**

"Early in the Fall we will open our Victor Sales School and all retailers and their clerks in Milwaukee, Wisconsin and upper Michigan are in-

vited to attend. One week of intensive training in sales promotion, under the supervision of Victor experts, will be given. We have not decided definitely the exact week that will be chosen for the training, but announcements will be sent out within the coming week to that effect. We expect a large number of out-of-town dealers to attend the sales school."

**Invents New Needle**

The necessity for using more than one style of needle to obtain different tones from the music of the phonograph will be eliminated when a new needle invented by George E. Bernecker, president of the Standard Accessory Corp., this city, comes into general use.

"In experimenting with phonograph needles," said Mr. Bernecker, "I found that the vibration causing the sound affected the surface of the needle only. The needle-point travels on the record along a spiral path, on the side of which there are little grooves. This travel causes vibration on the needle. Changing the shape of the

needle changes its vibration and the tone of the music produced.

"An idea struck me. Why not make a needle with an irregular profile and see what would happen? I tried it out. I took an ordinary standard needle and made a groove or indentation on one side of it. When I put it on the record with the grooved side toward the needle's track the music given out was low and soft. When the straight edge was turned in the music was loud. By rotating the needle to a point in between the music was reproduced in a tone of medium quality."

**Steady Demand for Brunswick**

The Brunswick-Balke-Collender Co.'s local branch, under the management of Thomas I. Kidd, reports that machines and records of the Brunswick make are holding their own with the leading standard instruments. Records are moving in a steady stream through the Milwaukee branch and market reports from Manager Kidd's offices are anything but pessimistic.

**NOW THE FLETCHER RECORD CO.**

Plant of Olympic Disc Record Corp. Purchased by Harry Pace and John Fletcher and Will Be Operated by a New Corporation

The plant of the Olympic Disc Record Corp., located at Meadow and Creek streets, Long Island City, according to an announcement, was recently purchased jointly by Harry Pace, of the Pace Phonograph Corp., and John Fletcher and has been reorganized as the Fletcher Record Co., Inc. The officers of the company are: John Fletcher, president, and Harry H. Pace, vice-president and treasurer. Mr. Fletcher has long been known in recording circles, having been one of the pioneers in that field. He was the organizer and head of the old Operaphone Co., Inc., which one time occupied the same plant, it later being taken over by the Olympic Disc Record Corp. on whose staff Mr. Fletcher was retained in executive capacity.

The Fletcher Record Co., Inc., has been operated, since the acquisition, exclusively for the production of Black Swan Records marketed by the Pace Phonograph Corp. It is understood that the plant is now running to capacity and the arrangement with the Pace Phonograph Corp. gives this latter company exceptional facilities, not only for quantity production, but for the rendering of unusual service, owing to the location of the plant.

Harry Pace, president of the Pace Phonograph Corp., in speaking of the development of his company, said: "We are now issuing ten numbers a month instead of three, on which basis this business was started. We do our own recording, plating, pressing, as well as printing of every description, in the above plant."

There is some likelihood that in the early Fall Mr. Fletcher will revive the pressing of the Olympic record.

The clerk who acts in a condescending manner toward the customer who asks to see some cheaper models is curtailing the firm's profits.

**OPENS OFFICES IN NEW YORK**

The Superior Phono Parts Co., 560 Grand street, Brooklyn, N. Y., recently opened up offices at 799 Broadway, New York City. The company distributes phonograph parts of all kinds, including main springs, tone arms and motors and has recently added radio parts to its line. It looks for an increased demand for its product in the early Fall.

**Sharpen the Fibre Needle**

Without removing it from the  
**Tone Arm of the Phonograph**

*It's 5 years ahead of the times*

**CONVENIENT**



**FAST SELLER**

**GOOD PROFITS**

**MECHANICALLY RIGHT**

*Very Simple*

**LIDSEEN  
FIBRE NEEDLE  
CUTTER**

**LIDSEEN PRODUCTS**

832-840 So. Central Ave. CHICAGO

**RECORDING  
FOR THE TRADE**

We have a modern well-equipped laboratory with facilities for producing the highest grade recordings. *We Solicit Your Business*

**Manhattan Recording Laboratories**  
48 West 39th St. New York



*"Genius is but the infinite capacity for taking pains"*

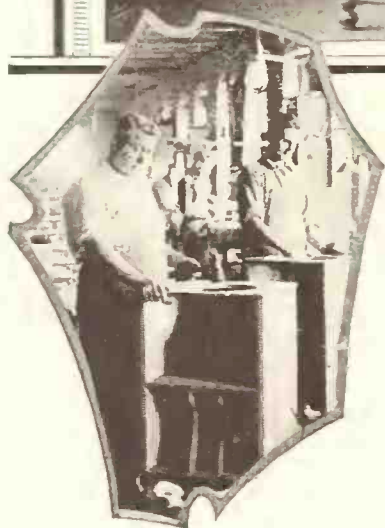
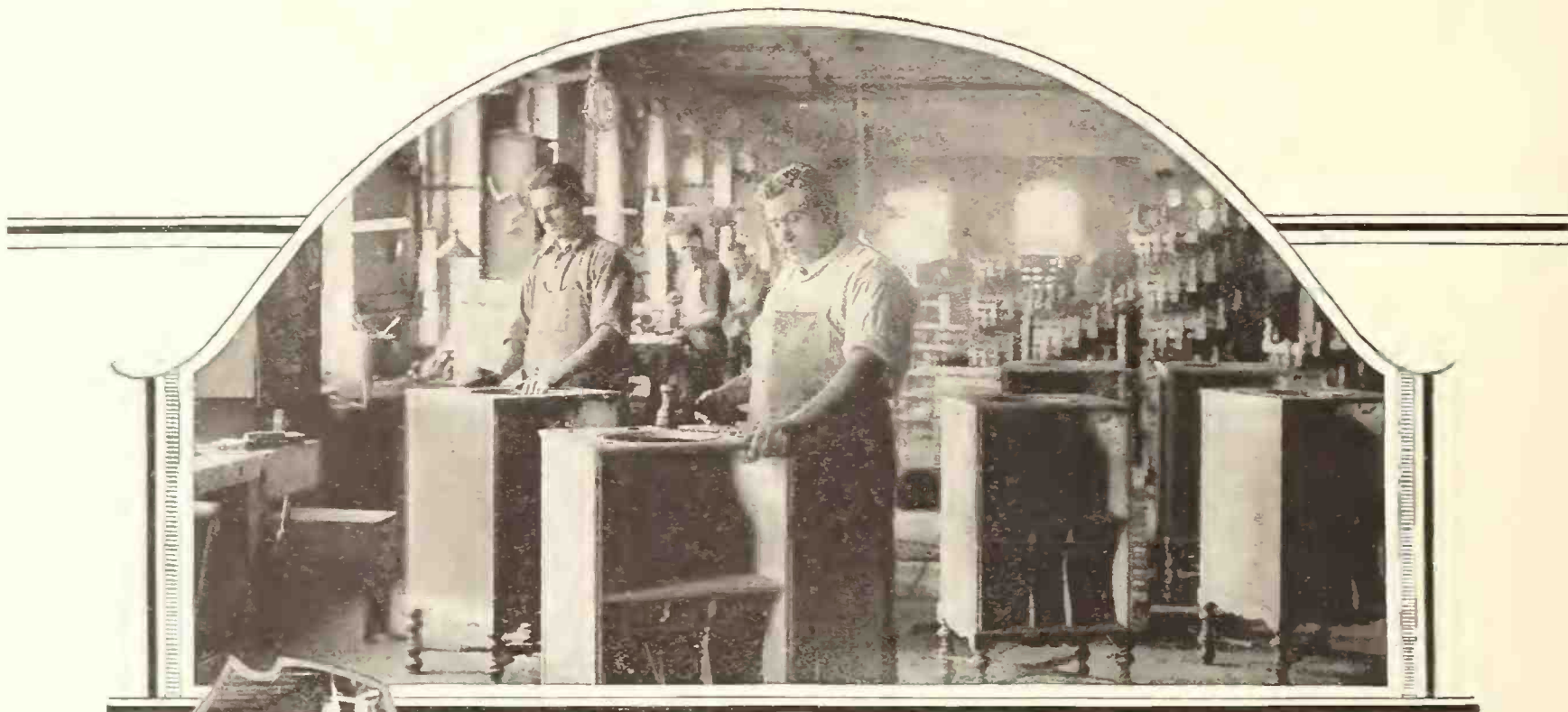

## *Where Father Passes on to Son His Talent and His Craft*

### *A Typical Story of Cheney Workers*

Klass van Bolhause was known for forty years in Groningen, Holland, as a cabinet maker *par excellence*. Having brought his son Berend up in the craft, he passed his business on to him when he died at the age of seventy. Berend for thirty years maintained the name and fame of the family. His son, John van Bolhause, in turn tutored in the art, entered the business at seventeen, and ten years later, in 1913, sought wider opportunities in America. Today, with his fellow craftsmen, he is building into Cheney cabinets the character and beauty that have helped to make The Cheney known as the "Master Instrument."

Poets, it is said, are born—not made. So it is with every art where genius lends wizardry to the fingers of skill.

In the Cheney factories, located in the heart of one of the greatest furniture building centers in the world, father and son stand side by side putting into Cheney cabinets all of the enthusiasm of youth and the talent of age.

Cheney cabinets excel because Cheney workmen excel. They are artists and craftsmen just as surely as the guild workers of old. Scores of Cheney workmen are scions of a long line of cabinet makers and are devoting their lives to making furniture worthy of their names. Their rich heritage of genius is being preserved for future generations—they are building it into the beautiful cabinets of The Cheney.

THE CHENEY TALKING MACHINE COMPANY  
CHICAGO



# The CHENEY

THE MASTER INSTRUMENT

*"The Longer You Play It, the Sweeter It Grows"*



# BUFFALO

*Victor Dealers Come Together  
at Annual Outing—Business  
Improving—Trade Activities*

BUFFALO, N. Y., July 8.—The annual outing of the Victor Dealers' Association of Western New York was held at the Automobile Club at Clarence, N. Y., on June 28, and was one of the most enjoyable in the history of the organization.

Meeting at Elmwood avenue and West Utica street, at noon, one hundred dealers, salespeople and members of their families motored to Clarence, where the afternoon and evening were spent. A ball game between the Coo Coos and the Kicky Koos was the first event of the day, the Kicky Koos winning, 13 to 9. Julius Szabo, of Bieda Bros., won undying fame by hitting a home run, while John Wills, of the C. N. Andrews wholesale store, drove out a three-bagger which cleaned the bases.

A program of games, races and athletic events was held and provided thrills and entertainment in abundance. Winners of the contests for ladies were: 50-yard race for lightweights, Miss Ruth Shirk; 50-yard race for heavyweights, Mrs. J. Kibler; baseball throw, Mrs. C. Wright; broad jump, Mrs. H. Childs; balloon race, Miss Isabelle Berryman.

In the men's contests the winners were: 50-yard race for lightweights, H. A. Clark; 50-yard race for heavyweights, Hal F. Clark; wheelbarrow race, Wright and Bensching; broad jump, Joseph Quirk; tug of war, Melzer team.

Dinner was served to ninety-three guests at 7 o'clock. Speechmaking was barred, it was announced by Acting President B. E. Neal. At the conclusion of the banquet dancing was enjoyed until a late hour. Most of the stores of Western New York were closed in honor of the event.

C. E. Siegesmund, chairman of the committee on arrangements, received congratulations for the splendid manner in which the outing was conducted and for the general excellence of the program. Prizes of real value were obtained and awarded to the winners in each event.

### General Business Improving

General business conditions among the Buffalo and western New York trade are showing a gradual improvement, although June sales were not up to the expectations of many dealers. The outstanding feature of the present condition is the optimism which is held by dealers. The retailers are practically unanimous in their conviction that early Fall will see the return of normal business in the talking machine world.

Sales now are running large to portables and other models which are in general use in camps and resorts. Record demand is seasonal, with emphasis on the dance and lighter numbers.

Columbia dealers in this territory profiting by

the intensive advertising campaign report June an excellent month in volume of sales. Dealers who conducted individual campaigns in connection with the national advertising are more than pleased with the results obtained.

There is unusual interest among Columbia dealers in the release of the new Columbia portable. Lew Berk, songwriter and publisher and proprietor of the Song and Gift Shop, of Rochester, has just concluded a successful sale of the Columbia "Gallagher and Shean" record. A unique window display helped increase the volume of sales to near record proportions.

### New Victor Dealer in Warsaw

C. N. Andrews, Victor wholesaler, has added another live account to the growing list of retailers which he is serving. The Ballantine Hardware Co., of Warsaw, N. Y., has opened a talking machine department. This firm takes over the franchise of the J. C. Hoffstetter Co., whose business house was recently destroyed by fire. The Hoffstetter company will not resume business, it is understood.

As announced exclusively in last month's World, Mr. Andrews has been very fortunate in adding to his force C. E. Siegesmund, former president of the Talking Machine Dealers' Association of Buffalo. Mr. Siegesmund recently retired from the retail branch of the trade.

### Death of Lawrence F. Lewis

Regret was expressed here at the death of Lawrence F. Lewis in the DeGraff Memorial Hospital, at North Tonawanda. For several years Mr. Lewis had been working on an invention which, if completed, would have been a great step forward in the production and operation of automatic musical instruments, it is believed. The device upon which he was at work consists of a number of strong magnets, and is intended to replace motors in talking machines and other instruments. It is understood Mr. Lewis brought the device so near perfection that its completion is practically assured, despite his death.

### Benj. Neal Honored by University

Benjamin E. Neal, president and treasurer of Neal, Clark & Neal, and active head of one of Buffalo's largest talking machine and record stores, has just been elected an alumni trustee of Syracuse University. Mr. Neal defeated William J. Harvie, of Auburn, for this honor, which has seldom been conferred on any save persons residing in the immediate vicinity of Syracuse. A spirited campaign preceded the election.

### The Columbia at Chautauqua

Some exceptionally good work was done at the convention of the American Federation of Women's Clubs at Chautauqua Lake, N. Y., by the educational department representatives of the Columbia Co. Aided by several assistants, W. A. Willson gave a number of demonstrations with Grafonolas, special attention being given to the school outfit with pushmobile.

Duci di Kerekjarto, Columbia artist, visited a number of dealers here during a recent engagement in Buffalo. He was accompanied by M. H. Batz, city sales representative. Mr. Kerek-

jarto's records are most popular in the Buffalo and, in fact, throughout this territory.

Recent visitors at the Buffalo Columbia branch include J. W. Besch, Gowanda; S. Saeli, Jamestown; Robert Mann, Warsaw; F. W. Bolender, Cuba; G. F. Schafer, Batavia; Mrs. J. Cona, Rochester, and Mrs. M. Reickhoff, Niagara Falls.

### Work Started on New Factory

Ground has been broken for the new factory of the Artizan Factories, Inc., at North Tonawanda. Among the products of the new firm will be talking machines, it is understood; also office furniture and interior woodwork.

### Recent Change in Jamestown

The newly formed Walter Andrews Piano Co. has purchased the stock and business of the Goranson Music House, at 101 East Third street, Jamestown, and will occupy the quarters of the latter store. The new company, of which Walter Andrews is president and treasurer, is having a complete new talking machine department installed and will handle several makes of instruments and records.

### Two New Departments

Two new talking machine departments were opened here in June, that in the new Kurtzmann retail store in the Pierce Building and that in the new store of J. N. Adam & Co. in Washington street. Both are attractive and are notable additions to Buffalo's beautiful stores.

## INTRODUCES NEW REPEATER

**Repeat-A-Record Now Ready for Trade—Will Be Merchandised Through Jobbers and Dealers—Has Various Distinctive Features**

LOS ANGELES, CAL., July 3.—The Repeat-A-Record Co., of this city, has just completed plans for the manufacturing and merchandising of the Repeat-A-Record, a new type of record repeater that embodies several distinctive features. In a circular recently issued the company calls attention to the following details: "Bevel-edge, which conforms to the arc made by the needle while traversing the record; adjustable rubber slide, adjustable to all widths of music on ten-inch records, prevents damage by returning needle; trussed graduated grooves guide the needle, preventing a lateral motion with no injury to the sound box; a rubber wheel prevents surface noise and scratching.

The Repeat-A-Record, which is made of steel, case hardened and hard nicked, will retail at \$1.50, and the company plans to merchandise its product through jobbers and dealers. Jobbing territory is now being allotted and an aggressive sales campaign has already started.

## KRUCK PIANO CO. CHARTERED

The Kruck Piano Co., of Philadelphia, Pa., has been granted a charter of incorporation under the laws of the State of Delaware to deal in pianos and talking machines. The concern is capitalized at \$200,000.

## The Madison

**—ACKNOWLEDGED THE BEST VALUE PORTABLE MACHINE IN THE MARKET TODAY**



Size 13" wide—12" deep—7½" high

*Dealers Delighted with the MADISON. REPEAT ORDERS Prove Its Worth*

## Special Release of Imported Record

*Symphony Concert Record No. 2824*

10 Inch

**Violin Solo**

{ Souvenir de Drdla  
Kubelik's Serenade }

**50c.**  
RETAIL

and many other numbers. Write for complete list and dealer prices.

*An Attractive Jobbers Proposition—Write for Territories*

**Madison Music Co., 114 E. 28th St., New York, N. Y.**



## FEDERAL CONTROL OF TRADE ASSOCIATIONS PROPOSED

Bill Recently Introduced in United States Senate by Senator Edge Has Aroused Considerable Interest in the Music Trade and Other Industries—Follows Secretary Hoover's Recent Investigation

Considerable interest is being shown by the various trade associations in the music industry in a bill recently introduced in the Senate by Senator Edge, of New Jersey, Senate Bill No. 3385, which provides for Federal control of trade associations by forcing those organizations to file with the Federal Trade Commission the names and addresses of their members, officers, directors and committees, copies of their by-laws, the minutes of all meetings and copies of all resolutions and agreements entered into.

The bill also provides that the Commission shall be supplied with copies of all statistics gathered by the associations or for its benefit, and that the Commission may give publicity to such statistics if considered of interest to the public. Under the measure it will also be necessary for trade associations to notify the Commission seven days in advance of all meetings whether general or of committees.

Trade associations and executives generally see in the bill a real menace and a direct effort to increase Federal control of general business, which has already reached a point where it proves a distinct hindrance in many instances. It is felt that to comply with the requirements of the new law, should it be passed, would interfere materially with the activities and usefulness of various trade bodies, and it is probable that the opposition will make itself felt in no uncertain way when the bill comes up for consideration.

In addition to the Edge Bill there has been introduced in Congress what is known as Joint Resolution No. 188, which provides for the "creating of a committee to investigate existing conditions of industry and commerce in the United States for the purpose of recommending to Congress legislation defining the rights and limitations of co-operative organizations as distinguished from illicit combinations in restraint of trade."

The Edge Bill and the Joint Resolution have developed out of the recent investigation of certain trade associations which engage in practices alleged to be illegal and in violation of the Anti-Trust laws. Such associations are not in any sense representative of trade bodies as a whole, and it is felt that it is unjust to attack and penalize all trade bodies indiscriminately for the crimes of a few.

The Government, through Secretary Hoover, of the Department of Commerce, has for some time past been engaged in studying the trade associations and their work, ostensibly for the purpose of developing closer co-operation between the Government and business interests through the medium of trade bodies. It is felt that legislation such as that proposed would serve to nullify any good work that has been accomplished at the meetings between Government officials and trade association executives.

### AEOLIAN MUSIC FOR THE SHRINERS

Steinway Duo-Art Piano and Vocalion Phonograph on Special Train Which Carried Kismet Temple Nobles to the Pacific Coast

When the Nobles of Kismet Temple, of Brooklyn, set out on the annual pilgrimage, this time to the Pacific Coast, they engaged a special train on the Pennsylvania Railroad. Sam Reider, general passenger representative of the Pennsylvania Railroad, who was in personal charge of the train, had the comfort of the Nobles in mind to such an extent that he arranged for the installation on the train of a Steinway Duo-Art piano and a Vocalion phonograph, with a liberal supply of Red records. The music from the instrument served to help pass many a long hour on the trip through the South, going, and through the Northwest and Canada, returning.

## NEW GRAFONOLA HEADQUARTERS

Bungalow Grafonola Shoppe Opens for Business in Duluth, Minn.—Well-equipped Store

DULUTH, MINN., June 26.—Beautiful and unique is the description accorded the Bungalow Grafonola Shoppe, 101 West First street, just opened for business. Duluth has no other spot like it nor any that approaches it in its particular field.



Interior of Bungalow Grafonola Shoppe. Two Duluth young men, A. Edelson and Harry Segal, are owners of the business, in which Columbia Grafonolas and records are handled exclusively.

As one enters there is noted the actual replica of a bungalow, with the doors leading to seven sound-proof, glass-enclosed rooms, where selection of instrument or records may be made privately in comfort. The bungalow represents the utmost in originality and beauty and is one of First street's most notable points of attraction.

### NO SUMMER SLUMP EVIDENT

Demand for Banner Records Suffers No Curtailment With the Coming of the Summer Months, According to Sol. Kronberg, of Plaza Co.

Sol Kronberg, manager of the Banner record division of the Plaza Music Co., New York City, recently stated that evidently Summer business on the popular-priced Banner records seems to show no curtailment. He credited this situation to the fact that every effort has been made to supply the dealer with the biggest successes in quantities prior to the height of the demand, thus allowing the retailer ample time to meet all demands.

"We are keeping the Banner quality up to the highest standard and this in every detail, including the musical recording, workmanship and the material used. Our service to the dealer not only means an immediate shipment of orders, but liberal supplies of very attractive window display material, catalogs, mats for newspaper advertising and the assistance of our advertising department. The agencies for Banner records, arranged for in different parts of the country, are showing substantial increases from month to month."

### NEW VICTOR ENVELOPE STUFFERS

Selected Records Advertised in Convenient Way for the Use of the Dealer

The Victor Talking Machine Co. has arranged to issue monthly domestic and foreign record supplements in attractive envelope stuffers featuring selected groups of records and intended for the use of dealers in all letters they send out. The first of the stuffers was issued with the July supplements and lists seven records, including Bartlett's "A Dream," the Berceuse from "Joscelyn," "Love's Old Sweet Song," "There Is Somebody Waiting for Me," and others.

### COMMERCIAL REALIZATION CORP.

The Commercial Realization Corp., South La Salle street, Chicago, Ill., has been granted a charter of incorporation to deal in musical instruments, with a capital of \$2,500. Incorporators are: Henry J. Brandt, W. R. Swisler and A. L. Rittenberg.

The  
*Modernolette*

A REAL  
Talking  
Machine

in  
Portable Form



Retail Price

Wax Finish  
Case  
\$35.00

Leatherette  
Covered Case  
\$40.00

MODERNOLA CO., Johnstown, Pa.

The Modernola Sales Co., Inc.

No. 929 Broadway

New York City



## A Real Musical Instrument for Children

**Cabinet**—Durable Diamond construction throughout. Made from selected veneers and hardwoods. Built with infinite care by experienced cabinet makers. Height, 24 inches; width, 14 inches; length, 28 inches.

**Finish**—Enameled in Gray, Blue and Ivory. Washable finish. Blue or old rose silk grille.

**Motor**—Heineman motor — cut gears—cast frame—fully guaranteed—removable motor board.

**Tonearm**—Die cast—nickel plated — Artois reproducer.

**Turntable** — Special 9-inch felt faced—plays all records, 10-inch or smaller. Particularly adapted to all children's records, including Bubble Books.

List Price, \$25.00 each.  
Six machines or over,  
\$15.00 each  
Less than six machines,  
\$16.50 each

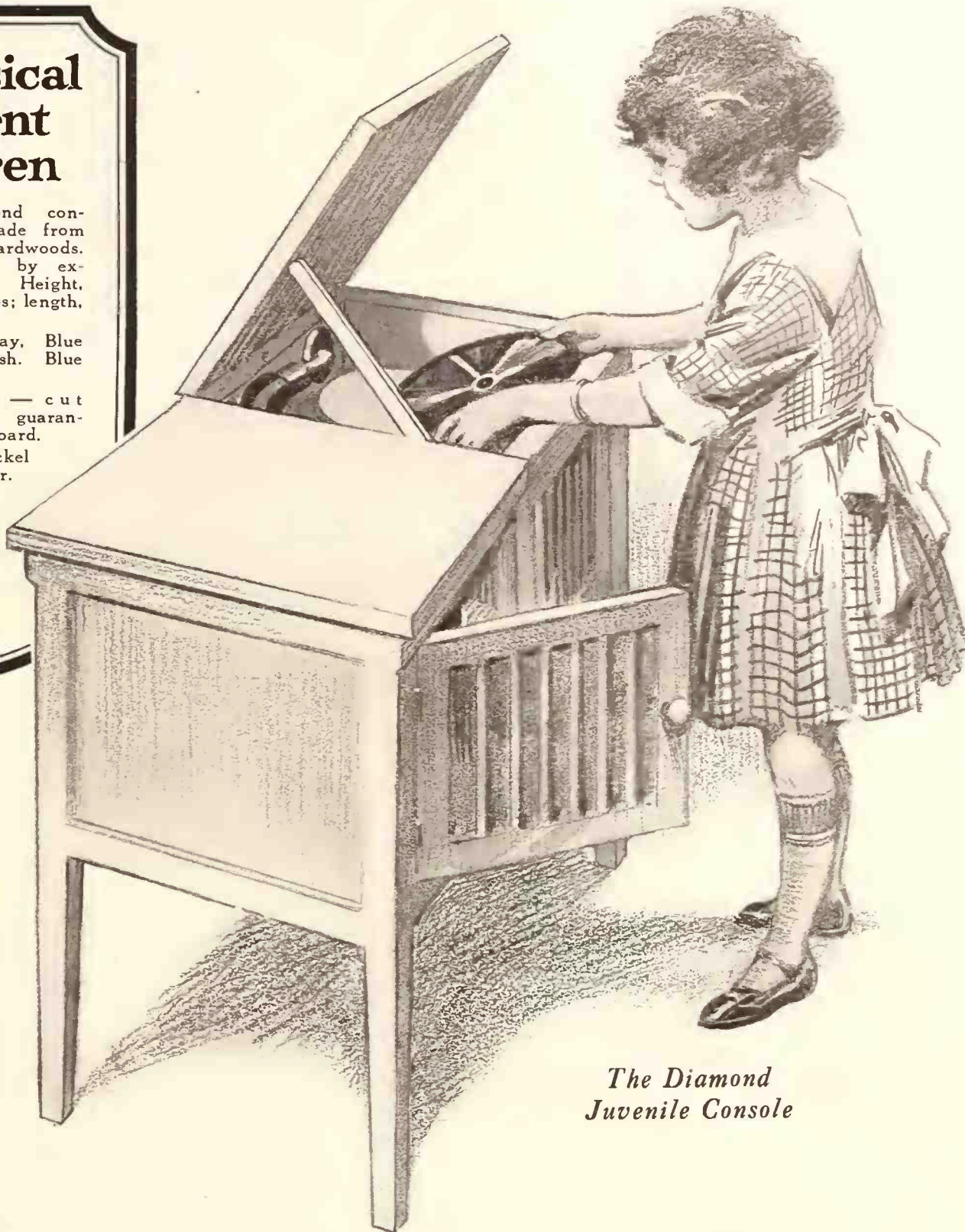

*The Diamond Juvenile Console*

### Diamond Juvenile Furniture

Six pieces—4 chairs, table and hat rack. Juvenile proportions. Durably made. Beautifully enameled and decorated. Makes perfect juvenile booth when installed with the Diamond Console. Fine for window display.

**Six Pieces — \$17.50**  
F.O.B. Oswego, N. Y.

## New Profits from Three Directions

The Diamond Juvenile Console is giving new impetus to the entire retail talking machine industry.

It is the first practical talking machine for children. Appeals instantly to youngsters. Sells itself to parents. Profit is generous and turnover surprising.

Creates a real child's department. Brings youngsters into the store. Stimulates buying of juvenile records.

Through children it brings parents into the store more frequently. Thus it increases the sales of regular records.

Dealers say the Diamond Console is the greatest contribution to the business in years. Write for full particulars.

### The Diamond Products Corporation

*Executive Offices and Showrooms:*

25 West 43rd Street, New York      Factories: Oswego, N. Y.



**NEW REGAL SALES MANAGER**

Harry G. Neu Now Sales Manager of Regal Record Co.—Aggressive Sales Campaign Under Way—Company Announces That It Will Market Through Dealers Exclusively

Harry G. Neu, formerly sales manager of the Emerson Phonograph Co., has been appointed



Harry G. Neu

sales manager of the Regal Record Co., which was recently incorporated under the laws of the State of New York for the purpose of manufacturing Regal records. Mr. Neu, who is well known in wholesale talking machine circles, has been identified with the industry for a number of years. Prior to becoming sales manager of the Emerson Phonograph Co. he was sales manager of the Emerson Record Sales Co., New York, where he acquired an intimate knowledge

of the dealers' requirements for developing a profitable record business.

According to the plans of the Regal Record Co., new lists will be issued monthly and the records will retail at fifty cents as heretofore. Popular and standard numbers will be recorded, and the merchandising plan calls for distribution through the dealers exclusively. Mr. Neu has organized an efficient sales staff and an aggressive campaign has already been inaugurated in behalf of Regal records.

**DENVER EDISON DEALERS ORGANIZE**

Colorado Division Forms Association With W. Le Roy Larson as President—Knight-Campbell and Wells Co. in Radio—Other News

DENVER, COLO., July 5.—An Edison Dealers' Association was launched at a meeting of dealers from the Colorado division held in the Edison department of the Denver Dry Goods Co. recently. Dealers from Colorado, Wyoming, New Mexico, Kansas and Nebraska were present. W. LeRoy Larson, of Sidney, Neb., was elected president and Carl Schultz, of Denver, secretary. The organization is formed for an exchange of merchandising ideas and problems that confront Edison dealers. The plan is to meet semi-annually. In the Association are eighty-five dealers. The society was largely formed at the suggestion of Norman D. Tharp, buyer of the Edison department, wholesale and retail, of the Denver Dry Goods Co.

June 21 in Denver found a temperature of ninety-eight. Humanity sweltered. The Darrow Music Co. took this psychological moment to feature an old beer keg used for the mounting of a phonograph. Two little doors cut in the side of the keg, when opened, revealed the interior workings of the talking machine. The tune "How Dry I Am!" coming from the keg hailed the passer-by, who looked on thirstily, wishing he could have such music with the good old stein

of beer. The idea was not entirely new, but made quite a hit locally.

C. G. Campbell, president, and W. W. Bradfield, treasurer of the Knight-Campbell Co., have returned from the East, where they attended the various trade conventions in New York and Atlantic City.

At least two Denver music houses have gotten into the radio game. Others contemplate giving out programs later. Each Tuesday night the Knight-Campbell Music Co. puts on a radio concert. Many artists of prominence have been heard under the auspices of this company and Tuesday is known as Knight-Campbell night. Alexander Saslavsky, violinist, and Alfred De Voto, pianist, with their wives, are vacationing in Denver and on June 27 the Knight-Campbell Co. prevailed upon these two musicians to broadcast for the first time in their history a concert for the benefit of radio fans. The Charles E. Wells Music Co. also furnishes programs for radio fans during the week, special artists giving piano and vocal numbers.

A judgment for \$250 was given in favor of Irving Berlin, Inc., New York, in its suit against the Edelweiss Café, of Denver, in Federal Court here. Berlin says the café orchestra had played his copyrighted song, "My Mammy," without paying royalty. Three other suits by Berlin against the café, involving other popular songs, were dismissed.

**INVENTS NEW TYPE OF AEROPLANE**

WASHINGTON, D. C., July 7.—Harry A. Berliner, son of Emile Berliner, president of the Berliner Gram-O-Phone Co.; Ltd., of this city, has invented a flying machine that will rise from the ground without the necessary forward run of the ordinary aeroplane. A number of difficulties remain to be overcome, but the progress of the invention is being watched with interest by Government officials.



Showing Reproducer of Jewel Needle Equipment Turned Up to Change Needle; Also Position When Not in Use



Showing Reproducer of Jewel Needle Equipment in Position for Playing Vertical Cut Records on Edison Phonograph



Showing Reproducer of Jewel Needle Equipment in Position for Playing Lateral Cut Records on Edison Phonograph



Showing Back View of Jewel Needle Equipment in Position for Playing Lateral Cut Records on Edison Phonograph

**JEWEL Needle Equipment for the NEW EDISON**  
**See Our Exhibit**  
**PAGEANT OF PROGRESS**  
**EXPOSITION**  
**CHICAGO, ILL.**  
**Booth 13, Section A**

**NOT**  
 Just Another Equipment  
**BUT**

a distinct improvement in  
 Tone Reproduction as well as  
 in Mechanical Construction  
 and Finish.

Send for descriptive circular  
 which contains "HINTS RE-  
 GARDING THE CARE OF A  
 PHONOGRAPH."

If your jobber does not handle,  
 write us.

Price the same. Liberal dis-  
 count to dealers.

**GUARANTEED IN EVERY  
 WAY.**

**MONEY BACK IF NOT  
 SATISFIED.**

We handle highest grade  
 Jewel Point Needles.

Needle **CENTERS** on all records.

Straight air-tight construction and absence of  
 movable joints insure perfect reproduction and  
 great volume.

Pivoted ball-joint insures perfect reproduction and  
 freedom of movement both vertically and hori-  
 zontally.

Weight is the lightest that can produce perfect  
 results, thus saving the record, and permitting a  
 freedom and sweetness of tone considered impos-  
 sible.

Indestructible **NOM-Y-KA** diaphragms do not  
 blast, crack, split or warp, and are the greatest  
 development in phonographic sound reproduction  
 in years.

Plays all types of records. Operates the same as  
 the "EDISON" with the LEVER.

No adjustments necessary when changing from  
 lateral to vertical cut records. Stop prevents  
 swinging to the right.

Needle scratch almost entirely removed.

Turning back of Reproducer permits of easy  
 access to needle socket and saves records from  
 unnecessary scratching.

Is the **ONLY** equipment that plays vertical cut  
 records in the proper "EDISON" position with  
 the Reproducer turned **FACE DOWN** to the  
 record, giving it a floating action.

**JEWEL PHONOPARTS COMPANY**

**154 W. Whiting St., Chicago**





The Lyradion Console

Combination radio and phonograph. An attractive cabinet completely housing all instruments, batteries, etc. Wired for Westinghouse "set" or complete with Lyradion 5 stage non-regenerative set.

## Radio and phonograph combined in the LYRADION —your customers will prefer this line

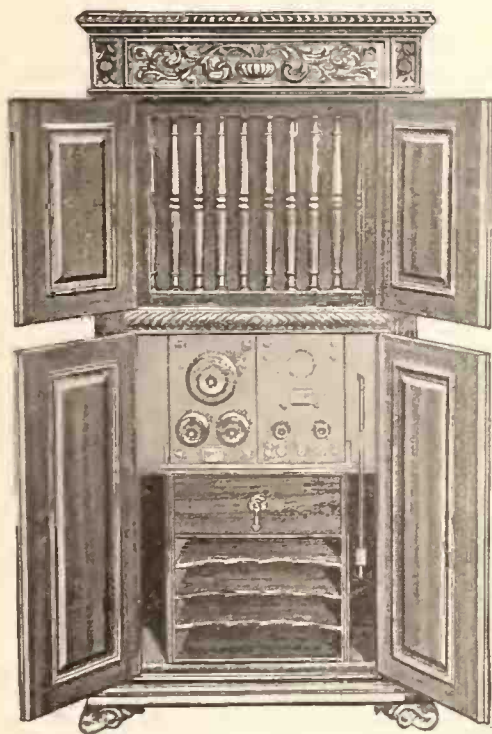

Lyradion Italian Renaissance

Combination radio and phonograph. A beautiful hand carved cabinet in polychrome finish for large homes and clubs. Wired for Westinghouse "set" or complete with Lyradion 5 stage non-regenerative set. All instruments and batteries completely housed.

Radio enthusiasts are expressing their preference for the Lyradion line of attractively housed radio sets in no uncertain terms. While the lady of the house has tolerated the old method of placing batteries and sets on the library table and floors as a matter of necessity in the past, she is now demanding the attractive Lyradion combination radio and phonograph completely housing instruments and batteries and offering dual and perpetual entertainment features. Besides these attractive cabinets harmonize with the furnishings of the modest, as well as the most luxurious home surroundings.

The Lyradion instruments do not stop at presenting radio in its highest form. They make possible the perpetuating of popular broadcasted selections by means of phonograph records and thus provide a source of year around entertainment.

The wonderful Seabrook amplifying horn used on all models is responsible for the remarkable reproducing qualities of Lyradion instruments. This horn employs entirely new principles of sound reproduction which are fully protected by basic U. S. patents.

Lyradion cabinets can be furnished wired complete for Westinghouse 2 stage R. C. sets or with Lyradion 5 stage non-regenerative receiving set.

To the dealer or jobber who desires to make the most of radio, the Lyradion line offers unusual opportunities for volume sales and quick turnover. Every owner of a Westinghouse set is a prospect for a Lyradion cabinet. Those who have not purchased radio sets are prospects for a cabinet with Lyradion set.

Territory is being rapidly allotted—dealers or jobbers should write or wire immediately for proposition.



Lyradion Model A, B & C

Radio only. Permanently wired to completely house a Westinghouse "set" or complete with Lyradion non-regenerative set.

# Lyradion Sales & Engineering Co.

which is Plant No. 5 of the Dodge Mfg. Co.

Mishawaka, Indiana

KENYON W. MIX, Director



# TOLEDO

## Energetic Sales Efforts Result in Better Business—Opening of New Stores—The Month's News

TOLEDO, O., July 3.—Talking machine merchants are putting their shoulders to the wheel and are securing a consistent volume of Summer business. The old bogey that the warm months are just naturally dull and that customers cannot be coaxed into the store has been routed and the gospel of hard work, little play and much push is being substituted.

Dealers have experienced a nominal revival in trade and the odor of victory is in their nostrils. In most stores advertising and sales campaigns have been launched recently or are being continued unabated—often with a new twist or unusual angle—destined to interest the most elusive buyer. New approaches are constantly being invented with the result that the reward justified the effort.

Charles H. Womeldorff, general manager of the Toledo Talking Machine Co., is highly enthusiastic over the convention of the Victor jobbers at Atlantic City. He states this year's gathering easily ranks as the most helpful and beneficial of any yet held.

### Early Ordering Urged

Dealers are being urged to place orders now for Victrolas to be delivered in thirty or sixty days, else it will be an impossible task to supply the demand which is sure to come before many moons. A few retailers have realized this and are placing orders, but by far the greater number are still watching and waiting. These, it is feared, will lose many sales because of a shortage of stock and unpreparedness to meet conditions which are steadily growing better.

### Larger Quarters the Rule

Summer resort dealers at Petosky, Bay View, Mackinaw and other popular northern Michigan watering places are reporting an awakening in the demand for talking machines and supplies. As a result orders are being booked more freely. The outlook is for a prosperous season's trade, according to W. B. Gannon, Toledo Talking Machine Co., representative for Michigan. Several Detroit clients of this company are planning to move into new quarters at an early date, among them: The Markowitz & Zuroff Music Co., Hastings street, which will move into a larger and finer

location directly opposite its present store; the Henry S. Doran Co., which moves to a new shop on Washington street, and the Goldberg Phonograph Co., which will likewise occupy new quarters.

Further, the formal opening of the new three-story store of R. D. Malcolm, Kearsly street, Flint, Mich., was an event of the middle of June. This was not only attended by patrons and friends, but by many persons from outside the city. The store is one of the most complete and convenient in every way to be found anywhere.

### Handsome New Toledo Store

Whitney, Blaine & Wildermuth Co., Toledo, now occupies the new upstairs store at 620 and 622 Adams street. This is one of the busy downtown thoroughfares. The store interior is decorated in fawn and mahogany. The demonstration booths are old ivory and are composed of French door designs, thus making each light and very attractive. A feature worthy of special mention is the arrangement of the booth interior. A settee or wicker chair is placed at a point back from the door and the machine for demonstrating purposes is just inside the door. Therefore, when a customer enters the room and is seated it is never necessary to pass in front of her or to apologize for discourtesies. The booths are constructed for quick, efficient service and all waste motion has been eliminated. Then, too, each room is provided with a perfect ventilation system. Record racks are finished in old ivory and are so arranged that a customer may be served in a jiffy. Miss M. Plotkin is in charge of the department. A formal public opening will be held in the near future, according to Henry Wildermuth, treasurer of the company.

### Portables in Demand

At the LaSalle & Koch Co., according to R. O. Danforth, manager of the Victrola Shop, a steady increase in sales is being registered. June is showing a substantial growth over last June. Portables are in brisk demand for canoe and cottage use. Large machines are likewise selling well, more than at any time within the past two Summers.

### Some Live Publicity

Grubbs Music Shoppe is exploiting current hits in an unusual manner. At the LaBounty Lakeside Ballroom, the La Tabernilla, Toledo Beach, Walbridge Park and other nearby resorts neatly painted cards displayed in prominent places state, "All numbers played in this hall are on records and sheet music at Grubbs Music Shoppe."

In addition to this Grubbs is distributing a total of 60,000 concert programs for the various municipi-

pal outdoor band concerts. Each program lists one or two hits as a part of the program being rendered, and endeavors to couple the number with records sold at the store. In this manner the Shoppe, the concert and the selection are brought together and each shares in the publicity of the other. The plan has been instrumental in bringing many new faces into the store.

Rae & Maxwell have evolved a novel method of marketing portables that have been used. A sign such as this has been placed in a large display window, "Don't take your good machine to the cottage, come in and rent a small one from us." The experience is that few customers rent one of the instruments, but that they usually buy outright. The card draws them inside and gives the salesman the opportunity of applying his art.

At Grinnell Bros., according to R. C. Elwell, manager of the Victrola department, a pleasing increase in record volume is recorded, particularly in popular selections. Also a favorable increase in Victrola sales to the early vacationists featuring Style 50 is reported. These buyers will be followed up in the Fall with a canvass for records and a proposition for exchanging the small outing machine for a larger instrument for the house.

### Sales Staff Enlarged

At the Record Shop a healthy increase in record sales is reported by Pratt Egbert, manager. Several additions to the sales force have been made. The increase in sales is attributed to the fact that the store is selling records and not merely clerking or passing out numbers asked for. This change has shown that, while persons do not buy readily or freely, nevertheless they will buy if given plenty of service and appealed to in the proper way.

### Some Popular Recordings

"Lovey Dove," from "The Rose of Stamboul," fox-trot, Carl Fenton's Orchestra; "The Sun God," fox-trot, Isham Jones' Orchestra, both Brunswick records, and "Rosy Posy," from "The Blushing Bride," and "California," Vocalion records, are enjoying wide popularity.

### Strong Demand for Portables

At the J. W. Greene Co., Talking Machine Manager A. E. Kopf states a brisk demand exists for portable Victrolas. Never in the history of the department has there been so many Style 4-6-9 and 50 Victrolas sold during the vacation season. Moreover, many talking machines have been sold which went as gifts to June brides.

### Takes on New Lines

In line with the expansion policy of the house the following changes are announced: The Brunswick phonograph agency has been acquired for Fremont, O. A downtown branch store will be opened and will be in charge of C. E. Struble, who is now representing the J. W. Greene Co. in that city. Further, the Cheney agency was secured for Fostoria, where a branch store is maintained in charge of Geo. Moore.

Miss Manton, of the record department of the Toledo store, is spending her vacation in short sojourns to nearby resorts. A. E. Kopf, manager, is motoring East to Washington, Baltimore and other points. The intention is to spend some time at the Victor factory.

The Lion Store Music Rooms, according to A. J. Pete, manager, have tripled June sales over a year ago. The demand has been greatest for Victor console types and portables. Many outing machines go to cottages, yachts, canoes and autoists. It is indeed a sight worth seeing at Walbridge Park of an evening to watch the many canoes paddle up and down the river, each supplied with a portable, and rendering music which may be heard far over the placid Maumee.

### "A Dime a Day" Campaign

A dime a day campaign to exploit the \$25 Victrola was started June 25 and continued for a week. Machines were delivered upon the purchase of four Victor records. Payments of 10 cents a day can be made weekly or monthly as preferred. Half-page advertisements in newspapers launched the campaign and a five-column

(Continued on page 66)

## THE PHONOMOTOR CO.

W. F. HITCHCOCK, Proprietor

121 WEST AVENUE  
ROCHESTER, N. Y.

5 years of success everywhere



THE PHONOSTOP

100%  
Efficient

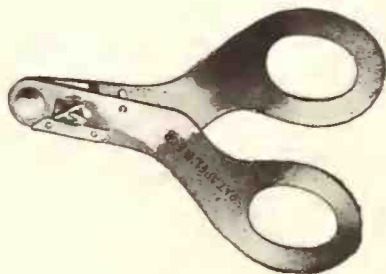

THE NEED-A-CLIP

Two Well-known Phonograph Accessories Needed in Every Instrument of Class. Satisfaction Guaranteed in Every Case

Once adapted becomes permanent.

A WHOLE PAGE of references if desired.

DON'T DALLY with inferiors, get THE BEST.

PHONOSTOPS are universal, STANDARD, and finished in nickel and gold.

NEED-A-CLIPS in nickel only.

Get Our Printed Price List Immediately

Samples sent by parcels post C. O. D.; money back if unsatisfactory, but you'll want more.



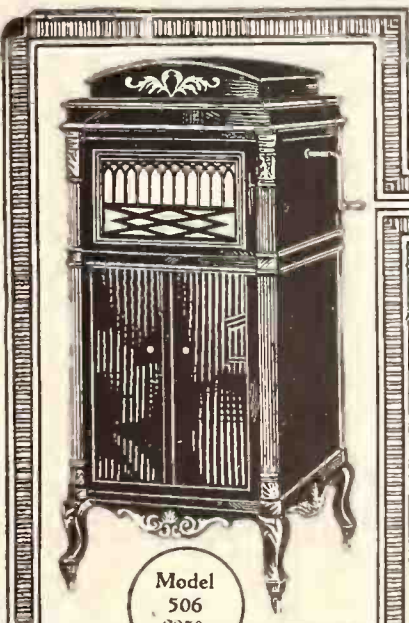

Model 506 \$250



Model 502 \$125



Model 503 \$165

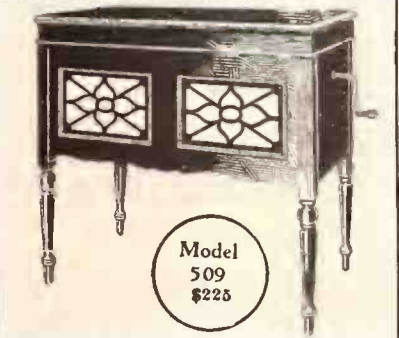

Model 509 \$225

# STEGER

*the finest reproducing Phonograph in the World*

**I**N its faithful reproduction of all music the Steger Phonograph is distinctive.

It is also a work of art. The rare excellence of the woods, the true craftsmanship shown in the cabinet work, the attractive designs of the various models, the piano finish — all these are deserving of emphasis and praise, equal to that given the Steger's wonderful powers of perfect tone-reproduction.

### INSURE YOUR SUCCESS!

The artistic Steger offers a big advantage to merchants by this remarkable combination of appeals to the varying tastes of discerning customers.

Let us tell you about attractive open territory. Investigate our effective plan of merchandising and extensive national advertising. Then you will recognize the opportunity—you will want to sell the Steger.

*Phonograph Division*

## STEGER & SONS

*Piano Manufacturing Company*

Established by John V. Steger, 1879

Steger Building, - - CHICAGO, ILL.

Factories: Steger, Illinois, where the "Lincoln" and "Dixie" Highways meet.

*"If it's a Steger—it's the most valuable Piano in the world."*



Model 505 \$200

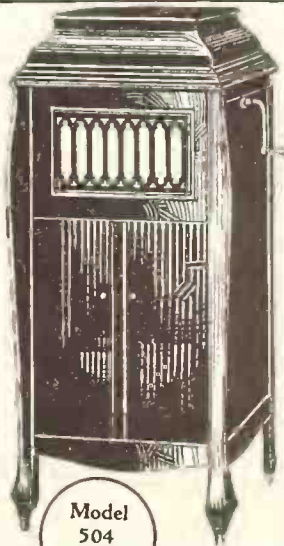

Model 504 \$150

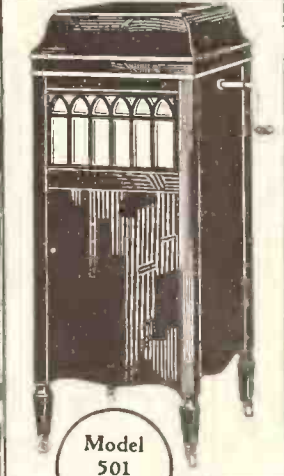

Model 501 \$100

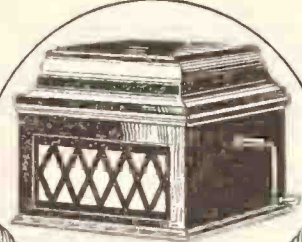

Model 500 \$65



Model 510 \$250



HAPPENINGS IN THE TOLEDO TRADE

(Continued from page 64)

cut of Style 4 Victrola was a feature of these ads. Several large window displays were also employed in this effort. This dime-a-day drive has been an annual event with the Lion Store for the past five years and is always a tremendous selling force.

Elaborate plans are under way for the annual store outing day which will be observed this year at Sugar Island, which lies at the mouth of the Detroit River and is about fifty miles across the lake from Toledo. The steamer "City of Toledo" will transport the entire force, which numbers several hundred, to the island.

Games of every nature to suit the tastes of young and old alike will be provided. They will include baseball, races, contests of skill and a prize waltz. The store will furnish refreshments.

News Brieflets

The Radiola Co., manufacturer of the Radiola receiving instrument, is going to talking machine dealers with a proposition to make Radiola-phonographs out of talking machines. The possibility of quick turnover by combining the two is dwelt upon in the campaign.

On July 1 the Goosman Piano Co. completed plans for absorbing the Starr Piano Co. store. The business will be housed in the original Goosman store.

Record and machine trade at the Cable Company is showing marked improvement. Kenneth Frederick, formerly assistant manager of the Victrola department at Grinnell Bros., is now in charge of the same section at the Cable. He has in formulation aggressive sales and advertising plans which he will put into effect as soon as possible.

Warren Kellogg, Ohio representative of the Toledo Talking Machine Co., is enjoying his vacation fishing for bass in Michigan.

R. O. Danforth, manager, Victrola Shop, the LaSalle & Koch Co., is motoring East to Boston, the Berkshires and other centers.

DISCUSS RADIO PROBLEM

Talking Machine Men, Inc., Hear Several Authorities Express Opinions on Radio

The most important topic of discussion at the monthly gathering of Talking Machine Men, Inc., held at the Café Boulevard, New York City, Wednesday, June 21, was the question of radio and the future possibility and the present profitability of the installation of receivers by retailers.

The main speaker was R. F. Yates, radio editor of the New York Evening Mail, who gave as his opinion that although in some circles the electrical dealer was considered to be the best equipped for the distribution of such goods there had lately been a more predominating opinion that the music dealer was the more logical outlet. In reviewing the problems of the music dealer, however, he made the point that much care should be taken in the stocking of electrical parts, and in the strictly technical end of the radio business.

C. L. Dennis, of the Trade Service Bureau of the Music Industries Chamber of Commerce, followed Mr. Yates and his remarks were in evident agreement with much of what Mr. Yates said. In addition, he had the word of David Sarnoff, a director in the Radio Corporation of America, that it was agreed the music dealer would take a predominating position in the distribution of radio products.

At the last gathering of the Association a committee of three, composed of M. Max, Harry Cohn and Nathan Goldfinger, was appointed to investigate the possibility of radio distribution by the talking machine dealer. A report by M. Max showed that the committee had been quite active. It was pointed out that the dealer must take much care in the buying of such goods; a minimum discount should be arrived at and adhered to and should be sufficient to cover the music dealer for the service rendered and allow a profit for carrying on such business. It was

advisable also that there be territorial allotment. Nathan Goldfinger was appointed chairman of the committee to carry out the details of a proposal to have 100 dealers, interested in radio retailing, join together and work out details for buying in combination.

The Edison dealers have never been very active in the Talking Machine Men, Inc. However, at this meeting L. J. Rooney presented the names of seven Edison retailers and an Edison group of the Association is to be formed.

B. Guy Warner, 549 Nostrand avenue, Brooklyn, N. Y., was elected vice-president of the Edison division of the Talking Machine Men, Inc., by the Edison dealers present.

The date for the next meeting of the Association has been set for July 12, at which Otto Heine-man, of the General Phonograph Corp.; George E. Brighton, president of the Sonora Phonograph Co., Inc., and Edward Strauss, of the Brunswick-Balke-Collender Co., will talk on the future of the phonograph industry.

Song demonstrators from Joe Mittenenthal, Inc., sang two numbers from that firm's catalog, "Tell Her at Twilight" and "Sunshine Alley."

Abram Davega, of the Knickerbocker Talking Machine Co., well-known Victor distributor, announced that on July 6 a director of the Educational Department of "System" would address the meeting of dealers at the Knickerbocker Auditorium.

Louis A. Schwarz, H. Reinhardt and Lambert Friedl, of the Triangle Radio Supply Co., were voted associate members of the organization.

"PAL" MACHINE SELLING WELL

The portable phonograph manufactured by the Plaza Music Co., under the trade name "Pal," is having a substantial sale in all parts of the country, according to one of the officers of the Plaza organization. Distributors have been appointed in centrally located territory and deliveries are now being made almost overnight, giving to dealers a high-class service.

**YOU NEED**  
**HALL FIBRE NEEDLES**  
 in your business to give  
 Satisfactory Service to your customers.  
 Order from Your Jobber TODAY.  
**HALL MANUFACTURING CO.**  
 Successors to B & H FIBRE MFG. CO.  
 33-35 W. Kinzie St. Chicago, Ill.

Date.....

Jobber's Name .....

Address .....

Gentlemen:—Please forward via .....

..... CARTONS COMBINATION HALL FIBRE NEEDLES  
 25 pkg. No. 1—50 pkg. No. 5.

..... CARTONS NO. 5 PACKAGES HALL FIBRE NEEDLES  
 100 pkg. in carton.

..... CARTONS NO. 1 PACKAGES HALL FIBRE NEEDLES  
 50 pkg. in carton.

DEALER'S NAME .....

ADDRESS .....



# The Trade in **BOSTON** and **NEW ENGLAND**

JOHN H. WILSON, Manager  
324 WASHINGTON ST., BOSTON, MASS.

BOSTON, MASS., July 8.—The Summer has now set in earnest and much hot weather and a great deal of rain have placed the month of June quite to the fore among the twelve periods of the year. Also comes to an end the first half of 1922, which, on the whole, has not been so very bad, though it could, as everyone wishes that it might, have been better. With the beginning of the last half of the year comes a long double holiday, for the trade for the most part agreed, as the Fourth comes on Tuesday, to throw in Monday for good measure, but to do this consistently and not overdo the idea it was planned to keep open all day Saturday, the first of the month. This was gracefully accepted by everyone in view of the added advantage.

### National Education Convention Brings Crowds

The past week was a busy one in the trade. There was in convention here the National Education Association, which brought fully 15,000 teachers and their friends into the city. Music was prominently featured and Director O'Shea, of the music department of the Boston public schools, has been rehearsing for some time a large chorus which held forth on several occasions in Mechanics Hall and other places. A large proportion of the teachers were talking machine enthusiasts and, as a special tribute to the visitors, many window displays making a special appeal along this line were arranged for by the retail stores.

### Filled With Good Material

The second issue of the Hallet & Davis Salesman is out and is in every respect a fit companion to the first number. It is filled with good material for the talking machine man, as well as for the piano man. It is planned with each succeeding issue to more and more feature the talking machine which is put out by this house.

### Music Trade Association Luncheon

Owing to the lateness of the season the third of the series of luncheons of the New England Music Trade Association held at the Engineers' Club the middle of June was also the last. President Frank S. Horning, the Boylston street merchant, was absent, being on a trip, and was naturally missed by the assemblage, which was not as large as at the previous two luncheons. The special guest of the occasion was Everit B. Terhune, publisher of the Boot & Shoe Recorder, member of the foreign commerce department of the Committee of the National Chamber of Com-

merce at Washington, D. C., and a student of international economics.

Mr. Terhune at the close of the luncheon entertained the members with an address on "The Butcher's Bill," which, being interpreted, means the price that is to be paid for the slaughter of men in the late war, a price that must be paid one way or another, as Mr. Terhune pointedly brought out. He spoke of his several trips to Europe and gave a near view of the conditions that obtain abroad and he showed that only in proportion as the economic conditions in Europe change will American prosperity be widespread. He had much to say about the Republican Party, what it has done and has not done, spoke in considerable detail about what high tariff on certain commodities has done by way of retarding progress in this country, and the Soviet propaganda, which, he declared, is very widespread, came in for a severe arraignment. Mr. Terhune received great applause at the conclusion of his talk and there was general regret that more members had not availed themselves of the pleasure of hearing him.

There was no lack of entertainment. Miss Mildred Efford and Miss Florence Fitzgerald were present through the courtesy of the B. F. Keith Vaudeville Exchange and gave musical selections, and Herbert W. Smith, baritone, who made a big name for himself as a song leader during the war, gave several vocal selections. Before and during the early part of the luncheon Arthur Morse played a medley of selections on the piano, generously contributing his services, as he did at a previous luncheon.

In the meantime let credit be given to the committee which worked up the program: Walter Gillis, the Victor dealer of Boylston street, who put a lot of time into the plans; Jerome Murphy, of the Steinert Co., and Leonard Wright.

### New Accounting System a Success

Manager Fred E. Mann, of the Columbia Co., in an informing conversation a few days ago said that the new accounting system put into operation a while ago is working out most satisfactorily and is resulting in a great saving all around, expenses alone in his department having been greatly reduced. Mr. Mann a few days ago went down to Bridgeport, accompanied by George P. Donnelly, and there they were in consultation with some of the Columbia officials and factory executives relative to the new type

of motor with which the company has been experimenting for some time, and which was lately perfected in the Columbia laboratories. This, he says, is to be put on the market in the Fall.

### Business Conditions Shaping Up Well

Manager Mann has been doing a great deal of traveling lately, having made a pretty complete canvass of his territory, and in most of New England, where he has visited with the exception of the State of Maine, he has found business conditions shaping up pretty well, the one place where business was not good being Vermont, and this because of the poor dairy and crop conditions, not to mention the prevailing strikes in the marble quarries. The only field not yet covered in New England, said Mr. Mann, is Maine, and either he or Mr. Donnelly will make the canvass of that State within the next few weeks, visiting every Columbia dealer there.

### Columbia Officials Welcomed

President H. L. Willson, of the Columbia Co., and General Sales Manager George W. Hopkins were in town a few days ago and were entertained by Manager Mann. This was President Willson's first visit to the Columbia Co.'s headquarters at 1000 Washington street, and he was favorably impressed with the splendid facilities that the Boston branch has for handling business.

### A. C. Erisman Becomes Vocalion Jobber

Arthur C. Erisman has just contracted to handle the Vocalion records for the New England territory, the deal having been completed during a recent visit here of Oscar W. Ray, who is manager of the wholesale record department of the Vocalion business. Official announcement of this new relation with the Vocalion will be made in the newspapers in a few days and the home company in New York will make a similar announcement of Mr. Erisman's representation of Vocalion records. Mr. Erisman, who will operate under the title of the Arthur C. Erisman Co., is especially pleased that he has been able to secure this line, for he has long felt that the Vocalion was one of the specially high-class types of records on the market to-day.

Manager Erisman is feeling most optimistic over the way the Strand and Outing machines have been gaining in popular favor and in his enthusiasm he does not fail to speak in the highest terms of the popularity of the Walter Camp line of records which Mr. Erisman contracted to

(Continued on page 68)

## DITSON VICTOR



## SERVICE

## Are Your Record Racks For Stock or Storage?

By giving the catalog a real chance and not concentrating on monthly supplements alone your Victor Record business can be increased materially. DITSON SERVICE offers worth while suggestions to that end.

CHARLES H. DITSON & CO.  
NEW YORK

OLIVER DITSON CO.  
BOSTON



## THE TRADE IN BOSTON AND NEW ENGLAND—(Continued from page 67)

handle for the New England territory only a few months ago. He says that the original consignment of goods which he took for distribution through New England for a year was entirely exhausted in a few weeks, which may not be surprising when it is stated by Mr. Erisman that there are now 1,400 dealers in New England to whom he is selling merchandise.

**Norman Mason Badly Injured**

The many friends of Norman Mason, who is now the retail manager for the Grafonola Co. of New England, will be sorry to learn that he was badly injured Tuesday, June 27, while at an outing of the Reciprocity Club, near Peabody. He was playing in a baseball game and made a rather unusual strike, sending the ball so far away that he was able to make a home run. Just as he reached the plate he slipped and fell, badly injuring one of his knees. He was taken to the Peabody Hospital, and for the succeeding several days suffered intense agony. He has since been brought home and is receiving the best possible attention, but it will be some time before he will be able to leave his bed.

**Attended Ponselle Concert**

Several of the local men connected with the Columbia Co. went to Hartford a short time ago to be present at the concert which Rosa Ponselle, exclusive Columbia artist, gave at Foot Guard Hall, that city. The Columbia dealers in Hartford were able to get considerable interest created in this artist, whose singing was of such an effective character that any number of good sales of Miss Ponselle's record was the resultant effect. Fred C. Collins, of the Boston branch of the Columbia quarters, worked hard to make the concert a success and through his instrumentality the Columbia dealers in Hartford devoted some of their windows to displays featuring this artist.

**F. S. Horning's Pleasant Vacation**

Frank S. Horning, head of the Boylston street establishment bearing his name, and who is also

president of the New England Music Trade Association, got in his vacation early this Summer, for already he is home and reviving pleasant memories of the many places he and Mrs. Horning visited while away. From Boston they motored down to New York, Philadelphia and Atlantic City, thence into northern New York, taking in Watkins Glen and Saratoga, then over to Williamstown, motoring over the Mohawk trail and finally back to Boston. Mr. Horning has found the early Summer business about normal. With the great throng of people who daily pass by this store he ought to find a pretty good Summer business.

**Joins Hallet & Davis Force**

The Hallet & Davis Co. has recently added two new men to its staff and they will devote all their time to pushing to the fore the talking machines of this house in the New England territory. These men are C. E. Kammler, lately with the Lansing Sales Co., and George E. Kimball, who has been in the repair department of the Hallet & Davis Co. for some time, and who gives promise of becoming a good road man. Mr. Kammler, through having been around considerably in the interests of several of the best houses in the last few years, is well acquainted with the trade and the field. R. O. Ainslie, the new secretary of the Hallet & Davis Co., who is focusing much of his attention on the Hallet & Davis phonograph line, has lately signed up with several good houses to handle this machine.

**Pushing the Brunswick Proposition**

Manager Harry Spencer is making no plans for a Summer vacation, as he wants to keep close to business during the next few months and lose no opportunity of pushing the Brunswick proposition. It is his custom to spend the forenoon and the early afternoon at the new salesrooms in Boylston street in the heart of the music section, and the late afternoons he goes down to the wholesale headquarters farther out on Boylston street. At the showrooms there is a fine line of

**An Antidote for  
Summer Dullness  
IS FOUND IN  
"LONG QUALITY" CABINETS  
"PEERLESS" ALBUMS**

They are both good all-year-'round sellers. If you do not already carry these lines, write today to

**L. W. HOUGH**

New England Representative  
20 SUDBURY STREET BOSTON, MASS.

choice Brunswick models. Mr. Spencer states that business is moving along very well and that the business for the first half of the current year showed an increase over that of the same period in 1921. He reports that among the new connections lately formed for handling the Brunswick is the Gibbs Piano Co., of Springfield, which took a large initial order.

**Kenneth Reed a Busy Man**

These have been busy days for Kenneth Reed, manager of the wholesale department of the Victor at the Steinert establishment, and after his trip to the Atlantic City convention he feels more like staying home these days and confining himself to visiting the trade, using his car when it comes to going any distance and especially when visiting Providence, Worcester, Springfield or points in Connecticut. Mr. Reed now has his family settled in his Summer estate on Cape Cod, where there are excellent opportunities for playing golf.

**Lloyd Spencer Guest of Robert Steinert**

A recent visitor to the Victor trade was Lloyd Spencer, of Silas Pearsall & Co., who for one day was the guest of Robert Steinert at the latter's beautiful Summer estate at Beverly, on the North Shore. They motored out and enjoyed eighteen holes of golf, Mr. Spencer remaining overnight and coming back to town with Bob in the morning.

**KRAFT-BATES AND SPENCER INC.**  
NEW ENGLAND DISTRIBUTORS

of  
**Brunswick**  
PHONOGRAPHS AND RECORDS

**Do You Want to Deal With 77 Years of Square Dealing?**

The House of Brunswick was established in 1845—long before phonographs were invented.

For three-quarters of a century it has borne an international reputation for quality products and sound business policies.

The notable enthusiasm of Brunswick dealers for their line is only the logical result of broad, generous policies. Within the past year Brunswick withdrew 15,000 phonographs from dealers' stocks and rebuilt them, to protect dealers on a change of model.

The Brunswick dealer who enters the field now is in a particularly enviable position. A letter brings our representative ready to go into details.

**KRAFT - BATES AND SPENCER, Inc.**  
1265 Boylston Street - - Boston, Mass.

Steel Needles

Albums

Record Brushes

Khaki Covers

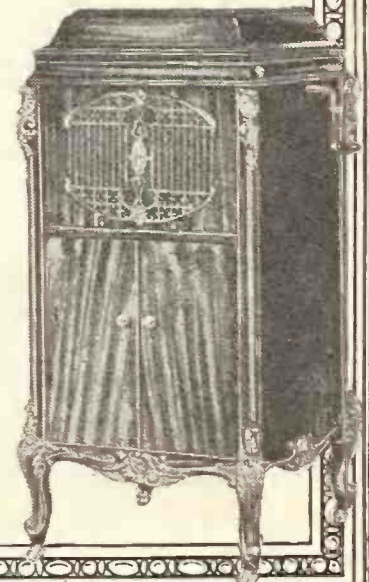



Speaking of Bob reminds one that he and his father, Alexander Steinert, head of the Boston house bearing the family name, are going to keep bachelors' hall this Summer, as Mrs. Alexander Steinert and their talented young son, Alexander, Jr., are going abroad, sailing about the middle of July on the "Aquitania." Alexander, Jr., was graduated last week with honors from Harvard and once abroad he will spend several years there studying music, as it is his intention to devote himself to composition. A number of his pieces have already been heard in public.

**Eastern Talking Machine Co. Changes**

Several changes at the Eastern Co. are announced which became effective July 1. A. N. Hersee, who has represented the Eastern in western Massachusetts and Rhode Island for three years, has resigned, as he has planned to go with a motion picture corporation. E. P. Johnston, who has been attending to the Eastern Co.'s interests in Maine, New Hampshire and Vermont, has been transferred from that territory and will succeed Mr. Hersee in the latter's field. John McGuire, who has long been a valued employe of the Eastern, has been assigned to Mr. Johnston's territory.

**Notable Sonora Visitors**

F. J. Coupe, vice-president of the Sonora Co., was in town a week or more ago, accompanied by J. O. Morris, president of the Musical Supply & Equipment Co., having come to Boston to confer with Manager Joseph H. Burke, of the New England territory. In conference with this group also was H. J. O'Connor, assistant sales manager of the Sonora Co., who had just completed a tour of the New England territory. Mr. Burke subsequently took a trip over the Connecticut field, from which he has just returned.

**Important New Cheney Agencies**

Stephen Colahan has lately completed a tour of some of the New England centers in the interest of the Cheney line of talking machines and he announces some new representations who have lined up with this company's goods. These include the Steiger-Cox house, in Fall River; the United Talking Machine Co., of Brockton; D. S. Marsh & Co., at New London, Conn., and Flint Brickett & Co., of Springfield. Plans are under way to inaugurate a Cheney campaign at the Quincy headquarters of Henry L. Kincaide & Co. early in July. It will continue three weeks and will be in charge of Frank A. Colahan.

**John Maguire a Benedict**

John Maguire, traveling man for the Eastern Talking Machine Co., has become a benedict, having lately married Miss Margaret S. Riley. Both Mr. Maguire and Miss Riley have been residents of Reading, in which town the couple

# EASTERN SERVICE

NEW ENGLAND SERVICE FOR NEW ENGLAND DEALERS



Having no retail connections — either directly or indirectly — and with our efforts and interests concentrated on your problems, Mr. Dealer, we can serve you best.

*Wholesale Exclusively.*

85  
ESSEX  
ST.

**THE EASTERN TALKING MACHINE Co.**

VICTOR DISTRIBUTORS

BOSTON  
MASS.

have taken up their residence, following a honeymoon trip into the White Mountains and over to New York. Mr. Maguire's associates in the Eastern Co. did not forget to do the proper thing when it came to wedding gifts.

**W. E. Birdsall Keeps Close to Business**

Manager W. E. Birdsall, of Vocalion Hall, is keeping his ear and eye close to business these days and he does not know if he will be able to get away on a vacation. If he does it will be to go over to Brooklyn, N. Y., which is his home city, and while there naturally he will see more or less of the Aeolian-Vocalion people. Three people of his old staff at the F. H. Thomas Co. whom he has brought with him to Vocalion Hall are: C. M. Moore, Miss R. Precourt and Mrs. L. I. Keeting. Manager Birdsall says he sees business picking up some.

**Attended Educational Convention**

W. A. Willson, manager of the educational department of the Columbia, and Miss Grace Drysdale, the company's educational representative in New England, came to Boston for the con-

vention of the National Education Association, held here this week. Miss Drysdale has been in Maine for three weeks, spending her vacation at Bar Harbor.

**Columbia Agency Change in Taunton**

Through the Boston headquarters the Columbia Co. has just established relations with the Bostock Furniture Co., of Taunton, by which this house takes over the Columbia franchise formerly held by the Dana Furniture Co. This department will be in charge of Mr. Bostock personally, and he will be assisted by Miss Jackson, who is experienced in handling the Columbia product.

**E. H. McCarthy's Success**

E. H. McCarthy, crew manager of the Columbia campaigns, which have been under way in the New England territory for some time now, has been meeting with pronounced success. He has just put over an especially successful campaign at New London, Conn. As it is, he has the "hiring and firing" of canvassers;

*(Continued on page 70)*

**Announcing Price Reductions**

of  
**"Perfection" Edison Attachments**  
 and  
**"Perfection" Reproducers**

The "Perfection" Flexi-Tone Edison Attachment (No. 4 and No. 7) as illustrated, attached to all types of Edison Disc Machines, makes the most perfect attachment available for playing all makes of lateral cut records requiring steel, tungstone or fibre needles. Only first quality mica diaphragms used in "Perfection" reproducers, giving clear, natural tone. The horizontal ball-joint and direct uplift construction give freedom of movement so that attachment may be used with or without lever, giving excellent results.

Retail price \$9.00 Gold. \$8.00 Nickel.

The "Perfection" Pur-I-Tone Edison Attachment (No. 6 Universal) plays All makes of records on New Edison Disc Machine.

Retail price \$10.00 Gold. \$9.00 Nickel.

The "Perfection" Edison Attachment (No. 4 and No. 2) plays all makes lateral cut records on New Edison Disc Machine.

Retail price \$7.00 Gold or Nickel.

The "Perfection" Pur-I-Tone Reproducers to play all makes hill and dale records on Victor Machines.

Retail Price \$6.00 Gold. \$5.00 Nickel.

*NOTE—Special Discounts to Dealers, also Quantity Prices on Request*

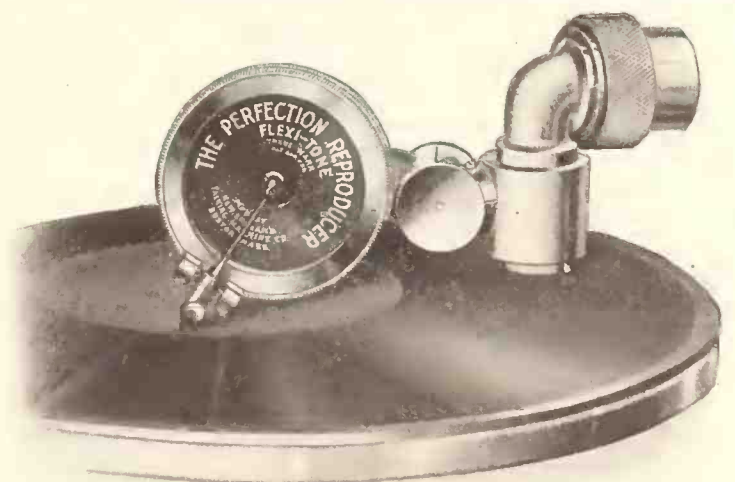

The "Perfection" Flexi-Tone Reproducers to play all makes lateral cut records on Victor and Columbia Machines.

Retail Price \$6.00 Gold. \$5.00 Nickel.

The "Perfection" Pur-I-Tone Reproducers to play all makes hill and dale records on Columbia Machines.

Retail price \$6.50 Gold. \$5.00 Nickel.

**New England Talking Machine Co.**

**16-18 Beach St., Boston, Mass.**



## THE TRADE IN BOSTON AND NEW ENGLAND—(Continued from page 69)

he has received a valuable training in the careful selection of good people for this sort of work, and it is largely due to his keen insight that he has been able to gather around him such a group as can produce the best results.

#### Congratulations

Miss Isabel Elkins, of Somerville, for several years an employe of the Hallet & Davis Co., in the collection department, has become a bride, her husband being Edward Kelleher, of Cambridge. The bride's associates in the Hallet & Davis Co. presented her with a handsome tea wagon.

#### Attended Meisse Co. Opening

H. C. Spain and Arthur Forbes, of the Hallet & Davis Co., made a flying trip by auto to Northampton the latter part of the month, to be present at the opening of the new store of the J. L. Meisse Piano Co., at 27 Pleasant street. They described the store as an exceedingly handsome place, with the new Hallet & Davis talking machine given conspicuous representation. They

also took a run over to North Adams to look the field over. A week before Messrs. Spain and Forbes visited Springfield to take part in the opening of the Gibbs Music Co.'s store.

#### Some Vacation Brieflets

Herman Baker, of the A. M. Hume Music Co., spent several days at his father's estate on the shores of Lake Sunapee, N. H., but there was so much rain that he could get about with his car very little and he therefore returned to Boston rather disgusted with the weather.

Herbert Shoemaker, wholesale manager of the Eastern Co., hasn't given much thought to vacations up to this time other than to come to the tentative conclusion that week-end motor trips to attractive places will work out as pleasantly as anything.

Francis T. White, manager of the talking machine department of the C. C. Harvey Co., has planned to take his family to Lake Sunapee, N. H., for his vacation, and will leave town toward the middle of July, to be gone a fortnight.

Winthrop A. Harvey, head of the C. C. Harvey Co., enjoyed a cruise along the coast of Maine the latter part of June. He took the Bangor steamer from Boston, leaving the boat at Northport, Me., where he was joined by a group of friends for the cruise.

Ernest A. Cressey, of the Harvey Co., has planned to spend his vacation this season at Jackson, N. H., where he and Mrs. Cressey will be guests at Gray's Inn, one of the popular places in the mountains. They will motor up to the resort and enjoy many mountain trips while at Jackson.

Chester J. Sylvester, manager of the talking machine department of the C. E. Osgood Co., is planning to take his vacation on the shores of Lake Winnepesaukee, N. H., where he lately purchased some property on the shore front. Your correspondent saw the record of his sales, which warrants the statement that he has had a very satisfactory month, considering all the circumstances facing trade in general.

#### REDUCE TAX ON KNOWLEDGE

Why Bill to Lower Second-class Mail Rates Should Win Universal Support

A bill which vitally affects all business men, and particularly the readers of advertisements and users of newspapers, magazines and the business press, was introduced recently in Congress by Congressman Kelly. It has for its purpose the reduction of the second-class mail rates. In connection with his bill, Congressman Kelly spoke in part as follows:

"Newspaper and magazine publishers of the country are in need of relief from the discriminatory war tax in order that the press may continue to function. The proposed measure retains the present zone system of postal charges, but proposes to reduce the amount of the charge from the fourth advance, effective July 1, 1921, to the second advance in rates, which became effective July 1, 1919. The rates asked for would still give the Government 175 per cent more than the pre-war rates and would not relieve the publishing industry of one cent of the other Federal taxes paid by it in common with other industries.

"The present postage rates on newspapers and publications were fixed in the War Revenue Law passed in 1917, and are 325 per cent higher than the pre-war rates. Everyone of the items carried in that measure, with the exception of the tax on second-class mail matter, has been modified or repealed. These wartime postage increases have driven millions of pounds of second-class matter from the mail into private channels of distribution. There is something radically wrong when private companies can make a handsome profit at rates less than those charged in postage. I believe there is no good reason why the publishers of newspapers and magazines should be singled out to pay this extra war tax.

"The fact that these high rates are charged on the advertising pages does not lessen the in-

**HEADQUARTERS**  
For  
**Single Spring Motors**  
and  
**Mica Diaphragms**  
**WILLIAM BRAND**  
27 East 22nd St., New York City

justice. Advertising is not merchandise, but information. The newspapers are information highways, just as essential to the business prosperity of this country as the highways and waterways. Not a sale can be made or a pound of goods shipped without the interchange of information. The advertisements are chronicles of every advance in industrial achievement. Without them publication of the newspapers and magazines would be impossible."

#### COLUMBIA STAFF ON OUTING

Detroit Branch Holds Successful Outing—Interesting Sports Program—Manager Gardiner Important Factor in Handling Arrangements

DETROIT, MICH., July 5.—The members of the wholesale branch of the Columbia Graphophone Co., this city, held a very successful picnic recently at Bob-Lo, an island in the Canadian waters. The entire party, including Manager Gardiner, assembled early in the morning and journeyed by way of a specially chartered steamer to Bob-Lo. In addition to the Detroit organization there were present as the guests of honor Manager Larmon and Assistant Manager Cooley, of the Columbia Co.'s Cleveland branch.

The sport program included a baseball game, which was won by Assistant Manager Brewster's team, which defeated Manager Gardiner's team by the close score of eight to six. Miss Clara-belle Young, secretary to Manager Gardiner, won the girls' race and Melvin Ploof, Dictaphone Service man, was the winner of the men's race.

In the fat men's race Ed Rockett was the winner, and in the three-legged race Ted Hastings and Miss Young were the prize winners. Miss Young's team was also the victor in the egg relay race, and in the cracker-eating contest Miss Clara Dierksen and Mr. Ploof carried away the honors.

There was plenty of swimming and dancing for all of the guests, and at the close of the day the 1922 outing was voted a signal success, thanks to the efforts of Manager Gardiner and his associates.

#### FAMOUS TENORS TO BE HEARD

Orville Harrold, Metropolitan Opera Company tenor, and Victor artist, as well as Mario Cham-lee, of the Metropolitan Opera Company, and Brunswick artist, will be heard during the Summer opera season at Ravinia Park, Chicago. Mr. Harrold is scheduled to sing in "Boheme" and "Cavalleria Rusticana" the opening week and Chamlee is to be heard in "Traviata," "Lucia" and "Manon." Chicago is to be envied in securing such noted artists.

## LANSING KHAKI COVERS

The Pioneer Moving Cover



High  
Grade

Khaki

Announcing the new

## CONSOLE PADDED COVER



SLIP AND RUBBER COVERS  
FOR PHONOGRAPHS AND PIANOS  
MANUFACTURERS

*Lansing*  
SALES CO.

170 Harrison Avenue  
BOSTON, 11, MASS.

Piano Stools, Chairs, Benches

**ACME-DIE**

**CASTINGS**

ALUMINUM-ZINC-TIN & LEAD ALL PYS  
Acme Die-Casting Corp.  
Boston Rochester Brooklyn, N.Y. Detroit Chicago



# Something You Can See Through!!

**D**O YOU believe that merchandise can be successfully sold by keeping it under the counter, on a back shelf, or, perhaps, down in the basement? Certainly not, is your answer. And yet, Mr. Victor Dealer, there are lots of intelligent merchants who are doing this very thing every day in the year—their store having become a sort of “storage warehouse.”

Just so long as merchandise is kept “hidden,” just so long will the sales of that merchandise be limited. On the other hand, it has been conclusively proven and it is an acknowledged fact that goods well displayed are more than half sold.

How are you showing your Victor Needles, Mr. Victor Dealer? Are they right up in the front of your store on the counter, readily seen, nicely displayed, where every person entering your establishment cannot miss buying them? Certainly, that’s where they should be—yes, if you want to reap the harvest of profits that is open to you and justly yours.

And there can be no better way of presenting a beautiful, attractive, sure-shot selling display than through the use of the ideal showcase now offered by the Victor Talking Machine Company to every Victor dealer.

The accompanying illustration and description hardly do justice to this money-making display case. You will have to see it to really appreciate it. The price is but \$3.00 for each case and how can you spend \$3.00 to equal advantage? One sure thing, there is going to be a temporary shortage of these display cases, so lose no time in sending the coupon in the lower corner of this page to your jobber or to the Advertising Department, Victor Talking Machine Company, Camden, New Jersey. No Victor Dealer, to be really successful, can afford to be without this ideal exhibition showcase. And, think of it, only \$3.00.

## An Exhibition Showcase—of Permanent Construction



This display case is of all-metal construction, 17½ inches wide, 7 inches high, and 8 inches deep from front to back. It has a glass panel door, through which the needles may be seen but not handled. The door is opened by means of a concealed snap-lock in the back of the case, and is supported by a brace, when open. The rear of the case contains a printed guide strip, showing the kind of Victor needles in each division. The Victor trademark is advantageously displayed in full colors on the front and ends of the case, and across the vertical face appear the words “Look for This Trademark on All Victor Products.”

The case has room for a complete stock of Victor needles. From left to right, there are seven divisions, which display, in the order named: Victor Full-tone Steel Needles, Packages of 100; Victor Half-tone Steel Needles, Boxes of 500; Victrola Tungs-tone Stylus, Soft Tone, Boxes of 8; Victrola Tungs-tone Stylus, Full Tone, Boxes of 8; Victrola Tungs-tone Stylus, Extra Loud Tone, Boxes of 8; Victor Full-tone Steel Needles, Boxes of 500; Victor Half-tone Steel Needles, Packages of 100.

**C. BRUNO & SON, Inc.**  
 351-353 Fourth Avenue New York  
*Victor Wholesalers to the Dealer Only*

Gentlemen:—  
 Please send us  
 with all speed one  
 of the all-metal  
**VICTOR NEEDLE  
 DISPLAY CASES**  
 costing \$3.00, as de-  
 scribed in the July issue of  
 the “Talking Machine World.”



# S A I N T L O U I S

Studying Radio Situation for Fall—Business Review—Tri-State Dealers Get Together—New Agency Changes—Other Happenings

St. Louis, Mo., July 10.—Talking machine men here are viewing the mid-Summer business situation with as much fortitude as they can summon and are looking forward to the early Fall, when trade is expected to speed up immensely, aided and abetted by the radio wave, which is calculated to reach its crest along about then. All of the distributors and dealers are taking radio into account in the Autumn reckonings. Those who have taken steps to tie up the radio to the talking machine are experiencing delay, which was expected, in getting their supplies, and are not fretting greatly about it, as they figure the radio rush will not be strong until the Fall. Those who have not decided to take on radio are studying developments closely, ready to take it on as soon as they are satisfied that it has reached a stage of sufficient stabilization.

Steady improvement in general business conditions throughout this district in the past month is indicated in the monthly report of William McC. Martin, Federal Reserve Agent for the Eighth Federal Reserve District: "In virtually all lines investigated reports indicate good gains over the corresponding period last year, also over the preceding month this year. In addition to betterment in concrete results, sentiment in both city and country is considerably more optimistic than earlier in the year. The latter fact is reflected in a disposition on the part of merchants and the public to more freely supply their needs, immediate and future. Almost unanimously manufacturers, jobbers and wholesalers indicate substantial increases in unfilled orders. Many large distributors of commodities who in recent months had little or no future business

booked now have a showing of orders for forward shipment comparable with their volume during normal years in the past."

#### An Old Saying Tied to Victor Line

A new twist to an old saying is given in the advance list of the Koerber-Brenner Co., Victor distributors, in the advice to dealers to "Hitch your wagon to the stars." Says the sprightly writer of the Koerber-Brenner stimulants:

"To be very direct about it, 'your wagon' is your business. You ride in it along the road to Success. The 'Stars' are the great Victor artists. And the closer you tie your business to them the steadier and surer will your progress be.

"It's getting easier all the time to sell good music. The 'jazz' craze that started back in war-times is suffering a reaction. Of course, there'll always be a good demand for the lighter sort of music—for popular songs and dance hits. But more and more people are getting around to an appreciation of good music. Victor advertising is in a great measure responsible for this appreciation and will continue to foster it.

"So tie to the 'Stars' now—and stay with them. They are real stars. Where is there a tenor with a greater following than McCormack, a more wonderful soprano than Galli-Curci, a violinist to equal Kreisler, a pianist more brilliant than Rachmaninoff? In the music of these and of dozens of other 'stars' you have something to offer the public that no one else can offer them."

#### Tri-State Dealers to Meet

The members of the Tri-State Victor Dealers' Association will eat, dance and make merry Friday night, July 14, at the Century Boat Club.

## MICA DIAPHRAGMS

*Absolutely Guaranteed Perfect*  
We get the best India Mica directly.  
We supply the largest Phonograph Manufacturers.

Ask for our quotations and samples before placing your order.

**American Mica Works**  
47 West St. New York

F. J. Ennis, manager of the talking machine department of the Stix, Baer & Fuller Co., will furnish radio music. T. R. Husselton, of the Victor organization, will speak and sing. It will just be a get-together meeting, with no business to be transacted.

#### P. A. Starck Co. to Move

The talking machine department of the P. A. Starck Piano Co. will be greatly enlarged when the St. Louis store moves, about September 1, to a new location at the southeast corner of Eleventh and Olive streets. The Starck Co. has leased the entire building and will remodel it and occupy the first and second floors and basement. The plans for the talking machine department have not been worked out, but Manager J. E. Reger says it will be the last word in modern construction.

#### Stix, Baer & Fuller Hold Sale

Manager F. J. Ennis, of the Stix, Baer & Fuller talking machine department, returned near the end of June from a three weeks' rest at home and found that the balance sheet showed a gain over June of last year and that the business of the first half of the year was about up to the same period of last year. Popular-priced stuff went best in June, he said, with a good demand for Victor and Sonora portables. During the month the department had a sale of used phonographs. About one hundred machines were disposed of.

#### Uses Edison and Victor in Radio Concerts

Edison and Victor talking machines are used by the St. Louis Post-Dispatch in broadcasting concerts with its new sending equipment. The Edison is supplied by the Silvertone Music Co. and the Victor by the Koerber-Brenner Co.

#### News Brieflets

R. M. Kempton, wholesale manager of the Vocalion, and Harry L. Levy, Western wholesale manager, passed through St. Louis recently, returning from a Western trip.

The Silverstone Music Co. has installed on its main floor the equipment for the radio department. Some accessories have been received, but a complete stock will not be on hand for some time yet. The firm expects to be distributing by the early Fall.

The Armstrong Furniture Co., Memphis, Tenn., has taken on the complete Edison line. M. Goldberg, vice-president of the Silverstone Music Co., has returned from a visit to the Armstrong firm, which is one of the oldest in the South.

O. A. Reynolds, field representative of the Silverstone Music Co. in Missouri and southern Illinois, has returned from his vacation.

J. F. Stapleton, general sales manager of the Granby Phonograph Corp., Newport News, Va., was in St. Louis recently.

Robert Watts, formerly a salesman for H. J. Arbuckle, manager of Widener's, Inc., has established himself in the motor repair business in the Benoist Building. Miss Patricia Lanham, formerly with Mr. Arbuckle, has gone to California to live.

The Kieselhorst Piano Co., which recently had an opening for its new line of Brunswicks, reports an excellent business.

St. Louis Victor dealers are reporting a good sale of records of the light opera numbers from the operas being given in Forest Park.

F. L. Parrish, Victor dealer of Metropolis, Ill., was a recent visitor at Koerber-Brenner headquarters.

F. B. Jenkins, Jr., manager of the wholesale Victrola department of the Jenkins Music Co.,

## TONE QUALITY

*par excellence*

Purity, resonance, volume, individuality, sweetness, mellowness, nuance, color—all these qualities are faithfully reproduced by the Violin Spruce Diaphragm. Nature's perfect resonating medium—violin spruce—scientifically adapted, is free from all the inherent faults of mica and other vibrating mediums.

#### Wins Instant Approval

The following excerpts are from letters in our files:

*A famous artist, under exclusive contract with a maker of phonograph records, says:*  
" . . . that is the most perfect, the most beautiful reproduction of my playing I have ever heard."

*From a phonograph manufacturer:*  
" . . . it proves to be first-class and the best we have heard on classical records."

*From a builder of special designs only:*  
"We have concluded our tests . . . it is superior to any we have tested heretofore . . . we intend to use your tone arm."

*From household owners:*  
" . . . is the most wonderful I have ever heard."

" . . . it has brought out tones from my records I never heard before."  
" . . . I tell my friends it is the perfect reproducer."

*From a sales executive, fourteen years in the talking machine business:*  
" . . . I have tried it (the reproducer) on every kind of record imaginable and the reproduction is excellent."

Violin Spruce Diaphragm Reproducer as illustrated retails for \$7.50

THE DIAPHRAGM COMPANY  
Room 311, 5005 Euclid Ave., Cleveland, O.

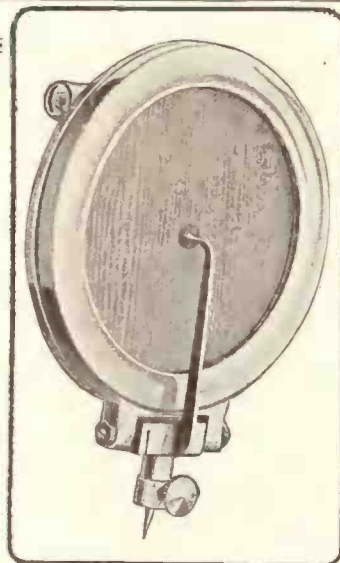

#### Of Special Interest to Manufacturers

We are prepared to furnish in any quantity the following items adapted to any make of phonograph: Tone Arm, equipped complete with Violin Spruce Diaphragm Reproducer; Violin Spruce Diaphragm Reproducer; or Violin Spruce Diaphragm alone to assemblers in 2-9/16" diameter only.

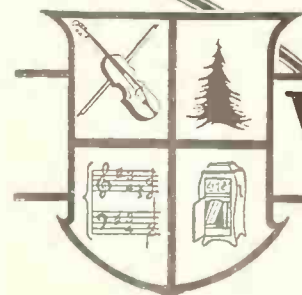

# Violin Spruce Diaphragm



Kansas City, recently visited A. W. Hosier, manager of the talking machine department of the Scruggs, Vandervoort & Barney Co.

**Conducts Sales Classes**

Morning classes are being conducted in the talking machine department of the Scruggs, Vandervoort & Barney Co. for making salespeople more familiar with talking machines and records. Manager A. W. Hosier conducts the machine class and Miss B. S. Rosebrough, educational director, has charge of the class in records. At each class session a sale is made by one of the members who is criticized by the others.

**R. V. Johnson in New Post**

R. V. Johnson, who has been made manager of the Vocalion department of the Aeolian Co. here, is working the wholesale field in Colorado and will remain in that section until the Fall. In his absence the department here is in charge of John L. Stevener.

**T. L. Husselton in Town**

T. L. Husselton, a very popular member of the traveling staff of the Victor Co., is spending a few weeks in St. Louis and vicinity, discussing business problems with Victor dealers. He will

spend one morning in the study class of Scruggs, Vandervoort & Barney, which is being conducted by Miss Blanche Rosebrough.

**A Clever Stunt**

At the close of a successful demonstration in the schools of his territory, Fay Luyster, manager of the Victor department of the Cline-Vick Stores, of southern Illinois, asks the children to help him by filling out a questionnaire telling whether or not they have a talking machine in the home and other questions. In a rural school recently sixteen answers were returned. In only four homes were there talking machines. Six of the twelve non-owners said they were interested.

**Ties Up With Artists**

A unique way of tying up with artists' appearances in St. Louis has been worked out by Miss Annabelle Weible, who is in charge of the Victrola department of the Weinel Hardware Co. at Columbia, Ill. She frames small pictures of the artists announced in two frames with a framed list of the dates and places between them and displays the group in a prominent place.

**Make Study of Record Selling**

A class in the study of record selling was held in the Koerber-Brenner Co.'s offices recently. Those attending were: Misses Thelma Bullock, of the Taylor Music Co., Moberly, Mo.; Adeline Coyle, of the F. B. Wolff Co., Chester, Ill.; Alice Heilman, of Stix, Baer & Fuller, St. Louis; Estelle Heuman, of W. C. Daumueller Co., Lebanon, Ill.; Merle Ofill, Scruggs, Vandervoort & Barney, St. Louis, and Margaret Todd, of the Todd Jewelry Co., St. Louis. Miss Blanche Rosebrough, of the educational department of Scruggs, Vandervoort & Barney, addressed the class on educational work with teachers and in the home. The class also attended the opera "Sweethearts," at the Municipal Opera in Forest Park.

**To Enlarge Wellston Shop**

The Wellston Talking Machine Shop, Victor dealer, of Wellston, expects to add materially to its floor space soon by moving a back wall, building a balcony for offices and adding some hearing rooms. Below the balcony will be built space for surplus record stock.

The Buettner Furniture Co., which had a formal opening a few days ago at its new location, Ninth street and Washington avenue, has an attractive talking machine department in charge of Mr. Jost. Columbia and Granby machines are handled.

A. W. Meyer and Miss Thea Muelhlenberg, of the Stix, Baer & Fuller talking machine department, have returned from their vacations. Miss Tillie Gerlack, of the record department, is on her vacation.

R. O. Wahlman, of the radio department of the Stix, Baer & Fuller Co., spent his vacation on an automobile trip.

Mr. Coats, of the Sonora Co., New York, went from St. Louis to his home for the Fourth of July, but returned directly afterwards to this territory.

**CLOSING HEALTHY BUSINESS**

DETROIT, MICH., July 5.—The Sherburne Mfg. Co., of this city, manufacturer of Ferro automatic stops and balance lid supports, states that it is closing a very satisfactory business and, if orders are any criterion, the usual Summer slump is not going to be as severe this year as in previous years. In a short while the company expects to have several new inventions to announce to the trade, and it is believed that these new devices will meet with a hearty reception.

**THE TALE OF A FOOLISH MERCHANT**

There was once a merchant who was exceedingly foolish. He conducted his store on the principle that a customer was here to-day and gone to-morrow. In other words, he made no effort to retain the patronage of persons enticed into his establishment. That principle is wrong. Proof? That same store is now operated by another dealer.

The ultimate result of misdirected effort is failure.

**NEW FOREIGN RECORD HANGERS**

Victor Co. Announces New Hangers in Five Languages for Early Release

In connection with the advance list of Victor records for August, the Victor Talking Machine Co. announces the issuance of five new hangers printed in Greek, Hebrew, Italian, Polish and Russian, and featuring the new July records and other good-selling records in each language.

Dealers who have made use of the hangers already issued by the Victor Co., which are of the standard size of the domestic hangers and fit into the same holders, have found that they have stimulated the sale of foreign records to a material degree and have been of substantial assistance in developing Summer sales totals.

The Bach Music Co., 22 South Broadway, Rochester, Minn., has purchased the building which it occupies. This concern also recently acquired the business of the Wagoner Music Co at 23 First avenue.

**PUSH the PORTABLE**

Portables of Quality at

- \$35 THE OUTING**
- THE PLYMOUTH**
- \$30 THE STANDARD**
- THE ORPHEUS**
- \$25 THE SPRAYTONE**
- \$15 THE STEWART**



The Plymouth

We are distributors for Geer and Gold Seal Repeaters, the biggest selling accessories

Radio Apparatus, Jones Motrola, Recordola, Attachments for Edison, Victor and Columbia, Albums and Album Sets, Bubble Books, Cabinets, Record and Roll, Record-carrying Cases, Corrugated Boards, Moving Covers, Dust Covers, Dancing Toys, Envelopes, Record Delivery Stock and Supplement, Geer Repeaters, Needles, Steel and Tungsten, Fibre Needle Cutter, Display Fixtures, Record Lights, Lubricants, Motors, Nameplates, Piano and Duet Benches, Player-piano Cleaner, Polishes, Record Cleaners, Tonearms and Sound Boxes, Springs, Strings.

Write for our 100-page encyclopedia containing illustrations and prices

**The Cabinet and Accessories Co.**

Incorporated  
OTTO GOLDSMITH, Pres.

145 East 34th St. New York

Mr. Edison Man:—

Don't Say

**"KAN'T," say "KENT"**

Write for catalog of complete line

**The KENT No. 1**

With "S" Sound Box

Has given complete satisfaction for years

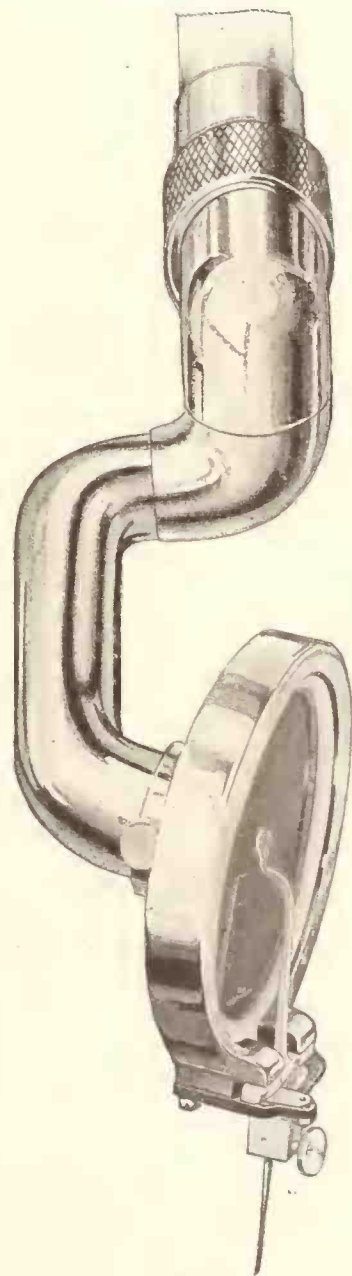

Reg. U. S. Pat. Off.

**F. C. KENT CO.**

Irvington, N. J.



# Featuring the **MUSICAL** POSSIBILITIES of the **TALKING MACHINE**

[EDITOR'S NOTE.—This is the twenty-first of a series of articles by William Braid White, devoted to the various interesting opportunities which prevail in the domain of education for the retailer of talking machines. The subject is one of great interest and we commend these articles to the consideration of all who are devoting attention to the featuring and developing of the musical possibilities of the talking machine.]

### 3. LEARNING INSTRUMENTAL VOICES

The record salesman or saleswoman who desires mastery over all the details of his or her business, that mastery which the super-salesman always has and which lifts an otherwise dull routine to the level of a joyous art, must realize that the sale of music is the sale of an illimitable thing; of something which we only begin to appreciate when we have dug deeply into it, and which only then reveals itself as ever so much

bigger than anything we ever expected to find. The mastery which the live salesman wants, whatever be the medium for the expression of his abilities, is always built upon the most complete knowledge of details. The more one knows about the little things, about the features which the customer is no more likely to know than is the ordinary salesman, the greater one's approach to mastery, the greater that sense of power which enables one to brush aside all obstacles and go on from success to success.

#### The Bigness of the Thing

That is why in these present articles I am talking so largely about what appeared to be little things, as about how to train oneself to listen rightly, how to know the inside, as it were, of

the music one offers for sale. The greatest want of the retail talking machine business today is an army of salesmen and saleswomen filled with enthusiasm for fine music and able to work the spell of their enthusiasm upon the great masses of the people who depend upon them for musical food.

Music is very wonderful. The more one knows about it the more wonderful one finds it to be. No feature of musical expression is so wonderful as the variety of the instrumental voices. Whoever can pick out from the record of an orchestral piece the individual voices of clarinet, oboe, bassoon, of horn, trumpet and trombone, of violin, viola, 'cello and contrabass, without hesitation has learned a great deal already about music appreciation and has opened up for study and enjoyment a field of unlimited depth and scope.

#### "Voyages of Discovery"

Every salesman ought to be thoroughly acquainted with every instrumental voice in the orchestra. It is now possible to buy records which show every instrument commonly included in the orchestral scores of to-day, each voice so clearly that after a little experience one finds its tone-quality stamped indelibly upon the memory. Not only is there much pleasure in listening to the little excerpts from well-known scores in which the voices of these various instruments are one by one brought forth—isolated—so that we may hear them clearly by themselves, but also a sense of discovery and of growing power. The listener learns to acquire a habit of analysis which makes the hearing of every instrumental record thereafter a voyage of discovery.

Practice is, of course, as necessary here as anywhere else. It is supposed to be easiest to begin with the wind instruments, but I believe those shades of difference which distinguish the five members of the string choir from each other should first be studied. One special reason for taking up the strings first lies in the fact that there are plenty of records for the string quartet, of two violins, viola and 'cello. To disentangle the voices of a quartet movement is one of the finest of exercises in instrumental listening.

#### Wind Instrument Specimen

There are Victor and Columbia records which give excellent specimens of the voices of almost every orchestral instrument known. The Victor educational records of the prominent companies include some specially devoted to little solos by all the commonly used instruments. Every salesman should have these records at hand for the purpose of identifying any voice heard for the first time and consequently unidentifiable. When wind instruments are being studied it is well to have at hand Columbia records A-7546, which contains a wood-wind quartet, and A-3011, which has a brass quartet. Also the very excellent A-1884, which has on one side a French horn and flute example and on the other a trio for flute, clarinet and oboe. Among the Victor records of the same kind I suggest 18655 and 35237, as well as the "Instruments of the Orchestra" record before mentioned.

Each of these should be heard over and over again, until every instrumental voice can be detected and recognized as soon as it appears. Then the study of these voices in ensemble can be seriously taken up.

#### The Quartet of Strings

If possible, however, as I said before, one should begin by thoroughly identifying the instruments of the violin family. Everybody knows, one may presume, the tone of the violin well enough to recognize it as soon as it is heard. There is no physical difference between first and second violin. The instruments are the same, but the first violin takes the highest part in the quartet. The second violin simply takes a part

## Where the Money is Made

WITH some kinds of merchandise you have to make all your profit in the first sale — because there's not much chance of a "repeat."

But with Bubble Books it's different.

The first Bubble Book purchase just starts your customer on a royal road—to entertainment for him, and profit for you.

Sell one and you've got a good prospect for the other thirteen—and it's up to you to push the sales.

*There are fourteen chances for profit in*

## BUBBLE BOOKS

"that Sing"

When you sell one you sell a habit and when you sell a habit, you're building business.

**HARPER & BROTHERS, BUBBLE BOOK DIVISION**

Established 1817

Franklin Square

New York



somewhat lower, filling in the harmonies and carrying sometimes the melodies. Of course, sometimes the first violin plays on a lower level of pitch than the second, but in general the first violin is the soprano and the second the contralto of the string quartet.

A perfectly magnificent example of the work of two violins supporting each other in this way is found in the great concerto for two violins, with string orchestra, as done by Kreisler and Zimbalist in three Victor records.

**The Lovely Viola**

The viola is a lovely instrument. It ranks a fifth lower than the violin in pitch and so is a little larger, though small enough to be played from the shoulder position. It is the alto or first tenor of the quartet. Its voice is plaintive, appealing and modest. It is like that lovely viola in Shakespeare's play—noble, modest and withal strong. Unhappily, the viola is the least appreciated of musical instruments. Those, however, who heard the London String Quartet during its recent visits to this country know that the viola can be played so thrillingly as to awaken new sensations of joy and delight in every musical heart. London String Quartet records, by the way, are to be found in the Columbia London catalog, and some are to be released soon which were made at the Columbia studios in New York during the quartet's last visit.

Opportunity to hear the voice of the viola to unusual advantage is to be found in the London String Quartet's London records of the Mozart D Minor Quartet and in some of the Flonzaley Quartet's Victor records, particularly in the allegro from the Haydn Quartet and in the allegretto from the Brahms Quartet. Also the opening phrases of the second movement of the C Minor Symphony of Beethoven (obtainable both in Victor and Columbia records) give an excellent example of viola with 'cello. The 'cello, by virtue of its very wide range, is at once second tenor, baritone and bass in the string quartet. Its beauties well repay close study and I recommend for the purpose the solo 'cello records by Pablo Casals (Columbia), Hans Kindler (Victor) and Julius Beyer (Okeh). For a splendid example of the 'cello in the quartet the Victor record of "The Flonzaleys" in the Nocturne of Borodin's Quartet should be lovingly studied.

In fact, every available quartet record should be painstakingly listened to. The task will be found delightful and will repay many times over any labor devoted to it.

**CHILDREN'S HOURS PROVE POPULAR**

Cline-Vick Stores Feature Victrolas Very Successfully in Public Parks in Series of Saturday Morning Concerts for Children

The Cline-Vick Stores, of Marion, Herrin and Carterville, Ill., have been getting some excellent publicity for their talking machine department



Children Enjoying Victrola Music

through the medium of children's hours conducted each Saturday morning and afternoon in the public parks of the various towns. Miss Ruth Mercer and Fay Luyster, manager of the Victor department of the Cline-Vick Stores, are in charge of the children's hours and the accompanying snapshot taken on the third Saturday of the series would indicate that the Victor music is highly appreciated by the little ones.

**MIDDLETON TO TOUR AUSTRALIA**

Arthur Middleton, Edison artist, and formerly with the Metropolitan Opera Company, leaves this month for an extended concert tour of Australia. He will not return before December.

**COLUMBIA NEWS BRIEFLETS**

**F. J. Herbek Returns From Honeymoon—Branch Managers Visit Executive Offices—R. F. Porter Back From Six Weeks' Trip**

Among the recent visitors to the executive offices of the Columbia Graphophone Co. were C. A. Dalzell, manager of the Columbia Stores Co., Denver, Colo., and S. H. Nichols, manager of the Columbia Co.'s Pittsburgh branch. Both of these visitors brought optimistic reports regarding business conditions in their respective territories, and Mr. Nichols was especially enthusiastic regarding the outlook in Pittsburgh.

Robert F. Porter, field sales manager of the Columbia Co., returned recently from a six weeks' trip, which included a visit to practically every Columbia branch from New York to San Francisco, and throughout the Southwest and Northwest. Mr. Porter co-operated with the branch managers in making plans for the 1922 Fall season, and many of his recommendations have already produced tangible results.

F. J. Herbek, of the advertising department of the Columbia Graphophone Co., is back at his desk after joining the ranks of the Benedicts. Mr. and Mrs. Herbek spent their honeymoon at a nearby Summer resort, and when Mr. Herbek arrived at his desk he found suitable congratulatory messages from the members of the advertising staff.

**OPENS NEW STORE IN BAYONNE**

J. E. Maloney has opened a very attractive talking machine and sporting goods establishment at 190 Broadway, Bayonne, N. J., where he will handle a complete line of Aeolian-Vocalion phonographs and Vocalion records. The store has been attractively arranged and four demonstration booths have been installed. One part of the store is being devoted to a very complete line of the latest sporting goods. The combined display is successfully attracting the public to the store. Mr. Maloney has had quite an experience in the talking machine field and expects to build up a very successful business.

**THE BEST REPEATER  
AT ANY PRICE EVER OFFERED THE TRADE**

Bevel edge conforms to arc made by needle while traversing record. Needle strikes edge of Repeater at right angle and prevents record scratching.

Adjustable rubber slide, adjustable to all widths of music on ten-inch records, prevents damage by returning needle.

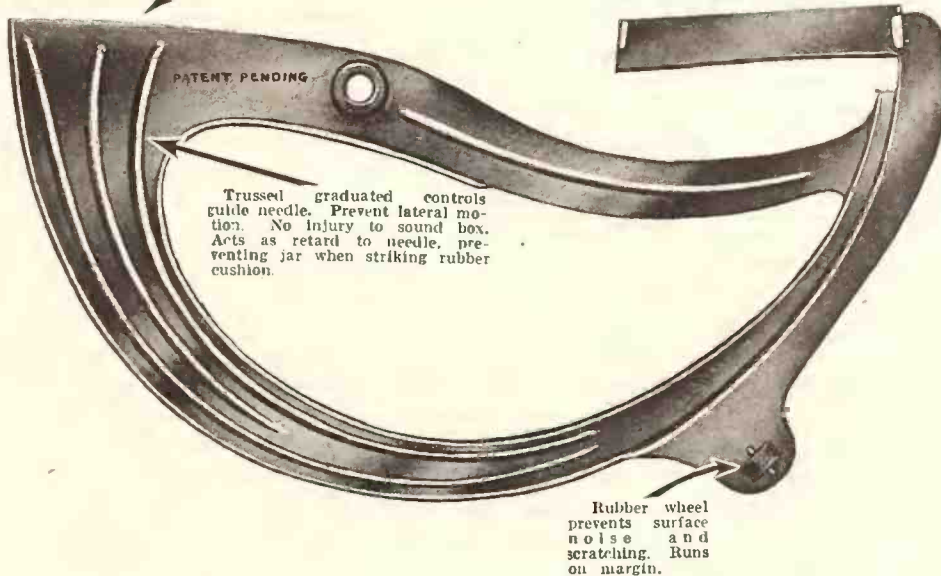

Trussel graduated controls guide needle. Prevent lateral motion. No injury to sound box. Acts as retard to needle, preventing jar when striking rubber cushion.

Rubber wheel prevents surface noise and scratching. Runs on margin.

Made of Steel; Case Hardened; Hard Nickeled  
Gold-Plated on Special Orders

**REPEAT-A-RECORD**

(TRADE MARK)

**AN IMPROVED RECORD REPEATER**

Continuous use does not affect surface.

SIMPLE—EFFECTIVE—SAFE

Does not injure or affect any part of the phonograph.

Does not necessitate a mechanic to adjust.

Reasonable retail price within reach of all.

\$1.50 to consumer; \$1.00 to retailer in less than 100 lots; 10% extra to retail dealer in lots of 100 or more.

Exclusive jobbing proposition open only to bona-fide jobbers of accredited standing; no shipments to jobbers in less than 1,000 lots. Wire us for jobbers' discounts.

**DON'T WAIT—DON'T MAKE A MISTAKE**

The REPEAT-A-RECORD will prove the livest selling specialty in the phonograph business. Get in early. We have very large advance orders now.

If you want quick deliveries **wire orders now**

**REPEAT-A-RECORD CO.**  
LOS ANGELES, CAL.

**Rudolph Wurlitzer Co., Distributors**

Cincinnati Chicago New York San Francisco





LONG  
QUALITY  
HANOVER, PA. U.S.A.

MAXIMUM  
SALES VALUE

# LONG CONSOLES

were the first cabinets introduced to the trade to accommodate table machines. They "made good" from the very start and today are recognized leaders in their field.

LONG CONSOLES have maximum sales value for the dealer knows that the purchaser of a LONG CONSOLE will be a satisfied customer. They are quality cabinets produced by a company with years of experience to its credit.

You will find that LONG CONSOLES are invaluable sales producers, and this popular line of cabinets coupled with our regular line of record cabinets will undoubtedly prove one of the most profitable departments of your business.

*Write for Complete Catalog.*

**The Geo. A. Long  
Cabinet Company**  
HANOVER, PA.



Style 600  
Sheraton



Style 601  
Colonial



Style 602  
Louis XV



Style 603  
Chippendale



Style 604  
Hepplewhite



# INDIANAPOLIS

*Close Profitable Six Months' Business—Edison Activities—Portable Machines Are Popular—Music Memory Contests Help—The News*

INDIANAPOLIS, IND., July 8.—Talking machine dealers of this city have worked a bit harder than usual to keep the month of June from showing total business less than in the corresponding month of last year. Most of them have succeeded and as a result find that the first six months of the year were more profitable than the first six months of last year. June for many of them might have turned the balance the other way. Although June was the most difficult month to meet it failed to develop discouragements, for all Indianapolis dealers have learned that the man who goes after the business never fails to get it.

### Severin Hotel Buys an Edison

Reports on Edison business for this territory are noteworthy for their optimistic tone. W. O. Hopkins, of the Edison Shop, says that June was the best June he has had in several years. Among his sales was that of one of his highest-priced art models, the Umbrian, to the Severin Hotel for use on its mezzanine balcony. His record business has shown a steady improvement through the hot weather. Mr. Hopkins says the dance records are particularly popular because of the fact that they play longer than other records.

L. L. Rosenberg, of the Edison laboratories, is spending some time at the Edison Shop, superintending the inauguration of Mr. Edison's newest sales idea, which is to be tried out here, Mr. Hopkins says, as the first experiment in the larger cities of the country. It is expected that the July report of the Edison Shop will include evidence of the practical advantages of this sales idea.

Mr. Hopkins added three salesmen to his force during June. They are: W. B. Smith, S. C. Bush and C. T. Hawkins. Also he has added two new Ford trucks to his equipment.

"Conditions continue to show steady improvement in our territory," says H. G. Anderson, general sales manager of the Kipp Phonograph Co., Edison distributor. "Our June business showed a very pleasing increase. Many of our dealers are reporting an excellent June business in both instruments and re-creations, which goes to show that the dealer who is putting his shoulder to the wheel and pushing hard, not taking 'no' for an answer, is getting results commensurate with the efforts put forth."

Walter E. Kipp, president of the company, is spending his vacation fishing in Canada.

### Outside Men Getting Results

A. C. Hawkins, manager of the Indianapolis Talking Machine Co., says that the Victor record business picked up in an encouraging manner during the latter part of June. His machine

business, he reports, has also been good during the last several weeks, due to the activities of a crew of four "outside" men. "These men have each been making on an average of three or four sales a week," Mr. Hawkins says, "which is well worth while, in view of the fact that the hot weather has reduced store sales considerably."

### Strand Phonographs and Okeh Records

Ben L. Brown, former manager of the Columbia Graphophone Co. in this city, and now general manager of the Sterling Record & Roll Co., of Cincinnati, spent a few days during the last of June with W. G. Wilson, of Widener's Grafonola Shop. He reported increasing sales of Okeh records and Strand talking machines in this State.

Mr. Wilson says his business for the first six months of this year has been better than the first months of the year indicated it would be. The Spring and Summer business has been kept up largely through the sales of the Outing portable machines and the Banner records, he says. He reports, also, a steady sale of his regular lines of Columbia and Granby machines.

### Says Radio Improves Musical Taste

Interest in the radio has developed a taste for better music and a corresponding increase in the demand for Kimball talking machines, according to C. F. Kahn, of the Capital Paper Co., Kimball distributor. He reports that the increased sales of this machine have been more noticeable recently in Indiana than in the remainder of his territory, which includes Illinois, Ohio and West Virginia. The farmers are buying much more readily than they have been, as indicated by the fact that small-town dealers are doing a considerably more brisk business than are the city dealers.

Mr. Kahn reports among his new dealers the names of Orville Wisheart, of Shirley, Ind., and R. J. Timmerman, of Batesville, Ind. E. H. Jarrard, general sales manager of the Kimball department of the Capital Paper Co., is spending his entire time on the road developing trade among the smaller dealers.

The Stewart Talking Machine Co. has made no announcement to supplement the one it sent to Victor dealers several weeks ago to notify them that the company had given up the distribution of Victor machines. It was said at the company's office late in June that an announcement concerning its future business might be made this month.

### John Cartwright Married

John Cartwright, advertising manager of the Stewart Co., married Miss Charlotte Chance, daughter of Frank Chance, Indianapolis adver-

tising man, June 26. He spent the early part of July on a honeymoon trip in the East.

### Strong Portable Machine Demand

A big demand for portable machines has made this year so far an exceptionally good one for Sonora talking machines in Indiana, according to Edward Mayer, in charge of the Sonora department of the Kiefer-Stewart Drug Co., State distributors. He says the demand for portables has been greater this Spring than ever before. Reports received by him from the dealers over the State indicate a much better outlook generally than was apparent early in the year, although in certain sections the farmers have not yet begun to buy.

### Now Traveling for the Sonora

C. C. Matthews, formerly a salesman out of the local office of the Brunswick-Balke-Collender Co., is traveling now for the Sonora line in southern Indiana and Kentucky. This is the territory he covered for the Brunswick machine. He takes the place of G. J. Corrigan, who has left the Kiefer-Stewart Drug Co. to accept a position in the Sonora factory at Saginaw, Mich.

"The outlook for Fall and Winter trade is exceptionally good," says Walter J. Baker, of the Brunswick Shop. "Not very many prospective machine buyers came to the store during May, but the number that came in June was large. That makes us feel better, whether or not it is a sure indication of the amount of business we will do later. Our business so far in both records and machines has been very satisfactory. The records of 'Stumbling' and 'Some Sunny Day' and the console models of machines have been the leaders in the last few weeks."

Miss Dorothy McCarney, who has been cashier of the Brunswick Shop, was married the latter part of June to Donald Edmonson, of Clayton, Ind. The couple are spending their honeymoon in California.

### Baldwin Co. Gains Over Last Year

The first six months of this year were much better in volume of business than the corresponding period of last year for the talking machine department of the Baldwin Piano Co., according to C. P. Herdman, manager. "It kept us working like the devil to do it, especially through June," is the way Mr. Herdman explains the good showing. He says his crew of "outside" men were largely responsible for continued sales. Their reports have been that people are looking for bargains and that the coal strike and threatened railroad strike have made them timid in buying.

T. H. Bracken, of the Starr Piano Co., says his talking machine and record sales for the first six months of the year show a marked increase over the first six months of 1921. This last June was particularly good, he says.

### Does Well With Fire Sale

The Pearson Piano Co. sold 250 talking machines in the first six weeks of its fire sale, which started May 10, according to H. A. Brown.

(Continued on page 78)

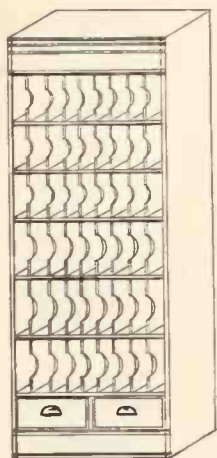

Record Rack

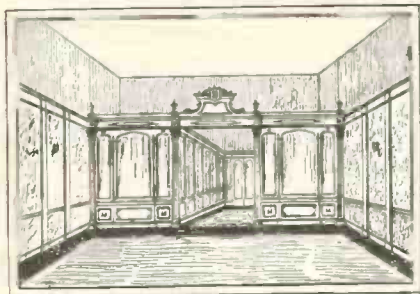

Gothic Design

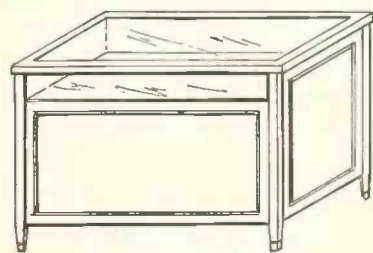

## Zimmerman-Bitter Construction Co.

Specialists in  
Sound-Proof Hearing Rooms — Record Racks — Service Counters  
and General Store Equipment for the Talking Machine Trade

**WHY EXPERIMENT?**

Let us figure on your needs—we can save you money

OFFICES, FACTORY AND WAREHOUSES:

325-327 East 94th Street

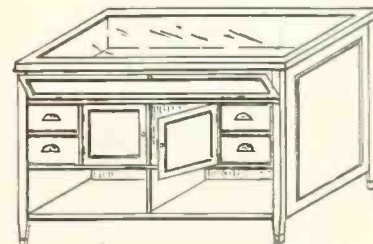

Display Counter

New York City





**You'll have to buy A-3633 early and often when folks hear Nora Bayes sing "Atta Baby" and "Cow Bells." This record is Miss Bayes at her best.**

**Columbia Graphophone Co  
NEW YORK**

### TRADE NEWS FROM INDIANAPOLIS

(Continued from page 77)

manager of the talking machine department. The sale followed a fire which damaged the company's store and made it necessary for it to do business in new quarters. Business will be resumed in the old store July 20 with an entirely new stock of machines and records, the latter including a full Victor library, Mr. Brown says. The company is revising its mailing list and in other ways is preparing for the biggest Fall trade in its history. It will continue to carry Victor, Edison, Cheney and Vocalion talking machines.

#### Wins Out With Music Memory Contests

Music memory contests have developed exceptionally good business for Grover W. Sims, Edison dealer of Oakland City, Ind., Mr. Anderson reports. Mr. Sims operates four exclusive Edison stores. He has conducted the contests once a month this year in each of four counties in which his stores are located. At the end of the school term he held a final contest, at which twenty pupils from the four counties had marks of 100 per cent. This has made it necessary for Mr. Sims to plan an additional contest for the purpose of ascertaining which of the twenty shall be adjudged winner of an Edison talking machine he has offered as a prize to the pupil with the highest grade.

#### Stimulates Edison Business in Louisville

H. T. Castello, manager of the Edison department of the Baldwin Piano Co., at Louisville, Ky., has developed a scheme which is bringing him good business in both instruments and re-creations, he says. Recently he began giving recitals at the store with students of the Louisville Conservatory of Music. The recitals

became so popular that they were given also before church audiences and at entertainments conducted by various other organizations. The featured artist has been a young woman, six-

teen years old, who is said to be one of the most promising students of Madam Cara Sapin, of the Conservatory. The popularity of these concerts shows no sign of abatement.

## THE TWIN CITIES

*Crop Conditions Create Optimism Among Dealers—Trade Stocking Up—Business Prospects Decidedly Stimulating—News of Month*

MINNEAPOLIS and ST. PAUL, MINN., July 7.—The wailing notes heard so long in the Northwest although covered somewhat by various devices representing optimism are almost completely stilled by the highly encouraging reports on crop conditions. Nothing equal to the rosy predictions have been heard for twenty years and unless some dreadful visitations appear a large and bountiful harvest is almost a certainty right now. The result is that merchants and manufacturers and everybody else are on the qui vive of expectancy. And the talking machine men are in the crowd.

#### Geo. A. Mairs Says Things Look Bright

"We now can definitely say that matters are breaking in a satisfactory manner," declared George A. Mairs, manager of the Victrola department of W. J. Dyer & Bro. "We are sorry to relate that some of the rural dealers are hard boiled in pessimism, but the majority are imbued with the prevailing spirit that the good times are right at our doors. Our books show an increase in orders. To be sure, some of the dealers are very cautious in placing orders, but it is best that way under present circumstances, and we know that they will have to stock up later."

#### Edison Dealers Beginning to Stock Up

It is reported by Laurence H. Lucker, Northwestern distributor of Edison phonographs and records, that the rural dealers are beginning to stock up for the Fall trade. Quite a number of orders for immediate delivery are being received, which indicates that local stocks are low. Good crop returns inevitably will mean good business for the jobbers and distributors. Mr. Lucker has been visiting the Edison factories for some time, selecting machines for the Fall trade.

From a retail standpoint the Twin Cities are doing well with the Edison machines. The new console models at the new low prices are proving immensely popular, according to Milton Lowy, of the Minnesota Phonograph Co.

#### Col. Sprague Visits Trade in Minnesota

Col. W. S. Sprague, of the Northwestern branch of the Columbia Graphophone Co., is back from an extended tour of visits with dealers in southern Minnesota. He reports that every mother's son is highly pleased with the outlook and predicts a fine year for the Columbia products.

#### "Business on Up-grade," Says E. F. O'Neill

"All fundamental business in our section is on the up-grade," says Eugene F. O'Neill, of Beckwith-O'Neill Co. "While everything is depend-

ent upon the crops, the latter are said to be in the best condition for many years. If the condition is maintained for a few weeks longer it will mean a tremendous upward lift for every line of business in our section. Anticipating the harvest somewhat, merchants already are doing some buying for Fall. Collections are improving. But—everything depends upon a good crop. If we get it everybody will prosper, if we don't we will have another dreary year."

#### Pathé Outlook Improves

Pathé instruments and records are going fine, according to H. F. Sharar, manager of the phonograph department of G. Sommers & Co. Due to a poor Spring and the distractions of automobil- ing, fishing and other outdoor activities the trade still is somewhat slow, but the road men are turning in more orders and report that there will be something good to be had in a month or so.

### NEW HIS MASTER'S VOICE BRANCH

Opening of Vancouver, B. C., Branch Completes Trans-continental Chain of Stores

VANCOUVER, B. C., July 8.—His Master's Voice, Ltd., has announced the completion of the last link in its chain of warehouses by the opening of a Vancouver branch, at 1206 Homer street, in this city. This completes the distribution system of the big company, giving it a chain of warehouses extending from Halifax, N. S., to Vancouver, B. C. The new branch will be in charge of J. H. Biggar, for many years connected with the Toronto, Ont., office of the company, both as a road salesman and latterly having charge of the sales force of the Province of Ontario.

The Starr Piano Co. branch at Vincennes, Ind., has been discontinued.

PERRY B. WHITSITT

Records Make Ideal Gifts

Every Victor dealer should teach his community to accept this fact. It will sell records the year around as well as in the holidays and it will sell Victrolas as well.

COLUMBUS ~ OHIO

VICTOR DISTRIBUTORS

### LAUTER MADE TALKING MACHINES

GOLDEN OAK  
FUMED OAK  
BROWN MAHOGANY  
*For Early Delivery*



Let us figure today on your requirements, or write us for illustrations and prices.

THE H. LAUTER COMPANY

Indianapolis, Indiana





Latest Design  
Beautiful Tone

Best Quality  
Lower Price

## PHONOGRAPHS

Strand Queen Anne  
Period Console  
Lists at \$125



Strand Louis XV  
Period Console  
Lists at \$150



# The Policy that Succeeds

### 1. Quality and Design

To build none but first-class instruments and to concentrate on correct flat-top consoles, every instrument guaranteed.

### 2. Low List

So that you may offer better values, make sales easier and oftener and increase your rate of turnover.

### 3. Long Discounts

To give you a liberal profit on each sale and make it doubly attractive to handle Strand Consoles.

### 4. Trouble-proof Shipping

Prompt, safe deliveries assured by an ample output and a trouble-proof shipping system.

### 5. Protection

Exclusive territory; you are protected against dividing your trade with nearby competitors.

*"It's the Dealer's Turn Now"*

### These Direct Strand Representatives are Ready to Serve You:

RICHARD H. ARNAULT, 95 Madison Avenue, New York City  
W. O. CARDELL, Tulsa, Okla.  
A. H. DANKMAN, 327 Adams Street, Buffalo, N. Y.  
CONSOLIDATED TALKING MACHINE CO., 227 W. Washington Street, Chicago, Ill.  
A. C. ERISMAN, 174 Tremont Street, Boston, Mass.  
W. S. GRAY, 942 Market Street, San Francisco, Cal.  
STERLING ROLL & RECORD CO., 137 West Fourth Street, Cincinnati, Ohio  
ARTOPHONE CORPORATION, 1103 Olive Street, St. Louis, Mo.  
H. KALISKI, Hotel Monteleone, New Orleans, La.

G. C. SILZER, 1019 Walnut Street, Des Moines, Ia.  
WALTER L. ECKHARDT, 624 Market St., Philadelphia, Pa.  
RICKEN, SEEGER & WIRTS, Globe Bldg., Detroit, Mich.  
W. F. STANDKE, 1120 Grand Avenue, Kansas City, Mo.  
MERVIN E. LYLE, 214 Peachtree Arcade, Atlanta, Ga.  
R. J. JAMIESON, 25 Taylor Arcade, Cleveland, Ohio  
H. J. IVEY, General Delivery, Dallas, Texas  
L. D. HEATER, 614 East 28th Street, Portland, Ore.  
OTIS C. DORIAN, 11 Bloor Street, E. Toronto, Ont.  
R. L. CHILVERS, 49 Lincoln Avenue, Montreal, Que.

To responsible dealers we offer a profitable franchise in localities not being yet covered. *Write or wire.*

MANUFACTURERS PHONOGRAPH CO., Inc.

95 Madison Avenue

New York

GEO. W. LYLE, President



## SPECIAL EFFORTS BRING RESULTS IN BROOKLYN

Portable Models and Records for Summer Camps in Evidence in a Sales Way—Long Island Phonograph Co. Scores in National Sales Campaign—New Establishments, Agencies and Store Enlargements—News of the Month

The Brooklyn and Long Island talking machine trade during the past month has been generally quiet, but, as usual, there are always some dealers who are more progressive than others and who have made special effort to bring their sales totals to normal, which has resulted in a very fair month, generally speaking. Sales of large machines have not been very satisfactory, but there have been a large number of the small portable models sold. Record business has been very fair and the demand for popular numbers has been especially lively. No doubt these popular selections are sold as a part of the equipment of the small table types which are to be taken away to Summer camps by purchasers.

Some dealers, taking advantage of the lull in business, are devoting their time to redecorating and renovating their stores so as to be better prepared to meet the expected large Fall and Winter business. This is time well spent and, no doubt, sales and business done in the Fall will more than justify the expenditure made by the dealer in rearranging his store at this time.

### Wins Sonora Jobber Contest

The Long Island Phonograph Co., Sonora jobber for this section, is being congratulated by the Sonora Co. and its many friends on the splendid showing it has made during the past year in the national Sonora sales campaign. Through the good work of everyone connected with the organization the sales total for the year has won for the company the honor of showing the greatest gain of any jobber based on the ratio of sales to the population of the territory which they cover. Every Sonora jobber in the country participated in this unique sales campaign, which started May, 1921, and ended May, 1922. As the Long Island Phonograph Co. is the youngest jobber on the list, the winning of this coveted prize is a signal honor and reflects the splendid work done during the past year. A handsome silver loving cup is to be presented to this organization for its great achievement. According to R. H. Keith, general manager of the Long Island Phonograph Co., no particular man in the organization is responsible, but every

## NOW IS THE TIME

MAKE YOUR PREPARATIONS NOW—NOT ONLY FOR YOUR SUMMER BUSINESS BUT FOR YOUR FALL TRADE.

DO NOT LET YOUR STOCK GET TOO LOW. YOU MAY REGRET IT.

WE LOOK FORWARD TO A LIVELY FALL AND WINTER TRADE.

BE PREPARED

# AMERICAN

## TALKING MACHINE CO.

BROOKLYN, N. Y.  
VICTOR WHOLESALERS



member played an important part in enabling this company to secure this enviable position among the Sonora jobbers. The members of this organization are: J. J. Schratzweiser, sales manager; Geo. A. Sheehan, credit and office manager; J. A. Keelan, dealer service manager, and Lee Coupe, who covers Long Island territory.

### Arell Phonograph Co. Enters Field

Among the latest additions to the retail trade in this section is that of the Arell Phonograph Co., Inc., which has just opened its new Victor establishment at 220 Utica avenue. A. J. Freeman, well known in talking machine circles in Greater New York, is the proprietor of this new store and is a man of long experience in the retail talking machine field. He was formerly with Bamberger's talking machine department in Newark, N. J., and also managed the talking machine shop conducted by Levy Bros., on Broadway. His experience covers a period of fifteen

years and he is well qualified to carry on this business successfully. The store is probably one of the finest-equipped in metropolitan New York, and no pains have been spared to equip it with every modern convenience for handling retail trade. Several private hearing rooms are a part of the equipment and a magnificently appointed reception room as one enters the store is a feature. The first impression of the customer as he enters is a lasting one, as the general scheme of decoration is one of harmony and welcome. Mr. Freeman is receiving the congratulations from a host of friends who are wishing him unlimited success in this new venture.

### R. W. Olsen & Co. to Move

R. W. Olsen & Co., well-known Victor dealers, who have conducted a successful retail business at 914 Flatbush avenue, are moving into larger and more commodious quarters at No. 904, a few doors below. These new quarters are modern in every respect, new booths and new service counters having been installed and, in general, equipped with the latest improvements in retail talking machine shops. This move was made necessary by the steadily increasing business of the company and this change is made at this time so as to be prepared for the expected increased business during the coming Fall and Winter months. As heretofore, the company is to feature the Victor line of machines and records exclusively.

### Victor Dealers Pushing Portable Models

The American Talking Machine Co., Victor wholesaler, is very enthusiastic over the progress made by its dealers in marketing the Victrola portable model. A special effort has been made to bring this high-class portable machine to the attention of many prospective buyers and the result has been that many of these machines already have been sold. The officials of this company are sparing no effort to co-operate with dealers to make the Summer business a prosperous one and are offering them a service that is bound to show results.

### Nassau Radio Co. Opens New Agencies

The Nassau Radio Co., distributor of John Firth & Co. radio products in Brooklyn and Long Island, reports that talking machine dealers are showing a keen interest in wireless products and that many new agencies are being opened up. Otto and Albert Ruckaber, who manage this business, are very enthusiastic and are making every effort to introduce John Firth products to talking machine dealers in this section. Although

WE offer our dealers a Service which is in keeping with the standards of "the Highest Class Talking Machine in the World."

THE INSTRUMENT OF QUALITY  
**Sonora**  
CLEAR AS A BELL



The bond between us and our dealers is "more than a business connection." It is said of us that we are "Suppliers to Satisfied Sonora Dealers."

*Any communication from you will have our prompt and careful attention.*

**Long Island Phonograph Co., Inc.**

*Sonora Distributors for Brooklyn and Long Island*

150 Montague Street, Brooklyn, N. Y. Telephone Main 4186



business has a tendency to be quiet at this time they state that work done now will bear fruit in the early Fall. Many dealers who have been interviewed have signed up with the provision that they will begin to carry stock on September 1. However, there has been a demand for complete radio sets and all indications are that many more complete units will be sold during the Summer months.

**Sterling Co. Absorbs Goetz Business**

An important event in talking machine circles in this section this month was the closing of negotiations by the Sterling Piano Co. for the purchase of the entire stock and lease of Goetz & Co., at 81 Court street, where the Sterling Co. will move its stock of pianos and talking machines and make its headquarters from now on. This move has been under consideration for some months past and a new location has been sought, but heretofore a desirable one could not be found and in order to procure an advantageous locality the company concluded arrangements whereby it secured the store and business of Goetz & Co. The two enterprises have been merged and the business will be conducted under the name of the Sterling Piano Co., Inc. The officers are: George U. Tompers, president and treasurer; Philip Ritzheimer, vice-president, and J. F. Smith, secretary.

The complete line of well-known makes of pianos and talking machines which have been featured in the past by both companies will be carried. The talking machine department, according to E. A. LeTure, manager, will be given a very fine position on the first floor, which will represent a decided improvement over the old location at the Fulton street store; where the talking machine department was located in the basement. Mr. LeTure is very keen about this new move and expects a substantial increase in business as a result. The Victor line will be featured.

**W. Ackerman Takes Over Getts Co.**

Another newcomer in the Brooklyn retail talking machine trade is William Ackerman, who has bought out the business of the Getts Piano Co., located at 698 Central avenue. Mr. Ackerman has been manager of this store for some time past and when the opportunity presented itself to purchase this business he immediately took advantage of it. The firm name is to be changed from the Getts Piano Co. to the Ackerman Music Store and Mr. Ackerman is in direct charge, as he has been heretofore. His long experience in retail circles in metropolitan New York qualifies him as one of the best retail salesmen in this section and his host of friends are congratulating him and wishing him unlimited success in his new business.

**Does Fine Sonora Business**

Manager A. G. Smith, of the Lafayette Music Shop, at 269 Kingston avenue, is being congratulated on the splendid showing in sales made during the month of June. The total receipts for this month were greater than those of May and greater than June of last year, a record which is an enviable one in every respect. Among the sales made during this month by Mr. Smith were two Chippendale DeLuxe Sonora models, which retail at \$450 each. In view of the fact that retail sales generally have been at a minimum this record is worthy of high commendation, but, as Mr. Smith stated, it is the result of a concentrated effort made by himself and his organization to make the month of June a record one if possible. Some newspaper advertising was re-

VICTOR  
RECORDS

## "STUMBLING"

To fill an order for the Victor record "Stumbling," or any other current success, without making at least one additional sale, is stumbling salesmanship.

The attention of every purchaser of popular records should be drawn to the wealth of material to be found in Victor Red Seal records.

VICTOR  
RECORDS

G. T. WILLIAMS CO. Inc.

217 DUFFIELD ST. ~ BROOKLYN, N.Y.

sorted to, but the principal work done was in the way of personal calls on prospective buyers, backed up by a very friendly personal letter.

**Brunswick Temple Adds Sonora**

The Brunswick Temple of Music, located at Kings Highway and Coney Island avenue, has just been appointed Sonora representative by the Long Island Phonograph Co., Sonora jobber in this territory. Milton Kramer, proprietor of this up-to-date shop, has successfully conducted the business for some time past and, with the addition of the Sonora line, is equipped to cater to all classes of trade. Heretofore Mr. Kramer has featured the Brunswick line exclusively. Recently Mr. Kramer took advantage of a moving picture which was being shown at the local theatre by placing a Brunswick phonograph in the lobby of the theatre, which played the record of the same name as the moving picture. This resulted in splendid publicity for his store and the Brunswick line.

**A. Lesser Remodeling Store**

A. Lesser, prominent Victor dealer, at 631 Sutter avenue, is taking advantage of the Summer months to renovate and redecorate his entire store. The general scheme of arrangement in the store is being changed and a new service counter and a specially designed record rack are being installed near the entrance to the store. Heretofore the record racks were in the rear, but the new arrangement will facilitate service and prove more efficient. A new window is also to be installed. When completed the store will present a very attractive appearance.

**Two Fine Sonora Sales**

A. Heilbronner & Sons, who conduct a store at Fifth avenue and Fifty-third street, made two fine sales this month, consisting of Sheraton period Sonoras, which retail at \$375 each. These two sales were the result of much active campaigning on the part of Ralph Heilbronner, manager of the business in the absence of his father,

A. Heilbronner, who is vacationing in Europe for the Summer months.

**A. Sklar Takes Over Sumner Store**

A. Sklar, of the Ralph Music Shop, 149 Ralph avenue, has taken over the entire stock and business of the Sumner Music Store, located at 268a Sumner avenue. Mr. Sklar conducts a thriving business at 149 Ralph avenue. He will continue the Sumner business at the present location, but will change the name to the Ralph Music Store. Mr. Sklar intends to take personal charge of this new business for the time being and intends to make several improvements that will make the store one of the finest in this section. The new store is to feature the Sonora line of machines in conjunction with other well-known makes. Sheet music and musical instruments will also be handled.

**RECORDING DEVICE FOR TELEPHONE**

Latest Contribution of Poulsen, of Telephone Fame, Supplemented by Invention of Nasarischwily—Records Telephone Messages

Bottling up a telephone message until the person rung up has returned to the office or house has become a possibility by the combination of an invention of Poulsen, the famous wireless telephone pioneer, and a wireless valve.

If a telephone call is made and the person wanted is not available a simple recording instrument can be set in motion and a message dictated that can be repeated at any time later.

The Poulsen telegraphone, invented many years ago and displayed, by the way, at an electrical exhibition in New York, is a device in which a telephone message can be impressed upon a moving steel ribbon by means of magnetic action. When the ribbon has run through a simple reproducing device it repeats the message but so feebly that the invention was abandoned.

An instrument has now been constructed by a man named A. Nasarischwily with which the reproduced sound can be amplified to any degree of loudness by the use of one of the valves now employed universally in wireless reception. The steel wire or ribbon, with its magnetic message, can be removed from the instrument and sent by post and the message reproduced in any other instrument and permanent records can be made of speeches and so on.

The inventor claims that a message or signal may be spoken from a train into a railway line and received by the engineer of the train directly following.

**\$3.25 Sample**  
With 10 inch Turntable  
and All Accessories

## MOTORS

2 SPRINGS

**\$3.25 Sample**  
With 10 inch Turntable  
and All Accessories

*We are the Exclusive Manufacturers of*

## THE MAGIC MOTORS

**Parts for These Motors Always on Hand—Also Tone Arms—Sound Boxes—Main Springs, Etc.**

**MAGIC PHONO SUPPLY CO., 261-273 Lorimer St., Brooklyn, N. Y.**

Telephone Stagg 1591



# CLEVELAND

*Dealers Going After Business—Co-operative Ad Campaign Effective—Window Displays Help—Announce New Agencies—The News*

CLEVELAND, O., July 10.—Advertising seems to be the outstanding feature in the talking machine trade here during the last month. Louis Meier, of the L. Meier & Sons Co., gained a great deal of favorable publicity when he gave a children's lawn party to 300 Cleveland youngsters on the spacious lawn which is located next to his establishment. Mr. Meier's daughter, Lillian, took charge of the affair and the little ones played games and danced while a large Victrola with an amplifier, placed on a truck, supplied the music. Passers-by gathered about the lot, and Mr. Meier received many requests for permission to use the truck in other parts of the city. Before the children left they were supplied with candy and balloons as favors.

#### Starts Co-operative Ad Campaign

The Eclipse Musical Co. has started a big co-operative advertising campaign, which is expected to make this Summer one of the biggest in the history of the talking machine. It is planned to send out suggestions for advertising, and material for the same to the dealers for direct distribution to the consumer. The Victor portable machine is the big feature of this campaign.

T. H. Towell, president of the Eclipse Musical Co., has created an article which will make the portable Victor machine one of the most popular sellers. It is a new leather cover and the big feature is that the cover is finished with a pocket that will contain twelve records.

According to Edward B. Lyons, general manager of the Eclipse, Mr. Towell thought of the cover when it was noticed that many consumers complained of the marring effect of weather on the finely finished surfaces of the portables. He experimented with a leather-like material and discovered that the appearance of the portable

might be improved and the attractiveness increased. Corners, handles, catches and other hardware on the exterior of the machines were removed, and the leather material applied with shellac. The hardware was then replaced, and a leather-cased machine resulted. The patent on this feature has been applied for.

#### Featuring Window Displays

Dealers in the city are doing advertising on their own account. The Euclid Music Co., on Superior avenue, has installed a Magnavox outside of its store which advertises the new records, and M. O. Mattlin, of the Home Piano Co., claims that a window display of Cheney phonographs has increased the sales of this establishment one hundredfold.

Window displays seem to be the most popular means of advertising. One of the outstanding windows of the month was that of the B. Dreher's Sons Co., created by William G. Bowie, manager of the talking machine department. The green Victor record books and pink pamphlets were arranged in checkerboard form on the window floor, with the well-known Victor dog on guard. It was possible to see this striking color scheme from different points in Play House Square, where the Dreher establishment is located.

#### Doing Well With Health Records

Manager Dan E. Baumbaugh, of the talking machine department in the May Co., is continuing his campaign on the Walter Camp health records and the Wallace reducing records. His latest step is a new pamphlet just issued, which announces special demonstrations and lectures on the Wallace reducing records, and arrangements are being made for four classes in weight reducing, which will be held in the private demonstra-

## ILSLEY'S GRAPHITE PHONO SPRING LUBRICANT

Ilsley's Lubricant makes the Motor make good. Is prepared in the proper consistency, will not run out, dry up, or become sticky or rancid. Remains in its original form indefinitely.

Put up in 1, 5, 10, 25 and 50-pound cans for dealers

This lubricant is also put up in 4-ounce cans to retail at 25 cents each under the trade name of

## EUREKA NOISELESS TALKING MACHINE LUBRICANT

Write for special proposition to jobbers

ILSLEY-DOUBLEDAY & CO., 229-231 Front St., New York

tion rooms of the May Co. talking machine department. Miss Jane Louis, who has charge of this division, is now on her vacation at Sedalia, Mo. On her way back to Cleveland she plans to stop at the Wallace Institute in Chicago, for further instruction in conducting the work here.

Much interest was aroused in local talking machine circles when the Arrow Phonograph Co. announced that it had just perfected a new lateral record. The completion process has been simplified and the result is claimed to represent a real forward step in record production. The right to manufacture the new record will be disposed of shortly.

#### Some New Cheney Dealers

Four significant accounts were closed by the Cheney Phonograph Sales Co. this month. These include the Buescher Co., the George E. Dales Music Co., Akron; the Andrewson Music Co., Dayton, and the Ampico Studio, Columbus. These are only a few of the new accounts being booked by jobbers serving this locality, the best indication of the trend of new business at this time.

#### To Extend Brunswick Territory

Plans for taking over the Buffalo territory and making it a definite part of the Cleveland district branch are being completed at the local Brunswick-Balke-Collender Co. branch headquarters, and it was expected that by the middle of July the new plan will be in operation.

#### New Concerns in the Field

The Home Piano Co. recently announced that it has opened a new store, the Globe Piano Co., in the Woodland-East Fifty-fifth section, and already the Vocalion Co., of Ohio, has designated the new store as retailer of the Vocalion records in Cleveland.

The Center Furniture Co., which opened a short time ago, will handle Sonora machines, according to latest announcements.

#### Pleased With Convention Visit

Victor jobbers from Cleveland who attended the recent convention at Atlantic City returned home with plenty of enthusiasm for their respective lines. Leaders in the industry in Cleveland who were at the meetings included George R. Madson, president of the Cheney Phonograph Sales Co.; Edward B. Lyons, general manager of the Eclipse Musical Co.; Howard J. Shartle, general manager of the Cleveland Talking Machine Co.; Miss Elsie Baer, manager of the M. O'Neil Co., Akron; Louis Meier, the L. Meier & Sons Co.; J. W. McNamara, of the Empire Phono Parts Co., and Dan E. Baumbaugh, manager of the May Co. talking machine department.

#### Two New Starr Phonographs

Two additions in the styles of machine have been made at the Starr Piano Co., according to D. G. Free, retail sales manager. One is a large machine called "Eighteen," made in both dark and light finish. The other is a small table machine, and is proving popular with purchasers.

#### Tie-up of Record and Photoplay

An interesting experiment of linking up the photoplay appearance and records of the same name was effectively made by the Remick Song Shoppe, when "Second Hand Rose" was tied up with the arrival of the film of the same name at the Cameraphone Theatre.

#### Meeting of Local Association

At the last meeting of the Cleveland Music Trade Association the following firms were represented: The H. B. Bruck & Sons Co., the Cheney Phonograph Sales Co., M. V. De Forest, the B. Dreher's Sons Co., Home Piano Co., the May Co., the Muehlhauser Bros.' Piano Co., G. M. Ott Piano Manufacturing Co., J. O. Raeder, Randolph House of Good Music and the A. B. Smith Piano Co.

## BANNER 50c. RECORDS

*Summertime—dancing-time  
—and the 50c. record!*

Summertime is dancing-time—country homes, lawn parties, beach parties, automobile parties! Everybody dances and everybody buys dance music!

But who buys the expensive dance records?

Surely not the man who knows where to buy the good popular priced records.

If he is near a BANNER RECORD dealer he knows that he can step in and buy full 75c. worth of record value for 50c. He knows that the tone quality is the same and that the record will last as long. He knows that the records are all famous stars "Broadway-known."

He knows this and he buys BANNER. He tells his friends and they, too, buy.

They all buy — continually. That explains why BANNER sells big the year round.

Write us today! We will send you complete details and samples.

**PLAZA MUSIC CO.**

18 West 20th Street

New York



# The Trade in PHILADELPHIA and LOCALITY

PHILADELPHIA, PA., July 8.—A rather unexpected, but very welcome, increase in the volume of business is reported by the majority of the talking machine and record dealers in Philadelphia for the week or ten days preceding the Fourth of July holidays.

The sudden spurt served to increase the optimistic outlook of the trade in general in this city regarding the Fall business, as the dealers admit that a pre-Fourth of July rush in business has not always proved to be the rule in the past except in those years when very prosperous times were ahead.

Therefore, they feel that they now have solid grounds upon which to base their general predictions that the Fall trade will prove to be exceptionally brisk and that the decline in business has passed. As a consequence all of the leading distributors are rounding up their forces to meet the heavy demands they anticipate from the dealers shortly.

Viewing the local talking machine and record business from every angle several of the leading distributors assert that the trade has a more healthy aspect at the present time than even they had hoped for a few months ago.

#### Believes in Canvassing

One of the dealers and distributors who believes that the business in the Fall will equal, if not exceed, previous records and who also believes that the best way to increase sales during comparatively dull times, such as the present is, by going out after the business in a vigorous fashion is H. W. Weymann, head of the well-known firm of H. A. Weymann & Son.

"Recently I have made a number of personal calls upon many of our Victor dealers to persuade them to put on outside canvassers for the purpose of boosting their business in Victor talking machines and records," said Mr. Weymann. "At first their objections to this course were based on the belief that it would not pay them to employ special canvassers during the Summer months. However, several of the dealers who decided to give my suggestion a trial have just reported that they have succeeded in selling a number of Victor machines of the portable type to families who will spend the Summer or their vacations at the seaside, in the country or in the mountains. "The sale of these small portable models, I know, will eventually lead to the purchase of more expensive cabinet models."

Mr. Weymann states that if all of the Weymann dealers will write to him, giving a list of the Victor records of which they have especially big stocks on hand the Weymann firm will give these records consideration when the list of records for the mid-month suggestion hanger is being made out, as this suggestion hanger is issued for the purpose of aiding the dealers in disposing of their surplus stock of Victor records.

#### Penn Co. Officials in New Offices

The officials of the Penn Phonograph Co. have just moved into their new offices, located on the second floor of the company's handsome building, at 913 Arch street, which was formerly used as a stockroom. The entire floor has been beautifully decorated and extensive alterations have been made during the past few months, until now the offices of T. W. Barnhill, the head of the Penn Phonograph Co., and those of his assistants and the general office force are undoubtedly among the most attractive that may be found in Philadelphia. The walls and ceilings of the new offices have been finished in a light cream color, which, combined with the many large plate-glass mirrors located decoratively in various parts of the second floor and the handsome indirect lighting fixtures, tend to give the offices a soft light that fills every corner.

Mr. Barnhill's personal offices are situated at

the front of the building with the side and rear partitions made up largely of plate-glass, so that he has absolute privacy as far as sound is concerned, but at the same time he is able to see everything that is going on in the rest of the offices. Next to Mr. Barnhill's offices is found the elevator entrance, with the telephone switchboard, next to which is located a large and handsome display room. Back of this comes the spacious reception room, while at the rear of the building are the general offices, where the clerks are to be found.

#### Reports Heavy Jump in Orders

F. B. Reinecke, manager of the Louis Buehn Co. sales force, at 835 Arch street, reports that he is very much pleased and surprised by the remarkably large sales made during the first week of this month. He attributes this unusual spurt in business to the fact that the Buehn dealers undoubtedly have made big sales of talking machines and records prior to the Fourth of July holidays, with the natural result that they at once gave orders to fill up their stock.

Louis Buehn and his family have recently moved into their Summer home at Ocean City, N. J. Mr. Buehn is commuting to his office three or four days each week.

The Victor Co. has just sent to Mr. Reinecke a sample of the new wrapping envelopes which will be issued soon as coverings for the Victor records. Prior to this time the Victor Co. has never made a wrapping envelope and consequently all Victor dealers will welcome this innovation. He expects a stock of these envelopes within a week and, owing to the fact that the Victor Co. purchases them in large quantities, they will be sold at a very low price to the dealers.

#### G. W. Hoover Believes in Action

G. W. Hoover, president of the Philadelphia Victor Dealers' Association, whose store is located at 1031 Chestnut street, is of the opinion that now is the time for all the talking machine dealers to concentrate their efforts upon the sale of the portable models, as during the Summer months people want light, durable and efficient machines to take with them during their vaca-

tions. Mr. Hoover points out that the time for selling the more elaborate models is during the rest of the year, when people are at home.

Mr. Hoover states that there will be no further meetings of the Victor Dealers' Association during the Summer months, but that their regular sessions will be resumed in the Fall, when he expects that many items of considerable importance will be brought up for consideration and action.

#### Auto Fleet for Edison Field Men

With the acquisition of a new Ford roadster, especially equipped, the Girard Phonograph Co., Edison distributor, has done away almost wholly with railroad fares as part of salesmen's traveling expenses.

P. R. Hawley, manager of this organization, has aimed for a long time to organize a fleet of automobiles for the use of his traveling representatives. As proof of his contention that traveling by auto enables the men in the field to strike many towns not reached by railroads and that it does away with the endless delays provoked by railroad schedules, the entire staff has demonstrated that it can now cover just three times the ground that it heretofore has and with better results.

The new car, like those already in service, is equipped with a phonograph and a generous supply of re-creations. This affords the salesman an excellent opportunity to demonstrate the phonograph anywhere and at any time and it is no unusual sight in small towns to see one of these cars in front of a prospective dealer's store, with dozens of the townspeople standing about enjoying a midday concert.

#### Columbia Grafonola Dealers' Association Meets

The June meeting of the Columbia Grafonola Dealers' Association of Philadelphia was held on the 27th at the Hotel Adelphi. The entertainment and publicity committees submitted various reports for the meetings of the Columbia dealers to be held in Philadelphia this Fall and further details regarding these meetings will be presented to the members at the July session. A special drive for membership will be inaugu-

(Continued on page 84)

## On Guard



Penn-Victor Dogs are the best watchmen of Victor Welfare in the Home.

Sold by most Victor Distributors.  
Write them or us for prices.

## Penn Phonograph Company

913 Arch Street

Philadelphia, Pa.

Victor Wholesale Only



THE TRADE IN PHILADELPHIA AND LOCALITY—(Continued from page 83)

**H. A. WEYMANN & SON, Inc.**  
 1108 Chestnut Street Philadelphia, Pa.  
**VICTOR WHOLESALERS**

Q. R. S. PLAYER ROLLS  
 WEYMANN "KEYSTONE STATE" STRING INSTRUMENTS

**YOUR BUSINESS  
 and OUR BUSINESS**  
 are very much the same, "Mr. Victor  
 Retailer. We have the common pur-  
 pose of increasing Victor merchan-  
 dise sales. Getting together  
 will prove mutually  
 advantageous

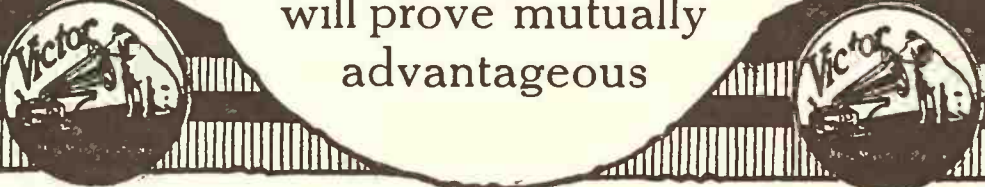

rated before the next meeting and it is expected that this drive will produce substantial results.

George Ross, of the Ross Frankford Music Store, supplied the music for the races at the Frankford Driving Club Race Track, with a Columbia Grafonola and Columbia records in conjunction with a Magnavox. The music made such a hit that Mr. Ross secured several Grafonola prospects, including two of the judges.

#### W. C. Stiver, Jr., Undergoes Operation

William C. Stiver, Jr., field representative for the Girard Phonograph Co., local Edison distributor, has just recovered from an operation which took place a few weeks ago.

Having been formerly identified with the W. C. Stiver Co., Edison dealer in this city, and enjoying the acquaintance of practically every Edison dealer in the local territory, Mr. Stiver had the personal good wishes of the entire Edison trade during his illness.

#### Interesting Vocalion Records

The Lincoln Business Bureau, 1011 Race street, of which B. H. Rogers is the manager, and which is the local distributor for the Vocalion phono-

graphs and Red records, has just issued a new list of twenty-four double-face records that have just been placed on the market. Included among these records is one that features a melody that is more than 200 years old. In telling of this record and the others on the list, Mr. Rogers said:

"A distinctly new art has been developed in the composition of the music settings for phonograph recording. Songs are not recorded 'as is' any longer. In fact, the Vocalion always strives to introduce appropriate pieces of musical scenery of a descriptive character that add materially to the effect of the whole composition."

#### Open Attractive Columbia Store

The South Ninth Street Talking Machine Shop has opened up a very attractive Columbia store at 903 South Ninth street. The owners of the store, Antonio Gallo and Joseph Caroley, are very enthusiastic regarding the possibilities for Columbia business and have arranged for an important advertising campaign.

#### Reports Encouraging Conditions

The Talking Machine Co., Victor distributor, reports an increased demand from its dealers during the last two weeks of June, which has continued to manifest itself thus far in July. Good Fall business is looked forward to.

#### G. W. Witney Tells of Heppe Activity

George W. Witney, manager of the C. J. Heppe & Son's store, tells of numerous sales within the last few weeks of the portable outing models of the Victor machines, which, he says, seem to be increasing in popularity with the general public by leaps and bounds.

#### Conditions With Weymann

H. W. Weymann, of H. A. Weymann & Son, is commuting each day between the Quaker City and Atlantic City, where he is spending the Summer months with his family at one of the well-known hotels. He says that fully 50 per cent of the Weymann dealers have placed their advance orders for Victrolas for September, October, November and December, and from this fact he declares that it is apparent that these dealers seem to hold his views to the effect that the

Fall trade will establish new records and that in accordance with this optimistic outlook the dealers wish to be prepared to meet the demands of their customers and consequently are placing their orders now so that they "will not be caught napping."

#### Enlarged Quarters for Stern & Co.

Stern & Co. have just completed an addition of 10,000 square feet to the second floor of their building at 712 Market street. The Columbia department, which is located on the second floor, is included in the improvement and plans are being made for an active Fall trade. This is a Unico-equipped department throughout, which, naturally, made rearrangement and enlargement easily accomplished. The department is under the management of Miss Frances J. Eastbrom.

#### HAWLEY ADDRESSES KIWANIS CLUB

Manager of Girard Phonograph Co., Edison Distributor, Pictures Life of Edison

ALLENTOWN, PA., July 3.—Unusual interest surrounded the regular noonday luncheon of the Kiwanis Club here recently, when P. R. Hawley, manager of the Girard Phonograph Co., Philadelphia, Edison distributor, gave the members a verbal picture of the life of Thomas A. Edison and of the invention of the phonograph.

W. J. Flach, secretary and treasurer of the Yeager Store, Inc., Edison dealer, was chairman of the luncheon and introduced Mr. Hawley, who had been invited to visit Allentown especially for the occasion. Following the address Albert Schantz, a violinist well known in Coopersburg, entertained the members with several numbers, including a tone test with the phonograph, which was generously applauded.

Both the Allentown newspapers gave space to the address in full and expressed the belief that the renewed interest in the phonograph engendered by the affair would prove an added stimulus to the trade in that community.

#### MUSIC MASTER HORN POPULAR

Product of General Radio Corp., Philadelphia, of Great Acoustic Merit—Also Handles Radio Parts and Equipment—New Dealers Added

PHILADELPHIA, PA., July 5.—The Music Master horn, announced by the General Radio Corp., of this city, last month, has met with much popularity among the talking machine dealers carrying radio equipment. Mr. Eckhardt points particularly to its laminated wood construction as the best suitable means for magnifying sound naturally. It is claimed that this horn produces an exceptional volume of sound and at the same time retains the true tonal quality of the singer, the full richness and accurate shadings of expression. Mr. Eckhardt stated that the Music Master horn has the advantage of being a tested, fully proved invention, having been fully accepted in the difficult requirements of talking machine circles. These horns, attractively built and finished, are planned in two sizes, twenty-one-inch for concert work and fourteen-inch for the home.

The General Radio Corp. is also the producer of the "Geraco" line of radio parts and equipment. Mr. Eckhardt states that a number of new dealers have been added to its list.

## Stimulates Talking Machine Business! The PHONO-TONER

TRADE MARK  
(Registered in U. S. Patent Office)

**Renders softer, sweeter music and  
reduces surface noise.**

You cannot find a more satisfactory  
answer to that oft repeated objection  
—"Too much surface noise."

**Retails for 35c. and 50c.**

Regular Trade Discounts.

The Phono-Toner (actual size)



**ThePhonotone Co.**  
310 Lincoln Building  
PHILADELPHIA, PA.



Forms handle  
for needle set-  
screw.

## Italian Music Rolls

Largest collection of Italian and other foreign music rolls in the United States. Catalogs and discounts on application.

UNITED MUSIC STORES

619 Cherry Street  
225 W. Mulberry St.

Philadelphia, Pa.  
Baltimore, Md.

## DECALCOMANIA

Name Plates for Talking  
Machines, Pianos, etc.

High Class Workmanship

Write us for further information

**National Decalcomania Co.**  
220-230 N. 60th St., Philadelphia, Pa.



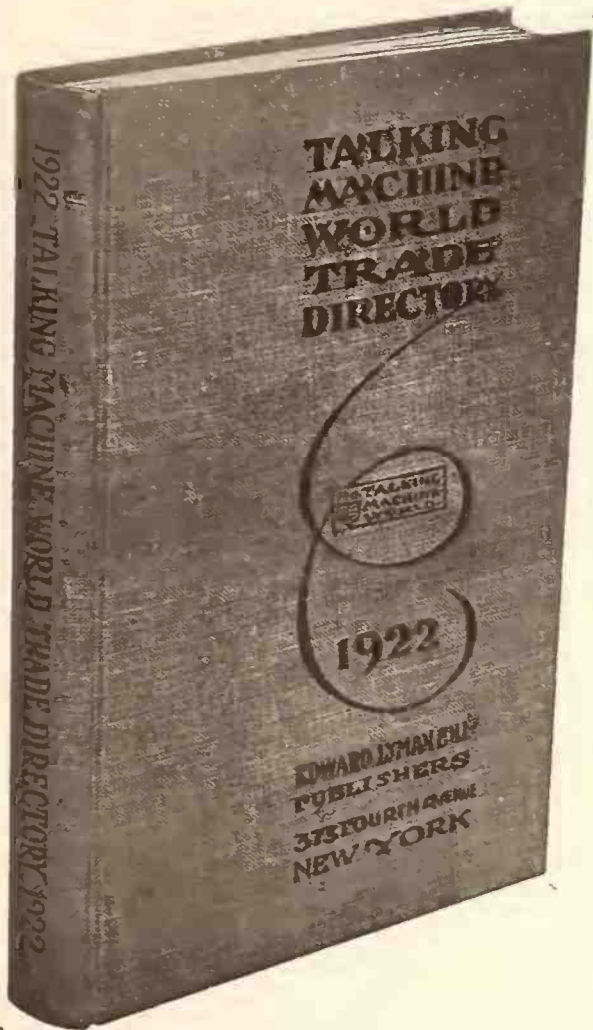

# Only 50 Cents

The Talking Machine World Trade Directory has filled a long standing want of the industry. It is kept as a handy reference volume on the desks of a large number of the members of the talking machine industry where, in an instant, it provides detailed knowledge about this or that company and the products made by each company.

It gives the kind of information it would otherwise consume much time to secure. For instance, it will give you a complete up-to-date list of the manufacturers and jobbers who comprise the talking machine industry, including the invaluable data about each concern, such as location of factories, names of officers, location of branch offices, trade names controlled, policy of marketing product, etc., etc.

## HERE IS WHAT SUBSCRIBERS SAY:

"Your 1922 Model Talking Machine World Trade Directory reached us all right, and the writer went over it carefully yesterday at his home, and we wish to compliment you. There has never been a Trade Directory got up that has been so accurate as regards firms listed and that has covered the field so thoroughly.

"There is no question but that this Directory will prove of real, tangible benefit, not only to its advertisers and those who are listed in same, but to the general dealer trade at large, who have needed a directory of just this nature."

"We congratulate you on the appearance of The Talking Machine World Trade Directory and trust that you will make it a yearly feature of your business.

"We could use two more copies of this publication in our organization to great advantage, therefore request that you send them to us, proper billing.

"Just before closing wish to state that we consider the move on your part of issuing a directory of the talking machine industry as being one of the most forward movements occurring in the industry for several years."

Only 50 Cents

Only 50 Cents

**USE THIS  
COUPON NOW**

Send Stamps or Check



EDWARD LYMAN BILL, Inc.,  
373 Fourth Ave., New York City.

Gentlemen:

Please send me postage prepaid a copy of the 1922 edition of The Talking Machine World Trade Directory, in payment for which I enclose 50 cents.

Name .....

Firm .....

Street .....

City and State .....



# HOT LIPS

The New "Wang Wang Blues"  
by the same Writer.

"You can't go wrong  
With any FEIST song"

HEAR IT NOW!

He's got hot lips — When he plays Jazz, — He draws out steps.



### BUEGELEISEN & JACOBSON CATALOG

New Edition Admirably Produced With Great Line of Musical Instruments That Make Wide Appeal—Many New Lines Added

Buegeleisen & Jacobson, importers and wholesalers of musical merchandise, New York City, have just presented to the trade their 1922 catalog, known as No. 120. The new edition is up-to-the-minute in every detail and contains within its covers an exceptionally wide variety of salable musical merchandise from the various markets of the world. Although larger in scope, the 1922 catalog has been compiled with less number of pages. This has been accomplished by reducing the number of illustrations. Those left, however, show complete details and give the dealer all the required information for making his selection. Many new lines have been added and improvements made where possible. The numbers shown have been carefully selected and criticized by both the buyers and sales staff, who are intimately familiar with the wants of the trade.

The merchandise listed is of such standard makes as Lester, Monarch and Salanti accordions, Duss band harmonicas, Durro & Durro Master violins, bows, strings and accessories and the S. S. Stewart line. Particular attention is directed in the catalog to the Automat showcases, which are described therein. Buegeleisen & Jacobson report that their many dealers have found these showcases of invaluable assistance in the handling of sundries and strings, and that

they enable them to carry a small but complete line in a very limited space. Attention is called to the probable increased tariff on imported musical merchandise and its corresponding effect on the cost of these instruments. The company hopes, however, that the prices on domestic lines will remain stable, although the contemplated change in the tariff might have some effect.

### INVENTS NEW RECORD FILE

W. H. Snyder, Long Island City, N. Y., is the inventor of a new device for filing records, which will be known as the "Recordpark." A company is now being formed to manufacture and market this new filing device, which embodies several distinctive features. The "Recordpark" is built on the principle known as the "compression-expansion" method of storage, whereby records are supported and adjusted under pressure between plates, with means for expanding the capacity.

### COMBINED RADIO AND TALKER

The Concertola Corp., of New York City, which is the jobber for the National line of talking machines, is placing on the market a combined radio and talking machine within one console cabinet. It is expected that production will shortly be obtained and the new addition to the line will be marketed in an energetic manner.

L. K. Tipton, Victor dealer at 506 East Grand avenue, Beloit, Wis., has discontinued business.

### AN ATTRACTIVE OHIO STORE

Establishment of Chas. M. Zitzer in Mansfield Most Modern in Every Particular

MANSFIELD, O., July 5.—There are many very handsome talking machine stores in the State of Ohio, stores upon which have been spent much time and money, but one of the most attractive of the lot, according to talking machine men who know, is that of Charles M. Zitzer,



Interior of Zitzer's Handsome Store

well-known Victor dealer in this city. The equipment of the Zitzer store is most modern in every particular, as is indicated by the accompanying illustration. The entire arrangement has been highly praised by traveling men, among them F. L. Fritchey, of the Perry B. Whitsit Co., who has an opportunity to study the arrangement of many establishments.

### KEEPING IN TOUCH WITH THE TRADE

The Wall-Kane Needle Mfg. Co., Brooklyn, N. Y., manufacturer of the semi-permanent needle of that name, reports satisfactory business. The executives of this concern are strong believers in keeping in close touch with the trade and are energetically going after business. B. Cohen, brother of the president of the company, is on the road in the interest of the Wall-Kane needle and has now reached as far as the Pacific Coast. Mr. Cohen reports that conditions on the Coast are good and is attesting this through the orders he is sending in.

S. Kaminshine returned from a trip through Canada with optimistic reports of present and future conditions in the Dominion.

N. Cohen, president of the company, left recently for a trip embracing the principal cities in Canada.

L. G. Evans, of 225 West King street, Lancaster, Pa., has leased a store in that city, which he will open as a talking machine and musical instrument business in the near future.

The West Piano Co., dealer in talking machines and pianos, of Moorhead, Minn., is remodeling and enlarging its store.

## "Musical Merchandise Sales Are Keeping Us Going—"

That's what a customer from up-state tells us.

He has found his Small Goods department a life-saver. The brisk business he's been doing in the smaller instruments and accessories has kept down overhead, brought new customers into his store (every one of them a phonograph prospect) *and paid profits!*

And Musical Merchandise can do the same for YOUR Store.

Send for our new illustrated Catalog and our Confidential Trade Price List No. 4. These two FREE books make Musical Merchandise buying easy—successful.

**THE FRED. GRETSCH MFG. CO.**

*Musical Instrument Makers*

60 BROADWAY

Since 1883

BROOKLYN, N. Y.



# LOS ANGELES

Portable Machines Lead Demand—New Columbia Store—Prominent Visitors—Sherman, Clay & Co. to Move—Trade Activities

LOS ANGELES, CAL., July 1.—Sales of talking machines during the month of June seemed to show a slight slackening, although, according to a number of reports, business from departments at least equaled and, in many cases, exceeded that of the corresponding period of last year. The jobbers and distributors generally report their sales to be above anticipation.

#### Southern California Association Honored

A letter has been received from C. L. Dennis, secretary of the National Association of Music Merchants, which was addressed to Secretary Farquharson, of the Music Trades Association of Southern California, announcing that the National Association banner for organized effort had been awarded to the Southern California Association. The banner is being properly inscribed and will be officially presented at the July general meeting.

#### Sherman, Clay President in Town

The Victor dealers of Los Angeles were greatly pleased to receive a visit from Philip Clay, president of Sherman, Clay & Co., during the last week in June. Mr. Clay had just returned from the jobbers' convention in Atlantic City and returned by way of Los Angeles, where, accompanied by the genial Charlie Ruggles, Los Angeles manager, he made a number of calls on the trade.

#### Motion Picture People Keen for Portables

W. H. Richardson, president of Richardson's, Inc., reports the sale of Victor portables to Gloria Swanson, Paramount star, and to Tom Moore, famous Goldwyn artist. Richardson's has sold quite a number of portables to motion picture people, who use them when "out on location" as well as for their own private use. The Motion Picture Directors' Association also recently bought a beautiful console or period model phonograph from Richardson's, which they installed in their club house.

#### Columbia Field Sales Manager in Los Angeles

Robert Porter, field sales manager of the Columbia Graphophone Co., spent several days in Los Angeles last month, where he held a number of salesmen's meetings and visited the trade in the city as well as out of town.

#### New Columbia Store in San Bernardino

R. L. Tamplin, owner of the Columbia Stores Co., operating an exclusive Columbia store in San Diego, which has been extremely successful during the eight months it has been established, has opened a second store at San Bernardino, which he calls "The Store Beautiful." The general design is patterned after the main store in San Diego, with the decorating scheme somewhat different. Following the same plan inaugurated in his San Diego store, Mr. Tamplin will handle Columbia products exclusively in San Bernardino, and he states that this is number two of a chain of stores which he intends establishing throughout southern California.

#### Dupont Takes on Columbia Line

Thomas Dupont has opened a new exclusive Columbia establishment at 854 South Hill street. He had been handling several lines of phonographs at another location, but on moving to his new store decided to handle the Columbia line exclusively.

#### Robert F. Porter a Visitor

Robert F. Porter, field sales manager of the Columbia Graphophone Co., paid a visit to this city a

few weeks ago on a tour of inspection of the Pacific Coast branches. While in this territory he called on all of the Columbia dealers, giving them the benefit of his experience and knowledge in the general merchandising field.

#### Swanson Portable Great Success

R. W. Moon, sales manager of the Swanson Co., Los Angeles, has made a phenomenally fine sales record with the Swanson portable phonograph on the Pacific Coast. Between March 10 of the present year and the first week of June he sold over 100,000 of these home and vacation joy bringers. Mr. Moon left for Chicago last month and was forming plans to take over the distribution of the Swanson throughout the entire country.

#### Blue Bird Man Comes South

After spending several weeks in San Francisco and in the northern part of the State I. S. Lessor, special representative of the Blue Bird Talking Machine Co., returned to Los Angeles for a few days last month. He reported that he had been devoting a good deal of time to the radio supply business and had secured several thousand dollars' worth of orders for cabinets for the Radio Supply Co., which is affiliated with the Blue Bird Talking Machine Co.

#### Sherman, Clay & Co. Move

Sherman, Clay & Co., Victor distributors, are having a new building specially erected for them, at the corner of Tenth and Santee streets. Unfortunately this building is not yet completed and their lease in Parmelee Dohrmann Building having expired and their old quarters being urgently needed by the owners, it became necessary to obtain temporary headquarters with the Wood Mfg. Co. Manager Ruggles reports that, in spite of the inconvenience caused, service to Victor dealers has been uninterrupted and no complaints have been received.

#### Good Results From Campaign

The Eastern Outfitting Co., of this city, which opened its first selected dealers' Grafonola newspaper advertising campaign last month, has completed the campaign and reports the sale of 250 instruments as a direct result of this drive. The company is delighted with the success of the campaign, which was far beyond all expectations. This enterprising dealer recently added an automobile truck to its delivery service for the exclusive use of the Grafonola department, a novel feature of the truck being the fact that there is painted in colors on each side a reproduction of the illustration used on the front cover of the Columbia record supplement in February, 1922.

#### Los Angeles Salesman Goes to Seattle

C. H. Meurs, who is known very well in Los Angeles, where he had been employed in several phonograph departments as a salesman, left here for Seattle last month to fill a position with the Bush & Lane Piano Co. Mr. Meurs, in addition to being an excellent salesman, is an enthusiast in music and grand opera.

#### George W. Lyle in Los Angeles

George W. Lyle, president of the Manufacturers' Phonograph Corp., spent several days in Los Angeles last month and was met by Walter S. Gray, of the Walter S. Gray Co., of San Francisco. Mr. Lyle, who has many friends in the trade on the Pacific Coast, reported excellent sales of the Strand phonograph, both in Los Angeles and in the East.

#### SUGG & ROUNTREE BUILDING STORE

KINSTON, N. C., July 8.—Sugg & Rountree, of this city, dealers in musical instruments, including talking machines, are erecting a new store in order to facilitate the handling of their increased business. The company also plans to increase its stock as soon as the new establishment is completed.

## Every Sale Counts This Time of Year

There is a good steady profit to be made during the summer months by displaying and featuring Sonora Semi-Permanent Needles. They are easy sellers because the Sonora name is on every package and because they are the *ideal* needles for dancing.

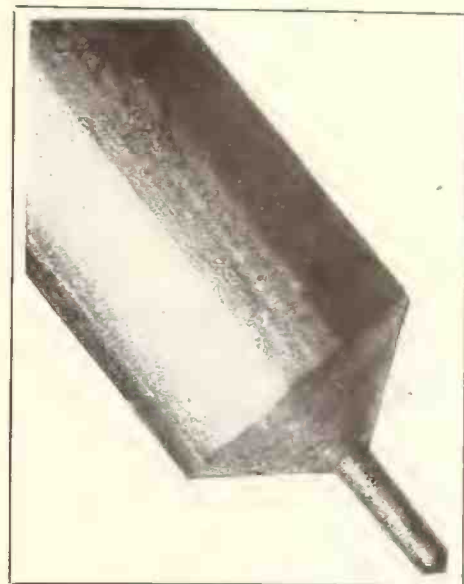

THE INSTRUMENT OF QUALITY  
**Sonora**  
CLEAR AS A BELL

## Semi-Permanent NEEDLES

Note the long, uniform shaft on the needle point magnified above. That is what makes it possible to play fifty or more records with these needles, with the minimum of wear on the record.

Send in your order today and boost your July and August profits.

**CAUTION!** Beware of similarly constructed needles of inferior quality.

**Sonora Phonograph Company, Inc.**

GEORGE E. BRIGHTSON  
President

279 Broadway New York

Canadian Distributors:  
I. Montagnes & Co., Toronto

## MOTORS

(Swiss)

### DOUBLE SPRING

Suitable for Portable Phonographs

Stock On Hand, Ready For Delivery

Sample \$3.75—Write for One

**MERMOD & CO.,** 874 Broadway  
N. Y.



# NEW ORLEANS

*Effective Advertising Stimulates Sales of Machines—Satisfactory Upward Trend in Business During June—Month's News*

NEW ORLEANS, LA., July 5.—A general improvement has been experienced throughout the music trade during the month of June. Nearly all dealers report a much better month than May and some state that the past month was better than June, 1921. It remained, however, for the out-of-town salesmen to report the prize sales of the month.

The success of the two projects has in both instances been attributed to well-planned and organized advertising. The first took place in Brewton, Ala., where the Hainje Specialty Co. sold, in less than eight weeks, one hundred and thirty-two Grafonolas, one carload, and the drive is not over yet. J. A. Hainje, president and manager of the firm, has branch stores at Atmore

and Century, which are also working hard in the campaign. His record sales have been correspondingly as large.

Down in Biloxi, Miss., J. A. Abrams, who ran two full pages and six half-page ads in the Daily Herald on Tuesdays and Fridays from May 20 to June 9, reports the following result: "Thirty-four Columbia instruments, ranging in price from \$60 to \$175, were sold. The down payments received were \$417.25 and about two hundred inquiries from various parts of this section were received from people whom we hope to sell later on. This was during our duldest months."

Mrs. Trembley, at the Dugan Piano Co., reports a much improved trade, though they have not pushed the advertising as much as in the earlier months.

"The people seem to be freer with their money now that the danger of the flood is over and cases of unemployment have become fewer among the solicited public," said Mrs. Trembley. "The horizontal model has been our best seller, but our record sales show a big increase within

the past month. This is due partly to the Wallace Reducing Record, which Dugan is featuring now, and partly to the noted increase in demand for popular music."

At Werlein's Manager Powell agrees that there has been an improvement in buying and states that he has received his share and that the salesmen are kept in a stream of perspiration all the time answering questions put to them by the many buyers. The portable model has been the feature of the selling. Everyone seems to want a Portable to take away with him during the Summer and the demand shows no sign of abatement. Lucille Hawley is the latest addition to the sales force of this establishment.

Ralph Young, sales manager of Grunewald, has found the mahogany Victor cased portable his biggest seller and popular records going like hot cakes. Cash sales have been fine.

Over at the Edison Co. things have been rather quiet during the past month in spite of the new models that have come out. However, sales are not below normal for this season of the year and a good Fall business is looked for there.

A. Sparrow, head of the Southern district of the Columbia Co., reports business in the northern part of Louisiana as booming. He has just opened three new accounts up there. The territory is also good, but the northern part of Mississippi is quiet.

## THE PORTABLOOP

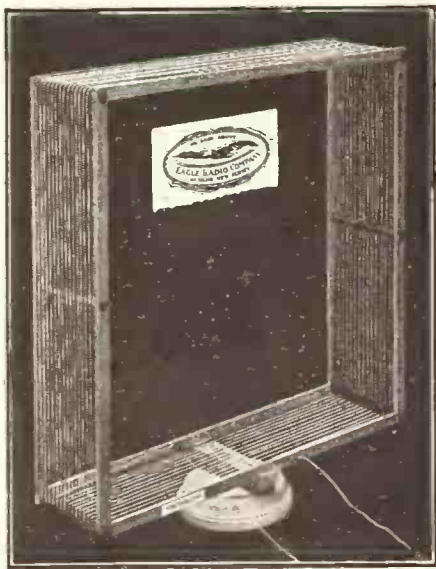

The logical antenna for congested districts, offices and apartments

List Price  
**\$10.00**

Order a sample now



210 Central Avenue

## REPAIRS

TALKING MACHINE TROUBLES AND HOW TO REMEDY THEM

Conducted by Andrew H. Dodin

Getting Volume From a Portable

Englewood, N. J., June 15, 1922.

Andrew H. Dodin,

Talking Machine World, New York.

Dear Sir: I have a portable machine and cannot seem to get any volume of sound from it, even with an extra loud needle. This machine has a horn on the left side of the cabinet extending to the front. Do you think, if I rebuilt this cabinet with a horn constructed on the style of the Victor portable, that I would get better results? If so, what wood would you suggest using for the horn part? (Signed) T. Sansone, Englewood, N. J.

Answer: Nearly all the portable machines on the market that are constructed with a side horn lack both volume and quality of tone. The chief reason of this is in the fact that there is hardly any semblance of a horn in the machine, a piece of thin board is merely curved around the motor, a small block of wood, cut at an angle, is glued just underneath the tone arm opening (on the bottom of the cabinet), presumably for the sound to strike and be forced to the front of the cabinet. The material that these makeshift horns are made of, combined with their shape and size, naturally prevents good results.

If you have carefully examined the Victor portable you will find that the idea of the cast-iron horn elbow and wood bell used in all Victrolas is carried out on a smaller scale in this model. The top lid of the machine also adds to the volume of tone, for the sound, after leaving the horn, is reflected by the lid and its fine varnished surface is no doubt a factor in the surprisingly good results obtained.

If you could reconstruct your machine in such a way as to make use of the lid as a reflector—first lining it with oak or spruce, well varnished and rubbed smooth—I am sure that you would get good results.

As to the wood for the horn, oak, spruce or mahogany are all worth trying.

Correcting Motor Slipping

Ilion, N. Y., June 24, 1922.

Talking Machine World, New York.

Gentlemen: Can you advise me, through your repair column, how I can stop the following trouble in my Columbia machine? This is a machine with a three-spring motor and it seems that

after playing about one-half of a record the pitch of the tone will change and keep going up and down the scale for some time, when it will stop and run along all right. I have had the motor apart, graphited the main springs and oiled all parts thoroughly, but cannot seem to stop the trouble. Could it be caused by one of the gears being badly worn? Your help would be appreciated. (Signed) P. J. Conway.

Answer: Your trouble is one that is often met with. It is entirely in the governor of the machine and the governor friction pads (the two little felt pads that act as a check on the speed of the governor). I would take the governor apart, clean the governor shaft with emery cloth until it is absolutely smooth and bright, try it in the governor disc, see that it will work freely without sticking at any spot. Assemble the balls and springs in their correct position, being sure that the governor springs are all of the same shape so that one would not have a greater tension or pull than the other. The governor balls must be firmly attached to the springs.

Replace the governor in the motor. Now take the friction pad frame and remove the little felt pads and see if there is a hard spot on the surfaces which rub against the governor disc. In case there is, cut a thin slice of the pad off with an old razor blade. Soak the pads well in oil, replace in the frame, being sure to have them held tight by the little clamps or fingers of the frame, then place the frame into position in the motor. It will probably be necessary to re-set your speed indicator, inasmuch as you have changed the position of the felt pads.

You will find that if you go over these points very carefully that the trouble will be cured, and can be prevented in the future by more frequent oiling of the felt pads, which will prevent a hard spot forming on them.



No. 35767/10 Palm Plant, natural prepared, everlasting in green.

My SEASONABLE CATALOGUE No. 35 containing illustrations in colors of Artificial Flowers, Plants, Vines, Garlands, Hanging Baskets, etc., will be MAILED FREE ON REQUEST.

	Inches High	Palm Leaves	With Pot	Without Pot
35767/24	24	10	\$1.50	\$1.00
35767/5	30	5	1.00	.75
35767/7	42	7	2.00	1.50
35767/10	48	10	2.50	2.00

**FRANK NETSCHERT**  
61 BARCLAY ST. NEW YORK, N. Y.



# WALTER CAMP'S DAILY DOZEN

**NOT AN EXPERIMENT, BUT A PROVEN SUCCESS**



WALTER CAMP

An imitation "twelve" can never equal the DAILY DOZEN, because any system of physical culture exercise records cannot possibly be any greater than the man who conceives or directs them.

Walter Camp is recognized internationally as America's foremost athletic authority. His system, known as the DAILY DOZEN, has been universally accepted as the acme of perfection in physical culture exercise.

Dealers handling Walter Camp's DAILY DOZEN on HEALTH BUILDERS records have the satisfaction of knowing that they represent the original and best obtainable system of exercise records on the market.

HEALTH BUILDERS' national advertising has educated the public to look for Walter Camp's signature before buying physical exercise records. None genuine without Walter Camp's signature.

*Write us today for sample and full information*

## HEALTH BUILDERS

DEPARTMENT W7

334 FIFTH AVENUE

NEW YORK, N. Y.





When the mountain wouldn't come to Mahomet, Mahomet went to the mountain. Get your truck in action, put a Grafonola aboard and a stock of records and go get 'em. Your Dealer Service Man can furnish a large facsimile Columbia Record sign for display; a weather-proof, padded cover for the Grafonola; a special rack so records will ride safely.

Columbia Graphophone Co.  
NEW YORK

## SAN FRANCISCO

*Increased Business Follows Shriner Conclave—Strong Demand for Portable Models—Magnavox Co. Enlarging Plant—The News*

SAN FRANCISCO, CAL., July 5.—As a result of the National Shriner Conclave in San Francisco this month there has arisen a great deal of discussion among the retailers as to the benefits of conventions and carnivals to the merchant. During Shriner Week retail business was almost at a standstill. Everybody was too busy enjoying himself to think of buying. The visitors, of course, patronized the hotels and restaurants and bought souvenirs of all sorts, but they did very little in the way of stimulating business in general. Chinatown did a rushing business. But the good from conventions usually comes after the events have passed. Every visitor to the Pacific Coast in a measure becomes a missionary and the ultimate effect is that the stream of new settlers to the Coast is kept flowing. New settlers are what the Coast wants; new citizens are a permanent asset. The money spent entertaining visitors is well spent and undoubtedly the business man who stays with the game will profit. The week after the Shriner convention retail business showed a marked increase and business has been very fair since. More money is in circulation and the talking machine dealers are getting a share along with the rest.

The demand for portable talking machines is splendid this season, and record business is good. Medium-priced machines are also moving pretty well, but the expensive models are lagging for the moment. Radio interest has not yet reached the peak, apparently, and broadcasting programs of high merit are featured for almost every half hour of the day and evening.

As a result of the broadcasting of operatic selections in connection with the recent grand opera season at the Stanford Stadium at Palo Alto, the demand for Martinelli records and other classics was much increased in San Francisco and vicinity. Martinelli was the star tenor of the Stanford opera company, which gave a series of wonderful performances in the open air and which drew audiences of vast numbers.

The Magnavox Co. is enlarging its manufacturing plant in Oakland and when the improve-

ments are completed the capacity of the factory will be at least doubled. The demand for the loud speaker is growing fast day by day on account of its value in radio concerts. The plant of the Magnavox Co. is situated on the outskirts of Oakland in the midst of beautifully laid out grounds and flower gardens.

C. T. Compton, acting manager of the Phonograph Shop on Stockton street, is spending a three weeks' vacation with his family party at the Yosemite Valley. The party has an automobile camping outfit, including a portable Sonora phonograph. A very attractive show window of the Phonograph Shop is devoted to a display of an ideal camping outfit in which a portable phonograph is prominently featured. Bent Davies, who represents the Sonora Co. in southern California, is taking Mr. Compton's place in his absence.

John Foster, manager of the San Francisco store of the Rudolph Wurlitzer Co., has been transferred to the new store of the company in Los Angeles.

Clark Wise, of San Francisco, and Mrs. Wise leave this week for a short vacation at Napa Soda Springs. Mr. Wise, who is a Shriner, says business after the convention picked up pretty well, though he regrets the shortage of portable Victor machines, which is somewhat of a handicap at this time.

Mr. Abrams, manager of the wholesale and retail phonograph department of Kohler & Chase, is taking a trip down the San Joaquin Valley in the interests of Burnham machines and Okeh records.

Mr. Corcoran, manager of the San Francisco wholesale department of the Brunswick Co., has been calling on the trade in the Sacramento Valley. He says business was quiet in Sacramento during the big Forty-niner carnival.

Frank Crumb, of Marysville, one of the most successful dealers handling the Brunswick line exclusively in California, is installing several additional booths in his store. Business is satisfactory in northern California.

C. L. Hemphill, vice-president of the Commer-

cial Investment Trust Co., of New York, which firm is largely interested in financing Brunswick dealers, has just paid a business visit to San Francisco.

Louis Schroeder, manager of the talking machine department of the John Breuner Co., Sacramento, is spending his Summer vacation with his home folks in Oakland, together with his newly acquired bride.

J. J. Black, of the Wiley B. Allen Co., has gone to the Hawaiian Islands with the Shriner expedition. All the stores of the Wiley B. Allen Co. on the Coast close this Summer from June 17 to July 29 at noon on Saturdays.

The new phonograph department of the Sterling Furniture Co., in this city, has enjoyed such a success that it has already found it expedient to enlarge the department. The space has been remodeled and beautifully decorated and in connection there is a miniature bungalow in which a Brunswick phonograph is displayed. Everett Saxe is manager of the department.

The new Victor record, "You Won't Be Sorry," a dance piece played by Whiteman's Orchestra, has made a fine start toward popularity on the Coast since it was released a few weeks ago. This selection is one of the song hits published by Sherman, Clay & Co.

The California Phonograph Co. has closed its Oakland store and will concentrate all business at the San Francisco establishment. Some of the Oakland stock was taken over by Harry N. Chesebrough, the well-known music dealer of Oakland. Manager Jessen was recalled to the San Francisco store of the California Phonograph Co.

### BUSINESS OPPORTUNITY IN ENGLAND

English Mercantile Firm Is in the Market for Talking Machine Motors and Records

WASHINGTON, D. C., July 7.—A mercantile firm in England, having a representative in the United States, desires to purchase talking machine motors and records, according to a request received by the Bureau of Foreign and Domestic Commerce here. Quotations should be f.o.b. American port. Terms, payment against documents. References are offered. Further information can be secured by communicating with the bureau or any of its district offices and referring to opportunity No. 2736.

### LAYTON BROS. VISIT GOTHAM

Recent visitors to Gotham included E. C. Bray, sales and advertising manager of Layton Bros., Ltd., of Montreal, Can., and Armitage and Gilbert Layton, who were in search of ideas relative to the talking machine and radio fields which they could apply to use in their territory in Canada.

Nelson V. Edgar, 162 S. Glassell street, Orange, Cal., is planning to open a music store in the near future.

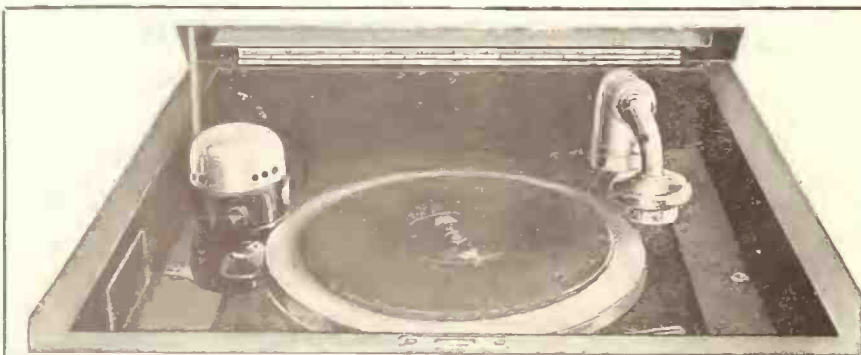

### THE SHELTON Electric Motor

The "Simplicity" electrifies Victor, Edison and Columbia phonographs by simply taking off winding handle and placing motor against turntable. Automatic switch in motor operated when the turntable is started or stopped. Operating on AC or DC current of 110 volts. Specify type of current when ordering.

SHELTON ELECTRIC CO., 16 East 42nd Street, New York



# HAPPENINGS IN THE DOMINION OF CANADA

## MERCHANTS IN TORONTO ADOPT AGGRESSIVE METHODS

Unusually Enticing Window Displays Aid Machine and Record Business—Vocalion Records by Canadian Artists Well Received—Changes and Trade Activities of the Month

TORONTO, ONT., July 7.—That a great musical movement is afoot in Canada was affirmed by Dr. A. S. Vogt, Dr. James L. Hughes and Duncan McKenzie at the close of a fascinating demonstration of educational talking machine records at the Toronto Conservatory of Music. This was the first of a series of six evenings. The hall was filled to capacity and the audience of teachers and friends listened with intense interest as it was shown how children in the junior grades could be introduced to the best music through the use of reproducing machines.

Your correspondent noticed in the window of one of the biggest music stores in Canada the other day a card bearing the titles of ten "His Master's Voice" records. These records appeared under the headline, "Album of the Immortals," and nearby was an album filled with each of the ten records: 87070, "For You Alone" (Caruso); 87243, "O Sole Mio" (Caruso); 64454, "Gavotte-Mignon" (Maud Powell); 18595, "Train Time at Pum'kin Center" (Cal Stewart), and "Uncle Josh and Nancy Put Up the Stove" (Cal Stewart); 64457, "Barcarolle—Tales of Hoffman" (Maud Powell); 64411, "Beautiful Isle of Somewhere" (Evan Williams); 64389, "Just Awearying for You" (Evan Williams); 87321, "A Dream" (Caruso); 18311, "Narcissus" and "Humoresque" (Felix Arndt); 18284, "Valse Blue" and "Marionette" (Felix Arndt)—a good idea.

A new link in the phonograph store chain of Welland, Ont., is Tuck's Music Store, which carries Starr phonographs and Starr-Gennett records.

P. P. Kruger, 212 Victor avenue, has been granted patent rights on a new design of phonograph tone arm and reproducer.

Minifies Music Store, Sarnia, has lately sold the Sarnia School Board three Columbia Grafonolas. The Canadian Radio Corp., Ltd., has been al-

lowed by Ottawa fourteen claims on an electrical device for producing musical notes. Said device is registered under number 217813.

Several of the music stores in and around Windsor, Ont., ran special displays to mark the "Better Furnished Homes Week" held there recently. The Malloney-Connolley Piano Co. issued a special invitation to the public to visit the store and familiarize themselves with its lines, including pianos and Vocalion and Edison phonographs. Grinnell Bros. had their show window artistically laid out to represent a completely furnished living-room. The Columbia Grafonola Store featured an electric Grafonola as a suitable companion for a nicely furnished home. H. R. Sill's Music Store, of Walkerville, also co-operated by a varied display of musical instruments and sheet music.

Marguerite D'Alvarez, the great Peruvian contralto and Vocalion artist, made a very agreeable impression upon her audience while in this city recently.

The Scythes-Vocalion Co., Ltd., of this city, is now offering for sale Vocalion records made by Albert Downing, well-known Canadian tenor, who has the honor of being the first Canadian to make records for this company.

Arrangements have been completed by this company with Miss Lorraine Wyman, a widely-known singer, to record French-Canadian folk songs for the Vocalion.

Employees and staff of Layton Bros., Ltd., Edison, Brunswick and Columbia dealers, were guests at the fourth annual picnic and outing given by Philip E. and Herbert A. Layton recently at Otterburn Park. Between seventy-five and eighty employees, with their wives, children, sweethearts and friends, enjoyed one of the most successful "get-together" meetings held by the firm.

Logan in his Danish Ode. "It turns out now that it's the medicine of the muscle, too—Walter Camp's Daily Dozen is a set of physical exercises set to music. And inspiring music. People who may have found exercise tedious mentally will find this method an enjoyable recreation. Good for reducing also.

"Five records in an album—vocal instructions and instrumental time—a chart of exercises—the lot for \$15."

Arthur Blouin, Sherbrooke, Que., is reorganizing and enlarging his record department. A practical young lady will shortly preside over this end of the business. Mr. Blouin reports the sale of new Columbia Grafonolas and Brunswick phonographs as quite satisfactory.

The local branch of the Musical Merchandise Sales Co., Toronto, Brunswick distributor, which is under the management of S. J. O'Donnell, has been moved from 719 Drummond Building to 364 St. Catherine street, East.

The leading music stores handling "talkers," as well as the exclusive talking machine shops, are closing at 1 o'clock on Saturday afternoons during the months of June, July and August.

The Berliner Gramophone Co., Ltd., has secured the selling rights in Canada for Walter Camp's Daily Dozen and it is putting out a large number of sets daily.

Brown's Talking Machine Shop will shortly install a radio department. It reports a goodly demand for "His Master's Voice" console models, which it claims are selling freely, a large number of users turning in their table models in exchange for the newer console types.

Miss Didier, in charge of the phonograph department of Dupuis Frères, has on more than one occasion made direct importations from Paris, France, of Pathé records, for which she has a large sale, particularly the complete grand operatic selections. She also handles the machine manufactured in Paris, France, of which she sells quite a number.

### "HONEST QUAKER" LINE IN CANADA

The G. L. Laing Co., talking machine accessory jobber, 41 Richmond street, Toronto, has completed arrangements to handle "Honest Quaker" mainsprings in Canada. These springs, manufactured by Everybody's Talking Machine Co., of Philadelphia, comprise styles adaptable to any kind of motor. In addition a complete line of motor parts manufactured by this concern will be handled by the G. L. Laing Co., which is planning a vigorous campaign.

### HEADS CANADIAN PLAZA OFFICE

TORONTO, CAN., July 7.—M. G. Beatty, well known in the talking machine jobbing trade here, has taken over the Canadian office of the Plaza Music Co., of New York City. Mr. Beatty's headquarters are located in this city and he carries a complete stock of talking machine accessories and repair parts for talking machine motors.

## "TALKER" AND RADIO CONCERTS FOR MONTREAL KIDDIES

Musical Concerts of Educational Nature to Be Held in Various Playgrounds—Record Artists Appear in Local Theatres—V. P. Bouvier Plans Trip—News of the Month

MONTREAL, CAN., July 8.—It was announced by Dr. Gadbois, director of playgrounds, that the first open-air radio concert for children will be held shortly, as soon as arrangements are completed for the instruments. The demonstration will be educational as well as entertaining, and will be held at Parc Lafontaine. Besides the radio show, a talking machine will also dispense music for the kiddies. If the experiment at Parc Lafontaine is successful the apparatus will be taken around to the various playgrounds.

J. Donat Langelier, Ltd., has installed a radio department in addition to its phonograph and piano business.

The Famous Chicago Novelty Orchestra appeared recently in person at the Princess Theatre, Sherbrooke, Que., and was billed as Columbia and Edison artists.

"Fronsi," Edison accordion artist, recently appeared here in vaudeville at the Imperial Theatre (Keith's) and demonstrated his talent as a master of his instrument.

Gingras Pianos & Gramophones, Ltd., this city, has made an assignment for the benefit of its creditors.

V. P. Bouvier, of Bouvier, Ltd., Edison and Columbia distributor, St. Catherine street, East, will shortly visit New York on a combined pleasure and business jaunt and while in the vicinity will take a trip to the Edison plant in Orange, N. J. This concern has opened a branch store at 1255 St. Lawrence boulevard, specializing in

foreign Columbia records. Henry Rheume is in charge.

C. W. Lindsay, Ltd., recently gave over its handsome show windows to a display of Stewart machines, appropriate suggestions directing attention to their popularity as a suitable companion for Summer camps and homes. A most effective showing of various Columbia Grafonola models was also staged.

The Venetian Gardens has the distinction of being the first cabaret in the Dominion of Canada to install individual radio telephones at each table for the entertainment of guests.

This is the way Goodwin's, Ltd., of this city, advertised "Walter Camp's Daily Dozen": "Music's the medicine of the mind," wrote John

## Talking Machine Springs and Repair Parts

NONE BETTER IN QUALITY NONE LOWER IN PRICE

THE RENÉ MANUFACTURING CO.  
MONTVALE, NEW JERSEY





I don't know why I should cry o-ver you, sigh o-ver you, e-ven be blue,

The Big Waltz Ballad Hit

# Why Should I Cry Over You

It's Another "I'm Sorry I Made You Cry"

HEAR IT NOW!

"You can't go wrong With any FEIST song"

## SALT LAKE CITY

*Dealers in This Territory Most Optimistic Regarding Trade Outlook—Interested in Radio—Many New Talker Agencies Opened*

SALT LAKE CITY, UTAH, July 1.—Some of the dealers in talking machines seem to be doing fine just now. The O'Loughlin Co., which will handle the Brunswick line exclusively hereafter, expects to do nearly twice as much business this month as it did in June of last year. "Ukulele" Hughes, formerly with the Glen Bros.-Roberts Piano Co., where he had charge of the small goods department, is with this firm now and he tells your correspondent that the company is putting on a "stunt" soon that will "start something." He would not say what it will be, but declared it will be worth watching.

George A. Bolduc, the popular manager of the talking machine department of the Glen Bros.-Roberts Piano Co., who went to the Coast with the Shrine Band, of which organization he is a member, is not home yet. He is making a tour of southern California and may go to Honolulu before returning to this city and—work.

Col. Jos. J. Daynes and family are making an extended tour of the Northwestern States.

The Western Radio Sales Corp. is the name of a new concern that has been formed here to sell radio supplies to the trade. It will make a drive on local dealers who could carry radio equipment along with their other goods. Some of the music dealers do not seem at all anxious to handle radio sets yet. They regard wireless as being in its experimental stage and a little hazardous from the merchant's standpoint.

R. F. Perry, manager of the phonograph sales division of the Brunswick-Balke-Collender Co., on West South Temple, has just returned from a trip through the Idaho territory and reports

business conditions there in the phonograph line as much improved. He said there was an increasing public demand for Brunswick products and several new accounts were opened. He

### VOCALION DISTRIBUTOR IN BOSTON

Arthur C. Erisman Appointed Wholesale Representative in New England for Vocalion Red Records, With Headquarters in That City

The Aeolian Co. has announced the appointment of Arthur C. Erisman, with headquarters at 174 Tremont street, Boston, as New England distributor for Vocalion records, the new arrangement going into effect on July 1. In order to give his entire attention to the Vocalion line Mr. Erisman disposed of his entire stock of records of other makes. The business will be conducted under the title of the Arthur C. Erisman Co.

Mr. Erisman is one of the best-known talking machine men in New England, having been manager of the Boston branch of the Columbia Co. for a number of years and then being in the wholesale business on his own account. The quarters on Tremont street, from which he will wholesale the Vocalion line, are particularly well situated in the heart of the business district.

C. D. McKinnon, Eastern manager of the Vocalion interests, is spending some weeks in Boston for the purpose of co-operating with Mr. Erisman in getting his new project under way.

Mr. Erisman will have associated with him in his new venture A. W. Chamberlain, H. M. Blakeborough and T. Norman Mason, all of

says there is a demand for the recording of exclusive Brunswick artists and feels that his company's machines and products are going to play an even greater part in the musical life of the Mountain States than ever. Mr. Perry said new accounts have been opened in Utah of late. One at Price, the seat of Carbon County, where they will be represented by the Burgener Music Co., and another at Park City and other places. The Brunswick people here are receiving increasing inquiries for the records of Mario Chamlee, the American artist.

them men of wide experience in the talking machine field.

The Aeolian Co. announces that it will make



Arthur C. Erisman

no further shipments of Vocalion records into the New England territory direct, and all record deliveries will be made through the A. C. Erisman Co., as New England distributors.

## RAYMOND RADIO CORPORATION

Manufacturers To The Radio Industries  
Apparatus Designed From The User's Standpoint

Crystal Detector Sets  
Vacuum Tube Sets, From One To Six Tubes  
Sets Of The Talking Machine Type Entirely Self Contained

V. T. Sockets  
Rheostats, Plain and Vernier  
Audio Frequency Transformers

Our non-regenerative 3-tube set was admittedly THE hit of the Chicago Radio Show

Executive Offices:

309 LAFAYETTE STREET  
NEW YORK CITY

Variable Condensers  
Crystal Detector Units  
Control Panel Units

Works:  
FARMINGDALE, L. I.





*Victor Wholesalers Exclusively*

**NEW YORK**  
TALKING MACHINE CO.  
521 West 57th Street

A.D. Geissler  
President

**CHICAGO**  
TALKING MACHINE CO.  
12 North Michigan Ave



# Mid-West Point of View

WESTERN DIVISION OF THE WORLD, CHICAGO, ILL., July 10, 1922.

The state of business throughout the Middle West in particular, and throughout the country in general, is eminently well set forth in the monthly Business Indicator issued by the National Bank of the Republic, of Chicago. In a series of well-executed graphs the bank displays the trend of general business during the present year as disclosed in the state of the Federal Reserve System, in the bank clearings, in the number of building permits issued in Chicago, in the price of pig iron, in the orders for pig iron, in the prices of grain and in the state of the bond market. The display is extremely interesting and most encouraging. Few of us perhaps realize that a good deal of the discontent which business men have been feeling over the condition of trade in general has been due to the insistence upon making their comparisons with the boom year 1919. The graphs which are a feature of the Chicago bank's Business Indicator show how absurd this practice is. The condition of all business during 1919 and until the break in the middle of 1920 was so exaggerated, so abnormal, that no useful comparison can be made between it and the conditions pertaining to any other year before or since. Now, as a matter of fact, 1922 so far shows actual improvement over the period 1913-1917 in a number of important items, such as bank clearings, while, on the other hand, the state of the building business at this moment shows, for the Middle West, a prosperity such as has not been known for years. Indeed, the number of building permits issued so far during the year 1922 in Chicago far exceeds any number previously registered. The Middle West is in for a boom in building, in home-making and, consequently, in retail buying, such as has not been known for years. Talking machine men, please take notice.

CONSIDERING the wonderful facilities which are now available in the way of sound-proof partitions, complete demonstration-booth equipment and similar utilities, it is surprising to observe how many talking machine merchants still seem to think that records can be sold in noisy, uncomfortable surroundings. It is still more surprising to find talking machine merchants neglecting the very obvious point of maintaining all demonstration machines in good condition, of seeing to changes of needles, that motors are oiled and silent, that tone arms and reproducers are functioning well, and so on. In some recent traveling around among the retail merchants in this vicinity we have observed with no little astonishment how often merchants otherwise seemingly keen and intelligent allow themselves to neglect the details of record demonstration service. Yet it is just here where the difference comes in between the high-grade merchant and the near-high-grade competitor. The foundation of successful record-selling is in comfortable, restful arrangements for the customer's benefit. To neglect this is virtually to invite customers to go elsewhere. Add to this fact the further fact that the best demonstration booth in the world is no good if it is not watched and served in the details of machine operation, and we have the whole secret of failure in record departments, as well as the whole secret of success. Have the booths really sound-proof! Keep them served! See that records are not played with old needles! Do not let the machines become noisy in operation. Remember that you are selling music and that music and noise do not go together.

THE representative of The Talking Machine World who attended the semi-annual furniture show which closes on July 15 at Grand Rapids, Mich., was much impressed with general conditions there. Pages 33-34 of the present issue of The Talking Machine World contain a complete story of the show at Grand Rapids, which lends point to our representative's impressions. Not only was the number of buyers in attendance very large, but the actual quantity of business transacted was a good deal larger than the most sanguine had anticipated. The talking machine exhibits were, for the most part, very

impressive. The Cheney Talking Machine Co. had a remarkable display in its beautiful warerooms on Monroe street. The Widdicomb Furniture Co. was also much in evidence, and so were Bush & Lane, the Consolidated Talking Machine Co. and the Aeolian Co. All these makers go in for the best, and the general effect of their exhibits was wonderfully fine, both as to fine workmanship and musical quality. The talking machine may be regarded, from one point of view, as a fine piece of furniture. When furniture buying is active it is safe to bet that talking machines are also selling. Well, furniture is showing activity again, and talking machines are selling. But one thing is sure: the talking machine that sells steadily and profitably is the talking machine of quality.

THE Chicago Furniture Show discloses activities similar to those of Grand Rapids in their encouraging features. It seems to be certain that retail dealers are now sold on the question of getting large stocks in hand for Fall trade. The controlling factor is, of course, the building situation. Despite a recession during the last two months, largely due to local conditions in one large Eastern center, the present movement has all the appearance of a real boom. Now, a boom in building means a boom in home furnishings. Furniture men are already boosting the home-building movement in their advertising, for they know that home building means furniture buying. But does not home building also mean talking machine buying? If not, why not? Let the talking machine men follow the excellent example set by their brethren and boost the home-building movement. The more it is talked about, the better the situation will be for everyone. The talking machine is a domestic article, a home maker as well as a home entertainer. No merchant is so admirably placed as the talking machine dealer in devoting a great deal of his time and advertising space to boosting home building. Every home that is built means a talking machine and a great many records. Anyhow, it behooves a live dealer to be a factor in the community and he can best occupy this position by putting himself in evidence as in favor of every movement that will help the town or city in which he is doing business.

THE Mid-West Victor Dealers' Association has been giving a luncheon to John Steel, the eminent Victor tenor. The guest of honor was voted a regular fellow. He sang to his hosts and showed them that his voice is all that it has been cracked up to be. During the same week, too, he was headliner at the Majestic, our leading vaudeville theatre. Naturally, the Victor dealers made a general tie-up with his appearance and sold many records through timely and judicious publicity. To bring together in personal contact the living artist and the men who sell the records he makes is always timely and always effective. The dealer needs to have this contact in order that he may the better visualize what it is he is really selling. The artist needs to come in contact with the men who sell what he produces, for then he can better understand their problems and realize that the salesmanship is just as important as the production. We should like to see much more of this intelligent tying-up. Mr. Steel is now on tour through the country in high-class vaudeville, and Victor dealers everywhere will take notice therefore of the opportunities presented to them to take advantage of his appearance.

WE hope it is not too hot to ask why there are not more trade associations springing up this year in the Middle West. As a matter of fact, the talking machine business is one of the very trades which most need strong local associations of dealers. It is hardly necessary to give reasons why local associations would be helpful. The fact remains that wherever they have been formed they have been a most potent means of making local dealers better acquainted—they remove silly prejudices and broaden out the minds of men and they bring men together for the uplift and development of the industry.

The  
Business  
Indicator

Tie Up  
With  
Home!

Obvious,  
Isn't  
It?

Contact  
With the  
Man

The  
Great Big  
Shows

Last  
Timely  
Topic



# From our CHICAGO HEADQUARTERS

REPUBLIC BLDG., 209 SOUTH STATE ST TELEPHONE WABASH 5242

EDWARD VAN HARLINGEN

WILLIAM BRAID WHITE

EUGENE F. CAREY

ARTHUR E. NEALY

A. SNYDER

CHICAGO, ILL., July 9.—Contrary to the belief that the hot Summer spells would cause a depression in business, it appears that just the reverse is taking place. This statement applies particularly to manufacturers. They have been doing an increased business for months. For a few weeks there was a short falling off, which seemed to indicate that a recession would prevail during the Summer months, but such is proving not to be the case. Business is beginning to pick up in a very substantial way, according to the manufacturers, and here is what they say is the reason:

A great many dealers, in fact, nearly all of them, are short on stock. It can also be said here that quite a number of manufacturers have not been piling up beyond their immediate needs. Therefore the surplus of talking machines in the country is not so great after all. It was thought a few month ago that the warehouses were loaded to the guards with goods of all kinds, mostly machines of inferior makes manufactured during the abnormal war days. There were great numbers of these products, it is true, but quite a bunch of them were sold. There were still greater numbers disposed of through the liquidation route, to concerns who had use for them in various ways. Many were bought to be dismantled so that the panels and other wooden parts could be used for other purposes. In this way thousands of these inferior instruments were taken off the market.

Many dealers who had machines of this kind on hand unloaded them at the beginning of the radio wave to radio fans who desired them for the installation of home radio sets. There was a time at the beginning of the year when radio

enthusiasts were being born every minute and they lost no time in manufacturing their own hook-ups. But it has been found that this whole manufacturing business was merely by way of a preliminary education, which has instilled radio enthusiasm into the fans to the utmost degree. The fans now know that they cannot get the same result out of cheaply constructed home instruments that they can out of one manufactured by a high-class concern. They are, therefore, contending that their home-made sets are all right for the time being, but sooner or later they will all fall in line for the purchase of "tailor-made" hook-ups. Now, all this accounts for great numbers of the inferior makes of talking machines, which once had the dealer scared into believing that when business picked up and people began buying there would be a flood of them on the market again, which would put a crimp in his happiness. Nearly every dealer is now convinced that "there ain't going to be no such happening."

As has been said before, the dealers have been quite short on stock, and this state of affairs was born of necessity. Now, however, there is every indication of a good Fall business, and the wise buyers are accordingly making hay while the sun shines, by looking over their stocks and reordering. This reordering in turn is naturally reflected in the factory of the manufacturer who likewise is getting busy.

Now, on what is the assertion based that business will be good in the Fall? The answer is found in the building movement, which is rapidly spreading to all parts of the country. Home building is being encouraged in all localities and

every effort is being made to relieve the housing shortage. No matter where one goes, in cities, towns or hamlets, or even along country roads—the sound of the hammer can be heard. One knows that very nearly every line of the industry is associated in some way or another with the building of a house. If house-building keeps on at its present rate a favorable reaction on other lines of industry must follow.

Furniture men throughout the country are taking cognizance of this activity, and are giving all the encouragement they possibly can to the movement. We suggest that it behooves the talking machine men to get in line with the furniture men and boost the home-building program. To-day there are literally thousands of talking machine prospects who for the moment are camping in someone's else backyard or doubling up with relations, in order to cut down the high cost of rents, which in a great measure has been caused by the housing situation. Just as soon as this situation is relieved and enough houses can be had to go around at reasonable rents those prospective buyers will loosen up their purse strings, take flats or houses and do a great deal of shopping. Figure it out any way you want to, and you will see that our future prosperity in all lines of business is hinged upon a comprehensive house-building movement. Therefore, we say again most emphatically, get behind and push, for the sweat of to-day brings the gold of to-morrow.

**The Power of Suggestive Advertising**

There is a great deal of power in suggestive advertising, as everyone knows. Then again  
(Continued on page 96)

**See Our Exhibit  
PAGEANT OF PROGRESS  
EXPOSITION  
CHICAGO, ILL.  
Booth 13, Section A**

**FEATURES**

**L**ARGE diaphragm and long stylus bar lengthens vibrations, producing a deeper and more natural quality of tone.

Perfectly balanced in accordance with carefully worked ratios and with regard to co-ordinate parts, this tone arm and reproducer permits a freedom and sweetness of tone heretofore thought impossible. Surface sounds almost entirely removed.

Throw-back design permits of easy access to needle socket. Saves records from unnecessary scratching.

**PLAYS  
ALL  
RECORDS**

**K**KNOWN the country over for its excellent quality of tone and natural, life-like reproduction of all musical tones, and its great volume. This tone arm on your machine spells success, because of its high standing in the Phonograph World.

Made only in 8½-inch length. Can be furnished with or without Mute Tone Modifier, with Mica or

**NOM-Y-KA**

diaphragm.

**THE JEWEL MUTE**

**C**ONTROLS volume just like the human throat. Built in the reproducer and functions in such a way that the length of vibrations is minutely regulated and the tone reproduced to a softness and clearness that are remarkable.

Operates by means of a thumbscrew and is instantly adjustable. Tone has free and unimpaird passage throughout tone arm and chamber—Not "Muffled" or "Choked" as with ordinary type of tone modifier.

Perfect regulation without in any way changing character of tone.

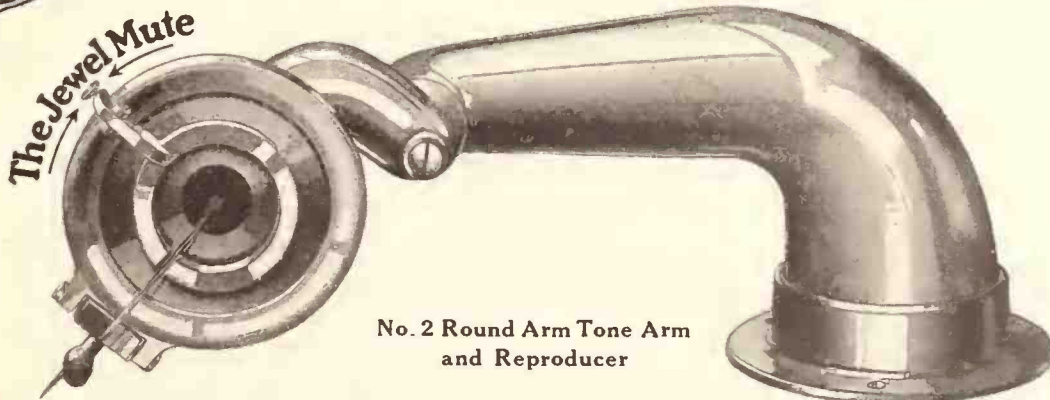

No. 2 Round Arm Tone Arm and Reproducer

**JEWEL PHONOPARTS COMPANY**

154 Whiting Street

Chicago, Ill.



## FROM OUR CHICAGO HEADQUARTERS—(Continued from page 95)

there are certain times when this suggestive advertising has great pulling power, especially if it is timely. A striking example of this may be seen this month in the show window of the Cable Company at Jackson boulevard and Wabash avenue. This window is well laid out and very appropriate for this season of the year. It is, therefore, attracting a great deal of attention and its suggestive power is asserting itself on the company's books. The display calls attention to Victor portables, but the hook-up to this portable is rather unique. The decorative scheme of the window suggests by the background that the scene is a shady nook in a wood. The foreground is laid out in imitation grass. Spread over the grass on one side is a lunch cloth whereon reposes a very tempting picnic lunch. Near the back edging of the lunch cloth is placed a Victor portable. Should one stand by the window for any length of time he will hear the remark, "Oh, boy! Don't that look good," and many of those who make this remark step inside and make im-

mediate arrangements to become the owner of a Victor portable.

**New Wireless Corporation**

L. Mandel, formerly president of the Mandel Mfg. Co., is now president of the Wireless Corp. of America, a Chicago concern which is manufacturing radio apparatus, supplies and parts. This company had a very attractive display of its goods at the recent radio show held in the Leiter Building. The Wireless Corp. has some interesting methods of assembling high frequency transformers, which they exhibited at the show and which attracted considerable attention.

**Schoessling Resigns from Wurlitzer Co.**

Hans Schoessling, who for several years has managed the wholesale Victor department of the Rudolph Wurlitzer Co., Chicago branch, has announced his resignation, to take effect soon. He has completed plans for the opening of a retail Victor shop in Chicago. He will call his new place of business The Jefferson Music Shop,

and will open it on or about October 1, in the vicinity of Milwaukee and Lawrence avenues, in the township of Jefferson, where Mr. Schoessling has lived for many years. Nearly everyone in this vicinity knows "Hans" and it is safe to assume that the new Victor shop will be a thriving place of business in short order. Of course, the retail Victor trade customers of the Wurlitzer Co. regret to see Hans leave, but they are all wishing him the best of luck in his new venture. His many years of experience in Victor circles have given him a keen insight into the methods of doing retail business.

**Service Shop Enlarges**

The Service Shop, owned by the F. C. Henderson Co., of Boston, is now located in its new and spacious headquarters at 26 East Randolph street. This shop was formerly located at 8 West Washington street, but business during the past year has grown to such an extent that it was found necessary to seek larger headquarters. The new Service Shop boasts of ten modern sound-proof record-hearing rooms and a number of spacious demonstration booths. Up-to-date record racks and counters decorate the front of the establishment. Forest Edwards, manager of this shop, which, by the way, is exclusively Victor, is enthusiastic over his new location and has received many compliments from the trade in Chicago because of the beauty of this place of business.

**The "Pilgrim's Progress"**

Will H. Wade, Potentate of Medinah temple of Chicago, returned to town with his caravan of nobles this week. They had gone to San Francisco to attend the annual Imperial Council of the Mystic Shrine. There is a story going around that when the Honorable "Bill" and his followers attended the Roundup at Cheyenne, Wyo., said Honorable "Bill" won a prize for exhibiting his prowess in sitting aboard a sea-going broncho. The "Honorable" refuses to divulge what said prize was. We thought we could find out from C. E. Johnson, Michigan representative for the Chicago Talking Machine Co., who was in the party, but he only held his sides and laughed.

**Views of Unit Construction Co. Manager**

W. B. Montgomery, district manager of the Chicago branch of the Unit Construction Co., has just returned from a trip through the Eastern half of the Central Western States. He reports that the trade in all sections visited by him are now convinced that the days of uncertainty and suspense are over and they are therefore preparing foundations for good substantial business. The trade now knows that appearance is a prominent factor in business life as it adds an air of stability. They are, therefore, remodeling and equipping the latest types of demonstration booths in order to lend this air of stability to their business. This has been proven true in other lines of commercialism, but the talking machine industry attained such proportions in so short a time that the trade really had no opportunity to take advantage of stabilization. It is doing so now, however.

**On Vacation**

S. A. Ribolla, manager of the Chicago branch of the General Phonograph Corp., and William Pilgrim, treasurer of that concern, are spending a month's vacation at Grand Beach, Mich. Both of these gentlemen were accompanied by their families. Mr. Pilgrim left Grand Beach for a run to Chicago during the latter part of the month. His visit here was short and he immediately returned to Grand Beach.

Another prominent member of the General Phonograph Corp. is A. Thallmayer, who is in charge of the foreign record division of this company. Mr. Thallmayer left his headquarters in New York some time ago for the purpose of calling on the trade throughout this section. While here he spent considerable time in Chicago and went over the retail field very carefully. His reports show that the Okeh foreign record business in Chicago is advancing rapidly.

**Templar Business Barometric**

A lot of the boys in the trade have been mak-

# The Best Motor Money Can Buy

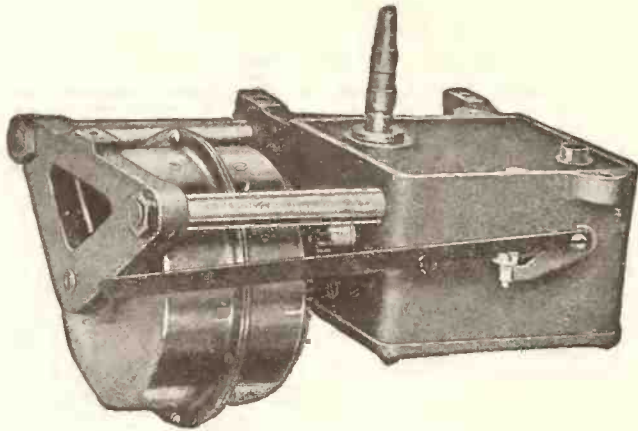

1. The wick lubricating system, an exclusive feature of our motor, keeps every part in the gear box running in a film of oil. Not a mere smear of grease to dry away and get gummy and hard with exposure to the air, causing noise and variable speed within a short space of time, but constant circulating lubrication.

For at least two years after our motors are installed the wick will circulate pure oil and governor and gears will be perfectly lubricated. Some of the high-priced motor cars have recently adopted wick lubrication—because it is right—continuous, automatic, certain.

2. The enclosed construction makes this lubricating system possible and also keeps dirt, bits of excelsior, lint and phonograph needles, etc., from getting into the works. This prevents those trouble cases that cost the dealer money and cause his customers annoyance.

3. The design of our motor lends itself to accurate alignment of bearing and springs. When our box-like casting is clamped into the holding tools to be machined it does not distort with pressure as open castings do. The reason we have almost no spring breakage is that perfect alignment does away with the side strain which causes crystallization and breakage of springs.

## REAL PRICES

1. We have a modern, complete, specially designed equipment solely devoted to the production of this motor.

2. Our plant is spacious, light, modern in every feature and our organization is seasoned and imbued with spirit of quality.

We have the necessary volume of output and can produce efficiently. Because of these facts we are furnishing a motor of positively unequalled merit, at unmatched prices.

Let Us Furnish You Samples

**United Manufacturing and Distributing Company**

536 Lake Shore Drive

CHICAGO



FROM OUR CHICAGO HEADQUARTERS—(Continued from page 96)

ing inquiry recently as to the condition of the manufacturing end of the business. Reports from houses dealing in accessories indicate that the manufacturers are going along very nicely at this particular time. The business of the Templar Mfg. Co. is going on at a very pleasing pace. This concern reports that it had anticipated a general falling off in business during June, but that, on the contrary, the demand for Templar stops was quite heavy during this month and many new inquiries were received.

**New Cheney Models**

At the Chicago office of the Cheney Talking Machine Co. this week the announcement was made that the new Cheney art models were now ready for distribution. Model No. 117, known as the Abbotsford, was announced to the trade on July 1. This new model follows the general lines of the present Queen Anne model No. 107, but is larger and of more ornate design. It comes in rich mahogany finish only, which is in general keeping with the type of ornamentation and treatment which characterizes that famous period. The new Cheney Abbotsford will retail at \$300.

**Opening New Store**

The North Shore Talking Machine Co., of 603 Davis street, Evanston, is opening a branch store in Winnetka, a suburb on the North Side of Chicago. Great activity is also seen around the Evanston branch by reason of the remodeling process which went into operation recently. The entire store is being redecorated and handsomely fitted up with the latest type of hearing rooms and demonstration booths. This is an exclusive Victor shop whose owners are aiming to have the most beautiful retail talking machine shop in that section of Evanston.

**Brunswick News Brieflets**

A. J. Kendrick, sales manager of the talking machine division of the Brunswick-Balke-Collender Co., has just returned from the East, where he attended the Music Industries Chamber of Commerce convention in New York. Imme-

diately thereafter he began a two weeks' vacation, during which time he motored throughout the New England States.

Gus Haenschen, of the Brunswick Co.'s recording laboratory in New York, is spending a few days in Chicago. Mr. Haenschen also made several other stops in the Central West before returning to New York.

B. E. Bensinger, president of the Brunswick-Balke-Collender Co., sailed for Europe a week or so ago for a combined business and pleasure trip. He was accompanied on the voyage by his family and the party will visit many points of interest in European countries, returning to the United States about September 1.

E. S. Bristol, proprietor of the Brunswick Shop at Rockford, Ill., was a visitor to the Chicago trade a few days ago. Mr. Bristol opines, and his opinion is in accord with that of other dealers at Rockford, that the Fall is going to see some mighty good business stirring around in Rockford territory. All lines of industry in that section, he believes, are getting into full swing, slowly but very steadily, and the building program is going on at a very rapid rate.

**Lyon & Healy Open Radio Shop**

Lyon & Healy are preparing for the formal opening of their new retail radio shop, which will occur about the time this issue of The World goes to press. The new shop is located on the Jackson boulevard side of their building, which was formerly occupied by an art store. The management of this new department will be looked after by Charles P. Hindringer. The interior decorations, fixtures, counters, etc., will all be of walnut. The layout of the store will be along the following lines: Accessories and parts will be handled on the main floor. Demonstration booths and complete receiving sets will be handled on the mezzanine floor. The repair parts and such will be handled in the basement.

Arrangements have been made for the use of the Lyon & Healy recital hall for three nights a week for the purpose of giving evening radio

concerts. Mr. Hindringer states that the line of radio goods carried by Lyon & Healy for both wholesale and retail purposes is complete in every detail and large stocks of goods are now on hand for the trade.

**More About Suggestive Advertising**

In another column is told a story on suggestive advertising by means of window displays. Still another example of the same idea has been worked out by Lyon & Healy, who, during the last week of June, devoted their great corner window to a wonderful display of Victor portable machines. The window here, unlike the other, suggests not the picnic, but the camp. The scenic layout depicts a camping scene on the border of a small stream. The background of the picture is heavily wooded and to one side of the window is seen a pretty little waterfall in actual operation, which supplies the stream which runs around the base of the window. The posed model is of a camper dressed in the conventional garb of a fisherman. The model is seated on the grass with his back leaning against a tree and immediately in front of him is a portable Victrola in operation. Scattered around in the foreground are the other accessories that are so essential to the life of a fisherman.

**Wins First Prize**

In last month's issue of The Talking Machine World there appeared an item telling of the Brunswick Co.'s Question and Answer Contest. The questions were set forth in connection with the story and details of how the contest was being run were also given. Since that time prizes have been awarded to the contestants who turned in the best answers to the list of questions. The first prize has gone to Miss Helen Moreau, who is connected with the sales department of the Lang & Hess Music Shop, Escanaba, Mich.

**Repeating Devices Attract Attention**

Some time ago we told in these columns the story of Piano Row and how it was making use of the Geer record repeater to attract attention.

(Continued on page 98)



"Built by tone specialists"

**IN ITS SEVENTH YEAR OF STEADY SUCCESS**

**4 Cabinet Styles:**

Mahogany, Walnut and Oak Finishes.

**Patented Tone-Deflecting System:**

Unsurpassed Workmanship.

**Vertical Record Filing:**

Mechanical and Acoustic Equipment Beyond Criticism.

Write for our *Revised Wholesale Prices*

**Magnola Talking Machine Company**

OTTO SCHULZ, President

711 Milwaukee Avenue

Chicago



Magnola Style Louis XVI



## FROM OUR CHICAGO HEADQUARTERS—(Continued from page 97)

The trade well knows that a moving object will attract greater attention than one which is not moving. A certain retailer on Chicago's Piano Row took advantage of this bit of psychology by using Geer repeaters as part of his show window dressings. These repeaters were mounted on moving turntables, some enclosed in regular machines and some without.

Since the working agreement was entered into between the Gold Seal Co. and the Walbert Mfg. Co. the dealers have added to the attractiveness of their repeater displays by showing both of these well-known instruments. The Gold Seal repeater is made of a material which looks like celluloid and can be had in many different colors. These bright-colored little devices, working all day long in a dozen Wabash avenue windows, have attracted a remarkable amount of attention from passers-by.

**Brunswick Picnic**

Employees of the Brunswick-Balke-Collender Co. will have their picnic this year on July 16 at Rainbow Springs, St. Charles, Ill. There will be plenty of fun as usual, with dancing, boating, fishing, races and games of all kinds. Trains will leave the Grand Central Station at 9 a. m., Chicago time, and return from St. Charles at 7:43.

The automobile route to the Springs will be over Roosevelt road, thence to bridge over the Fox River at Geneva, thence via the car tracks on the East River road for one and four-tenths miles to Fifth avenue, then a right turn on this road to St. Charles and through the town for a mile and three-tenths to the Springs.

It is expected that all officials and employees of the Brunswick Co. will be there.

**Professor Cheney's Educational Tour**

Plans for the second lap of the educational tour of Prof. Forrest Cheney, of the Cheney Talking Machine Co., have just been completed, and the professor is making ready for his departure over this route. The proposed itinerary covers Michigan, Indiana and Wisconsin. Professor Cheney will leave his headquarters at Grand Rapids and will call upon and visit every Cheney dealer in person. The trip is being made in the professor's Packard twin six, which is rapidly becoming the best-advertised car in the world. This car was made to order for Professor Cheney and is known as the "Blue Gull."

As has been said before, these trips are made for the purpose of bringing the professor in contact with Cheney dealers everywhere, in order that these dealers may have first-hand information and personal talks with him on selling

methods and other matters connected with good salesmanship.

By this personal contact selling methods can be intelligently talked over so that the dealer in turn may convey to the public the Cheney points of merit. Professor Cheney knows how to talk in an interesting and entertaining manner and in his recent trip through the Eastern section he made a great impression upon the Cheney dealers. One point that he brings out in his talk is not how cheap but how good can the Cheney Co. build its talking machines, as it is the constant aim of his company to insist that only the best material shall be used.

The professor also tells of his research and study in the realm of talking machines and also goes into detail in the history of the evolution of the Cheney talking machine and how he came to invent it. One big point in particular is that

**Prof. Cheney and His Famous Car**

every penny that can be consistently saved in doing business is utilized in some other way in material and so forth. An illustration of this, according to Professor Cheney, may be seen as one goes along the roads. One sees on every hand billboard after billboard where good money is wasted needlessly.

"Now, get me right," he continued. "I am not against billboard advertising, if it is done rightly, but the way it is being handled by a great many industrial concerns in this country is a shame. For example, when traveling around the country road one invariably sees from two to six billboards in some secluded spot all loaded down with the same ad. This is obviously wasted space and money." Instead of spending its money in this manner, the Cheney Co. believes in putting that money into its product and in this way giving the dealer and the public the benefit of every available penny in good merchandise.

On his recent Eastern trip Professor Cheney gave talks to dealers at such points as Cleveland, New York, Brooklyn, Newark and many intervening towns. The first trip was made in six

**Templar Autostop**  
It Stops as a Stop  
Should Stop  
For Proof of this,  
order a Sample

**TEMPLAR MFG. CO.**  
3225 Lexington Street  
CHICAGO, ILL.

weeks, during which time he drove "Blue Gull" over 3,000 miles.

**Give Factory Concert**

More than 500 people heard a wireless concert and entertainment recently at the Lyon & Healy factory. A radio instrument with an amplifying device was placed on the roof of the building, and another was fixed up inside. The concert, broadcasted from Station KYW, was heard by employes inside of the factories and by residents of the neighborhood, who congregated on the streets outside. Marguerite A. Healy gave a short talk and after 9 p. m. another program was given, with "Billy" Collins injecting a little of his characteristic humor with stories and songs. Miss Sylvia Chapleau gave some piano solos and her brother, Earl Chapleau, sang. Miss Mary Titus also sang, after which refreshments were served, followed by dancing. The entertainment was a big surprise and delight to the Lyon & Healy factory workers, who had never enjoyed this sort of thing before.

**Brunswick Goes Through Fire**

An interesting item in the Brunswick Dispatch—June-July issue—says that when a disastrous fire recently consumed the Rialto Theatre Building at Muskegon the Brunswick Music Shop, of that city, had a Brunswick talking machine in the theatre. Firemen patrolling the cooling mass of ruins came upon the charred and water-streaked case of a Brunswick with lid down and record on the turntable. It had stood through many hours of heat, smoke and water; yet when the firemen wound it up, the record played.

The Brunswick Music Shop will utilize the instrument for display purposes by placing it on the sidewalk in front of its store.

**Hold Annual Meeting**

At the recent annual meeting of the Midwest Victor Dealers' Association, which was held on June 28 in the Auditorium Hotel, the following officers were elected for the ensuing year: George W. McCauley, president; William C. Cotton, vice-president; C. T. Landherr, secretary, and Joseph Hassmer, treasurer. This Association is now in its second year and promises to do many big and important things before the next election of officers rolls around.

One proposal made at this meeting was that the Association hold two conventions each year in Chicago, that the conventions be of an educational nature and that they last for three days each, one to be held at the beginning of the year and the other in the middle of the year. It was suggested that the days be given over to educational programs and talks on salesmanship, etc., by officials of the Victor factory and that the evenings be given over to entertainments. Another suggestion was that the Association enlarge its field of activities by taking in Victor dealers whose places of business are located outside of the present boundaries of the Association, which are Chicago and Cook County.

The belief is that if these proposals are carried out greater activity will be manifest throughout the local Victor trade and increased sales will be a natural result. Owing to the lateness of

**VIS-MATIC**

The Most Wonderful Trade Stimulator and Profit Puller in the Talking Machine Field. Exasperated users groping to touch the record wished for, when wanted, has discouraged the use of machines.

"SELL" every tenth record buyer one VIS-MATIC and the records become at once accessible, accurately, assuredly and with but the finger tips of one hand. Resuscitates the playing of records and using of machines. Old records are discarded. New records and even machines purchased. **THE PULMOTOR OF THE TALKING MACHINE TRADE.** "SELL" the first VIS-MATIC and repeat orders are insured. Albums, unused, are discarded. A new lease of life is begun with this easy, convenient, accurate, accessible, instantly automatic, all-open, all-receptive, all-numbered, all-labeled, all-in-one "at-last" accomplishment. The "impossible" overcome. **MUCH MORE ACCURATELY AND EASILY ACCESSIBLE UPON A STOOL OR CHAIR OR OPENED UPON THE FLOOR, NEAR THE MACHINE, THAN ANY ALBUM SPREAD OPEN OVER THE REQUIRED LARGE AREA UPON A LARGE SPACE UPON A LARGE TABLE.**

VIS-MATIC IS THE AVAILABLE MEANS FOR MAKING SALES. A WONDER WORKER. 10" RECORDS ARE AS INSTANTLY FINDABLE IN THE 12" ALBUMS AS IN THE 10". A MARVELOUS FILING GAIN.

**UNYVERSAL UTLYTY UNYTS CO.**

6111 Winthrop Ave.

Chicago, U. S. A.

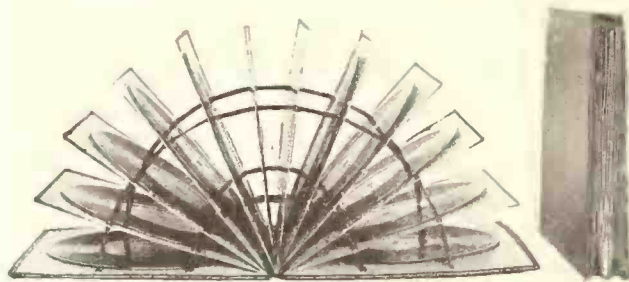



FROM OUR CHICAGO HEADQUARTERS—(Continued from page 98)

these proposals it was suggested that they be shelved until the next meeting of the Association, which will occur in a few weeks.

**Melody National Sales Co. in New Quarters**

The Melody National Sales Co. has just opened up a new sales office and display room in Suite 410 State and Lake Building. The new headquarters are much larger and more pretentious than those just vacated and offer greater opportunity for display. They are placed near the elevators and on either side of the entrance are two large show windows which are handsomely decorated for the purpose of displaying the latest models of Melody console type talking machines.

The interior decorations in this showroom suggest the music room of a fashionable home. Behind are two modern sound-proof demonstration booths, and behind these again is located the sales office. Two large windows in the sales office overlook the State street station of the elevated railroad, and these windows are therefore used for displays. There is a platform behind each window on which are Melody console models, which are thus easily seen from the station platforms.

C. C. Slack, of the Melody Sales Co., announces that in a short time he will offer a full line of radio-equipped console talking machines, which the factory is now building. Announcement of this new line will be made at a later date.

**Lyon & Healy New Service**

The Victor service department of Lyon & Healy is now offering a set of fifty-two ready-made advertisements to Victor dealers. One will be sent out each week for a period covering one year and with them will come letter-press proofs as well as matrices. All copy and drawings are the work of the Lyon & Healy advertising department, which boasts a large number of experienced, high-grade copy men and commercial artists. There are at present fifteen commercial artists connected with the advertising staff.

This weekly advertising matter will be sent out beginning on the first of July. It is offered to all Victor dealers at a nominal figure.

Another piece of service work that this institution is putting out is a weekly bulletin to Victor dealers in and about Chicago. This bulletin is for the information of dealers, telling them when Victor artists will appear at the big movie houses in their territory. This offers a splendid opportunity for these dealers to hook up with the appearance of the artists and call the attention of the public to the fact that their work can be heard on Victor records.

**Thieves Have Predilection for Sonoras**

F. S. Spofford, who conducts a retail music establishment in the Republic Building, reports the loss of two late model portable Sonoras. He says that some one must have slipped into the store while he was in his office and, unobserved, walked out with the two instruments. Quite a number of other retail places around Chicago have been complaining that some party, or parties, have been purloining parcels of their goods. It would be well for all retailers in and about Chicago to be on the lookout for this stealthy party or parties, in order to try to effect their arrest.

**Lakeside Supply Co. Dolling Up**

The Lakeside Supply Co. is effecting a transformation of sales and stockrooms at its new location at 339 S. Wabash avenue. Partitions reaching from the floor to the ceiling have been erected, for the purpose of dividing the salesroom from the stockroom and repair departments. There have also been erected several beautiful demonstration rooms of modern sound-proof construction, handsomely fitted up with comfortable furniture and silk hangings. There are two entrances to the Lakeside's new home, one being directly off of Mrs. Young's Cafeteria, and the other a private stairway, which leads directly into the north end of the warerooms. The demonstration rooms are located near the top landing of this private stairway.

This company is bringing out many new designs and talking machines of both the upright and console type, which are particularly well adapted for the installation of radio equipment. Quite a bit of attention was called to the Lakeside headquarters during the week of June 26 and July 1, at which time the National Radio Show held forth at the Leiter Building, within a stone's throw of the Lakeside location. Amateurs interested in building their own sets kept the Lakeside headquarters crowded and many of the company's talking machines adaptable for radio were disposed of to these amateurs.

**Prepares for Fall Business**

On July 10 the North Shore Talking Machine Co., Evanston, Ill., started its drive for Fall and holiday business. With the firm conviction that preparation is half the battle in commerce as it is in actual warfare, first attention was given to the efficient arrangement of the warerooms. The Unit Construction Co. is installing complete equipment. When completed the North Shore Co. will have an attractive and efficient layout

certain to prove an active factor in the merchandising of the Victor line which they handle.

**Honor John Steel**

The Midwest Victor Dealers' Association gave a luncheon on Friday, June 30, to John Steel, the prominent young Victor artist. The luncheon was the result of an outburst of enthusiasm on the part of Victor dealers in Chicago, and the culmination of a week's tie-up with Mr. Steel's appearance at the Majestic Theatre, which began June 26 and ended July 2. Thousands of people heard Mr. Steel during his appearance at the Majestic and Victor dealers all over Chicago tied up with his appearance by means of billboard, window and other methods of publicity. An exceptionally large number of enthusiastic theatre-goers kept the dealers of Chicago busy handing out Steel records and so successful was the week that the Association took it upon itself to hold a special meeting and give the luncheon in honor of Mr. Steel.

A large number of those in attendance had

(Continued on page 100)

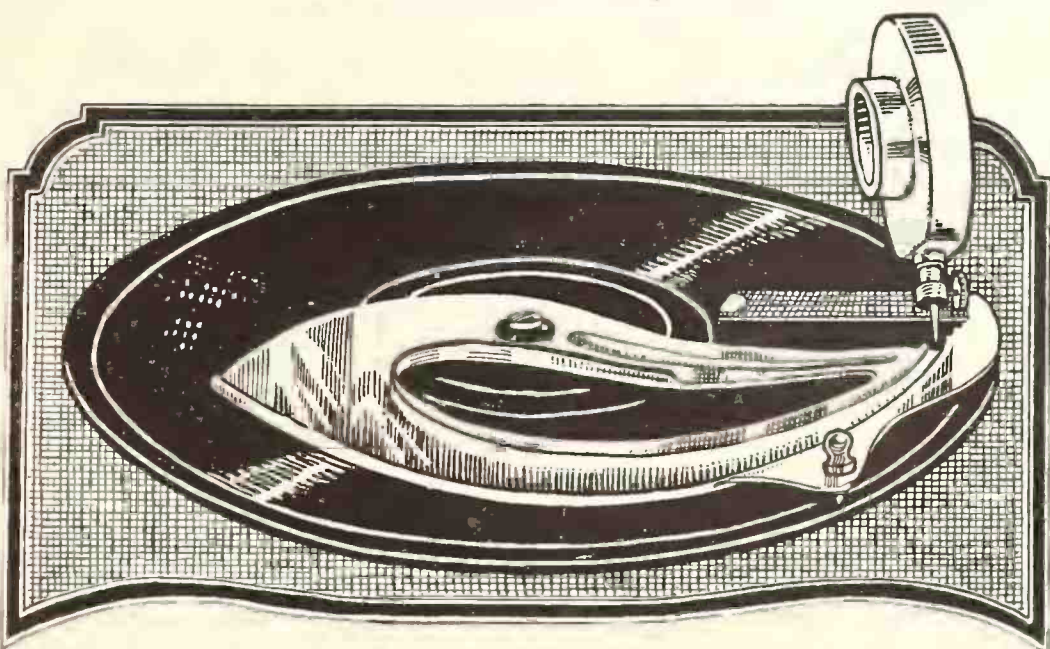

**How to Merchandise Repeaters**

EVERY phonograph retail store has two big merchandising problems. One is to sell phonographs; the other is to develop a profitable business in selling records, needles and other accessories.

It is in helping to interest prospects in buying phonographs and in influencing them to use their phonographs more, thereby stimulating sales of records and needles, that a record repeater proves its merchandising value.

For the benefit of our dealers, we have developed a special record without music that plays through in 18 seconds. This quick playing record is given free with orders of 12 or more repeaters and is unusually valuable in making window demonstrations.

Write your jobber or clip and mail the attached coupon—today.

**Important Notice**

The manufacturers of the Gold Seal Repeater have recognized the validity of the Geer Repeater patents and the litigation between them and the Walbert Mfg. Co. is settled.

The Walbert Mfg. Co. will manufacture and market the Geer Repeater as heretofore and will also act as sales representative for the Gold Seal Repeater in the territory west of the Alleghenies, including Canada west of Toronto.

The Gold Seal Co., 105 West Fortieth street, New York, will manufacture and market the Gold Seal Repeater under the Geer patents and will act as sales representative for the Geer Repeater in Eastern territory, including Toronto and Eastern Canada.

WALBERT MANUFACTURING COMPANY,  
925-941 Wrightwood Ave., Chicago, Ill.

Please send by return mail ..... Geer Repeaters and ..... Gold Seal Repeaters—price to be 40% off list—retail prices to be \$2.50 and \$1.00 respectively.

Check here if you want free window demonstrating record and sales helps.

Name .....  
Address .....  
Jobber .....

Terms C. O. D. to firms not rated.



## FROM OUR CHICAGO HEADQUARTERS—(Continued from page 99)

never before seen John Steel in person. Some of them thought he would be a great big barrel-chested tenor. They had been led to believe this by reason of hearing his powerful voice on Victor records, but what they really found in John Steel was a young and unpretentious man with a wonderful voice, who in appreciation for the little luncheon gave a few of his selections. Needless to say, each and every one of the guests were thrilled with the singing.

## New Sales Stimulator

W. McK. White, of the White Mfg. Co., Goshen, Ind., was in Chicago recently intro-



A Giant Size Tungs-tone

ducing a very novel trade stimulator to the Chicago trade. The article in question is a giant size Victor Tungs-tone stylus to be used for window and store display. It is an enlargement of the famous Victor Tungs-tone needle magnified 110 times. It is six feet long and seven inches in diameter. Although it is made

of steel, its actual weight is but ten pounds and its shipping weight is thirty pounds. It comes in two parts and telescopes in the center.

Mr. White claims that a number of dealers have found the giant needle especially effective for window display, and that it has attracted many customers into the dealers' store seeking information concerning the stylus. The giant stylus is manufactured by the White Co. at its Goshen plant and will soon be offered to the trade through jobbers. The illustration herewith shows the immensity of the article. The man shown in the picture is W. McK. White in person.

## Western Music Shop Opens Store

The Western Music Shop has opened a new store at 2451 West Forty-seventh street. Unico equipment consisting of audition rooms, record racks, service counters, sales stimulators and lighting units. The community which it serves offers an excellent opportunity for a phonograph shop and prompt and complete success is expected.

## Daily Papers Boost Wallace

The famous Wallace reducing records are being featured by daily newspapers throughout the country, which have been taking advantage of the opportunities offered and are putting on contests for stout ladies. The way they have been doing it is to form "lose a pound a day" clubs. The Tribune, of Terre Haute, Ind., was the first to bring out this method of advertising records. Here's the way they did it.

Down in Terre Haute is the big Root Dry Goods Co., which has a large Victor department. The store recently took on the Wallace reducing records and began pushing them with advertisements in the daily papers. The attention of the Tribune was called to the success of this new line of merchandise by the Root Co. and Anna Bowles Wiley, the feature writer of the Tribune, came out to cover the story. We are told that her report caused the editors to get busy and form a "weight-losing club" for the fat women of Terre Haute. The Tribune offered

a \$25 prize to the woman who should lose the largest amount of weight in a given time by means of the Wallace record, and the Root Co. offered an additional \$50 prize to the winner.

The offer of these prizes put considerable pep into the contest, so that by the time the opening day rolled around two hundred and fifty Terre Haute women were signed up. From this group three classes were formed, each of which was given an hour's lesson per day. A trained demonstrator from the Wallace Institute was placed in charge of the contest. Each of the 250 women bought a set of Wallace reducing exercises. Moreover, the Root store, as part of the program, sold a gymnasium outfit to each contestant. The affair made such a



Reducing Class of Root Dry Goods Co.

tremendous success that other papers throughout the country immediately began taking it up. The second paper which tied up with the idea was the Toledo News Bee, which connected with the Lion Dry Goods Co., of Toledo. The same success was scored in this case, and, in fact, is being scored wherever these contests are being put on. So numerous have been the requests to the Wallace Institute for trained demonstrators to carry on like contests that a new department has been established in the Wallace Institute for taking care of this business. The function of the new department is to take all inquiries and arrange them in circuits, as in the theatrical



RADIO — PHONOGRAPH

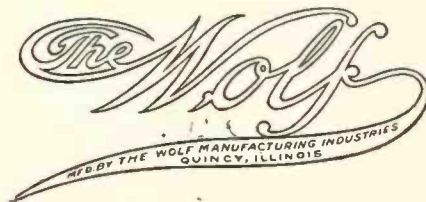

## A COMBINATION CABINET

Made so you can install

## Radio Panel or Panels

In One Side and Phonograph  
in the Other

This cabinet is Flexible to the wants of your trade—can even be sold by the dealer to the Radio Enthusiast who wishes to install his own Radio Set.

Made in Quantities and Carried in Stock by Us—so can give you Prompt Service on "Hurry-Up" Orders, Large or Small.

WRITE TODAY To THE WOLF MANUFACTURING INDUSTRIES

Sales Offices  
123 WEST MADISON STREET  
Chicago, Ill.

Factory and General Office  
110-126 3rd STREET  
Quincy, Ill.



FROM OUR CHICAGO HEADQUARTERS—(Continued from page 100)

field. In other words, bookings are being made in such a manner that when the Wallace demonstrator leaves the Chicago office she follows a route over a given territory and arrives in each place where the contests are to be held on date. Arrangements are also made for weekly bookings.

All the Wallace accounts that have put on contests of this nature have reported tremendous success in the new venture. They have all said that many talking machines, especially portables, have been sold to members of the classes. All these accounts say that their success is far greater than they had anticipated.

**C. G. Steger Gives Reasons for Optimism**

Under the caption, "Piano and Talking Machine Sales Grow in Volume," C. G. Steger, president of the Steger Piano Mfg. Co., in a recent issue of the Chicago Daily Journal, referred to general conditions, in part, as follows:

"The talking machine and piano business has been getting better since the first of the year and promises to be satisfactory this Fall. The demand indicates a preference for the more expensive instruments. Buyers are insisting upon receiving the utmost value for their money, but are willing to pay for the best, realizing that it is the most satisfactory in the long run. Grand pianos are selling better, comparatively, than up-rights. During the last year, instead of shutting down, Steger factories were kept going and orders were received in sufficient numbers to enable us to keep our organization busy.

"The music industry is on a strong financial basis. There has not been any overproduction of pianos or recklessness in offering selling terms, such as prevailed about seven or eight years ago. It is to be hoped that the banks will discourage any attempt to return to the old destructive 'wildcat' sales terms.

"Many manufacturers have taken losses as a result of the trying conditions of the last year. With favorable factors looming up, such as the encouraging outlook for the steel industry, extensive building construction work now under way,

betterment in the employment field and the growing buying power of the farmer, there is cause for optimism. This is best indicated by the

just secured Booth No. 13 in Section A at Chicago's Pageant of Progress, which will be held during the latter part of the month on Chicago's



Headquarters of C. G. Steger. "Well Equipped With Business Tools," Says System.

constantly increasing volume of orders. Crop conditions are fair and sentiment in the agricultural sections is improving considerably—which means added activity for the music industries."

Jewel Phonoparts Co. at Pageant  
A. B. Cornell, of the Jewel Phonoparts Co., has

big municipal pier. Three new tone arms, which will be marketed by this concern in the Fall, will be on exhibition.

The Jewel Co. has been working for months on various refinements and improvements, which are said to have never been offered before on any

(Continued on page 102)

*Sterling*

**Supersensitive  
Head-Set**

**For Commercial and Private Radio Service**

The Sterling 3000 Ohm Supersensitive Radio Head-Set embodies the very latest electrical and mechanical features of head-set design. Adjustable—with patent leather replaceable covering] on head band making it perfectly sanitary. Guaranteed against mechanical or electrical defects.

LIST PRICE  
**\$7.50**



**STERLING DEVICES CO.**

*Manufacturers of the celebrated line of Sterling  
Reproducers, Tone Arms and Attachments*

1819 Carroll Avenue

Chicago, Ill.



FROM OUR CHICAGO HEADQUARTERS—(Continued from page 101)

tone arm, and all of which include patented features. Jewel will also demonstrate its new Victor and Columbia attachments for playing all records.

Mr. Cornell reports that the factory is very much busier than could be expected at this time of the year, and that the outlook indicates a large increase in business for the balance of the year. He states that business this year to date is far in excess of the corresponding period last year and that unless some unforeseen calamities happen to the trade, the entire industry will come nearer to normal business this Fall and Winter than it has since the period of depression began.

**Return From Europe**

By the time the July issue of The Talking Machine World reaches the trade Mr. and Mrs. A. G. Kunde, of A. G. Kunde, Milwaukee, will have returned to their home from a three months' European trip. The couple is expected to reach New York on July 8 and after spending a few days in that city will return to Milwaukee.

**Blood Co. Gratified at Prospects**

The Blood Tone Arm Co. is much gratified at the success of its new arm, which is quite extensively used now among the manufacturers in this country. There seems to be a desire on the part of the manufacturer for better merchandise, and a willingness to take the advice of those who know how to construct the tone chamber so it will conform to the conditions of the arm used. The old method used to be to make the arm fit the machine. Now this matter seems to be adjusting itself, as some of the best factories are making experiments to find out just what is best suited to the arm they expect to use.

Another matter of great importance is the length of the arm and its ability to withstand excessive vibration. The only reason that eight and one-half inches has been recognized as a standard in length is because the first independent maker of arms used that length and manufacturers of machines became accustomed to it. But adequate tests will show that a reasonably

long arm gives a more satisfactory tone, and eliminates much of the foreign noises which accompany all records to some degree.

**Ted Snyder's Live Music Headquarters**

Music dealers all over the country would do well to take a lesson from the store recently opened in Chicago by Ted Snyder, which might

every day. The result is enormous sales of sheet music, records, etc. How do they do it? Simply by means of the untiring enthusiasm and energetic efforts of the men connected with the organization. Imagine the head of an internationally known concern, a man of business and affairs, in the basement of a flooded building,



Views of Ted Snyder's Song Shop: 1—The Lobby. 2—Sheet Music Counter. 3—Record and Roll Department. 4—Demonstration Booths

safely be called the liveliest music establishment in the mid-West. While the average music merchant pulls off a stunt once a year Ted Snyder's Song Shop pulls off one every week—ofttimes

wading knee-deep in muddy water to rescue a cat and five kittens in order to place that cat and her family in the show window of one of the busiest thoroughfares of the world, thereby

# The PORTOPHONE



Open

**The Biggest Value in the Talking Machine Industry Today**

A Portable Phonograph built into a leatherette Traveling Case. Plays all makes of disc records with perfect tone.

The PORTOPHONE is the pioneer in the portable phonograph field, and more than 40,000 have been sold. Equipped with the highest grade, powerful, double-spring motor, regulator and turntable brake.

An instrument that is pleasing to the eye and the ear—a favorite in any home. The tone of the PORTOPHONE is equal to any instrument selling at from 5 to 10 times its price, a fact that is made possible through quantity production and organized distribution.

The Big Season for instruments of this class is just starting—tourists, campers, autoists and people with money to buy will soon be looking for a portable phonograph—and the PORTOPHONE is the answer.

A comparison of the PORTOPHONE will quickly prove our contention that it is the biggest value in the talking machine industry today. Made complete from the motor to the cabinet in one factory and sold through the legitimate channels of trade at a good margin of profit to the dealer.

Write us for full particulars at once.

**The CONSOLIDATED  
Talking Machine  
Company  
229 West Washington St.  
CHICAGO**

Branch, 2957 Gratiot Ave., Detroit, Mich.



Closed



FROM OUR CHICAGO HEADQUARTERS—(Continued from page 102)



**MELODY CONSOLE**

Height 36½. Width 36. Depth 20½. Heineman No. 77 Motor, Improved Blood Tone Arm and Reproducer. Genuine Mahogany. List Price \$125.00. Dealers' Price, \$60.00.

**MELODY NATIONAL SALES CO.**

190 N. State Street, Chicago, Ill.

Manufacturer

**MELODY PORTABLE PHONOGRAPH**

featuring the song-hit "Little Thoughts"? This was the act performed by Henry Waterson on the opening day of the store a few weeks ago.

But we are getting ahead of our story. The fact is, we have got so much to tell about Ted Snyder's new Song Shop that we don't know where to begin, and we can assure dealers who read this article that if they will apply just a little bit of the enthusiasm cited in our story their sales will show a marked increase.

To start at the beginning, we must travel over to the LaSalle street station and meet Ted Snyder, Al Jolson and Jack Partington, moving picture magnate, who arrived in Chicago expressly for the opening. They were met by a tally-ho coach drawn by twelve horses and seating forty-five of Chicago's stage celebrities. From the station they went to the office of the Herald Examiner, played for the first time a special bonus song written by Ted Snyder, received the "freedom" of the city for twenty-four hours and proceeded to the new Song Shop, where the opening program was inaugurated. They were greeted at the window by the aforementioned cat and kittens, which had been placed in front of a sign reading "Five Darn Fools Got Married for Money, But I Got Married for Love," advertising "Little Thoughts." It was a highly successful affair from start to finish. Two hours after the opening Frank Clark, Chicago manager for Waterson, Berlin & Snyder, was able to leave for Michigan to enjoy a little fishing trip, confident that the store would pay its way and score a great success, in spite of the fact that not one of Henry Waterson's friends and advisers before the opening would concede even the chance of pulling through successfully, with so elaborate and expensive a retail establishment for merchandising sheet music exclusively.

Many features contribute to the store's success. It boasts a silver dollar floor, which brings curiosity seekers who afterward became purchasers. This silver floor idea was thought up by Ted Snyder as something similar to the waterfall staircase in the Crystal Palace of New York, where patrons of this establishment walk upstairs on glass steps, underneath which is constantly flowing a stream of water. This, however, is only one of the novel features of Ted Snyder's Song Shop. The window displays each week are famous in themselves. For instance, the second week of the opening was devoted to "Sapphire Sea" and was illustrated by a large goldfish aquarium, in which a blue electric bulb set off the brilliant hues of the goldfish. A base of sand and a tropical setting further enhanced the "Sapphire Sea" display. The third week, "Dancing Fool" was featured. The window was painted to appear as though a brick had been hurled at it; in fact, the brick itself lay in the window, just in front of the song, carrying on its

face in large letters "Song Hit Here." The boxing gloves of Benny Leonard, with which he won the championship, were shown as a further inducement for passers-by to pause and gape at this bellicose display. These three are just a sample of the winning windows appearing in Ted Snyder's Song Shop each week. Here is real, live, aggressive merchandising of a nature calculated to win sales. Can anyone wonder why the Song Shop is so successful?

Much credit must be given the men responsible for the store's success. Frank Clark is a figure in Chicago's music publishing and theatrical life. He counts as his friends the biggest men of the profession and his particular hobby is pulling off stunts that astonish Chicagoans and bring business to his store. S. J. Hein is in direct charge. He worked tirelessly to prepare for the opening and his middle name could well be changed to enthusiasm.

**Vitanola Co. Decreases Capital**

The Vitanola Talking Machine Co., of Cicero, Ill., has decreased its capital stock of \$500,000 and 50,000 shares of stock at no par value, to \$130,000 and 5,000 shares of stock at no par value.

**Some Columbia Brieflets**

Sam Aroks, Columbia merchant in Racine, Wis., visited the Chicago office of the Columbia Co. the other day in a most jubilant mood, because business has shown a most noticeable incline in the past two weeks in his city.

July 3 witnessed the opening of Fred Mann's new Rainbo Gardens, the home of Frank Westphal and his dance orchestra extraordinary. This

organization has lured thousands of Chicago's merrymakers to its doors and supplied them with those snappy dance tunes which have made it so popular here as well as on Columbia records.

Hyman Metzger is the new proprietor of the Wm. Shuchalter Music Shop, at 1559 North Halsted street. Although at present the greater part of the business is in popular records, the new owner anticipates building up an extensive German record trade.

I. S. Leon, southern Illinois representative of the Columbia Co., has just returned from his trip to the Coast, where he attended the Shrine convention. He stopped off and paid visits to several dealers and branches en route.

Cyrena Van Gordon, Columbia artist and popular Chicago opera star, has been engaged to appear in the open air concerts at the Chicago National League Baseball Park (Cubs' Park) this Summer. This will offer many music lovers an opportunity to hear this splendid artist.

Among the singers who are entertaining Ravinia's opera-goers are Leon Rothier, Morgan Kingston and Graham Marr, Columbia artists who have starred in various roles in past seasons. They are great favorites and should enjoy a most successful season.

F. L. Thompson, Clinton, Ia., a Columbia record fan, recently visited the Columbia office here. He owns a rare collection of over four hundred Columbia records, including all by Oscar Seagle and Rosa Ponselle. He is a close adviser of the Clinton dealer, W. C. Volckman, on all new records as they are released and his views are always worthy of consideration.

**THE NEW ORO-TONE CONCERT EDISON EQUIPMENT**

No. 2-E. C.

MAY WE SEND SAMPLE ON APPROVAL?

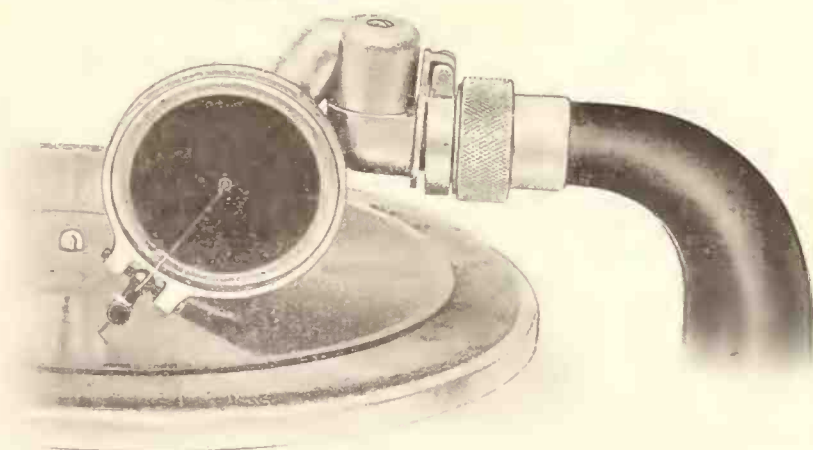

You and Your Customers will be Delighted with the Deep, Powerful Tone Quality Operated with the raising and lowering lever the same as the regular Edison reproducer. Retail price—Highest grade nickel plate..... \$7.25 Retail price—Highest grade gold plate..... 9.25 Usual Discount to Dealers

The above prices include this very essential and attractive needle cup case. Substantial and durable mahogany color leatherette. Fitted with gun metal finish needle cups as shown. Just what every Edison phonograph requires for needles and to hold either reproducer when the same is not in use. These cases will be supplied separately at 25c. each, less the usual discount.

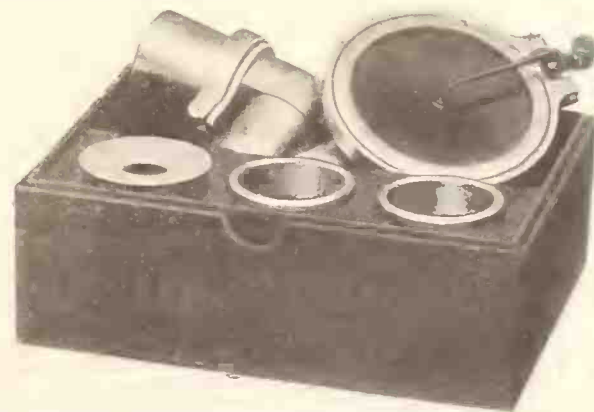

Order Your Sample To-day—It Will Be Sent on Approval Send for Folder Showing Wireless Equipment

**THE ORO-TONE CO.**

Manufacturers of Highest Grade Phonograph and Wireless Equipment

1000 to 1010 George Street, Chicago, Ills.



FROM OUR CHICAGO HEADQUARTERS—(Continued from page 103)

### BRUNSWICK RECORDS OF "CHICK" EVANS' GOLF SECRETS

Proceeds From Sale of Records Will Be Devoted to "Chick" Evans' National Caddy Championship Foundation—Splendid Plan of Widening the Popularity of Golf—On Sale This Month

CHICAGO, ILL., July 7.—The latest addition to the famous Brunswick line of records is none other than a set of five records which carry the message of "Chick" Evans' golf secrets. These five records divulge secrets which the famous golfer has never revealed to his closest friends and contain the real inside dope which has led him to so many championships.

These records will be sold without profit either to "Chick" Evans or the Brunswick Co., as the entire proceedings, except the actual cost of

problem by getting in touch with P. L. Deutsch, secretary of the Brunswick Co. These gentlemen in turn got together with W. A. Brophy, general manager of the Brunswick Co.'s recording laboratories. A plan was then worked out, and the five records, telling all about brassies, drivers, midirons, jiggers, stoppums, mashies, niblicks, etc., were recorded by Mr. Evans and prepared for the market by the Brunswick Co.

The money taken in by the sale of these records will go to the "Chick" Evans Foundation and will be held in trust by a Chicago bank for the purpose of paying all expenses of the National Caddy Championship, including the traveling expenses of the contestants. This will make possible to the caddy champions a college education when they shall have finished their grade and high school courses.

It will exert among the boys of America an influence positive in nature, help make them better men and citizens and direct their lives along right channels, not only in sport but otherwise.

The "Chick" Evans records will be placed on the market early in July and the caddies themselves will boost the good cause and direct inquiries to the dealers by soliciting and taking orders. The commissions which the caddies earn through taking orders for the records are, however, not for the purpose of paying their expenses to the National Caddy Championship Tournament, but will be their own, whether they attend the tournaments or not; if they do attend, all their expenses will be paid by the Western Golf Association.

A large number of sets of records have already been subscribed to by golfers of Chicago, many of whom had the opportunity to hear "Chick" Evans tell his secrets of par golf before they ordered. It was rather unusual (and yet it wasn't at that) that these Chicago players who heard the records ordered them immediately.



W. A. Brophy With "Chick" Evans

manufacture and distribution, will be devoted to the "Chick" Evans National Caddy Championship, under the auspices of the Western Golf Association.

The idea behind the "Chick" Evans Foundation is to give the caddies a chance to bring out everything in them, and to carry the game of golf more vitally into the lives of the boyhood of America.

How to take the element of professionalism out of the caddy tournaments and keep these boys in the amateur ranks was a puzzling problem. There were certain expenses which had to be met during the tournament and ways and means had to be devised so that the boys could meet these expenses. "Chick" Evans solved the

### NATIONAL RADIO SHOW HELD IN CHICAGO A SUCCESS

About Seventy-five Exhibitors Displayed Various and Latest Radio Developments at the Leiter Building—Attracted Quite a Crowd of Talking Machine as Well as Furniture Men

CHICAGO, ILL., July 8.—The National Radio Show, which held forth at the Leiter Building from June 26 to July 1, has just closed and from all reports the show met with greater success than had been anticipated. There were in all about seventy-five exhibitors and everything in radio ranging from the minutest part or accessory to complete receiving and sending outfits was shown. Some of these exhibits created quite a bit of interest and this was especially true of the Board of Education exhibit, which had Chicago school children demonstrating the simplicity of building home receiving outfits.

Among the exhibitors was the Tresco Radio Co., of 813-814 Putnam Building, Davenport, Ia. This concern manufactures a radio receiver which is licensed under the Armstrong patent. Their units are of the sectional universal type. This company has been manufacturing radio receivers for the past twenty years, and at one time operated under the Marconi patent.

The Winkler-Reichmann Co., Chicago, demonstrated the Thorophone, a handsomely made loud speaker, which has been received with much favor by the trade in general. This concern claims to be the oldest manufacturer of loud-

speaking telephones in America. The Thorophone concert horn is of heavy aluminum, bell construction with mahogany base.

The Duophone Mfg. Co., of Chicago, exhibited a complete receiving unit which is combined in a console type cabinet with a talking machine. These cabinets are finished in either mahogany or walnut and the amplifier of the talking machine is utilized as a loud speaker for the radio. The size of the cabinet is fifty-four inches long, twenty-four inches wide and thirty-one and a half inches high.

The National Radio Co., of New York, was represented by the Ayan-Jay Sales Co., of Chicago. The exhibit here consisted of headphones, radio dials and other radio equipment.

Quite a number of the exhibitors utilized the product of the Super Antenna Co., of Quincy, Ill., which concern manufactures a little device which connects a radio receiver with any electric light socket. Its purpose is to take advantage of the electric light wires that are strung from the alley poles and utilize them as antennæ. This instrument uses no electric power or current and is controlled by an "off and on" switch.

The Ekko Co., of Chicago, attracted much attention by its radio talking machine loud-speaking unit. This little device is made to fit all standard talking machines and all makes of radio headphones. It is devised to slip on the tone arm of the talking machine and then by means of a clamp the head receivers are hooked on. In this way the amplifying horn of the talking machine may be used as a loud speaker.

The Lyon & Healy exhibit, under the direction of Charles Hindringer, manager of Lyon & Healy's radio department, was the scene of considerable activity. Much interest was centered about the product of the Westinghouse Co., the Aeriola, Junior and Senior sets, distributed exclusively by the Radio Corp. of America. Aeriola sets are characterized by their extreme simplicity of operation, the absence of complicated adjustments and their light weight. Aeriotron tube detectors are used in the Senior sets, the Junior utilizing crystal detectors. Besides these sets Lyon & Healy exhibited a full line of radio equipment which they job, namely, Cunningham tubes, DeForest equipment, De Veau loud speakers, Remler supplies, Bowman radio receivers and Clapp-Eastham receiving sets.

The Bristol Co., of Waterbury, Conn., exhibited a compact and artistically designed loud speaker to which it has given the trade name Audiophone. The horn of this loud speaker is fifteen inches in diameter. It is adaptable for use on all types of two or three-stage power amplifiers. A little auxiliary unit this company manufactures is a special talking machine record transmitter and control box which can be utilized

Have 10,000 Tone Arms—Suitable for the Better Class of Phonographs  
Sample . . . . . \$2.50 Special Quantity Prices

**A HIGH GRADE  
DETECTOR TUBE**

**TRY ONE AND YOU'LL  
WANT MORE**

**List \$5.00**

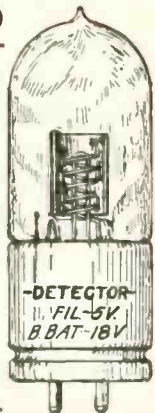

**NEW TYPE  
Balanced Condenser**

**TRY THESE FOR  
CLOSE ADJUSTMENT**

- 14 Plate . . . . . List \$3.00**
- 22 Plate . . . . . List 4.00**
- 42 Plate . . . . . List 5.00**

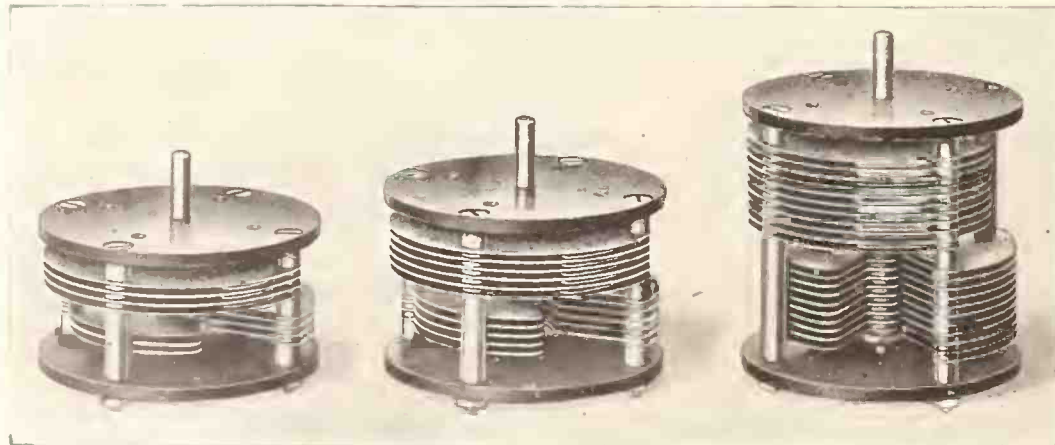

LAKESIDE SUPPLY COMPANY, 339 So. Wabash Avenue, Chicago, Illinois  
PHONE HARRISON 3840



FROM OUR CHICAGO HEADQUARTERS—(Continued from page 104)

for amplification of voice or talking machine records.

The Cruver Mfg. Co., of Chicago, exhibited their product, the Proudfoot super-sensitive detector and two-stage amplifier. This is a very small but compact amplifying unit which is fitted in a cabinet barely five inches deep.

The Electrical Research Laboratories, Chicago, showed a full line of Erla radio equipment, such as radio frequency transformers, variable grid leaks and condensers, as well as sockets, radio plugs and bezels.

Davistone clear speaker, guaranteed to give no vibration distortion, but absolute insurance of the clearest possible reproduction from radio sets, was exhibited by the Davistone Co., of Chicago.

Single circuit radio tuners with wave length ranges from 180 to 1,500 meters were shown by the Radio Sales & Service Corp., of Chicago. This outfit does away with loading coils or series condensers and is very easily operated in tuning. Their tuner employs a special variable mica condenser.

A crystal receiving set, known as the Dixie, was exhibited by the Darche Mfg. Co., of Chicago. Besides this little set, other products of this company, such as variable condensers, dials, sockets, etc., were shown.

States Radio Corp., Chicago, exhibited a receiving set which utilizes a loop antenna. The set is a very neat piece of workmanship, coming in a genuine-mahogany case with silver-marked dials and panels which are guaranteed not to turn color.

A large line of home receiving sets was shown by the Radio Units, Inc., of Chicago. This set is very compact and complete. Their model R. U.-1 is constructed with its own aerial.

The latest thing out in antennæ to be shown was the Shinn amplitone antenna cable, which comes packed in a neat box all ready for use. This antennæ cable is made of the regulation No. 14 gauge wire braided so as to offer a continuous one-inch-wide strip. This company also manufactures a carbon ground, which it claims assures absolute certainty in a ground connection and this in turn helps build up a greater capacity charge in the antennæ.

Another loud speaker to attract considerable attention is an artistic affair manufactured by the American Art Machine Co. This unit is made in two parts and is composed of "die cast" wood. The two parts are, namely, the radio horn and the radio resonance box and it carries the trade name of "Madera," and comes in three finishes, ivory, antique browns and Tiffany gold. The composition of Madera is of selected wood which has been broken down to its original fiber and molded under great pressure and heat into desired forms.

A very popular line that attracted considerable attention was the Estru Lattice Variometer and Variocoupler. These little units are extremely small and compact and offer great possibilities for inductance purposes. It was not the intention to design these units to produce an apparatus in miniature—the small size is a result of careful electrical design. This apparatus is manufactured by the Dalton, Wittier, True Co., Chicago.

The Weston Electrical Instrument Co., Newark, N. J., exhibited a full line of filament voltmeters, ammeters and thermo galvanometers.

Vacuum tube units for detection in two-stage amplification were shown by the Steinmetz Wireless Mfg. Co., of Pittsburgh, Pa.

The United Mfg. & Distributing Co., Chicago, manufacturer of the well-known United talking machine motors, exhibited a full line of variable condensers, which they manufacture. These condensers range from eleven to forty-three plates. They have devoted quite a bit of their well-equipped plant and seasoned organization to the production of numerous radio parts.

The Widdicomb Co., of Grand Rapids, exhibited a full line of its high-grade cabinets, especially designed for the combining of radio receiving units with the talking machine.

Another horn and loud speaker which attracted attention was that of the Beckley & Ralston Co., of Chicago.

The United Radio Laboratories had a fine exhibit, which was in charge of L. H. Morris, president, and at which E. W. Wesselmann, the sales manager, and Paul P. Ewing, in charge of the publicity, assisted.

Powel Crosley was another Cincinnati who was present with a comprehensive display.

The General Phonograph Corp. had an exhibit that was very interesting. This display was in charge of Homer Stephens, sales manager for the company. The exhibit consisted of the General Phonograph Co.'s product, such as head-phones and other high-grade accessories.

Other exhibitors who were present at the show with interesting demonstrations were the Aerex Radiophone Corp., American Art Machine Co., American Electric Co., Ampli-Radio Co., the Benson Co., L. S. Brach Mfg. Co., the Chicago Radio Co., Chicago Radio Dealers, Inc., Continental Radiophone Co., Drisco Mfg. Co., Electric Service Products Co., Ferry Radio Laboratories, S. R. Fralick & Co., Jefferson Electric Mfg. Co., Hercules Radio Corp., Hipwell Mfg. Co., Hughes Radio Electric Co., Indiana Electrical Specialty Co., J. E. Jenkins, Jewett Mfg. Co., Walter Lytton, Inc., M. & M. Mfg. Co., Maring Wire Co., R. C. Mills, Morscan Radio Co., W. G. Moyer, the Nash-Udell Co., Philadelphia Storage Battery Co., Post Electric Co., Radio Sales & Service Corp., Ray-di-co Organization, Raymond Radio Co., A. H. Redden, Schreuder-Lockwood, United Radio Laboratories, Universal Battery Co., Wireless Corp. of America.

NEW CHENEY DISTRIBUTORS

Important Connections Made in Los Angeles and Buffalo, N. Y.

CHICAGO, ILL., July 10.—E. A. Sanders, sales manager of the Cheney Talking Machine Co., announces the appointment of two new Cheney distributors in the West and East. The Munson Rayner Corp., of Los Angeles, Cal., has just signed up as distributor for the Cheney product in the States of California, Arizona and western Nevada. This important Coast organization will give the Cheney Co. strong representation in the West. Mr. Munson, formerly vice-president of the Melachrino Co., and Robert L. Rayner, son of the founder of Buck & Rayner, are the part-

BLOOD TONE ARM CO. Phonograph Equipment

326 River St. Chicago, Ill.

Unless you see this name on a tone arm it is NOT a Blood arm. Do not be misled by those who are trying to sell you a substitute for Genuine Blood Arms.

Look for our adv. in the August issue of The World. It cannot fail to interest you.

ners in this organization. The Munson-Rayner Corp. has been located in Los Angeles for four or five years, and its determination to take on the Cheney product means that highly desirable accounts in the Western territory will undoubtedly be established.

Another new distributor has been established with headquarters in Buffalo. This is John Adams Scanlan, Jr., who will have the State of New York from Albany to Buffalo. Mr. Scanlan formerly covered the Pittsburgh territory for the Brunswick-Balke-Collender Co. There his Brunswick sales per capita ranked third among all the Brunswick representatives in the country. Mr. Scanlan is a live wire in the talking machine line and has already put five men out on the territory in the interest of Cheney instruments.

NO LABOR TROUBLES AT STEGER'S

In an Interesting Article in Forbes' Magazine, Chas. E. Byrne Is Given Credit for Work in Maintaining Morale of Employees

"Why Steger Piano Co. Never Has Labor Trouble" is the subject of a most interesting article by George A. King in the June issue of Forbes' Magazine, in which the writer takes occasion to pay high tribute to Charles E. Byrne, secretary-treasurer, Steger & Sons Piano Mfg. Co., who joined the staff of that company ten years ago in a minor capacity. As a matter of fact, the article is something of a business biography of Mr. Byrne, whose experiences with the Steger Co. as an employe enabled him to map out a system whereby employes are provided with helpful entertainments during leisure hours and are encouraged to own their own homes and consider themselves partners in the business, and are treated in a way that has gone far to build up the morale of the organization to a notable degree.

KIMBALL Phonographs

Kimball prestige — long established—and a reliable guaranty are the foundation on which the dealer can safely build.



Style R Equipped with Albums 37 in. High 40½ in. Wide 23½ in. Deep

Variety of Designs in Console and Upright Models; Superior Construction; Attractive Appearance; Truth of Tone—these qualities command the attention of Dealer or Customer. Write for Agency Terms.

W. W. KIMBALL CO.

306 So. Wabash Ave. Kimball Bldg. CHICAGO







After the jazz has palled, when the popular song hit is passe, the old, old melodies will live on and on. There's a place waiting in every collection of records for such a genuine delight as Oscar Seagle's rich baritone voice in "Believe Me If All Those Endearing Young Charms" and "When You and I Were Young, Maggie." To demonstrate this record is to sell it. A-3619.

Columbia Graphophone Co.  
NEW YORK

## CANTON

*Trade Quickens—Windows Used to Good Purpose—Interested in County Fair—News of Month*

CANTON, O., July 5.—The past four weeks were among the most active of the entire year and the majority of the stores report that business was considerably in excess of the same period a year ago.

Several of Canton's leading music stores offered really attractive Independence Day window displays, which were the source of much comment in downtown retail circles. These displays not only brought out the timeliness of the holiday, but exploited the portable talking machine and the many occasions on which it might be featured.

The new Economy Furniture Store, which will open during this month, will carry a well-known make of talking machine, an official of the company announced this week. This store is located in Court avenue, N. W., and is the first retail store of any consequence to invade the avenue.

Canton music dealers, it is announced, will lend their co-operation to the Stark County Fair Board in making the annual Stark County Fair a success. The event opens Labor Day and it is understood that the majority of dealers will exhibit merchandise in the Merchants' Hall.

It is an even break between the Starr and Cheney machines at the Alford & Fryar Piano Co., according to C. M. Alford, head of the firm. "We are selling some talking machines, but not as many as should be sold," said Mr. Alford. There was only a fair volume of record business in June.

Edisons have been holding their own in the Canton district, according to information from Rhine's Edison Shop. Edison records seem to have moved more lively than other makes during the month, and Manager Rutledge reports an occasional machine sale.

At a recent meeting of the Retail Merchants' Division of the Canton Chamber of Commerce it was agreed that all music stores would close at 5 p. m. during July and August. This does not affect the usual Saturday 6 o'clock closing.

Sales at the talking machine department of the William R. Zollinger Co. department store nearly doubled those of June a year ago, according to Manager Pyle. There has been a falling off in machine sales since the first of July. The management of the department circularized the auto owners the past week, setting forth the features of the portable Victrola, and this store expects to do a big business on this particular machine during the month.

Medium-priced talking machines are the only ones that received the call during the past month, according to C. H. Shrake, head of the music department of the Klein-Heffelman-Zollars Co. Sales were very satisfactory, Mr. Shrake said, and now that this store has completed its new talking

machine department at the rear of the main floor on the mezzanine, it is able to display many more machines than it did when this department was located on the third floor.

Music dealers of Canton are delighted with the announcement that the Eight Famous Victor Artists will return to Canton next Winter as one of the numbers of the People's Music Course. The Victor Artists in past years have proved one of the biggest drawing cards of the entire series and their coming to Canton always has stimulated record sales.

### MORRISON & PUTMAN HOLD OPENING

Public Flocks to Establishment for Formal Re-opening Following Alterations

AMSTERDAM, N. Y., July 7.—It is estimated that at least 5,000 persons attended the opening of the Morrison & Putman music store on Market street, of this city, last week and listened to a delightful entertainment provided by Kolomoku's Hawaiians, who were stationed in the balcony of the establishment. The occasion marked the installation of four additional booths in the store, all being located in the Victrola department and giving the establishment a capacity of seven booths in all. The decorations of palms, ferns and flowers were most artistically arranged.

The opening was a tremendous success for the store, it bringing out many who were visiting the well-known business place for the first time.

### TO INTRODUCE SHELTON RADIO SET

W. Gentry Shelton, president of the Shelton Electric Co., which is well known throughout the trade through the production of the Shelton electric motor and the Shelton non-set automatic stop, is planning to produce a radio set to be known as the Shelton. The many years of experience that the Shelton Electric Co. has had in the electric field is a valuable asset to it in the production of this new radio receiving set. Much time has been spent in the perfecting of this instrument and it is expected that it will be ready for the market before long.

### NEW EDISON TURNTABLE PLAN

Thomas A. Edison, Inc., announced that the turntable plan of selling new Edisons had recently been revised along new lines which involve an increased rebate and which look toward increased selling results. Among other things a special series of turntable advertisements have been prepared for the use of Edison dealers in their local publicity work.

### "TALKER" MARKET IN NETHERLANDS

WASHINGTON, D. C., July 10.—An excellent market for talking machines, records and accessories is developing in the Netherlands, according to advices received by the Department of Commerce here from United States Consul General Anderson, stationed at Rotterdam.

### EDISON JOBBERS VISIT FACTORY

Center With Officials of Thomas A. Edison, Inc., Regarding Fall and Holiday Merchandising—Receive Message of Cheer

The latter part of June the executive committee of the Edison Disc Jobbers' Association visited the laboratories of Thomas A. Edison, Inc., at Orange, N. J., for the purpose of conferring with the Edison executives regarding merchandising plans for the forthcoming Fall and holiday seasons. The sessions lasted a full week and the various announcements made by the Edison officials to the jobbers' committee aroused the greatest kind of enthusiasm. In this connection A. H. Curry, vice-president in charge of the phonograph division, said to a representative of The World:

"The Edison Co. for some time past has been working on a number of important plans, which are due to be put into operation within the near future. The reception given the advance announcement of these plans by the visiting Edison jobbers proved highly gratifying to the Edison officials.

"The officials of the Edison Co. explained the revised and extended production program of the company, including various refinements of product and large-scale record production. Further details will be given later as better advantage of them can be taken by the Edison trade. The schedule of special facilities for 'hit' production and distribution, which was outlined, was received with particular enthusiasm by those present. The release of popular song and dance numbers by the Edison Co. will henceforth compete in a most vigorous manner in priority and quality with the rest of the industry. The Edison officials have aimed to secure advantages in special releases and are now enabled to offer their dealers something extraordinary in this line."

There was an enthusiastic vote of thanks from the visitors for the intelligent and skillful work of the Edison officials on the 1922-1923 plan of operations. A substantial profit and rapid turnover now seem assured by the Edison Co. to wholesale and retail dealers of Edison products.

The jobbers' committee which attended included Laurence H. Lucker, of Minneapolis, Minn., president of the Association; M. M. Blackman, of Kansas City, Mo., secretary; Albert A. Buehn, Pittsburgh; P. H. Oelman, Cincinnati, O., and George Schultz, of Omaha, Neb. L. N. Bloom, of Cleveland, the only absent committee member, was prevented from attending through illness. Thos. A. Edison, Charles Edison, Stephen Mambert and A. H. Curry were the principal representatives of the factory in the various conferences.

### INCORPORATION

The High Point Music Co., 200 North Main street, High Point, N. C., was recently incorporated in that State, with a capital stock of \$50,000.





Steinway & Sons, Cincinnati, Ohio



M. Steinert & Sons, Boston, Mass.

# Steinway - Victor - Brunswick

and

# The Unico System



Steinway & Sons, the famous Piano House, who represent the Brunswick Line thruout the Middle West, have installed Unico Equipment thruout their establishments.

M. Steinert & Sons, Steinway and Victor Distributors for New England, have installed The Unico System thruout their nineteen stores.

Unico Equipment has proved a Sales Increasing—Profit Producing factor with these well known companies —also with 2,500 dealers, both large and small, in all parts of the country.

*Ten Unico Service Branches offer you the same opportunities and advantages of the Unico System.*

**Quality** —the acknowledged standard of equipment excellence.

**Price** —within the reach of every dealer—irrespective of quality and patented features. Complete departments, including Audition Room, Record Racks and Counter from \$360.20 upward.

**Economy** —the Patented Principle of the Unico System Protects and insures your investment.

**Terms** —Deferred Payments—if you desire—enable you to Pay Out of Profits.

*Prepare NOW to Secure your Full Share of Fall and Holiday Business—  
Consult our nearest Branch TODAY.*

## Unit Construction Company

RAYBURN CLARK SMITH, *President*

NEW YORK, N. Y.  
299 Madison Ave.

58th Street and Grays Avenue, Philadelphia, Pa.

CHICAGO, ILL.  
30 N. Michigan Blvd.

ATLANTA, GA.  
49 Auburn Ave.

DALLAS, TEX.  
209 Dallas Bank Bldg.

NEW ORLEANS, LA.  
506 Marine Bank Bldg.

SALT LAKE CITY, UTAH  
150 Main St.

SAN FRANCISCO, CAL.  
942 Market St.

DENVER, COLO.  
1642 Arapahoe St.

H. A. MOORE & CO., LTD. (Sales Agents)  
Premier House, London (W.C.I.), England



# AKRON, O.

*Business Shows Decided Gain—  
Collections Improve—Dealers  
Very Active—News Gleanings*

AKRON, O., July 8.—After several weeks of unusual quiet in the talking machine trade business with the dealers in practically every instance shows a gain. Dealers are more cheerful with respect to the future and are well satisfied with the mid-Summer volume done to date, they say. Machines seem to be moving much better, especially with the better stores, where the standard makes are featured. Money is becoming easier and dealers say there is a decided improvement in collections, which is a sure indication of better business the coming Fall months.

#### Dales' Store Announces an Innovation

What is said to be an innovation in Akron retail music circles is the installing of a talking

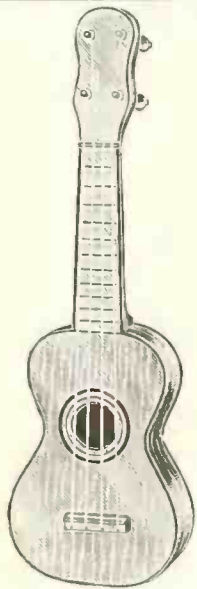

## Are You Getting Your Share of the Summer Profits?

You Can With a Small  
Assortment of

### MUSICAL MERCHANDISE

Such as

Ukuleles — Banjos  
Harmonicas — Violin Outfits  
Strings and Trimmings

It Means

No Additional Expense  
Quick Sales  
Liberal Profits  
Fine Window Displays  
Repeating Customers

We can supply you with the finest line of  
**MUSICAL MERCHANDISE**  
in the Trade at the Very Lowest Prices

Write for our 1922 Catalog  
Fully Illustrated  
(Just off the Press)



**BUEGELEISEN & JACOBSON**

5-7-9 Union Square  
NEW YORK

machine record shop, with a Main street entrance, by the George S. Dales Co., Victor and Cheney dealer. This shop is most modern in every respect and every patron of the store who enters the upstairs section must pass through it. Mr. Dales believes this will greatly stimulate record sales, as in the past the record department had been maintained on the second floor. It has been the experience of many dealers that record departments upstairs have proved a poor-paying proposition.

George Savage, for many years a traveling representative of the Eclipse Musical Co., Cleveland, has assumed charge of the talking machine department of the George S. Dales Co.

#### Miss Baer at Convention

Miss Elsie Baer, head of the talking machine department of the M. O'Neil Co., recently returned from the music trades conventions in New York and says the meeting was one of the most successful she has ever attended. Miss Baer reports record sales quiet for June, but said there is quite an improvement in machine sales and that Victor, Cheney and Brunswick machines were much in demand.

#### Adds Line of Talking Machines

The F. W. Van Scoyoc Piano Co., the newest Akron music concern, has added the Stradivara line of talking machines. To date it has installed no line of records in its new store.

#### Smith With Frederick Co.

Ernest V. Smith, for several months manager of the Akron, O., store of the A. B. Smith Piano Co., has been named district manager for Ohio by the W. F. Frederick Piano Co., of Pittsburgh, Pa., which maintains many branch stores in eastern Ohio.

#### Merchants Have New Plan

Akron retail merchants, including piano and talking machine stores, have joined with the merchants of other trades in the launching of a campaign which will protect them against out-of-town promotions. Before any solicitor or ticket seller can make a canvass of Akron retail stores he must first present his scheme in detail to a committee representing the Akron Retail Merchants' Association. This is the suggestion of Jack Moore, secretary of the Association, and approved by the majority of the merchants.

#### Windsor-Poling Co. to Foster Concerts

Earle Poling, of the Windsor-Poling Co., exclusive Victor dealer, has announced a series of six concerts to be offered next Winter by that firm, and which will bring to Akron many of the world's most famous artists, including Gallucurci, Olive Kline, Edward Johnson, Madame Schumann-Heink and others. There will be three individual concerts and six others will be offered as a concert series. This firm last Winter was responsible for sponsoring several previous concerts, but Mr. Poling says this year's series will surpass anything heretofore attempted in a musical way in the Rubber City.

The Windsor-Poling Co. is making a special effort to make a record of sales of the portable talking machine for camp entertainment. Results are proving more than satisfactory and the drive will be continued all Summer.

The music shop of J. Rudick will move to another location after August 1. The building housing the shop has been sold and the tenants have been ordered to find new quarters.

Ray A. Porter, who for several years has given much attention to the management of the talking machine department at the store of George S. Dales Co., has taken active charge of the jewelry department of the same firm.

#### Will Handle Talking Machines

The Baer Furniture Co., which will open its spacious new store on South Main street within the month, will maintain a large talking machine section, it is announced. Just what make machines and records will be featured was not made known at this time.

#### Records Move Better

An outstanding feature of the talking machine trade during the past month was the improvement in record sales. In all shops visited by the representative of The World records were reported moving better than in many weeks.

## COLLEEN MOORE BUYS A SWANSON

Popular Motion Picture Star Purchases Portable  
—Uses It at Studio and in Home

LOS ANGELES, CAL., July 5.—Miss Colleen Moore, motion picture star, who has been selected to play the leading part in "Broken Chains," the \$10,000 prize-winning scenario of the Chicago Daily News, was a recent visitor to the phonograph department of the Parmelee-Dohrmann Co., in this city. While there Miss Moore became keenly interested in the Swanson portable phonograph, which is featured in this department and purchased one for her private use. Miss Moore not only uses the Swanson at her



Colleen Moore and the Swanson

home, but also takes it to the Goldwyn Studios, where she plays it frequently during spare moments. The accompanying photograph showing Miss Moore and her Swanson was taken on one of the "lots" at the Goldwyn Studios.

## LAUNCHES CAMPAIGN FOR FALL

Collings & Co. Announce Arrangements to Take  
Care of Expected Requirements of Victor Dealers

Collings & Co., Victor distributors, of Newark, N. J., have just launched a Fall campaign through which Victor retailers in this company's territory are encouraged to complete plans and arrangements whereby they will be assured of Victrola stock for a six-month period.

The Collings & Co. house organ, The Record, announces the details of the Fall plans, under the caption, "Anticipation," in which is stated: "We wish to reiterate that our encouragement to buy now is placed upon an intelligent analysis of conditions as they exist. Moreover, rest assured that we are doing our part in protecting your interest by buying and stocking both machines and records to the limit of this company's ability."

## BRUNSWICK OFFICES MOVED

CLEVELAND, O., July 7.—The local headquarters of the Brunswicke-Balke-Collender Co. were recently moved from Huron Road to attractive and more desirable quarters at 624-634 St. Clair avenue, Northwest. The new headquarters are more spacious and offer better facilities for supplying the needs of the trade.

## MOTORS

Double spring, plays three 10-inch records without rewinding. Nickel plated, worm drive. Complete with all accessories. Sample \$3.25. Special prices in quantity lots. Motor suitable for portable machine.

## Pleasing Sound Phonograph Co.

Manufacturers—Jobbers  
204 East 113th St., New York City  
Jobbing Territory Open





*THE ORSENIGO PERIOD PHONOGRAPH*



WREST GOTHIC

A true exemplification of the art that has come down through the ages since its inception in the Third Century A. D.

Could the two arts—Architectural and Musical, be better combined than in this imposing cabinet?

TO DEALERS: We have endeavored to fill all orders in rotation and with despatch; but we respectfully request that all orders for fall delivery be placed as soon as possible to avoid disappointment and to insure early delivery.

*THE ORSENIGO COMPANY, Inc.*

*Showroom:*

112 West 42nd Street  
New York City, N. Y.

*Factory:*

Skillman Ave. and Rawson St.  
Long Island City, N. Y.





## Improve Your Department During the Summer Be Prepared for Fall and Holiday Business



The musical merchandise department store of M. Philips, Washington, D. C., completely equipped by Van Veen & Company

**VAN VEEN & COMPANY, Inc.** 413-417 E. 109th St., New York City

Phone 7758 Harlem

The efficiency of Van Veen equipment has been established through years of use by hundreds of successful dealers.

The prices of Van Veen equipment were never lower than at the present. Buying the best at the right price is true economy.

*Write for Catalog—the Equipment is Ready to Ship.*

Offices and Warerooms

# KANSAS CITY

*Large Wheat Crop Stimulates Business and Creates Optimism for Fall Trade—All Lines Enjoy Good Demand—Publicity Helps*

KANSAS CITY, Mo., July 6.—“Business?” “Fair.” “Prospects?” “Fine.” That is the substance of the conversations held to-day with talking machine jobbers in Kansas City. The one variation was in the case of A. A. Trostler, manager of the wholesale Victor department of the Schmelzer Co., and the newly elected president of the National Association of Talking Machine Jobbers. His response to the question, “Prospects?” was, “Oh, wonderful.”

The optimism for the Fall business is based on the increasingly large wheat crop which is being harvested, and the wonderful fruit crops which are ripening throughout the Kansas City territory, as well as the good prospects for most all other crops. Then there is the reassuring smile of the dealer as he comes into the Kansas City offices, and talks enthusiastically of the big business which he is going to do in the near future, and the fact that he backs his judgment with orders for the goods to sell.

An Edison dealer from western Kansas, in Kansas City this week, ordered the goods he wants for his sales during September. He knows there will be the business, but he was not sure that he could get the goods when he wanted them, so he ordered them in advance. Another Edison dealer visited the jobber this week and hauled home in his truck a full load of machines, reporting that he is now closing deals which he has had on the string since before the days of the depression began two years ago. Other dealers are reporting that conditions are assuming such a shape that now they are confidently going out to sell, whereas for the past two years they were convinced that it would not be much use to try to do so.

#### New Edison Consoles Please

W. W. Blackman, manager of the Edison branch here, has just returned from a conference of dealers at the factory. He is unusually enthusiastic over the conditions there, and the prospects of the fullest possible co-operation with the dealers in the way of increased facilities and

more marketable machines. One of the outstanding features of this service is the production of an Edison console model which will be offered at \$175. It is to be called the Baby Console, and will have all the high qualities of the other Edison machines. The Kansas City branch has just been able to get in its shipments of the Chipendale consoles, to sell at \$295, and its William and Mary consoles to sell at \$325, and these are finding ready takers. But with the coming of Fall trade, and with the Baby Consoles to offer, the management is expecting its biggest business.

#### New Record of Local Interest

A new Victor record, the release of which is looked forward to with more than ordinary interest by Kansas City folks, is that of one of the productions of the late lamented Billie Brown. This piece of Miss Brown's is entitled “Lonesome Mama,” and is one of a series of “Blues” which she wrote. The date of its release is announced as July 14.

#### Dealers Using More Publicity Material

Fred Jenkins, of the wholesale Victor department of the J. W. Jenkins' Sons Music Co., is finding an unusually ready response to his efforts to secure the co-operation of the Victor dealers throughout the territory in using the Victor publicity materials. There have been more of the dealers ordering the cuts to be used in newspapers and circular advertising than at any time in the past. His mail, and the field men, are bringing in reports of better use of the circular matter that is supplied, and a more intelligent appreciation of the value of the co-operation which the company offers the dealer in reaching the public. He considers this one of the most encouraging signs of better business for the future.

#### Sure Money in Standard Records

“The sure money is in the standard records—the ones that we can count on being bought for all the years to come. The so-called popular hits are a doubtful proposition. If the hit goes, and continues to be popular, there is big money in it. But if, on the other hand, its popularity is short-

lived we are apt to get stuck with a lot of records that we will never sell. We are finding good sales for records of the standard variety which we are listing with the regular monthly offerings of the factory. There is a growing demand for these records which we are thus bringing to the attention of the dealers,” said Mr. Jenkins.

#### Brunswick for the Shriners

The Kansas City branch of the Brunswick is in receipt of a photo of the machine, as it was being delivered from the truck, which was fur-

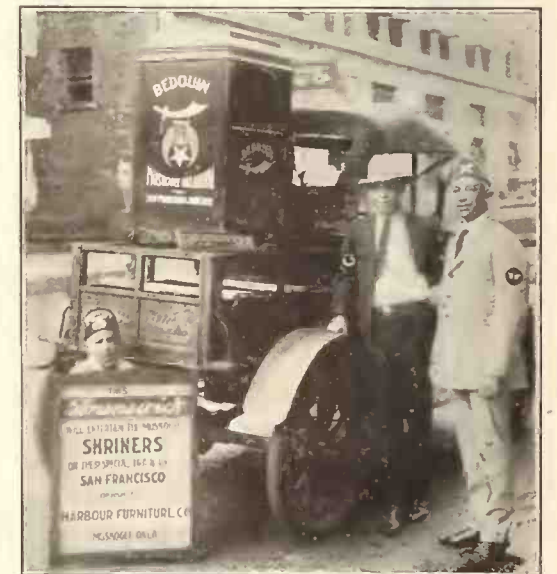

Brunswick for Muskogee, Okla., Shriners furnished by the Brunswick phonograph department of the Harbour Furniture Co. to the Muskogee, Okla., Shriners as they started on their trip to the big ceremonial at San Francisco recently. They were not satisfied to carry in their solid train of Pullmans their crack band, and their drum corps, both of which are justly renowned, but they secured the talking machine to give them the best of music as they sped along their way. The picture shows John Caldwell, one of the firm, in uniform, and his young son, who was a mascot for the bunch, and Harlan H. Winn, the manager of the phonograph department of the Harbour Furniture Co.

Ferguson Bros., of Muskogee, Okla., appreciate the value of the 1922 Columbia record catalog. They had a young man in uniform deliver one of these catalogs to the home of each Grafonola owner in Muskogee. No doubt the customer appreciates the value of the catalog more by having received it in this manner.

#### Brunswick Activities

Field Man Henry, of the Brunswick, is in from a trip through western Kansas, and is enthusiastic concerning the prospects for business in that part of the territory. He has been doing a good

## Cotton Flocks of Uniform Quality

FOR RECORD MANUFACTURERS

Guaranteed Free of Loading

Prices Consistent With Quality, Service and Market Conditions

Claremont Waste Mfg. Co.

Claremont, N. H.



business during June, and finds the dealers all ready to push the phonograph departments. The record sales have been good. Manager Briggs, of the Kansas City branch of the Brunswick Co., reports that the June business was about up to their business for May.

#### Working on Association Committees

President A. A. Trostler, of the National Association of Talking Machine Jobbers, is working away on his list of committees, and getting the matters pertaining to the Association well in hand. He is enthusiastic about the prospects for the coming year, and the things that are to be attempted for the good of the Association. He sees only the big opportunities that are before the jobbers in the future, and has full faith in the ability of the jobbers to take advantage of them. He expects to have some definite plans worked out and ready to announce in the near future.

The Ernest Dickerson Music Co., of Hutchinson, Kan., exclusive Columbia dealer, has prepared a folder about the size of the ordinary newspaper sheet featuring its line of Grafonolas and pianos, which have gone into many homes in Reno County and one-fourth of the homes in McPherson, Rice, Stafford and Kingman Counties. Mr. Dickerson is paving the way for a splendid music business this Fall after the crops are harvested.

The J. Ed. Black Music Co., of Springfield, Mo., Columbia dealer, believes in working the city of Springfield systematically for Grafonola business. It has a large map of the city of Springfield framed on a compo-board backing and each street divided into city blocks. On this map it has a tack showing the house location of every Grafonola owner in Springfield. This map is prominently displayed in its store and is a substantial influence on a prospective customer, due to the fact that it impresses on his mind the popularity of this line.

M. B. Kendis, of Sedalia, Mo., of the Kendis Jewelry Co., exclusive Columbia dealer, called on the Kansas City branch a few days ago after having returned from a few weeks' visit in Cal-

ifornia. Mr. Kendis said that he had a most wonderful trip, picked up many ideas and was very anxious to get back to his store and make some changes and improvements, and while he stated his trip cost him a few thousand dollars, he expects to make it up in Grafonola sales within the next few months.

#### HEALTH BUILDERS RECORDS STORY

Walter Camp's "Daily Dozen" Set to Music Being Sold at the Rate of \$1,000,000 a Year—Sold Profitably by Dealers Throughout the Country

The story of the Health Builders records, which consist of Walter Camp's "Daily Dozen" set to music, was told in an interesting article appearing in the July issue of Printers' Ink monthly. It points out that in April of last year, when Robert B. Wheelan, the president and founder of Health Builders, Inc., had published his first advertisement, several successful mail order advertising men, and also a number of prominent dealers, predicted that the "Daily Dozen" phonograph records could not be sold profitably through dealers. The fallacy of this prediction is to be found in the statement that business is coming in at the rate of \$1,000,000 a year and that a large part of this is contributed by 500 dealers throughout the country. The story relates how the mail order advertising of the company is also developing business for the talking machine retailer. It is Mr. Wheelan's belief that all extensive mail order advertising creates a demand that cannot be met by mail and that in many instances such a demand can profitably be supplied through dealers. He further states that at the present rate his organization probably will be shipping one-half of his output to dealers in the near future.

Mr. Wheelan's inception of the idea of setting Walter Camp's "Daily Dozen" to music in record form, together with descriptive and health charts, is described at length as well as his meeting with Nelson Doubleday, of Oyster Bay, and the forming of the partnership.

Mr. Wheelan stated in part, in the article in

Printers' Ink: "As soon as the new organization was working well I took up the matter of the dealer. I called on several New York dealers, but all of them balked at the price. We were selling the system at \$20, then, and that price, because of our small production, gave us a rather close profit."

He then told of the demonstration before The Talking Machine Men, Inc., although at that time with no appreciable results. Increased production soon brought the list price down to \$15, which proved attractive to the talking machine dealer. Mail order advertising created a demand by the buying public upon the dealer and trade journal advertising put the proposition direct to the dealer.

In closing, Mr. Wheelan stated: "Our experience shows plainly that a mail order proposition that has anything to do with an old-line business creates a demand through the old channel. Because our system used phonograph records as one of its features a lot of prospects would not break their buying habits but went to phonograph dealers to find out about it. The other class, represented by the ones who came to my office, we are trying to send to dealers. Thousands of them have written to us wanting to know where they can see and hear our Health Builders' system. We are now going after this class through mediums that we think will send them to the dealer."

#### UNICO INSTALLATION IN TUSCOLA

TUSCOLA, ILL., July 8.—H. S. Bassett, Victor retailer, of this city, recently installed a Unico demonstration room with double sound-proof insulated construction. With his added merchandising help it is expected that the sale of Red Seal records will increase materially through the opportunity afforded his customers to hear the records without disturbance.

The Hopkins Piano Co., of Chester, Pa., has added the Brunswick line of phonographs to its stock.

# Puritan Records

## WHAT CONSTITUTES A GOOD FIFTY-CENT RECORD

1. Good Material.
2. Careful Recording.
3. Experienced Artists.
4. Hits while they are "hits."
5. The backing by a well-organized company which allows entire safety in building up business for the future.

*The Puritan Records have all these qualities and offer you an excellent 50-cent Record Proposition.*

*If you are located in territory East of the Ohio and North of the Potomac it will pay you to write today for full details.*

**The BRIDGEPORT DIE & MACHINE Co.**  
170 ELM ST. BRIDGEPORT, CONN.



# C I N C I N N A T I

*Trade Is Normal—Retail Stocks Continue Low—Victor With Widener—Helping to Sell Records—Radio Makes Slow Progress*

CINCINNATI, O., July 8.—The even tenor of trade in the talking machine business in this city continued during the past few weeks. Neither extraordinary increase nor extraordinary slump was noted, though there are dealers who by unusual effort report slight increases in trade most noticeable during the past week. Practically all dealers are carrying only such stock as is absolutely needed, since it is now very easy to obtain stock quickly, and dealers are taking no chances of losing money on large invoices. For the most part the jobber is kindly allowed to carry the risk, while the retailer retrenches as far as possible.

#### The Dealers and Radio

Little enough practical activity is manifested in the exploitation of radio apparatus. With the exception of the Chubb-Steinberg Music Shop, the Victrola department of the John Shillito Co. and a small Norwood branch of the Otto Grau Piano Co., which only leases space to a separate dealer in radio equipment, no stores are making any effort to combine radio with talking machines. This is not so much due to the possible conflict between the two lines as to the extreme difficulty of even the slightest expansion. The stores which handle radio equipment, however, are doing very well with it. Various manufacturing plants also are making, or planning to make, radio apparatus. The Precision Instrument Co. is perhaps the most active and successful in this field. The Herschede Hall Clock Co. now is equipping an addition to its factory to take care of the manufacture, on a broad basis, of radio stock.

#### Widener's Secures Victor Agency

A new Victor account opened is that of the local branch of Widener's Grafonola Shops. Heretofore this store has carried the Granby and Columbia lines, but for some time has desired to add Victor goods to its stock. Owing to the policy of the Ohio Talking Machine Co., jobber in Victrolas and Victor records, not to overcrowd its field and thereby handicap its dealers, Widener's was unable to obtain an account. This is one of the chief reasons for the purchase by Widener's Shop of the store of the Werner Industries, which contained a Victor stock, the

Victor account of this store passing into the hands of the purchaser.

Morris Fantel, manager of Widener's, reports a fine business for June. Mr. Fantel said: "Our business for June was even better than that for May, which represented a 50 per cent increase over any month previous in 1922. Our trade has been uniformly better this year than last, in a comparison of months. There will, of course, be something of a slump during the very hot weather to come, but by Autumn it seems to me that business in machines and records should be fine."

#### Fine Business in June

Chas. H. North, secretary of the Ohio Talking Machine Co., reported a fair business for the month of June. Mr. North said: "Dealers are not buying many machines or records for stock. They are buying as they need supplies. Retailers are letting the jobbers carry the bulk of the goods and run the bulk of the risk of possible fluctuation in price. Time was, not so long ago, when retailers were unable to obtain enough machines and records to satisfy demands upon their stock. Now they are unable to find enough buyers to satisfy demands upon their income."

#### E. M. Abbott Piano Co. May Continue

It has not yet been decided what disposition will be made of the stock, both pianos and talking machines, of the E. M. Abbott Piano Co., which two weeks ago sued for and obtained a receivership. It is possible either that the company, upon disposal of its Seventh street branch, which seems to have caused the trouble, shall be allowed to continue in business in an effort to work its way out, or that stock will be disposed of to satisfy, in part, demands of creditors. Until the receiver completes a survey of the company's condition no decision will be made.

#### Unique Record Sales Stunt

H. L. Druly, of the Baldwin Piano Co., Muncie, Ind., has rigged up a unique arrangement to sell records to persons who come in to pay bills and instalments. He has attached a small record fixture at the side of the cashier's window. This fixture is so placed that the wings containing the records fall directly across the window, and it

is necessary for the customer to move them to one side to transact business with the cashier. This is salesmanship after the fashion of "Giving it to 'em and let 'em handle it." This method, said Mr. Druly, paid for itself in record sales the first afternoon that it was installed.

#### C. Link Back From Shriner Convention

Clifford Link, of Link's Music Shop, dealer in Columbia goods, accompanied Cincinnati delegates of the Mystic Shrine to the Shrine convention at San Francisco. He returned to Cincinnati by way of Seattle, Vancouver, Banff, St. Paul, arriving home near the end of June.

#### Grafonola for Palestine

Mrs. S. J. Goldstine purchased a Grafonola from Silverstein Bros., Terre Haute, Ind., and ordered it shipped to her husband in Palestine. Mr. Goldstine is opening a chain of retail furniture stores in Palestine and plans to handle Columbia Grafonolas and records.

#### Columbia Branch Picnic

The annual picnic of the local branch of the Columbia Graphophone Co. was held at Humboldt Park, near Cincinnati, June 16, on which day the usual jollity was in order. There was a big crowd and a good time.

#### Messages of Good Business

The business of the Aeolian Co., dealer in the Aeolian-Vocalion, has been satisfactory during the month of June, according to Manager Devine. E. I. Pauling, of the Starr Piano Co., also reports a very fair business in Starr machines and Gennett records.

Miss Yates, manager of the Victrola department of the H. & S. Pogue Co., also reports a good business for the past month.

## DEATH OF JOHN CHILD RAY

**Well-known Columbia Man Dies Suddenly at Phoenix, Ariz.—Popular in Talking Machine Circles Throughout the Country**

The talking machine industry learned with regret recently of the death of John Child Ray, who died at Phoenix, Ariz., a few weeks ago. Mr. Ray was well known in the talking machine trade, having been identified with the industry since 1903. His first position after leaving school was in the shipping department at the Columbia Graphophone Co.'s factory, Bridgeport, Conn. He filled various executive positions at the factory until February, 1912, when he was brought to New York as an assistant to H. L. Willson, now president of the company. He remained with Mr. Willson's staff until October, 1920, when, on account of poor health, he went to Pasadena, Cal.

After a rest of three months, Mr. Ray resumed active work on January 1, 1921, joining the sales promotion department of the Columbia Co.'s Los Angeles branch and doing excellent work under W. F. Stidham, manager of the branch. His never-failing ambition to further advance in the Columbia organization, coupled with his untiring energy, resulted in his almost complete breakdown in health, and necessitated his giving up business activities in March, 1922. He then went to Phoenix, Ariz., with the hope of regaining his health, but died there suddenly. While confined to his bed he made arrangements to open an exclusive Columbia shop in Phoenix, Ariz., which was scheduled for opening on June 20.

Mr. Ray is survived by a widow and two children, together with his parents. H. B. Ray, his father, is one of the veterans of the talking machine industry, and at the present time is associated with the Manufacturers Phonograph Co., New York.

## VICTOR SCHOOL IN NEW HAVEN

NEW HAVEN, CONN., July 8.—Arrangements have been completed for holding the classes of the Victor school of salesmanship in this city, according to an announcement made by E. C. Gallo, head of the Horton-Gallo-Creamer Co. The sessions will be held from July 31 to August 3 and salesmen who desire to take advantage of this opportunity are requested to notify Mr. Gallo.



WE ARE ALWAYS READY  
TO HELP YOU MR. VICTOR  
DEALER ALONG CONSTRUCTIVE  
PRACTICAL LINES

## A Significant Trade-Mark

The world famous Victor trade-mark, symbolic of Victor supremacy and leadership, is the Victor dealer's greatest asset and protection.

Mickel Service is offered to the Victor dealer as a means of thoroughly capitalizing Victor strength and prestige.

MICKEL BROS.



# *We Finance Your Radio Sales*

No doubt, you would like the following questions answered:

1. **Should I stock radio?**
2. **If so, what lines should I handle?**
3. **Will I be left "holding the bag" on some of the present-day goods?**
4. **Where is my protection on entering this new field, which seemingly assures large profits, but, to me, has no guarantee of permanency?**
5. **Will I have to stock a line of accessories?**

*Extract from an article by Mr. R. F. Yates, Editor "The Evening Mail" Radio Review, appearing under date of July 1, 1922.*

"The writer has given this matter considerable thought and is of the opinion that the phonograph dealers are best fitted to handle complete radio receivers. They have the booths all ready for their patrons and, furthermore, they are thoroughly acquainted with the sales plan, under which the more expensive radio receivers will eventually be sold. Reference is made to the time-payment plan."

## **Here Are Your Answers**

We will place in your stock a demonstrating line of Prima radio receiving apparatus retailing *complete with all batteries, tubes and other accessories*, from

**\$30.00 to \$250.00**

You pay us the usual dealer's price, with regular discounts allowed, as is customary in the talking machine trade.

## **Sales Guaranteed**

You sell these efficient, complete and among the best receiving sets on installment terms. We will take up the installment paper on each and every sale.

## **Sell on Installments**

No cost to enter—No accounts or stock to carry—Every sale means profits. We will ship you the demonstrating set, or sets, on regular or installment terms, and sales will be guaranteed.

## **The Best Dealers in Every City**

This opportunity is open only to live, progressive, up-to-date merchants. Territory will be restricted.

*Act quick—Wire or write your offer.  
Enter the Radio Field without gambling.*

**Prima Radio Corp.,** 185 Twenty-second Street  
Brooklyn, N. Y.



It's three O' clock in the morn - ing, We've danced the whole night thru.

**THIS YEAR'S BIG WALTZ HIT IS**

**"Three O'Clock in the Morning"**

**That Entrancing Melody You Hear Everywhere**

*"You can't go wrong with any Teist song"*

**HEAR IT NOW**



### ATLANTA DEALERS LOOK TO FALL

Business Marks Time Until Crop Returns Materialize—Jesse G. Bowen Piano Co. to Open "Talker" Department—Month's News

ATLANTA, GA., July 10.—This Southeastern district is so largely agricultural that except in the larger cities and towns the talking machine business is marking time. The large returns from crops do not come until Fall. Dealers are, however, already planning for the coming season.

In Greensboro, N. C., the Frazier Piano Co. will shortly move into a fine new store and will push talking machines more aggressively than ever before.

The Jesse G. Bowen Piano Co., of Winston-Salem, N. C., is completing a new building and has made its plans to open a well-arranged talking machine department, featuring the console type.

Geo. F. Alexander has opened a large music store in High Point, N. C., featuring the Victor and Brunswick. He was formerly located at Roanoke, Va.

Many Victor dealers throughout this section are taking on the Console cabinet equipped with Victor VI and thus have a true period, flat-top console model to sell at a reasonable price.

M. E. Lyle, representing the Strand, has been absent for several weeks looking after his trade through North Carolina and later going on to New York to visit the executive office of the Manufacturers Phonograph Co. He has been successful in opening new Strand accounts in many towns.

P. C. Brockman has returned from a trip North, his time being chiefly spent at the offices of the General Phonograph Co. Mr. Brockman is in charge of the wholesale phonograph division of the Polk Furniture Co., Atlanta, Okeh record distributor.

Westervelt Terhune, Columbia branch manager, has just returned from a brief visit to the company's executive office in New York. Mr. Mohl, assistant manager, has been off to Florida, looking after the company's interests there.

I. M. Bame and Leroy Webb, who have been with the Shriners on their long jaunt to the Pacific Coast, have returned home to this city.

The Cable Piano Co. recently decorated its large show window to represent a forest camp. The floor was carpeted with sand and rocks. Pine trees formed the background. Near the tent was a camp fire all ready for service. Displayed most appropriately were small Victor models. This clever window trim made an attractive sales appeal.

Very handsome and timely Fourth of July window decorations were featured by the Phillips & Crew Piano Co. and the Goodhart-Tomkins Co.

### FIRTH EXECUTIVES VISIT TRADE

P. A. Wilkinson Calling on Western Trade—H. E. Brennan Spends Several Days in Boston

P. A. Wilkinson, vice-president of John Firth & Co., New York, N. Y., manufacturer of Firth wireless telephone products, who is now making an important trip through the Middle West, has appointed several jobbers and full details regarding these appointments will be announced in the course of the next few weeks.

Herbert E. Brennan, secretary and sales manager of the company, spent several days in Boston recently in conference with Robert E. Steinert, of the M. Steinert & Sons Co., distributors of the Firth product. Mr. Brennan states that the outlook in New England territory is very satisfactory, and while in Boston managed to spend a half day on the links under Mr. Steinert's able supervision.

### A. H. CURRY ON SOUTHERN TRIP

ORANGE, N. J., July 14.—A. H. Curry, vice-president in charge of the phonograph division of Thomas A. Edison, Inc., leaves to-morrow on a Southern trip, during which he will look over his wholesale and retail phonograph interests in Texas. In addition to visiting Dallas and other cities in Texas, Mr. Curry plans to call on Edison jobbers located in Indianapolis, St. Louis, New Orleans, Atlanta and other points. He expects to return to Orange by the end of July.

### EDISON WINDOW DISPLAY FOR AUGUST

Music and Flowers Principal Theme of This Very Attractive Window Arrangement

The Edison window display service put out by Thomas A. Edison, Inc., for the benefit of new Edison dealers is moving ahead very fast. An increase in the demand for it of 33 1-3 per cent occurred in July, as against the previous month. This remarkable growth is attributed by the Edison organization to two things: First, the



The Edison August Window for Dealers fact that Edison dealers are anxious to use every worth-while plan for securing additional customers, and, second, to the fact that the service itself has been recently greatly improved.

Thomas A. Edison, Inc., has prepared a very attractive window for the use of Edison dealers in the month of August. The principal theme of this window is music and flowers, and every effort has been made to portray the scenes which are most appealing to those who derive the most pleasure from the Summer season. The center of the display is built around the Re-Creation "Hearts and Flowers," by Walter Chapman. The other selections featured are "Serenade—Les Millions d'Arlequin," by Albert Spalding; "Carnival of Venice" and "As Once in Happier Days." Walter Scanlan is the subject of the portrait in the upper center of the window.

### ANDREWS WITH OKLAHOMA T. M. CO.

OKLAHOMA CITY, OKLA., July 6.—The Oklahoma Talking Machine Co. has added to its staff Warren Andrews, who has had a varied Victor retail experience. He has been connected with the Oklahoma Talking Machine Co. for some time in the past in various capacities familiarizing himself with the general wholesale business. He has been assigned to no particular territory, but will travel chiefly in Oklahoma. In addition to P. A. Ware, sales manager, who will spend most of his time in the field in dealer development, this gives the Oklahoma Talking Machine Co. three representatives on the road.



### The "VICSONIA" REPRODUCER

For Perfect interpretation of Edison Disc Records on Victrolas and Grafonolas.

Fitted with permanent jewel point. No loose parts.

*Meet the demand—Serve your customers*

Sample Model "A" or "B" Vicsonia, nickel plated, will be sent on receipt of \$4.50. Retail price \$7.50.

Note: Model "B" Vicsonia plays both Edison and Pathé records.

VICSONIA MFG. CO., Inc.

313 E. 134th STREET

NEW YORK, N. Y.



# GLEANINGS *from the* WORLD *of* MUSIC

## INTRODUCE NEW TITLE DISPLAY DEVICE FOR ORCHESTRA

Will Aid the Sales of Talking Machine Records, Player Rolls and Sheet Music in Most Effective Way—Device Entitled Songtitleograph—Being Used by Vincent Lopez and Others

We have at various times since the opening of this department outlined plans by which orchestras could aid directly the sales of talking machine records, player rolls and sheet music. Our contention invariably was that the display by the orchestra of the title of the numbers being played would be of considerable value to the manufacturer and retailer, as well as the public.

We must confess that although there have been a number of schemes devised to encourage orchestras to carry out such plans they have not, to any extent, proved successful. Most orchestras believe that if they play a given number they are doing all they are obligated to do. The publisher, naturally, is not in a position to dictate the methods by which selections are programmed, but must be satisfied with the fact that he induces the orchestra to play a number from his catalog.

The retailer, however, is not obligated to the orchestra as is the publisher and he can, where his relationship will allow, bring pressure to bear and often persuade the orchestras of his city to carry out some plan of displaying the titles of the numbers rendered.

The latest innovation along these lines, which marks an important step forward in the announcing of titles by an orchestra, was that inaugurated by Vincent Lopez and his orchestra at the Pennsylvania Hotel, New York City. Mr. Lopez is ever on the alert to make his organization one of the leaders in its field and he spares no time or expense to carry out new ideas and to render service.

This new Lopez method consists of an electric sign above the orchestra stand which registers the titles of the numbers as they are being played. It is operated automatically, with the titles of the various numbers being flashed from a series of slides which are set in motion by the pressing of a button. The machine holds as many as 100 titles, which are operated in rotation, and by pressing the shift button two seconds before the end of the selection the title of the following piece is flashed by the time the introduction is taken up. The machine is known as the Songtitleograph and Mr. Lopez controls full selling rights.

By its use the orchestra not only offers a distinct novelty, but renders to its clientele a service that, once inaugurated, will, we believe, be difficult to discontinue. From the commercial standpoint it has exceptional value. The dance enthusiasts receive, in addition to the melody, the title of the number which they have received more or less favorably, leaving them in a position to call on the retailer for the record, roll or sheet music if desired.

Following the initial expense of the installation of this electric machine the cost of maintenance is quite low and we believe that there are possibilities of the device being installed by at least one leading orchestra in every large city.

### "ROMANY LOVE" SHOWS UP WELL

New Sam Fox Number Proving an Active Summer Offering

Early this Spring Sam Fox, head of the Sam Fox Publishing Co., brought East with him a manuscript copy of "Romany Love." He believed he had a number of big possibilities. He had no idea, however, that "Romany Love" was to prove one of the most popular of the Summer offerings. However, shortly after the release of the song in New York territory it made an impression on the various recording rooms which are this year particularly looking for hits—something to create activity and add to sales. Mr. Fox was induced to give the leading orchestras manuscript copies of the number until he could rush through the printed orchestrations. All of which resulted in "Romany Love" finding much favor.

A special orchestra arrangement similar to that made for the Paul Whiteman organization has now been printed and sent to the prominent orchestra leaders and the original band arrangement made for John Philip Sousa has been printed and forwarded to the larger bands. Regular orchestrations, band and vocal copies are now ready and the Sam Fox organization has inaugurated one of the most elaborate campaigns ever arranged for a popular song.

It must be remembered by those who are interested in the success of this method of programming—and every one selling records, rolls and sheet music is interested—that if this plan is taken up by a sufficient number of orchestras the musical combinations of lesser caliber will be forced to display the titles they are playing. Of course, in every instance the smaller orchestra would not be able to carry the expense, but there are many less costly methods of displaying titles which can and, no doubt, will be used if the idea makes the progress its importance justifies.

It might be said in closing that the Songtitleograph now being used by Vincent Lopez and his orchestra is the third machine of this character that has been tried out by him. He conceived the idea many months ago and experimented extensively before completing the successful device now used nightly on the Pennsylvania Roof.

### TO REVIVE "SOME OF THESE DAYS"

New Arrangement to Be Introduced by Sophie Tucker on Her Return From Europe

CHICAGO, ILL., July 8.—Will Rossiter announces that the big-time hit, "Some of These Days," is to be revived with a new arrangement and placed on sale all over the country. It has practically been decided that Sophie Tucker will introduce the new arrangement of this song upon her return from her present European tour.

Incidentally, we might mention, in passing, that the two big present Rossiter numbers, "Those Longing-for-you Blues" and "In Bluebird Land," are selling in a most satisfactory way in Chicago. The Six Brown Brothers have been featuring "In Bluebird Land" at all Ballaban & Katz theatres and will return to Chicago next week. Will Rossiter has a man now in New York plugging on "Those Longing-for-you Blues." It is already out on a number of records and bids fair to be a remarkable success.

M. J. Mintz, president of the Cameo Music Pub. Co., announces that through an arrangement with Jack Loeb, manager of the William Fox Theatres, Catherine A. Borland's "The Voice From Calvary" will be featured in all the Fox theatres on the first anniversary of Caruso's death, August 2.

*Now Ready-Records of the Smashing Blues Hit*

# Lonesome Mama **BLUES** FOX TROT

*Records by almost every talking machine Co*

The demand promises to be tremendous  
Order your supply now—and liberally

*Published by J.W. JENKINS Sons' Music Co Kansas City, Mo*







My pret-ty Bir-die — my heart is say-ing: it's June, — Just like an old hur-dy gur-dy,

# BIRDIE

A Sweet-Tweety Fox Trot Song by Jesse Crawford

HEAR IT NOW!

"You can't go wrong With any FEIST song"

**SUIT OVER "GALLAGHER AND SHEAN"**

It is quite the usual thing when a song becomes a national hit to hear the charge of plagiarism or the entering of a suit charging that the whole or part of the melody is an infringement. The latest action of this sort is that instituted by Bryan Foy, in private life Bryan Fitzgerald, alleging that he wrote the song "Mr. Gallagher and Mr. Shean" in May, 1921. The vaudeville team of Gallagher and Shean are made defendants and Jack Mills, Inc., the publisher, co-defendant.

**IMPROVEMENT IN WINDOW DISPLAYS**

Sheet Music Retailers Giving More Attention to This Form of Publicity—An Interesting Recent Example in Weymann & Son Store

As remarked some time ago in these columns, there has, during the last twelve months, been a decided improvement in window displays of both sheet music and talking machine records, thus showing that the retailer has come to realize the great advertising value an attractive window display offers.

Much credit, we think, for this advance in window arrangements belongs to such houses as Lyon & Healy, J. W. Jenkins' Sons Music Co., Sherman, Clay & Co., H. A. Weymann & Son, Inc., and others of like caliber, who seem to have led the way in this connection. Their pioneering, as it were, has had a very large and exceedingly favorable response in retail circles.

The above brings to mind an attractive display recently shown in the Chestnut street window of the Weymann store in Philadelphia, a reproduction of which is shown herewith. Here is, undoubtedly, one of the most elaborate displays of the past twelve months. The Victor record

of "Three O'Clock in the Morning," and the sheet music of the number (Feist), as well as player-rolls of the same selection, are all shown, and of particular importance is the fact that the display of the merchandise seemingly does not intrude upon the setting. In other words, the ball-room scene, with figures of a boy and girl dancing, and an artistic clock denoting the hour of 3 a.m.,



Weymann Window Display of Feist Hit

attract the attention and arouse the interest. The merchandise, seemingly, is supplementary, but those who are attracted, undoubtedly, get the message intended without in any way feeling that they have been imposed upon by the commercial activities of the house—an important psychological point.

**ARTHUR J. LAMB'S LATEST EFFORT**

Veteran Songwriter Collaborates With J. S. Zamecnik in "Romany Love"

It has often been said, particularly in sporting circles, that "they never come back" and there has been some basis for believing that that maxim applies to the writers of songs, but, while this may be true in general, there is evidence in several instances that a writer's vogue may last at least twoscore years.

Arthur J. Lamb, who wrote "Asleep in the Deep," has, from time to time since, contributed other offerings, though none seems to rival that number for which he is chiefly known. It is quite surprising, then, to find his name linked as collaborator with J. S. Zamecnik in the current fox-trot and song success, "Romany Love," issued by the Sam Fox Pub. Co.

Recently was instanced a case or two where publishers who did not recognize a Summer depression were cashing in heavily on the sale of songs through their Summer activities. Among such publishers is the house of Fox, which

operates upon the basis that if you have the goods of merit and create a demand for them the public will buy. An almost overnight recognition of "Romany Love" seems to prove the contention.

**GORDON V. THOMPSON RECOVERING**

Canadian Manager of Leo Feist Convalescing—Dealers Tie Up With Movie, "Smilin' Through," and Boost Sale of That Number

TORONTO, CAN., July 6.—Gordon V. Thompson, Canadian manager of the Leo Feist Co., this city, has been very ill the last two or three months, with a complication of troubles. Mr. Thompson's personality, good-fellowship and general likableness have endeared him to the trade and everybody will be very glad when he is able to be back at his desk.

The moving picture, "Smilin' Through," is playing at the Allen Theatre, and those sheet music dealers who have hooked up with this picture have been selling a satisfactory quantity of the song of that name published by M. Witmark & Sons.



**"ROMANY LOVE"**

The New Gypsy Fox Trot Song Hit

Featured by the prominent leaders while yet in manuscript and released on leading records and rolls before printed copies were available; by far, the quickest popular hit we have struck. Its appeal is instantaneous. Printed song copies and orchestrations now on sale at the low introductory price.

INTRODUCTORY TRADE PRICE 13½c. (12½c. in 100 Lots)

Extra Title Pages and Display Streamers Supplied with Every Order

Published by

**SAM FOX PUB. CO.**

Cleveland, O. U. S. A



**TO MANAGE BRUNSWICK ARTISTS**

Arthur Judson in Conjunction With International Concert Direction to Book Artists for Coming Musical Season—Co-operating With Dealers

Wm. A. Brophy, managing director of the Brunswick recording laboratories, New York, announced recently with keen enthusiasm the fact that Arthur Judson, manager of the Philadelphia Orchestra and the New York Philharmonic Orchestra, is to undertake in conjunction with the International Concert Direction Incorporated Bureau the management of several Brunswick artists for the coming Fall and Winter musical season. The Brunswick artists who will come under this new arrangement are Claire Dux, Bronislaw Huberman, Marie Tiffany, Theo Karle, Siegrid Onegin and the Elshuco Trio, all well-known Brunswick artists who have made many recordings on Brunswick records. It is expected that under this new arrangement these artists will be given wide publicity throughout the country, and will be heard in most every prominent center during the coming season. Mr. Brophy stated that Brunswick dealers will be notified in advance of the appearance of these artists in their particular cities, and that the Brunswick Co. will do everything possible to co-operate with the dealer to the fullest extent, which no doubt will result in increased sales of the records of these artists and arouse an interest in Brunswick product generally.

**FOUR CONTRACTS RENEWED**

Witmark Organization Renews Contracts With Four Prominent Writers

Four noted and successful songwriters and composers have renewed their contracts with M. Witmark & Sons by which the firm acts as exclusive publishers for the quartet for a term of years. Included in these are Sigmund Romberg, the well-known composer of musical comedies, who last season had to his credit such productions as "The Blushing Bride," "The Rose of Stamboul," "Bombo" and "Blossom Time." Eubie Blake and Noble Sissle, of "Shuffle Along" fame, are also included in the list of renewals, as well as that contributor of unusual ballads of marked distinction, Arthur A. Penn.

**FOLDER OF O'HARA SONGS**

Ditson Co. Features Three of the Popular Songs of That Composer

The Oliver Ditson Co., Boston, has issued for the use of dealers an interesting little envelope folder devoted to the songs of Geoffrey O'Hara, two of them clever French-Canadian numbers for which William H. Drummond supplied the lyrics, they being "The Wreck of the 'Julie Plante,'" and "Leetle Bateese." Both these songs have proved distinctly popular among a large group of concert singers. The third number featured in the folder is a ballad, "Sweetheart, Do You Remember," for which May Stanley supplied the words.

**FEATURES GENNETT RECORDS**

DULUTH, MINN., July 8.—The McClure Music Co., of St. Paul, Minn., has taken over the music department of the I. Freimuth Co., of this city, and, in addition to the sheet music department, the former concern has installed a complete line of Gennett records. A window display of these records in connection with a vigorous campaign is showing excellent results.

J. Will Callahan, the blind composer, and his wife are spending the Summer at their home in Bay View, Mich. Mr. Callahan and his wife for the past several months have been sojourning down in Florida in an endeavor to recuperate Mr. Callahan's health. It is said that he has just finished a new number in collaboration with Lee S. Roberts and Max Kortlander.

**EDISON CONTESTANTS ENJOY TRIP**

Winners of Sales Contest Sponsored by Harger & Blish, of Des Moines, See Sights of Gotham and Visit Edison Laboratories at Orange

The prize-winning dealers of the sales contest recently put on by Harger & Blish, Des Moines, Ia., for the Edison dealers located in the territory which this company serves as an Edison jobber, started on their journey East to New York, and to the Edison laboratories, the early part of this month. They arrived at the factory and called on the Edison officials and went through the factory on Monday, July 10. Each prize winner was presented with a handsome autographed photograph of Thomas A. Edison and the whole party received a most cordial reception from the Edison executives throughout the day they spent in Orange. An attractive luncheon was served at the famous inn located on the mountain which lies back of the center of Orange. In the evening, as the guests of the Edison people, the visiting dealers were given a wonderful Italian dinner at Carrie's, the famous dining place of New York's Great White Way. Following the dinner party they were taken to "The Music Box Revue."

The prize-winning dealers who made the trip were: Division 1: Guy Cooper, S. E. Cooper & Son, Maxwell, Ia.; Division 2: F. M. Cooper & Son, Woodward, Ia.; Division 3: Harry C. Shroyer, Bethany, Mo.; Division 4: H. A. Lorenzen, Newcomb & Mathews, Creston, Ia.; Division 5: Ray Fude, Carl E. Schlegel Drug Store, Davenport, Ia.

On the way to the factory and on the return trip the party stopped off at several points of interest.

**TALKING MACHINE SPEEDS UP WORK**

Stimulates Men Working on Rebuilding of Mississippi Factory to Such an Extent That They Break Some Real Speed Records

MERIDIAN, MISS., July 5.—The value of the talking machine in speeding up the efforts of merchants was illustrated most forcibly recently in connection with the rebuilding of the big lumber plant of the Long-Pell Co., at Quitman, Miss. When the plant was destroyed by fire the general manager was instructed to use every available man and speed up rebuilding operations as rapidly as possible. Thirty days was set as the time limit.

THE SENSATIONAL NOVELTY  
FOX-TROT  
**THE FRENCH TROT**  
SHEET RECORDS ROLLS  
JOE MITTENTHAL · INC · NEW YORK



Work was started with two shifts of men working right through the twenty-four hours, and every effort was made to keep things moving. It was found, however, that the day shift accomplished much more than the night men, owing, probably, to the monotony of night work. The manager thereupon secured a talking machine and several dozen jazz records and kept a boy operating the outfit throughout the night hours. The result was that the night shift was able to lay 1,500 more bricks than was the record before music was furnished, and by actual comparison accomplished more than the day shift. The plant was entirely reconstructed in twenty days, or ten days within the time limit, and credit for the last work was given to the talking machine.

**MACINTOSH BROS. IN NEW HOME**

Handsome Victor Shop Equipped by the Unit Construction Co.

COLLINGSWOOD, N. J., July 8.—MacIntosh Bros., Victor dealers in Collingswood and Woodbury, N. J., announce the opening of their new store on Haddon avenue in Collingswood. In the new location MacIntosh Bros. will be able to give even better service to their many customers and the service department of the Unit Construction Co. has accomplished the equipment changes for them. Old ivory is the predominant tone in their new store, which has been attractively arranged to produce an effect which is sure to please customers.

ANOTHER "DOWN HOME BLUES" ON  
**BLACK SWAN RECORDS**



RECORD No. 14115

**"Ain't Got Nothin' Blues"**  
Soprano with Orch. by  
**Mary Straine**  
COUPLED WITH  
**"The Fowler Twist"**  
Baritone with Orch. by  
**John P. Vigal**



ORDER TODAY and let this record keep your Summer sales going big. IT'S A HIT!!!

**PACE PHONOGRAPH CORP., 2289 Seventh Ave., New York**



Made of High Grade  
Hardened Steel  
Specially Treated  
to Give  
Frictionless Surface

Reg. U. S. Pat. Off.  
No. 995758 which will  
be strictly enforced



Extra Heavy  
Size—1 1/8 in.



7/8 in.



3/4 in.



3/8 in.



1/2 in.



3/16 in.

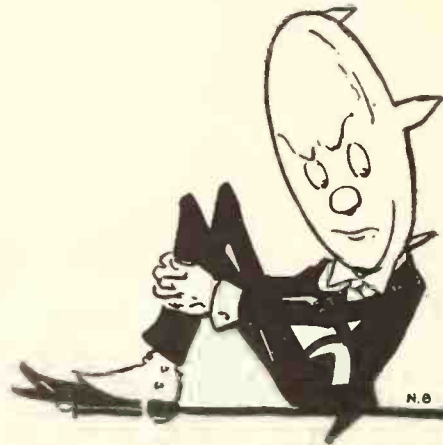

## Furniture Footwear

### Simplicity

Furniture footwear to give thorough satisfaction must be simple in character—otherwise it means trouble and dissatisfaction.

There is only one device that meets this specification

### DOMES of SILENCE

The perfect footwear for furniture.

Domes of Silence also have these additional qualities, which ordinary devices do not possess:

*Economy*

*Silence*

*Invisibility*

*Adaptability*—Suitable for covered and uncovered floors alike.

*Service*— Long wear.

Protection to furniture, floors and rugs.

The perfect footwear for furniture—

### DOMES of SILENCE

*"Better than Casters"*

Henry W. Peabody & Co.

DOMES OF SILENCE DIVISION

17 State Street, New York City

*In All Your Talking Machine Orders,*

**Specify DOMES of SILENCE**

F 63

*What we say above about Furniture applies also  
to Phonographs*



**RED SEAL CLASSES IN NEW YORK**

First Class Under Auspices of Victor Wholesalers of Metropolitan District Holds Sessions at Hotel Pennsylvania This Week With One Hundred in Attendance—Second Class Will Meet on Monday, July 17, at Same Place

The first of the Red Seal salesmanship classes under the auspices of the Victor Wholesalers of the New York metropolitan district, opened at the Hotel Pennsylvania on Monday of this week, July 10, and continued daily up to and including Thursday. About one hundred members of local retail sales organizations attended the classes, two sessions being held daily from 9 to 12 a. m. and from 2 to 5 p. m.

The course at the school was very similar to that covered at the Red Seal School in Camden, although in condensed form, and followed along the lines of the Red Seal classes that have been held in Buffalo, Washington and other cities. F. A. Delano, in charge of the Victor Co.'s classes in salesmanship at the factory, was in charge of the course, and among those who gave talks during the week was Mrs. Frances E. Clark, head of the educational department of the Victor Co.

Following the close of the school on Thursday afternoon those who attended the sessions were taken in automobiles to Brighton Beach where they enjoyed dinner and dancing at the Hotel Shelburne and later attended the vaudeville show at the Brighton Beach Theatre as the guests of the metropolitan wholesalers.

Although all the wholesalers co-operated in the holding of the classes the arrangements of the details for the school were in the hands of a committee consisting of J. Newcomb Blackman, of the Blackman Talking Machine Co.; L. L. Spencer, of the Silas E. Pearsall Co., and Charles B. Mason, of the New York Talking Machine Co.

Beginning next Monday, July 17, the second and final class will begin its sessions at the Pennsylvania with a registration of about seventy-five. The second class will end on July 20 and the course will be the same as that of the first class.

**LUDWIG & CO. ENLARGING STORE**

WILKES-BARRE, PA., July 10.—The Simon Long Building, headquarters of Ludwig & Co., talking machine and musical instrument dealers, is being remodeled in order that the enlarged business of the concern can be taken care of in an efficient manner. The company is considered the largest house in this section of the State, and when the alterations are completed it will be one of the most attractive in the East. The remodeling includes the installation of a number of booths for record demonstration purposes, new show cases, larger window space, etc.

**GETTING AFTER THE NEWLYWEDS**

Cline-Vick stores in Indiana send special and attractive cards of congratulation to all newly

**JOY and HEALTH to the BRIDE and GROOM**  
 WE WILL SAVE YOUR VICTROLA UNTIL AFTER THE HONEYMOON



Cleverly Designed Greeting Card married couples in the towns where their stores are located and incidentally offer suggestions that mean Victrola sales.

The Ideal Furniture Co., of Hazard, Ky., Columbia dealer, is planning to move into a new five-story building about September 1.

**INSPIRING BUSINESS TALKS**

Metropolitan Victor Dealers Enjoy Talks by J. T. Lange, Abram Davega and J. W. Schwetz at Knickerbocker Co. Meeting in New York

The Knickerbocker Talking Machine Co., Victor distributor, New York City, invited metropolitan Victor retailers to attend a lecture in the concert hall of the company at 138 West 124th street, on Thursday, July 6, at 2 p. m. Joseph T. Lange, educational manager of System Magazine, talked interestingly on "Salesmanship in Selling Merchandise," and gave many valuable suggestions that were applicable to the talking machine retailer in the conduct of his business.

Previous to Mr. Lange's talk Abram Davega, president of the company, spoke on "Selling Good Business." He said in part: "You, yourself, have got to be sold on good business, and I am sold on this idea. I know that there is absolutely nothing the matter with business conditions." Mr. Davega pointed out how the dealer who was sold on the idea of good business was far better

equipped to overcome obstacles and urged the spreading of this doctrine. He analyzed conditions leading up to the present time and told of a letter recently received from the Victor Co. stating that students of business conditions say that the 1922 Fall season will be the best business season we have had in two years. "If things are slack during the Summer don't give up and go away for a two months' rest, but just knuckle down to business and plan out a systematic campaign," stated Mr. Davega. "There are hundreds of good business ideas. You have to be sold on good business before other ideas can be carried out to improve your business."

Another talk which was intensely practical and inspiring was given by Joseph W. Schwetz, vice-president of the Knickerbocker Talking Machine Co. Although thoroughly experienced in the talking machine business from both the retail and wholesale angles, this is said to be Mr. Schwetz's first speech. The subject was "How to Conduct Your Business," and represented Mr. Schwetz's twenty years' experience in talking machine merchandising.



Patent Pending  
 Size: 8 in. x 14 in.  
 x 15 in.  
 Weight: Complete,  
 including album,  
 22 lbs.

*"One handle handles it"*

# Outing

## TALKING MACHINE

Perfection in a Portable Phonograph

Made in Mahogany and Fumed Oak Finishes

THE OUTING is the most complete and up-to-date portable phonograph ever made.

It is unique and attractive in design. Superior tone quality. Built to give years of satisfactory service.

**JOBBERS:**

- |  |  |  |  |
|--|--|--|--|
| <p><b>GENERAL PHONOGRAPH CORP.</b><br/>                 New York Distributing Division<br/>                 15 West 18th Street<br/>                 New York, N. Y.</p> <p><b>CABINET &amp; ACCESSORIES CO.</b><br/>                 145 East 34th St.,<br/>                 New York, N. Y.</p> <p><b>BRISTOL &amp; BARBER</b><br/>                 3 East 14th St.<br/>                 New York, N. Y.</p> <p><b>THE GRAFONOLA CO. OF NEW ENGLAND</b><br/>                 174 Tremont St.,<br/>                 Boston, Mass.</p> | <p><b>GEO. C. ULRICH &amp; CO.</b><br/>                 718 Lincoln Bldg.,<br/>                 Philadelphia, Pa.</p> <p><b>A. J. HEATH &amp; CO.</b><br/>                 27-29 So. 7th St.<br/>                 Philadelphia, Pa.</p> <p><b>IROQUOIS SALES CO.</b><br/>                 210 Franklin St.,<br/>                 Buffalo, N. Y.</p> <p><b>UTICA'S GIFT &amp; JEWELRY SHOP</b><br/>                 Utica, N. Y.</p> <p><b>DAVENPORT PHONO. &amp; ACCESS. CO.</b><br/>                 217 Brady St.,<br/>                 Davenport, Ia.</p> | <p><b>VOCALION CO. OF OHIO</b><br/>                 Cincinnati, O.</p> <p><b>VOCALION CO. OF OHIO</b><br/>                 Cleveland, O.</p> <p><b>BURNHAM, STOEPEL &amp; CO.</b><br/>                 101 East Larned St.,<br/>                 Detroit, Mich.</p> <p><b>WALTER S. GRAY CO.</b><br/>                 942 Market St.,<br/>                 San Francisco, Cal.</p> | <p><b>J. K. POLK FURN. CO.</b><br/>                 294 Decatur St.,<br/>                 Atlanta, Ga.</p> <p><b>CANDIOTO PIANO CO.</b><br/>                 120 S. Limestone St.,<br/>                 Lexington, Ky.</p> <p><b>WM. ANDERSON PIANO CO.</b><br/>                 79 Eighth St., S.,<br/>                 Minneapolis, Minn.</p> <p><b>RICHMOND SPORT &amp; SPECIALTY SHOP</b><br/>                 (Newton Corp.)<br/>                 616 E. Broad St.<br/>                 Richmond, Va.</p> |
|--|--|--|--|

There are still several good States and large Cities open. Full details or samples will be furnished responsible jobbers on application.

# Outing

## TALKING MACHINE CO., Inc.

A. J. COTE, President  
 MT. KISCO, N. Y.

Dealers in Mexico and Cuba should send orders and inquiries to  
 R. C. ACKERMAN  
 291 East 162nd Street New York, N. Y.

Foreign Export—CHIPMAN LIMITED  
 8-10 Bridge Street New York City  
 Cable Address, CHPMUNK, New York





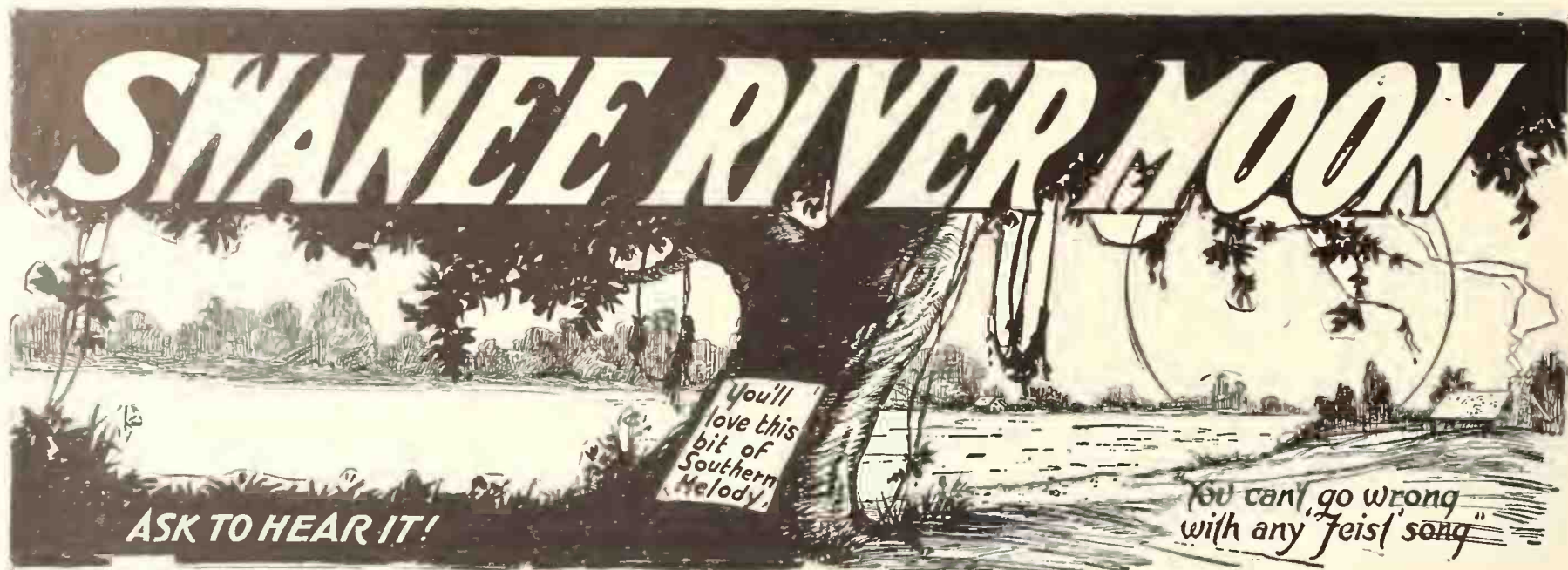

# BALTIMORE

*Portable Machines Have the Call—C. B. Noon's Enterprise—Or-  
dinance to Muzzle Talkers—Trade Outlook Improves—The News*

BALTIMORE, Md., July 10.—While business, generally speaking, is quiet, dealers here are satisfied with the business being done and have no cause for complaint. The demand for small portable machines by campers and vacationists is reported as exceeding the supply and in addition quite a number of the larger types of machines are being sold. Manager Roberts, of E. F. Drake & Sons, said his business for the last four weeks was 20 per cent ahead of the corresponding period of last year and the way business had started in this month so far he figured on also beating last July's record. Both the other Victor agencies, Cohen & Hughes, and Eisenbrandt's, also report a fair business being done and a good demand for the popular records.

Sales of portable machines have been greatly stimulated by the advertising being done in the daily papers here, featuring these instruments.

The Columbia branch here reports difficulty in keeping up with the sales of portable machines and it is by no means a dull season for the regular line of Grafonolas. This company has also been doing some extensive local newspaper advertising and is helping dealers to organize outside sales forces. Business is reported exceptionally good on records on Saturdays in the western part of the city, but quiet in the eastern section.

#### Loans "Talkers" to Sick in Hospital

The importance of music as a factor contributing to the rapid recovery of those convalescing from illness has been demonstrated twice recently in this city through the courtesy of C. B. Noon, president of the C. B. Noon Co., Inc., who loaned a talking machine to two patients at Johns Hopkins Hospital. Some weeks ago

Mr. Noon was asked to rent a machine to a woman patient who was in the local hospital to undergo an operation. He placed a machine in her room without charge and the same day relatives of the patients called at the Noon establishment and purchased a large number of records.

When the woman left the hospital she personally called upon Mr. Noon to thank him. About the same time one of the other patients made the request that the machine be loaned to her and Mr. Noon complied. Another supply of records was sold.

With his customary enterprise, Mr. Noon now is making plans to put machines in the other hospitals of the city.

#### Voluma Corp. in New Home

The Voluma Corp., of this city, patentee of the Voluma reproducer, has rented the store at 317 North Howard street and is giving daily demonstrations of the instrument.

#### Effective Work in Schools

The work of Miss Margaret R. Martin, educational representative, who has been working in the local territory, has met with great favor among the universities and schools of Virginia and North Carolina, and letters received at the Baltimore branch office indicate that educators with whom Miss Martin has worked have been most agreeably surprised at the wealth of educational material available for Columbia dealers.

#### Fine Grafonola Business

Lester B. Harvey, at Oakville, Va., depends entirely on country trade for his Grafonola sales. When competition began to root for depression in business Mr. Harvey put in his efforts boosting and selling. Results are very gratifying. It is the belief of both Mr. Harvey and the Columbia

branch that the healthy business being done under present conditions will continue to show a steady, wholesome growth. What better commentary on the success of the carload sale than to note that W. T. McCoy, of Charlotte, N. C., whose carload sale last December netted 111 Grafonolas, is now enjoying a well-earned vacation in Atlantic City, N. J.

#### Flood Damages Bristol Store

Gutman's, Inc., of Bristol, Va., was nearly inundated by the recent big flood in that section. Water on the first floor was deep enough to float a boat in, although sand bags, piled breast high across the doorway, acted as a dike. Their store warehouse, however, was in the deepest part of the flood and suffered considerable damage. Walter J. Boggs, the general store manager, reports that swimming suits and waterwings were the order of the day.

#### Changes in the Trade

William H. Swartz has succeeded J. H. Marshall as head of the Dealers' Service Bureau of the local branch of the Columbia Co. and has some new idea along this line which he intends to put into operation in the near future. H. W. Webb Peptor has been made manager of the dictaphone department of this agency.

#### Would Muzzle "Talkers"

A city ordinance muzzling talking machines, horns and other musical instruments and devices used for advertising purposes was favorably reported to the Second Branch City Council this week by the Police and Jail Committee. It was laid over, under the rules, until the Fall meeting of the Council. The purpose of the ordinance, which carries penalties ranging from \$25 to \$100, is to prevent stores selling musical instruments from disturbing people on the highways and in office buildings by "continuous noises."

A number of stores have been using talking machines with large horns in the doorways of their stores and running the same continuously all day. This brought a number of complaints from business houses in the vicinity of these places to the police and resulted in the introduction of the above ordinance.

#### Receiver for Setchell's Song Shop

Judge Rose, of the United States District Court, signed an order this week adjudicating George W. Setchell and Mary E. Setchell, individually and as co-partners, trading as Setchell's Song Shop, 332 North Howard street, bankrupts, and appointing Joseph M. Hasselhoff receiver for their business, fixing his bond at \$4,000. The orders were signed upon a petition filed by the R. F. Volland Co. and others, alleged creditors.

#### Talking Machine Shop Chartered

Talking Machine Shop, Inc., 704 Union Trust Building, has been incorporated with a capital stock of \$25,000; 250 shares preferred stock, par value \$100 and 100 shares common stock without par value. This company is incorporated to deal in talking machines, etc. Incorporators are Francis S. Harris, Allan H. Fisher and Morton P. Fisher.

We Are Now DISTRIBUTORS for the

## Swanson Portable Phonograph

The most compact, up-to-date portable on the market.

Wooden tone-arm, Heineman No. 36 double spring motor—weight only 15¼ lbs.

For further details regarding the Swanson Portable Phonograph see page 25

Write today for dealer proposition

### CABINET & ACCESSORIES CO.

145 East 34th Street

NEW YORK



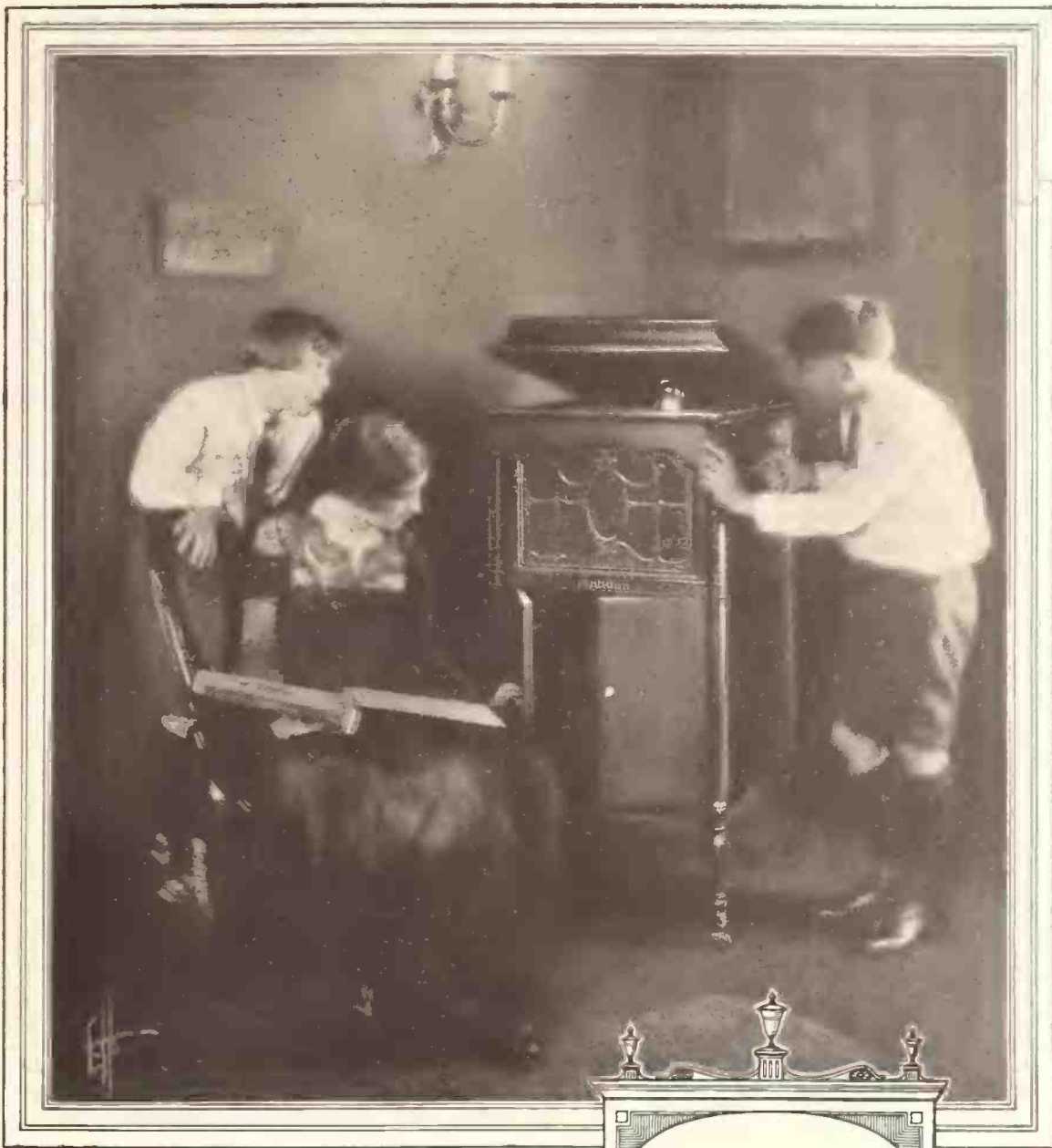

SHERATON  
MODEL 8

*The Widdicomb Sheraton model illustrated is finished in Red or Antique Mahogany, or Walnut, and is equipped with albums for records, automatic stop and patented tone control. Widdicomb Phonographs play all records. All Widdicomb models are now selling at pre-war prices. New prices range from \$90 to \$260.*

**W**IDDICOMB Phonographs are distinguished alike for their exquisite cabinet work and for their beauty of tone. Their artistic period designs are the handicraft of an organization which for three generations has enjoyed a deserved reputation for leadership in fine furniture building. Their tonal beauty and faithfulness in reproducing recorded music have been perfected by years of painstaking research. Naturally they have won an unusual prestige among discriminating buyers. It follows as a matter of course that merchants with the Widdicomb franchise are accorded the esteem and patronage of the best class of trade. If you are genuinely interested in building up your business among this class of buyers, write for catalog and detailed information regarding the Widdicomb franchise.

THE WIDDICOMB FURNITURE COMPANY

Grand Rapids, Michigan

*Fine Furniture Designers Since 1865*

*Widdicomb*  
PHONOGRAPH  
*The Aristocrat of Phonographs*



# DETROIT

*Business Is Normal—Collections Improve—The Radio Situation—Some Notable Changes*

DETROIT, MICH., July 10.—Business is normal in the talking machine field. Nobody reports a very brisk trade, yet most dealers have apparently enjoyed more than average trade for the past month. July and August are expected to be in the same class as June and dealers are looking for a good Fall trade. It's the same old thing every year, according to one dealer. The same months are good and the same months are dull, year in and year out. The one outstanding feature of trade conditions for the past month was the great improvement in collections, which is a very healthy sign and indicates that people have money. This is certainly true in the city of Detroit, as people have been working, wages have

been good and employment steady since last March. The outlook that such a condition will continue is very bright. Motor car factories have more orders than they can fill and this will obtain for at least another three or four months, if not longer.

### Radio Demand Loses "Pep"

The radio, which has been worrying some of our dealers, seems to have lost its "pep." At least that's the report we get from dealers in radio outfits and supplies. There doesn't seem to be near the interest in radio to-day that there was two months ago. It may be due to the warm weather. Dealers do not even attempt to predict that it will come back again in the Fall. "It's not as good as a talking machine" is the way one person expressed it who had gone to the expense of installing a \$500 outfit in his home. "The beauty of the talking machine is that you can put on a record whenever you want to, whereas with the radio you have to sit and wait and you can only get entertainment for several hours and then it usually comes between six and seven when you want to eat your supper."

### Fine Vocalion Business

Sam Lind, of Lind & Marks Co., distributor of the Vocalion, says that business for the first six months has shown a very fine increase over the same period of last year and that new dealers are being taken on every week and that the old customers are increasing their orders. Record business, he adds, is exceedingly good for this season of the year.

### Music Memory Contest Creates Interest

The Music Memory Contest continues to create great interest among local music houses. The contest is sponsored by the Detroit News in co-operation with the Detroit Talking Machine Dealers' Association and the whole city seems to be manifesting an interest in it. The stores that have joined into the spirit of the contest with vim and vigor are The Edison Shop, Grinnell Bros., J. L. Hudson Music Store, Detroit Music Co., Gardner-White Co., Reich Music Store, Waite Music Co., and the Peoples Outfitting Co. These stores are giving concerts every week, changing the program each week, and the attendance at the recitals is surprising.

### New Edison Records Daily

An interesting announcement appears in the window of The Edison Shop to the effect that new records arrive daily. In other words, instead of releasing twice a month as other companies do, The Edison Shop releases new records as fast as they come in so that every day there is something new to offer. R. B. Alling, general manager, states that retail business is holding its own for this time of the year and that wholesale business, which is conducted through the Phonograph Co. of Detroit, is also normal, with new accounts being opened steadily.

### Doran Phonograph Co. to Move

Henry Doran, of the Doran Phonograph Co., Victor dealer, who for many years has been located on Michigan avenue, says that he expects to close definitely for his new store during the present week. His lease expires August 1 and he must vacate at that time as the building is to come down.

### Jewett Plant Speeds Up to Fill Orders

A. A. Fair, of the Jewett Phonograph Co., states that business has been very good the past few months, and that the factory at Allegan, Mich., is further oversold than at any time this year. In addition to the regular Jewett line the company is now producing a combination radio-phonograph which is selling faster than the factory can produce it. The company has extensive plans in mind for enlarging the factory, and hence production. Mr. Fair has been East most of the past four weeks and has been meeting with big success everywhere in securing new business.

### TAKE ON COLUMBIA LINE

Salano Bros., proprietors of the Murray Hill Music Store, located at Forty-fifth street and Second avenue, have recently added the Columbia line to their stock. They will specialize in Italian records.

## NEW EDISON RE-CREATION CATALOG

Latest Edition Is Second Volume Issued—More to Follow in Consecutive Volumes

Thomas A. Edison, Inc., recently issued volume two of the Edison Re-Creation Catalog, which is, in fact, a Re-Creation stock book as well as the Edison Re-Creation catalog. It is the plan of the Edison Co. to issue succeeding catalogs in consecutive volume form, so that the Edison dealers will secure the complete library by assembling the different volumes as fast as they are received, each new volume not in any way superseding the previous editions, but being supplementary thereto. This plan obviates the necessity of transferring the inventory and sales data contained in the previous editions.

## VICTOR EDUCATIONAL ACTIVITIES

Members of Educational Staff of Victor Talking Machine Co. Carrying on Work in Many Parts of the Country During Summer

PHILADELPHIA, PA., July 7.—These are busy days for the staff of the Educational Department of the Victor Talking Machine Co., the members of which are for the most part busy attending conventions of teachers and music supervisors in various sections of the country. Mrs. Frances E. Clark, head of the educational department, attended the National Educational Conference held in Boston recently, later going to New York to address the salesmanship classes in that city. Miss Edith M. Rhett is giving a course of instruction during the Summer at the Northwestern University in Evanston, Ind. Miss Margaret M. Streeter is in the South attending various educational gatherings.

Miss Bess Daniels recently gave a three weeks' course in music at the Latter Day Saints' University in Salt Lake City and is now in Colorado. Miss Marie Finney and S. Dana Townsend are in the Middle West. Robert J. Coleman is visiting the normal schools in Virginia and West Virginia and Miss Mabel Rich is in Europe on vacation.

Two new members of the educational staff are Miss Alice Keith, of Chicago, an authority on pageants, and Dr. Esther L. Gatewood, of Connersville, O., who has a wide reputation as a lecturer on philosophy.

## APPOINT NEW YORK REPRESENTATIVE

The American Musifer Co., recently incorporated in the State of Delaware with a capital of \$3,000,000, has certified to the Secretary of State that C. J. Kilber, 167 West Sixty-fourth street, New York, will represent the corporation here.

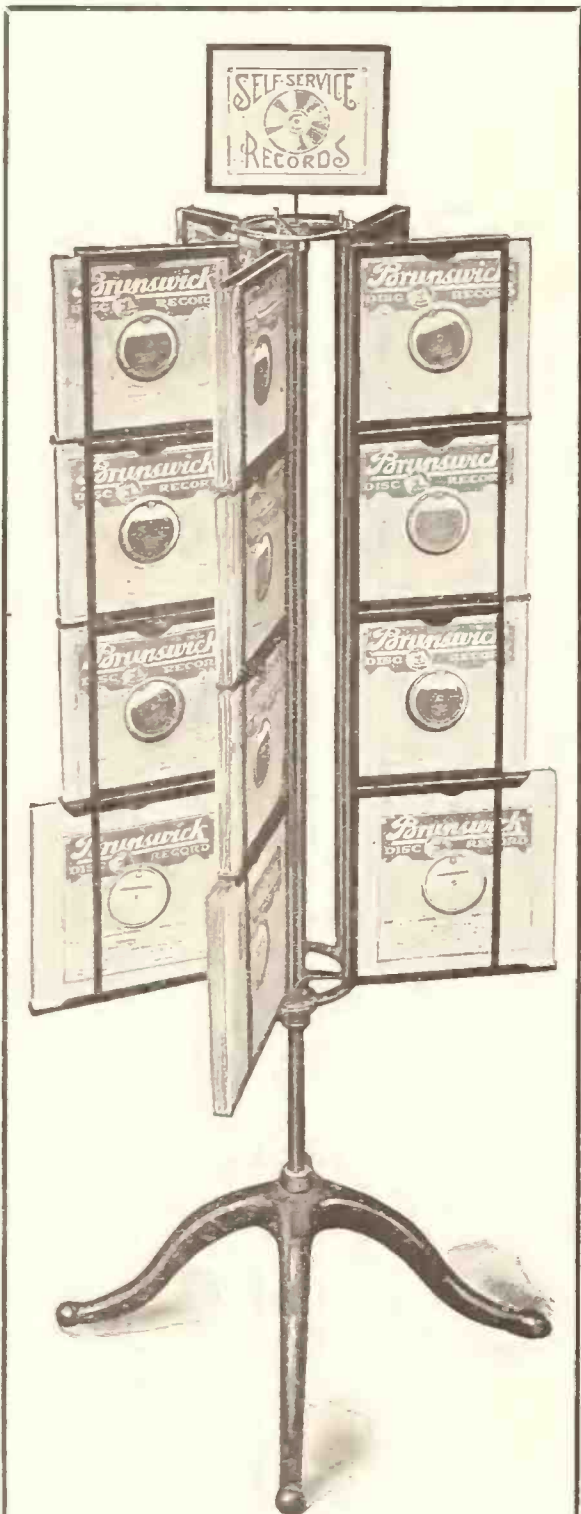

NO. 578. UNIVERSAL SELF-SERVICE RECORD DISPLAYOR made to hold 5 swinging leaves, each leaf accommodating three 10" pockets and one 12" pocket. Each pocket holds four records. Total number of records shown is 40 records and holding a reserve stock of 160 records. Height 6 ft. Width 30 in. Weight 125 lbs. Constructed of steel throughout, with heavy cast-iron base and finished in two coats of ebony enamel.

Complete.....\$35.00

Write for complete catalogue

**UNIVERSAL FIXTURE CORP.**  
133 West 23rd St. New York

## We Have It!

A HIGH-CLASS TABLE MACHINE AT A PRICE THAT SELLS



Mahogany, 16x16x10, Double Spring, Universal T. A. Back Casting and Metal Horn  
Sample Price to Dealers Now—\$12.50  
Send for Sample To-day  
Phonographs and Accessories, Repair Parts for All Makes.  
Best Steel Needles of American Manufacture at 30c. per M.

**FULTON TALKING MACHINE CO.**  
253-255 Third Ave., New York City  
Between 20th and 21st Streets



# Sprague Radio Receiving Sets

are the product of many years of radio development in a laboratory continuously and exclusively engaged in Radio research

## Simple Operation—Selectivity—Perfect Reproduction and Amplification

The market has been flooded with amateur radio equipment of uncertain quality and imperfect construction wholly lacking in those points of superiority found in professional equipment.

All Sprague radio equipment was developed and is manufactured in a plant that has designed and built many successful transmitting stations for marine and land service and has been one of the principal suppliers of the Government and the commercial companies. Sprague home sets are all made with the same care and precision used in the construction of this fine professional equipment.

### First, you sell this self-contained, complete unit *Receiver*

Professional in construction, but so simple in design that anyone, even a child, can operate it easily. Our detector control makes possible the clear reception of weak distant signals.

List \$88.50—"A" Battery and Head Set extra



## Sprague Radio Console

This Queen Anne Period Console is an ideal home instrument of remarkable delicacy and range. It encloses a complete wireless receiving equipment of the same high quality and construction identical with all Sprague Radio.



CLOSED



OPEN

List  
\$450.00

### The second unit, "A" Battery Case

This is connected at the side of the first unit and forms a neat compact housing for the "A" Battery. The case is protected from battery acid by a lining of asphaltum. Will hold a large size six-volt storage battery.

List \$11.50



### Then add the *Three-Stage Amplifier*

This connects with the top of the Receiver, the first unit. The unique scientific arrangement of the component parts of this Sprague Radio amplifier effectively avoids distortion.

List \$130.00



### Complete the Assembly with *Spragaphone Loud Speaker*

The fourth unit connects with the side of the amplifier and over the Battery Case. It is especially designed for home use, is extremely sensitive, but is capable of producing a greater volume of sound than is required to fill even a very large room.

List \$95.00

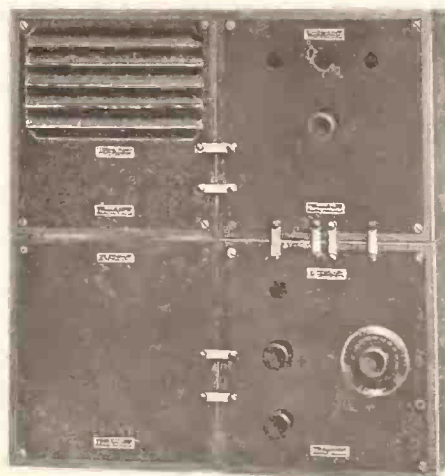

"Long Range"  
Four Units Assembled Complete  
\$325.00

Except in large cities, agency is limited to one dealer in a town

# Sprague Radio corporation

342 Madison Ave., New York, N. Y.

TELEPHONE: 8373 VANDERBILT

Extreme discounts to Reputable Dealers. Write or wire us at once



C. R. JOHNSTONE  
VICE-PRES., GEN. MGR.

# THE BELL RECORDING CORP.,

Associated With National Metals Depositing Corporation

9 East 47th Street, New York City

**B**EST RECORDING  
**E**XPERIENCED SPECIALISTS  
**L**OUD AND CLEAR  
**L**AST WORD IN QUALITY

We Specialize in Private Recording  
and  
General Recording for the Phonograph Trade

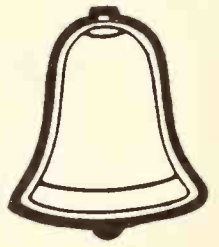

### W. HAUSSLER'S STRONG ARGUMENTS

General Manager of C. Bruno & Son, Inc., Makes Forceful Address Before Meeting of Metropolitan Victor Dealers' Association—Value of Window Displays for Dealers

General business conditions as they affect the Victor retailer formed the subject of an intensely interesting address given by William J.



W. J. Haussler

Haussler, vice-president and general manager of C. Bruno & Son, Inc., Victor wholesalers, of New York City, at a recent meeting of the Metropolitan Victor Dealers' Association. Mr. Haussler touched on the present-day situation and stressed the big future possibilities in Victor business. Describing the Victor Co. as the greatest and ablest organization of its kind in the

world, he stated that to be associated with such an institution was an asset and just cause for pride on the dealers' part and urged that Victor retailers put the interest of the Victor business as a whole far above any personal or passing consideration of their own. Mr. Haussler pointed to the advertising of C. Bruno & Son, Inc., in the talking machine trade papers and told how the merchandising suggestions given therein were given solely for the purpose of helping the Victor retailer to increase his business. In his talk Mr. Haussler demonstrated a complete mastery of his subject and presented it in a spirited manner. Many dealers at its close described it as one of the most helpful addresses that they had ever listened to.

With the co-operation of a number of music publishers, C. Bruno & Son, Inc., Victor wholesaler, New York City, are preparing a series of window displays for the Victor retailer featuring from three to seven of the popular song hits appearing on Victor records. The first display was sent out on July 10, to be followed by others at short intervals.

### S. L. COOK IN NEW HOME

INDIAN HARBOR, IND., July 8.—S. L. Cook, successful Columbia dealer here, has moved his place of business to larger quarters in the same community. Attractive interior decorating, coupled with reliable service and merchandise, has made this Grafonola shop one of the foremost music shops in this locality.

### NEW LINES FOR BRISTOL & BARBER

Bristol & Barber, New York City, have taken on the Outing portable, made by the Outing T. M. Co., and the Clay-o-la line of talking machines, manufactured by Geo. Clay Cox, in addition to the other lines of machines and accessories that they distribute.

### EDISON PITTSBURGH DEALERS MEET

Quarterly Meeting of Dealers in Pittsburgh Zone Hears Interesting Address by F. C. Beatty and a Number of Other Trade Members

PITTSBURGH, PA., July 6.—An important meeting of the Edison Disc Dealers' Association, Pittsburgh Zone, was held here recently at the Fort Pitt Hotel. This was one of the regular quarterly meetings held by this body. The feature of the occasion was an address by F. C. Beatty, who represented Thomas A. Edison, Inc., and whose talk was devoted to explaining the important new plans which are now on deck with the Edison trade. Other talks of an illuminating sort were made by representatives of the Buehn Phonograph Co., local Edison jobbers, and members of the Dealers' Association. The entire affair was a complete success and announcements made by Mr. Beatty provoked great enthusiasm from the Edison retail merchants attending.

### NEW BRUNSWICK SHOP IN SALEM

Odell Bros. Take on Brunswick Line for New Store—Unico Installation Throughout

SALEM, Mass., July 10.—Kraft, Bates & Spencer, Brunswick distributors for New England, have concluded arrangements for a Brunswick account in Salem. This will be known as The Brunswick Shop and is under the ownership of Francis B. and Charles Odell. The Odell brothers are planning to go after business in an energetic manner and are providing efficient store equipment through arrangements they have made with the Unit Construction Co., of Philadelphia, for an installation of Unico equipment in their store at 64 Washington street. The formal opening will be on July 21. Arrangements have been made for the Carl Fenton Orchestra to be there on the opening day.

## NATIONAL METALS DEPOSITING CORPORATION

FACTORY  
34 East Sidney Ave., Mt. Vernon, N.Y.  
Telephone: Oakwood 8845

MOUNT VERNON — NEW YORK  
MANUFACTURERS OF

LABORATORY  
415 Fourth Ave., New York, N.Y.  
Tel. Madison Square 6635



WE DEPOSIT THE  
FINEST COPPER  
IN THE WORLD

FOR YOUR CONVENIENCE  
DELIVER RECORDED WAX  
TO OUR LABORATORY

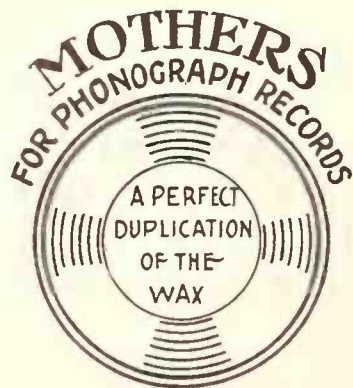

OUR  
IMPROVEMENT  
ALL STAMPERS  
HAVE  
HIGHLY POLISHED  
MACHINED BACKS

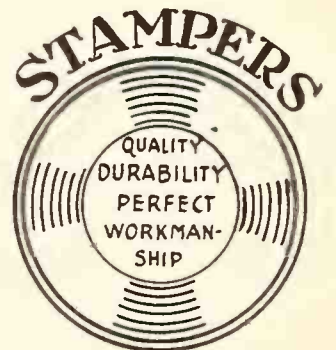



**AMONG THE LEADING FIFTY**

Four Talking Machine Manufacturers in List of Leading Advertisers—Victor Talking Machine Co. Is the Second on the Entire List

In the July 6 issue of *Printers' Ink* there appears an interesting table showing the amount of money spent by fifty advertisers in thirty-six publications during 1921. These data were compiled by the Curtis Publishing Co., of Philadelphia, and the compilation does not include the total advertising investment of the concerns in question. The great majority of these companies are heavy users of newspapers, farm papers, outdoor advertising, window displays, etc., and the figures, therefore, constitute only a certain proportion of their expenditure.

It is interesting to note that four prominent talking machine companies are included in this list of fifty leading advertisers. The Victor Talking Machine Co. is second on the entire list, with an expenditure of \$1,239,693 in the thirty-six publications comprising the estimate. The leader of the list is the Joseph Campbell Co., manufacturer of Campbell soups.

The Columbia Graphophone Co. is seventeenth on the list with an expenditure of \$497,411, while Thos. A. Edison, Inc., spent \$326,471 and the Brunswick-Balke-Collender Co. spent \$302,975. These figures are especially interesting when it is realized that talking machine manufacturers are the only musical instrument concerns included in this list of fifty leading advertisers.

**NEW PHYSICAL EXERCISE RECORDS**

Victor Talking Machine Co. Puts on Market Sets of Three Special Records and Charts Prepared by Prof. Charles H. Collins

The Victor Talking Machine Co. has just placed on the market the new Victor physical exercise records which are now being delivered to wholesalers and dealers. The outfit consists of three double-face records, 10-inch size, covering twelve distinct exercises with appropriate music prepared on a plan and under the supervision of Prof. Charles H. Collins, of the Collins Health Institute, of Philadelphia. The records, with instructions for use, are packed in a durable case which, when opened, shows complete charts and positions for each exercise. The set of three records and container is listed at \$3.

**O. H. WILLIAMS WITH CHAPMAN**

O. H. Williams, well known in talking machine circles in Greater New York and who was formerly actively engaged as general manager of the Halsted Williams Co., Brooklyn, is now located in Rochester, N. Y., as representative for E. J. Chapman, Victor distributor for New York State. Mr. Williams has had wide experience in the Victor field, which covers a period of many years. He was a traveling representative of the Victor Talking Machine Co. for a long time and also was connected with two well-known Victor wholesalers and is well qualified to promote dealer interests in his present connection. Since joining the Chapman organization, three months ago, he has been able to establish many new and desirable accounts and no doubt will prove himself a valuable man for this wholesaler in every respect.

**VICTOR CO. PLANS EXTENSION**

CAMDEN, N. J., July 8.—Approval was given by the Street Committee of the City Council here to a request of the Victor Talking Machine Co. that the city vacate Ambler street from Cooper to Penn streets.

The Victor Co. agreed to pay the nominal sum of \$500 in return for the privilege granted by the city. The company is planning to erect a building in the space to be vacated.

The fellow who is sure that he knows it all usually lacks the brainpower to know much of anything.

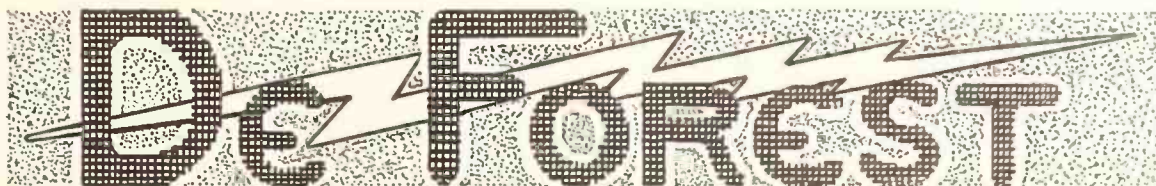

**Radiophones For Dependability**

Reg. U. S. Pat. Off.

To the list of distinguished houses recently announced as jobbers, De Forest Radio Telephone & Telegraph Company has added

**ALBANY RADIO CORP.**

ALBANY, N. Y.

The size, prestige and reputation of the music houses that endorse De Forest products should convince the most skeptical dealer that the De Forest Line is the one to which he should tie up.

Possessing an old-established radio business, De Forest is not cultivating the talking machine trade for the sake of immediate returns.

We would not, if we could, load up phonograph dealers' shelves, nor is there any stock in this company for sale.

Consequently, in conferring patronage upon us, which we will accommodate to the best of our increasing capacity, the talking machine dealer may rest assured that he will never be left high and dry with "out-of-date" merchandise.

Nor will we use his "ownership of stock" in our company as compulsion on him to over-buy.

The De Forest Line includes MR-6 all wavelength range Receiver, the Everyman Receiver, the Radio-home Receiver, the DT-800 Amplifier, and the Radiobest Receiver

For those who build their own sets, De Forest also manufactures Rheostats, Tube Sockets, Coil Mountings, Honeycomb Coils, Grid Leaks, Condensers, Transformers, Crystal Detectors and Switches.



"I'm Glad We Own a Radio Phone"

**General Offices:**  
Franklin Street and Central Avenue  
Jersey City, N. J.

**Factories:**  
Jersey City, N. J.  
Jackson, Mich.







On-ly a ba--by That's why ev-ry-bod-y "ba-bies" you,

# You're Only A Baby

A Fine Swinging Fox Trot Melody

HEAR IT NOW!

"You can't go wrong  
With any FEIST' song"

### SCORE AT CHICAGO RADIO SHOW

Raymond Engineering Corp. Exhibits Its Non-regenerative Three-tube Receiving Set, Which Wins High Praise at Exhibition

The Raymond Engineering Corp., New York, manufacturer of everything in radio, reports that since the company entered this field some eight months ago its plant has been kept extremely busy and that present indications point to a very busy Fall in the radio field. The company specializes in the manufacture of complete radio units for manufacturers and distributors, but is now planning to enlarge its field of radio activities by manufacturing a receiving set that will be known as the Raymond radio receiving unit. This will be placed on the market as a separate unit, and also will be furnished in a well-designed cabinet of the console type, which it is expected will meet with considerable favor in the talking machine field.

C. M. Hunt, sales manager of the company, working in conjunction with A. Schwartz, manager of the Chicago office, spent a profitable two weeks exhibiting at the Chicago radio show held in that city the latter part of June. In Booth 71 was featured the company's non-regenerative three-tube receiving set, which attracted considerable attention. This set was attached to a specially designed loud speaker and functioned without the use of an extra battery. Mr. Hunt stated that the results obtained from this non-regenerative set and loud speaker were most satisfactory and it was commented on favorably by all who saw it. Several technical schools who were exhibiting and giving instructions to radio amateurs were so impressed with the merits of this set that parts for constructing a complete unit were loaned to these schools by Mr. Hunt and were used for instructing and demonstrating radio receiving during the time of the show.

The success attained at the radio show was very gratifying to the officials of the company,

and influenced them to manufacture a set of the same type to introduce to the talking machine trade, which will be placed on the market within a very short time.

### SONORA PORTABLE PRODUCES SALES

MILWAUKEE, Wis., July 8.—W. E. Pugh, city salesman for the Yahr & Lange Drug Co., Milwaukee, Sonora jobbers, is a keen admirer of



An Enterprising Sonora Man

the Sonora portable and always carries one with him on his sales trips. Mr. Pugh maintains that the combination of an automobile with a Sonora portable cannot be excelled for producing speed records in Sonora sales.

The White Music Co., of Berkeley, Cal., has added radio outfits and supplies to its general stock of musical instruments.

### NEW DE FOREST RADIO AGENTS

Several Prominent Talking Machine Houses Now Handling That Line

The DeForest Radio Telephone & Telegraph Co. announces an addition to the list of distinguished music houses who have been appointed jobbers of DeForest radiophones. It has included the Schmelzer Co., of Kansas City, Mo., and the Albany Radio Corp., Albany, N. Y. Other music houses included are: Lyon & Healy, Chicago; Owen & Beers, New York City; Triangle Radio Supply Co., New York City; Silverstone Music Co., St. Louis, Mo.; Rochester Phonograph Co., Rochester, N. Y.

### PENNSYLVANIA HOUSE REORGANIZED

The Pioneer Music House, Inc., Has Elected a Strong Board of Officers, With J. M. Stewart as President—Capital Stock Now \$150,000

INDIANA, Pa., July 10.—The Pioneer Music House, Inc., has succeeded the old firm of S. Ren Pollock, Inc., which has been operating in this city since 1891, having been founded by S. M. Work. The officers of the new company are: J. M. Stewart, president; C. F. Gaylord, vice-president, and H. C. Trader, treasurer. The company is incorporated under the laws of Pennsylvania with capital stock of \$150,000.

The new company has started work on a two-story addition to its present building and also plans to entirely remodel the interior of the store, making it one of the most attractive establishments in this section of the State.

The Pioneer Music House features the Brambach, Packard and other makes of pianos and player-pianos, and has a large talking machine department, in which is handled the Victor, Edison and Brunswick lines of machines and records. Musical merchandise and sheet music are also carried.

RETAIL PRICE \$15.00  
FULLY GUARANTEED



# Qualitiphone

A SMALL PHONOGRAPH THAT WILL LAST

A Success With Dealers Everywhere—It has proven its worth

Neat, compact and sturdy, with all the features of the high priced instrument. In perfect balance—tested by experts to the thousandth part of an inch.

Equipped with automatic speed regulator—start and stop device, genuine mica sound box. A real motor—silent and durable.

Attractive Proposition for Jobbers — Write for territories

QUALITIEPHONE SALES CORP. 17 EAST 42nd STREET  
NEW YORK CITY



**MAY BE THE OFFICIAL GOLF SONG**

**"The Nineteenth Hole," Published by Leo Feist, Has Made a Tremendous Hit**

Leo Feist, Inc., announces the release of a new song called "The Nineteenth Hole." This number, as its title indicates, is a golf song and has already been heard in some of the country clubs in and about New York, where it has been received with much enthusiasm. There is every indication that it will be adopted by golfers as their official song. It lends itself readily to the "gang" spirit and inasmuch as its lyric is typical golf language it wins immediate approval.

Edgar F. Bitner, general manager of Leo Feist, Inc., speaking of the release of "The Nineteenth Hole," said: "We have looked for some time for a song that would describe the life on the links and in the club house. Many lyrics were presented to us for examination, but none seemed to fit the situation. We believe this number, which is full of comical golf language, fills the bill."

**BOOKED SUBSTANTIAL ORDERS**

**Player-Tone T. M. Co. Secures Substantial Business at Furniture Show—I. Goldsmith Optimistic Regarding Future**

PITTSBURGH, PA., July 8.—I. Goldsmith, president of the Player-Tone Talking Machine Co., this city, returned recently from the Grand Rapids furniture market where the company maintained an attractive exhibit. The company has arranged to manufacture three new upright models at popular prices and, according to the business booked by Mr. Goldsmith at Grand Rapids, the outlook for the talking machine business this Fall is going to be far better than heretofore.

Mr. Goldsmith states that there was a considerable amount of buying done in the West owing to excellent crop conditions and the dealers who visited the furniture show were confident that business in general would be healthy and active during the coming Fall. During the past few months the Player-Tone Talking Machine Co. has received substantial orders from its dealers and Mr. Goldsmith is making arrangements whereby the new models will be ready for delivery next month.

**CARL KNITTEL VISITS NEW YORK**

Carl E. Knittel, sales manager of the Wolf Mfg. Industries, Quincy, Ill., was a recent visitor to New York. Mr. Knittel secured some good-sized orders for the Wolf products and found the trade particularly interested in the new console cabinet that the company has just introduced which is adaptable for radio installation. He states that business conditions generally show a decided improvement and, judging from the orders received, the talking machine trade will enjoy a healthy Fall business.

**SIXTH WEEK OF GOLDMAN CONCERTS**

The Goldman Band, under the direction of Edwin Franko Goldman, is completing its sixth week at Columbia University, with programs that will be a delight to all music lovers. As the Summer session of the University is now in full swing, with its 13,000 new students, the audiences will now be larger than ever. On Friday night, July 21, the first half of the program will be devoted to the works of Tschaiikowsky. Mr. Goldman's two new compositions, "The Chimes of Liberty" and "In the Springtime," have become so popular that they are demanded almost nightly. Free season tickets are still available and may be had upon written request to "Summert Concerts," Columbia University, New York City, the only requirement being that a self-addressed, stamped envelope be enclosed with request.

The Inland Music Co., of Spokane, Wash., recently went out of business.

**VICTOR TRAVELERS TO MEET**

**Annual Convention of Traveling Sales Department to Be Held in Camden Next Week**

The annual convention of the members of the traveling sales department of the Victor Talking Machine Co. will be held at the factory in Camden next week, the first conference being held on Monday, July 17. An extensive and intensive program has been mapped out for the convention. Members of the traveling staff will be housed at Green Hill Farm during the week, although the business sessions will be held at factory headquarters.

**NEW SONORA WINDOW STRIPS**

The advertising department of the Sonora Phonograph Co. has just forwarded to all Sonora dealers thirteen window strips, consisting of twelve paper strips and one of muslin. The

muslin strip, being large and durable, may either be fastened to the dealer's awning or tacked on to the wood base of the window. The other twelve strips are of various sizes, each different in design and showing the latest Sonora models in handsomely lithographed color effects.

**VOCALION RECORDS OF NEW PIANO**

**Successful Recordings Made of Tones of Moor Duplex Octave Coupler Piano**

The Aeolian Co. has announced Vocalion records of the music of the new Duplex octave coupler piano, the invention of Emmanuel Moor, and which has been subjected to international comment during the past year or two. The records have been made by Winifred Christie and Max Pirani, there being four twelve-inch double-face records in the group. The new piano, it is declared, makes possible effects absolutely unattainable on the ordinary piano.

**Tune In**

The Music Master Radio Amplifier greatly magnifies sound volume, with reproduction free from any harsh metallic screeching. The horn is made from richly grained mahogany and with the nicely finished goose-neck and base provides a handsome yet practical radio necessity. Made in two sizes—21-inch for concerts and out of doors, \$45.00. 14-inch for general use in home, \$35.00.

Geraco Variometer and Variocoupler assemblies are a long step ahead in the development of accurate tuning instruments, being the perfected result of exhaustive tests by competent experts. Note the detail of design (see variometer illustrated to left) the composition posts and absence of unnecessary metal parts. Price \$6.00 each.

Geraco moulded dials will improve the appearance of any set. A smooth black surface that will not discolor or chip. Neatly finished and accurately calibrated. 3-inch size, 50c

Geraco moulded parts are carefully manufactured from a durable and tested industrial material. This dielectric substance has proved qualities which assure our guarantee of minimum power loss. This fact is borne out by the opinion of the Bureau of Standards of the United States. See circular No. 74, Radio Instruments and Measurements.

Items in the Geraco line now obtainable:

Variometers complete	Variocoupler complete
Variometer rotors	Variocoupler tubes
Variometer Post Assemblies	Variocoupler balls
Variometer stators	Vacuum tube sockets
Dials	Crystal detector bases
Knobs	Aerial insulators
	Music Master Radio Amplifiers

Manufacturers and Dealers—Write at once for complete schedule

**General Radio Corporation**  
Manufacturers and Distributors of  
High Grade Radio Apparatus  
624-628 Market St.  
PHILADELPHIA

**GERACO**  
PROVEN RADIO PRODUCTS

The two units of the Geraco line illustrated above represent the most masterly development in the electro-mechanical field our products dominate.



# *The Last Word in Electric Phonograph Motors*

Make this *your*  
leading line for  
the coming  
s e a s o n

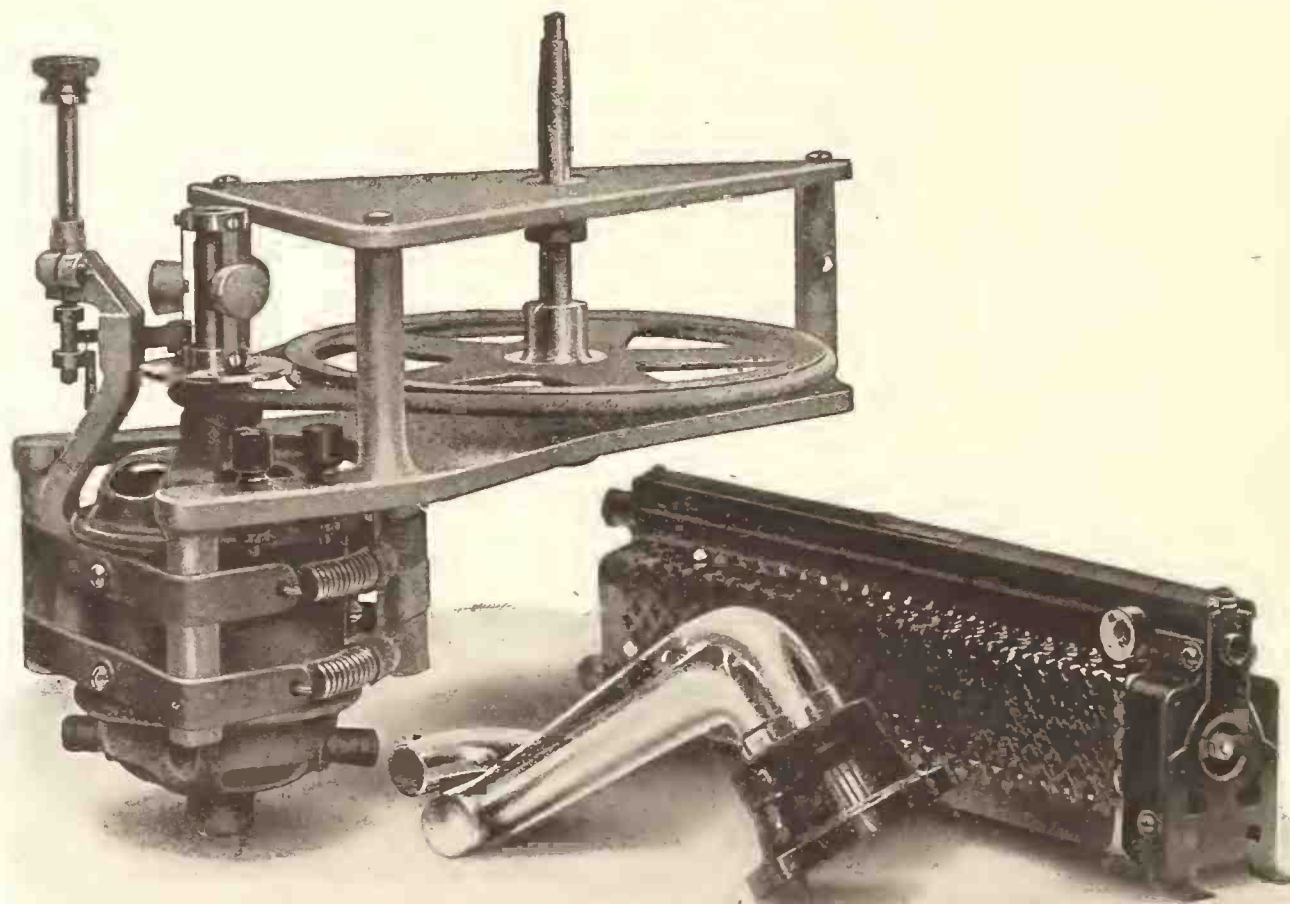

## **The Electromophone**

**Absolutely Silent**

Adjustable to any voltage. Tone arm equipped with electrical stopping device, which operates in conjunction with the Electromophone—Record stops automatically on last note—Never fails!!

---

*The Sole Selling Rights of This Unique Mechanism Are in the Hands of*

**THE STERNO MANUFACTURING CO.**

19 CITY ROAD

LONDON, E. C., ENGLAND



Prince's Dance Orchestra has scored another knock-out for the waltzers in "Gypsy Love Song," introducing the "Good Morning Chorus" and "She Said 'I Was So Lonely'," from *The Fortune Teller*. For an encore they play, on the other side, Victor Herbert Waltz Gems. Here is waltz rhythm de luxe. A-3636.

Columbia Graphophone Co.  
NEW YORK



# PORTLAND, ORE.

*E. B. Hyatt Heads Oregon Music Trade Association—Rose Festival Produces Many Artistic Windows—Dealers Co-operate—The News*

PORTLAND, ORE., July 8.—E. B. Hyatt, of the Hyatt Talking Machine Co., was unanimously elected president of the Oregon Music Trades Association at the annual meeting held recently. Other officers elected for the coming year were W. A. McDougall, of the McDougall-Conn Music Co., first vice-president; M. Davis, district manager of the Brunswick Phonograph Division, second vice-president; J. J. Collins, vice-president of the Reed, French Piano Co., secretary, and Frank M. Case, manager of the Wiley B. Allen Co., treasurer.

Portland's annual Rose Festival was again a thing of "joy and beauty" and was successful from both an artistic and business standpoint. It brought many visitors to the City of Roses and, although not much business was done by any of the music houses during the days of the festivities, sales took a big jump immediately following the celebration.

All dealers dressed up their stores and windows to suit the occasion. J. N. Dundore, manager of Sherman, Clay & Co., was "Prime Minister of Rosaria" and escorted "Queen Harriet" wherever she went.

The floral parade was most beautiful, and out of the many hundreds of floats the one entered by the Victor dealers of Portland stood out as one of the most attractive and unique floats of the entire parade. The judges must have thought so, too, as the float was awarded the grand prize of its division.

Mary Elizabeth Godwin, educational director of the Victrola department of Seiberling & Lucas Music Co., was the originator of the plan and it was due to her untiring efforts that the float was perfect in every detail. A Victrola made of pink roses, large enough to enclose a six-piece orchestra, was built on the float, and music

was dispensed all along the route. Nine beautiful little girls were on the float and danced aesthetic and folk dances whenever the parade halted to give the drill. Victor dogs were much in evidence.

The following Victor dealers contributed to the affair: Sherman, Clay & Co., wholesale and retail; Hyatt Talking Machine Co.; Bush & Lane



E. B. Hyatt, President Oregon Association Piano Co.; G. F. Johnson; Wiley B. Allen Co.; Powers Furniture store; Reed, French & Co.; McCormick Music Co.; Seiberling & Lucas; Meier & Frank, and Charles D. Ray.

A Sonora phonograph completely dismantled, showing the complete construction of motor and sound box, made an attractive window display at the Lipman, Wolfe & Co. store and many people interested in the "inner works" of a phonograph stopped to examine it. Men especially stopped to see first what "made the wheels go round." Roy Feldenheimer, manager of the phonograph department, reports increased Sonora business since the window demonstration and says: "I always find it pays to advertise your goods, no matter how well known they are, and to keep them before the eyes of the public."

Mary Elizabeth Godwin, educational director of the Victrola department of Seiberling & Lucas Music Co., is being featured on the Willard Hawley, Jr., Broadcasting programs and several times a week she entertains with a "children's hour" when selected records for the kiddies are broadcasted.

J. Walter Johnson, window decorator of Powers Furniture Co., won a handsome silver cup as a grand prize for the best decorated window displays during the Elks' Golden Jubilee and

another large silver cup awarded for the best music display window. A large Victor dog and a handsome elk's head were the main figures in the window with Victrolas, Victor records and purple and white ribbons artistically arranged.

All of Portland has gone or is planning to go on a camping or beach trip this season is what the dealers in the small camp outfits believe and reports from all sides are to the effect that the portable machines are going like "hot cakes."

C. W. Collins, manager of the Cable Piano Co., of St. Paul and Minneapolis, was a recent Portland visitor. He was on his way home from the Rotary Club convention in Los Angeles. He paid his respects to Frank M. Case, manager of the Wiley B. Allen Co.

C. N. Sundquist, floor manager of the Victrola department of Sherman, Clay & Co., took unto himself a June bride (Olivette Mills) and is receiving the congratulations of his friends since his return from Vancouver, B. C., where a two weeks' honeymoon was spent.

O. N. Gore has been added to the sales force of the Victrola department of the Sherman, Clay & Co.'s store.

Kathryn Campbell has been placed in charge of the record and roll department of the Portland Piano Co. of Lipman, Wolfe & Co.

A new agency for the Valuphone and Mandel phonographs has been established in Portland at 467 Washington street, with Frank A. Bergman, manager in charge. Mr. Bergman handles the Gennett records and has the honor of being the exclusive dealer of this popular record on Washington street. Miss Belle Montpas is in partnership with Mr. Bergman and it is announced that the business partnership is soon to be a life partnership as well.

## UNEMPLOYMENT DECREASING

Figures gathered by the Merchants' Association of New York for the use of the Committee on Unemployment of New York City show that industry is reviving. A canvass just completed indicates a decrease in the number of workers now out of work. This means greater activity in the retail domain.

There is no time like the present for performing disagreeable tasks. Get them over with at once and set your mind at rest.

## OSLAND, Inc.

122 Fifth Avenue, New York City

*Alpha Reproducer*

Pivot stylus with spring tension

Radio products

Variocouplers

Variometers

Variable condensers

MANUFACTURED TO SPECIFICATIONS

THE MELODIOUS AND TUNEFUL  
A "HIT" EVERYWHERE  
STAGE AND DANCE  
**THREE LITTLE WORDS**  
FOX-TROT  
SHEET RECORDS ROLLS  
JOE MITTENTHAL · INC · NEW YORK



### RADIO AND THE LOOP AERIAL

H. F. Thornell Explains the Adaptability of the Loop Aerial for Use in Connection With the Receiving Apparatus of the Radio in the Home

Harrison F. Thornell, who is well known throughout the country, particularly in the music industries, having traveled extensively in the interest of several musical devices, recently entered the radio field, forming a company under the firm name Eagle Radio Co., Newark, N. J. Mr. Thornell is the producer of a series of devices, some of which are for the purpose of eliminating obstacles and simplifying radio receiving apparatus and its use in larger cities, particularly apartment houses.

In an interview with a representative of The World Mr. Thornell said:

"Due to the enormous demand in the cities for radio receiving apparatus, the problem of aeri-als has become a big and a serious one, but, like other difficulties connected with radio, it couldn't be a difficulty long, and now is satisfactorily

overcome by means of an indoor loop aerial.

"The great majority of city dwellers live in apartments, and comparatively few of these people have been able to install radio receiving sets because of the question of aeri-als. Only a limited number of aeri-als can be erected on one roof, and none can be erected if the owner of the building objects, which the majority do, either because they think that there is danger from lightning or because they do not want the outside of the building cluttered up with wires. Then, too, in some cases, where an aerial could be erected, the question of lightning ground and the location of the rooms make this type of aerial impractical. This has resulted in the growth of the industry to date being largely limited to the country and suburban sections of the cities, with the vast majority of the city dwellers without any radio to date.

"The rapid growth of the radio industry has been so sudden that until very recently this matter has not been seriously studied by radio engineers. The consensus of opinion now is that the solution of the problem lies in the loop aerial

and with the advent of a good and practical loop aerial on the market the number of radio enthusiasts will jump ahead again by leaps and bounds.

"The loop aerial, to be practical and at all efficient, has required considerable experimental work and careful study. Special kinds of wire and careful designing to reduce the losses to an absolute minimum have resulted in the loop aerial now being practical in its operation and construction. A point overlooked by many people is that the loop aerial must be of such a size that it will not be in the way and take up too much space in an ordinary room, such as is found in a city apartment house.

"In a great many cases, other than those mentioned above, the loop aerial is more practical and serviceable than the conventional out-of-door aerial. Due to its marked directional receiving qualities, it is a big help in reducing, and eliminating, the interference from nearby transmitting stations, and also static electrical interference is greatly reduced, a big advantage in the Summertime. The loop aerial can also be used in any place desired without the necessary delay or bother in running wires, climbing trees, erecting poles, etc. With the coming perfection of radio-frequency amplification the use of the loop aerial will come into almost universal use for receiving, and it is only a question of a comparatively short time when the aerial will only be used by the ultra-energetic person who delights in climbing around high places and who doesn't care about the unsightliness of an outside aerial.

"There is not the slightest doubt that radio is here to stay, and with it the loop aerial, because of its portability, directional qualities, reduction of static and other undesired interference and general all-around usefulness in the radio field."

## Study the **SILENT Motor**

Its Advantages for Your Line of Talking  
Machines Are Self-Evident

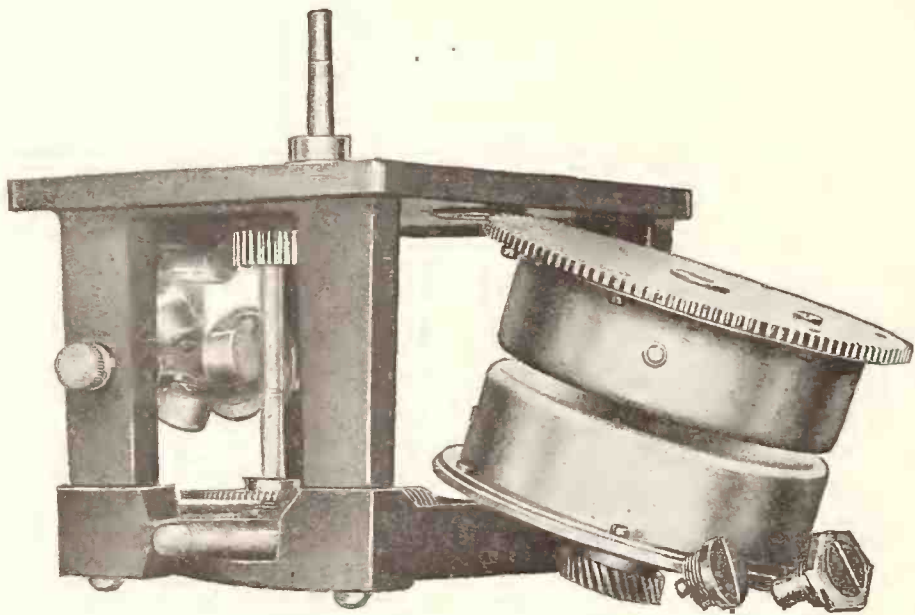

The Silent Motor With Spring Barrels Demounted. Note the Sturdy and Simple Construction.

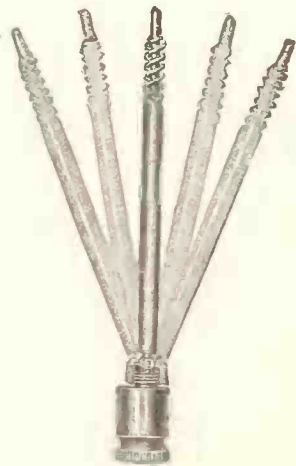

An Exclusive  
**SILENT MOTOR** Feature.

Self-aligning governor shaft,  
mounted on universal ball-and-  
socket bearing. Eliminates gov-  
ernor trouble forever.

Send for Sample and Prices

### THE SILENT MOTOR CORPORATION

CHARLES A. O'MALLEY, *President*

321-323-325 Dean Street,

BROOKLYN, N. Y.

### MELODY SHOP OPENS IN SEATTLE

Victor and Columbia Machines and Records  
Featured in Fine Department

SEATTLE, WASH., July 7.—The most recent addition to the music stores of this city is an attractive establishment opened at 1402 Second avenue and known as the Melody Shop. The store features the Victor and Columbia lines of talking machines and records. During the formal opening, which was well attended, each purchaser was presented with a popular dance record. Purchasers of sheet music were presented with an autographed copy of the latest composition from the pen of Harold Weeks.

### BUSINESS PROSPERITY HERE

Survey by Department of Commerce of Various  
Industries Indicates Revival

WASHINGTON, D. C., July 7.—Business is booming again, the Department of Commerce reports.

Statistics for June, just completed, show the tide of prosperity is rising steadily. Out of forty-two industries tabulated thirty-eight showed increases in production over the previous month.

The agricultural situation is considered particularly good. Building is having the biggest boom it has ever known and is carrying with it many allied industries.

The department issued a warning against business men practising "excesses" during the period of prosperity, because they cause depression.

The coal and railroad strikes constitute the only threat to better business, the Department states.

The Brunswick Music Shop, 49 Tenth street, Allentown, Pa., is the name of the latest addition to the music stores in that city. The Brunswick line is handled exclusively.

A few years ago there was a small dealer in a medium-sized town who believed in the power of advertising and each year as his business grew he made his advertising appropriation larger. To-day he has a very large business. The reason is obvious.



*The Aristocrat of All Radio Receiving Sets*

# The Radio Phonolier

*Awarded first prize for most meritorious Radio Novelty  
exhibited at New York Radio Show, May, 1922*



In reality the Radio Phonolier comprises the most perfect and compact 3-step receiver including our new "ALL WAVE" coupler (with guaranteed wave length of 150 to 3,000 meters) and loud speaker, all artfully yet artistically embodied in the form of a beautiful table lamp, built entirely of copper. Easily and accurately tuned and can be set for any desired wave length—then all that is required is to connect the lead from the instrument to battery box—just child's play. Functions equally well with indoor or outdoor aerial. The indoor aerial is incorporated in the outfit, but if the use of outdoor aerial is desired a dial on panel governs the change from one to the other. The base (which conceals the loud speaker) is finished in bronze, silver or gold.

*In appearance and efficiency it  
surpasses any phonograph*

**Because—The first cost is the last!**

**No changing of records!**

**No additional records to buy!**

**Monotonous repetition is replaced by endless  
variety of entertainment**

For the Radio Phonolier is a permanent, yet ever changing record bringing in the wonderful vocal and musical selections now being broadcasted all over the country, CLEAR, SWEET, and LOUD, WITHOUT DISTORTION.

*Easy to tune  
Mistake-proof  
Nothing to get out of order  
No technical knowledge required*

The Radio Phonolier is a musical instrument to be proud of.

Now is the time to book up out of the forthcoming production at a cost of \$300 up—less attractive discounts.

**Capitol Phonolier  
Corporation**

54-60 Lafayette Street

New York, N. Y.





# The Merchandising Possibilities of Radio in the Talking Machine Field :: :: By Raymond F. Yates

Radio Editor, The Evening Mail

One of the most interesting talks on radio that local talking machine dealers have been privileged to listen to was that delivered at a recent meeting of The Talking Machine Men, Inc., by Raymond Francis Yates, radio editor of The Evening Mail, in New York, who offered some practical thoughts regarding the merchandising of radio and the lines on which it might be expected to develop.

After commenting upon the development of the automobile, motion picture and the talking machine through various stages, from the time when they were considered merely as fads to a point where they became recognized commercial successes, Mr. Yates emphasized the close connection between radio and the talking machine and enlarged upon the field for a combination instrument including, in one cabinet, a talking machine and a radio receiving set.

The speaker made the point that the success of the talking machine business and the quantity sale of higher priced machines came when means were provided for selling better class instruments on instalments. In this connection he said:

"The radio industry must parallel the phonograph industry in this respect if it is to enjoy the same prosperity. To-day radio instruments cannot be bought on the time payment plan simply because the manufacturers do not have to sell them that way. They have found enough purchasers who are willing to pay cash. The great majority of American homes will not have the more expensive radio instruments until the manufacturers co-operate with the dealers in arranging more convenient payments.

#### Should Be Sold by Phonograph Dealers

"To-day radio instruments are being sold in various kinds of establishments. We see them in drug stores, hardware stores, electrical shops, dry goods stores, phonograph shops and recently I saw a display of instruments in the show windows of a hat store. The electrical industry claims that radio belongs in the electrical shops, but I am not inclined to accept this view. I firmly believe that radio belongs with the phonograph industry or at least it should be sold by phonograph dealers. It would seem that the general merchandising plan used in the disposal of the more expensive radio re-

ceivers that are about to be placed on the market will be very similar to that used to-day in the sale of phonographs. Then, too, we must not forget that the radio, in its present stage at least, is essentially an entertaining device as well as an educational one. Radio and the phonograph must go hand in hand.

"With few exceptions, the radio receiving devices that are on the market to-day are not in the least ornamental. They do not harmonize in any way with the furniture and surroundings of even the most modest home. In general they are encased in a plain cabinet with a number of unsightly knobs, dials and switches arranged on the panel. In the case of vacuum tube receivers a storage battery, with all its

## Why the Talking Machine Dealer Is Admirably Equipped to Give Proper Attention to the Sales of Radio

attending troubles, is necessary. How simple it would be to place these radio receivers in a cabinet with a phonograph and put this troublesome storage battery in the cellar with a plug receptacle on the baseboard. Radio receivers at present are supplied with unsightly tin horns when the perfectly designed wooden horn of the phonograph could be arranged so that the radio receiver could make use of it as well as the phonograph mechanism. It does not take a great deal of foresight to see that the radio receiver as it stands to-day cannot take its place in the American home as a substantial piece of furniture. We all know that the phonograph, in its early days when all the mechanism was exposed, had to meet a certain amount of prejudice on the part of the purchaser. The

thing did not look ornamental enough. It did not look like a piece of furniture.

"Another thing in favor of the phonograph dealer are the facilities he has at his disposal for patrons to listen to the phonograph or the radio music. He already has in his place of business a number of comfortable booths which may be used for the sale of radio instruments as well as for the sale of phonographs and phonograph records.

#### The Question of Stock

"Most every phonograph dealer who contemplates entering the radio field is confronted with the question, 'What kind of instrument shall I buy and who makes the best radio receivers? Shall I stock only finished receivers or shall I include a supply of parts and accessories?' In this respect radio is very much different than the phonograph industry. Among the radio enthusiasts we find a certain class who like to fuss around with independent instruments. They would much sooner go out and purchase a number of parts and assemble them rather than purchase the finished instruments. This class of buyers, however, is by no means in the majority. Probably five per cent of those who purchase radio instruments would care to do this. However, it is true that many people who buy instruments in this way do so not because they are particularly interested in the assembling of the receiver, but because they are forced to do so as a matter of economy. The volume of this part business will, no doubt, be greatly reduced when the time comes that a purchaser can buy an instrument on time payments. There will then be no desire to purchase parts on the part of those who cannot afford a more elaborate assembled instrument.

"For the time being, at least, I would strongly advise every radio dealer to stock a few spare parts simply with the idea of building up a patronage. A man buying apparatus to-day from the dealer will, in the majority of cases, come back to that dealer when he wishes to purchase the finished receiver on the time-payment plan. Of course, aside from these spare parts, every dealer must be able to offer his customers service in the way of battery vacuum tube replacements, crystals, telephones and the many

*The*  
**ECLIPSE  
MUSICAL CO.**  
VICTOR WHOLESALE ONLY  
  
CLEVELAND  
OHIO

**SELLING VICTROLAS  
IS A YEAR AROUND BUSINESS**

The old idea that musical instruments cannot be sold in the summer is a fallacy worthy only of the passing generation of the trade. Everybody doesn't leave town in the summer and those few that do are back in a week to the comforts of home.

Living cost is lower in summer, there is more money to spend and sales competition is less.

The Victor has a style for every season and every home.

**Selling Victrolas is a Year Around Business**







# Emerson Foreign Records

**Foreigners are *Good Customers*  
All Year 'Round**

Do you know? EMERSON FOREIGN RECORDS  
have proven a *most profitable merchandise* in the stores of

**4000 DEALERS**

Comprehensive Catalogues of steady selling records  
are ready in the following languages:

**JEWISH—GERMAN—ITALIAN  
POLISH—RUSSIAN**

**NEW RECORDS JUST OUT**

*Write Us About Them Today and Cash In*

Our efforts are being entirely concentrated upon the production of Standard Records—Exclusive Merchandise that has a 100% Sales Value at all times. This new policy will include, Standard American (Vocal and Instrumental), Operatic, Violin Solos, Instrumental Combinations, Sacred-Holy, Irish Ballads, Irish Instrumentals, Hawaiian and Foreign Records. The policy of concentration will enable us to give Quality and Service.

**EMERSON PHONOGRAPH CO.**

206 FIFTH AVENUE

NEW YORK CITY

**SEVERAL TERRITORIES are open for Jobbing Franchises  
We Invite Correspondence from Responsible Individuals or Firms**





**Wow! Here's a bear cat! Edith Wilson and Johnny Dunn's Original Jazz Hounds break loose in these two "blues" for August.**

**"Mammy, I'm Thinking of You."**

**"Take It 'Cause It's All Yours." A-3634.**

**Columbia Graphophone Co.  
NEW YORK**

## THE SALES POSSIBILITIES OF RADIO

(Continued from page 132)

other necessary little knick-knacks that make up a complete receiver.

"I approach the subject of crystal receivers with no little reservation and with great caution. The crystal receiver is put in a very uncertain position, not only on the account of certain patented and legal matters, but from the standpoint of its lasting power as a factor in the field. With the crystal receiver headsets are absolutely necessary and certainly those people who can afford to spend the amount necessary for a vacuum tube receiver do not care to sit hour after hour with a pair of heavy telephone receivers clamped to their aching ears. I would advise phonograph dealers going into the radio business to purchase this type of instrument with the greatest caution.

"The great demand for radio devices has brought into the field a large number of opportunists and sharpers who are supplying apparatus that cannot be manufactured fast enough by the legitimate houses. As a result of this unfortunate situation the market has been flooded with apparatus of doubtful parentage. In some instances deliberate attempts have been made to hoodwink the buying public with fake devices that function with the lowest efficiency. This condition makes it very difficult for the average phonograph dealer, who does not have any technical knowledge of radio, to go out in the open market and purchase a supply of parts or assembled instruments that will stand up and render efficient service.

"I firmly believe that the phonograph dealers of New York City would do a very wise thing if they established temporarily a central purchasing office or at least enlisted the services of an expert who could steer them clear of the many pitfalls that are apparent. When a man goes into a clothing store for a suit of clothes he usually buys with some sense of value. But not so with radio. Take a pair of headphones, for instance. Many people buy them for appearance, but this is a mistake. In radio ap-

pearance means little or nothing as far as operating efficiency goes. It is the details of construction and design that count.

"We now come to the question of technical service in connection with the sale and installation of radio apparatus. When radio parts are handled the services of a salesman who at least has an elementary knowledge of radio are necessary. If there is one phase of radio merchandising that requires intelligent salesmanship it is that of parts.

"A man with little or no knowledge of radio may come into the store and ask for the parts of a regenerative receiver. He does not know himself exactly what he wants. The clerk or salesman must think for him and help him to purchase the right kind of instrument.

"Installation and maintenance service are another thing that must be considered by the radio dealer. I believe that every dealer should offer free installation with outfits that sell beyond a certain price. In the average case an outfit can be installed at a total cost of five dollars for labor. This service strengthens the bond between the purchaser and the dealer and opens a way for future sales in the form of vacuum tubes, batteries and other replacement articles.

"In closing, let me repeat that I firmly believe that radio belongs to the phonograph dealers since they are best qualified to handle it. The phonograph industry was built up through their patience, understanding and sense of public service. The national sale of radio receivers can be entrusted to them with every assurance of complete success. However, let it be understood that often less qualified agencies are attempting to bring radio into their own fold and if the phonograph dealers want to enjoy their share of this business they will have to go out and fight for it."

## HOUSE FAVORS MILEAGE BOOKS

**Passes Senate Measure Providing for Issuance of Interchangeable Mileage Books or Scrip for Use of Commercial Travelers**

WASHINGTON, D. C., July 8.—The House of Representatives recently passed the Senate Bill authorizing the issuance by the railroads of an interchangeable mileage book. The original bill was amended, however, to permit the Interstate Commerce Commission to determine whether such books should be issued or whether the railroads should place on sale scrip books. The Commission will determine what form the books will take and whether the charge per mile will be lower than the regular tariff.

Various organizations of traveling men, particularly the National Council of Traveling Salesmen's Association, of which the National Piano Travelers' Association is a member, have been fighting for special mileage books for many months, advocating a rate of two and a half cents per mile for bona fide commercial travelers. The interchangeable mileage books will be a boon to all members of the traveling fraternity.

## SPRAGUE RADIO MODELS INTRODUCED

**Prominent New York Manufacturers Make Important Announcement Regarding Plans for the Talking Machine Trade—Strong Staff of Experts Connected With This Company**

A new concern manufacturing radio receiving sets to market in the talking machine trade is the Sprague Radio Corp., of New York, which is manufacturing several models, both console and upright, which are now being introduced in the talking machine field. The personnel of this company are well-known men in the radio engineering field, their experience covering a period of many years in radio sending as well as in receiving. The company is credited with the installation of more radio sending stations in the United States Navy ships and merchant marine than any other company in this country. This phase of the business has been established for many years past, and extensive experiments have been conducted to the end of manufacturing a receiving set that will be of the same high caliber as the other products, mainly the sending stations which the company has manufactured heretofore.

The first models to be introduced to the trade are to retail from \$125 up, depending on the quality of the cabinets and also the number of units with which they will be equipped. It is the plan of the company to market these radio receiving sets direct to the retailer and to give him a discount large enough to enable him to carry a representative stock and also to market it to the consumer at a profit large enough to insure the dealer a stable business.

The officers of the company are: C. W. Sprague, president; Harry E. Sherwin, vice-president and general manager; A. W. Duckett, secretary and treasurer. Well-appointed offices have been opened at 342 Madison avenue, New York City, and the manufacturing is being done in one of the most modern and best-equipped factories in this country, located in Portchester, N. Y., which insures facilities for extensive experiments and room to insure a maximum production and a prompt delivery of all orders. W. H. Knowles, well known in radio engineering circles, is in charge of the factory. He has with him engineers who enjoy a wide reputation as experts in radio engineering circles, such as Harry Shoomaker and Geo. Farrand, who were for many years connected with the radio wizard Marconi in the capacity of consulting engineers, and who also conducted practical experiments and installations of radio sending and receiving stations all over the world. Another engineer of note connected with the factory is William McIntyre, who has had a wide experience in radio receiving.

Mr. Sherwin, general manager of the company, is leaving New York this week for a two months' trip which will take him as far West as the Coast and back again. This trip is for the purpose of visiting retail trade throughout the country and introducing Sprague radio products to the talking machine dealer in each city.

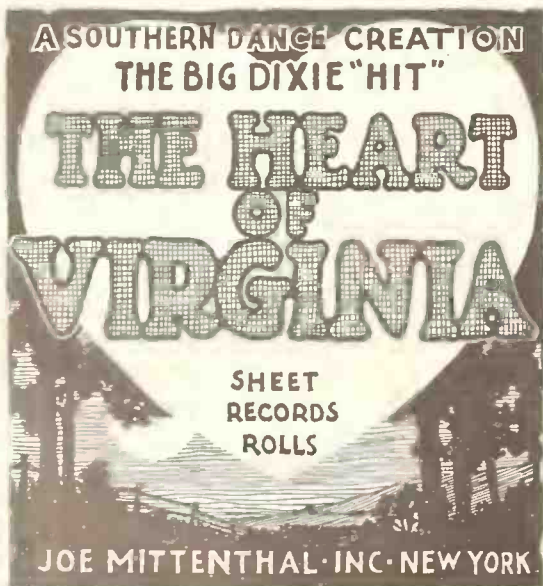



# THREE (3) MILLION DOLLARS

Spent in

# RECORDING

*Now Offered For Sale*

in the form of MOTHER MATRICES 10, 12 and 7 inch

**A Rare Opportunity** for those who are now manufacturing and those who contemplate to manufacture or press 10, 12 and 7 inch Records with their own label and trademark.

**Records** of proven Distinctiveness for compiling a Variety Catalog. This diversified Repertoire consists of the following selections:

- 1200 American Ballads and Dance Selections  
(Standards)
- 50 Rube and Hebrew Dialogues (Comic)
- 50 Marches—Military Bands and Orchestras
- 75 Negro Dialect and Blue Songs
- 35 Instrumental Combinations
- 100 Church Hymns—Holy Songs
- 75 Violin, Piano and 'Cello Solos
- 50 Hawaiian—Ukulele and Guitar
- 50 Operatic Arias
- 400 Hebrew-Jewish
- 70 German
- 300 Italian (Neapolitan and Sicilian)
- 90 Polish
- 12 Russian

Sales Price of Mother Matrices About  $\frac{1}{10}$ th of Our Actual Expenditure

**NOW IS THE TIME FOR YOUR OWN LABEL RECORD**

*Write for any list that is of interest to you*

## APEX RECORDING LABORATORY

1126 Broadway

New York, N. Y.



**OH YOU GOLFERS!**

**AT LAST A "GOLF SONG"**

**A REAL "SPORTSONG"**

# "The 19th Hole"

**A SONG THE "GANG" WILL SING AND ENJOY  
IT'S FUNNY—OF COURSE**

**READY SOON FOR RECORDS AND ROLLS—WATCH FOR IT**

**"You Can't Go Wrong With Any 'Feist Song'."**

## MUSIC WILL DOMINATE PAGEANT

Publicity Director of Forthcoming Chicago Event Details Musical Features of Great Municipal Week Which Opens July 29

CHICAGO, ILL., July 10.—Elaborate preparations are being made for the provision of music during the great Pageant of Progress which will begin on Chicago's Municipal Pier on July 29 and last until August 14. Questioned as to the musical events which are scheduled to take place, John F. Delaney, director of publicity, said:

"With a civic music association of rare ability and indomitable energy, with the most democratic grand opera in the world and with the great symphony orchestra, child of the late Theodore Thomas, as three of its principal musical assets, music will receive marked recognition at the Pageant of Progress Exposition, which opens in Chicago on the Municipal Pier, July 29, to continue until August 14. The bands of Chicago, adult and juvenile, will lend their aid to the harmony of the seventeen days. There will be music from the great Deagan chimes to be set up at the entrance to the pier; there will be the great organ from Northwestern University and scores of choruses, ranging in size from the official Pageant chorus of 250 voices to the 3,500 in the singing organization of the colored people of the city.

"Removing the organ from Northwestern University to Congress Hall on the pier where the musical programs are to be given is a task of interest to builders and manufacturers of musical instruments. The magnitude of the work may be gauged when it is remembered that every pipe, section and cross section must have individual attention, both in the dismantling and in the setting up. When placed in position on the pier the whole great instrument will have to be revoiced.

"Singing of the colored chorus from barges anchored off the pier is expected to be one of the most delightful features of the Pageant. The plaintive lullabies and folk songs of the old South will take on new beauties as they float across the lake.

"Another organization expected to attract attention is the 'President's Own Chorus,' of Mooseheart, Ill., the national home of the Loyal Order of Moose. This chorus, consisting of 1,000 voices, is being trained for the Mooseheart Pageant which President Harding will attend. It will be brought to the Pageant here on Moose Day, August 12, with the Mooseheart band of one hundred players, considered one of the finest juvenile organizations in the country.

"Other choruses will be from the Italian and German singing societies of Chicago, each of approximately 2,000 voices, and another composed of singers from the more than 5,000 church choirs of the city.

"The story of the evolution of music from the most primitive of instruments down to the present day will be told in exhibits by leading manufacturers of the country.

"Among the firms that have taken space for the exposition are: Lyon & Healy, the Steger & Sons Piano Mfg. Co., M. Schulz Co., Starr Piano Co., Samuel C. Osborne Mfg. Co., Martin Band Instrument Co., Ludwig & Ludwig, Chicago Conn Co., Gulbransen-Dickinson Co. and George C. Diver."

## APPOINTED SWANSON JOBBER

Cabinet & Accessories Co. Will Distribute New Portable—Active Sales Campaign Under Way

The Cabinet & Accessories Co., New York (Otto Goldsmith, president), announced this week that it has been appointed a jobber for the Swanson Sales Co., which is the exclusive agent for the Swanson portable phonograph. The Cabinet & Accessories Co. will represent this portable in the metropolitan district and Mr. Goldsmith is keenly enthusiastic regarding the merits of this instrument. According to the

plans of the Cabinet & Accessories Co. an intensive sales campaign will be inaugurated in a few days featuring the distinctive qualities of the Swanson. R. W. Moon, general manager of the Swanson Sales Co., who has been visiting New York the past few weeks, closed this deal with Mr. Goldsmith, and a good-sized shipment is now en route to New York.

## NEW MATHUSHEK MANAGER

The Mathushek & Sons Piano Co. announces that Howard Weber has been appointed general manager of the retail stores of that company, with headquarters at 37 West Thirty-seventh street, New York.

Alexander Rosansky, well known to the metropolitan music trade, has been made general sales manager for Saul Birns, 111 Second avenue, dealer in pianos, talking machines, records, etc.

## HOW ABRAHAM & STRAUS ARE ADVERTISING THE SONORA

**ABRAHAM AND STRAUS INC**

Store Hours: 9 to 5:30 **BROOKLYN** Telephone Main 6100

The Highest Class  
Talking Machine  
in the World.



Baby Grand

\$200

The popular bulge model, beautiful and distinctive, with exclusive Sonora features.

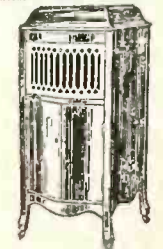

Imperial

\$150

A simple and handsome upright style, remarkable in value.



Queen Anne

\$250

A new period model, with the latest Sonora improvements in tone quality and cabinet design.

Presenting

Some of the newest models of the famous

THE INSTRUMENT OF QUALITY  
**Sonora**  
CLEAR AS A BELL

The Phonograph which won highest score for tone quality at the Panama-Pacific Exposition

It was our pleasure some months ago to add the Sonora line to the vast stock of highest quality merchandise which this store has built up in its years of service to the public.

For many years it has been the custom of Abraham & Straus to search the markets of the world for the best merchandise obtainable in every class.

In the case of the Sonora, both the steadily increasing demand for this superb instrument and our conviction that it stands among the highest achievements in phonograph making, led to its adoption.

The Sonora has won world-wide fame for its clarity and beauty of tone. We offer these instruments in the confidence that they will bring life-long pride and satisfaction to every purchaser. A wide selection of magnificent period and upright models is now on our floors, inviting your examination. These new models embody the latest exclusive improvements in tone quality and construction.

Prices, \$50 and Upward

Terms may be arranged according to your convenience.



The Sonora Portable

\$50

Combining the tone for which Sonora is famous with the utmost compactness. Carries 18 records in its own case. Beautifully bound in calf skin.



Canterbury

\$200

A graceful and dignified model in the exquisite style of Hepplewhite. A. & S.—Fourth Floor, West



**Pablo Casals, than whom there is no greater cellist, has given us in "Would God I Were the Tender Apple Blossom" a tone poem that is marvelous in its beauty. No collection of records is complete without a few good cello selections. You'll go far before you'll find the equal of 80159.**

**Columbia Graphophone Co.  
NEW YORK**



# IN PITTSBURGH

*Healthy Trend to Trade—Spear & Co. Managers Appointed—Machine and Record Shortage Probable—Other News of Interest*

PITTSBURGH, PA., July 10.—Talking machine sales during the past month, while by no means brisk, have shown a very healthy trend, and there is every indication that the bottom of the economic depression has been passed in this section and that the talking machine trade is approaching a better buying season. A decidedly optimistic note is found among dealers and jobbers in all lines and a moderately busy season is anticipated the coming Fall and Winter.

It was announced recently that L. Weinberg, who has had charge of the Victrola department of Spear & Co., and Fred Johnson, of the Johnson Music Co., East Liberty, would assume charge of Spear & Co.'s new East Liberty furniture house at the corner of Broad street and Collins avenue. Mr. Weinberg will serve as manager of the new store, while Mr. Johnson will have charge of the finances. R. R. Myers, formerly associated with the C. C. Mellor Co., has been appointed manager of the Victrola department of Spear & Co.'s downtown store, which position he has already assumed. Mrs. Johnson will take Mr. Johnson's place in charge of the Johnson Music Co.'s store at Pennsylvania avenue, East Liberty.

T. T. Evans, of the C. C. Mellor Co., Victor wholesaler, states that there is no doubt in his mind but that there will be a decided shortage of Victor products during the months of November, December and January. Mr. Evans believes this is due to the fact that the dealers are working on skeleton stocks at this time, with the idea in mind that the jobbers will carry the stocks until they are ready to sell them.

J. C. Roush, president of the Standard Talking Machine Co., Victor wholesaler, spent a few days in the East, visiting the Victor factory and calling upon some of the jobbers nearby. Among the recent callers at the Standard offices were Arthur A. Trostler, secretary of the Schmelzer Co., Kansas City, Mo., and the newly elected president of the National Association of Talking Machine Jobbers; Rayburn Clark Smith, president of the Unit Construction Co., Philadelphia, and Gus Hellman, of the Yahrling-Rayner Music Co., Youngstown, O.

Edward John Fox Marx, local representative of the Victor Co., was married recently to Miss Edith Habbe, daughter of Mr. and Mrs. John Frederick Habbe, of Indianapolis. Mr. and Mrs.

Marx spent their honeymoon at Chautauqua Lake and are now at home in Wilkesburg, Pa.

Kaufmann's Department Stores, Inc., had a week's demonstration in their auditorium for Wallace reducing records and this demonstration produced splendid results.

## NEW OUTING JOBBERS APPOINTED

**Bristol & Barber Added to List of Outing Jobbers—Factory Now Working to Capacity**

The Outing Talking Machine Co., Mount Kisco, N. Y., has closed a number of important deals whereby well-known concerns in different parts of the country will act as distributors for this popular portable, among these new jobbers being the Grafonola Co. of New England, Boston, Mass., and Bristol & Barber, New York. Both of these companies have attained unusual success in their respective territories, and Bristol & Barber have been successful in placing the Outing in a number of the leading retail stores in Greater New York.

A. J. Coté, president of the Outing Talking Machine Co., states that the demand for the Outing portable has far exceeded all expectations and the factory is working to capacity to give the jobbers and dealers efficient service. At the present time the Outing is being distributed in practically all of the leading trade centers and, without exception, these jobbers are enthusiastic regarding the sales value of this portable. They say it has made a most favorable impression.

## SHOW JEWETT RADIO PHONOGRAPH

**A. A. Fair Visits New York to Show New Jewett Product—Trade Enthusiastic Regarding Instruments—Jobbers Now Being Appointed**

A. A. Fair, sales manager of the Jewett Phonograph Co., Detroit, was a visitor to New York recently, accompanied by E. Trowbridge, radio expert, who is associated with the company's radio division. Mr. Fair brought with him several models of the new Jewett combination radio phonograph, which has attracted wide attention throughout the country.

While here Mr. Fair was visited by a number of prominent distributors who evinced keen interest in the combination Jewett radio-phonograph, and negotiations were strated for the distribution of these instruments in important territories. In all probability these deals will be closed in the course of the next few weeks and Mr. Fair is delighted with the reception accorded the new product.

In a chat with The World Mr. Fair stated that the announcement used by the company in the June issue of The World featuring the new Jewett combination instrument had produced a great many inquiries from prominent concerns in all sections of the country. These inquiries are being given careful attention and it is interesting to note that at the present time the Jewett factory is working to capacity to produce sufficient Jewett phonographs to keep pace with the demands of the trade.

TONE TELLS

SOUND SELLS

# The ORANOLA

Reg. U. S. Pat. Office

**"The Perfect Talking Machine"**

The Perfection Talking Machine Co., well-known as the manufacturer of the Oranola (the perfect talking machine) announces an addition to its line of instruments.

## A RADIO CONSOLE

A combination talking machine and radio cabinet, completely equipped, upon which patents are now pending, at present being marketed in console type of cabinet, especially designed for its purposes.

The officers of the company have been identified with the talking machine industry since its inception, and assure the trade of the highest possible quality of workmanship, both in cabinet work and equipment.

A particularly inviting opportunity awaits jobbers and dealers. Exclusive territory. Act at once.

**PERFECTION TALKING MACHINE CO., Inc.** 228 SEVENTH AVE. NEW YORK CITY



FAMOUS VOICES RESURRECTED

Old Edison Recordings by Famous Men Brought to Light in England—Will Be Brought to United States by C. R. Johnstone, General Manager of Bell Recording Corp.

Phonograph records of the voices of famous men, taken more than thirty years ago by one of the first Edison machines sent to England, and buried since that time in the dust of a London warehouse, are to be resurrected and brought to this country late this Summer by Charles R. Johnstone, an English phonograph expert, who made many of the records, and is now general manager of the new Bell Recording Corp., at 9 East Forty-seventh street, New York City.

Among the old cylinders are records of some of the most famous voices of the latter part of the nineteenth century, including P. T. Barnum, Lord Tennyson, Florence Nightingale, William E. Gladstone, Robert Browning, Thomas Bailey Aldrich and Prince Louis Napoleon. They were the first records taken in what was intended to be a great "library of voices," to comprise the human utterances of the noted men in all countries.

Few persons knew of the existence of these records, and early this year, when Professor A. J. Armstrong, of Baylor University at Waco, Texas, undertook to find the old Tennyson records the search for the men who knew something about them took several months of his time. Finally he found Mr. Johnstone, the owner of the records, through the assistance of Frederick Kenyon, of the British Museum.

That search for the Tennyson records by the professor in the Texas University brought to the mind of Mr. Johnstone the idea that the old and dusty records might have great interest for the present generation, and he decided to dig them up in the London warehouse and make some duplicates for use in this country and England.

The finest record of the group, according to Mr. Johnstone, is that of the voice of P. T. Barnum, made while the famous American showman had his "greatest show on earth" in London for a long appearance.

The record of the wonderfully musical voice of Mr. Gladstone was taken at a party at his house. He had sent for the new machine to show his guests the mechanical marvel, and at the end of the entertainment the demonstrator asked him if he would like to speak a few words into the horn. Then, in a strong voice, Gladstone spoke into the recording apparatus a short address to Thomas A. Edison, thanking him for his great invention and praising its value.

Florence Nightingale, England's great nurse, spoke into the horn a few words about the suffering of the soldiers in the Crimea, with a plea for sympathy and help for the wounded.

Speaking of the possible commercial value of the records, Mr. Johnstone said he thought he could make copies of these old master records, which are cylinders, and then put the new masters through the modern process of record-making, so that they could be sold at low prices to schools, colleges, museums or others who wanted them.

JOINS PEARSALL SALES STAFF

Thomas F. Green, president of the Silas E. Pearsall Co., Victor wholesaler, announced this week the appointment of C. A. True as a member of the company's sales staff. Mr. True was manager of the talking machine department of L. Bamberger & Co., Newark, N. J., for many years and has a splendid record.

Andrew Haug, well known in talking machine manufacturing circles, passed away recently at his home, 2659 Nina street, Lamanda Park, Cal., at the age of 53 years. Mr. Haug was formerly associated with the Columbia Graphophone Co., Thomas A. Edison, Inc., at Orange, N. J., and the American Phonograph Co., as factory manager.

INVALUABLE

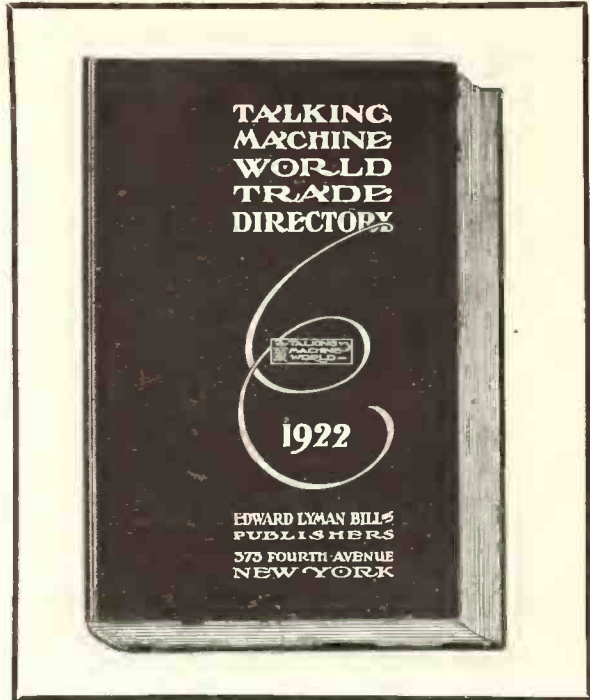

Here is the handbook of the talking machine industry for which you have long been waiting. It is a directory you can keep on your desk to give you, in an instant, detailed knowledge about this and that company, which would otherwise consume much of your time to secure.

ONLY 50 CENTS

For instance, it will give you a complete up-to-date list of the manufacturers and jobbers who comprise the talking machine industry, including invaluable data about each concern, such as location of factories, names of officers, location of branch offices, trade names controlled, policy of marketing product, etc., etc.

ONLY 50 CENTS

Also it will give you a full, up-to-date list of the manufacturers who make any given class of product, such as talking machines, records, parts, accessories, store equipment, etc.

ONLY 50 CENTS

This book contains the kind of data about each concern which cannot be put into the company's current advertising for lack of space and which is nevertheless a kind of data that is valuable from your standpoint.

ONLY 50 CENTS

This volume also contains a number of pertinent articles on highly important topics and much other material too extensive to enumerate here in detail.

ONLY 50 CENTS

It is the only book of its kind ever published and is a volume which no enterprising member of the industry can fairly afford to do without. It has been produced by the publishers of The Talking Machine World.

USE THIS COUPON NOW

Send Cash, Stamps or Check

EDWARD LYMAN BILL, Inc., 373 Fourth Ave., New York City.

Gentlemen: Please send me postage prepaid a copy of the 1922 edition of The Talking Machine World Trade Directory, in payment for which I enclose 50 cents.

Name ..... Firm ..... Street ..... City and State.....

JOINS EIGHT VICTOR ARTISTS

Rudy Wiedoeft, Well-known Saxophonist, Joins This Organization—Prominent in Musical Circles Everywhere—A Valuable Addition

P. W. Simon, manager of the Eight Famous Victor Artists, announced this week that Rudy Wiedoeft, one of the foremost saxophonists in America, would join this well-known organization for the 1922-1923 season. Mr. Wiedoeft has appeared as a vaudeville headliner and as the director of well-known dance organizations in all parts of the country, and he is recognized generally as one of the greatest saxophonists who have ever appeared before the public. His records have attained exceptional success and he will be a welcome addition to the Eight Famous Victor Artists.

Owing to the fact that his plans for the coming season necessitate his stay in New York almost continuously Fred Van Eps, the popular banjoist, who has heretofore appeared with the Eight Famous Victor Artists, will not play with this organization during the 1922-1923 season.

ANOTHER NEW TALKING MOVIE

Remarkable Claims for Invention of Prof. Tykociner, on Which He Has Long Been Working

CHAMPAIGN, ILL., July 11.—After more than twenty years of research Prof. Tykocinski Tykociner, Polish instructor employed by the experiment station of the State University, declares he has invented a method of making talking movies that will work.

By the unique method Prof. Tykociner has perfected it will be possible to photograph acting, the speech of the actors, all noises of nature, such as the wind and the ringing of bells and creaking of doors. Prof. Tykociner believes that this will develop a new art in the movies and that the film industry may be revolutionized.

Prof. Tykociner photographs variations in a manometric flame resulting from sound waves produced by speech at the same time that he photographs the subject. He then photographs these waves by means of a mercury vapor lamp invented by himself for the experiment. The developed negative shows the subject on one side of the film and the sound waves running in a steady line on the opposite side.

When a light is thrown through this film on the wave side and concentrated on a photoelectric cell, an electric current, varying with the volume of light, is set up. The current is amplified many times and run through a loud-speaking phone. The natural voice may then be reproduced distinctly.

SONORA DANCERS WIN HONORS

The sales department of the Sonora Phonograph Co., New York, received recently from W. H. Schermly, Sonora dealer at Durand, Wis.,



First Prize for Sonora Dancers

the photograph shown herewith, representing the Sonora dancing girls who took the first prize at the recent Firemen's masquerade ball held in Durand. The girls in their clever costumes danced to the music of a Sonora portable and the judges were unanimous in giving them first honors.



## WORLD'S CLASSIFIED ADVERTISING

Any member of the trade may forward to this office a "Situation" advertisement intended for this Department to occupy a space of four lines, agate measure, and it will be inserted free. Replies will also be forwarded without cost. Additional space will be at the rate of 25c. per line. If bold faced type is desired the cost of same will be 25c. per line. Rates for all other classes of advertising on application.

**WANTED**—Young man with knowledge of phonograph trade, to operate as traveling sales and service representative. Some experience in selling to phonograph jobbers and dealers desired. Character references required. Fine prospects for advancement with long established firm now manufacturing new line of equipment for the phonograph trade. Write describing education and experience, stating age and salary desired. Address "Box 1165," care of The Talking Machine World, 373 Fourth Ave., New York, N. Y.

**WANTED**—By an old-established mid-West manufacturer of pianos, players, phonographs and records, wholesale salesman for New York and surrounding territory. Must know the Metropolitan trade and be a hustler. We sell on consignment and straight sale. Good opportunity for one who can produce. Address "Box 1167," care of The Talking Machine World, 373 Fourth Ave., New York, N. Y.

**POSITION WANTED**—Young man, graduate, leading musical institute. Specialist in orchestration, harmony, tone quality, and expert accompanist. Wants connection with a laboratory interested in improving the musical value of their product. Address "Box 1168," care of The Talking Machine World, 373 Fourth Ave., New York, N. Y.

**POSITION WANTED**—Experienced and capable man wants position as manager or assistant to manager of radio or phonograph department. Seven years' experience. Address "Box 1170," care of The Talking Machine World, 373 Fourth Ave., New York, N. Y.

**POSITION WANTED**—Technical phonograph laboratory man with 17 years' experience. Can handle work from recording to finished stamper or backed up matrix. Capable of installing and superintending. Wishes interview. Address "Box 1171," care of The Talking Machine World, 373 Fourth Ave., New York, N. Y.

**SALESMAN**—We have certain territories open for live salesman wishing a good, profitable side line—Selling musical instruments and phonograph supplies. Illinois Musical Supply Co., 630 South Wabash Ave., Chicago, Ill.

**POSITION WANTED**—Experienced talking machine man now engaged as manager of large distributing house desires connection possessing larger possible future. Address "Box 1163," care The Talking Machine World, 373 Fourth Ave., New York, N. Y.

**POSITION WANTED**—Young man desires position in music line. Has had several years' experience on the inside and on the road. Address H. Berman, 1243 South Spaulding Ave., Chicago, Ill.

**POSITION WANTED**—Phonograph record salesman; 7 years' experience; wholesale and retail. Address "Box 1164," care The Talking Machine World, 373 Fourth Ave., New York, N. Y.

**POSITION WANTED**—A high-class experienced retail store manager, record stock expert. Can handle every detail of store. Executive ability of highest reference. Open for high class position August 1. Will go anywhere, but prefer the Eastern states. Address "Box 1169," care The Talking Machine World, 373 Fourth Ave., New York, N. Y.

### CASH

for any amount of talking machine records. Address

**Chicago Phonograph Realization**  
315 Union Park Court  
CHICAGO, ILL.

### SPRINGS

<b>VICTOR</b>		
1 1/4"x.022x18' 6" marine ends.....	No. 3014	\$ .58
1 1/4"x.022x17' marine ends.....	No. 3011	.55
1 1/4"x.022x17' bent arbor.....	No. 5362	.57
1 1/4"x.022x13' bent arbor.....	No. 5423	.50
1 1/4"x.022x9' bent arbor.....	No. 5427	.42
1 1/4"x.022x9', bent each end.....	No. 6546	.42
1"x.020x13' 6" marine ends.....	No. 2141	.32
1"x.020x15' marine ends.....	No. 3335	.35
1"x.020x15' bent arbor.....	No. 5394	.38
1"x.020x15', bent each end.....	No. 6546	.43
7/8"x.020x9' marine ends.....	No. 988	.29
<b>COLUMBIA</b>		
1"x.028x10' Universal.....	No. 2951	.32
1"x.028x11' Universal.....	No. 2951	.34
1"x.030x11' hook ends.....		.45
<b>HEINEMAN</b>		
1"x.025x12' motors.....	No. 33 & 77	.32
1 3/16"x.026x19', also Pathé.....		.75
1 3/16"x.026x17'.....	No. 4	.59
<b>MEISSELBACH</b>		
7/8"x10' motors.....	No. 9 & 10	.29
1"x9' motors.....	No. 11 & 12	.29
1"x16' motors.....	No. 16, 17 & 19	.49
<b>SAAL-SILVERTONE</b>		
1"x.027x10', rectangular hole.....	No. 144	.42
1"x.027x13', rectangular hole.....	No. 145	.48
1"x.027x16', rectangular hole.....	No. 146	.58
<b>BRUNSWICK</b>		
1"x.025x12', rect'glar hole, regular...No. 201		.45
1"x.025x18', rect'glar hole, regular...No. 401		.65
1"x.025x16', rect'glar hole.....		.58
<b>EDISON DISC</b>		
1 1/2"x.028x25', regular size disc motors....		1.47
1"x.032x11', Standard.....		.55
1 5/16", Home.....		.70
<b>SMALL MOTORS</b>		
7/8"x.023x10', marine ends, Hein. Col., etc....		.29
3/4"x.025x10', marine ends, Hein. Col., etc....		.27
5/8"x.020x9', marine ends.....		.21
1/2"x.020x9', marine ends.....		.18
Victor Gov. springs, No. 1729.....	per 100	.95
Victor Gov. spring screws, No. 3304.....	per 100	.92
Victor Gov. balls, n/style, No. 3302.....	each	.07
Victor Gov. spring screw washer, No. 3066.....	per 100	.72
Columbia Gov. springs, Unlv., No. 3510.....	per 100	.95
Columbia Gov. spring screws, No. 439.....	per 100	.92
Columbia Gov. spring screw washers.....	per 100	.72
Columbia Gov. ball, lead, flat and spring....		.03
Columbia Gov. ball, steel, new style and spring.....		.08
Turntable felts, all wool, green, 10", round.....		.15
Turntable felts, all wool, green, 12", round.....		.18
Terms 2% cash with order. Free delivery in New York City on all orders of \$25.		

TALKING MACHINE SUPPLY CO., PARK RIDGE, N.J.

### FOR SALE

Music store in Jersey City. Good location, busy transient trade. Agencies for standard makes of phonographs and records. No dead stock. Wonderful opportunity for right man. Address "Box 1173," care The Talking Machine World, 373 Fourth Ave., New York, N. Y.

### Phonograph Booths for Sale

Two Unit Construction Co., sound-proof rooms, 6x9 feet, three record racks, two panel ends, one No. 1 counter, 9-foot arch cornice, 1 extra panel, ivory finish. A complete equipment for phonograph department. Practically new, cost \$1,128; will sell crated for shipment for \$750. Write Gilmore Bros., Kalamazoo, Mich.

### FOR SALE

Want to sell my long-established music and stationery store in busy Wisconsin farming and factory town of 5,000; exclusive Victor agency. Address "Wisconsin," care The Talking Machine World, 373 Fourth Ave., New York, N. Y.

### FOR SALE

Record rack, counter and sound-proof booths for sale. Booths are 6x8 and 8x9, finished in white enamel; double glass. A bargain. Address "Box 1166," care The Talking Machine World, 373 Fourth Ave., New York, N. Y.

### WANTED

Dealers and distributors in every State to sell "Outing Talking Machines," retailing at \$35. The pioneer and the best. Outing Talking Machine Co., Inc., Mt. Kisco, N. Y.

(Continued on page 140)

### BUSINESS OPPORTUNITY

To buy interest in or obtain on royalty basis, manufacture of U-Pla-M record player, as advertised in June Talking Machine World.

**U-Pla-M Record Co.**  
156 East 43rd St.,  
New York, N. Y.

### FOR SALE

100 Very High Grade Mahogany Finished Talking Machines. Fully equipped with best motors and Universal tone arms. Will sacrifice these instruments at an exceptionally low price if taken at once.

**CHICAGO PHONOGRAPH REALIZATION**  
315 Union Park Court  
Chicago Ill.

### WANTED

We are looking for a man who has established relations with the important phonograph manufacturers and who could secure large orders on mica diaphragms for gramophones. Address "Box 1172," care The Talking Machine World, 373 Fourth Ave., New York, N. Y.

### Second-hand Magnavoxes Wanted

We pay the best cash prices for second-hand Magnavoxes. Send description of your machine and we will make offer. Warnax Mfg. Co., 346 Canal St., New York, N. Y.

### WANTED

Dealers and distributors in every State to sell the So-ave-tone line of talking machines. The machine with a personality. The J. K. Mohler Co., Ephrata, Pa.

### Cash

For any amount of talking machine records.

**BARNEY OLSHANSKY**  
315 Union Park Court  
Chicago, Ill.

### BOOTHS FOR SALE

Booths (6) for phonograph store. Made by Jyostrom, Philadelphia (in white enamel), cost \$3,000, price \$350.00 F.O.B. Philadelphia. Fred A. Brown, 203 W. Allegheny Ave., Philadelphia, Pa.

### FOR SALE

High-grade phonograph panels and mouldings in K. D. form, mitered and drilled for dowels. Gum and Quartered Oak. Will sell lot of 200 at sacrifice. Address V. M. Cottle, Waukegan, Ill.



THE TALKING MACHINE WORLD'S CLASSIFIED ADVERTISING—(Continued from page 139)

**FOR SALE OR RENT  
PHONOGRAPH  
Recording Laboratory**

Completely equipped for all classes special and regular commercial work. Established trade. Address inquiries, "Recording Laboratory," care The Talking Machine World, 373 Fourth Ave., New York, N. Y.

**For Sale**

200,000 Standard Make Phonograph Records. Wide Variety of selections.

**CHICAGO PHONOGRAPH  
REALIZATION**

315 Union Park Court, Chicago, Ill.

**FOR SALE**

Splendid music store in southern California city of 15,000. Only exclusive music store in town. Carries a fine line of pianos and has the only Victor's agency in the city. Forced to sell because of ill health. A wonderful opportunity for a live man. Can be handled for \$8,000 to \$15,000. Address "Box 1174," care The Talking Machine World, 373 Fourth Ave., New York, N. Y.

**FOR SALE**

Music house, well established for 14 years in a large middle West city. Pianos and Victor and Brunswick Depts. High-class clientele. Good reason for selling. All cash preferred, but terms to reliable party, or parties. Address "Box 1161," care The Talking Machine World, 373 Fourth Ave., New York, N. Y.

**FOR SALE**

Genuine Pathé sapphire needles. 12 cents each for cash. The Pathé Shop, 228 West Grand River Ave., Detroit, Mich.

**FOR SALE**

Several thousand standard make records, late numbers, also sacred, instrumental standard numbers, etc., at thirty-five cents each. Send for catalog. Central Phonograph Co., 127 N. 11th St., Philadelphia, Pa.

**BUSINESS OPPORTUNITY**

**WANTED**—Salesmen to sell a line of metal nameplates to talking machine dealers and manufacturers. Big profits. No bulky samples. Commission paid on receipt of orders. Can be handled in connection with any line. Write for our proposition to-day. Fogarty Manufacturing Co., Dayton, O.



**PIANO  
BOOKS**

**T**HE Edward Lyman Bill, Inc., technical library represents the only books written in English for the men who constitute the piano and player-piano industry of the United States. Each book covers its respective subject clearly and completely. Each volume is the standard work of its particular field. Every one of these books should be in the hands of every progressive man who wants to help keep the American piano industry the world's leader, both from an artistic and commercial standpoint.

**Modern Piano Tuning**

A very comprehensive book covering principles and practices of tuning, regulation of piano action, elementary principles of pneumatics, general construction of player mechanisms, repair of old pianos or player mechanisms. 331 pages, \$2.00.

**Theory and Practice of Pianoforte Building**

An essential book for every manufacturer, scale draftsman, superintendent, dealer or piano salesman. The only work of its kind in the English language. 160 pages, fully illustrated, tables, diagrams, etc., \$2.00.

**Player-Piano Up to Date**

The best available source in English for player-piano knowledge. Principles of construction, regulation and use of pneumatic mechanisms. Descriptions of leading mechanisms. For salesmen, tuners, repairmen, etc. 195 pages, illustrated, \$1.50.

**Regulation and Repair of Pianos and Player Mechanisms**

Indispensable for salesmen and executives in piano factories, two books in one, illustrated, tables, diagrams. 158 pages, \$1.50.

**Mail This Inspection Coupon**

Edward Lyman Bill, Inc.  
373 Fourth Ave., New York City.

You may send me on five days' free inspection the book or books I have marked. I will return them to you within five days or remit \$..... in full within ten days.

Name .....

Address..... City.....

**Mark which books you want to see**

<input type="checkbox"/>	Modern Piano Tuning
<input type="checkbox"/>	Theory and Practice of Pianoforte Building
<input type="checkbox"/>	Regulation and Repair
<input type="checkbox"/>	The Player Pianist
<input type="checkbox"/>	Player-piano Up to Date

**Phonograph and Music Dealers**

Victor compound is a real money maker of quality for the progressive dealer. An easy seller and sure repeater. Nothing like it on the market. Free sample and full information to established dealers. Address Victor Chemical Co., Box 195, Battle Creek, Mich.

**CARVED LEGS**

Eight designs in gum, oak and mahogany. Prices reduced. Send for circular. Klise Mfg. Co., Grand Rapids, Mich.

**Recording Laboratory For Sale**

Recording machine, shaving machine, wax, lateral recording heads, motors, etc., etc. Perfect condition. May be seen in operation. Complete, without plating, \$500, or best offer. Opportunity for party desiring to make lateral disc records. Address "Box 1175," care The Talking Machine World, 373 Fourth Ave., New York, N. Y.

**RECENT TALKING MACHINE EXPORTS**

Exports of Machines and Records in April Announced by the Department of Commerce

Exports of phonographs and records now amount to more than a quarter of a million dollars a month, according to figures which have just been made public by the Department of Commerce, showing our export trade in April. The department reports that 4,406 phonographs, valued at \$154,891, and 196,750 records, valued at \$101,912, were exported during the month.

Our most important market for phonographs is Canada, whose imports in April amounted to 1,317 machines with a value of \$50,486. Japan was the next most important market, taking 986 machines with a value of \$30,834, and Mexico was third with 382, valued at \$13,754. Mexico, however, was our most important market for records, taking 26,743, valued at \$12,528, while Argentina was second with 19,156, valued at \$11,346. Other large exportations were 26,669, valued at \$10,732, to Australia, and 13,826, with a value of \$10,379, to Chile.

**FEATURE COLUMBIA RECORD**

Detroit Music Co. Makes Attractive Display of "Smilin' Through"

DETROIT, MICH., July 6.—The Detroit Music Co., of this city, recently featured an effective window display in connection with the Columbia record. "Smilin' Through." In this window placards were presented calling attention to the fact that this well-known motion picture is being shown at the local theatres and also mentioned that the Columbia record may be purchased at that establishment. Columbia dealers throughout the country have been featuring this record by Oscar Seagle, which is proving very popular.





# EUROPEAN HEADQUARTERS

2 GRESHAM BLDG., BASINGHALL ST., E.C. LONDON

W. LIONEL STURDY, MANAGER

Music Trade Convention the Dominating Happening of Month—Topics of Interest to Gramophone Dealers Discussed—Hire Purchase System Considered—Radio Development in the Trade in Great Britain—Invicta Record Co. in Liquidation—Interesting Views on German Reciprocity—Association Discusses the Subject of Unsalable Records—News of the Month

LONDON, ENG., July 4.—A feature of dominating interest in the British trade during the past month was naturally the music trade convention which was held at the Hotel Metropole, Blackpool. All agree that it was the best convention ever. From a point of attendance—well over 200 delegates, with a sprinkling of the fair sex—it established a record. President Louis Sterling handled the business side admirably; his tireless energy, tact and good humor won general praise. Lt. Col. R. H. Tatton, organizing director of the Federation of British Music Industries, under whose auspices the convention was held, and the various secretaries and officials of each Association worked hard to make the convention the great success it was from both a business and social viewpoint.

There were two or three business sessions each morning, the rest of the day being given over to pleasure. Of the subjects discussed—and generally the program was a heavy one—that which most interests my readers relates to the talking machine industry. The great question of unsalable records and their exchange by the manufacturers resulted in a very animated discussion among a big meeting of retail dealers from all parts of the country. The three to one exchange

met with general condemnation as being mutually inimical to dealers and makers. As will be seen by the following report some very good suggestions were put forward as a solution of the difficulty and there is every reason to believe manufacturers will accept the 10 per cent exchange proposal. Here is the report:

At the meeting of the Gramophone Dealers' Association, which was held recently, the chair was occupied by E. Rasin Jones, of Manchester, the president of the Association, who said in part: "We are not working for ourselves alone. The committee is working for the whole of the gramophone trade and especially of the members of the G.D.A. and we may say that the relations existing between the manufacturers and the G.D.A. are most friendly. If anyone thinks we are out, as an Association, to use force, let me tell him he is greatly mistaken; our policy is not force, but reason and right. You have a paper asking for answers to seven questions. We would be very much pleased if every member of this Association, and every gramophone dealer here, will answer those questions because by so doing you will enable us to form some idea as to what you desire and require."

Joseph Riley, Birmingham, speaking on the "Limitation of Catalogs and the Disposal of Unsalable Records," said: "If the catalog is a big one we have to stock the lot. We don't mind stocking all these records if we can sell them all, but our Association thinks that no maker's list should exceed 2,500, and if the manufacturers can only cut the catalog down to all good sellers, we should be able to get them to agree to take the old ones off as they put the new ones on. When

we find a record is dead we want to return it to the manufacturer. We don't want to create a museum of dead records. We ought to be able to part with these records or come to some arrangement with the manufacturers by which we could return them before their sale is finished in certain districts. For instance, in certain districts a record may be absolutely finished and if it came to Blackpool for a little fresh air it might live a little bit longer. The point is we don't want to bring it into the drapery trade where we can have sales once a year or every three months. We believe in price maintenance and if the manufacturers would come along and enable us to get rid of the unsalable stock then the record business would be a very sound one. On the question of exchange we think dealers should be entitled to return 10 per cent of their purchases every six months with credit in full."

M. E. Ricketts said on the subject: "I think a dealer has a right to know to a small number how many records a manufacturer intends to place in his catalog, what space will be necessary for racking purposes and to know approximately how much money he will have to invest in that side of his business. Unsalable records in the main consist of two kinds: badly chosen titles, which is not the fault of the dealer, and well chosen titles issued late, when the market has gone. If a dealer has 100 records to send back and a company says to him: 'You must take three to one,' that is, 'You have to take 300 before we give you credit for that 100,' is that in the best interests of the dealer or the public? Well, anyone who knows anything about this business

(Continued on page 142)



"His Master's Voice"

Copyright

**This intensely human picture stands for all that is best in music**

—it is the "His Master's Voice" trade-mark, and it brings to you, no matter where you are, the very best music of every kind, sung and played by the world's greatest artists—the greatest singers, pianists, violinists, orchestras and bands—all enshrined in the unequalled "His Master's Voice" records

## 'His Master's Voice'

—the trade-mark that is recognized throughout the world as the

## HALL-MARK OF QUALITY

**DENMARK:** Skandinavisk Grammophon-Aktielselskab, Frihavn, Copenhagen.

**FRANCE:** Cie. Française du Gramophone, 115 Boulevard Richard Lenoir, Place de la République, Paris.

**SPAIN:** Compañia del Gramofono, 56-58 Balmes, Barcelona.

**SWEDEN:** Skandinaviska Grammophon-Aktiebolaget, Drottning Gatan No. 47, Stockholm.

**RUSSIA:** The Gramophone Co., Ltd., 45, Nevsky Prospect, Petrograd (Petersburg); No. 1 Solyanka, Solyanoi Dvor, Moscow; 9, Golovinsky Prospect, Tiflis; Nowy-Swiat 30, Warsaw; 11 Michallovskaya Ulitsa, Baku.

**INDIA:** The Gramophone Co., Ltd., 139, Balhaghatta Road, Calcutta; 7, Bell Lane, Fort, Bombay.

**AUSTRALIA:** S. Hoffnung & Co., Ltd., Sole Concessionaries of The Gramophone Company, Limited, 163, Pitt Street, Sydney.

**NEW ZEALAND:** Gramophonum, Ltd., 118-120 Victoria Street, Wellington.

**SOUTH AFRICA:** Darter & Sons, Post Box 174, Capetown; Mackay Bros., Post Box 261, Johannesburg; Mackay Bros. & McMahon, Post Box 419, Durban; Ivan H. Haarburger, Post Box 106, Bloemfontein; Frans Moeller, Post Box 108, East London; B. J. Ewins & Co., Post Box 86, Queens-town; Handel House, Kimberley; Laurence & Cope, Post Box 132, Bulawayo; The Argue Co., Salisbury.

**EAST AFRICA:** Bayley & Co., Lourenzo Marques.

**HOLLAND:** American Import Co., 22a, Amsterd Veerkade, The Hague.

**ITALY:** A. Bossi & Co., Via Orefici 2, Milan.

**EGYPT (Also for the Sudan, Greece and the Ottoman Empire):** K. Fr. Vogel, Post Box 414, Alexandria.

**Great Britain:**

**The Gramophone Company, Ltd.**

**HAYES**

**MIDDLESEX**

**ENGLAND**



## FROM OUR LONDON HEADQUARTERS—(Continued from page 141)

knows the answer is 'No.' The manufacturer says, 'You will have to take three to one'; what happens? A month or two or three weeks before those records are to be sent back the dealer begins to hold up his orders until he can collect orders for 300 records. Then he gets his 100 and sends in an order for 300. That 300 comes in and he fills the depleted racks. But what has really happened? That man has been without records which he should have had. The manufacturer does not sell one record more, and the public has not had the service it has a right to demand. With regard to the remarks of Mr. Jones and Mr. Riley, that the gramophone business can only be a success so long as the dealers are absolutely friends and partners with the manufacturers, that is the only way in which any big industry can be a success, and therefore this should not be made a question of fighting between the dealers and the manufacturers. When you get down to the bed-rock the dealers' interest is the manufacturers' interest. Therefore, I would suggest that the manufacturers should go into this matter properly and come down to this point. It will very likely be a matter of compromise. Supposing they were to say to the trade, 'We are going to cut off 100 records and you people that are stocking our goods in sufficient quantities for the needs of your district, send them all back to us,' what does it mean to the manufacturers? The loss is not a great one. It is the cost of the pressing minus the material. That is the loss. If you take the royalties of the artists, I believe the manufacturers will agree with me when I say that they would not even lose their royalty stamps. So that if I am correct the manufacturers can say to dealers, 'You are making as much as we are out of this business; the loss will average 6d.; you bear 3d. and we will bear 3d.' I don't say those are the exact figures, but a committee of manufacturers and dealers could in forty-eight hours settle the whole question."

Ernest Marshall, opening the discussion on "The Hire Purchase System as Applied to the Gramophone," remarked: "We have arrived at a decision on the question of the percentage basis that 10 per cent should be added to the cash price. It was the decision not only of the committee but of a general meeting of our members. It is subject to modification or alteration and so that we should not merely discuss the matter we have circulated certain questions which we want you to just put a simple answer 'Yes' or 'No' to in reply to each one. Now, we are dealing here with the hire purchase as applied to the gramophone, and the dealer says that the gramophone business is a little more risky than the piano business, as the gramophone is more easily removed and is more difficult to trace. In all these matters we are not opposing the manufacturers. This is always a friendly discussion and it is very unfortunate that a company happens to adopt methods that the trade is against. The question is, 'What is a fair rate of interest to charge?' You have the question to answer as to whether you are in agreement with the 10 per cent being added to the cash price or not. One company has introduced, as you all know, this new method of hire purchase business. We in our Association were extremely interested in this new method. We did not turn it down and we did not take any antagonistic view. Our committee got into communication with the company and asked them if they would kindly send the best exponent of that system to us. This was eighteen months or two years ago. The business was explained and the dealers who were present, I think there were somewhere about forty, on a vote at

the end were unanimously agreed against that system. We are not out to fight against it. You know the difficulties. I am sure I need not go into details of it. A dealer feels that when you are talking percentages, when you are talking about adding so much in the pound on the outstanding balance you are putting the hire purchase business to the customer in the worst light. It is better to say as a dealer says, 'Add 5 per cent to the cash price,' but if you say '10 per cent on outstanding' balance it sounds a lot, but it is the same thing. The next question is whether it is wise to have a great deal of competition in this question advertised. For instance, suppose we got one firm saying, 'We do our business on the hire purchase system at 2½ per cent' and another firm at 5 per cent, another 6 per cent, and so on. Is it not better to keep on to the old method, so much cash down and so much per week? One other point—the question of deposit, as to whether the amount we add to the cash price should be taken into consideration in the question of the deposit. Supposing we were adding 10 per cent on the amount and the man was paying £5 down, should we deduct that £5 from the cash price before adding the 10 per cent? The consensus of opinion is that if the instalments were level it should not be taken into consideration, but if a reasonable deposit be paid down then it should be deducted. It is rather a difficult matter to lay a hard and fast rule upon. There is another question and that is the limit of time for payment. Do you think all machines supplied under £40 should be paid for in a period not longer than twelve months, and if a machine is at a higher price, say £60 to £80, for a longer period. There is also the question whether a deposit of 10 per cent is satisfactory."

W. Holmes said: "We have made a rule, with a few exceptions, that we have half the price down and 5 per cent added to the remaining half, payable within six or twelve months according to the value of the machine. We find it works very well indeed. Our losses have been cut down to almost nothing and it is a very simple way out of the difficulty."

The various members present discussed the question at length, a number of them being of the opinion that being forced to demand a fixed increase over the cash price would play into the hands of competitors. In fact, several merchants testified to their experience in that direction.

#### Brunswick Activity in England

If the opinion be correct—and it has been freely expressed by men who should know—that American recordings, particularly on the instrumental side, be superior to our best here, then without a doubt the proposed distribution of Brunswick records through a London center should meet with a hearty reception. I can personally testify to an appreciation of your Brunswick discs, having been privileged to hear an advance series recently received by Alfred Graham & Co., of Crofton Park, London, S. E., and Saville Row, W. I may not be far wrong in stating that this consignment evidently foreshadows a move towards the marketing here of this record which, I believe, has secured a deservedly high reputation in the States. It would, perhaps, be somewhat premature to go into details at this stage of the negotiations between the two firms, but, undoubtedly at an early date something of interest to the trade and the gramophone enthusiast will develop along definite lines. There are several matters of policy yet to be decided. The scale upon which distribution will be carried out is still under consideration, and it is not yet possible to indicate a definite policy in regard to prices and conditions of sale, etc. Whatever this aspect of the business may resolve itself into, the fact remains that at Messrs. Graham's West End salon, so centrally situated, anticipations point toward a substantial retail trade in Brunswick records from this branch alone. The wonderful "Algraphone" series of instruments made by this firm, of which in all there are 101 models at prices from 15 to 750 guineas, are the admiration of the gramophone world. To conform with this high-grade

standard of production Mr. Graham has chosen the Brunswick record. In my judgment a very happy and appropriate combination, which coupled with the fine organization and enterprise of this British house should quickly exert a big influence to the good of and throughout the whole industry. More anon!

#### Wireless as It Affects the Music Industry

The subject was appropriately enough raised at the British music convention at Blackpool by E. Brinsmead Gough, who conducts a live retail business within the London area. Owing possibly to an overfull convention program, which curiously enough gave no mention of this new science, Mr. Gough unfortunately failed to get a proper hearing. That his remarks were taken up by many newspapers shows how lively is the general interest in what has been described as "the miracle in a little box." Thousands of these little miracle boxes are now being sold here so that the public may sit at home and "listen in" to concerts, news, or whatever is radiating around. We are at the dawn of a new era, and it is the far-seeing folk like Mr. Gough who are going to reap benefit by directing the wireless apparatus trade into the right channel. It is nobody's perquisite at the moment, but the gramophone dealer will need to wake up, and that quickly, if he would take advantage of the present opportunity. Who more fitted to develop this new business advantageously than the musical instrument dealer? Would you place it with the photographic dealer, the electrical apparatus shop—so restricted in number—the cycle dealer? No! By character, environment and intelligence, the musical shop undoubtedly represents the best retail channel through which wireless home apparatus should pass to the public. The music dealer once made a mistake in ignoring the gramophone when it first came along, with the result that much of the trade was for years lost to another branch of industry, i. e., the cycle shops. Success doesn't consist in never making mistakes, but in never making the same one twice. Let us remember that and get to grips now with this wireless musical broadcasting scheme.

The idea that wireless may supplant home music to some extent and reduce the demand for pianos, gramophones, etc., is not supported by Louis Sterling, president of the Federation of Music Industries, who in the course of an interview said: "In the march of science there has never been a great invention yet that had not been in the long run of incalculable benefit to the industry with which it was concerned. When gramophones were invented people said they would kill pianos; the cinema was fully expected to give the quietus to the legitimate stage; vaudeville was at first looked on as the death dance of musical comedy. None of these things had happened, and the new had in every case benefited the old. Appetite grew on what it fed upon, and the more good music the people got from broadcasting the more they would want from their own gramophones and pianos. But we in the music industry are very jealous that the broadcasting firms should give the best, there is no room for bad music."

One of the first gramophone firms to make a move in the direction of home wireless apparatus is Messrs. J. T. Hough, Ltd., of Edison Bell fame. In conjunction with Messrs. Elwell, Ltd., radio engineers, they have been working on some interesting mechanism which, the result of much experiment, is bound to claim universal attention at the appropriate time.

A combination wireless receiving set and gramophone amplifier is also under way by Messrs. Alfred Graham & Co., Crofton Park, London, S. E. Mr. Graham tells me that he has been working on it for some time. His extensive knowledge and experience of this branch of the trade is the outcome of many years' actual production of telephone and electrical apparatus, microscopes and such-like, of which Messrs. Graham were one of the chief sources of supply during the war. In Mr. Graham's opinion the development of the new wireless business here cannot be so rapid as in the States because of the many existing official restrictions, and of a somewhat involved situation regarding patents.

## Horn, Hornless and Table-Grand GRAMOPHONES

FOR

## EXPORT

Please State Your Requirements

REX GRAMOPHONE CO. 2 Elizabeth Place  
Rivington Street, LONDON, E.C. 2, England  
Cable Address "Lyrecodisc, London"



FROM OUR LONDON HEADQUARTERS—(Continued from page 142)

The Marconi Co. apparently holds the key to the situation. This firm, by the way, is doing a big business in wireless apparatus and, in fact, it is literally besieged with applications.

Most of the big London stores are handling the business and are meeting with great success.

**H. M. the King of Siam Ass.sts Recording**

Among the many interesting items in the Gramophone Co.'s "The Voice" is a reference to news from Bangkok that during a recent recording session the king granted exceptional facilities to the "H. M. V." recorder. Records were not only taken at the Royal Palace, but His Majesty instructed leading artists to place themselves at disposal and in one case specially commanded an artist to return from up-country for the purpose of recording. It is stated that the "His Master's Voice" expert was as much gratified as surprised at the unusual interest displayed by the King of Siam.

**Invicta Record Co., Ltd., in Liquidat.on**

A meeting of the creditors of the above company was held June 12, following upon an extraordinary general meeting, when a special resolution was passed that the firm be wound up voluntarily. A. C. Simmons, 1 New Inn Yard, London, E. C., the appointed liquidator, informs me that the interests of the two directors, Messrs. Barrand and Barton, have been purchased by the Aeolian Co., Ltd. Mr. Barrand has now retired from business altogether, and Mr. Barton proposes to establish a new business as a merchant. The Invicta Co. was well known as the maker of the "Guardman" record.

**Annual Meeting of Gramophone Association**

On June 28 was held the annual meeting of the Association of Gramophone and Musical Instrument Manufacturers and Wholesale Dealers, whereat was discussed the best method of disposal of unsalable records, having regard to the interests of manufacturer, jobber and dealers.

**Business News of Interest**

Though the actual figures of our imports and exports for April (the last available) show a decrease over those for March, allowing for the number of working days, the April totals are comparatively better. A slight but welcome indication of trade improvement.

The latest returns of the cost of living show a drop of 95 points since November, 1920, when the figure was 176 points above the pre-war level. The reduction is getting proportionally less each month, as expected, but there is a decrease each month and, however slight it may be, it's a good sign of more purchasing power. That's the point!

The great engineering strike is over, thanks be. Many thousands of men have returned to work. Also, after eleven weeks on strike 20,000 Mersey shipyard workers have resumed.

In March and April, owing to trade disputes resulting in lockouts and strikes, etc., it is estimated that no less than 9,000,000 working days were lost. No wonder there's little money for the purchase of gramophones!

We have still over 1,500,000 men and women unemployed. Others who are not registered and

those on short time may number an additional half million. That trade is gradually on the mend is indicated by the fact that the decrease of unemployment is now something between 30,000 and 40,000 per week.

On the other hand reports from Germany show that not one person in a hundred is unemployed. Out of 6,000,000 workmen only 51,000 are known to be idle.

**The London Fair and Market**

The above exhibition at the Agricultural Hall, London, is for the most part of a trade character. Its life is short, July 3 to 14, but during this period a substantial amount of good business is registered. Among the exhibitors are several musical instrument firms, including A. J. Balcombe, Ltd., who are showing a range of small goods and gramophones, and the C. H. Roberts Manufacturing Co., whose wonderful portable, the "Bestone," is creating an unusual amount of interest this side. An unique selling feature is the three years' full guarantee given with each machine!

**V. F. Record Wins Favor**

The higher class gramophone trade has welcomed the Edison Bell "Velvet Face" records, which were introduced a few months ago. It just means that on quality alone the V. F. has won a well-justified position on the shelves of the big dealers throughout the country. Recent issues embrace some fine chamber music by the Royal Symphony Orchestra, Michael Zacharewitsch, the Philip Lewiss Palladium Octet, the Royal Military Band, etc. An unique contribution is by Guido Gialdini, described as the greatest exponent of the whistling art. On the vocal side are some really good records by the lady tenor, Miss Ruby Helder, Margaret Wray and Robert Carr.

Messrs J. E. Hough also announce some exclusive recordings on their popular "Winner" record. Interest will center on some Jewish selections by the Rev. Meyer Formin, Ober Cantor of the Glasgow Synagogue. As a contrast, the Blackpool Tower Orchestra has been laid under tribute for the recording of a series of fox-trots and waltzes—just the type most popular with almost every class of the community.

**The "H. M. V." Easy Payment Scheme**

At the Blackpool music convention, also at the Scottish gathering, gramophone dealers exhibited opposition to the above scheme. The principle never for a moment came under question, the scheme so far as it develops a new channel of trade proving welcome. What dealers condemn is the method by which the scheme is worked, i. e., the adding of interest on the capital balance remaining over each month. At the two conventions referred to, many dealers expressed the view that this method is too complicated, especially from the customer's point of view. The Gramophone Dealers' Association registered its opposition some time ago and sent a delegation to the company, so far, I believe, without result. Dealers require to handle the hire-purchase prop-

osition, as they put it, on the straightforward basis of a definite extra percentage on the cash price, the whole payable in fixed monthly instalments over a given period.

The Gramophone Co. has circularized its dealers on the subject to (in part) the following effect:

"It is recognized that the old system of charging customers a heavy rate of interest has been the means of restricting trade, while our scheme is creating confidence and good feeling, which will cause sales to increase enormously. This is no mere theoretical statement, but is made as the result of practical experience.

"Announcements in the press, giving particulars of the scheme, have already been made by dealers, and we are considering the advisability of setting forth its advantages in those great newspapers in which our advertisements appear regularly, when all inquiries would be sent to those who have adopted our scheme.

"The easy payment system is the coming great sales force in the gramophone industry, and under our scheme the possibilities are unlimited."

**German Reciprocity**

An illuminating instance of German ideas on commercial reciprocity in the music trades has just come to light, says the Federation of British Music Industries. More than a year ago a leading gramophone maker wished to send three gramophones into Germany. He was informed that they could not be sent without an import license from the German Government and has been trying unsuccessfully for twelve months to obtain the required permission.

Another manufacturer sent experts to Germany to make records by native artists for distribution among the German population in the United States. The German Government refused permission for these records to leave the country. Representations were made through diplomatic channels, but the sole concession granted was that if the surfaces of the wax "master" records were scratched and defaced, then only would the goods be allowed to leave the country.

On the other hand, a German gramophone maker, who acquired the factory and plant of a British company in Germany during the war, has now issued catalogs identical with those of the former owners and is offering the records at ridiculously low prices. Many of the artists, being under exclusive contract with the British company, are receiving substantial royalties from that company. The German manufacturer pays no royalties and is offering the records throughout the world (United Kingdom excluded at present—Editor) at prices below the bare costs of manufacture in this country.

The German gramophone manufacturers have clearly succeeded in inducing their Government to keep out every outside competitor while they themselves ship their goods freely into this country and compete on unfair terms with the British manufacturers in foreign markets.

**EDISON BELL**

**WINNER**  
TRADE MARK  
**GRAMOPHONE RECORDS**

CABLE  
"PHONOKINO,  
LONDON"

**ARE THE GREATEST VALUE FOR MONEY PRODUCED IN GREAT BRITAIN**

TEN INCH

DOUBLE SIDED

NEEDLE CUT

**PLAY ON ALL GRAMOPHONES**

**Catalogue contains 4000 Titles by the Premier Artistes, Instrumentalists, Orchestras and Bands of the British Empire**

DEALERS PREPARED TO DO BUSINESS ARE INVITED TO COMMUNICATE WITH

**Proprietors and Manufacturers, J. E. HOUGH, Ltd., 62 Glengall Road, London, S. E. 15, England**



# LATEST PATENTS RELATING TO TALKING MACHINES AND RECORDS

WASHINGTON, D. C., July 8.—Gramophone Record Brush. John Priespilis, Brooklyn, N. Y. Patent No. 1,414,302.

This invention relates to brushes for cleaning phonograph record plates or the like, and has for its object to produce a brush adapted to keep the record grooves clear of dust and the tiny shavings produced by the needle while reproducing a record. A further object is to provide means for elastically mounting the brush in such manner that it will readily follow the needle and

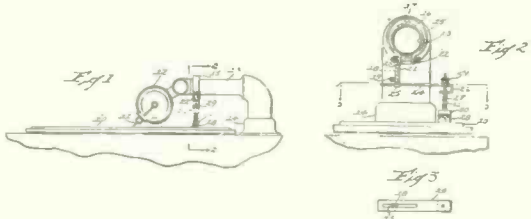

yield when meeting obstructions or uneven spots, and which allows a securing of the brush to tone arms of varying diameter.

Figure 1 is a side view of a record plate, sound box, needle and tone arm with the brush constructed according to the invention mounted thereon. Fig. 2 is an enlarged detail view partly in section taken along line 2—2 of Fig. 1. Fig. 3 is a top plan view of a guide strip.

Talking Machine Record and Method and Apparatus Therefor. Daniel Higham, East Orange, N. J. Patent No. 1,414,185.

This invention relates to recording of sound waves for a talking machine record, and its object is to so provide for this recording that the distortions ordinarily made in recording and reproducing sound waves can be correctly compensated for.

With present recording means and methods, the amplitude of the recorded sound wave is reduced in amount by the opposing action of the recorder diaphragm, and the lower the pitch, with relatively greater amplitude of the sound wave, the greater the ratio of this reduction of amplitude of the recorded sound waves will be, compared to the original sound waves.

Figure 1 is a side elevation, partly in section, of means for carrying the method of recording into effect. Fig. 2 is a view, partly in section, looking from the left to Fig. 1 with certain parts removed from the left of the dash line V. Fig. 3 shows a portion partly in section; Fig. 4 a

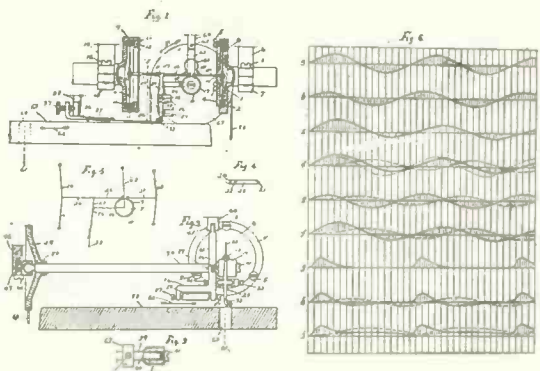

part in another view. Fig. 5 is a diagram showing a different position of parts of Fig. 1; while Fig. 6 graphically shows the performance of the method of recording as distinguished from present recording, and the distinguishing performance of each when operating the present reproducer.

Phonograph. Henry Orsenigo, Mount Vernon, N. Y. Patent No. 1,414,151.

An object of the invention is to provide a phonograph with movable panel or closure member for the discharge opening of the phonograph and open to view for the purpose of enhancing the phonograph as an article of furniture when not in use as a phonograph and to provide means for mounting such panel or closure member to conceal such panel when removed. Such provision of means affords a suitable ar-

angement whereby the motor of the phonograph is placed in operative connection automatically upon concealing such panel in its opening position and automatically effecting non-operative relation of the motor and the phonograph parts when the panel or closure member is in its viewed position.

Figure 1 is a perspective view of a phonograph embodying the invention, showing the panel in position when the phonograph is not in operation. Fig. 2 is a similar perspective view partially broken away to show hidden parts and showing the panel moved to its concealed position and the contact member of the motor circuit closed, in which relation the grill-work of the phonograph is shown to view. Fig. 3 is a

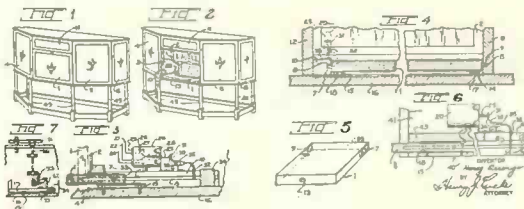

detail sectional view on line 3—3 of Fig. 2; Fig. 4 in a detail sectional view on line 4—4 of Fig. 3. Fig. 5 is a detail perspective view of the panel; Fig. 6 is a detail perspective view similar to Fig. 3 showing a modification, and Fig. 7 shows a further modification.

Phonograph Cabinet. Joseph Janes, Somerville, Mass., assignor of one-half to G. Clay Cox, Rochester, N. Y. Patent No. 1,414,086.

This improvement consists of a phonograph cabinet of such character that it may be used as an ordinary library table for writing, holding book, a lamp, etc., thus combining in one the functions of the two articles of furniture, especially desirable in a small apartment. It comprises means for supporting the phonograph mechanism, starting, stopping it, etc., automatically in a way convenient for changing records.

Figure 1 is a perspective view of a table, the phonograph support or drawer being open to enable the record to be changed or the needle adjusted. Fig. 2 is a cross section on line 2—2 of Fig. 3. Fig. 3 is a partial horizontal section

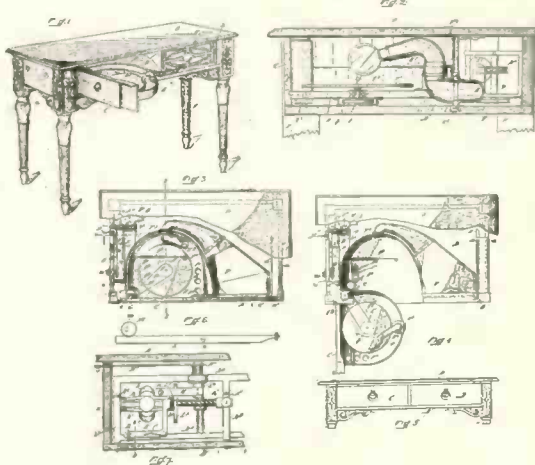

showing the parts as ordinarily arranged when out of use. Fig. 4 is a corresponding view, the drawer carrying the record table being open. Fig. 5 is a partial front elevation of the table when the drawers are closed and the phonograph out of use, and Figs. 6 and 7 are details.

Phonograph. Frank A. Lee, Cincinnati, O., and Frank G. Rose, Dayton, Ky., assignors to the John Church Co., Cincinnati, O. Patent No. 1,413,919.

This invention relates to megaphones for phonographs. The object is to so influence the sound waves produced by the phonograph that said waves are amplified, intensified, made richer in quality and clarified, so as to reproduce more nearly the actual quality of the sound waves imparted from the phonograph record to the phonograph diaphragm.

Figure 1 is a sectional perspective view of part

of a phonograph in which the invention is embodied in its preferred form. Fig. 2 is a detail perspective view of the megaphone of a phonograph, together with a throat according to the invention, but modified from that shown in Fig. 1, the megaphone being shown in longitudinal section. Fig. 3 is a detail perspective view of the megaphone and throat shown in Fig. 1, but the view being from the rear. Fig. 4 is a similar

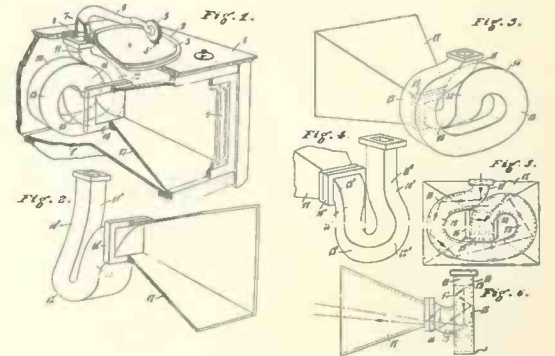

view of part of the megaphone and another modified throat according to the invention. Fig. 5 is a rear elevation of the megaphone and throat shown in Figs. 1 and 3; and Fig. 6 is a side elevation of the same.

Sound Modulator for Phonographs. Nils Seaholm, Mount Vernon, N. Y. Patent No. 1,414,673.

This invention relates to a modulator or sound modifier for graphophones or phonographs and the like. It more particularly appertains to a device interposed between the stylus of a sound-reproducing machine and the sound box thereof by means of which the audibility of the acoustic waves may be regulated.

Figure 1 is a side elevation showing this improved device in operative position with respect to a sound box and a record of a phonograph of well-known type. Fig. 2 is an enlarged sectional elevation of the device alone, in a position conducive to the maximum softening of the sound. Fig. 3 is a top plan view of the de-

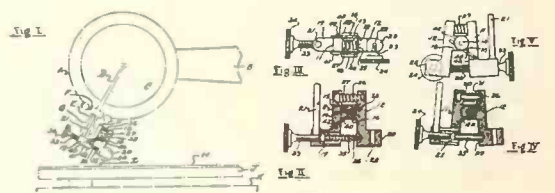

vice shown in the preceding figure. Fig. 4 is a view similar to Fig. 2, showing the device in a position corresponding to a minimum of tone suppression; and Fig. 5 is a rear elevation of the device in the position seen in the last-named view.

Graphophone. Leopoldo Roberto, Philadelphia, Pa. Patent No. 1,414,898.

This invention has particular reference to the tone arm sound box mounting of the talking machine or graphophone.

This invention has many objects, among the most important being the provision of a graphophone wherein the tone arm is freely detachable therefrom with the hinged cover of the graphophone box constituting a sounding board upon which the outlet end of the tone arm is supported.

Figure 1 is a side elevational view of a graphophone constructed in accordance with the present invention, a portion of the sectional tone arm and sound box being moved to inoperative position and illustrated by dotted lines. Fig. 2 is a top plan view of the same. Fig. 3 is a front elevational view of the tone arm with the hinged section thereof elevated to inoperative position. Fig. 4 is a horizontal sectional view taken on line 4—4 of Fig. 3, showing the rotatable connection between the tone arm and the supported bell end thereof. Fig. 5 is a cross-sectional view taken on line 5—5 of Fig. 1, showing the stylus arm of the sound box connected to the dia-



PATENTS RELATING TO TALKING MACHINES AND RECORDS—(Continued from page 144)

phragm. Fig. 6 is a front elevational view of the removable elbow of the tone arm for supporting the sound box. Fig. 7 is a side elevational view of the removable elbow of the tone

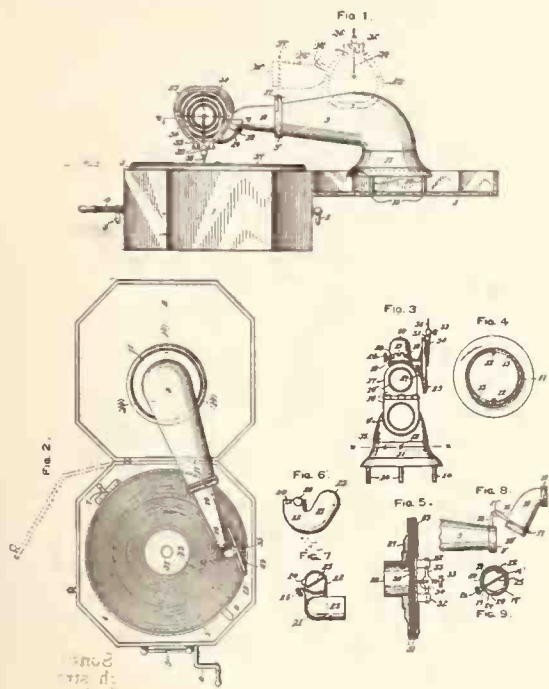

arm. Fig. 8 is a fragmentary side elevational view of the inner end of the tone arm showing the hinge connection between the sections thereof, and Fig. 9 is a cross-sectional view showing the connecting means between the elbow section and the hinged end of the tone arm.

**Sound-deadening Device for Phonograph Reproducers.** Ernest F. Dahlheim and Walter S. Hulet, Minot, North Dakota. Patent No. 1,414,937.

This invention relates to new and useful improvements in sound-deadening or regulating devices for phonograph reproducers and has for its primary object the provision of a device of the above stated character which may be easily and quickly applied to an ordinary sound box and is provided with means for regulating the vibration of the vibratory transmitter bar so as to increase and decrease the sound and thereby obviate the employment of different types of styluses now used for such purpose.

Figure 1 is a side elevation of a sound-deadening or regulating device applied to a repro-

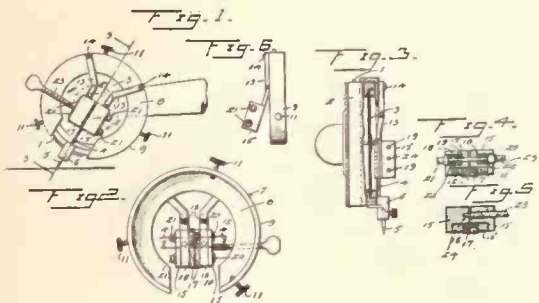

ducer and constructed in accordance with the invention. Fig. 2 is a rear elevation illustrating the same and removed from a reproducer. Fig. 3 is a sectional view illustrating the device applied to a reproducer. Fig. 4 is a detail sectional view illustrating means for urging the clamping members into engagement with the vibratory transmitter bar. Fig. 5 is a detail sectional view illustrating an adjustment for the clamping arms or members. Fig. 6 is an edge view, illustrating a modified form of the invention.

**Repeating Attachment for Talking Machines.** Everett G. Clements, Washington, D. C. Patent No. 1,414,980.

This invention relates to repeating attachments for "talking machines," and has for its object to provide means whereby such machines can be started into operation with a single record and will repeat the reproducing of the matter on the record continuously without requiring the attention of an operator. It further relates to means whereby the repeating apparatus may be adjusted to automatically return the needle from the point where it has completed the traversing of the record to the point of beginning, to accommodate records of various lengths or diameters. The object of said invention is to produce such a mechanism which will not only be automatic in its action, but will be simple and inexpensive in construction and positive and reliable in its operation.

Figure 1 is a top plan view of the rotary record bearing table, such as commonly em-

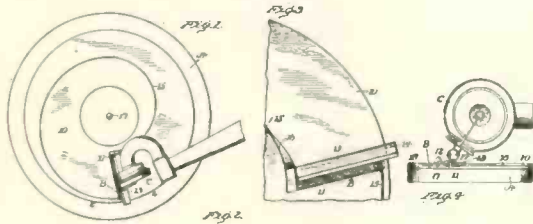

ployed on a machine of the type described, with a record disc thereon, and also illustrating the attachment as it appears in position for use. Fig. 2 a transverse section on the dotted line 2-2 in Fig. 1. Fig. 3 a detail plan view on an enlarged scale (practically full size) to illustrate more clearly the adjusting features of the invention, and Fig. 4 an edge view of the attachment.

**Phonograph Reproducer.** George B. Burch, New York, assignor to Leslie Stevens, Glen Ridge, N. J. Patent No. 1,414,803.

The invention relates to phonograph reproducers, and more particularly to improvements in means for vibrating the sound-reproducing diaphragm, and the invention aims to provide such means which shall be simple in construction, durable and highly efficient in transmitting vibrations from the record to the diaphragm so that a very perfect reproduction of the recorded sounds may be secured.

Figure 1 is a sectional view of a phonograph having a reproducer embodying the invention.

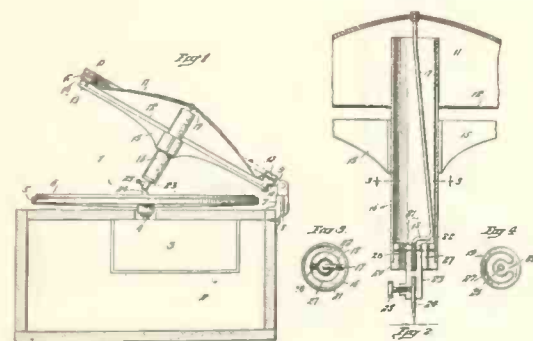

Fig. 2 is an enlarged sectional view of a portion of the diaphragm, stylus holder, transmission rod and connected parts. Fig. 3 is a sectional view, taken on the line 3-3 of Fig. 2, looking in the direction of the arrows. Fig. 4 is a plan view of a disc, which supports one end of the transmission rod.

**Phonograph.** George B. Burch, New York, assignor to Leslie Stevens, Glen Ridge, N. J. Patent No. 1,414,804.

The object of this invention is to provide a phonographic apparatus which requires no amplifying horn and which is efficient in operation and accurately reproduces all sounds recorded in the record and yet is simple in construction and efficient in operation.

Figure 1 is a sectional view of the instrument. Fig. 2 is a sectional view showing the stylus holder, transmission rod and connected parts. Fig. 3 is a sectional view taken on the line 3-3 of Fig. 2, looking in the direction of the arrows. Fig. 4 is a sectional view showing the

lower part of the structure shown in Fig. 2, the section being taken at right angles to that of Fig. 2. Fig. 5 is a sectional view showing a portion of the diaphragm and a portion of the rim of

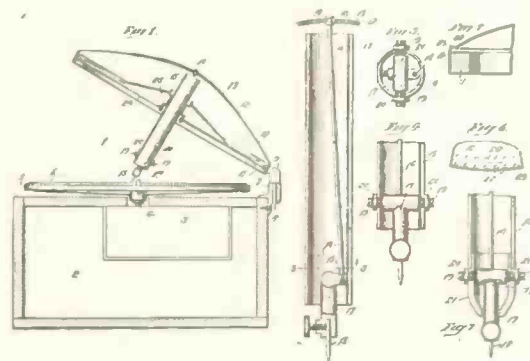

which it is mounted. Fig. 6 shows a portion of the edge of the diaphragm. Fig. 7 is a sectional view showing a slightly modified construction in and about the stylus holder.

**Reproducer.** Martin Jones, Philadelphia, Pa., assignor of one-half to Joseph S. MacLaughlin, same place. Patent No. 1,415,361.

One object of this invention is to provide a sound box or reproducer for talking machines which shall be capable of so affecting the sound waves as to produce the required volume of sound without being as heavy as is at present the practice. By reason of the resulting lightening of the reproducer structure there is a reduction of the pressure upon the record and a consequent increase in the life of the latter.

The invention also contemplates a novel arrangement and form of intermediate diaphragm whereby the above noted desirable results are obtained and also a construction whereby vi-

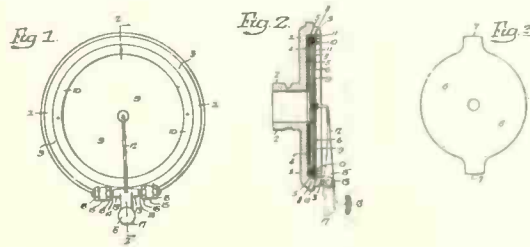

bration of the body of the box is prevented or damped, as are also certain objectionable metallic noises commonly produced when records of a certain class are played.

Figure 1 is a plan of a sound box or reproducer constructed according to the invention. Fig. 2 is a vertical section on the line 2-2, Fig. 1; and Fig. 3 is a plan of the auxiliary diaphragm forming part of the invention.

**Diaphragm Attachment.** Joseph E. Jones, Waltham, Mass. Patent No. 1,415,360.

This invention relates to diaphragm attachments, especially designed for use in connection with such diaphragm construction as used upon the Edison phonograph.

Another object of this invention is the production of a very simple and efficient means for attaching the cord to the diaphragm in such a manner as to permit the cord to be released

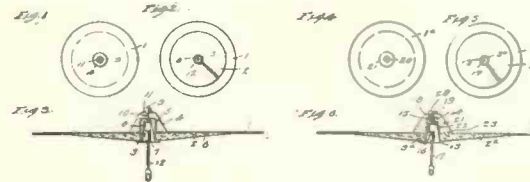

from the diaphragm when so desired and replaced should occasion arise.

Figure 1 is a top plan view of the diaphragm. Fig. 2 is a bottom plan view thereof. Fig. 3 is a central transverse sectional view through the diaphragm. Figure 4 is a top plan view of a modified form of the diaphragm which will be known as the friction cone construction. Fig. 5 is a bottom plan view of the diaphragm attachment shown in Fig. 4, and Fig. 6 is a central transverse sectional view through the diaphragm.

Lederer Feibelman, Inc., of Terre Haute, Ind., is planning to add a music department to its department store in that city.

# REPAIRS

All Makes of Talking Machines Repaired Promptly and Efficiently

REPAIR PARTS FOR ALL MACHINES

**ANDREW H. DODIN**

28 Sixth Avenue

New York

TELEPHONE, SPRING 1194



Advance RECORD BULLETINS for August, 1922

COLUMBIA GRAPHOPHONE CO.

- SYMPHONY RECORDS
49988 Blue Danube Waltz—Soprano Solo, Rosa Ponselle 12
80159 Would God I Were the Tender Apple Blossom—Violoncello Solo...Pahlo Casals 10
A3619 Believe Me If All Those Endearing Young Charms—Baritone Solo...Oscar Seagle 10
A3617 Irish Love Song—Contralto Solo, Cyrena Van Gordon 10
A3616 Gypsy Serenade—Violin Solo...Eddy Brown 10
A3623 Kiss Me Again (Intro. "Waltz" from "Mlle. Modiste")—Hawaiian guitar, Hawaiian banjo and ukulele trio...Louise-Ferera-Greenus 10
A3591 Blue Lodge March...Prince's Band 10
A3622 Skeeter and the June Bug—Baritone Solo, Harry C. Browne 10
A3618 The Low Backed Car—Tenor Solo...Edwin Dale 10
A3626 Coo-Coo—Comedian...Al Jolson 10
A3633 Atta Baby—Comedienne...Nora Bayes 10
A3632 Here Comes Dinah, Belle of the Ball—Tenor and Baritone Duet...Furman-Nash 10
A3625 My Yiddisha Mammy—Tenor Solo, Irving Kaufman 10
A3634 Mammy, I'm Thinking of You—Comedienne and Jazz Band...Edith Wilson and Johnny Dunn's Original Jazz Hounds 10
A3629 I Love Her, She Loves Me (From "Make It Snappy")—Fox-trot, Ray Miller and His Orchestra 10
A3631 Kicky-Koo, Kicky-Koo—Fox-trot, Eddie Elkins' Orchestra 10
A3635 Swanee Blue Bird—Fox-trot...California Ramblers 10
A3636 Gypsy Love Song (Intro. "Good Morning Chorus" and "She Said, 'I Was So Lonely,'" from "The Fortune Teller")—Medley Waltz, Prince's Dance Orchestra 10
A3620 You Won't Be Sorry—Accordion Solo, Guido Deiro 10
POPULAR SONGS
A3624 I Love Her, She Loves Me (I'm Her He, She's My She, from "Make It Snappy")—Comedian, Eddie Cantor 10
A3630 Who'll Take My Place?—Comedienne, Marion Harris 10
DANCE RECORDS
A3628 Parade of the Wooden Soldiers (From "Chauve Souris")—Fox-trot, Ray Miller and His Orchestra 10
A3621 Sweet Indiana Home—Fox-trot...The Columbians 10
A3627 Those Longing for You Blues—Fox-trot, Frank Westphal and His Rainbo Orchestra 10

VICTOR TALKING MACHINE CO.

- POPULAR SONGS
18906 Stumbling...Billy Murray 10
18908 Rock Me in My Swanee Cradle...Peerless Quartet 10
18909 I Certainly Must Be in Love...Billy Murray 10
DANCE RECORDS
18895 Lonesome Mama—Fox-trot...The Virginians 10
18907 Moon River—Waltz, Green Bros.' Marimba Orchestra 10
18910 Soothing—Fox-trot, All Star Trio and Their Orchestra 10
18911 It's Up to You—Fox-trot, Paul Whiteman and His Orchestra 10
18912 Syncopate—Medley Fox-trot...Club Royal Orchestra 10
18913 Nobody Lied—Fox-trot...The Virginians 10
VOCAL AND INSTRUMENTAL RECORDS
45313 Violets...Merle Alcock 10
45314 We Would See Jesus...Olive Kline-Elsie Baker 10
45315 Mighty Lak' a Rose...Alberto Salvi 10

RED SEAL RECORDS

- LUCREZIA BORI, Soprano
87344 When Love Is Kind...Thomas Moore 10
EMILIO DE GOGORZA, Baritone
66072 I Know a Lovely Garden, Teschemacher-D'Hardelot 10
MISCHA ELMAN, Violinist
66073 La Cinquantaine (The Golden Wedding), Gabriel-Marie 10
FLONZALEY QUARTET, String Quartet
74746 Quartet in D Major—Adagio Cantabile (2nd Movement) (Op. 64, No. 5)...Haydn 12
AMELITA GALLI-CURCI, Soprano—In French
66069 Coq D'Or—Hymne au Soleil (The Golden Cock-erel—Hymn to the Sun)...Rimsky-Korsakow 10
BENIAMINO GIGLI, Tenor—In French
66070 Le Roi d'Ys—Vainement, ma bien aimée (The King of Ys—In Vain, My Beloved)...Lalo 10
MARIA JERITZA, Soprano—In German
74760 Tannhäuser—Elisabeth's Gebet (Elizabeth's Prayer)...Wagner 12
ERIKA MORINI, Violinist
66074 At the Fountain (Am Springbrunnen), Robert Schumann 10
PHILADELPHIA ORCHESTRA
Leopold Stokowski, Conductor
74758 Tannhäuser Overture—Part 1...Wagner 12
74759 Tannhäuser Overture—Part 2...Wagner 12
OLGA SAMAROFF, Pianist
66075 Spring Song...Mendelssohn 10

EDISON DISC RE-CREATIONS

- 50921 Spagoni's Wedding Jubilee...Billy Murray 10
50922 Polonaise Militaire...United States Marine Band 10
50923 My Melancholy Baby...Walter Scanlan 10
50924 The "Knocker"—Character Recitation...Edward Clark 10
50925 Fireflies...Reed Orchestra 10
50957 Hearts and Flowers—Piano Solo...Walter Chapman 10
50985 When You and I Were Young Maggie Blues, Billy Jones and Chorus 10
80716 Davy Jones Locker...Fred East 10
80717 Where My Caravan Has Rested...Lewis James 10
80718 Carnival of Venice—Variations—Cornet Solo, Bohumir Kryl 10
82262 A Song of Thanksgiving...Anna Case 10
82263 Serenade—Les Millions d'Arlequin—Violin Solo, Albert Spalding 10
51007 Hungarian Dance No. 1—Violin Solo...Albert Spalding 10
50987 Parade of the Wooden Soldiers—Novelty March from "Chauve Souris"...V. Lopez Orch. 10
50988 I'm Just Wild About Harry—Fox-trot—Introducing "Bandana Days" from "Shuffle Along"...Vincent Lopez Orchestra 10
50989 Stumbling—Fox-trot...Atlantic Dance Orchestra 10
50991 Hawaiian Nightingale, Palakiko's Hawaiian Orchestra 10
50992 Flower of Hawaii...Palakiko's Hawaiian Orchestra 10
50990 Sweet Indian Home—Fox-trot—Introducing "Bamboo Bay"...Broadway Dance Orchestra 10
51004 The Yankee Doodle Blues—Fox-trot, Broadway Dance Orchestra 10
51005 Just Keep On Smiling...Broadway Dance Orchestra 10
50993 Sing Song Man—Fox-trot (A Chinese Fox-trot), Natzy's Orchestra 10
50994 (a) Flow Gently, Sweet Afton; (b) Bonnie, Sweet Bessie—American Guitar Solo...R. Truckess 10
80729 Old Black Joe...Thomas Chalmers 10
51003 Swanee Bluebird—Fox-trot, Broadway Dance Orchestra 10
51006 I Certainly Must Be in Love...Marguerite Farrell 10

EDISON BLUE AMBEROL RECORDS

- 4557 Pick Me Up and Lav Me Down in Dear Old Dixieland—Medley Fox-trot—Introducing "My Mammy Knows"...Don Parker Trio 10
4558 The Laughing Girl Has Her Picture Took—Norwegian-English Monologue...E. C. Olson 10
4559 Mountain Maid...George Wilton Ballard 10
4560 On a Little Side Street—Medley Waltz—Introducing "Baby's Eyes"...Piano Solo...E. L. Stevens 10
4561 Jevinsky's Jubilee—Vandeville Specialty...Julian Rose 10
4562 S'peep Little Babv of Mine...Helen Clark 10
4563 On the Alamo—Fox-trot...Harry Raderman's Orchestra 10
4564 Love Sends a Little Gift of Roses...Lewis James 10

- 4565 Save a Little Dram for Me...Duke Rogers 10
4566 Crossing the Bar...Criterion Quartet 10
4567 Tbe Little Tin Soldier or (The Little Rag Doll), The Homestead Trio 10
4568 Ida—Caprice...Reed Orchestra 10
4569 Of Thee I'm Thinking, Margareta...Albert Lindquest 10
4570 Good-bye, My Baby... "We Girls" Quartet 10
4571 Georgia—Medley Fox-trot—Introducing "Malinda Brown"...Don Parker Trio 10
AMBEROLA HITS FOR AUGUST
4592 Hearts and Flowers—Piano Solo...Walter Chapman 10
4593 I'll Dream of You—Fox-trot...Vincent Lopez Orchestra 10
4594 Suppose the Rose Were You—Fox-trot, Ernest L. Stevens' Trio 10
4595 Idola—Fox-trot—An Orientale Fantasy, Natzy's Orchestra 10
4596 I Love Her; She Loves Me—Fox-trot from "Make It Snappy"...Atlantic Dance Orchestra 10

BRUNSWICK RECORDS

- TWENTY-EIGHTH RELEASE
15025 Mamma Mia Che Vo Sape (Neapolitan Song)—(Nutilo)—Tenor with Neapolitan Orchestra, Mario Chamlee 10
'A Vuchella (A Little Posy) (D'Annunzio-Tosti)—Tenor with Neapolitan Orchestra, Mario Chamlee 10
13050 Within the Garden of My Heart (Roberts-Scott)—Tenor with Orchestra...Theo Karle 10
Non E Ver ('Tis Not True) (Mattei)—Tenor with Orchestra...Theo Karle 10
13051 Good Night Quartet (From "Martha") (Flotow)—Mixed Quartet with Orchestra, The Music Art Singers (Marie Tiffany, Elizabeth Lennox, Theo Karle, Richard Bonelli) 10
Madrigal (From "The Mikado") (Sullivan)—Mixed Quartet with Orchestra, The Music Art Singers (Marie Tiffany, Elizabeth Lennox, Theo Karle, Richard Bonelli) 10
5141 Gypsy Love Song (From "The Fortune Teller") (Victor Herbert)—Baritone with Orchestra, Richard Bonelli 10
Bedouin Love Song (Pinsuti)—Baritone with Orchestra...Richard Bonelli 10
5142 Serenade (Sing, Smile, Slumber) (Ground)—Flute Obligato—Soprano with Orchestra...Virginia Rea 10
The Swallows (Bingham-Cowen)—Soprano with Orchestra...Virginia Rea 10
2278 A Bunch of Roses (El Punao de Rosas) (Chapi)—Spanish March—Xylophone with Orchestra...George Green 10
Intermezzo (Introduction to Act III) (From "Jewels of the Madonna") (Wolf-Ferrari)—Xylophone with Orchestra...Joseph Green 10
2279 Kiss Me Again (From "Mlle. Modiste") (Victor Herbert)—Violin with Orchestra...Frederic Fradkin 10
Roses of Picardy (Weatherly-Wood)—Violin with Orchestra...Frederic Fradkin 10
2280 Soothing (Storman-Fiorito)—Fox-trot—For Dancing...Oriole Terrace Orchestra 10
Lovable Eyes (From "Make It Snappy") (Atteridge-Schwartz)—Fox-trot, For Dancing, Oriole Terrace Orchestra 10
2281 Swanee Bluebird (Friend-Conrad)—Fox-trot—For Dancing...Bennie Krueger's Orchestra 10
Sweet Indiana Home (Walter Donaldson)—Fox-trot For Dancing...Bennie Krueger's Orchestra 10
2282 Song of Persia (Radford-Egan-Whiting)—Fox-trot—For Dancing...Carl Fenton's Orchestra 10
Parade of the Wooden Soldiers (From "La Chauve Souris") (Jessel)—Fox-trot—For Dancing...Carl Fenton's Orchestra 10
2283 Where the Volga Flows (Ley-David-Katzman)—Fox-trot—For Dancing...Rudy Wiedoeft's Californians 10
Suez (Pancoast-Grofe-De Rose)—Fox-trot—For Dancing...Rudy Wiedoeft's Californians 10
2284 Stumbling (Zez Confrey)—Comedienne with Orchestra (With Bennie Krueger's Orchestra) Margaret Young 10
Nobody Loves Me Now (Tracey-Arndt)—Comedienne with Orchestra...Margaret Young 10
2285 Just a Little Love Song (Young-Lewis-Cooper)—Baritone with Orchestra...Ernest Hare 10
Only a Smile (Edson-Zamecnik)—Baritone with Orchestra...Ernest Hare 10
2269 Indiana Lullaby (Terriss-Kendall)—Tenor and Baritone with Orchestra, Charles Hart and Elliott Shaw 10
I Certainly Must Be in Love (Tracey-Dougherty)—Tenor with Orchestra...Billy Jones 10

AEOLIAN CO.

- DANCE RECORDS
14355 Coo-Coo (Al Jolson-Bud DeSylva)—Fox-trot, Bar Harbor Society Orch. 10
Romany Love (J. S. Zamecnik)—Fox-trot, Bar Harbor Society Orch. 10
14356 Deedle-Deedle Dum (Al Sherman-Coslow and Mills)—Fox-trot, Emil Coleman and His Montmartre Orch. 10
Blue-eyed Blues (Billy Fazioli)—Fox-trot, Emil Coleman and His Montmartre Orch. 10
14357 Panorama Bay (James Monaco-Grant Clark)—Waltz...Bar Harbor Society Orch. 10
Swanee River Moon (H. Pitman Clarke)—Waltz, Bar Harbor Society Orch. 10
14363 Just Because You're You (That's Why I Love You) (Turk-Robinson)—Fox-trot, Yerkes' S.S. Flotilla Orch. 10
The Sneak (H. Nacio Brown)—Fox-trot, Yerkes' S.S. Flotilla Orch. 10
14370 Rose of Bombay (Ward-Dyson)—Fox-trot, Emil Coleman and His Montmartre Orch. 10
Sing-a-loo (Mitchel-Pollock)—Fox-trot, Emil Coleman and His Montmartre Orch. 10
FOUR NEW POPULAR SONGS
14358 Why Should I Cry Over You? (Cohn-Miller), Irving Kaufman 10
I Wish There Was a Wireless to Heaven (Manuel-Harry White-Willy White), Irving Kaufman 10
14371 The Sheik of Avenue "B" (Kalmar-Ruby), Monroe Silver 10
Big-hearted Jim (Ryan-Violinsky)...Billy Jones 10
A WONDERFUL INSTRUMENTAL LIST
14364 Stars and Stripes Forever (Sousa)—March, Matt's Band (Late Bandmaster of Seventh Regiment, N. G., N. Y.) 10
National Emblem (E. E. Bagley)—March, Matt's Band (Late Bandmaster of Seventh Regiment, N. G., N. Y.) 10



ADVANCE RECORD BULLETINS FOR AUGUST—(Continued from page 146)

- 14353 Light Cavalry Overture (Franz von Suppe)—Accordion Solo ..... A. Palet Gallarini 10
- Marche Lorraine (Ganne)—Accordion Solo, A. Palet Gallarini 10
- 24028 Liebesfreud (Kreisler)—Cello and Piano, Maurice Dambois 10
- Canzonetta (Du Port-Dambois)—Cello and Piano, Maurice Dambois 10
- 14362 Bummel Petrus ("Jolly Peter") Kersten-Werner) ..... Metropolitan Dance Players 10
- Warum-dem-Weinen (Hirsch), ..... Metropolitan Dance Players 10
- 14354 Irish Jig Medley (Intro. "Paddy in London," "Butcher's March," "Sligo Bay"), Tom Ennis, Irish Pipes; Jas. Morrison, Violin; John Muller, Piano 10
- Irish Reel Medley (Intro. "New Steamboat," "Bucks of Orammore," "Gardner's Daughter"), 10
- 14367 A Mahina Malamalama ("Lazy Moon")—Waltz, Ferrera Trio 10
- Ua Like No a Like ("Sweet Constancy"), Ferrera Trio 10

FAVORITE OPERATIC SOLOS

- 52036 Pagliacci—Prologue (Leoncavallo)—Baritone, Giacomo Rimini 12
- 52038 Il Barbiere di Siviglia—La Calunnia e un Venticello (Ah, Calunmy Is Like a Zephyr)—Basso, Virgilio Lazzari 12

SEVEN EXCELLENT STANDARD RECORDINGS

- 30157 Lo, Here the Gentle Lark (Shakespeare-Bishop)—Soprano ..... Evelyn Scotney 10
- 14368 All Thru' the Night (Old Welsh Air) (Boulton)—Baritone ..... Elliott Shaw 10
- Can't Yo' Heah Me Callin', Caroline? (Gardner-Roma)—Tenor ..... Vernon Dalhart 10
- 35011 The Kerry Dance (Molloy)—Tenor..Charles Hart 12
- The Moon Has Raised Her Lamp Above (Benedict)—Tenor and Baritone, Charles Hart-Elliott Shaw 12
- 14359 Rock-a-bye Baby (Butterworth-Norris)—Mezzo-Soprano ..... Helen Clark 10
- At Dawning (Eberhard-Cadman)—Soprano, Grace Kerns 10

A VARIETY OF SACRED SONGS

- 52037 The Holy City (Weatherly-Adams)—Baritone, John Charles Thomas 12
- 14350 New Old Story (Syme-Pierson)—Contralto, Carolyne Burns 10
- Hold Thou My Hand (Briggs)—Contralto, Carolyne Burns 10
- 14351 Brighten the Corner Where You Are (Ogden-Gahriel)—Baritone ..... Homer Rodeheaver 10
- I Shall See the King (Rowe-Ackley)—Baritone, Homer Rodeheaver 10
- 14352 The Church in the Wildwood (Dr. Wm. S. Pitts), Criterion Quartet 10
- The Gospel Train (C. Austin Miles), Criterion Quartet 10

OKEH RECORDS

CLASSICAL SELECTIONS ODEON RECORD

- 52902 La Traviata—Dei miei bollenti spiriti (Wild My Dreams of You) (Verdi)—Tenor, with Orch. (Sung in Italian) ..... Alfred Piccaver 12
- This record was recorded in Europe by the International Talking Machine Co. and is pressed in the United States by the General Phonograph Corp.
- EUROPEAN SYMPHONY ORCHESTRA
- 3014 The Dusk of the Gods (Siegfried's Funeral March, Part 1)—Orchestra, European Symphony Orchestra 12
  - The Dusk of the Gods (Siegfried's Funeral March, Part 2)—Orchestra, European Symphony Orchestra 12
  - 3015 Fifth Symphony (Beethoven) (First Movement: Allegro con Brio, Part 1)—Orchestra, European Symphony Orchestra 12
  - Fifth Symphony (Beethoven) (First Movement: Allegro con Brio, Part 2)—Orchestra, European Symphony Orchestra 12
  - 3016 La Boheme (Puccini) (Selections—Part 1)—Orchestra ..... European Symphony Orchestra 12
  - La Boheme (Puccini) (Selections—Part 2)—Orchestra ..... European Symphony Orchestra 12

VOCAL RECORDS

- 4613 Time After Time (J. K. Brennan-E. R. Ball)—Tenor with Orch. .... Charles Hart 10
- That Tumble-Down Shack in Athlone (Pascoe-Carlo-Sanders)—Male Trio with Orch., Sterling Trio 10
- 4617 Complainin' (It's Human Nature to Complain) (A. Rogers-C. L. Roberts)—Contralto with Orch. .... Sophie Tucker 10
- Blue Bird, Where Are You? (G. Clarke-I. Maslof)—Contralto with Orch. .... Sophie Tucker 10
- 4620 A Dream (Charles B. Cory-J. C. Bartlett)—Tenor with Orch. .... Charles Hart 10
- The Kerry Dance (Molloy)—Tenor with Orch., Charles Hart 10
- 4621 My Wild Irish Rose (Chauncey Olcott)—Tenor with Orch. .... Gerald Griffin 10
- The Low Back'd Car (S. Lover)—Tenor with Orch. .... Gerald Griffin 10
- 4607 Some Sunny Day (Irving Berlin)—Contralto with Orch. .... Vaughn De Leath 10
- Alahamy Mammy (N. Fleeson-Albert Von Tilzer)—Contralto with Orch. .... Vaughn De Leath 10
- 4608 Mister Gallagher and Mister Shean (Ed. Gallagher-Al. Shean)—Tenor-Baritone Duet with Orch. .... Billy Jones-Ernest Hare 10
- She's Mine, All Mine! (Bert Kalmar-Harry Ruby)—Tenor with Orch. .... Billy Jones 10

DANCE RECORDS

- 4609 Boo Hoo Hoo (H. Link-I. Aaronson-Al Lentz)—Fox-trot ..... Joseph Samuels' Jazz Band 10
- The Village Clown (A. Countrycuss)—A Rural Fox-trot ..... Joseph Samuels' Jazz Band 10
- 4610 Black-Eyed Blues (Don Kendall)—Fox-trot, Markels' Orchestra 10
- Poor Little Me (Benny Davis)—Fox-trot, Rega Dance Orchestra 10
- 4605 California (Cliff Friend-Con Conrad)—Fox-trot, Vincent Lopez and His Hotel Pennsylvania Orch. 10
- Mo-Na-Lu (Louis Breaux)—Fox-trot, Vincent Lopez and His Hotel Pennsylvania Orch. 10
- 4606 Lovey Dove (From the Operetta, "The Rose of Stamboul") (Sigmund Romberg)—Fox-trot, Markels' Orchestra 10
- Romany Love (J. S. Zamecnik)—Fox-trot, Markels' Orchestra 10
- 4616 No Use Crying (If Your Sweetheart Goes Away) (Hugo Hirsch)—Fox-trot, Rega Dance Orchestra 10
- Do It Again (From "The French Doll") (George Gershwin)—Fox-trot ..... Markels' Orchestra 10
- 4612 Some Sunny Day (Irving Berlin)—Fox-trot, Vincent Lopez and His Hotel Pennsylvania Orch. 10
- Stumbling (Zez Confrey)—Fox-trot, Vincent Lopez and His Hotel Pennsylvania Orch. 10
- 4614 All Over You (Jerry Sullivan)—Fox-trot, Markels' Orchestra 10
- Suez (F. Grofe-P. DeRose)—Oriental Fox-trot, Markels' Orchestra 10
- 4615 Swanee Bluebird (Cliff Friend-Con Conrad)—Bird Voices by Sihyl Sanderson Fagan—Fox-

- trot ..... Rega Dance Orchestra 10
- Cairo Moon (Sid Caine-Sam Gold)—Fox-trot, Markels' Orchestra 10
- 4611 You Won't Be Sorry (E. Burnnett-L. Marcasia)—Fox-trot ..... Rega Dance Orchestra 10
- On the Alamo (Isham Jones)—Fox-trot, Rega Dance Orchestra 10

JUBILEE

- 4619 Going Up to Live with God ("Golden Slipper")—Colored Male Quartet ..... Excelsior Quartet 10
- Walk in Jerusalem Just Like John—Colored Male Quartet ..... Excelsior Quartet 10

BAND

- 4618 The King Clown (Irish Reel) (Intro. "Golden Slipper," "Hornpipe," "Bummer's Reel," "Irish Reel")—Band (Lieut. Joseph Kiefer, Bandmaster) ..... Philadelphia Police Band -10
- Up the Street March (R. G. Morse)—Band (Lieut. Joseph Kiefer, Bandmaster), Philadelphia Police Band 10

PATHE FRERES PHONOGRAPH CO.

(ACTUELLE RECORDS) STANDARD VOCAL

- 020757 The Bells of the Sea ..... Wilfred Glenn 10
- In a Little Town Near By ..... William Simmons 10
- 020758 Medley of Old Time Songs—Part III—(1) After the Ball, (2) Little Alabama Coon, (3) She Was Bred in Old Kentucky, (4) Put on Your Old Grey Bonnet ..... Orpheus Trio 10
- Medley of Old Time Songs—Part IV—In the Shade of the Old Apple Tree, (2) Break the News to Mother, (3) Wait Till the Sun Shines, Nellie, (4) There'll Be a Hot Time in the Old Town To-Night ..... Orpheus Trio 10
- 020759 Ilis Lullaby ..... Robert Bruce 10
- A Little Coon's Prayer ..... George Anderson 10

INSTRUMENTAL

- 020760 The Rosary (Violins and Piano) ..... Manhattan Trio 10
- Mighty Lak' a Rose (Violin and Piano), Manhattan Trio 10
- 20761 The Invincible Eagle—March, Empire State Military Band 10
- March Indienne—Hindu March, Empire State Military Band 10

HAWAIIAN

- 020762 Honolulu Honeymoon ..... Ferera-Franchini 10
- Hawaiian Nightingale ..... Ferera-Franchini 10

PATHE AND ACTUELLE RECORDS

DANCE RECORDS

- 20776 Coo-Coo—Fox-trot ..... Casino Dance Orchestra 10
- Nobody Lied—Fox-trot, N. Glantz and His Orchestra 10
- 20777 Suez—Fox-trot ..... Casino Dance Orchestra 10
- Romany Love—Fox-trot ..... Piedmont Dance Orchestra 10
- 20778 Haunting Eyes—Fox-trot ..... Synco Jazz Band 10
- It's Up to You (J'en Ai Marre)—Fox-trot, Piedmont Dance Orchestra 10
- 20779 Bamboo Bay—Fox-trot ..... Barth's Mississippi Six 10
- Those Blue-Eyed Blues—Fox-trot, Barth's Mississippi Six 10
- 20780 Are You Playing Fair—Fox-trot, Casino Dance Orchestra 10
- Parade of the Wooden Soldiers—Fox-trot, N. Glantz and His Orchestra 10
- 20781 'Neath the South Sea Moon—Fox-trot, Piedmont Dance Orchestra 10
- (From Ziegfeld Follies of 1922)
- List'nin' on Some Radio—Fox-trot, Piedmont Dance Orchestra 10
- (From Ziegfeld Follies of 1922)

POPULAR VOCAL

- 20782 My Yiddisha Mammy ..... Irving Kaufman 10
  - Rock Me in My Swanee Cradle ..... Vernon Dalhart 10
  - 20783 Kicky-Koo, You for Me; Me for You—Orpheus Trio 10
  - Why Should I Cry Over You ..... Ernest Hare 10
  - 20784 They Needed a Song Bird in Heaven..Robert Bruce 10
  - Whenever You're Lonesome (Just Telephone Me), Irving and Jack Kaufman 10
  - 20785 My Ramhler Rose ..... William Rundle 10
  - I Wish There Was a Wireless to Heaven, Elliott Shaw 10
- Records 20776 to 20785 may be obtained in both Pathé (sapphire) and Actuelle (needle-cut). Other numbers shown are Pathe numbers. The Actuelle number is the same as the Pathe but prefixed with a cipher, as 020723.

GENNETT LATERAL RECORDS

- 4677 Stumbling (Confrey)—Fox-trot, Hazey Natzy and His Orchestra 10
- Queen of the Orient (Cui) ..Lanin's Famous Players 10
- I-4878 A Santanotte (Buongiovanni) (Orch Acc.), E. Cucco 10
- 'O Viaggio E Nozze (Nicolò) (Orch Acc.) ..E. Cucco 10
- I-4879 L'America (Mario) (Orch. Acc.) ..... S. Romano 10
- Tanto Placere (Mario) (Orch. Acc.) ..... S. Romano 10
- I-4880 Canzone Marinaresca (Bossi) (Orch. Acc.), Della Monica 10
- Mandulinata A Napule (Tagliaferri) (Orch. Acc.) ..... Della Monica 10
- 4881 Jelly Roll Blues (Norfolk Jazz Quartette), Excelsior Quartette 10
- Kitchen Mechanic Blues (Excelsior Quartette), Excelsior Quartette 10
- 4882 Two Old Pals (Recitation) ..... Homer Rodeheaver 10
- Me an' Pap an' Mother (Recitation) (Strick Gillian) ..... Homer Rodeheaver 10
- 484 Schnitzelbank (Sticht) (Orch. Acc.), Heidelberg Quartette 10
- Im Grunewald Ist Holzauktion (Matthias) (Orch. Acc.) ..... Heidelberg Quartette 10
- S4885 La Cruz de Mayo (Canción Andaluza), Cantado por Amelia Rico 10
- Mi Homhre (Scottisch Español), Cantado por Luisa Rostand 10
- 4886 Hopeless Blues (Fox-trot) (Robinson-Turk), Ladd's Black Aces 10
- Lonesome Mama Blues (Fox-trot) (Brown), Ladd's Black Aces 10
- 4887 Kicky-Koo (You For Me—Me For You) (Fox-trot) (Lewis-Young-Meyer) ..Bailey's Lucky Seven 10
- Those Longing For You Blues (Fox-trot) (West-phal) ..... Bailey's Lucky Seven 10
- 4888 Swanee Bluebird (Fox-trot) (Conrad-Friend), Nathan Glantz and His Orchestra 10
- Romany Love (Fox-trot) (Zamenio), Nathan Glantz and His Orchestra 10
- 10061 I'll Sing Thee Songs of Araby (Wils-Clay), Henry Moeller 10
- Gypsy Love Song (Smith-Herbert)—From "The Fortune Teller"—Tenor ..... Henry Moeller 10
- 10062 Sorter Miss You (Smith) ..... Ruth Stickney 10
- Smilin' Through (Penn)—Tenor—Piano Acc. Thos. Griselle, ..... Henry Moeller 10
- Violin Ohhligato, Ruth Stickney 10
- 4889 In Maytime I Learned to Love (Snyder)—Waltz, Taylor Trio 10
- Smilin' Through (Penn)—Waltz—Introducing "Sorter Miss You"—Violin, Cello and Piano, Taylor Trio 10

LATEST PURITAN RECORDS

- 11135 Three o'Clock in the Morning—Waltz, Frisco Syncopators 10
- Swanee River Moon—Waltz ..... Frisco Syncopators 10
- 11134 Gray Morn—Fox-trot ..... Moulin Rouge Orchestra 10
- On the Alamo—Fox-trot ..... Moulin Rouge Orchestra 10
- 11133 Old Timer's Fox-trot (Introducing "Hello, My Baby," "Stay in Your Own Back Yard," "Bedelia," "I've Got Rings on My Fingers," "Yama Yama Man," "Hiawatha")—Compiled by Tom Eastwood ..... Frisco Syncopators 10
- O, Sing-a-loo—Fox-trot ..... Frisco Syncopators 10
- 11132 Rigoletto Quartette (Verdi)—Fox-trot—Arranged by Geo. Walters.Erdody and His Famous Orchestra 10
- Mighty Lak' a Rose (Nevin)—Fox-trot—Arranged by Geo. Walters, Erdody and His Famous Orchestra 10
- 11131 No Use Crying (If Your Sweetheart Goes Away)—Fox-trot ..... Majestic Dance Orchestra 10
- 11131 Kicky-Koo-Kicky-Koo (You for Me; Me for You)—Fox-trot ..... Majestic Dance Orchestra 10
- 11130 Song of Persia—Fox-trot ..... Eddie Davis Orchestra 10
- Sergeant Markel at the Piano 10
- Lovahle Eyes—Fox-trot ..... Eddie Davis Orchestra 10
- Sergeant Markel at the Piano 10
- 11129 Lonesome Mama Blues—Fox-trot, Original Memphis Five 10
- Those Longing For You Blues—Fox-trot, Original Memphis Five 10
- 11128 El Calendario Del Ano—Fox-trot—Escena de "Los Monaguillos" ..... Majestic Dance Orchestra 10
- Romany Love—Fox-trot ..... Eddie Davis Orchestra 10
- POPULAR VOCAL RECORDS
- 9115 Smilin' Through—Tenor Solo—Orch Acc..Sam Ash 10
- Oogie Oogie Wa Wa—Comedy Song—Orch. Acc. .... Billy West 10
- 9114 I Certainly Must Be in Love—Comedy Song—Orch. Acc. .... Billy West 10
- Oh! You Beautiful Baby—Comedy Song—Orch. Acc. .... Arthur Fields 10
- 9113 State Street Blues—Comedy Solo with Orch., Lucille Hegamin and Her Blue Flame Syncopators 10
- High Brown Blues—Comedy Solo with Orch., Lucille Hegamin and Her Blue Flame Syncopators 10
- STANDARD RECORD
- 15058 Step Lively—March ..... Pat Conway's Band 10
- The Whip—March ..... Pat Conway's Band 10
- 11120 Some Sunny Day—Fox-trot, Earl Randolph's Orchestra 10
- Stumhling—Fox-trot ..... Earl Randolph's Orchestra 10
- 11126 My Honey's Lovin' Arms—Fox-trot, Glantz and His Orchestra 10
- Samson and Delilah—Fox-trot, Majestic Dance Orchestra 10
- 11125 Gallagher and Shean—Fox-trot..Frisco Syncopators 10
- You Won't Be Sorry—Fox-trot, Majestic Dance Orchestra 10
- 11124 Teasin'—Fox-trot ..... Glantz and His Orchestra 10
- Bugle Call Blues—Fox-trot, Ford Dahneys' Syncopated Orchestra 10
- 11123 Honey Lou—Fox-trot (Vocal Chorus), Lenzberg's Riverside Orchestra 10
- Every Day—Fox-trot ..... Frisco Syncopators 10
- 11122 Doo Dah Blues—Fox-trot, Ford Dahney's Syncopated Orch. 10
- Sing Song Man—Fox-trot (Vocal Chorus), Lenzberg's Riverside Orchestra 10
- 11121 Sweet Man O'Mine—Fox-trot, Ford Dahney's Syncopated Orchestra 10
- Rosey Posey—Fox-trot ..... Frisco Syncopators 10
- 15056 Caro Nome—Coloratura Soprano ..... Josepha Dianno 10
- Queen of the Night—Coloratura Soprano, Josepha Dianno 10
- 15057 Carmen-Haherna—Soprano Solo ..... Maie Voland 10
- Heart Bowed Down—Baritone Solo.Guy Donaldson 10
- 11127 Rose of Stamboul—Tenor Solo..Charles Harrison 10
- Just a Little Love Song—Tenor Solo.Hugh Donovan 10
- 9110 O Sole Mio—Hawaiian Guitars, Ferera and Franchini 10
- Rio Nights—Hawaiian Guitars, Ferera and Franchini 10
- 9112 Medley of Old Time Songs—Part 1—Male Quartet ..... Stellar Quartet 10
- Medley of Old Time Songs—Part II—Male Quartet ..... Stellar Quartet 10
- 11119 Mister Gallagher and Mr. Shean—Song Duet, Kaufman Bros. 10
- Atta Baby—Comedy Song ..... Thomas-West 10
- 11118 Carolina Rolling Stone—Duet ..... Kaufman Bros. 10
- Swanee River Moon—Quartet ..... Stellar Quartet 10
- 11117 Little Gray Sweetheart of Mine—Fox-trot, California Ramblers 10
- Moon River—Waltz ..... California Ramblers 10
- 11116 California—Fox-trot ..... California Ramblers 10
- 11116 Pick Me Up and Lay Me Down—Fox-trot, Frisco Syncopators 10
- 11115 Georgia—Fox-trot (Vocal Chorus).Frisco Syncopators 10
- By-Gones—Fox-trot ..... California Ramblers 10
- 11114 Old-Fashioned Girl—Fox-trot, Vincent Lopez and His Hotel Penn. Orch. 10
- By the Sapphire Sea—Fox-trot, Vincent Lopez and His Hotel Penn. Orch. 10
- 11094 Sal-O-May—Fox-trot ..... Frisco Syncopators 10
- Three o'Clock in the Morning—Waltz, Newport Society Orchestra 10
- 9106 When You and I Were Young Maggie—Tenor Solo ..... Carl Williams 10
- Forgotten—Tenor Solo ..... Carl Williams 10
- 9105 Song Bird—Whistling Solo ..... Clara Young 10
- Souvenir—Violin Solo ..... Victor Provinsky 10
- 502 When Francis Dances With Me—Tenor Solo, Billy Jones 10
- Ten Little Fingers and Ten Little Toes—Vocal Duet ..... Ernest Hare and Billy Jones 10

BANNER RECORDS

DANCE RECORDS

- 1073 Gee, hut I Hate to Go Home Alone—Fox-trot, Majestic Saxophone Sextet 10
- Vocal Chorus, Arthur Hall 10
- Nohody Lied—Fox-trot...Majestic Saxophone Sextet 10
- Vocal Chorus, Arthur Hall 10
- 1074 Sweet Indiana Home—Fox-trot, Roy Collins' Orchestra 10
- El Calendario Del Ano—Fox-trot, Roy Collins' Orchestra 10
- 1075 Goo-Goo—Fox-trot ..... Majestic Dance Orchestra 10
- Lovahle Eyes—Fox-trot ..... Eddie Davis Orchestra 10
- 1076 J'En Ai Marro (It's Up to You)—Fox-trot, Roy Collins' Orchestra 10
- Do It Again—Fox-trot ..... Moulin Rouge Orchestra 10
- South Sea Moon (Follies 1922)—Fox-trot, Majestic Dance Orchestra 10
- 1062 Buzz Mirandy—Fox-trot ..... Original Memphis Five 10
- Deedle, Deedle, Du—Fox-trot.Original Memphis Five 10
- 1063 Colorado and You—Waltz.Metropolitan Music Masters 10
- Bahhling Brook—Waltz ..... Xylo Specialty Orchestra 10
- POPULAR VOCAL RECORDS
- 1078 Why Should I Cry Over You?—Tenor Solo—Orch Acc. .... Frank Spencer 10

(Continued on page 148)



ADVANCE RECORD BULLETINS FOR AUGUST—(Continued from page 147)

- Whenever You're Lonesome—Duet—Orch. Acc., Thomas-West  
 1079 Smilin' Through—Tenor Solo—Orch. Acc., Sam Ash  
 Annie Laurie—Contralto Solo—Orch. Acc., Nevada Van der Veer  
 1080 O'Reilly, I'm Ashamed of You—Tenor Solo—Orch. Acc., Billy Clarke  
 Oogie Oogie Wa Wa—Tenor Solo—Orch. Acc., Bert Trever  
 1061 Pick Me Up and Lay Me Down in Dear Old Dixieland—Tenor Solo—Orch. Acc., Bob White  
 California—Quartet—Orch. Acc., Stellar Male Quartet  
 1084 Little Red Schoolhouse—Duet—Orch. Acc., Thomas-West  
 I Wish There Was a Wireless to Heaven—Tenor Solo—Orch. Acc., Sam Ash
- COMEDY RECORD**  
 2045 Cohen Listens to the Radio—Comic Monolog, Monroe Silver  
 Cohen at the Movies—Comic Monolog, Monroe Silver
- VIOLIN RECORDS**  
 2046 Souvenir (Drdle)—Violin Solo—Piano Acc., Margaret Lorenzo  
 Valse Bluette (Drigo)—Violin Solo—Piano Acc., Margaret Lorenzo  
 2047 Viennese Popular Song—Violin Solo—Piano Acc., Margaret Lorenzo  
 Little Song (Deuxieme Cansonette) (A. d'Ambrosio)—Violin Solo—Piano Acc., Margaret Lorenzo
- HAWAIIAN RECORD**  
 2048 My Old Kentucky Home—Medley Hawaiian Guitars, Ferera-Franchini  
 Sweet Hawaiian Girl of Mine—Hawaiian Guitars, Ferera-Franchini
- PIANO SOLO**  
 2049 Kitten on the Keys—Piano Solo, Vi Palmer  
 Poor Buttermilk—Piano Solo, Vi Palmer

**REGAL RECORDS**

- DANCE RECORDS**  
 9320 South Sea Moon (Follies 1922)—Fox-trot, Glantz and His Orchestra  
 (J'En Ai Marre) (It's Up to You)—Fox-trot, Glantz and His Orchestra  
 9321 Lovable Eyes—Fox-trot, Eddie Davis Orchestra  
 El Calendario Del Ano—Fox-trot, Majestic Dance Orchestra  
 9322 Nobody Lied—Fox-trot, Stellar Saxophone Sextet  
 Gee, but I Hate to Go Home Alone—Fox-trot, Stellar Saxophone Sextet  
 Vocal Chorus, Arthur Hall  
 9323 Sweet Indiana Home—Fox-trot, Hollywood Dance Orchestra  
 Coo-Coo—Fox-trot, Hollywood Dance Orchestra  
 9324 Do It Again—Fox-trot, Regal Dance Orchestra  
 Cavalleria Rusticana—Fox-trot, Regal Dance Orchestra  
 9325 Deedle, Deedle, Dum—Fox-trot, Original Memphis Five
- POPULAR VOCAL RECORDS**  
 9326 Why Should I Cry Over You?—Tenor Solo—Orch. Acc., Arthur Hall  
 I Wish There Was a Wireless to Heaven—Tenor Solo—Orch. Acc., Sam Ash  
 9327 Little Red Schoolhouse—Duet—Orch. Acc., Thomas-West  
 Whenever You're Lonesome—Duet—Orch. Acc., Thomas-West  
 9329 Smilin' Through—Tenor Solo—Orch. Acc., Walter Scanlan  
 I Hear You Calling Me—Tenor Solo—Orch. Acc., Walter Scanlan
- COMEDY RECORD**  
 9328 Cohen Listens to the Radio—Comic Monolog, Monroe Silver  
 Cohen at the Movies—Comic Monolog, Monroe Silver
- STANDARD RECORDS**  
 9330 Irish Medley Waltz—Part 1, Regal Dance Orchestra  
 Irish Medley Waltz—Part 2, Regal Dance Orchestra  
 9331 Dreamy Hawaii—Hawaiian Guitars, Ferera-Franchini

- Hawaiian Twilight (Hawaiian Guitars), Ferera-Franchini  
 9332 The Mocking Bird—Whistling Solo, Margaret McKee  
 The Song Bird—Whistling Solo, Margaret McKee  
 9333 Medley of Country Reels—Violin Solo, Michael Donovan  
 Medley of Country Jigs—Violin Solo, Michael Donovan
- VIOLIN SOLOS**  
 9334 By the Brook, Margaret Lorenzo  
 Swing Song, Margaret Lorenzo  
 9335 Medifation From Thais, Milan Lusk  
 Humoresque, Milan Lusk

**BLACK SWAN RECORDS**

- POPULAR SONGS**  
 14115 Ain't Got Nothing Blues—Soprano, Mary Straine  
 Fowler Twist, John P. Vigal  
 (Bobbie Lee and His Imperial Six)  
 14116 Honey Rose, Mamie Jones  
 Mandy 'n' Me, Mamie Jones
- COMIC MONOLOG**  
 40002 The Dog, the Flea and the Bumble Bee, Archie Harrod  
 When Malindy Sings (Dunbar), Archie Harrod
- DANCE RECORDS**  
 10068 Zowie—Fox-trot, Fred Smith's Society Orchestra  
 10069 The Last Waltz, Henderson's Dance Orchestra  
 Jane—Fox-trot, Henderson's Dance Orchestra  
 10070 Spread Yo' Stuff—Fox-trot, Ethel Waters Jazz Masters  
 Snuggle—Fox-trot, Ethel Waters Jazz Masters
- INSTRUMENTAL**  
 60002 Southern Dixie Medley—Banjo, Joe Briggs  
 Yankee Jigs—Real Old Southern Fiddler, Tony Gray
- HAWAIIAN RECORDS**  
 25002 Dreamy Alabama, Kaluana & Brown  
 Drifting, Kaluana & Brown
- STANDARD VOCAL**  
 18047 Can't You Hear Me Calling, Caroline—Tenor, Harry A. Delmore  
 A Dream—Tenor, Harry A. Delmore
- SACRED RECORDS**  
 16057 Hallelu, Harrod's Jubilee Singers  
 Live Humble, Harrod's Jubilee Singers

**CORSON OPENS FINE STORE**

Music Merchant of Dalles, Ore., Handles Complete Line of Musical Instruments

DALLES, ORE., July 3.—One of the most attractive music stores in this section of the State is that of G. E. Corson, who recently opened a general music store in this city under the firm name of "Corson the Music Man." Mr. Corson is a firm believer in aggressive merchandising methods and the handling of the musical requirements of the people of his community with the aid of a representative stock. Among the instruments handled by him are pianos, player-pianos, stringed instruments of all kinds, sheet music and Brunswick phonographs and records.

A model example of unadulterated asininity is the fellow who sits in his store weeping salty tears because business is going to the dogs.

**TRADE PROGRESS DURING 1922**

Distinct Advances in Business Noted During First Half of Year, Says Dun's Review

The half-year just ended brought a distinct advance in business, with most of the gain in confidence and actual transactions achieved during the second quarter, says Dun's review of business conditions. Unsettled labor conditions in some industries have long been a detriment, curtailing operations and enhancing costs of production, and the railroad strike has greatly increased this uncertainty. Despite various drawbacks, however, recovery from previous depression has been substantial, if highly irregular, and many interests will be more active this Summer than was anticipated.

Interruptions from inventories and vacations will be experienced as usual, but there is clearly more work to be done this year and shutdowns will be less general and extended. A new and rather unexpected phase has arisen with the more frequent reports of labor scarcity in certain lines, the steel industry among them, and competitive bidding for workers is heard of in isolated instances. While there is still considerable idleness in different quarters more opportunity for employment is now afforded, and the public purchasing capacity would be measurably augmented if strikes were not present at coal mines and elsewhere. Such disputes invariably retard progress, though they may not wholly check it, and their effect on primary market prices is plainly visible in the existing situation.

**MUSICAL MUSEUM CHARTERED**

A provisional charter has been granted to the American Museum of Musical Art by the regents of the University of the State of New York. The museum will be located in Brooklyn, N. Y. The aims of the organization are to diffuse knowledge of the history and production of music; to preserve objects of interest relating to music and to maintain a building suitable for the service of the institution.

The Cammack Co., dealer in musical instruments, of St. Claire, Ill., has purchased a building in that village which it will occupy.

**You Ought to Know**

In case you are contemplating expanding the sphere of your business to include departments devoted to Pianos, Player-Pianos, Musical Merchandise or Sheet Music, that you'll find news and comments about them all in



The oldest and leading music trade weekly, which covers every branch of the industry

**It Contains**

*Instructive and educational articles. Hints on salesmanship and advertising. Editorials that are timely and authoritative. Facts about the new things in the trade. Trade happenings in all parts of the United States*

**"Review the Music Trade With Us"**

Send your \$2 now for a full year's subscription to

**THE MUSIC TRADE REVIEW**  
 373 FOURTH AVENUE  
 NEW YORK



# Some Leading Jobbers of Talking Machines in America

**TEST IT.**   
 OUR VICTOR  
**Record Service**  
 has a reputation for efficiency.  
 Suppose you try it.  
**E. F. DROOP & SONS CO.**  
 1300 G. STREET, WASHINGTON, D. C.  
 231 N. HOWARD STREET, BALTIMORE, MD

**W. J. DYER & BRO.**  
 DYER B'LD'G, ST. PAUL, MINN.  
 NORTHWESTERN DISTRIBUTORS  
 OF THE  
**VICTOR**  
 Machines, Records and Supplies  
  
 Shipped Promptly to all  
 Points in the Northwest

**Mickel Bros. Co.**  
 Omaha, Nebraska  
 Des Moines, Iowa  
**Victor Distributors**

  
**Where Dealers May Secure**  
**COLUMBIA**  
 Product  
 Ready, Full Stocks, and Prompt Deliveries  
 from Convenient Shipping Centers  
 all over the United States.  
**Distributors**  
 Atlanta, Ga., Columbia Graphophone Co., 561-563 Whitehall St.  
 Baltimore, Md., Columbia Graphophone Co., 16 South Howard St.  
 Boston, Columbia Graphophone Co., 1000 Washington St.  
 Buffalo, N. Y., Columbia Graphophone Co., 737 Main St.  
 Chicago, Ill., Columbia Graphophone Co., 325 W. Jackson Blvd.  
 Cincinnati, O., Columbia Graphophone Co., 317-321 East 8th Street.  
 Cleveland, O., Columbia Graphophone Co., 1812 East 30th St.  
 Dallas, Tex., Columbia Graphophone Co., 318 North Preston St.  
 Denver, Colo., Columbia Stores Co., 1608 Glenarm Ave.  
 Detroit, Mich., Columbia Graphophone Co., 115 State St.  
 Kansas City, Mo., Columbia Graphophone Co., 2006 Wyandotte St.  
 Los Angeles, Cal., Columbia Graphophone Co., 809 S. Los Angeles St.  
 Minneapolis, Minn., Columbia Graphophone Co., 18 N. 3rd St.  
 New Orleans, La., Columbia Graphophone Co., 517-525 Canal St.  
 New York City, Columbia Graphophone Co., 121 West 20th St.  
 Omaha, Neb., Columbia Graphophone Co., Eighth and Jackson Sts.  
 Philadelphia, Pa., Columbia Graphophone Co., 40 N. 6th St.  
 Pittsburgh, Columbia Graphophone Co., 632-640 Duquesne Way.  
 Salt Lake City, Utah, Columbia Stores Co., 221 South West Temple.  
 San Francisco, Cal., Columbia Graphophone Co., 345 Bryant St.  
 Seattle, Wash., Columbia Graphophone Co., 911 Western Ave.  
 Spokane, Wash., Columbia Stores Co., 161 South Post St.  
 St. Louis, Mo., Columbia Graphophone Co., 1127 Pine St.  
 Tampa, Fla., Tampa Hardware Co.  
 Headquarters for Canada:  
 Toronto, Ont., Columbia Graphophone Co., 347 West Adelaide St.  
 Montreal, Que., Columbia Graphophone Co., 824 St. Denis St.  
**Executive Office**  
**COLUMBIA GRAPHOPHONE CO.**  
 Gotham National Bank Building New York

**Sherman, Clay & Co.**  
 San Francisco, Los Angeles, Portland, Seattle, Spokane  
 PACIFIC COAST DISTRIBUTORS OF  
 VICTOR PRODUCTS

**SOUTHERN**  
**VICTOR WHOLESALERS**  
*The Corley Company*  
 RICHMOND VIRGINIA

The  
**Toledo Talking Machine Co.**  
 Toledo, Ohio  
**Wholesale Victor**  
**Exclusively**

## CONSTRUCTIVE ARTICLES IN THIS ISSUE OF THE WORLD

*Ready Reference for Salesmen, Dealers and Department Heads*

How a Live Saleswoman Created and Developed Talking Machine Business in Her Territory . . . . .	4	Germans Making Inroads Into Foreign Markets . . . . .	40
Records of Religious Numbers and Old-Time Ballads Have Big Sales Vogue . . . . .	6	A Striking Summer Display Window . . . . .	45
Value of Individualism in Advertising Unusual Efforts Bring Business Results . . . . .	8	Six Essentials in the Success of the Retail Store . . . . .	49
Prospects for the Future Are Decidedly Brighter . . . . .	8	Cost of Sales Decline Studied and Explained . . . . .	50
Helping Dealers to Elucidate Their Problems . . . . .	9	Buyers of Records Cannot Play Them for Profit . . . . .	51
Arranging Window Displays to Attract the Summer Buyer . . . . .	9	Aeolian Co.'s Annual Outing and Ball Game . . . . .	53
The Talking Machine as an Educator . . . . .	9	Propose Federal Control of Trade Associations . . . . .	60
The Importance of Manners and Their Relation to Effective Sales Work . . . . .	10	Denver Edison Dealers Form Association . . . . .	62
Some Window Display Ideas That Should Greatly Increase Record Trade . . . . .	12	Discussion of Radio Problems . . . . .	66
A Trend Toward Co-operative Advertising in Evidence Throughout the Country . . . . .	13	Review of Trade Conditions in New England Territory . . . . .	67-70
An Appealing Store Atmosphere Is Necessary for Business Development on a Sound Basis . . . . .	15	Why Tax on Knowledge Should Be Removed . . . . .	70
Records of Tribal Singers for Smithsonian Institute . . . . .	18	Featuring the Musical Possibilities of the Talking Machine . . . . .	74-75
A Thorough Knowledge of Operating Costs Essential to Business Success . . . . .	21-22	Trade Happenings in the Quaker City and Pennsylvania . . . . .	83-84
Determining Realized and Unrealized Profits on Instalment Sales . . . . .	24-26	Talking Machine Troubles and How to Remedy Them . . . . .	88
Four-minute Conferences on Business Topics . . . . .	27	Interesting Budget of News From the Dominion of Canada . . . . .	91
Letter of a Veteran Salesman to a Friend . . . . .	29	Mid-West Point of View and General Western Trade News . . . . .	94-105
Edward Fraser Carson's Monthly Talk . . . . .	32	"Chick" Evans' Golf Secrets Revealed Through Records . . . . .	104
Talking Machine Exhibits at Grand Rapids Furniture Show . . . . .	33	National Radio Show in Chicago a Great Success . . . . .	104
Phonographic Epigrammatics . . . . .	37	Gleanings From the World of Music . . . . .	115-117
It Is the Wide Appeal That Builds Business . . . . .	37	The Talking Machine Situation in Europe . . . . .	141-143
		Late Patents of Interest to the Talking Machine Trade . . . . .	144-145
		Advance List of August Bulletins of Talking Machine Records . . . . .	146-148



R C B Z A CO F H I KL N PQ S UA X VB D FG I YL N PQ S UV X ZV C EF H JK W OP R TA C EM O N  
**INDEX TO ADVERTISERS**  
 R PQ M KV H FE C VB C EF H CK W Od R TU W YL B DE G IX M JO Q ST VM Y AB D

**A**

Acme Die Casting Corp. .... 70  
 American Felt Co. .... 45  
 American Mica Works. .... 72  
 American Talking Machine Co. .... 80  
 Apex Recording Laboratories. .... 135  
 Atlantic Instrument Co. .... 50

**B**

Barnhart Bros. & Spindler. .... Inside back cover  
 Bell Hood Needle Co. .... 39  
 Bell Recording Co. .... 124  
 Blackman Talking Machine Co. .... 20  
 Blood Tone Arm Co. .... 105  
 Boston Book Co. .... 18  
 Brand, William .... 70  
 Bridgeport Die & Machine Co. .... 111  
 Brilliantone Steel Needle Co. .... 28  
 Bruno & Son, Inc., C. .... 71  
 Bruns & Sons, A. .... 26  
 Brunswick-Balke-Collender Co. Insert following page 18  
 Buegeleisen & Jacobson. .... 108

**C**

Cabinet & Accessories Co. .... 73, 120  
 Capitol Phonolier Corp. .... 131  
 Cheney Talking Machine Co. .... 58  
 Chicago Talking Machine Co. .... 93  
 Claremont Waste Mfg. Co. .... 110  
 Classified Want Ads. .... 139, 140  
 Columbia Graphophone Co. .... 16, 17, 34, 39, 42, 45, 50, 57, 78, 90, 106, 129, 134, 137  
 Consolidated Talking Machine Co. .... 52, 102  
 Corley Co. .... 149

**D**

De Forest Radio Telephone & Telegraph Co. .... 125  
 Diamond Products Co. .... 61  
 Diaphragm Co. .... 72  
 Ditson & Co., Chas. H. .... 67  
 Ditson Co., Oliver .... 67  
 Doctorow, D. R. .... 48  
 Dodge Mfg. Co. .... 63  
 Dodin, Andrew H. .... 145  
 Droop & Sons Co., E. F. .... 149  
 Duo-Tone Co. .... 32  
 Dyer & Co., W. J. .... 149

**E**

Eagle Radio Co. .... 88  
 Eastern Talking Machine Co. .... 69  
 Eclipse Musical Co. .... 132  
 Edison, Inc., Thos. A. .... 30, 31, Back cover  
 Eight Famous Victor Artists. .... 42  
 Emerson Phono Co. .... 133  
 Empire Phono. Parts Co. .... 12  
 Eshborn, Samuel .... 55

**F**

Feist, Leo .... 51, 55, 86, 92, 114, 116, 120, 126, 136  
 Fletcher-Wickes Co. .... 23  
 Flexlume Sign Co. .... 56  
 Fox Puh. Co., Sam. .... 116  
 Fulton T. M. Co. .... 122

**G**

General Phonograph Corp. .... Insert following page 34  
 General Phonograph Mfg. Co. .... 24  
 General Radio Corp. .... 127  
 Gihson-Snow Co. .... 47  
 Gramophone Co., Ltd. .... 141  
 Granby Phono. Corp. .... 22  
 Greater City Phono. Co. .... 13  
 Gretsch Mfg. Co., Fred. .... 86  
 Griffith Piano Co. .... 47

**H**

Hall Mfg. Co. .... 66  
 Harper & Bros. .... 74  
 Harponola Co. .... 19  
 Health Builders .... 89

Hessig-Ellis Drug Co. .... 47  
 Hough, J. E., Ltd. .... 143  
 Hough, L. W. .... 68

**I**

Isley, Doubleday & Co. .... 82  
 Iroquois Sales Co. .... 40  
 Italian Book Co. .... 33

**J**

Jenkins' Sons Co., J. W. .... 115  
 Jewel Phonoparts Co. .... 62, 95  
 Jewett Phono. Co. .... 41

**K**

Kent Co., F. C. .... 73  
 Kiefer-Stewart Co. .... 47  
 Kimball Co., W. W. .... 105  
 Knickerbocker T. M. Co. .... 10  
 Kraft, Bates & Spencer, Inc. .... 68

**L**

Lakeside Supply Co. .... 104  
 Lansing Sales Co. .... 70  
 Lauter Co., H. .... 78  
 Lee-Coit-Andreesen Hdw. Co. .... 47  
 Lidseen Products .... 57  
 Long Cabinet Co., Geo. A. .... 76  
 Long Island Phono. Co. .... 80  
 Lyradion Sales & Engg. Co. .... 63

**M**

Madison Music Co. .... 59  
 Magic Phono. Supply Co. .... 81  
 Magnavox Co. .... 38  
 Magnola T. M. Co. .... 97  
 Manhattan Recording Laboratories. .... 57  
 Manufacturers' Phono. Co. .... 79  
 Marshall Co., Inc., C. L. .... 47  
 McMenimen, H. N. .... 49  
 Mellor Co., C. C. .... 50  
 Melody National Sales Co. .... 103  
 Mermod & Co. .... 87  
 Mickel Bros. Co. .... 112  
 Minneapolis Drug Co. .... 47  
 Mittenhal, Inc., Jos. .... 117, 129, 134  
 Modernola Co. .... 60  
 Montagnes, I., & Co. .... 47  
 Moore-Bird & Co. .... 47  
 M. S. & E. .... 47  
 Mutual Phono. Parts Co. .... 35

**N**

National Deca.comania Co. .... 84  
 National Metals Depositing Corp. .... 124  
 National Publishing Co. .... 18  
 Netschert, Frank .... 88  
 New England Talking Machine Co. .... 69  
 New York Album & Card Co. .... 4  
 New York Talking Machine Co. .... 93  
 Nye & Co., Wm. F. .... 35

**O**

Ogden Sectional Cabinet Co., Inc. .... 21  
 Ormes, Inc. .... 9  
 Oro-Tone Co. .... 103  
 Orsenigo Co. .... 109  
 Osland, Inc. .... 129  
 Outing T. M. Co. .... 119

**P**

Pace Phono. Co. .... 117  
 Pathé Frères Phono. Co. .... 14  
 Peahody & Co., Henry W. .... 118  
 Pearsall Co., Silas E. .... 15  
 Peckham Mfg. Co. .... 45  
 Peerless Album Co. .... 11  
 Penn Phonograph Co. .... 83  
 Perfection Talking Machine Co. .... 137  
 Phillips Phono. Parts Co., Wm. .... 48  
 Phon-O-Game Co. .... 44  
 Phonomotor Co. .... 64

Phonotone Co. .... 84  
 Plaza Music Co. .... 27, 82  
 Pleasing Sound Phono. Co. .... 108  
 Plywood Corp. .... 33  
 Prima Radio Co. .... 113

**Q**

Qualitiphone Sales Co. .... 126

**R**

Raymond Engg. Co. .... 92  
 Regal Record Co. .... 49  
 Rene Manufacturing Co. .... 91  
 Repeat-A-Record Co. .... 75  
 Rex Gramophone Co. .... 142

**S**

Seaburg Mfg. Co. .... 37  
 Self-Lifting Piano Truck Co. .... 51  
 Shelton Elec. Co. .... 90  
 Sherburne Mfg. Co. .... 40  
 Sherman, Clay & Co. .... 6  
 Silent Motor Corp. .... 130  
 Simplex Elec. Phono. Motor Co. .... 36  
 Smith Drug Co., C. D. .... 47  
 Sonora Distr. Co. of Texas. .... 47  
 Sonora Co. of Philadelphia .... 47  
 Sonora Phonograph Co., Inc. Inside front cover, 46, 47, 87  
 Sonora Phonograph Co. of Pittsburgh. .... 47  
 Southern Drug Co. .... 47  
 Southern Sonora Co. .... 47  
 Southwestern Drug Co. .... 47  
 Sphinx Gramophone Motors .... 43  
 Sprague Radio Corp. .... 123  
 Starr Piano Co. .... 54  
 Steger & Sons Piano Mfg. Co. .... 65  
 Sterling Devices Co. .... 101  
 Sterno Manufacturing Co. .... 128  
 Strevell-Paterson Hardware Co. .... 47  
 Swanson Sales Co. .... 25

**T**

Talking Machine Supply Co. .... 139  
 Talking Machine World Trade Directory. .... 85  
 Templar Mfg. Co. .... 98  
 Toledo Talking Machine Co. .... 149

**U**

Udell Works .... 53  
 Unit Construction Co. .... 107  
 United Mfg. & Distr. Co. .... 96  
 United Music Stores .... 84  
 Universal Fixtures Co. .... 122  
 Unyversal Utylyty Unyts Co. .... 98

**V**

Val's Accessory House .... 55  
 Van Houten, C. J., & Zoon. .... 47  
 Van Veen & Co. .... 110  
 Vicsonia Mfg. Co. .... 114  
 Victor Talking Machine Co. .... Front cover, 5, 7

**W**

Walbert Mfg. Co. .... 99  
 Wall Kane Mfg. Co. .... 29  
 Waltham Music Co. .... 47  
 Weymanu & Son, H. A. .... 84  
 Whitsit Co., Perry B. .... 78  
 Widdicomb Furniture Co. .... 121  
 Williams Co., G. T. .... 81  
 Wimpfheimer & Bro., A. .... 34  
 Wolf Mfg. Industries. .... 100

**Y**

Yahr & Lange Drug Co. .... 47

**Z**

Zimmerman-Bitter Constr. Co. .... 77



# The NEW Scotford Tonearm and Superior Reproducer



*A new external shape of grace and beauty—without changing the internal design:*



That same angle turn with the solid inclined plane deflecting the sound waves straight downward into amplifying chamber. That same famous Scotford tone—the tone of refinement—genuinely musical. Now in a tonearm of accepted, conventional, popular design. WRITE FOR SAMPLES.



STYLE No. 1 FINISH  
A combination of Nickel or Gold Plate and Black Rubber Japan

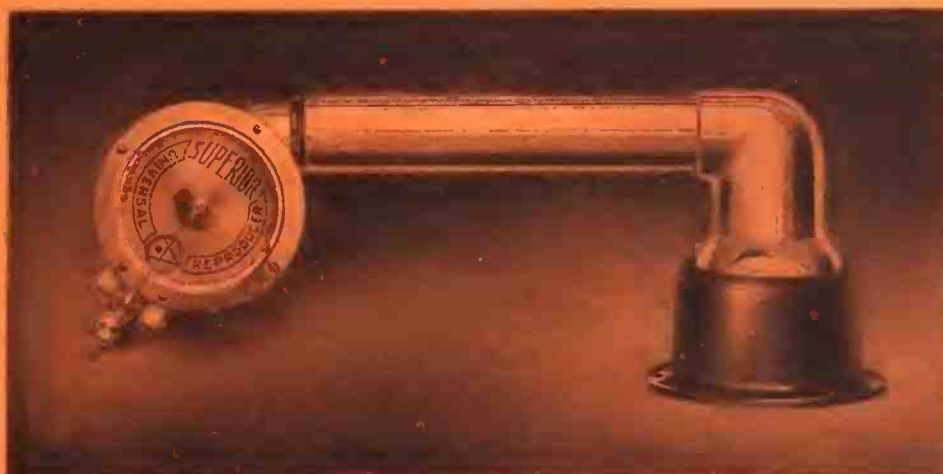

STYLE No. 2 FINISH  
A different combination of Nickel or Gold Plate and Black Rubber Japan



STYLE No. 3 FINISH  
All parts Plated in Nickel or Gold

*In ordering specify whether Reproducer should have Plain Gilt Plate or "Superior" Name Plate. To obtain Individual Name Plate, customer must furnish Decalcomania Transfer*

### Samples Will be Submitted on Approval

Style 1 Tonearm long tube and main elbow, Reproducer face ring and back Black Japanned; other parts Plated.  
Style 2 Tonearm long tube and main elbow Plated, base Black Japanned; Reproducer back Black Japanned, the face ring and frame Plated.  
Style 3 All parts of Tonearm and Reproducer are Plated.

No. 1 New Scotford Tonearm and Superior Reproducer . Nickel \$7.00 Gold \$ 9.00  
No. 2 New Scotford Tonearm and Superior Reproducer . Nickel 7.75 Gold 10.00  
No. 3 New Scotford Tonearm and Superior Reproducer . Nickel 8.50 Gold 11.00

*Samples Prepaid at the Above Prices*

*Write for Our  
Specification Sheet and Quantity Price List*

## BARNHART BROTHERS & SPINDLER

Monroe and Throop Streets

CHICAGO, ILLINOIS

### NEW CONSTRUCTION



The long straight tube is of drawn Yellow Brass. Tonearm Base, Main Elbow and Connection Elbow and the Reproducer Frame, Face Ring and Back Plate are cast of TENSO White Brass Alloy—an alloy more than double the tensile strength of cast iron—much stronger, harder and lighter in weight than ordinary white metal alloys. New dies have been produced for casting all parts. The new parts are solidly cast, and are very substantial and durable.



**N**O PHONOGRAPH, even though it be Mr. Edison's latest achievement, can be quite complete, just as no rare gem can be quite perfect until a setting is produced that is worthy of it.



The settings of four New Edison Consoles in period designs are displayed on pages 30, 31.



THOMAS A. EDISON, Inc.  
ORANGE, NEW JERSEY

JOBBER OF THE NEW EDISON, EDISON RE-CREATIONS, THE NEW EDISON DIAMOND AMBEROLA AND BLUE AMBEROL RECORDS

**CALIFORNIA**  
Los Angeles—Edison Phonographs, Ltd.  
San Francisco—Edison Phonographs, Ltd.  
**COLORADO**  
Denver—Denver Dry Goods Co.  
**GEORGIA**  
Atlanta—Phonographs Inc.  
**ILLINOIS**  
Chicago—The Phonograph Co. Wm. H. Lyons (Amberola only).  
**INDIANA**  
Indianapolis—Kipp Phonograph Co.  
**IOWA**  
Des Moines—Harger & Blish.  
**LOUISIANA**  
New Orleans—Diamond Music Co., Inc.

**MASSACHUSETTS**  
Boston—Pardee-Ellenberger Co.  
Iver Johnson Sporting Goods Co. (Amberola only).  
**MICHIGAN**  
Detroit—Phonograph Co. of Detroit  
**MINNESOTA**  
Minneapolis—Laurence H. Lucker  
**MISSOURI**  
Kansas City—The Phonograph Co. of Kansas City.  
St. Louis—Silverstone Music Co.  
**MONTANA**  
Helena—Montana Phonograph Co.  
**NEBRASKA**  
Omaha—Shultz Bros.

**NEW JERSEY**  
Orange—The Phonograph Corp. of Manhattan.  
**NEW YORK**  
Albany—American Phonograph Co.  
Syracuse—Frank E. Bolway & Son, Inc., W. D. Andrews Co. (Amberola only).  
**OHIO**  
Cincinnati—The Phonograph Co.  
Cleveland—The Phonograph Co.  
**OREGON**  
Portland—Edison Phonographs, Ltd.  
**PENNSYLVANIA**  
Philadelphia—Girard Phonograph Co.  
Pittsburgh—Buehn Phonograph Co.  
Williamsport—W. A. Myers.  
**RHODE ISLAND**  
Providence—J. A. Foster Co. (Amberola only).

**TEXAS**  
Dallas—Texas-Oklahoma Phonograph Co.  
**UTAH**  
Ogden—Proudfit Sporting Goods Co.  
**VIRGINIA**  
Richmond—The C. B. Haynes Co., Inc.  
**WISCONSIN**  
Milwaukee—The Phonograph Co. of Milwaukee.  
**CANADA**  
Montreal—R. S. Williams & Sons Co., Ltd.  
St. John—W. H. Thorne & Co., Ltd.  
Toronto—R. S. Williams & Sons Co., Ltd.  
Vancouver—Kent Piano Co., Ltd.  
Winnipeg—R. S. Williams & Sons Co., Ltd.  
Bahson Bros. (Amberola only).