

The TALKING MACHINE WORLD

For the
makers &
sellers of
talking
machines

Published Each Month by Edward Lyman Bill, Inc., at 373 Fourth Ave., New York, November 15, 1921

Victrola

REG. U. S. PAT. OFF.

The word "Victrola" as well as the picture "His Master's Voice" is an exclusive trademark of the Victor Talking Machine Company. Being registered trademarks they cannot lawfully be applied to other than Victor products.



"HIS MASTER'S VOICE"

REG. U. S. PAT. OFF.

Victor Talking Machine Company, Camden, N. J.

The Phonograph That Sells Itself

HERE is no phonograph that sells itself to discriminating buyers so easily as Sonora.

There is no quality phonograph that will show you more real profit than a Sonora.

Why invest your money, time and energy pushing an unknown or unpopular make when the golden road to big profits, business permanency and stability is paved with Sonoras?

Sonora dealers make a most satisfactory margin of profit on each Sonora sale.

The prestige of selling the Highest Class Talking Machine in the World, the Sonora improvements and advantages which enable dealers to meet any competition, the superior quality so apparent when making a comparison with others, and the substantial trade discounts, are the reasons why Sonora dealers take out big profits from their business regularly.

THE INSTRUMENT OF QUALITY
Sonora
CLEAR AS A BELL



The Highest Class Talking Machine in the World

Sonora Phonograph Company, Inc.

GEORGE E. BRIGHTSON, President

New York: 279 Broadway

Canadian Distributors
I. MONTAGNES & CO., TORONTO

NOTE—Sonora is licensed and operates under BASIC PATENTS of the phonograph industry

The Talking Machine World

Vol. 17. No. 11

New York, November 15, 1921

Price Twenty-five Cents

VICTOR SALESPEOPLE ORGANIZE

Members of Various Red Seal Classes Effect Permanent Organization for the Dissemination of Information of Interest and Value

As a direct result of the spirit of camaraderie and co-operation, built up between the members of the various classes that have been held at the Salesmanship School at the Victor factory, there has been effected a permanent organization of Victor salespeople with a view to realizing permanent benefits from the valuable instruction they received and the associations enjoyed during their school term.

Each of the twenty-seven classes that have so far enjoyed the privilege of attending the Victor school has appointed a secretary, selected a special name to distinguish it, such as the "Red Seal Library Builders," the "Johnson Class," the "Pacemakers," etc., has selected a suitable motto and has arranged, through the secretary, to interchange selling ideas to the advantage of all concerned.

According to the plan as outlined the members of the various classes, when they come upon a new selling idea that works out successfully, will present that idea to the secretary, who will, in turn, see that it is spread about among the members of that particular class and also through

the other classes. It is believed that such assistance will result in incalculable good.

FURNISHES RECORDS ON CONTRACT

Insures Latest Selections for Customer and Rapid Stock Turnover for Store

Furnishing talking machine records on contract is the plan in use in the talking machine department of Frederick Loeser & Co.'s big store on Fulton street, Brooklyn, N. Y. When a talking machine is sold an effort is made by the salesman to sell the customer the idea of contracting to take a stipulated number of records. These records are delivered a few at a time, thus making certain that the customer will receive the latest selections as soon as they are released to the public and at the same time insuring a rapid stock turnover.

MME. VICARINO OLYMPIC ARTIST

The Olympic Disc Record Corp., New York City, announces the addition to its list of artists of Mme. Regina Vicarino, coloratura soprano, now starring in "The Impresario," in which Percy Hemus, exclusive Olympic artist, is the leading man. The first records of Mme. Vicarino appeared in the November Olympic releases.

MOTORCYCLE HELPS IN DELIVERIES

Makes for Speed and Economy in the Filling of Certain Types of Small Orders

A Western talking machine dealer, in a fairly large city and with a considerable rural territory to cover, has found a way to cut down his delivery expenses materially through the use of a motorcycle equipped with a side-car. The side-car is so built that it will hold a very substantial number of records and can also carry a table model, or a small cabinet model machine. Particularly for carrying records and for collecting motors, etc., for repairs, the motorcycle idea has proved a most economical one.

This particular dealer keeps in service a large motor delivery wagon, which is used for all general hauling purposes, for bringing goods from the freight station and for delivering machines and records to retail purchasers. For reasons of economy the attempt is made to lay out a more or less regular schedule for the wagon, in order to make as many deliveries and cover as much ground as possible during the course of the day.

It is often found, in cases where several deliveries are to be made in one section of the city and probably only a half dozen records to be delivered in another section several miles away, that for the truck to make this extra trip means extra time and expense. But by the use of the motorcycle the store porter can be sent out with a small delivery without interfering in any great degree with his regular duties. The motor car service has also made it possible for the dealer to advertise a special "within the hour" delivery service on telephone record orders when desired. It makes an excellent talking point, even though the majority of record purchasers prefer to select their records in person and have them delivered later.

Even at times when the large delivery wagon is available for use it has been found much more economical to use the motorcycle for delivering small packages of records, the saving in time and gasoline being quite considerable.

HELPS TO PROTECT EXPORT TRADE

Government Taking Steps to Protect Interests of Exporters of Musical Instruments

WASHINGTON, D. C., November 5.—The interests abroad of exporters of musical instruments will be protected and furthered by the Government through the Department of Commerce, according to plans which have just been completed by Secretary Hoover. Included in the dozen commodity divisions which are being formed in the Bureau of Foreign and Domestic Commerce is a Specialties Division, under which will come musical instruments and other articles not of themselves of sufficient importance in our total trade to warrant a separate division.

Carl H. Greene, of New York, has been appointed by the Secretary as chief of this new division. Mr. Greene has had many years' experience in export work, having been secretary of the Export Managers' Club, of New York, and formerly connected with the National Association of Manufacturers.

While not of sufficient importance to necessitate a separate classification, musical instrument markets abroad are very large and quite promising, officials of the department say, and every effort will be made to give the manufacturers and exporters in this country all available information which can be secured by the department's foreign agents regarding the activities of foreign manufacturers, opportunities for making new foreign connections, the opening up of new markets and new demands, etc.

Charles H. Mackintosh says that stopping advertising because business is poor is like cutting off the gas on a grade.

WHERE THE TALKING MACHINE DOES THE LECTURING

D. G. Baird Tells World Readers How the Detroit Traffic Department Is Using This Marvelous Invention to Prevent Accidents and Regulate Traffic—What Other Towns May Do

More and more the talking machine is coming to be recognized as a necessity. Not only is the home incomplete without this marvelous invention, but corporations, merchants, lecturers and others are rapidly adopting it in their business. As an example of the good that the talking machine may do and of the labor and money it may be made to save, the experience of the Accident-prevention Bureau of the Detroit Traffic Department may be cited.

What is said to be the largest talking machine in the world is now being employed by this bureau in its campaign to reduce the number of traffic accidents in the city. The machine is really a portable one of standard make, connected to an amplifier which is housed in a huge box made to represent the cabinet of a talking machine. This box is an exact duplicate of the cabinet phonograph and measures six feet square by eight feet in height. When in operation the sounds proceed from the front of the box and the hearers are persuaded that it is actually an enormous talking machine.

On the side of the box, in large white letters, is the declaration: "More destructive than siege guns! More deadly than war! Carelessness." The machine is transported from place to place on a Ford car and plays and talks as it goes. Arrived at an auditorium or other place of assembly where it is to be used for a lecture on safety first, it is set up on the stage, or simply left on the car. A thirty-minute musical program is then given, followed by a special record which gives facts and figures on traffic accidents; with advice for reducing their number.

The device was conceived and is operated by H. O. Rounds, of the Accident-prevention Bureau, and has enabled him to dispense with the services of a quartet and other musicians whom he formerly employed to entertain the crowds, as well as to save his own throat of much lecturing.

Mr. Rounds is continually on the go, giving his sugar-coated advice at public parks, in schools, at fairs and other places where large crowds are wont to gather. He estimates that he has reached 600,000 people with his message during the recent Summer. Detroit accidents have been cut in half since this campaign started.

Mr. Rounds conceived the idea of letting a talking machine do his lecturing as a result of having his curiosity piqued by hearing the music of a band that he could not locate. He at last learned from a policeman that the "band" was



nothing more than a talking machine to which an enterprising dealer had connected an amplifier. He at once concluded that such a device would be an excellent asset to him in his campaign, and after much persuasion succeeded in prevailing upon his superiors to have the instrument constructed.

The accompanying illustration shows the machine set up at the Michigan State Fair, held in Detroit in September.

Such a device could be used to advantage by any talking machine dealer. It could be placed in the show window or in the front of the store near an open door and would be sure to attract much attention, whether or not it was kept playing. Any carpenter or cabinet maker would construct the cabinet for a small sum. The amplifier is not very expensive and the cabinet would not necessarily be made of costly wood.

What Are You Doing to Make the Yuletide One of Your Greatest Selling Periods

By
L. A. Case

Just consider, Mr. Talking Machine Dealer, that within five weeks Christmas will be with us—a time when the talking machine is one of the essentials to the enjoyment of that festive period. What are you doing toward making the holidays one of the greatest selling periods in the history of your business? It is to be taken for granted that you are well prepared in regard to stock—if you are not you have only your own carelessness or timidity to blame.

Now, what steps are you taking to get rid of that stock before January 1? It is the time to prepare a definite plan of campaign—a time to get really busy, a time to accomplish things.

Several dealers whom we know have ransacked the catalogs for records suitable for the holiday period, both sacred and secular. These records have been listed in pamphlet form and by adding a few pages space has been found to illustrate and describe the latest models of machines, the new attachments and, incidentally, a very interesting talk regarding that store's ability to serve its clientele. The cover is appropriately ornamented with a design of holly leaves and the booklet will be mailed to a selected list of customers and prospects on December 5, reaching them at a time when they should be interested in the question of Christmas gifts.

These dealers have also prepared a follow-up letter urging recipients to get busy on their Christmas gifts and again pointing out wherein the talking machine records constitute some of the most practical and best-remembered gifts for the holidays. This is practical, constructive work which is well worth emulating.

Another dealer has had prepared a series of live advertisements, headed "Talks to Holiday Buyers," which he has already begun to run in the local dailies, one appearing each day in consecutive order. These special advertisements will appear right up to Christmas and tell one continuous story with each part complete in itself. This dealer tried the same plan last year and found it wonderfully successful and, with the many new attachments, etc., offered this season, looks for still greater returns during the present year.

Appealing directly to the musical sense of the public through the medium of free concerts is the scheme of a New England dealer. His store

is on the main business thoroughfare of the town and crowds of shoppers are continually passing the door. The adjoining store has been empty for several months, owing to the assignment of the former occupants, and, pending the occupancy by new tenants on January 1, Mr. Dealer has rented the premises for the month of December. He has arranged to hire 250 camp stools, and, being an agent for a home moving-picture machine in addition to handling talking machines, he has arranged for nightly entertainments during the month that will un-

dealer's line and suitable holiday presents that can be chosen from it.

Yet another dealer has conceived the unique plan of sending out postal cards bearing a return portion. A cordial invitation is extended to the recipient to visit the store and listen to the latest records, particularly those suitable for the holidays, and examine the machines. On one side of the card the prices of the various styles of machines are printed. Those who cannot or do not care to visit the store are requested to mark the style of machine the price of which suits them, and upon the return of the postal the dealer sends an assistant to the house with a sample of the machine indicated and a liberal supply of late records. In two weeks in December, last year, the dealer sold machines to seventeen of twenty-two prospects before whom the machines were demonstrated in their homes.

These are only a few of the schemes that have been, or are to be, adopted by as many dealers. There are many more that could profitably be adopted by other dealers. Try to be original, for it is a feature that will win success for even a really weak proposition. Work out an idea that is new to your town and drive it home. With over a month to get holiday business in every dealer should plan to get, and succeed in getting, his full share. The idea of the turtle being slow but "getting there just the same" doesn't hold in business to-day; it's the rabbit, who gets away jumping and ends up with a rush, who gets the backing and wins the money. Don't be the turtle.

Work Out an Idea in Your Territory That Is Really New and Drive It Home During the Holiday Period

doubtedly mean business. The latest films will be shown and suitable music rendered through the medium of the "talkers." Attractive programs will bear, besides the list of views and musical selections, an extended description of the

MUSIC AS AN AID TO WORKERS

Talking Machines Being Installed in Manufacturing Plants to Entertain and Stimulate Workers—Most Effective in This Field

A great many manufacturing plants have installed talking machines not only for the entertainment of employees during luncheon hour, but also as a means of stimulating the men during working hours. Employers have found, after a very careful examination, that through the use of the talking machine there has been an increased labor output of from 10 to 15 per cent. Whether this is due entirely to the "talker" or the willingness of the men to render greater value in

the way of work than was heretofore the case is a question. Suffice it that the talking machine is filling the dual rôle of affording pleasure and of enabling the men to do work, and more of it, in pleasing environment. One of the latest concerns to test the value of the talking machine is a large printing plant in Chicago, where, despite all the noise and apparent confusion necessary to the production of publications, it was found that hands moved more quickly over the cases and feeders fed the presses faster when the record of a stirring, lively piece of music was on the machine. All this goes to show that music, particularly through the medium of the talking machine, is a necessity in the factory as it is in the home.

THESE ARE SOME OF THE REASONS FOR OUR EXCEEDINGLY LOW PRICES

THE TALKING MACHINE'S HELPMATE



Our latest improved albums are meeting with remarkable success in the trade. Increased manufacturing facilities and improved machinery have enabled us to enlarge our output and consequently realize great savings in raw material cost due to quantity buying.

We make sets to equip every style of machine. Our special set, with complete set of shelves for No. 80 Victrola, as illustrated, consists of more albums than any other album set on the market to-day and gives the dealer the opportunity to sell more records. Yet the price of the new NYACCO set is no more than the price of ordinary old-style album sets.

Shipments can be made F. O. B. New York or Chicago, as you may desire, thereby saving you freight or expressage.

We guaranty our NYACCO albums as to quality, construction and expeditious deliveries.

**Don't wait for the rush season to place your orders!
Order now for fall and winter delivery.**

Jobbers and Distributors throughout the United States and Canada

Write for Quotations. Samples submitted upon request

New York Album & Card Co., Inc.

NEW YORK
23-25 Lispenard Street

CHICAGO
415-417 S. Jefferson Street

A. W. CHAMBERLAIN, New England Factory Representative, 26 Broad St., Boston, Mass.

Victor Supremacy

Supreme as a musical instrument, the Victrola naturally stands supreme as a business proposition.

The success of Victor retailers follows Victor supremacy as a matter of course.

"Victrola" is the Registered Trade-mark of the Victor Talking Machine Company designating the products of this Company only.

Warning: The use of the word **Victrola** upon or in the promotion or sale of any other Talking Machine or Phonograph products is misleading and illegal.

Important Notice. Victor Records and Victor Machines are scientifically co-ordinated and synchronized in the processes of manufacture, and should be used together to secure a perfect reproduction.

Victor Wholesalers

Albany, N. Y. Gately-Haire Co., Inc.
 Atlanta, Ga. Elyea Talking Machine Co.
 Phillips & Crew Piano Co.
 Baltimore, Md. Cohen & Hughes
 E. F. Droop & Sons Co.
 H. R. Eisenbrandt Sons, Inc.
 Birmingham, Ala. Talking Machine Co.
 Boston, Mass. Oliver Ditson Co.
 The Eastern Talking Machine Co.
 The M. Steinert & Sons Co.
 Brooklyn, N. Y. American Talking Mach. Co.
 G. T. Williams Co., Inc.
 Buffalo, N. Y. Curtis N. Andrews
 Buffalo Talking Machine Co., Inc.
 Burlington, Vt. American Phonograph Co.
 Butte, Mont. Orton Bros.
 Chicago, Ill. Lyon & Healy.
 The Rudolph Wurlitzer Co.
 Chicago Talking Machine Co.
 Cincinnati, O. Ohio Talking Machine Co.
 The Rudolph Wurlitzer Co.
 Cleveland, O. The Cleveland Talking Machine Co.
 The Eclipse Musical Co.
 Columbus, O. The Perry B. Whitsit Co.
 Dallas, Tex. Sanger Bros.
 Denver, Colo. The Knight-Campbell Music Co.
 Des Moines, Ia. Mickel Bros. Co.
 Detroit, Mich. Grinnell Bros.
 Elmira, N. Y. Elmira Arms Co.
 El Paso, Tex. W. G. Walz Co.
 Honolulu, T. H. Bergstrom Music Co., Ltd.
 Houston, Tex. The Talking Machine Co. of Texas.
 Indianapolis, Ind. Stewart Talking Machine Co.
 Jacksonville, Fla. Florida Talking Machine Co.
 Kansas City, Mo. I. W. Jenkins Sons Music Co.
 The Schmelzer Co.
 Los Angeles, Cal. Sherman, Clay & Co.
 Memphis, Tenn. O. K. Houck Piano Co.

Milwaukee, Wis. Badger Talking Machine Co.
 Minneapolis, Minn. Beckwith, O'Neill Co.
 Mobile, Ala. Wm. H. Reynolds
 Newark, N. J. Collings & Co.
 New Haven, Conn. The Horton-Gallo-Creamer Co.
 New Orleans, La. Philip Werlein, Ltd.
 New York, N. Y. Blackman Talking Mach. Co.
 Emanuel Blout.
 C. Bruno & Son, Inc.
 Charles H. Ditson & Co.
 Knickerbocker Talking Machine Co., Inc.
 Musical Instrument Sales Co.
 New York Talking Mach. Co.
 Ormes, Inc.
 Silas E. Pearsall Co.
 Omaha, Nebr. Ross P. Curtice Co.
 Mickel Bros. Co.
 Peoria, Ill. Putnam-Page Co., Inc.
 Philadelphia, Pa. Louis Buehn Co., Inc.
 C. J. Heppe & Son.
 The George D. Ornstein Co.
 Penn Phonograph Co., Inc.
 The Talking Machine Co.
 H. A. Weymann & Son, Inc.
 Pittsburgh, Pa. W. F. Frederick Piano Co.
 C. C. Mellor Co., Ltd.
 Standard Talking Mach. Co.
 Portland, Me. Cressey & Allen, Inc.
 Portland, Ore. Sherman, Clay & Co.
 Richmond, Va. The Corley Co., Inc.
 Rochester, N. Y. E. J. Chapman.
 Salt Lake City, U. The John Elliott Clark Co.
 San Francisco, Cal. Sherman, Clay & Co.
 Seattle, Wash. Sherman, Clay & Co.
 Spokane, Wash. Sherman, Clay & Co.
 St. Louis, Mo. Koerber-Brenner Music Co.
 St. Paul, Minn. W. J. Dyer & Bro.
 Syracuse, N. Y. W. D. Andrews Co.
 Toledo, O. The Toledo Talking Machine Co.
 Washington, D. C. Cohen & Hughes
 E. F. Droop & Sons Co.
 Rogers & Fischer



Victrola VI, \$35
Mahogany or oak



Victrola IX, \$75
Mahogany or oak



Victrola No. 80, \$100
Mahogany, oak or walnut



Victrola No. 120, \$275
Victrola No. 120, electric, \$337.50
Mahogany or oak

Victor Talking Machine Co.

Camden, N. J., U. S. A.



The Importance of Knowing Human Nature in the Selling of Talking Machines

By
S. C. McGregor

The successful talking machine salesman must have a thorough knowledge of the product he sells. To secure a permanent trade he must have faith in what he sells, and the ability to talk convincingly is another asset. But of what value are these if the greatest possibility of increasing sales is overlooked?

There are many failures in the talking machine industry due directly to neglecting this possibility—that of knowing human nature. Take a dozen of the many factors that successful men say were the foundations of their success, and you will find that behind all the other contributory factors was the fundamental one of knowing human nature. For of what value is a good sales talk if you do not know how to apply it to the particular needs of the customer before you?

Talking machine salesfolk have one outstanding fault: They fail to size up the customer, and treat everybody the same, as though they were as mechanical as the reproducing apparatus the prospective customer is interested in.

And this seems the more remarkable when we consider the music buyers embrace every type of humanity. Indeed, with the possible exception of the newspaper correspondent, the talking machine salesman has the finest opportunity to study human nature.

Perhaps you think, "Oh, what's the use?" If you really want to be a success you will do well to study the people who come into your shop, for successful attainment is coming to mean helping humanity, and your task is much easier if you know something of the emotions of the person you are trying to help.

No two persons are alike, but there are

"types," groups of persons who are interested in a particular phase of music, such as the classical enthusiast, the violin specialist, or those who want snappy dance music. Everybody has musical preferences, and in too many cases the salesman tries to force his own on the customer, or else lends undue emphasis to the merits of overstocked goods, when something else would do the customer more good.

If you are making a sincere effort to know human nature, and are discouraged at slow

A Good Sales Talk Is of Little Value if the Salesman Cannot Apply It to the Particular Needs of the Customer

progress, remember this: human nature is the broadest subject there is, and those who know the emotions of their fellow men fought through greater difficulties than those you are facing, for you have advantages they didn't have. And keep on studying human nature!

There are no fixed methods of study for those who would know more about life. Patience, trying to imagine yourself in the other fellow's

place—these are two phases of the art of pulling heartstrings, for that is what lies within the power of those who know human nature. Some do it with music, others with paintings, or stories, or books.

Music invariably stirs the emotions, and if you are observing you will gradually become able to anticipate the wants of the prospective customer. That is worth while, for the customer may ask for "any good music." If you can suggest something that appeals to him, then you have made a good impression, and for that reason are more apt to get his future trade. Then, too, you may be able to suggest music that the customer would like but that he has never heard, for a great many music buyers are not familiar with the names in the catalogs.

URNS DOOR INTO SHOW WINDOW

Cleveland Merchant Gives Idea for Talking Machine Men With Small Display Space

The new answer to the ancient riddle is that a door is not a door when it is a show window. Every bit of display space counts, and a Cleveland merchant has turned his door into a show window with the aid of a shelf and a light on a light framework which can be swung into place after the store is closed for the day. In adopting this device lettering on the window must be placed sufficiently high not to interfere with the display. Think of what this added space means to the small shop with a very meager frontage! The novelty of the arrangement has attracted the favorable attention of many people to this ingenious merchant's store.

PEERLESS DE LUXE—

An Exceptional Album for Your Best Christmas Record Trade

This year records will be mighty popular for expression of the Holiday sentiments, but—unlike the past—there will be this superb album to present them in—

PEERLESS DE LUXE.

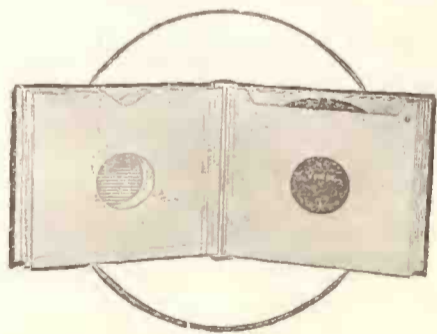

PEERLESS DE LUXE is an album you retail at \$4 for the 10" size and \$5 for the 12" size.

Beautifully bound in two-tone Spanish Mission. Inside covers lined with genuine moire silk, the metal binding gold-plated.

Covers are gold-finished bevel edged.

The record leaves are of excellent quality, satin finish, envelope stock.

It is a gift that will outrank all others this season and indicate to your trade that you respect their demand for quality and rare things.

Regular talking machine discounts allowed.
Get your orders to us at once. Wire at our expense.

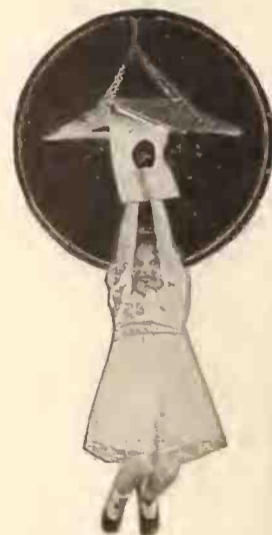

Peerless Album Company

Phil Ravis, Pres.

636-638 Broadway

New York City

Boston Representative
L. W. HOUGH, 20 Sudbury St.

San Francisco Representative
WALTER S. GRAY CO., 942 Market St.



Victrola IV, \$25
Oak



Victrola VI, \$35
Mahogany or oak



Victrola VIII, \$50
Oak



Victrola IX, \$75
Mahogany or oak

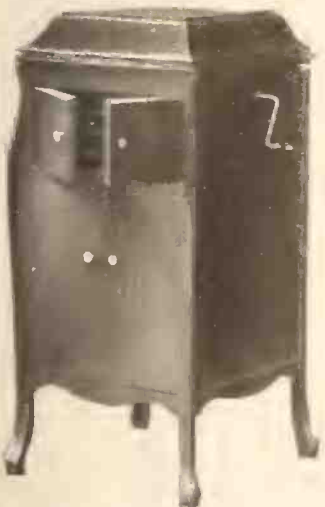

Victrola No. 90, \$125
Mahogany, oak or walnut



Victrola No. 100, \$150
Mahogany, oak or walnut



Victor Supremacy

is universally acknowledged

The Victrola has time and time again demonstrated its supremacy in the great things it has actually accomplished.

It is easy for every Victor retailer to reap the advantages that come with such supremacy.

"Victrola" is the Registered Trade-mark of the Victor Talking Machine Company designating the products of this Company only.

Warning: The use of the word *Victrola* upon or in the promotion or sale of any other Talking Machine or Phonograph products is misleading and illegal.

Important Notice. Victor Records and Victor Machines are scientifically co-ordinated and synchronized in the processes of manufacture, and should be used together to secure a perfect reproduction.

Victor Talking Machine Co.

Camden, N. J., U. S. A.



Victrola No. 110, \$225
Mahogany, oak or walnut



Victrola No. 120, \$275
Victrola No. 120, electric, \$337.50
Mahogany or oak



Victrola No. 130, \$350
Victrola No. 130, electric, \$415
Mahogany or oak

The TALKING MACHINE WORLD

For the makers & sellers of talking machines

(Registered in the U. S. Patent Office)

PUBLISHED BY EDWARD LYMAN BILL, Inc.

President and Treasurer, C. L. Bill, 373 Fourth Ave., New York; Vice-President, J. B. Spillane, 373 Fourth Ave., New York; Second Vice-President, Raymond Bill, 373 Fourth Ave., New York; Secretary, E. L. Bill; Assistant Treasurer, Wm. A. Low.

J. B. SPILLANE, Editor

RAY BILL, B. B. WILSON, BRAID WHITE, Associate Editors

L. M. ROBINSON, Advertising Manager

L. E. BOWERS, Circulation Manager

Trade Representatives: A. F. CARTER, WILSON D. BUSH, C. CHACE, EDWARD LYMAN BILL, V. D. WALSH, E. B. MUNCH, C. R. TIGHE, SCOTT KINGWILL, A. J. NICKLIN

Western Division: Republic Building, 209 So. State Street, Chicago, Ill. Telephone, Wabash 5242

Boston: JOHN H. WILSON, 324 Washington Street

London, Eng., Office: 2 Gresham Buildings, Basinghall St. W. LIONEL STURDY, Mgr.

The Talking Machine World has regular correspondents located in all of the principal cities throughout America.

Published the 15th of every month at 373 Fourth Ave., New York.

SUBSCRIPTION (including postage): United States, Mexico, \$2.00 per year; Canada, \$3.00; all other countries, \$4.00. Single copies, 25 cents.

ADVERTISEMENTS: \$5.50 per inch, single column, per insertion. On quarterly or yearly contracts a special discount is allowed. Advertising pages, \$150.00.

REMITTANCES should be made payable to Edward Lyman Bill, Inc., by check or Post Office Money Order.

NOTICE TO ADVERTISERS—Advertising copy should reach this office before the first of each month. By following this rule clients will greatly facilitate work at the publication headquarters.

Long Distance Telephones—Numbers 5982-5983 Madison Sq.
Cable Address: "Elbill," New York.

NEW YORK, NOVEMBER 15, 1921

BUSINESS DEVELOPMENTS AND PROSPECTS

THERE is evident in the trade a much better feeling in the matter of business growth and business prospects. As the month of October passed by and gave way to November—marking the approach of the Winter season—there came reports from practically every section of the country of a decided improvement in sales percentage, with an indication that normal trade is to be expected in a comparatively short time. By normal trade is meant trade of a volume that should be regarded as standard, and not the great rush of business to which this trade and others have been accustomed during the period immediately following the war.

The reports make it evident, too, that real business is coming to those dealers who have been consistent in their development of selling and advertising campaigns. As an executive of a leading talking machine company recently stated in one of his sales letters, "a hen does not stop scratching when worms are scarce," and the retailers who followed the lead of the humble hen and kept on scratching have found sufficient sales here and there even at the worst of the season to make a fairly acceptable total.

HOW THE WHOLESALE HELPS THE DEALER

IN the talking machine trade, at least, the term "jobber," as applied to the individual or concern who buys from the factory and in turn sells to the dealer, is in a sense a misnomer, in that it doesn't cover his scope as thoroughly as it should and fails to give a proper idea of his usefulness and general helpfulness.

According to Webster a "jobber" is a middleman, and so far as it goes that title covers the wholesaler or distributor of talking machines. It happens, however, that the talking machine wholesaler does not at the present day confine himself to the buying and selling of merchandise, but engages in the much broader work of seeing to it that the products he distributes are merchandised at retail in the proper manner; that the dealer is kept advised of new methods and of new productions; that his stock is of the right sort and properly diversified; that the publicity supplied to the dealer and used by him has the right pulling power and is used to the best advantage, and altogether that the selling of talking machines at retail is carried on most efficiently in the interests of both the dealer and manufacturer.

The day of the so-called jobber who simply received the goods from the factory, reshipped them to the dealer and then took his

profit is past and we now find that the wholesalers of talking machines maintain at their own expense well-trained staffs of representatives who are in constant contact with the dealers, prepared to give advice and assistance needed at the moment. Many of the wholesalers, too, have established educational departments under competent management to develop the use of talking machines in schools, showing the dealer how to get good school business and to train his salespeople to know and to preach good music. Being interested in the final sale of the goods, the wholesalers not only keep contact with dealers, but in many instances operate salesmanship schools for the retailers and their assistants, and bring those same retailers together for frequent conferences where vital business subjects of the day can be discussed.

All this means a substantial expense for the wholesaler, both in money and energy, but it is not unselfish expense because, through aiding and educating the retailer and the members of his staff, retail sales are stimulated to a tremendous degree, a fact reflected in the greater volume of business that comes to the wholesaler.

The thought to be impressed upon the retail trade is the tremendous opportunities that are given the live dealer to profit by the publicity of the manufacturer and particularly by the personal advice and help, as well as the educational facilities, offered by the wholesaler direct.

The policy of following the product from the manufacturer to the home of the ultimate purchaser is not a new one with a number of manufacturers, but for the majority of wholesalers themselves to develop expensive organizations that are efficient, practical and altogether helpful to the retailer, and which extend their efforts through the dealer's entire store and almost into the home itself, is a situation that comes close to being unique.

It is a system that has proved its effectiveness, not only in encouraging the active dealer to greater efforts, which results in a greater demand for both the wholesaler and the manufacturer, but also in stimulating the inactive dealer to display a proper amount of sales effort in taking care of the territory allotted to him.

MUSICAL SEASON SHOULD INTEREST DEALERS

THE musical season just opened will be notable because of the great number of singers and instrumentalists of national and international reputation who will be heard throughout the country. The names that have already been announced by the various musical managers are among those to conjure with in the musical world, several European celebrities coming to America for the first time in many years. Most of these artists are known and appreciated not alone by their concert and recital patrons, but by thousands, nay, millions of people who have become acquainted with them through the medium of talking machine records.

The musical season should prove of direct interest and benefit to the talking machine merchant who sees to it that the musical events in his locality are properly heralded before the public by means of advertising and window displays, so that his identity with the musical activities is clearly established. If the artist is connected in one way or another with some of the products he is selling so much the better for his publicity, but the fact alone that the artist by presenting music in its best form is helping the maintenance and development of his musical instruments is a matter of paramount importance.

Talking machine dealers should realize that the support of high-class concerts and recitals represents music advancement work of the best sort, and it is the work in which the local retailer can assist directly. The stimulation of interest in music means a demand for musical instruments that make music, and it is on that interest that the music industry has been built, and upon which it will thrive. Among the family of musical instruments the talking machine is proving to be one of the greatest developers of musical knowledge, and as the leading singers, pianists and violinists are represented on the records dealers handling these products should make it their duty to keep in close touch with musical affairs in their locality and emphasize the importance and value of the talking machine and the records which accompany it.

There are endless possibilities for the dealer in developing prospects through an intelligent study of ways and means of capitalizing the appearance of these artists in local concerts. Every member of the audience attending these affairs is a "sure-fire" prospect—a prospect that will be steady and not transient—because once the lovers of good music realize that they can actually duplicate in their own

homes the wonderful voices of the singers or the skill of the violinist, cellist, or pianist which they listen to in person they are certain to broaden their acquaintanceship with the dealer's record department.

CONCENTRATING ON HOLIDAY BUSINESS

WITHIN a very few weeks after this issue of *The World* is in the hands of its readers Christmas will have come and talking machine dealers will be figuring on the so-called holiday business which runs from September until the peak on Christmas eve.

It is doubtful if there are any other products subject to a year-round demand that find a place on so many family Christmas lists as talking machines and records. There are probably several reasons for this. The first and chief reason, perhaps, is that, moved by the spirit of Christmas, the average individual is inclined to spend money more freely than at other times and justifies the expenditures by the season. Another reason is that music from time immemorial has played a definite part in this great holiday celebration and then talking machines, particularly records, make gifts of permanent usefulness which are not beyond the pocketbook of the average gift-giver.

That the ordinary individual at Christmas time is moved by the impulse to invest in a talking machine, or to enjoy music or to make a suitable gift, should not be sufficient for the talking machine dealer whose business it is to see that the prospect not only is moved by the impulse but obeys it. The talking machine has developed to a popularity point where to-day the problem of the retail distributor is not that of persuading the prospect of the desirability of the product, but rather of convincing him of the wisdom of purchasing *now*.

The coming of the Christmas season provides a multitude of arguments for prompt buying, and the gathering together and presentation of these arguments at a time when they will do the most good should be the object of the live dealer for the next few weeks at least.

There have been, of course, the usual number of prophecies regarding the holiday business. With some it promises to beat records. With others it will measure up to last year's standard. But the prophecies for good business are going to be borne out only to those who do not confine themselves to the beaten paths in going after business, but who work out new ideas of their own and take the fullest advantage of the psychological moment for putting talking machines and records into homes that might otherwise remain unsupplied for months to come.

MAKING RECORD RELEASES BETTER KNOWN

THE increasing number of daily newspapers devoting regular departments to a discussion of the current record releases, giving to their readers first-hand information regarding the particular features of the various records and listing them carefully by make and number, emphasizes anew the important public position held by the talking machine, for the big dailies are devoting type space only to matters that will interest a substantial number of readers.

Talking machine dealers should encourage and support the daily

papers in the carrying on of this record review, for it is calculated to revert directly to their benefit and reach prospects who might otherwise remain hidden indefinitely. There are, of course, many prospective record purchasers who follow up the new monthly lists of their own initiative and still a great many others who respond to the publicity matter sent out by the dealer. But there are undoubtedly many thousands who will respond to the newspaper review more quickly than to any other suggestion. It may be that at the moment they are not interested in records, but, reading the analysis in the course of their regular perusal of the newspapers, take time to go into some of the details and are moved by descriptive matter to purchase some of the records featured.

Regardless of the direct effect of publicity there is no doubt of the indirect effect of keeping before the public at regular intervals matter relating to talking machines and records and thereby building up a more general understanding of the wealth of music that is offered in record form.

MAINTENANCE OF SOUND CREDIT POLICIES

OMAR KHAYYAM in his inimitable book of verse is responsible for the advice to take the cash and let the credit go, but the progress of business has forced Omar's advice into the discard just as prohibition has eliminated his favorite tippie. Credit to-day is recognized as the foundation of business and the chief means for trade development, but it happens that although credit is a good thing when used properly it has many disadvantages when abused. And during the period of inflation that has just passed by there is no question but that credit was abused.

In looking over the general business situation in other fields of industry, there is ground for congratulating the talking machine trade upon the manner in which the financial house has been kept in order. There have been credit abuses in this trade, but the percentage has been comparatively small in view of the extent and scope of the industry. With the established houses the matter of credits has been kept under such careful control that the basis of credit is accepted as a condition upon which all business calculations must be based.

The result of this has been the solidifying of the industry. It has discouraged over-expansion, has stimulated selling effort along healthy lines and in other directions has tended to keep things moving when under other conditions they might have remained dormant temporarily. The financial disasters that have overtaken some of the concerns in the industry during the period of reconstruction have emphasized rather than belittled this credit soundness, for these failures have been so few and far between as to attract attention from that fact alone.

It is to be hoped that in the period which is to come the sound credit policies of the trade will be maintained and that, where the occasion arises when it is deemed advisable to go beyond the hard-and-fast credit rules that have obtained, the method adopted will combine cautiousness with leniency.



NEW TELEPHONE NUMBER
FITZROY 3271—3272—3273



THANKSGIVING

The Victor retailer, who is and has been exclusively Victor, has undoubtedly much to be thankful for on this prescribed day.

ORMES, Inc.

Wholesale Exclusively

15 West 37th Street

New York



The Joyous Lilt

of the new Gennett Dance Records is giving lovers of the dance a new delight. And Gennett vocal and instrumental selections, too, breathe the very life and soul of the artist.

SELECTIONS FROM THE NEW NOVEMBER LIST

- | | | | |
|--------|---|---------|---|
| 4766 { | HONOLULU HONEY (Weslyn-Applefield-Oyson),
Hart & Shaw, Acc. Hawaiian Orch. | 4773 { | ROSY CHEEKS (Squires)—Fox-trot,
Hazay Natzy and His Biltmore Orch. |
| .75 | SWEET HAWAIIAN GIRL OF MINE (Perry),
Hart & Shaw, Acc. Hawaiian Orch. | .75 | WHY, DEAR (Cohen)—Spanish Chant, |
| 4770 { | REMEMBER THE ROSE (Intro.: "Always") (Simons-
Kroll)—Fox-trot Merry Melody Men | 10045 { | CARMEN OHIO (Cornell)—Spanish Chant,
Criterion Male Quartette, Unacc. |
| .75 | ALL BY MYSELF (Berlin)—Fox-trot,
Merry Melody Men | 1.00 | OHIO AND ACROSS THE FIELD,
Criterion Male Quartette, Band Acc. |
| 4771 { | SECONO-HAND ROSE (Clarke-Hanley)—Fox-trot,
Van Eps Quartette | 10047 { | STAND UP! STAND UP FOR JESUS (Duffield-
Geibel),
Criterion Male Quartette, Acc. Brass Quintette |
| .75 | MA (Conrad)—Fox-trot Van Eps Quartette | .90 | WHEN THE ROLL IS CALLED UP YONDER (Black),
Criterion Male Quartette, Acc. Brass Quintette |
| 4772 { | WHEN THE HONEYMOON WAS OVER (Fisher),
Sam Ash, Tenor, with Orch. Acc. | 10048 { | MARCHING THROUGH GEORGIA,
Criterion Male Quartette, Acc. by Band |
| .75 | TUCK ME TO SLEEP (Lewis-Young-Meyer),
Sam Ash, Tenor, with Orch. Acc. | .90 | PATRIOTIC MELODY,
Criterion Male Quartette, Acc. by Band |

THE STARR PIANO COMPANY, Richmond, Indiana

NEW YORK CHICAGO LOS ANGELES BIRMINGHAM DETROIT CINCINNATI
CLEVELAND INDIANAPOLIS LONDON, CANADA

The Value of the Really Personal Letter in Solving Dealers' Selling Problems :: By Fred H. Parson

There has been so much said and written regarding modern efficiency in letter writing, and particularly the effectiveness of well-thought-out form letters, that there is a tendency in some quarters to overlook the result-producing character of a personal letter designed to make a definite appeal to a particular individual and on a special product. With monthly record lists and an abundance of excellent sales-producing literature to circulate talking machine dealers are of necessity largely dependent upon their mailing list to keep in contact with customers and prospective customers. With a large mailing list to look after the dealer is practically forced to resort to the form letter to place his arguments before customers and prospects and in a majority of cases finds these form letters produce sufficient results to justify their use.

It happens, however, that in many cases a form letter does not make the desired impression upon the recipient. In the first place the average man, especially if he is engaged in business, gets numbers of form letters of various sorts every day and is inclined either to pass them by with a cursory glance or throw them into the waste basket, in the belief that they simply represent advertising matter. The enclosure of a record supplement or other literature will, of course, serve to attract special attention if the recipient is really interested in his machine, but it frequently happens that the talking machine owner is of the type that does not respond to a general appeal. In this case the personal letter answers the question.

It is nothing unusual nowadays for the live dealer to maintain a card file of his customers, the card giving not only information regarding their credit standing, etc., but details about previous record purchases and facts relative to the musical taste displayed by the customers. These card files are designed primarily for the use of salesmen who believe in personal service and seek to keep the permanent patronage of customers through their evident familiarity with their requirements. It likewise happens that dealers generally carry a card index for the purpose of recording requests for records that cannot be filled at the moment, although such a list is not so large or, in fact, so necessary as it was.

It is a mighty good thing to continue, especially in cases where the dealer does not carry a large general stock. Both these card lists can be used in conjunction most effectively in providing an excuse for writing a personal letter to the customer. If the record comes in for which he has made inquiry it is but natural to write a letter—not simply a business card—advising him of the fact and suggesting that he call and purchase it. The writing of the letter also affords the opportunity for bringing to the customer's attention other records which have just been received, particularly those in the latest lists that, judging from his previous purchases and the musical taste he has evidenced, should be interesting to him.

It may be that the customer has persevered in his original request for a special record and does not purchase it when the dealer has managed to get it in stock, but he is certainly going to appreciate the courtesy of the dealer in writing him and, as experience has proved, is quite likely to drop in and buy one or two other records, if only to show his appreciation of that courtesy. In such a case the personal letter is absolutely necessary.

One dealer during the great record shortage drafted an attractive form letter with space left for the filling in of the customer's name and number, but the plan practically fell flat. Al-

most anyone, even a record customer, likes to feel that the matter upon which the dealer is writing him is of sufficient importance to warrant the time and thought necessary for the writing of a personal letter. One such letter is worth a hundred form letters, for no matter how carefully the latter are worded they must of necessity be of a general nature in order to cover as wide a field as possible.

Another occasion for the use of a personal

Certain Cases in Which the Usual Form Letter Does Not Secure the Desired Results—Some Reasons—The Remedy

letter comes when, in going over his mailing list and checking back on the various purchases made by those whose names are on that list, the dealer finds that a former good customer has not been buying at the usual rate during the past few months. This is the time when the dealer is called upon to remind the customer of former substantial purchases and suggest that a visit be made to the store in order to select from the list of newer records that are in keeping with

those already bought. This requires the compiling of special record lists and takes time and thought. The effort is worth while and the direct appeal brings back into line a good patron.

Above all the personal letter must be courteous and well written. There has been a tendency for some time past to inject what is termed "pep" in correspondence—the adoption of the "hail-fellow-well-met" form of expression—a display of familiarity in addressing a customer. This form may be all right for a warm, personal friend, but no matter how cordial the customer may be when he meets the dealer on visiting his establishment he invariably demands that he be addressed respectfully in his correspondence. Language that will provoke a laugh when used in the course of direct conversation often appears downright uncivil, if not offensive, when presented in the form of the printed word. The grin, or sparkle of the eye, that goes with a smart bit of repartee when offered in person is lacking in a letter. It is quite possible, too, to have the letter original in character and bright and snappy, while still keeping within the bounds of civility.

FAIRFIELD NEW SONORA SALESMAN

OMAHA, NEB., November 2.—J. A. Fairfield has joined the forces of the Lee-Coit-Andreesen Hardware Co., of this city, as traveling salesman for the Sonora phonograph and Okeh records. Mr. Fairfield is well known in the trade, having traveled over twenty-five years selling pianos and phonographs. He is also a composer of note.

SEND FOR YOUR SAMPLE TO-DAY

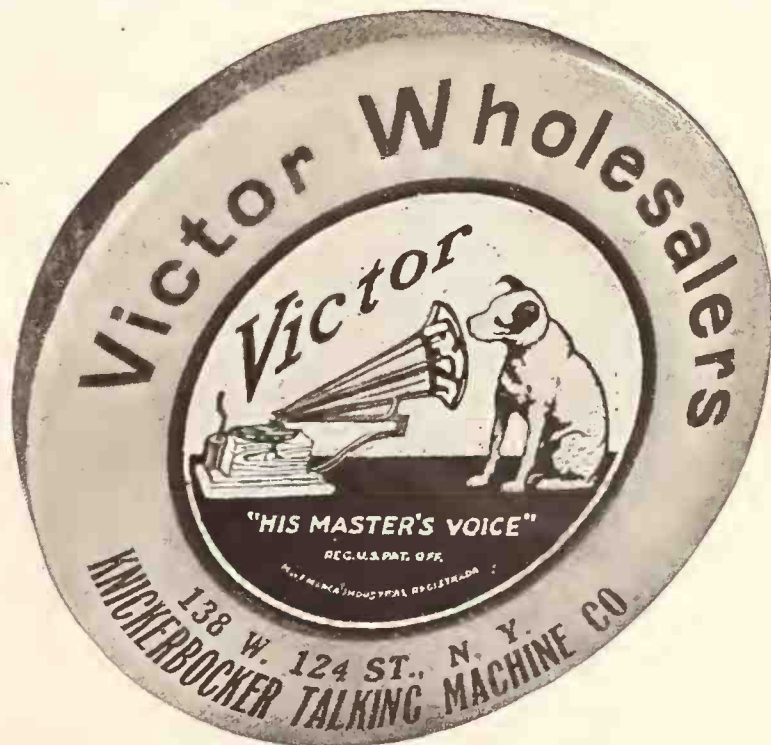

Mr. Victor Retailer—

Would you spend 15c to bring a customer into your store and keep your name constantly before a Victrola owner?

We'll say you will! That is why we will send you a free sample on request of our Advertising Sales-Building-Record Brush.

YOUR ad inserted without extra charge.

KNICKERBOCKER TALKING MACHINE CO.

138 West 124th St.

Victor Wholesalers

New York City

Sell a Carload of

Others Have—You Can Too

You can sell Grafonolas by the carload. We know you can because these Columbia merchants have *done* it.

knowing it was there, with courage and confidence.

What they have done you can do.

These photographs and clippings tell their own story of success—a success repeated time and again in all sections of the country.

You have the "edge" on them because all the experience they paid for in real money is ready for you without cost.

These merchants wanted business, just as you do.

If you want real business, big business, *start* after it now. Write at once for the complete plan.

They went after business,

COLUMBIA GRAPHOPHONE COMPANY, New York City
Canadian Factory: Toronto

QUARTER CENTURY FOR BOTEFUHR'S
WELL KNOWN MUSIC STORE HAD SMALL BEGINNING IN PITTSBURG.

For twenty-five years Botefuhr's have been in business in Pittsburg, and those twenty-five years have seen a growth which now registers the firm as one of the very few outside the large cities who can supply every demand of the musical public.

It was a quarter of a century ago that Frank S. Botefuhr opened for business in the store room now occupied by Treadwell-Williams Jewelry store. There have been several other locations since then. Botefuhr's have been at 613 North Broadway for the past three years. Carl Botefuhr, Mr. Botefuhr's son, has been connected with the firm for several years.

Previous to establishing a business here, Mr. Botefuhr was in business one year at Fort Smith, Ark. However, he has been a resident of Pittsburg thirty-five years, coming here about nine years previous to going to Fort Smith. For seven years he was in the lumber business here with Lee Van Winkle, and later became a teacher of violin, playing at a local theater. It was at that time that Mr. Botefuhr first ventured into the music business, having a window rented in the F. F. Rutz 99c store for display purposes.

From that first start, the business has grown to one of the largest in the southwest. There are four distinct departments—pianos, talking machines, sheet musical and miscellaneous musical instruments.

The F. S. Botefuhr & Son player pianos, manufactured by the Lester Piano company according to specifications of the local firm, have been successfully introduced in this section of the state and have met with approval.

In keeping with the policy of the store to keep in stock "everything musical," period design phonographs made by Columbia, have been recently added. Two designs, the Chippendale and Italian Gothic, are now available. These instruments are examples of wonderful workmanship, depicting furniture of various periods of time. The first is 1754, made after the design of a craftsman, Chippendale. The Gothic is designed after a century original, having features which lend a deep appeal.

Botefuhr's is one of the firms connected with the Pageant of Progress movements appearing constantly in The SUN.

CAR LOAD OF GRAFONOLAS
Botefuhr's Receive One of Largest Shipments Sent Into Kansas.

A carload shipment of Columbia Grafonolas, one of the largest allotments of this type ever shipped into Kansas, was received yesterday by Botefuhr's. A parade was staged yesterday afternoon on Broadway, shortly before 3 o'clock, in which seven large trucks loaded with instruments participated. That number of trucks were required to handle the huge shipment.

There were approximately 130 instruments in the car lot, bringing the total number of machines on the floor at Botefuhr's to approximately 225.

CARLOAD SALE

Columbia Grafonolas

FIRST CARLOAD
Of Columbia Grafonolas
Shipped to Montgomery

Sale Begins Monday, Aug. 8th, 8 A. M.

\$1.50
Will Deliver Any Grafonola to Your Home

Terms as Low as **\$1.00** Weekly Play as You Pay

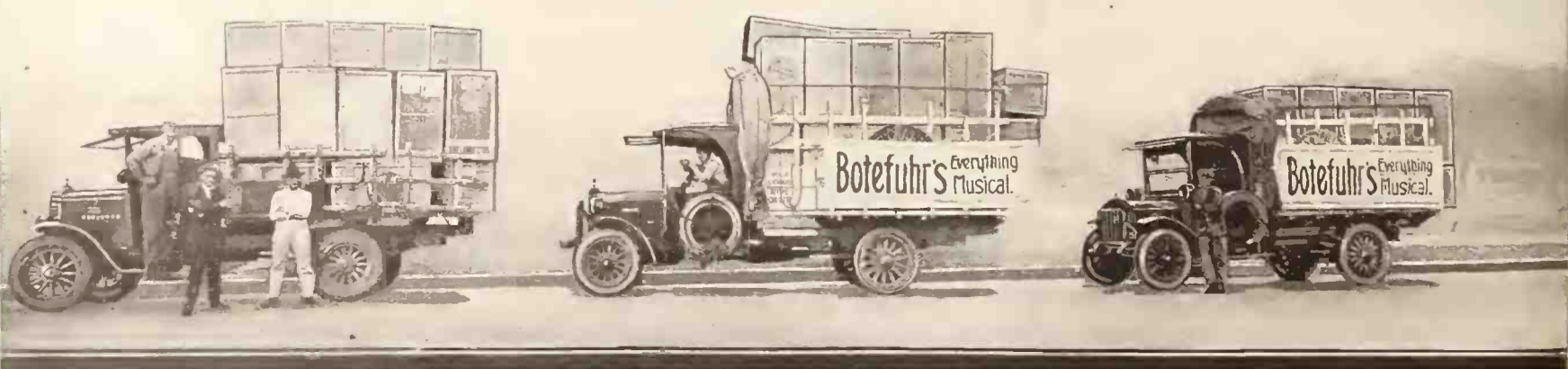

Columbia Grafonolas



Above—Carload Sale Parade staged by the W. S. Hall Furniture Company, Knoxville, Tenn. Center—The Hall Company's publicity. Across Page, Below—Seven solid truckloads of Grafonolas for Botefuhr's, Pittsburg, Kansas. Extreme Left—Botefuhr's publicity. Left Center—Advertisement of Jesse French & Sons Piano Company, Montgomery, Alabama.



GRAFONOLAS IN CARLOAD LOTS

W. L. Hall Furniture Co. Unloads Solid Car Here Today For Fall Trade

Having the greatest faith in increased business for this fall and winter in Knoxville the W. L. Hall Furniture company this morning received a car load of Columbia Grafonolas from the factory at Bridgeport, Conn., which will be placed on sale Saturday morning one of the biggest sales of its kind ever attempted in Knoxville. The machines were unloaded from a freight car that carried large streamers reading: "Rock Island Special loaded with Columbia Grafonolas, consigned to the W. L. Hall Furniture Co., Knoxville."

C. B. Imrie, Southern sales manager from the Columbia company, Knoxville and will remain during the week which is to continue for one week. Mr. Imrie said that his company, to increase production during the past months when business in many parts of the country was at a standstill, kept their factory at work a full time and have been able to manufacture the machines so that reductions can be made for this special sale. The reduction in prices ranges as high as forty per cent.

The entire car load of talking machines was loaded into large trucks and passed through Gay and adjoining streets and into the residential sections of Knoxville. After a two hours' tour through the city the machines were unloaded at the front where they attracted a great deal of attention. H. C. Fowler, manager of the talking machine department of the W. L. Hall Furniture Co., was kept busy today as well as several salesmen demonstrating the machines to prospective buyers.

Mr. W. L. Hall, of the furniture Co., said this morning that he was the first person in Knoxville to get the agency for the Columbia machine and during the twelve years he had sold them that he had never had a dissatisfied customer.

"A CLEAN, CONSTRUCTIVE NEWSPAPER" WEDNESDAY, SEPTEMBER

SOLID CARLOAD OF GRAFONOLAS IN A SINGLE ORDER

The above picture shows one solid carload of Columbia Grafonolas, consigned to W. L. Hall Furniture Co., being unloaded in front of that firm's store on Gay street. The photo was taken immediately after trucks had unloaded and residential sections of the city. Signs on the parade trucks reading, "Our Terms Make Buying Easy," "Play As You Pay," "All Columbia Grafonolas Back to Pre-War Prices," etc., raise people of Knoxville an idea of the bigness of the sale and the wonderful savings effected by reason of the Hall Furniture Co. buying these popular phonographs in carload lots.

Mr. Fowler, manager of the music department of W. L. Hall Co., reports a tremendous increase in business as the result of the advertised low prices and easy terms, and says the carload will not last the week if business continues with such a rush.

The sale is under the personal supervision of C. B. Imrie, who represents the Columbia Grafonola Co. Mr. Imrie reports the sale one of the biggest ever held in the south. He is a strong advocate of fairness in business dealings, coupled with progressive business methods of merchandising and comments that the Columbia company did the one great thing in the phonograph world when it assumed a loss totaling millions of dollars that its dealers might without hesitation reduce retail prices to the pre-war level.

The W. L. Hall Furniture Co. will continue the carload sale of Grafonolas throughout the entire week.

BIG CONSIGNMENT OF GRAFONOLAS HERE

Big Sale Opens Today At W. L. Hall Furniture Store.

A box car load of Grafonolas from the Columbia factory will be offered for sale today at the W. L. Hall Furniture store on South Gay street, for 12 years Columbia agent in Knoxville.

The consignment was unloaded yesterday and carried over some of the principal streets in a detour to the furniture store. The car that brought the machines here was specially marked, coming from Bridgeport, Conn.

The sale beginning today will continue a week under the direction of C. N. Imrie, of Atlanta, southern sales manager for the Columbia company. A reduction in price of 40 per cent is made as the machines after the war have been made at lower cost, it was stated.

H. C. Fowler is manager of the Columbia department of the W. L. Hall Furniture company. Mr. Hall owner, says he has not had a disappointed customer during the 12 years he has had the Columbia agency.



FUNDAMENTALS OF SALESMANSHIP

Wm. Maxwell Gives Some "Pointers" on Closing a Sale That Are Distinctly Interesting

Discussing the fundamentals of salesmanship before a recent meeting of the Representatives' Club, of New York, Wm. Maxwell, first vice-president of Thos. A. Edison, Inc., covered this subject in his usually interesting and comprehensive way. His address, summarized, follows:

Salesmanship is one of the few callings in life that are not rich with traditions. It has really but one tradition: "Salesmen are born and not made." This idea, persisting as strong as ever to-day, has prevented salesmen from learning the fundamentals of their calling from other salesmen. After describing the various phases of a sale, he remarked that the salesman who has been properly grounded does not work his closing of sale with the thought of obtaining a straight "yes," but rather that he so guides the closing that it becomes impossible or embarrassing for the prospect to say "no."

In dealing particularly with salesmen of advertising as an illustration of a need for more fundamental training he declared that from his experience as a buyer of advertising he could say that such salesmen present too much evidence for their proposition. The superabundance of argu-

ment tends to bewilder the prospective advertiser.

He referred to the indorsement given advertising by the Committee on Emergency Measures by Manufacturers of the National Conference on Unemployment, appointed by President Harding. This semi-official indorsement of advertising as a service, he declared, will be instantly grasped by the salesman who understands the fundamentals of his calling as a means of showing the non-advertiser, in a new way, the reason why he should advertise.

OPENS VERY ARTISTIC QUARTERS

Alec Robinton recently held a formal opening of his new studio quarters at 22 Otsego street, Iliou, N. Y. Representatives of the Brunswick and Starr phonograph companies and other concerns were present, and a number of prominent vocalists participated in the concert which formed an interesting feature of the event. There were souvenirs for the general public and congratulations galore on the very artistic quarters arranged by Mr. Robinton. Apart from his very handsome store there is a concert hall, studio and workroom, all of which are ideally appointed, which received praise from the large crowd in attendance. A complete line of Brunswick and Starr phonographs as well as a large record library offer a wide selection to customers.

AN IDEA FOR A WINDOW DISPLAY

How Interest in Record Sales May Be Stimulated by Use of an Original Suggestion

The following may be a good idea for a window display to show the public the relative selling popularity of various new releases of popular records:

Arrange the floor of your window to resemble an automobile race track and on this place three or four miniature automobiles with names and numbers to correspond with certain popular records, the sale of which you wish to promote. Give a position in the race to each car which will correspond with the sales volume of that particular record and then insert in front of the window a bulletin explaining that this race indicates the relative popularity in your city of the different selections assigned to the several cars.

MEET MISS GOLDMAN!

David Goldman, auditor of the General Phonograph Corp., New York, is receiving the congratulations of his friends in the trade upon the arrival at his home the other day of a baby girl, who has been christened Selma Rita. In acknowledgment of these congratulations Mr. Goldman states that his baby girl is "Okeh."

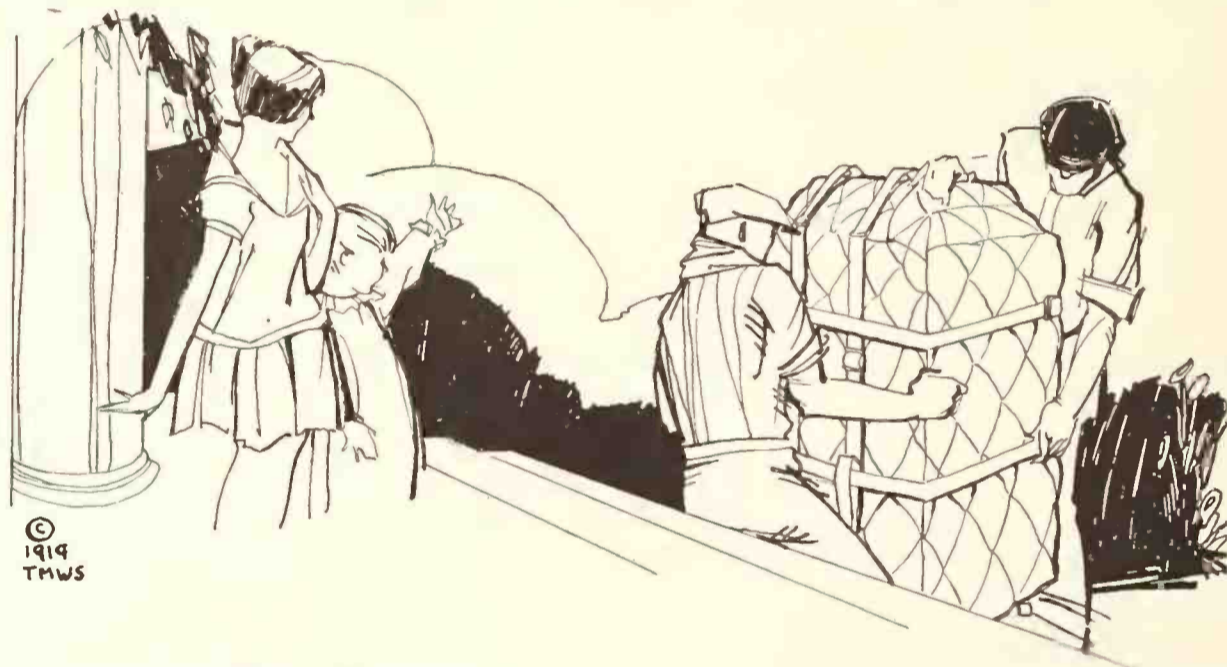

How many talking machines will You deliver this Winter?

A diagnosis of the talking machine trade shows that it is "spotty." Certain localities show better sales than others. Certain establishments, in particular cities, show far greater increase of sales than other establishments in the same city.

Is your establishment going to be one of the bright spots or dull spots this season? The manner in which you handle your sales promotion is a large factor in increasing your sales.

The class that does a good business will be handling reputable merchandise, and selling it by every conceivable, practical method of sales promotion, not the least important of which will be advertising.

By actual test of several hundred merchants like your-

self in their respective newspapers, we have established the fact that talking machines and records can be successfully advertised with smaller space than most stores are now using, and that by increasing the variety of appeal, by dovetailing your window display and direct mail efforts with your newspaper advertising, and by being brief and to the point, a small appropriation can be made to bring a substantial volume of people and sales to your store.

Our Service includes such an advertising campaign, in conjunction with the proper window displays and form letters. Our Service will help you to economize in your sales promotion effort, and at the same time make you a bright spot in your locality. Write for particulars.

TALKING MACHINE WORLD SERVICE

373 Fourth Ave., New York

Under the auspices of



Phone Madison Square 5982

RECORDINGS OF HIGH NOTES

Compilation of Recordings Shows the Attainment of a Perfect Harmonic "G"

In a recent letter sent by E. F. Droop & Sons Co., Victor wholesaler, Washington, D. C., to its dealers some interesting facts which are not as generally known as they should be are presented. These data should serve excellently for the salesman in conveying to customers important facts regarding some of the remarkable recordings in the Victor catalog.

The following series of accomplishments in the perfect recording of not only high "C," but of even higher notes on the Victor records, are given:

"In 1904 Sembrich recorded a perfect high 'C' in Victor record No. 96200 (Lucia—Chi mi frena).

"In 1905 Tetrizzini recorded a perfect high 'D' flat in Victor record No. 96201 (Lucia—Sextette). Sembrich also recorded this high note in record No. 96001 (Rigoletto Quartet).

"In 1911 Tetrizzini recorded a perfect high 'E' flat in Victor record No. 88296 (Mignon—Poisonaise). Garrison also recorded this note in record No. 64811 (Vous dansez, Marquise—Marchioness, Your Dancing). High 'E' flat is also recorded in record No. 74509 (Lucia—Mad Scene, by Galli-Curci).

"In 1917 Galli-Curci recorded a perfect high 'E' (!) in Victor record No. 74510 (Lakme—Bell Song).

"In 1915 Kreisler in Victor record No. 64503 (and also Heifetz in record No. 64823) recorded a perfect harmonic 'G'.

"Harmonic 'G' is nine tones higher than Galli-Curci's high 'E,' which is an unusual mark even for high sopranos—and eleven tones higher than the much-advertised and encore-producing high 'C'."

It is worth remembering: It is not when you know how to do a thing that you get results; it is when you do it.

HARLAN AND COLLINS IN CONCERT

Noted Recording Artists Featured in Ohio in Connection With the New Edison

YOUNGSTOWN, O., November 3.—Harlan and Collins, noted recording artists, have won many friends in eastern Ohio, where they have been appearing under auspices of local Edison dealers in concerts. Fostered by the Homer Williams Co., the two artists appeared here on October 19 in the Masonic Temple, where they pleased a large audience of music lovers by comparing their singing with its re-creation by the New Edison phonograph, in addition to rendering several groups of songs on their regular program.

Later they appeared in New Philadelphia, O., under the direction of George E. Buss, local distributor, at the Union Opera House, repeating their former success.

Large crowds have been greeting the artists in every city where they have appeared. A score of other eastern Ohio cities will be visited before the two artists leave this territory.

ANOTHER TRIBUTE TO CARUSO

In The Voice of the Victor for October there is published an elaborate tribute to the late Enrico Caruso and there is reproduced on a special page, one of the latest portraits of that noted artist. The tribute is admirably written in a broad vein, showing the scope of the man and his art, and little reference is made to Caruso's work in the matter of records.

N. E. MILLER HANDLES VOCALION

DANVERS, MASS., November 5.—The N. E. Miller Co., popular local music house, was recently appointed the agent in this vicinity for the Vocalion and the Vocalion records. The company is planning an aggressive campaign for the sale of these instruments in its territory and, in addition to advertising in the local papers, will circularize its prospects.

REACHING THE SLOW CUSTOMER

How Best to Plan Means of Stimulation—Salesman's Personal Letter Effective

When a customer doesn't appear on the scene or order anything for some time it is a good plan to write him a personal letter. One concern holds a monthly meeting of its sales force, at which buyer absentees are the chief topic of discussion. The possible reasons for each regular customer's continued absence are noted, and the salesman thought best able to deal with the customer is commissioned to write him a personal letter. This concern uses no form letters, so that each letter is specially adapted to the individual customer. Another concern, doing a large credit business, maintains a card index, which shows whether or not a customer has purchased anything during the month. Reference to this index at regular, frequent intervals enables the sales force to follow up any regular customer who has not been buying for some time. Form letters are used for this purpose, as the concern's business is too large to admit of personal letters in this case, but each letter is typed and signed personally by the head of the firm. As the typist knows the form verbatim, the typing process is accomplished in less time than one would imagine. A slight error is made deliberately to identify the personal character of the letter.

BRILLIANTONES NEWLY ENVELOPED

The Brilliantone Steel Needle Co., New York City, is now presenting Brilliantone dance needles in an especially prepared paper envelope described as "glassy." The needles within are visible and the envelope at the same time protects them from rust or other atmospheric effects. The Brilliantone Steel Needle Co. reports that the demand for its various needles is continuing very strongly and that this exceptional demand is expected to continue throughout the year. October has proved the biggest month of 1921 in Brilliantone business.



Howdy Neighbors!

Greeting to Ormes, Inc., and Blackman Talking Machine Co.

We welcome two such old friends and representative Victor Distributors as next-door neighbors.

Your choice of location is ideal for service to the dealer.

Ask any Pearsall Dealer, he will tell you

"Desire to Serve Plus Ability."

10 EAST 39th ST.



NEW YORK CITY

SILAS E. PEARSALL COMPANY

DISTRIBUTORS

Announcing REDUCTIONS of Commanding Importance on Entire Cheney Line

THE Cheney Talking Machine Company, desiring to dispel at one stroke any hesitancy that may exist in the public mind as to the stability of prices on Cheney phonographs, has made sweeping reductions in prices of all models.

Built to an ideal—new and scientific principles of construction, co-ordinated supervision of manufacture, control of all operations, and exacting inspection, make Cheney instruments the acknowledged standard of quality.

This supreme quality at retail prices that will immediately attract purchasers, and increased profits to dealers, make the Cheney line of commanding importance to you.

CHENEY TALKING MACHINE COMPANY, Chicago

The
CHENEY
The MASTER INSTRUMENT

How a New Talking Machine Store Was Successfully Put Over in Novel Way :: By F. H. Williams

The use of talking machine records for local advertising purposes looks like a new field which should offer big possibilities to the retail dealer. So far but very few records have been made for local advertising purposes—and yet, why not?

Let's see what is meant by this proposition and just how it might work.

Suppose in some city of a quarter-million or so there is extremely keen competition between the leading dealers in talking machines. A new dealer starts up—John Smith, we'll call him. He is faced by pretty discouraging conditions. The other dealers are very firmly entrenched, they have the trade thoroughly lined up, are progressive, alert and enterprising and it looks as though Mr. Smith were going to have mighty hard sledding.

Mr. Smith, after a few weeks of experience, thinks so himself. But he isn't of the stuff that gives up easily and he looks around for some novel method of putting himself and his store over quickly and in a big way. But how can he do it? Advertise? Yes, but all the other stores are advertising. There wouldn't be anything particularly new or novel or unusual in another talking machine store advertising. Put out salesmen? Yes, of course, but he hasn't any bulge on his competition there—that's what they're all doing.

What, then, can he possibly do to jolt the public into attention and make them flock to his store for the purpose of buying talking machines and records?

After considering the proposition for some time Mr. Smith turns to the talking machine itself as the best way out. He gets in touch with the foremost local musician, a man who has composed a number of instrumental selections which have made quite a hit locally, although they haven't done much outside this particular city. He makes a proposition to this musician to give him more local publicity than he has ever had before if he will give, free of charge, the entire record rights to Mr. Smith of his latest composition. Failing in this, as he is quite apt to do, he pays the musician a small sum for the use of his work. Mr. Smith tells the musician just what he is going to do with the piece and points out that it is entirely an advertising and publicity scheme in which the

musician has just as much to gain as Smith himself.

But what does Mr. Smith intend to do with the music?

Listen. He makes a proposition to the company whose products he is handling that this concern make a certain number of records of this musician's piece, having the concern's regular orchestra do the playing. Smith guarantees that he will sell enough of the records to pay for their manufacture. The manufacturing concern takes him up. The records are made and in due time they arrive at Mr. Smith's place of business.

And then what does Mr. Smith do with them?

First he embarks upon an extensive advertising campaign. His first newspaper advertisement reads like this:

THE FIRST LOCAL MUSICIAN'S WORK TO BE REPRODUCED ON TALKING MACHINE RECORDS!

Carlo Sebastian, the well-known local musician, has composed a new instrumental selection which is a knock-out. It has been reproduced on talking machine records by the Doitwell Talking Machine Co. and the records are now here! They are priced at \$1.00 each.

Come to Smith's talking machine store and hear this first and only local musical record. You'll be delighted by it—it is the sort of music you will long remember, the sort of music that makes the dance seem better. Then buy a record. Play it on your own talking machine. Have it ready to play for any visitors from out of town. Show strangers in our city just what this city can do in a musical way.

Come in NOV and be among the first to hear the first local talking machine record ever made.

THE JOHN SMITH PHONOGRAPH SHOP
44 Market Street

Following this initial announcement come other ads, all playing heavily on the local pride feature of the proposition and urging every talking machine owner in the city to purchase one of the records so they can demonstrate to neighbors and to visitors just how good this prominent local musician is.

But newspaper advertising is not the only avenue of publicity which Smith adopts for the purpose of calling attention to Sebastian's record and in this way attract attention also to his shop.

He tells the local city editors of the newspapers all about the affair. The fact that the record is the first local musical record ever made appeals to the editors as being a good news

story. They play the affair up in their news column, running pictures of Sebastian and of Smith. The affair is treated as a news story of real interest to everyone in the city, which is, of course, exactly what it is.

Smith then takes the matter up with the superintendent of schools. He gives to the superintendent enough records for all the machines in the schools, his only stipulation in making the gift being that when the record is first played the teachers tell the scholars that the record is the work of Mr. Sebastian and emphasize that they have been made through Mr. Smith's enterprise. Smith points out that the playing of the record in the schools may be made the excuse for quizzing the scholars as to what they know about local history and local achievements. The superintendent, of course, willingly falls in with the plan.

Next Smith induces the local bands to play the selection upon every possible occasion and he features such playing in his newspaper advertising, calling attention to the fact that the piece is growing in popularity and that it should be in the home of everyone who enjoys good music.

Next he stages a personal appearance of Mr. Sebastian at the Smith store. He plays his piece on the piano and the talking machine record is then played. This affair creates more publicity, attracts more attention and results in more people becoming familiar with the Smith store.

As the result of all this enterprise, advertising and publicity Mr. Smith's store is, in no time, established as the leading and most alert "talker" shop in the town. In fact, when people think or talk about talking machines they think and talk first about Smith and his enterprise in putting Sebastian's piece on a record.

But how could any enterprising manufacturer benefit by such a proposition?

The answer is easy—by hooking himself up with the affair in no unmistakable manner and by promoting such enterprises among his dealers in the larger cities. If the Doitwell concern, for instance, makes it plainly evident that it is the co-operation of this company in furthering all good musical propositions which has made it possible for this local achievement to come about, then the local people will do more talk-

(Continued on page 18)



PROMOTE



THE ECLIPSE MUSICAL CO.

Wholesale Only

Cleveland, Ohio

IMPORTANT TO THE TALKING MACHINE TRADE



SELECTING THEIR FAVORITES

NATIONAL PUBLISHING CO., 239 S. American St., PHILADELPHIA, PA

Record Albums

Yes, Price is one point.
But so is Quality another point.
Quality and Price must be considered together. "National Albums" are unsurpassed and seldom equaled in Quality. They give permanent satisfaction to the user. **Please your customers. Write us for price list.**

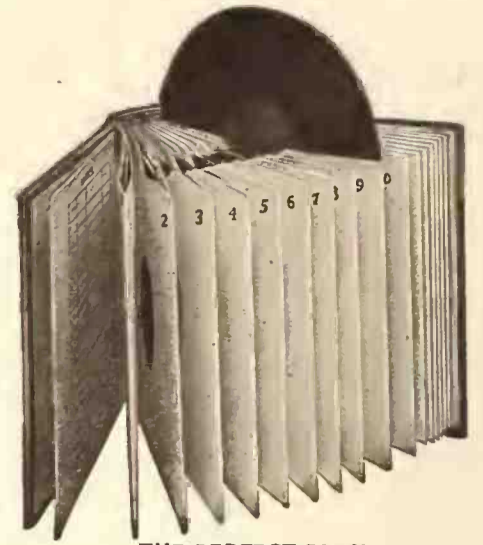

THE PERFECT PLAN

PUTTING OVER NEW "TALKER" STORE

(Continued from page 17)

ing about the Doitwell machine and records than almost any other single thing could bring about.

And the very best thing about the whole proposition is that it would pay its own way. With all the local pride which every city has and with all the publicity which would be given to such a unique stunt, enough records to pay for the whole cost of manufacture and of the advertising could be sold without the least little trouble in the world.

C. J. COLLINS WITH REMINGTON CORP.

Joins Sales Staff in Metropolitan Territory Representing Phonographs and Olympic Records

E. H. Holmes, sales manager of the Remington Phonograph Corp., New York, has announced the appointment of C. J. Collins to the sales staff of the organization covering the metropolitan district in the interest of both Remington phonographs and Olympic records. Mr. Collins has had long experience in the talking machine field and has a large circle of friends in the trade.

Talking machine dealers and salesmen should bear in mind that it takes sixteen muscles to make a smile and sixty-eight to make a frown. Why work overtime?

STARR DEALERS VISIT PLANT

Representatives of the Starr Line of Pianos and Phonographs Inspect Company's Modern Manufacturing Plant at Richmond, Ind.

RICHMOND, IND., October 31.—Nineteen Starr piano, Starr phonograph and Gennett record dealers from Pennsylvania and West Virginia put in a full day at the plant of the Starr Piano Co., in this city, during the month. The party, which journeyed to Richmond from Pittsburgh in a special car, was organized by H. C. Niles, secretary-treasurer of the Starr Phonograph Co., Pittsburgh, and was for the purpose of better acquainting the dealers with the great Starr industry of the Middle West.

Inspection of all departments of the Starr plant was the feature of the day and the fact that every single part entering into Starr-made pianos, player-pianos, Starr phonographs and Gennett records is made complete in the Starr plant was clearly shown.

At noon lunch was served in Building No. 19 in the phonograph department, amid decorations of flags, bunting, together with flowers, plants and boughs, tinged with the autumn colors, making an effective setting for the lunch table. Surrounding the table and extending half-way the length of the great building were displays of the entire line of Starr pianos—uprights, players and grands—Starr phonographs, motors and acces-

sories, and many of the latest Gennett records.

A novel and interesting event of the afternoon was the special making at the factory recording laboratory of a record by the entire party. The Starr Piano Co. now maintains a recording laboratory at the plant, as well as in New York. The record will later be presented as a souvenir to each of those present and in addition to a talk regarding the trip each person spoke his name and business connection into the horn.

In the evening dinner was served, the main feature of which was a whole roast pig, with all the trimmings. Short speeches were made by Jacob Schoenberger, of Lechner & Schoenberger, Pittsburgh, who told of his long connection with the Starr Co. in selling its products; A. G. Leonard, of the R. E. Stone Furniture Co., McKeesport, Pa.; Harry Niles, of the Starr Phonograph Co., Pittsburgh; Harry Gennett and Fred Gennett, vice-president and secretary, respectively, of the Starr Piano Co.

Those making the trip enjoyed the day thoroughly and were especially impressed with the size and completeness of the Starr plant. "I think everyone had a good time and enjoyed the trip immensely," said H. C. Niles, who was formerly advertising manager of the Starr Piano Co. The visitors were: Lester Stewart, the Phonograph Shop, Homestead, Pa.; W. C. Pifer, Keyser, W. Va.; Clark Jones, Jones & McMillen, Beaver, Pa.; Jacob Schoenberger, Lechner & Schoenberger, Pittsburgh, Pa.; George Minch, Minch & Selzer Furn. & Und., Coraopolis, Pa.; W. T. Parker, Vale Summit, Md.; George H. Selzer, Minch & Selzer Furn. & Und., Coraopolis, Pa.; Harlan A. Horne, J. M. Hoffman Piano Co., Pittsburgh, Pa.; E. J. Michael, E. J. Michael Piano Co., Pittsburgh, Pa.; A. K. Smith, Punxsutawney, Pa.; L. M. Lytton, Burgettstown, Pa.; Roy Veiock, Veiock Music Co., New Brighton, Pa.; A. G. Leonard, R. E. Stone Furn. Co., Keyport, Pa.; R. E. Williams, R. E. Williams Music Co., Greenville, Pa.; B. D. McMillen, Jones & McMillen, Beaver, Pa.; Andy Tomasco, Blacklick, Pa.; H. H. Imhoff, Clarion, Pa.; F. A. Stewart and H. C. Niles, Starr Phonograph Co., Pittsburgh, Pa.

BOSTON ALBUMS ARE MADE RIGHT

Patented
1914

Patented
1914

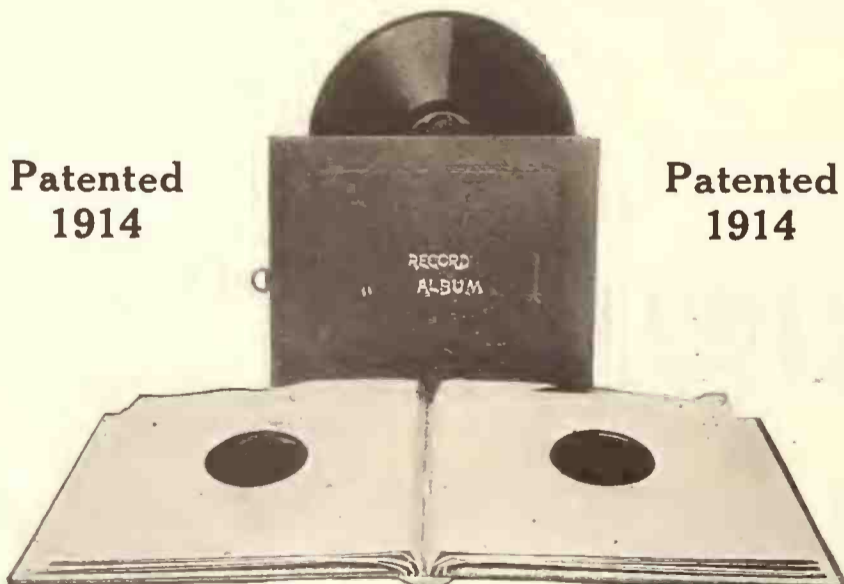

BOSTON ALBUMS are made TO SATISFY YOUR MOST EXACTING CUSTOMERS. This means that Boston Albums are made right and have been since they were Patented and introduced to the Trade in 1914. They have never been equaled.

We invite you to send for samples of our four new models—all made right.

BOSTON BOOK COMPANY

501-509 Plymouth Court

CHICAGO, ILL.

THE BRUNSWICK AT HARDMAN HOUSE

Well-known Phonograph Now Handled in Elaborate Department of Hardman, Peck & Co.

Hardman, Peck & Co., 433 Fifth avenue, New York, announce that the Brunswick line of machines has been added to their talking machine department. Several period models of the Brunswick line will be on display on the main floor, and on the fourth floor, which is devoted exclusively to talking machines, a complete line of Brunswick phonographs will be shown.

Marie Morrissey, contralto and Edison artist, has been giving a number of concerts throughout New England, which have been loudly acclaimed by audiences and critics.

YES!!!

TRUE TONE

THE WORLD'S BEST

PHONOGRAPH NEEDLES ARE THE BEST YOU CAN BUY

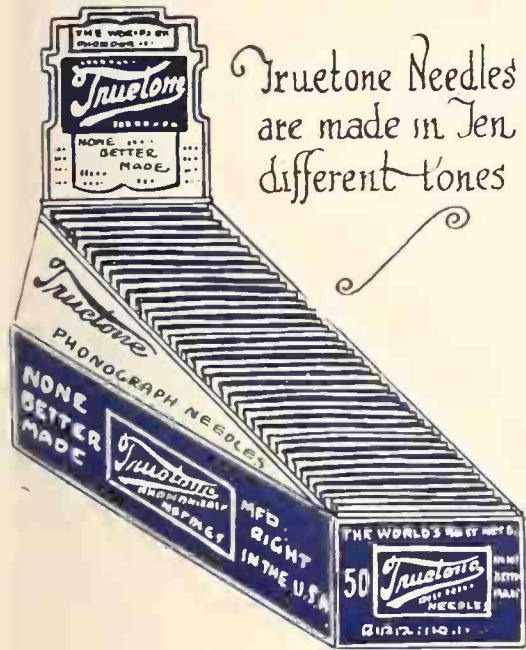

Truetone Needles
are made in Ten
different tones



A BIG HOLIDAY SELLER-TRUE TONE NEEDLES. PUT UP 5000
ASSORTED IN A GIFT BOX - FEATURE THIS NOW

Perfected Points, Perfected Lengths, Perfected Hardness!!!

NOW

is the time, Mr. Distributor, to Supply YOUR
DEALERS with

“THE WORLD'S BEST”

Phonograph Needle

Territory Open for
Live Distributors

TRUE TONE

Write for Our
1922 Prices

REMEMBER!!!
NOWADAYS

IT'S TRUE TONE
THE WORLD'S BEST
PHONOGRAPH NEEDLES

**MICA
DIAPHRAGMS**

Absolutely Guaranteed Perfect
We get the best India Mica directly.
We supply the largest Phonograph Manufacturers.
Ask for our quotations and samples before placing your order.

American Mica Works
47 West St. New York

OPENS NEW TALKING MACHINE SHOP

Drake & Monninger Co. Opens an Exclusive Talking Machine Store in Sebring, O.

SEBRING, O., November 4.—The Drake & Monninger Co., with stores in Canton, Alliance and East Liverpool, has opened an exclusive talking machine shop here in Fifteenth street. The company specializes in household furnishings, but the local store, according to George Drake, manager, will be devoted exclusively to the display and sale of phonographs. There was no formal opening. A complete line of talking machines, records and musical merchandise will be offered by the new shop. This company recently moved into larger quarters in Alliance and added a talking machine department which is second to none in the entire city.

NEW MUSIC SHOP AT GLENS FALLS

GLENS FALLS, N. Y., November 5.—A recent addition to the music establishments here was the Brunswick Music Shop on Ridge street, which was opened by S. B. Cleveland and Harlan Paige, both well known in local business circles. The store, which is modern and extremely attractive, possesses all the latest conveniences for patrons. A complete line of Brunswick records and machines is handled.

MILAN, O., HONORS T. A. EDISON

Town Where Great Inventor Was Born Pays High Tribute to Him in Two-day Pageant

SANDUSKY, O., November 4.—A "historic pageant," arranged as a tribute to Thomas A. Edison, who was born there, was presented twice in Milan, O., recently. It consisted of a series of tableaux, in many of which participants were made up to represent the inventor either as child or man.

On Friday afternoon an heirloom exhibit was placed on display and continued until Sunday. This offered, among other things, autographed photographs and letters sent by Edison from time to time to his cousin and childhood playmate, the late Mrs. Nancy Wadsworth, as well as specimens of mechanical appliances from the Milan High School laboratory, the gift of Edison to the school, and said to be the finest of its kind in the world. An old-fashioned tea cup that belonged to Edison's mother attracted attention.

On Saturday afternoon, in the public square, the celebration took on a spectacular aspect. The pageant and exhibition were arranged by public-spirited Milan citizens as a means of raising money for the Milan public library.

RECORD COLLECTION ON DISPLAY

Display of Various Makes of Records in Window of Roat Music Co. Attracts Attention

BATTLE CREEK, MICH., November 5.—An unusual window display which is attracting considerable attention here is that of the Roat Music Co. The display consists of eighty different makes of talking machine records collected by Roy C. Wheeler, a prominent local business man, who has records made by every company with one exception since the manufacture of the discs started. Only about twenty-five of the records represented in the collection are now being produced. Records made in America, Canada, England, Germany and other countries are included in the collection.

DANCING GIRLS FEATURE OPENING

Four Little Girls in Window Attract Attention to Val Loewer Co., Sonora Dealer, of Columbus, at Formal Opening of Store

COLUMBUS, O., November 1.—An innovation which attracted considerable attention to the Val Loewer Co., Sonora dealer at 130-136 East Main street, this city, was the appearance of four dancing girls in the window of the establishment on the occasion of the recent formal opening of the concern. A Magnavox attached to a Sonora phonograph furnished the music for the little



A Window That Attracted Notice

dancers, who performed before one of the largest crowds that ever attended an affair of this kind in the city. Added success was given to the event by the fact that the music could be heard by the spectators on the outermost fringes of the crowd, which surrounded the window throughout the entire performance. The publicity gained by this novel entertainment will do much to provide for the success of the company and the originality of the event, as well as the success with which it was attended, makes it well worth trying by other concerns as a publicity medium apart from its artistic worth.

Sherry & Son, exclusive Victor dealers, at 3448 West North avenue, have secured a lease on new quarters at 4035 on the same street, Chicago, which are now being occupied.

Grasp an idea and work it out to a successful conclusion. That is about all there is in life for any of us.

GOOD NEWS

Gentlemen of our trade:
Have you not wished a thousand times for a needle that you could with utmost confidence recommend to your closest friend as an entirely satisfactory needle?

DE LUXE NEEDLES

Fulfill every requirement of an entirely Satisfactory Needle.

Ask your Jobbers or Dealers all about them.

Samples and full particulars gladly furnished.

DUO-TONE COMPANY, INCORPORATED

Sole Manufacturers of De Luxe Needles
ANSONIA, CONN.



Full Tone

DON'T FORGET THESE FACTS

Perfect Reproduction of Tone No Scratchy Surface Noise

PLAYS 100-200 RECORDS



Medium Tone

Three for 30 cents (40 cents in Canada)

SEITZ PLANS WORK IN SCHOOLS

Educational Director of Putnam-Page Co. Working With Dealers in Developing Great Campaign Which Is Proving Most Successful

PEORIA, ILL., November 5.—The educational department installed by the Putnam-Page Co., under the direction of H. W. Seitz, recently referred to in The World, is proving a great success. The interest and enthusiasm of the dealers indicate that they are most appreciative of the various plans for helping the sales force and teachers to a proper knowledge of this interesting and profitable work.

The educational value of the Victrola and Victor records is recognized by teachers and thinking



H. W. Seitz

people of to-day. The problem now at hand is that all may be helped in presenting the subject intelligently and to see that each dealer has in his organization someone capable of carrying on the work and assisting teachers in every way possible.

Records for children should be in each home

DIRECT FACTORY PRICE—JUST MENTION THE QUANTITY

MOTORS	CASTINGS	TURNTABLES	Stylus Bars
TONE ARMS	Grey Iron	MOTOR FRAMES	Screw Machine Parts
REPRODUCERS	and Brass for	TONE ARMS	Talking Machine Hardware
		HORNS and THROATS	

Direct Quantity Importations On { JEWEL and STEEL (Bulk or Packed)
PHONOGRAPH NEEDLES
GENUINE RUBY BENGAL MICA

D. R. DOCTOROW

Vanderbilt Ave. Bldg.
51 East 42nd Street, New York
Tel. Vanderbilt 5462
Murray Hill 800

as well as in the school, and dealers who overlook the possibility of placing a small machine and records in the nursery are losing an opportunity to increase sales that would doubtless surprise them.

The Putnam-Page Co. expresses itself as fortunate in securing the services of Mr. Seitz, for his previous training and experience make him unusually well qualified to be of assistance to teachers and dealers. He is a graduate of the Peoria Conservatory in voice, the University of Wisconsin and the Cincinnati Conservatory in public school music, and had special study in voice under John Hoffman and Oscar Saenger, of New York City.

To make the work of commercial value Mr. Seitz will follow his work in the schools with a lecture in which views of interesting scenes and important points of interest of each country will be shown, together with the national and characteristic music of the country recorded by the Victor Co.

If work done at a Teachers' County Institute means a sale of five school machines, six charts featuring the "Instruments of the Orchestra," twelve copies of "What We Hear in Music," twelve copies of "Music Appreciation for Little Children," fifteen copies of "Pan and His Pipes" and 250 Educational Records, who would question the commercial value of the work?

Mr. Seitz sent in this order from Aledo and is now planning to return there and will outline

a course in Music Appreciation for teachers and help them to use the material they have to the best advantage.

Aledo is a town of 3,000, and Mr. Bolton, of Bolton Electric Co., the local Victor dealer, is an



energetic, progressive and wide-awake man, deserving to succeed because of his aggressive methods and sound business policies.

Mr. McNight, of the Bolton Electric Co., will assist Mr. Seitz in his educational work.

BANK GIVES TALKER TO SCHOOL

An Original Advertising Stunt in Canton, O., That Should Be Encouraged

CANTON, O., November 2.—Always on the alert for an advertising stunt, original and new, Frank Collins, vice-president of the First Trust and Savings Bank here, this week presented one of the local junior high schools with a handsome new Sonora talking machine. Presentation was made by the principal at the regular fortnightly assembly. As the result the school adopted the following slogan, "A bank account for every pupil." This bank has a special school children's savings department.

MISS BROWN'S INTERESTING VISIT

Miss H. Marjorie Brown, of C. Bruno & Son, Inc., Victor wholesalers, New York City, recently completed an interesting trip throughout Connecticut and Rhode Island and part of Massachusetts. Miss Brown visited the dealers in the principal cities of these States and was much interested to learn the successful methods they employed in their business and, in return, left with them many valuable ideas for future use. The trip was so satisfactory in these respects that Miss Brown plans to make a trip through New York State at an early date.

OLYMPIC ARTIST NOW ON TOUR

Percy Hemus, popular Olympic artist, is now on tour as star in "The Impresario." The folder announcing the tour, an edition of over 300,000 of which was struck off, is a product of the printing department of the Olympic Disc Record Corp. Of particular interest to the Olympic dealers, wherever this production will appear, is the advertisement of the Olympic Disc Record Corp. appearing in this booklet, which announces that the local Olympic dealer is able to supply solo numbers of "The Impresario" on Olympic records.

Mascagni's latest opera, "Il Piccola Marat," has scored an immense success in Rome and recordings of the opera, or the production of the opera itself at the Metropolitan, are awaited with interest by the musical people of America.



Seaburg Mfg. Co.
Jamestown, N. Y.



No. 250T, List Price \$250.00
Usual discounts to dealers
48"x28"x31" high. Finished all
around
Solid Mahogany, Walnut or Oak



Money for You in These New Creations

You are not getting all there is out of the talking machine business unless you are handling these new *Blue Bird* models. The adaptability of these striking departures from the commonplace in phonographs, for an infinite number of new uses, has opened up a new field of opportunity for the wide awake dealer.



Blue Bird "SPINETTE"

This classic colonial type Spinet Desk, with concealed phonograph, is a supreme achievement of art and utility. One of several "2 in 1" feature pieces. Appropriate for living room or library.

Retail Price \$275

These *Blue Bird* phonographs sell where other phonographs will not. These new creations, which were first announced last month, represent the highest attainment in workmanship and tonal quality; features which have made the *Blue Bird* famous wherever it has been seen and heard. The "Emanator"—an ingenious automatic record container—is one of several distinctive *Blue Bird* features.

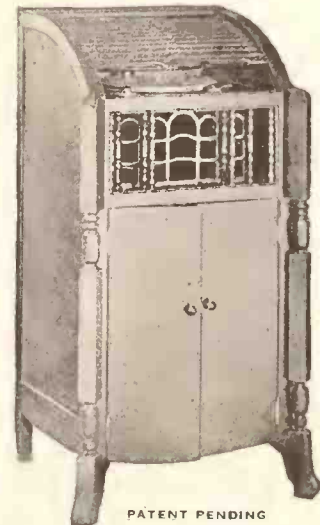

Streamline Model (Disappearing Cover)

The epitome of convenience and elegance

Retail Price \$250

Exclusive Territory for You

Blue Bird phonographs play all records. Better yet, *Blue Bird* records—the latest hit—are now ready for distribution. These, combined with the new *Blue Bird* models, are the only exclusive proposition of the kind, and give the dealer complete independence, as he can also handle the *Blue Bird* period and cabinet models, which fill the most exacting demands for these types.

The *Blue Bird* dealer does not have to compete with a number of other dealers selling the same machine—in the same territory—at the same price.

Write today for the big special *Blue Bird* proposition to dealers

Your territory will be exclusive

Blue Bird "Teakar" Phonograph

Handsomely modeled; adapted to garden parties and other entertainments.

Sliding top for duplex use.

Retail price \$140

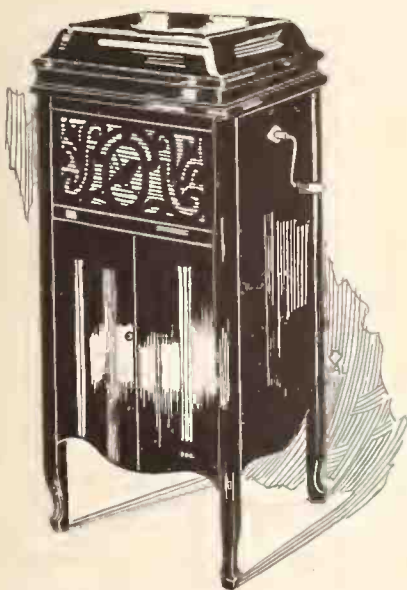

Cabinet and Period Types

Retail from \$65 to \$325

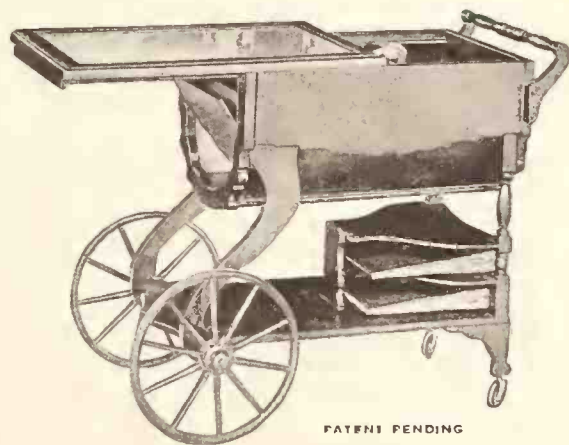

PATENT PENDING

BLUE BIRD TALKING MACHINE CO.

LOS ANGELES · CALIFORNIA



Charles Hackett, as Thaddeus, sings the lovely lament, "Then You'll Remember Me" from *The Bohemian Girl* in his glorious tenor. Your customers will want this newest record by the greatest American tenor. Columbia 79891.

**Columbia Graphophone Co.
NEW YORK**

WHY EDELSTEIN IS DOING BUSINESS

Albany Dealer Installs Electric Sign and Contracts for Twenty Large Billboards

ALBANY, N. Y., November 5.—Al. Edelstein owner of the Strand Temple of Music in this city, exclusive Victor dealer, is not worrying very much about bad business or any other form of pessimism. On the contrary, he is a pronounced optimist, and only the other day purchased a large twenty-five-foot electric sign with



Al Edelstein

a flasher attachment and a new Ford Victrola delivery car.

In addition to these outward signs of optimism Mr. Edelstein has contracted for twenty large billboards in and about Albany and his general publicity campaign will be more extensive than ever before. Needless to say, his sales totals this Fall have been more than satisfactory, and this success may be attributed to his progressiveness and thorough knowledge of the industry.

The first law of all our civilization is the co-operation of all individuals to improve the conditions of life.

CHANGES IN COLUMBIA STAFF

E. N. Burns and A. R. Harris Resign Posts—R. F. Bolton in Temporary Charge of Recording Laboratories—Other Changes

H. L. Willson, vice-president and general manager of the Columbia Graphophone Co., announced last month that E. N. Burns, formerly vice-president of the company and in charge of the Columbia recording laboratories, had severed his connections with the company. A. R. Harris, who was also connected with the Columbia recording laboratories, has resigned.

R. F. Bolton, one of the veterans of the Columbia organization, who has occupied numerous important executive posts in his many years of service, has been placed in charge of the recording laboratories temporarily.

John Brown, formerly comptroller of the Metropolitan Opera Co., and recognized internationally as one of the best-posted members of the musical world, has been placed in charge of the Columbia operatic and artist departments.

Frank B. Walker, formerly connected with the Central Concert Co., of Detroit, and well known in the musical field, is now associated with the Columbia recording laboratories.

MUSICO-PEDAGOGIC DISCOVERY

The value of the talking machine as a teacher, particularly in the household where a lot of youngsters hold forth, was demonstrated afresh in a story recently told by Henry T. Finck in the New York Evening Post, when he said:

"I know a boy of six who for four years has been running his own Victrola. Hundreds of times he has thus heard pieces of all kinds; but when he hums a melody to himself it is, nine times out of ten, a Strauss waltz! I regard this as one of the most important musico-pedagogic discoveries ever made. Parents, I say, if you want your children to become really musical, buy them records of the Strauss waltzes!"

PROUD OF HIS QUARTET OF GIRLS

HOLLIS, OKLA., November 1.—F. M. Keys, of the Spooner Hardware Co., Pathé dealer of this city, is doubly famous throughout the State for his excellent record in selling Pathé phonographs and also as the father of a quartet of wonderful and accomplished little girls—Roberta, Mona, Mary and Leota are all six years old—who are already Pathé enthusiasts.

The accompanying photograph depicts the young misses in the booth of the Harbour-Long-



F. M. Keys' Quartet of Daughters mire Phonograph Co., Pathé distributor of this city, at the State Fair recently held here. For the past few years the fond father of these quadruplets has had them at the Fair and their attendance at the Pathé booth has always attracted much attention and admiration.

The merchant who becomes discouraged and relaxes his efforts when times are dull may as well close his doors.

The Needle of The Century
A Near Permanent Needle

A CACTUS NEEDLE THAT SELLS ITSELF

Produces clear, natural tones; eliminates surface noise; brings out all subtle details of the music and preserves the records.

Needles can be repointed on sharpener enclosed in package, so that each needle will play an indefinite number of records.



ATTRACTIVE INDUCEMENTS MADE TO JOBBERS

For Samples and Particulars Write to

THE PERMO COMPANY
4215 TERRACE ST.,
OAKLAND, CALIFORNIA

MUSICAL INTEREST INTENSIFIED BY TALKING MACHINE

The Great Work Now Being Accomplished in Various Spheres of Musical Effort the Basis of a Splendid Tribute From the Pen of H. E. Krehbiel, of the New York Tribune

An increasing recognition of the talking machine as a supreme factor in the development of musical taste and appreciation in America has been especially discernible during the past two years, particularly among our leading musical critics. In the columns of *The World* we have printed from time to time editorials and articles taken from leading papers which emphasize this tendency and in the *New York Tribune* of recent date, under the caption "The Phonograph an Asset in the Spread of Musical Education," the following article appeared, from the pen of Henry E. Krehbiel, the dean of musical critics in New York—in fact, in America—and the author of many musical works of standing.

The points he emphasizes are not new to *World* readers, for we have been "pounding away" along these lines for the past ten years, but it is quite an achievement to have so notable a figure among the recorders of musical happenings so freely acknowledge the great field which is covered by the talking machine and the great work accomplished in musical and educational domains. The article follows:

"The development of the interest in music that has been so marked among all classes of the American people, especially since the World War, might have been retarded without the aid of the phonograph. Every one acknowledges the musical advance, whose echoes reach the ear at every turn and equally ready is the recognition of the part the phonograph has played and is playing in it. The little black discs have brought music, and the very best of music, into even the remotest corners of the earth, and have been a most effective agent of musical education.

"The phonograph has not confined itself to bringing cheer and comfort, musical knowledge and musical taste into the home. It has also found its way into the mill, the factory, the telephone exchange, the school room and the

library. Those who had anything to do with the entertainment of the soldiers in the camps, on the ships and behind the lines will not soon forget the service it performed in encouraging the depressed, soothing the nerve-racked and in general maintaining morale. Of course, these were really the services of music itself, but the phonograph, because of its comparative cheapness and its adaptability, was more generally chosen as the medium for these services than any other instrument.

"Cheapness, adaptability and all-around efficiency again account for the wide uses of the phonograph in industry, in education and in the hundred new spheres it has entered. It is a frequent and welcome visitor in the hospital ward. It sometimes accompanies the airplane pilot in his journeys above the clouds. It brings to the Indian on his reservation the songs of the white man and to the traveler in the desert the rhythms of his homeland. In the factory it has for years been used as part of the rest-room equipment, to refresh the worker after his toil.

"The latest convert to its usefulness is Uncle Sam himself. He is using it in his Minneapolis post office to assist the clerks in the sorting of the mail, and the experiment has been so successful that it probably will be extended to other post offices.

"Yet, for all this ubiquitous functioning, the greatest blessing the phonograph has brought remains its service in the home. Here it has made music lovers of hosts of men and women who never knew that they cared for music. The evolution of musical taste among phonograph owners is a phenomenon with which every music dealer is familiar. How often will a man who at first wants only dance records and syncopated melodies later demand a preponderance of classical songs and symphonic selections!

"Reflecting the all but universal use of the

phonograph in the home the instrument has invaded the classroom in the city and rural school house and is now as much a part of the paraphernalia of education as the blackboard and the reader. A comparatively new function it is performing is in connection with the music-memory contests or music-appreciation games which are being adopted all over the country to foster an acquaintance among children with the best in music."

STARTS SELLING CAMPAIGN

Columbia Dealer Carrying on a House-to-house Drive—Magnavox Concerts Proving a Source of Good Sales—Prospects Secured at Picnic

ELYRIA, O., November 6.—The Geo. A. Clark Co., of this city, Columbia dealer, has started a house-to-house drive with eight solicitors. Full-page advertising has appeared in the *Chronicle Telegram* and an effective window display, together with a Magnavox, has carried the news to passers-by. This "live" dealer recently staged a Grafonola Magnavox concert at Le Grange, O., and attracted the largest crowd ever gathered in the public square of that city. Two Grafonola sales, together with many valuable prospects, represented the direct results of this concert.

A few weeks ago the Geo. A. Clark Co. sponsored a Grafonola Magnavox concert at the Willys-Overland plant at the noon hour. Practically every employe in this vast plant was present and thoroughly enjoyed the concert. Three Grafonola sales were closed on the spot and the prospect list was enriched by a large number of names.

A church picnic was another means of getting further prospects for this active Columbia representative and, as a result of this concert, a K-2 Grafonola and a G-2 were sold, followed by the sale of an E-2.

To achieve what the world calls a success a man must attend strictly to business and keep a little in advance of the times.

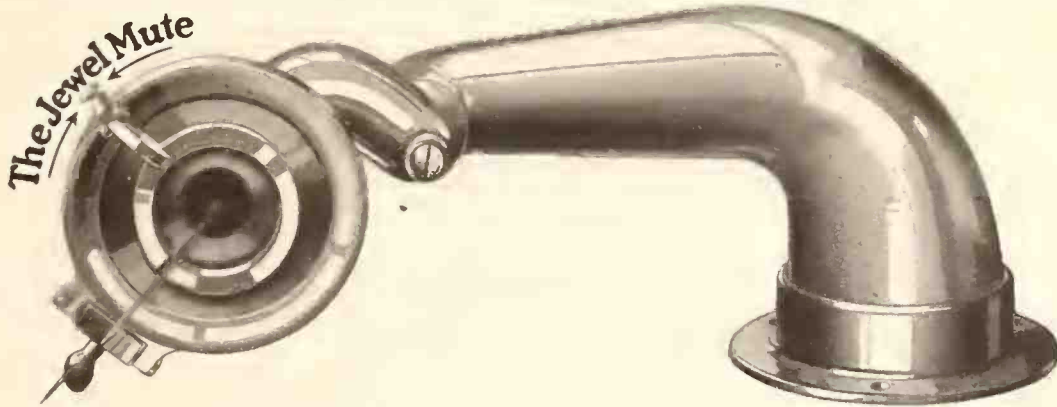

FEATURES

LARGE diaphragm and long stylus bar lengthens vibrations, producing a deeper and more natural quality of tone.

Perfectly balanced in accordance with carefully worked ratios and with regard to co-ordinate parts, this tone arm and reproducer permits a freedom and sweetness of tone heretofore thought impossible. Surface sounds almost entirely removed.

Throw-back design permits of easy access to needle socket. Saves records from unnecessary scratching.

PLAYS ALL RECORDS
No. 2 Round Tone Arm and Reproducer



KKNOWN the country over for its excellent quality of tone and natural, life-like reproduction of all musical tones, and its great volume. This tone arm on your machine spells success, because of its high standing in the Phonograph World.

Made only in 8½-inch length. Can be furnished with or without Mute Tone Modifier, with Mica or **NOM-Y-KA** diaphragm.

THE JEWEL MUTE

CONTROLS volume just like the human throat. Built in the reproducer and functions in such a way that the length of vibrations is minutely regulated and the tone reproduced to a softness and clearness that are remarkable.

Operates by means of a thumbscrew and is instantly adjustable. Tone has free and unimpaired passage throughout tone arm and chamber—Not "Muffled" or "Choked" as with ordinary type of tone modifier.

Perfect regulation without in any way changing character of tone.

JEWEL PHONOPARTS COMPANY - 154 W. Whiting St., Chicago

Promise and Performance



Queen Anne Console

Granby Dealers have faith in the Granby institution and its product.

These Dealers know that the Granby Phonograph Corporation has rigidly lived up to every promise, and more.

Granby Phonographs have come up to expectations in every particular.

The Granby selling policy is sound. It means substantial profits to Granby Dealers.

If you do not handle the Granby, you cannot appreciate what this means to you.

Profit by the experience of the Granby Army of Merchants. Get the full story by return mail today.

Send the coupon—TODAY.

GRANBY PHONOGRAPH CORPORATION

LEVY BUILDING

☒ N O R F O L K - V I R G I N I A ☒

Tear off Coupon—Sign—Mail TODAY

I shall be glad to receive the Granby proposition.

Name

Address

City

State

Planning an Especial Appeal for Juvenile Record Trade During the Holidays

By W. B. Stoddard

For a number of seasons—in fact, ever since the original talking machine was placed on the market—much attention has been paid to featuring records for adults for the holidays, but it is only recently that a real effort has been made to give publicity to the fact that juvenile records make a gift to delight all the kiddies. The youngsters have their miniature wash tubs, doll beds, trains of cars, tool sets—why should they not have their own music? A very practical appeal to the adults can also be made for the purchase of these records. All children love to play records, and many a fine one has been damaged by the careless handling of the little ones. By getting them a popular-priced machine and a supply of their own records they will be just as happy, and the Kreisler and Galli-Curci records will be safe. These juvenile records also furnish much amusement for rainy days, and those of the Bubble Books, especially, offer wide scope for childish amateur theatricals.

Several stores in different parts of the country have seen the value of giving publicity to this angle of the trade and have arranged children's parties in order to interest the youngsters in these records.

The J. D. Palmer Store, Marshalltown, Iowa, announced recently that the first one hundred children, accompanied by their mothers, registering at their store on a certain day would be presented with photographs of themselves free. So large a crowd attended that the doors had to be closed. An order on a local photographer was given to the first one hundred, as per the advertising. Then, as a consolation prize to the hundreds of others, the entire gathering was treated to a Mother Goose Show in the large auditorium on the second floor, the characters from the Bubble Books appearing in person, singing the songs made popular by the records. At the conclusion of the concert Little Boy Blue, Jack and Jill, Mistress Mary and Mother Goose passed down among the crowds and distributed souvenirs—little books containing several of the songs—with a statement that the records were on sale at the store. Just before the big party broke up a photographer appeared on the stage and took a picture of the crowds of children, and this was enlarged and later exhibited in the windows of the store, surrounded by an arch made of the juvenile records.

Yunker Bros., Des Moines, Iowa, made a big hit with the children and parents by staging a Bubble Book party for the little folks. All children were invited to come and "bring your mother, too," so there was a big crowd on hand at the appointed hour. Juvenile elocutionists recited for the audience, while the Bubble Books themselves were the star performers. The store had filled one of their large windows with these books and on the afternoon of the concert these were carried to the concert room in armfuls, where the records of all the different books were played. In addition, pipes and pans of soap suds were distributed, so that real soap bubbles were a part of the highly enjoyable bubble party. The window just mentioned showed a popular-price

Some Suggestions That Will Help Dealers in Perfecting Means of Appealing to Children in Their Territory

machine on a wicker stand, with several records standing on top of it. On tables, chairs and on the floor were quantities of the Bubble Books, some open, some closed. Several drapes of crimson-and-gold velvet were used, and on these were placed a number of juvenile records taken from the books.

Believing that first impressions are lasting, the Golden Rule Department Store, St. Paul, Minn., laid great stress on the attention paid the little folks who attended their Bubble Book parties recently. A trained corps of ushers took the hundreds of little ones in charge as soon as they entered the store, escorted them to the elevators and then to their seats in the auditorium on the fourth floor. Six hundred tickets were given out on each of the four days when the performances took place. Characters from the Bubble Books

were taken by children from a local school of dancing, sixteen little folks taking part, while the part of Mother Goose was taken by one of the sales force. A special feature of the performance was the Bubble Dance performed by one of the little pupils.

Lord & Taylor held Bubble Book parties on three successive Saturday afternoons in November, the entertainment consisting of a pantomime by thirty children, each impersonating a character from a childhood classic, such as Little Bo-Peep, Jack and Jill, Goldilocks, Queen of Hearts, etc. The selling value of these entertainments was enhanced by the big announcement appearing in their ads, which stated that the children who saw the show could reproduce it, or similar ones, at home for themselves. A colored poster, announcing the parties and stating that tickets could be procured at the music department, was hung in several of the display windows.

BIG SCOPE TO RED SEAL RECORDS

Not Confined to Purely Classical, Says C. A. Womeldorff—Educate Sales Force and Public

TOLEDO, O., November 6.—C. A. Womeldorff, president of the Toledo Talking Machine Co., returned recently from attendance at the distributors' school of the Victor Co., at Camden, N. J. Mr. Womeldorff was particularly impressed with the possibilities of developing popular appreciation of the Red Seal records, which to many people mean purely classical or "operatic" selections only.

This is a misconception which Mr. Womeldorff believes every Victor man and woman should endeavor to correct, as Red Seal records are very often songs and selections of the "popular" variety. He is further urging that dealers and record sales people in his territory remember that there is not a Red Seal record of which the customer cannot be told something very interesting—either of the musical value of the number itself or the recording artist.

Bill's Art and Novelty Shop, of which Wm. E. Revier is proprietor, has taken over the Northfield, Minn., agency for the Victrola. He has arranged very handsome quarters, equipped with Selrex record demonstrators.

TONE ARMS for Portable Machines

TONE ARMS for Medium Priced Machines

TONE ARMS for High Grade Machines

Quantity prices from \$2 up, including sound box

Will make specially designed tone arm and sound box if quantity warrants

Let us know your requirements and we will quote you prices

The William Phillips Phono Parts Corp.

145 West Forty-fifth Street

New York City



Many extra Christmas sales will reward the dealer who uses the Columbia Christmas Gift Envelopes for Columbia Records. Let Columbia service make your store a gift shop.

Columbia Graphophone Co.
NEW YORK

PATHE OFFICIALS ARE ACTIVE

President W. W. Chase Now in California—A. W. Copp Has Vice-presidency Added to List of Offices—News of the Travelers

W. W. Chase, president of the Pathé Frères Phonograph Co., Brooklyn, N. Y., is now in California, accompanied by Mrs. Chase. President Chase's itinerary includes Chicago, Denver, Portland, Seattle, Indianapolis, Omaha and other jobbing centers.

A. W. Copp, treasurer and purchasing agent of the Pathé Frères Phonograph Co., has also been elected to the office of vice-president, retaining his other duties as well. Mr. Copp is a highly trained executive and is widely known in financial circles. He was formerly contract manager of the Thompson-Starrett Co. and his executive ability is proving of much value in the Pathé organization.

James Watters, secretary of the company, is at present on a trip in the interest of the Pathé, covering Chicago, St. Louis, Oklahoma City, Dallas and Nashville.

O. M. Keis, field supervisor of the Pathé Frères organization, who has been studying retail conditions in Indianapolis during the last three months, has made his report and has been taking a short rest at Williamsport, Pa.

Earl B. Dryden, of the sales force, has made his headquarters in Denver, Col., and is increasing Pathé sales to a noticeable degree within the radius of that city.

Frank Capps, factory manager, has appointed F. L. McCarty in charge of the many duties of that important position, but will continue general supervision.

C. H. Murray, assistant to the president, reports that business has very greatly improved and is entirely optimistic over future conditions in the trade.

CHARLES R. TIGHE, JR., MARRIED

Member of Talking Machine World Staff Marries Miss L. E. Petsche, of Yonkers, N. Y.

Dan Cupid has been a busy little body this Fall and among those in our immediate neighborhood stabbed with his sharpened dart was Charles R. Tighe, Jr., a member of the staff of The Talking Machine World, who was married on October 14 to Miss Louise Elizabeth Petsche, daughter of B. William Petsche, of Yonkers, N. Y. The wedding was a quiet one, only the immediate members of the families of the bride and groom being in attendance. After a honeymoon trip, which was spent at various Southern resorts, Mr. and Mrs. Tighe are making their home in Yonkers. The happy couple have the best wishes of The World staff for their happiness.

Lord Fisher says there are four things for a Big Life: first, a great inspiration; second, a great cause; third, a great battle; fourth, a great victory.

PROVIDE MUSIC BY RADIO

The Youngsters Around New York Indebted to "W. J. Z." for His Supply of Music and News

An interesting story of a radio fan who, unsolicited, gets in touch with a large constituency of eavesdroppers who have rigged up wireless equipments is thus related by W. B. Haywood in the Evening Post:

"Our next selection, says the announcer, will be a record of the 'Blue Danube Waltz,' played by the Marimba Band. A moment of silence, the Marimba Band strikes up, and the music finds its way into the telephone receivers of a thousand small boys, who have rigged aerials in the backyard from chimney to tree and expect one day to astonish the world with their discoveries in the field of radio transmission.

"If anyone has a shadow of doubt about the wireless telephone and the voices that float through the air of the metropolitan district, let him listen to W. J. Z. The initials represent his call number, not his name. W. J. Z. is the genial chap who sends out phonograph concerts every night from the radio telephone station of the Westinghouse Electric & Mfg. Co. in Newark, not to speak of baseball, play by play, and general items of news, including the Government weather and agricultural reports.

"His musical numbers range from jazz to opera. He has bedtime stories on tap for the children and each piece on the program is announced clearly by W. J. Z. himself. Whether or not he knows it, he has made himself the firm friend of all the world of budding radio operators living within ten miles of Newark, N. J. One does not have to learn the Morse code to interpret W. J. Z. He speaks English, though some of his music was written by Frenchmen and Italians. At one time in his career he must have attended a school of elocution, for one cannot misunderstand him, even if the wireless receiving set one uses represents an outlay of less than twenty dollars.

"If any parent wants to know how to keep Johnny amused in the evening just have him contract the radio fever, which has become quite as prevalent as measles in the vicinity of New York, and involves no doctor's bills, unless Johnny is out of luck and breaks an arm while climbing the ailanthus tree to rig up his aerial."

FOR THE MAN WHO WANTS TO SELL

Don't argue—illustrate.—Don't ever tell a prospect that he is mistaken.—Don't wear anything to attract or concentrate the eye of the prospect on your dress.—Don't ask the prospect a question to which he can say "No."—Don't talk price; talk quality, though your price is low.—Don't run down the other fellow's goods; talk the reason why of your goods.—Don't say anything against the goods on which the prospect looks with favor, for you will offend his judgment, on which every man prides himself.

T. M. Shurer has opened up a phonograph record exchange in Sheboygan, Wis.

"EXPERIENCE"

To Our Customers We Owe All—To Them We Give All

Our many years of experience in the merchandising of Victor

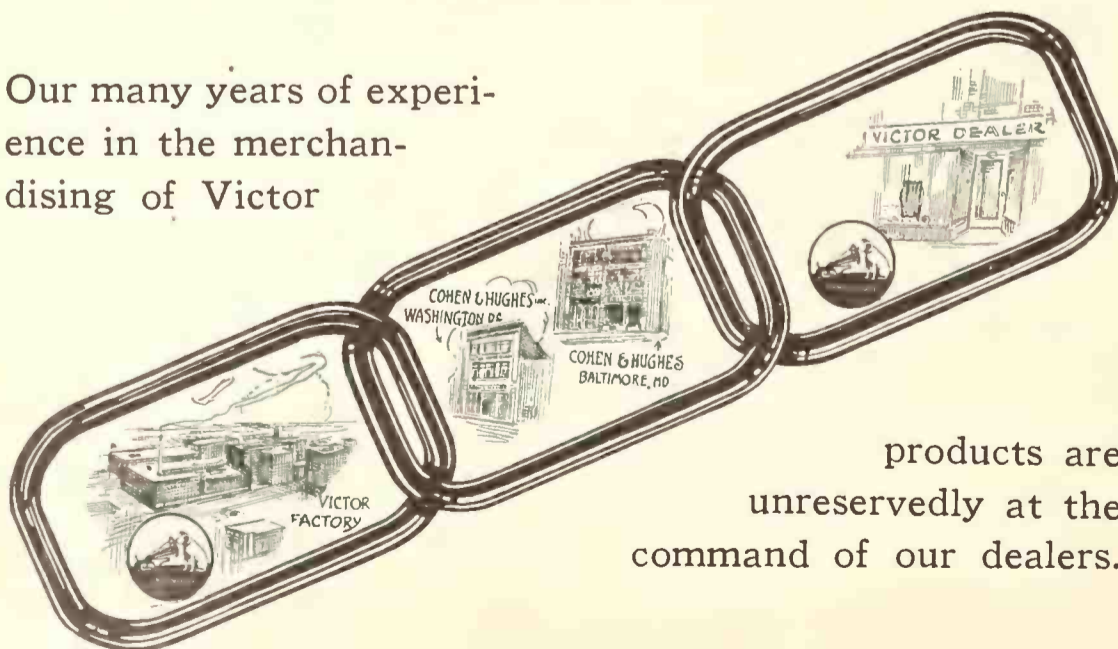

products are unreservedly at the command of our dealers.

COHEN & HUGHES

Wholesale Exclusively

BALTIMORE

WASHINGTON



This is a Sample of the Support Brunswick Dealers Get

The above Double Page Spread will appear in *The Saturday Evening Post* of December 3. It is the seventh of a series of spreads this year to help dealers sell more Brunswick Phonographs and Records.

Note that this one is a multiplied retail advertisement. It will benefit every Brunswick dealer, wherever located.

A "Brunswick Christmas Shoppers' Guide" Special Christmas List

The following special list of records, which everybody wants during the holiday season, will appear in this double spread, a timely suggestion to the Christmas buyer.

- | | |
|---|--|
| <p>10046—Silent Night (Gruben) Soprano
Florence Easton and Male Trio</p> <p>2148—Hark! The Herald Angels Sing... All Souls' Choir
It Came Upon the Midnight Clear
Cathedral Choir</p> <p>2149—White Shepherds Watched... All Souls' Choir
Angels From the Realms of Glory
Cathedral Choir</p> <p>10045—Holy Night (Adam) Tenor
Mario Chamlee and Chorus</p> <p>30011—Ave Maria (Soprano and Violin) In Latin
Florence Easton and Max Rosen</p> <p>5032—Night Before Christmas (Recitation)
Ernest Hare</p> <p>"De Sandman" (Protheroe-Griffin)
Criterion Male Quartet</p> <p>5001—Wayside Cross (Palmer) Criterion Male Quartet
Church in the Wildwood (Pitts)
Criterion Male Quartet</p> <p>13002—Christ in Flanders (Stephens) Tenor Theo. Karle
The Lord Is My Light (Allitsen) Tenor
Theo. Karle</p> <p>5033—Adeste Fideles (Oh, Come All Ye Faithful)
(Portugal)... Collegiate Choir
Joy to the World (Handel)... Collegiate Choir</p> | <p>5043—Saw Ye My Savior (Eddy-Brackett) Baritone
Lloyd Simonson
Shepherd, Show Me How to Go (Eddy-Brackett)
Baritone... Lloyd Simonson</p> <p>5017—Abide With Me (Monk) Soprano and Contralto
Marie Tiffany and Elizabeth Lennox
Almost Persuaded (Bliss) Soprano and Contralto
Marie Tiffany and Elizabeth Lennox</p> <p>5022—Angel's Serenade (Braga) Soprano Marie Tiffany
Cradle Song (Brahms) Soprano... Marie Tiffany</p> <p>5000—Whispering Hope (Hawthorne) Soprano and Contralto...
Ida Heydt and Elizabeth Lennox
Oh! Dry Those Tears (Del Riego) Contralto
Elizabeth Lennox</p> <p>5039—Christ Arose (Lowry)... Collegiate Choir
Come, Thou Almighty King (Wesley-Giardini)
Collegiate Choir</p> <p>13007—Bells of St. Mary's (Adams) Tenor... Theo. Karle
Evening Song (Blumenthal) Tenor... Theo. Karle</p> <p>2054—Kiddies' Patrol (Rogers)
Brunswick Concert Band
Kiddies' Dance (Rogers)
Brunswick Concert Band</p> <p>5041B—Cradle Song (MacFadyen) Contralto
Elizabeth Lennox</p> |
|---|--|

Brunswick Records Can Be Played on Any Phonograph

Sixteen Models Illustrated

In the same spread all sixteen Brunswick Phonographs—Cabinets, Consoles and larger period designs—are pictured. There is a Brunswick in a size and style and at a price to suit every home. Prices from \$65 to \$775.

THE BRUNSWICK-BALKE-COLLENDER CO.

General Offices: 623-633 S. Wabash Ave., Chicago

Branch Houses in Principal Cities of United States, Mexico and Canada

New England Distributors:
Kraft, Bates & Spencer, Inc.,
1265 Boylston Street, Boston, Mass.

Canadian Distributors:
Musical Merchandise Sales Co.
79 Wellington St., West, Toronto

The Brunswick-Balke-Collender Co.,
1a La Calle de Capuchinas No. 25
Mexico City, Mexico

Brunswick

PHONOGRAPHS AND RECORDS





IROQUOIS SALES CORPORATION
BUFFALO, N. Y.

Wholesale Distributors



Okeh Records

NOVEMBER OKEH DISPLAY

Thanksgiving Festivities the Keypnote of Okeh Window Display for November

The Okeh display for November is one of the most colorful and brilliant displays Okeh has issued for some time past. Its central thought and, in fact, the entire display, is built around Thanksgiving.

The Okeh November display has taken full advantage of the true spirit of this holiday and



Okeh Window Display for November

portrays Thanksgiving in the time of the Pilgrims and to-day. The center panel shows the Pilgrims in their stockade feasting and a harvest atmosphere lends brilliant color and a pleasing effect. The main illustration depicts Thanksgiving at the old homestead, with all the family reunited for this real old-fashioned celebration. The other units carry out the central thought appropriately, featuring titles of some of the month's best sellers.

IMPROVED CONDITIONS IN SOUTH

E. A. Schroder, the Southern traveling representative of the Peerless Album Co., New York, recently returned from an extensive trade trip and will confine his sales activities to Eastern territory during the balance of the year.

Mr. Schroder states that conditions in Southern sections of the country have improved materially during the past few months and indications are that the trade in the South is to be quite active during the holidays.

There are two things that menace the prosperity of this country—idle money and idle labor. The one is as mischievous as the other.

ADVERTISING FOR THE HOLIDAYS

If Console Types Are Featured It Will Be Best to Devote Some Space to Other Styles Carried by the House in Order to Broaden the Appeal

Around the holiday season dealers usually make more than ordinary efforts in the way of publicity. It is always a mooted question how best to advertise and how the dealer may present his products so as to best attract the attention of the purchasing public. The question arises: Is it best to concentrate on one style of talking machine or advertise the full line?

There are those who believe that concentration on one line is best. For instance, at the present time a number of dealers are devoting considerable space, and very properly, to the console types of talking machines which are now so greatly favored by the purchasing public. It must be remembered, however, that there is a large army of prospects who cannot afford to buy machines as high priced as the console type. Therefore, the dealers advertising should make a wider appeal by also bringing to the notice of

prospective purchasers the values to be found in the various lower-priced floor or table styles of instruments.

The console types could be featured, in other words, the major space in the advertisement could be given to these instruments, but space should also be given to the fact that other instruments are handled at lower prices, so that there is no possibility of the reader being under the impression that his needs, whatever they may be, cannot be satisfied.

J. E. HALPERN A BENEDICT

J. E. Halpern, metropolitan sales manager for the Peerless Album Co., New York City, was recently married to Miss Miriam Glass. The young couple are making a honeymoon trip through Southern territory by way of Atlantic City, N. J. Washington, Baltimore and other trade centers are to be visited.

Success is the accomplishment of any one task as well or better than the same task can be accomplished by another.

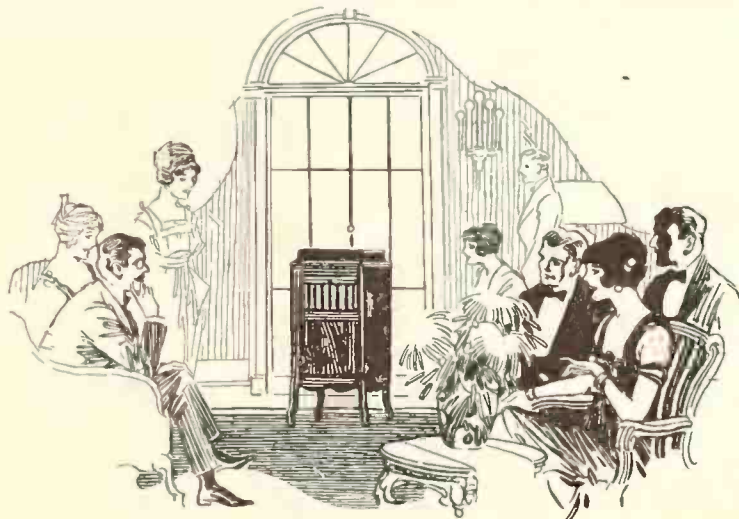

It's easier to sell a phonograph made of Genuine Mahogany

WHY do they prefer Genuine Mahogany?

Because a Genuine Mahogany phonograph is more than just a phonograph—it is a beautiful piece of furniture. Genuine Mahogany has an air of distinction which harmonizes with the most luxurious and tasteful furniture.

Genuine Mahogany lends itself especially well to those graceful designs which characterized the artistry of Chippendale, Sheraton, Heppelwhite and other master cabinet makers. In fact, without exception, each of them chose Genuine Mahogany as the wood in which he could best express his art and craftsmanship.

Whether it be the beautiful expensive period design or the more modest model, the rich coloring and lasting beauty of Genuine Mahogany make it a cherished addition to any home.

The Mahogany Association is cooperating with phonograph manufacturers and dealers to aid the purchaser in his desire to obtain Genuine Mahogany. An increased interest and demand for the "royal wood" is already apparent.

After all—there's nothing like

MAHOGANY

MAHOGANY ASSOCIATION, 347 Madison Avenue, NEW YORK



Phonographs of uncommon value and unusual sales co-operation

IF that is the kind of instruments and kind of factory which interest you, let us hear your wishes. Some most desirable territory is yet available. Our dealers are virtually our *partners*: so regarded, and so treated.

The Dalion is a well-rounded line of instruments that for actual, intrinsic value and true tone worth are not excelled in the field. Back of it all is a progressive sales policy that is pushing all the time. Why don't you investigate the very real advantages our selling franchise offers? Write that letter *now!*



Have you ever read the Dalion Guarantee?

Every Dalion is warranted not only against all imperfections of material and workmanship, but as a musical instrument second to none in fidelity of reproduction, and the motor is so good it is guaranteed against spring breakage for one year.

Are phonographs a department with you—or a *business*? We invite inquiry from dealers who want to build volume and profit in this field.

MILWAUKEE TALKING MACHINE MFG. CO.

Milwaukee, Wis., U. S. A.

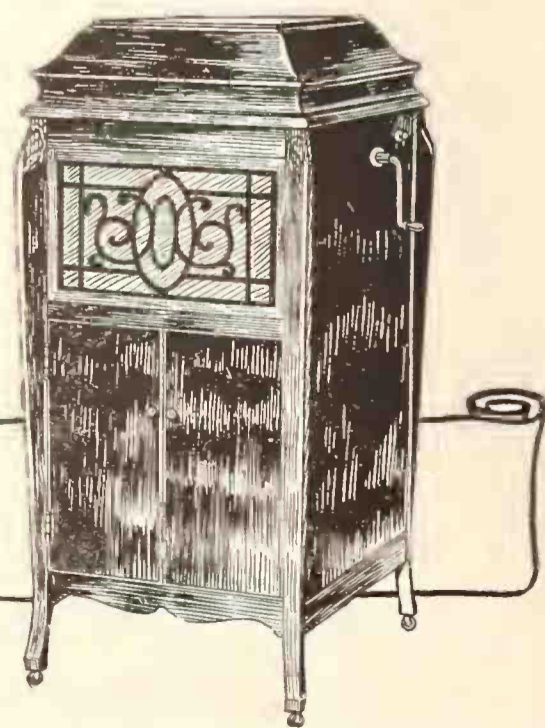

How Best to Transform the Thanksgiving Spirit Into Talking Machine Sales :: By Thornton Hall

In a week's time will come a holiday that is too often overlooked by talking machine merchants—Thanksgiving Day. There are certain aspects of this holiday that can be turned into profit by the dealer who is alive to them. It has long been a matter for wonder that the dealer who will create more or less of a merchandising fuss over Halloween from a business viewpoint and who goes after Christmas season business in a big way will pay absolutely no attention to the potential profits of Thanksgiving.

There are dealers, however, who do include this Thanksgiving season in their merchandising plan and program. Suppose we draw briefly from their experiences for the benefit of those dealers who still have time to cash in on the 1921 Thanksgiving trade.

Thanksgiving can be exploited in many phases of retail sales promotion. The work of all departments can and should be included. The sales forces, the window trimmers, the book-keeping and collection departments, the advertising manager, even the delivery force should be made to recognize the value of Thanksgiving as an extra sales booster. While it is the window trimmer who is naturally thought of first in connection with holiday promotion work, perhaps we can show how the Thanksgiving link-up can be made effective right down the line.

Utilizing the Display Window.

The street window is the most important display spot in the talking machine store. It is here that the merchant flags the passing prospect and gets his idea across to him. In this case the message is something like this: "Stop. Thanksgiving is coming. Let me tell you why Thanksgiving should cause you to buy a talking machine and records. Come in." In other words, the window display should get over to the prospective customer the idea of the association of Thanksgiving and music—particularly talking machine music.

Dealers should, of course, make use of the excellent lithograph window trims appropriate to Thanksgiving usually supplied by the manufacturer. These are always helpful, but even more helpful are windows which carry out an idea of the dealer's own. This gives an impression of being alive and on the job, even to the casual observer. People like to trade with stores that impress them as being progressive. Last year a certain dealer of this type transformed his show window into a Thanksgiving banquet scene, with a long table set for a large family and heaped with typical Thanksgiving foods. All the "fixin's" were there—a turkey, cranberry sauce, everything. Over in the corner in a promi-

nent position was a large cabinet model talking machine bearing a large card, with the legend: "The Guest of Honor," and a streamer leading to a window sticker which read:

"MORE IMPORTANT THAN THE BIRD HIMSELF for the success of the Thanksgiving dinner is a.....Talking Machine. Make sure you've provided for the Music with the Meal."

Another window trim which suggests itself for the Thanksgiving holiday has to do with pushing the sale of Caruso records. The Thanksgiving effect can be secured by means of a background of cornstalks, pumpkins, etc. In the foreground on the left place a mourning-draped photograph of Caruso and at the right a poster listing all of his records that you have. Let a third poster read:

A REAL CAUSE FOR THANKSGIVING
The voice of Caruso will live forever.

Capitalizing an Old Familiar Stunt

The sales department can make use of an old familiar stunt which has been often used with great success in other fields. This is the Thanksgiving turkey raffle, always popular with the public, which dislikes to admit its inherent love for getting "something for nothing." Simply give a number to each record which is sold for a certain number of days before Thanksgiving Eve. Let these numbers be dropped in a box and a good, fat turkey be given the holder of the lucky number. It is a safe guess that many extra records will be sold to get those extra chances at winning the bird. Later you have the chance for a "human interest" story in the papers on the title of the selection whose number was the winning one, which will be good publicity.

Another means of keeping alive interest in the Thanksgiving sale of records is the taking of a poll of customers as to the selection most appropriate to Thanksgiving. The mind of the public is fairly well fixed on Christmas and other holiday music and people will be interested to discover the popular sentiment about Thanksgiving music. A record can be given to the person first choosing the most popular title.

A clever idea is used by one dealer each year just before Thanksgiving Day. When sending out the November statements he has the statement clerk put all statements of overdue accounts to one side. On each of these he affixes a sticker which reads:

THANKSGIVING DAY, November 24.—One of the things we hope to be thankful for is the settlement of the attached account.

This tactful reminder will in a great many cases smooth over an embarrassing item, for it is a form of "dun" that sacrifices none of the customer's good will.

The on-the-job dealer has a list of live prospects which he circularizes at least once a month. Here is a timely letter that works in the Thanksgiving idea:

Dear Mr. Prospect:—It is a wise custom that decrees the setting apart of one day each year for Thanksgiving. You and I will no doubt receive a substantial moral benefit next week through the medium of a few moments' reflection on the goodness of Providence.

Among the things I am thankful for is the ever-growing love for music among the citizens of this community. The wide popularity of the talking machine is in a large way responsible for this educational boon to mankind.

If you desire to secure your.....talking machine before Thanksgiving, you will be thankful all the rest of the days of your life. Sincerely yours.

Another dealer even works his delivery department into his Thanksgiving program of sales promotion. He has a fleet of Ford delivery trucks and a week before the holiday he decorates them with a canvas sign reading:

STORE CLOSED ALL DAY THANKSGIVING DAY.

Open for your convenience until 10 Wednesday evening. Arrange for your holiday music now.

This same dealer also turns over two of these trucks to the use of a local charitable organization in distributing Thanksgiving turkeys and food to the poor for a few hours on the preceding Wednesday.

The advertising department will find it more beneficial in the long run to devote its contract newspaper space during Thanksgiving week to the "good will" or institutional type of advertisement. Topics adaptable for advertising copy are "The History of Thanksgiving," "The Meaning of Thanksgiving" and "Thanksgiving and Music."

It is the belief of the writer that by exercising his ingenuity the dealer can make use of the Thanksgiving "motif" in every department. It is this tying-up of a central idea among all departments that is responsible for the notable success of a great many retail institutions and there is no time like the present to adopt its use.

INCORPORATED IN WEST VIRGINIA

The Beckley Phonograph Co., with a capital stock of \$15,000, has been incorporated in West Virginia by C. M. Ward, T. C. Moorefield, C. G. Casto, French Lucas, D. B. Jarrell and others.

WHOLESALE



DISTRIBUTOR

WHERE Service to Victor Dealers is Backed by Long, First-hand Experience in the Field of Distribution.

EMANUEL BLOUT

VICTOR EXCLUSIVELY

2799 BROADWAY, at 108th Street, : : : NEW YORK

**PETMECKY
NEEDLES**

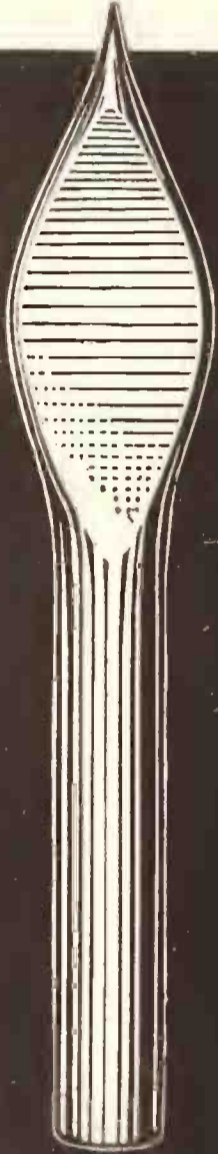

CAUTION

THE only genuine Petmecky (combination tone) needles in the U. S. are manufactured by W. H. Bagshaw Co. Each Genuine Petmecky needle will play ten records and produce loud, soft and intermediate tones, by a change of position on the record. Owing to their peculiar construction, Genuine Petmecky needles are self-sharpening, improve the tone quality and prolong the life of the record.

A comparison with imitations, regardless of their name, will reveal that only Genuine **PET-MECKY NEEDLES** have the characteristic shape and produce the even tone throughout the running of 10 records.

W.H.BAGSHAW CO.

FACTORIES: LOWELL, MASS.

SELLING AGENTS

BRILLIANTONE STEEL NEEDLE CO. OF AMERICA
INCORPORATED

347 FIFTH AVENUE

AT 34th STREET

NEW YORK

SUITE 610

On With The Dance!

LET SALES BE UNCONFINED



The Very Latest Dance Records of

Isham Jones

Paul Whiteman

Art Hickman

The Finest Dance Music in the World

Only the finest DANCE NEEDLES in the world can do justice to these master-creations. Brilliantone Dance Needles are the supreme product of the oldest manufacturer of steel talking machine needles in America. When you sell Brilliantone Dance Needles to your customers you insure complete satisfaction—and thereby you sell more dance records!



(The Oldest and Largest Manufacturers of Talking Machine Needles in the World)

BRILLIANTONE
STEEL NEEDLE CO. of America,
 Incorporated

Selling Agents for

W. H. BAGSHAW & CO. Factory, Lowell, Mass.

AT 34th STREET **347 FIFTH AVENUE,**
NEW YORK SUITE 610

Canadian Distributors: The Musical Mdse. Sales Co., 79 Wellington St. W., Toronto
 Foreign Export: Chipman Ltd., 8-10 Bridge St., New York City



This month's novelty is an airy-fairy coupling by the Gypsy String Quartet. You know how persuasive gypsies are in a trade. They'll persuade many extra dollars into your store with "Dreams and Fairy-Tales" and "Fiora"—E-7304.

Columbia Graphophone Co. NEW YORK

VICTOR DEALER ACTIVITY IN IOWA

Iowa Victor Dealers Are Closing Healthy Business—Many New Establishments Opened—Mickel Bros. Report Renewed Confidence Throughout Territory—News of Month

DES MOINES, IA., November 7.—The Victor situation throughout the Corn State during the past month has shown a decided improvement. During July and August the talking machine business in general was very poor, but commencing about September 15 the dealers were optimistic enough to commence preparing their stock for an anticipated business. While corn still remains around 30 cents in price the farmers have been compelled to sell some of their reserve in order to take care of the urgent demands of the banks that loans be reduced as rapidly as possible.

H. B. Sixsmith, sales manager of Mickel Bros. Co., Victor wholesaler, speaks in very encouraging terms of the month's business. "Our business," said Mr. Sixsmith, "is remarkable considering the prevailing talk of 'no business.' Our dealers believe with us that, while the holiday season may not be as good as last year, we still look for intensified buying as the season draws to a close. The dealers are evidently of the same opinion, as practically all of the larger accounts have purchased a reserve stock of about the same size as last year. Our collections have

been exceptionally good. Iowa is essentially a corn State, and as its price has been so low for such a length of time very few farmers have shipped anything to market. It is becoming more of a common thing to see the roads dotted with loads of corn now, as the harvesting of the present crop has undoubtedly induced the farmer to move some of the 1920 stock, regardless of price."

E. P. Shellabarger, of Columbus Junction, attended the Victor convention held in Des Moines last month. He had arranged to become a Victor dealer in October, but after hearing John Gregg Paine speak on the possibilities of the line, insisted that his initial stock be delivered at once.

The Red Cross Drug & Jewelry Co., of Nashua, has just become a Victor dealer. It has already installed a large department, consisting of a demonstrating room and a complete stock of Victrolas and Victor records.

Geo. E. Mickel, president of Mickel Bros., recently attended the wholesalers' school at Camden, N. J. "Never too old to learn" is Mr. Mickel's motto.

The F. H. Drew Co., of Cedar Rapids, stated that it sold \$587 worth of needles during 1920. Profits on this item more than paid its light bill.

C. E. McLeran, of Mt. Pleasant, worked a very successful scheme with the New Records magazine. He mailed out 800 with a postal which contained a number of questions pertaining to

whether or not a talking machine, piano or any other musical instrument was owned, and if they liked the magazine they should sign and return the card to him. Out of the 800 magazines he received orders for ten Victrolas.

The Tucker Furniture & Carpet Co., of Clinton, is arranging to move its Victor department from the balcony down to the first floor. A complete battery of booths, record racks and complete Victor stock will soon be offered to the people of Clinton. Miss Margaret Johnson is in charge of the department.

A number of the Iowa dealers are putting on the famous selling stunt of the West, the "Mickel Victrola Club." The plan started in Omaha a number of years ago and another successful club went down in history during September. The costs of the month were about \$1,700 and the net business secured was about \$16,000. Besides this twenty-seven pianos, of which twelve were grands, were sold. Wm. Mickel is responsible for these wonderful results.

Thiel & Lambach, of Tipton, have just taken on the complete line of Victrolas and Victor records. Unfortunately, that point has been without representation during the past year, owing to the fact that a satisfactory dealer could not be obtained. With the installation that this concern is putting in the line will soon have a fine representation there.

The Lippert Jewelry & Music Co., of Dyersville, Ia., is busy conducting a musical census of that section of the country. Mr. Obert, the manager of the department, states that the results are astonishing.

The Watters Drug Co., of Cedar Falls, has practically closed negotiations with the Iowa State Teachers' College at that point whereby a Victrola will be installed in every department in the college. Prof. C. A. Fullerton has charge of this department at the college.

GRANBY CAMPAIGN IN ST. LOUIS

St. Louis, Mo., November 4.—Sunday, October 16, was Granby Day in this city. The local newspapers ran large Granby ads and coupled with this excellent newspaper publicity was a series of elaborate window displays at the various locations of St. Louis Granby dealers. Those partaking in this impressive campaign were: The Buettner Furniture Co., Widener's, Inc., H. F. Geitz Co., David's Furniture Co., Tower Music Shoppe and the Deeken Music Co. In addition to the energetic work of the various Granby dealers much credit is due E. W. Schumaker, who represents the Granby Phonograph Corp., of Norfolk, Va., in this city, and who carried out all the details of the campaign.

Albert Skillim has been appointed manager of the Victor department of the Otis Skinner Optical Co. in Bangor, Me. This establishment conducts one of the largest and best-equipped Victor departments in the State.

Mistakes are inevitable. We all make them, but they should never be made more than once.

—AN EFFICIENT ORGANIZATION OF IOWA EXTENDING MICKEL SERVICE—

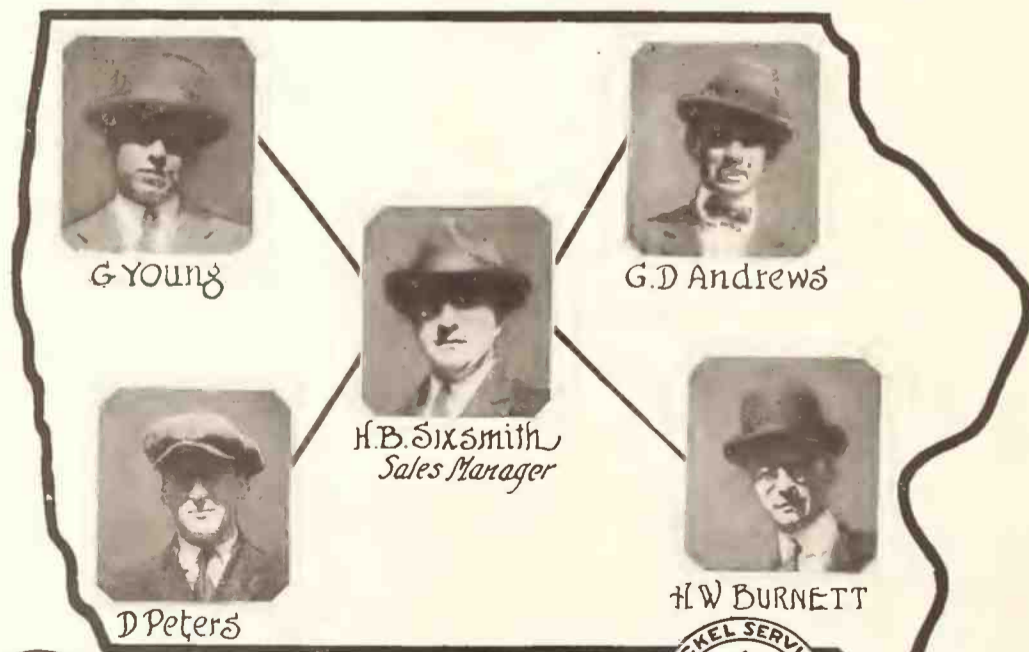

MICKEL BROS.

"MICKEL BLDG."

DES MOINES... COMPANY.....IOWA.....

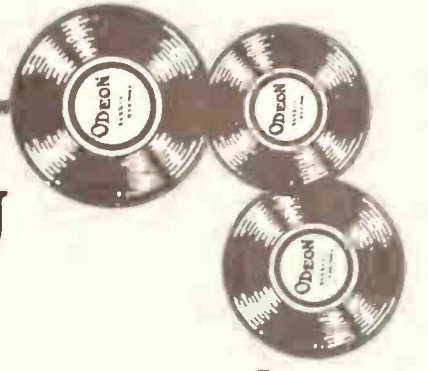

PROFITS FOR YOU

Anticipate Your

XMAS REQUIREMENTS

Prepare Your Stock for the Rush

Santa Claus Hides in the Talking Machine



Holy Night, Silent Night. — Hark, the Herald Angels Sing



Under the Christmas Tree

(Descriptive)



Stille Nacht, Heilige Nacht



O Du Fröliche, O Du Selige Weihnachtszeit



Gypsy Blues



Thrills



Everybody Step



Frankie



Sweet Lady



Many Other Excellent Hits

FOREIGN LANGUAGE RECORDS

CELEBRATED ARTISTS' SELECTIONS

ON

ODEON

and

FONOTIPIA

RECORDS

ASK FOR OUR CATALOGS

An Excellent Proposition for High-Class Distributors

American Odeon Corporation

100 West 21st Street Phone Chelsea 0286-0287 New York



Phonographic Epigrammatics

By
HAYWARD CLEVELAND

Smile, smile always! A smile costs no more than a frown. Besides, you have a reason. You are in the Uplift Business, trying to make the world happier!

The difference between success and failure in anything is almost always a matter of one more effort. Keep eternally at it!

Be sure that more business does not go out of the door unharvested than comes in through it unsolicited!

Play the verse through. Do not obtrude your talk. It distracts—is rude. You would not think of interrupting the living singer, would you?

Napoleon said: "The good Lord is always on the side of the heaviest artillery," but he did not mean by this "Loud-est at the mouth!"

A "TIMELY" WINDOW SUGGESTION

Talking machine dealers who sometimes run up against a stone wall in the matter of attracting the public to their window displays may utilize the following idea with some degree of success: Place a number of alarm clocks with the dial facing the street in the window, distribute them among a limited assortment of records and then insert a neatly printed card bearing the slogan, "Timely Suggestions."

W. E. Moore & Co., North Cambridge, Mass., Victor dealers for the past seven years, are bringing their store to the attention of the public by means of well-written publicity in the local papers.

INDIANAPOLIS AS CABINET CENTER

Nearly 50,000 Talking Machines Cased and Assembled in That City During the Past Year, According to Figures Issued by Local Bank

INDIANAPOLIS, IND., November 4.—The Fletcher American National Bank, of this city, which has been carrying an interesting series of advertisements in the local newspapers calling attention to the many industries located in the city and the extent of their output under the general caption of "We Believe in Indianapolis," recently carried a piece of copy of particular interest to the talking machine trade setting forth the prominence of the city in the matter of talking machine cabinet manufacture. Under the caption, "Phonograph Cabinets," the advertisement read:

"Although America's phonograph industry has its center in the East, many of the machines are placed in Indianapolis-made cabinets and shipped to their final destination from this city. Last year nearly 50,000 phonographs bearing the names of the famous Eastern talking machine companies were shipped to Indianapolis to be placed in beautifully finished cabinets made in Indianapolis workshops and from here delivered to central and far Western points.

"Lumber for this purpose is shipped to Indianapolis from all the great forest regions of the United States and from many Old World ports, including the mahogany that comes from Nicaragua and darkest Africa. Here the wood is fashioned into the cabinets and given its beautiful finish by thousands of Indianapolis workmen."

CHARLES E. MOIR FEATURED

Charles E. Moir, who handles the Victor, Brunswick, Cheney, Sonora and L'Artiste products in Cambridge, Mass., was the subject of an extended write-up in the Chronicle, of that city, recently, which was accompanied by a portrait of this enterprising merchant.

GRANBY PLANT TO BE ENLARGED

Business With This Corporation Shows Steady Increase—Investigating Factory Practices

NORFOLK, VA., November 1.—Activities at the headquarters of the Granby Phonograph Corp., in this city, are numerous. Preparations are being made to enlarge the factory in Newport News. The increasing business is reported as remarkable and this will be the fourth time within two years that it has become necessary to increase facilities to take care of growing business.

Irving Beckhardt, of the credit department, and C. T. Westmoreland, factory superintendent, have been making a country-wide investigation of factory practices to procure new ideas for use in the Granby factory at Newport News. This trip covered many of the furniture factories in North Carolina, Cincinnati, Louisville and other Southern cities. Investigation will also be carried into Michigan and through New England.

F. D. W. Connelly, of the Philadelphia office, recently spent two weeks at the factory. While in Virginia he visited several of the important cities of this State in the interest of Granby.

Harry Coplan, sales manager of the corporation, has been traveling through New England, Philadelphia and New York State. He reports that business is improving materially and predicts a busy season ahead.

EIGHT VICTOR ARTISTS IN PEORIA

The Eight Famous Victor Artists attracted much attention in Peoria, Ill., recently, where they gave a concert under the auspices of the Peoria Music Co., Victor dealer in that city. Before the concert the artists visited the store of the Peoria Music Co. and held an informal reception.

"All things come to him who waits" is an old and false prophecy as many failures can testify.

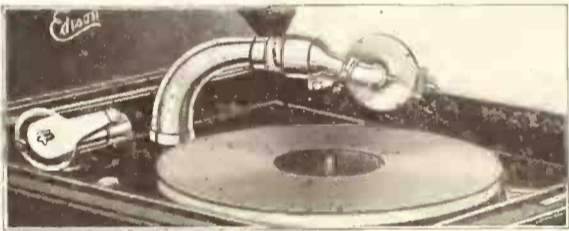

Showing Reproducer of Jewel Attachment turned up to change needle. Also position when not in use.

Plays all types of records. Operates the same as the "EDISON" with the LEVER.

No adjustments necessary when changing from lateral to vertical cut records. Stop prevents swinging to the right.

Needle scratch almost entirely removed.

Turning back of Reproducer permits of easy access to needle socket and saves records from unnecessary scratching.

Is the ONLY attachment that plays vertical cut records in the proper "EDISON" position with the Reproducer turned FACE DOWN to the record, giving it a floating action.



Showing Jewel Attachment in position for playing vertical cut records.

THE IMPROVED Jewel ATTACHMENT FOR EDISON

N O T

Just Another Attachment

B U T

a distinct improvement in Tone Reproduction as well as in Mechanical Construction and Finish.

Send for descriptive circular which contains "HINTS REGARDING THE CARE OF A PHONOGRAPH."

If your jobber does not handle, write us.

Price the same. Liberal discount to dealers.

GUARANTEED IN EVERY WAY.

MONEY BACK IF NOT SATISFIED.

We handle highest grade Jewel Point Needles.

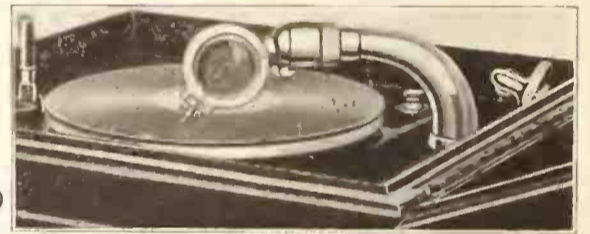

Showing face view of Jewel Attachment in position for playing lateral cut records.

Needle CENTERS on all records.

Straight air-tight construction and absence of movable joints insure perfect reproduction and great volume.

Pivoted ball-joint insures perfect reproduction and freedom of movement both vertically and horizontally.

Weight is the lightest that can produce perfect results, thus saving the record, and permitting a freedom and sweetness of tone considered impossible.

Indestructible NCM-Y-KA diaphragms do not blast, crack, split or warp, and are the greatest development in phonographic sound reproduction in years.



Showing back view of attachment in position for playing lateral cut records.

JEWEL PHONOPARTS COMPANY

154 W. Whiting St., Chicago

*Have you received
your data sheet
for listing in the*

TALKING MACHINE WORLD TRADE DIRECTORY?

*If you have not yet received
your data sheet for listing in
this Directory, please advise us
by return mail and we will send
you one immediately.*

There is no charge for directory listing. We are offering a limited amount of advertising space in this directory, and if you are interested in securing space, reservations should be made without delay.

THE TALKING MACHINE WORLD TRADE DIRECTORY will be the first accurate and complete Directory ever published in the talking machine industry. If you are a manufacturer or jobber of any product associated with the industry in any way, it will be to your distinct advantage to be listed properly.

This directory is being published in response to the demands of the trade, which have become more and more insistent during the past five years. Moreover, the publishers of "The Talking Machine World" now regard the industry as sufficiently stabilized to warrant the compilation of an accurate and reliable directory.

THE TALKING MACHINE WORLD TRADE DIRECTORY

Compiled by

373 Fourth Avenue



New York City

The immortal Toreador's Song from *Carmen* is Riccardo Stracciari's opportunity to make a masterful record in his rich, full baritone, with a male chorus supporting him. It's a masterpiece! Columbia 49968.

Columbia Graphophone Co.
NEW YORK



VICTOR ARTISTS IN INDIANAPOLIS

Octette Accorded Enthusiastic Reception on Appearance at Murat Theatre

INDIANAPOLIS, IND., November 1.—The Eight Famous Victor Artists were brought to this city recently through the efforts of several local Victor dealers, together with the Stewart Talking Machine Co., Victor wholesaler, and achieved a veritable triumph on their appearance at the Murat Theatre. Not only did the citizens of Indianapolis turn out in sufficient numbers to pack the theatre, but a number of Victor dealers outside the city took advantage of the opportunity to hear the artists.

Billy Murray acted as master of ceremonies and won many laughs with his clever introductions, as well as much applause after the singing of "Ten Little Fingers and Ten Little Toes" and the several encores that followed.

The Peerless Quartet won fresh laurels with their group singing "Linda," "I'm Missin' Mamma's Kissin'," "Somebody's Mother" and a firelight medley of old-fashioned airs sung unaccompanied. The Sterling Trio also received their share of applause.

While the greater part of the program was of the popular type of music Frank Croxton, an Indianapolis boy by birth, added a touch of operatic atmosphere by singing the well-known "Song to the Evening Star" from "Tannhauser," and the favorite classic, "Drink to Me Only With Thine Eyes," and as an extra "The Night Has a Thousand Eyes." Mr. Croxton has a deep, rich, bass voice that seemed peculiarly adapted to his style of selections.

Fred Van Eps proved to be a cyclonic performer on his banjo and won much applause by his presentation of a group of old negro favorites and variations on "Suwanee River." Frank Banta deserves much credit for his clever accompanying work.

Henry Burr gave a few semi-classics that were thoroughly appreciated, and Monroe Silver brought peals of laughter from his hearers by his Cohen stories.

TRIBUNE DESCRIBES RECORD MAKING

Article in the New York Tribune Is Indicative of Newspaper Interest in the Industry

An article appearing recently in the Sunday issue of the New York Tribune, entitled "From Squawk to Beethoven Symphony," by Lawton Mackall, describes some interesting features of record recording and relates the history of the advance in talking machine manufacture. The article, which covers a complete page, relates technical details of record making in language which the layman can easily understand. This is but another evidence of the increased interest exhibited by the newspapers and writers in the industry, which is providing some valuable free publicity.

Be sure you're right and then—soft pedal on the "I-told-you-so" stuff.

AN EFFECTIVE VOCALION WINDOW

Cincinnati Branch of Aeolian Co. Arranges a Most Effective Display

An unusually attractive display of Vocalions and Red Vocalion records was recently arranged in the branch store of the Aeolian Co. in Cincinnati, O., the entire window being given over to the exhibit. The centerpiece was a huge re-



An Artistic Window Arrangement production of a Vocalion record, while records from the current lists were suspended from the ceiling and others arranged in racks at each side of the window. Portraits of the various exclusive Vocalion artists were also featured in the display, as were also some of the more popular machines, and the whole arrangement attracted unusual interest and comment. The general effect of the window is given in the accompanying illustration, which, of course, should be seen in person to fully appreciate its merits.

APPOINTED CHENEY DISTRIBUTORS

Van Korn-Shower Co. to Wholesale That Line in State of Michigan

DETROIT, MICH., November 3.—B. K. Van Korn and C. J. Shower have been appointed distributors for the Cheney Talking Machine Co. in the State of Michigan. They style their company the Van Korn-Shower Co. and they have established offices at 205 Farwell Building, this city. They also represent the Odeon Record Co. and the New York Brush Co. in the same State.

NEW ALBUM FOR HOLIDAY TRADE

"Peerless De Luxe" Album Designed for Sale as Special Christmas Gift

The Peerless Album Co., of 638 Broadway, New York, has just announced to the trade a new record album made particularly for holiday business. It has been given the trade name of "Peerless De Luxe." The new product is the conception of Phil Ravis, president of the company, who has long felt that there was need for an album which would be an appropriate Christmas gift. The "Peerless De Luxe" is bound in two-tone Spanish mission, the inside covers of which are lined with genuine moire silk, the metal bindings being gold-plated. The covers are also gold-finished and bevel-edged. The new album is of the highest quality and should meet with popular approval.



HENRY BURR



ALBERT CAMPBELL



JOHN MEYERS

EIGHT FAMOUS VICTOR ARTISTS

In Concert and Entertainment
Personal Appearance of
Eight Popular Victor
Favorites on One Program

A live attraction for live dealers and jobbers

Bookings now for season 1921-1922
Sample program and particulars upon request

P. W. SIMON, Manager
1658 Broadway New York City



FRANK CROXTON



MONROE SILVER

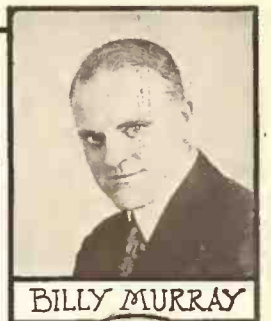

BILLY MURRAY



FRED VAN EPS



FRANK BANTA

Famous Ensembles including
Campbell & Burr - Sterling Trio - Peerless Quartet

Emerson Records

For Christmas

Each record on the Emerson list for December is a holiday-spirit contribution in itself.

Christmas hymns and standard Yuletide selections.

Santa Claus records for "Kiddies."

The latest of the late mid-winter song hits, and

Dance inspiration in five records of genuine syncopated harmony.

SPECIALS FOR CHRISTMAS

- 10459 { KIDDIES' PATROL (Christmas Eve) (Walter Rogers). Descriptive } Emerson Concert Band
- 10459 { KIDDIES' DANCE (Christmas Morning) (Walter Rogers). Descriptive }
- 10270 { HARK! THE HERALD ANGELS SING (Mendelssohn). Male Quartet..... } Stella Quartet
- 10270 { JOY TO THE WORLD (Handel). Male Quartet..... }
- 1087 { HOLY NIGHT, PEACEFUL NIGHT (Mohr-Gruber). Male Quartet..... } Shannon Four
- 1087 { ADESTE FIDELES (Come All Ye Faithful) (J. Reading). Male Quartet..... }

THE EXCLUSIVELY EMERSON PICTURE RECORDS

By Emerson Entertainers

- A100 { LITTLE RED RIDING HOOD. Story with Animal Imitations. }
- A100 { THE THREE BEARS. Story with Animal Imitations. }
- A101 { MOTHER GOOSE RHYMES. With Song Accompaniments. }
- A102 { MOTHER GOOSE RHYMES (Second Series). With Song Accompaniments. }

STANDARD NUMBERS

- 10460 { LEAD, KINDLY LIGHT (Newman-Dykes). Male Quartet } Trinity Quartet
- 10460 { ALMOST PERSUADED (P. P. Bliss). Male Quartet..... }
- 10461 { MY FAITH LOOKS UP TO THEE (Palmer-Mason). Tenor and Contralto Duet, Orch. Accomp..... } Reed Miller and Nevada Van der Veer
- 10461 { THE LORD IS MY SHEPHERD (Smart-Passmore). Tenor and Contralto Duet, Orch. Accomp..... }
- 10462 { RUSTLE OF SPRING (Sinding). Piano Solo..... } Mana Zucca
- 10462 { VALSE BRILLANTE (Mana Zucca). Piano Solo..... }
- 10463 { BARCAROLLE, from "Tales of Hoffmann" (Offenbach). Instrumental Trio..... } Longo Trio
- 10463 { WERE MY SONG WITH WINGS PROVIDED (Reynaldo Hahn). Instrumental Trio.. }
- 10464 { THE LAST ROSE OF SUMMER (Moore). Soprano Solo, Orch. Accomp..... Vivian Holt
- 10464 { JUST A-WEARYIN' FOR YOU (Stanton-Jacobs-Bond). Contralto Solo, Accomp by Piano, Violin and 'Cello Corinne Morgan Welsh

DANCES

- 10450 { SWEET LADY, Medley. From Musical Production "Tangerine" (Johnson-Crumit-Zoob). Fox-trot, Piano Solo with Vocal Chorus by Irving Kaufman..... } Eubie Blake
- 10450 { MA (Con Conrad). Fox-trot, Piano Solo..... }
- 10452 { TUCK ME TO SLEEP (In My Old 'Tucky Home) (George W. Meyer). Fox-trot. } Bennie
- 10452 { (Glow, Little) LANTERN OF LOVE (Fred Fisher). Fox-trot..... } Krueger's Orchestra
- 10453 { WHEN THE HONEYMOON WAS OVER (Fred Fisher). Fox-trot.. } Joseph Samuels' Music Masters
- 10453 { TENDERLY (Little-Stanley-Dellon). Fox-trot..... }
- 10454 { BABY FACE (Benson-Howard). Fox-trot..... } Van Eps Specialty Four
- 10454 { HOW MANY TIMES? (Robinson-Turk). Intro.: "Mama Whip, Mama Spank." Medley Fox-trot..... }
- 10455 { ROSY CHEEKS (Young-Parish-Squires). Fox-trot..... } Joseph Knecht's Waldorf-Astoria Orchestra
- 10455 { LOVE ME (All of the Time) (A. MacIntosh). Fox-trot }

SONG HITS

- 10451 { BIMINI BAY (Whiting-Kahn-Egan). Novelty Song, Orch. Accomp..... Arthur Fields
- 10451 { MANDY 'N' ME (Kalmar-Conrad-Motzan). Tenor Solo, Orch. Accomp..... Irving Kaufman
- 10456 { CRY-BABY BLUES (Young-Lewis-Meyer). Character Song, Orch. Accomp..... Eddie Nelson
- 10456 { WHAT I WANT TO DOODLE DO FOR YOU?(Von Tilzer-Brown). Comedy Song, Orch. Accomp. Fred Hillebrand
- 10457 { I WONDER IF YOU STILL CARE FOR ME (Smith-Snyder). Tenor Solo, Orch. Accomp.. Sam Ash
- 10457 { TEN LITTLE FINGERS AND TEN LITTLE TOES (Down in Tennessee) (Pease-White-Schuster-Nelson). Novelty Song, Orch. Accomp..... Ernest Hare and Billy Jones
- 10458 { PLANTATION LULLABY (Stevens-Gillette-Holmer). Tenor Solo, Orch. Accomp..... Vernon Dalhart
- 10458 { A LITTLE SIDE STREET (Harris-Howard). Tenor Solo, Orch. Accomp..... Charles Harrison

Emerson Records in Italian, Hebrew-Jewish, German and Polish are leaders in their respective languages.



The Emerson Phonograph Co.

317 So. Wabash Avenue
Chicago

206 Fifth Avenue
New York City

FOUR CELEBRATED ARTISTS TO RECORD FOR BRUNSWICK

Claire Dux, Soprano; Tino Pattiera, Tenor; Elly Ney, Pianiste, and Bronislaw Huberman, Violinist, Appearing in Operatic and Concert Fields, Now Recording Exclusively for Brunswick

Brunswick dealers and Brunswick record enthusiasts are awaiting with interest the first recordings of four widely known European operatic and concert artists who are now in this country for the first time and are being announced to the trade by the phonograph division of the Brunswick-Balke-Collender Co. as exclusive Brunswick artists. All of these artists have appeared before European audiences for several years past, where their brilliant performances won the praises of critics in the leading musical centers.

Two of these artists are singers of note, Claire Dux, soprano, and Tino Pattiera, tenor, who are to make their American debut this coming season with the Chicago Opera Company and will be heard in New York when that organization comes here for its annual visit. Pattiera is a native of Dalmatia and made his greatest success in tenor roles of the Puccini and Verdi operas. Claire Dux has been known as one of the leading mezzo-sopranos appearing in the opera houses of Europe and Mary Garden, hearing that there was a possibility of Mme. Dux making an American tour, immediately offered her a contract to sing for the Chicago Opera Company. Mme. Dux has appeared in Covent Garden, London; the Royal Opera of Berlin, La Scala, Milan; Royal Opera, Stockholm; Royal Opera, Petrograd.

Elly Ney, who has just made her American debut in New York, is an accomplished pianiste, who has delighted European audiences with her work. Local musical critics stamp her as an artist of unquestioned ability. Bronislaw Huberman, violinist, came to this country as a child prodigy when only fourteen and his playing in New York last month, after an absence of twenty-four years, confirmed the good opinion held of his talents abroad.

The officials of the Brunswick Co. have been

negotiating for the engagement of these European artists for some time past and were largely instrumental in bringing them to this country. When arrangements for their appearance here were finally consummated the Brunswick Co. immediately took steps to secure the rights to make recordings of these artists on Brunswick records exclusively. William A. Brophy, head



1.—Elly Ney, Pianiste; 2.—Claire Dux, Soprano; 3.—Bronislaw Huberman, Violinist; 4.—Tino Pattiera, Tenor.

of the recording laboratories in New York, has already made several tests of them and he states that records by these artists will be ready for distribution to the trade about December 1. Their release, then, is most timely, as all these artists are now appearing before American audiences.

Claire Dux opened November 14 as Mimi in "La Boheme," with the Chicago Opera Company. Then she appears in Kansas City November 23; Detroit, December 6; New York City, November 29, January 22; Lynchburg, Va., February 6; Concord, N. H., February 23; Detroit, March 9; Montgomery, Ala., March 30, and several other cities which will be announced later.

Tino Pattiera will make his first American ap-

pearance as Canio in "Pagliacci" the second week of November with the Chicago Opera Company. He will next appear at Lynchburg, Va., December 6, and will give several concerts in addition to being heard with the Chicago Opera Company in New York City during the month of January.

Elly Ney is booked to appear in most every large city in this country, following her debut in New York City on October 18, where she was received most enthusiastically. She appeared in Detroit November 3 and 4; New York City, November 8; Oswego, N. Y., November 11; Richmond, Va., November 15, and will appear in Athens, Ga., November 17; Atlanta, Ga., November 19; New York City, November 26; Boston, Mass., November 27; Evanston, Ill., December 1; Quebec, Can., January 9; Three Rivers, Quebec, January 11; Montreal, January 13; New York City, January 22 and February 5; Chattanooga, Tenn., March 7.

Bronislaw Huberman, after making his first American appearance in New York in October, is scheduled to be heard in the following cities: St. Paul, Minn., October 27; Minneapolis, Minn., November 28; Philadelphia, Pa., November 1; New York City, November 8, 12 and 18; Lynchburg, Va., November 21; Baltimore, Md., November 25; New York City, November 29; Washington, D. C., December 1; Brooklyn, N. Y., December 4; New York City, December 11; Columbia, Mo., December 14; St. Louis, Mo., December 16 and 17; Omaha, Neb., December 18; New York City, January 1; Chicago, Ill., January 10; Providence, R. I., January 24; Rochester, N. Y., February 1.

Mr. Brophy states that Brunswick dealers are being supplied with attractive advertising material, so that they can capitalize on the visits of these artists in their cities. Also the Brunswick Co. is to announce these exclusive Brunswick artists in a nation-wide campaign of advertising in the leading newspapers and magazines in the country.

The engagement of these artists, Brunswick officials state, is the forerunner of several more to be announced this Winter, as it is the purpose and aim of this company to have in its record catalog a complete series of operatic and classic music, rendered by the best artists obtainable. Already records have been issued by the Brunswick Co. of several widely known artists who are exclusively Brunswick, among whom are Mario Chamlee, tenor; Giuseppe Danise, baritone; Florence Easton, soprano, who are appearing in leading roles with the Metropolitan Opera Company, this city. Also records of Irene Pavolska and Marie Tiffany, who are members of the Chicago Opera Company, have been released to the trade and have met with considerable favor.

Nothing is more important to the dealer than to see that his sales force keep the record stock in good condition. Having the needed records and being able to supply customers without delay is a valuable asset.

Quality

Distinction

The "VICSONIA" Reproducer

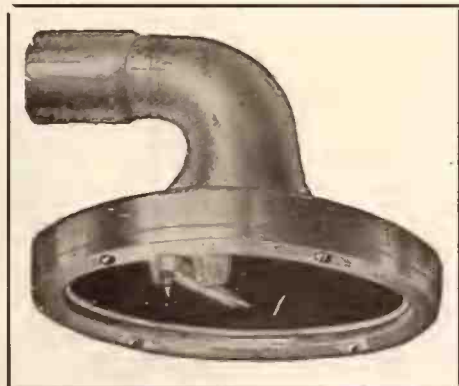

Recognized for its Perfect interpretation of Edison Disc Records on Victrolas and Grafonolas.

Fitted with permanent jewel point. No loose parts.

Note: The Vicsonia is made of Bronze, sand casted and machined to measurement. Finished in heavy Nickel or Gold plate. Flexible stylus.

Meet the demand—Serve your customers

Sample Model "A" or "B" Vicsonia will be sent on receipt of \$4.50. Retail price \$7.50.

Note: Model "B" Vicsonia plays both Edison and Pathé records.

VICSONIA MFG. CO., Inc.

313 E. 134th STREET

NEW YORK, N. Y.



Selling a Profitable Line

Sales are necessary to business.

But sales, no matter how large, without a satisfactory net profit, mean disaster. It is better to show big profits on a small investment than small profits on a big investment.

An extra large discount does not mean large profits if there is no demand for the goods purchased. The difference between an extra large and a normal discount is a great deal less than the extra expense required to sell such goods.

Sell a phonograph that means the most to you in the long run—one that bears a favorable reputation—one that will compare favorably in any side-by-side test with other phonographs—a quick turnover phonograph. Such is

The Highest Class Talking Machine in the World

THE INSTRUMENT OF QUALITY
Sonora
CLEAR AS A BELL 

Sonoras are now selling at revised prices based on present costs

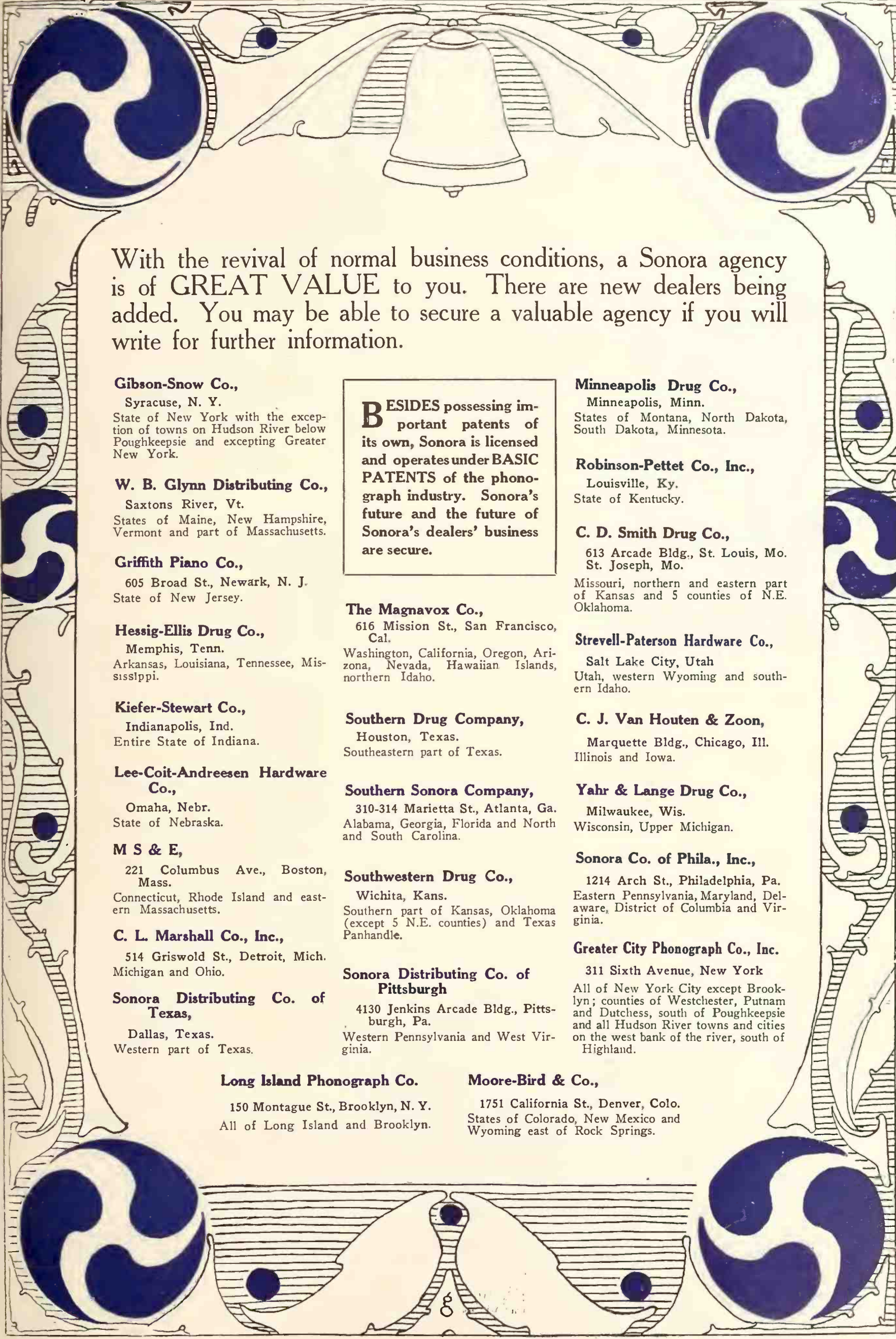

With the revival of normal business conditions, a Sonora agency is of **GREAT VALUE** to you. There are new dealers being added. You may be able to secure a valuable agency if you will write for further information.

Gibson-Snow Co.,

Syracuse, N. Y.
State of New York with the exception of towns on Hudson River below Poughkeepsie and excepting Greater New York.

W. B. Glynn Distributing Co.,

Saxtons River, Vt.
States of Maine, New Hampshire, Vermont and part of Massachusetts.

Griffith Piano Co.,

605 Broad St., Newark, N. J.
State of New Jersey.

Hessig-Ellis Drug Co.,

Memphis, Tenn.
Arkansas, Louisiana, Tennessee, Mississippi.

Kiefer-Stewart Co.,

Indianapolis, Ind.
Entire State of Indiana.

Lee-Coit-Andreesen Hardware Co.,

Omaha, Nebr.
State of Nebraska.

M S & E,

221 Columbus Ave., Boston, Mass.
Connecticut, Rhode Island and eastern Massachusetts.

C. L. Marshall Co., Inc.,

514 Griswold St., Detroit, Mich.
Michigan and Ohio.

Sonora Distributing Co. of Texas,

Dallas, Texas.
Western part of Texas.

BESIDES possessing important patents of its own, Sonora is licensed and operates under **BASIC PATENTS** of the phonograph industry. Sonora's future and the future of Sonora's dealers' business are secure.

The Magnavox Co.,

616 Mission St., San Francisco, Cal.
Washington, California, Oregon, Arizona, Nevada, Hawaiian Islands, northern Idaho.

Southern Drug Company,

Houston, Texas.
Southeastern part of Texas.

Southern Sonora Company,

310-314 Marietta St., Atlanta, Ga.
Alabama, Georgia, Florida and North and South Carolina.

Southwestern Drug Co.,

Wichita, Kans.
Southern part of Kansas, Oklahoma (except 5 N.E. counties) and Texas Panhandle.

Sonora Distributing Co. of Pittsburgh

4130 Jenkins Arcade Bldg., Pittsburgh, Pa.
Western Pennsylvania and West Virginia.

Long Island Phonograph Co.

150 Montague St., Brooklyn, N. Y.
All of Long Island and Brooklyn.

Moore-Bird & Co.,

1751 California St., Denver, Colo.
States of Colorado, New Mexico and Wyoming east of Rock Springs.

Minneapolis Drug Co.,

Minneapolis, Minn.
States of Montana, North Dakota, South Dakota, Minnesota.

Robinson-Pettet Co., Inc.,

Louisville, Ky.
State of Kentucky.

C. D. Smith Drug Co.,

613 Arcade Bldg., St. Louis, Mo.
St. Joseph, Mo.
Missouri, northern and eastern part of Kansas and 5 counties of N.E. Oklahoma.

Strevell-Paterson Hardware Co.,

Salt Lake City, Utah
Utah, western Wyoming and southern Idaho.

C. J. Van Houten & Zoon,

Marquette Bldg., Chicago, Ill.
Illinois and Iowa.

Yahr & Lange Drug Co.,

Milwaukee, Wis.
Wisconsin, Upper Michigan.

Sonora Co. of Phila., Inc.,

1214 Arch St., Philadelphia, Pa.
Eastern Pennsylvania, Maryland, Delaware, District of Columbia and Virginia.

Greater City Phonograph Co., Inc.

311 Sixth Avenue, New York
All of New York City except Brooklyn; counties of Westchester, Putnam and Dutchess, south of Poughkeepsie and all Hudson River towns and cities on the west bank of the river, south of Highland.

CENTRAL OHIO DEALERS ORGANIZE

Victor Retailers in That Section Meet in Columbus and Form New Association, With Leslie I. King, of Columbus, President

COLUMBUS, O., November 4.—Ninety retail dealers in Victor talking machines and records came from a number of towns that are within a seventy-five-mile radius of this city last month and formed the Central Ohio Victor Talking Machine Retail Dealers' Association.

Leslie I. King, manager of the Victrola department of the Morehouse-Martens Co., Columbus, was elected president of this organization. In Mr. King's initial speech to members of this Association he said: "Because all the Victor dealers are anxious to maintain the highest



Leslie I. King

standard of excellence in their service to the public and in order that business methods might be employed whereby customers would have their requirements filled along musical lines in a way that would give the dealers their confidence we have decided to form this organization."

Mr. King further stated that conventions will be held annually and that at these conventions the members will "talk shop" and not have the meetings serve as social gatherings. "We will from time to time send out bulletins that will give the best methods in salesmanship." The work of issuing bulletins has been delegated to an executive committee whose duty it is to observe all the things that go to sell Victrolas and records and then to incorporate their observations on this subject in the bulletin. "By doing this," Mr. King stated, "not only will the dealers stimulate their trade, but the public will be greatly benefited. They will get something even better than what they want in the musical field.

And to serve the public in the best possible way, that is the aim of this organization."

Some time during the month of November a meeting of this organization will be held in Columbus, when the time and place for the 1922 convention will be definitely decided.

Other officers elected are: E. O. Collender, Zanesville, vice-president; Frank Sells, Delaware, secretary, and M. L. Phillips, Mt. Gilead, treasurer.

GOOD REASONS FOR OPTIMISM

R. C. Clark, of Granby Road Forces, Tells of Better Conditions—Expects Big Holiday Trade

COLUMBUS, O., November 4.—Robert C. Clark, who covers southern Ohio and eastern Kentucky for the Granby Phonograph Corp., of Norfolk, Va., reports that business in his territory is showing a decided increase. Everything points to a healthy holiday business. Not only is business good in the talking machine field, but among many of the large industries in that locality which favorably affect the buying power of the public.

Among the large industries which are speeding up production is the National Cash Register Co., of Dayton, O., which employs several thousand people. The increased activities of this plant alone have caused a spread of optimism among the dealers in that section of the State. The dealers in this city also are very optimistic and are making great preparation for the holiday business.

FILES SCHEDULES OF CREMONA CO.

Liabilities of Cremona Phonograph Co., Portland, Ore., Given by Secretary as \$107,782, With Assets of Only \$31,666

PORTLAND, ORE., November 2.—According to a report filed in the Federal court last week by H. E. Witham, secretary of the Cremona Phonograph Co., which recently filed in bankruptcy, the total liabilities of the company are \$107,782.01, with assets of \$31,666.39. Of the liabilities the secured claims amount to \$62,075.37, while the unsecured claims are \$40,640.25. The assets consist of real estate to the value of \$6,050 and the balance, \$23,845.08, are notes, bills, etc. The principal creditors are: A. B. Cutler, who holds certificates amounting to \$10,262; Mary L. Eaton, \$11,114.25; F. W. Cutler, \$18,611.45; Coast Bond & Finance Co., \$15,155.57, and the Northwest Finance Corp., \$5,678.30.

A. J. Johnson, Victor dealer in Fall City, Neb., makes it a point to publish the full Victor list of records in his advertisement in the local papers, which has proven quite a factor in bringing business to his store.

Special advertising and sales campaigns are in order to make the holiday season pay adequate dividends.

NYOIL
FOR YOUR PHONOGRAPH

IN THE
HANDY
CAN



**Made in Our
Watch Oil
DEPARTMENT**

which for half a century
has made 80% of all the
watch, clock and chronom-
eter oil used in America.

The Best Oil For Any Talking Machine

In refining, Nyoil is given the same care as our famous watch oil receives. All gums and impurities are removed, leaving it

Colorless, Odorless and Stainless.

Housekeepers say they would not be without Nyoil because it is best for phonographs and sewing machines—for polishing furniture and woodwork and is odorless and will not stain. It is free from acid and will not gum, or become rancid. Sportsmen find it best for guns because it prevents rust.

NYOIL is put up in 1-oz., 3-oz. and 8-oz. Bottles
and in Quart and Gallon Cans.
For Sale by all Talking Machine Supplies Dealers
WILLIAM F. NYE, New Bedford, Mass., U.S.A.

CO-OPERATION NEEDED TO SUCCEED

Employer Who Assumes an Attitude of Superiority Curtails Enthusiasm of Men—Sales Drop and Disorganization Often Results

In many business houses there is a lack of co-ordination between employes and employer which cannot help but be detrimental to the best interests of the business. Employers sometimes become so imbued with their own importance that they assume an attitude of autocratic superiority which arouses the antagonism of employes. The result is grumbling, discontent and a consequent falling off of enthusiasm which naturally results in a decline in sales. If such a condition exists the employer has no one to blame but himself, and instead of seeking to replace his old and tried salesmen and employes with others he should remedy his own attitude in order to keep the morale of his staff as high as possible. Many a manager and business man has failed because he lacked those qualities of humaneness which mark the true executive and which are absolutely essential if the best efforts of the salesmen are to be brought out for the benefit of the firm.

"THE BATTLE OF ALLIANCE"

CLEVELAND, O., November 8.—H. C. Schultz, of the Kennedy-Schultz Co., representative of the Granby Phonograph Corp., of Norfolk, Va., in this city, is the author of an interesting volume, entitled "The Battle of Alliance." The book has been prepared for private distribution and those who have read it say it proves the author has no little ability as a fiction writer.

The Record That Wins by Comparison

Okeh Records



The Service That Suits ALL DEALERS' NEEDS

Independent Jobbing Company

Okeh Record Distributors

Goldsboro, North Carolina

Victrolas

From \$25. to \$1500.



Look under the lid
Look on the label



OUR NAME

Successful people are always on the "go." Too speedy oftentimes, Mr. Victor Dealer, to learn where you are located. Billboards! Billboards! so that "he who runs may read - and tumble"

C. BRUNO & SON, Inc.
351-353 Fourth Ave. - New York
VICTOR WHOLESALER
TO THE DEALER ONLY



T.M.W.

CABLE ADDRESS REG'D
"FILASSE—PHILA."

EXTRA! Mr. Phonograph Industry **EXTRA!**

LONG DISTANCE 'PHONE
BARING 535

IMICO SHAFT No. 4 "COMES IN" WITH BIG PRODUCTION

Collect Your Dividends Now by Obtaining Lower Quotations

Send for Samples and Special Quotations Effective November 15th.

**IMICO INDIA RUBY
MICA DIAPHRAGMS**

INTERNATIONAL MICA COMPANY PHILADELPHIA, PA., U.S.A.
YOKOHAMA, JAPAN

Still the Standard
There's a Reason



and Will Remain
Why NOT IMICO

FACTORY AND SALES DEPT.,
37TH AND BRANDYWINE STS.,
WEST PHILA., PA.
V. T. SCHULTZ
CLEVELAND, OHIO
RAYSOLO SALES CO.
LANCASTER, PA.

ARTHUR BRAND & COMPANY
CINCINNATI, OHIO
WALTER S. GRAY
SAN FRANCISCO, CAL.
DAVENPORT PHONOGRAPH &
ACCESSORY CO.
DAVENPORT, IOWA

ARTOPHONE COMPANY
ST. LOUIS, MO.
STEINOLA COMPANY
KANSAS CITY, MO.
PROVIDENCE PHONOGRAPH
SUPPLY CO.
PROVIDENCE, R. I.

HE KNOWS HIS BUSINESS COSTS

The Business Man, Whether Running a Small Store or Large Manufacturing Plant, Should Know Exactly the Cost of Operation

The efficient head of to-day's business doesn't guess—he knows. He knows his exact cost of doing business. He has at his fingers' tips the entire cost of every article in his store, and the cost of every operation, handling, selling and delivery. He knows, at any moment, whether he is making or losing money.

Now, these cost records are not kept because the business is big; but rather the business is big because the costs are known.

You are traveling on guesswork, and are running the risk of failure

—unless you know how much it costs you to sell your goods;

—unless you know how much your delivery costs amount to;

—unless you are carrying a depreciation account on your books, and are charging depreciation of your equipment as part of business cost;

—unless you know exactly what each and every item of expense amounts to and figure it against the running of your business.

The majority of mercantile failures can be charged up to ignorance on the part of the merchant of his own business.

A simple set of accounts, intelligently kept, will guard you from this. Don't try to "keep your business in your hat." If you do, you'll soon find that you will either have to take it out or get out yourself.

NIGHT FORCE ON RECORD OUTPUT

Bridgeport Die & Casting Co. Busy From 7 A. M. to 10 o'Clock at Night

BRIDGEPORT, CONN., November 3.—The Bridgeport Die & Machine Co. has already inaugurated night work in its plant in this city, thus continuously pressing records from 7 o'clock in the morning until 10 o'clock at night. The various records pressed by this company are proving very popular and the demand is steadily increasing.

THE STORE WAS REALLY CROWDED

St. Louisans Turn Out in Great Numbers to Help Kirkland Piano Co. Celebrate

St. Louis, Mo., November 4.—When Jonas H. Kirkland, who does business as the Kirkland Piano Co., at 204 North Twelfth street and 2024 East Grand avenue, this city, gave an anniversary party at his East Grand avenue store he was swamped with guests. In the year that he had operated the branch store he had remodeled



Crowd at the Kirkland Anniversary
it, and on the first anniversary he sent 2,200 postal announcements to customers on his mailing list and scattered 10,000 handbills around the neighborhood.

The doors were opened at 7.30 p. m. and until 10.30 the store was filled and there were so many people on the sidewalk and in the street that policemen were needed to handle the traffic. The crowd coming in at the front door was so great that people in the store could not get out that way and it was necessary to open the back doors to let them out.

Mr. Kirkland has only been in the piano and talking machine business a short time and his energy and enterprise have caused older music merchants to take notice. He is only twenty-six years old. His sales organization consists of Messrs. H. Semple and C. Edelmann and Misses E. Repple and M. Koetting. He handles the Brunswick phonograph and Cable pianos.

The M. J. Keenan Music Store, at 125 North Main street, Austin, Minn., is bringing his talking machine, piano and other lines of musical instruments to the attention of the public through local publicity.

A product is only well sold when it stays sold. In other words, when it gives continued satisfaction and makes friends for the house.

KEY HALL
VICTOR MOBILE DISTRIBUTOR
ALABAMA

Serving
Victor Dealers
in
Mississippi
Alabama
Florida

VICTOR VICTROLAS
VICTOR RECORDS

THE PASSING OF I. DAVEGA

Had Been Identified With Talking Machine Industry for a Long Period of Years—Business Now in Charge of Abram Davega

In the passing of I. Davega, president of the Knickerbocker Talking Machine Co., New York City, which was announced in last month's issue of *The World*, the industry has lost a member who was identified with it in a prominent way. For a number of years president of I. Davega, Jr., Inc., which later became the Knickerbocker Talking Machine Co., Mr. Davega centered his activities on the wholesaling of Victor merchandise. In his long connection with the trade Mr. Davega formed many lasting friendships and the news of his death caused great sorrow. The active management of the Knickerbocker Talking Machine Co. has passed on to Abram Davega, the only son, and who for the past few years has been practically in full charge of the business during the illness of his father. I. Davega is survived by a widow, his son, Abram Davega, and a daughter, who is Mrs. Byron R. Forster, wife of the well-known president of the Brilliantone Steel Needle Co.



I. Davega

HALLOWE'EN IN WASHINGTON

Talking Machine Houses Arrange Elaborate Window Displays for the Occasion

WASHINGTON, D. C., November 4.—The leading music stores of the Capital City during the past week led all other establishments in point of attractiveness of display. All decorated their windows to some extent, featuring All Hallowe'en, while several of the retailers went to considerable expense and effort.

One of the most attractive of these displays was that of E. F. Droop & Sons Co., Victor wholesalers. On the G street side of the store the window featured pianos. The flooring of the window was covered with straw and in the center was a huge pile surmounted by a Victor dog, while another smaller one was seen pushing his way through the straw at the bottom. Shiny records were made into skeleton heads by the use of white paint, and these with cut-outs and jack-o'-lanterns in pumpkin shape added to the attractiveness of the display.

The Thirteenth street window was given over

to Victrolas. Here there are numerous baskets of large yellow chrysanthemums, draped with yellow and with orange crepe paper, were filled with oak leaves. The window had a large border of laurel.

Diagonally across the street was another elaborate display in the window of the Jordan Piano Co. One of the first things viewed was a sign which deposed "You need music for your Hallowe'en party. The Victrola will give you the best." Another sign advised, "Select Your Hallowe'en Records." In the center was a Victrola and directly back of that was a painting of a wood scene forming a part of the background, the rest of the space being covered by cornstalks. To the right, in a stack of the stalks, there was a witch with illuminated face, while her counterpart held forth on the left.

INSTALLS THREE NEW BOOTHS

The Barber Music House, Great Falls, Mont., of which R. J. Barber is proprietor, has recently installed three new sound-proof booths to take care of the growing Columbia trade.

\$61,000 IN JUDGMENTS AWARDED

Decree of Foreclosure Also Entered Against the Cathedral Phonograph Co.

MARION, O., November 1.—Judgments amounting to \$61,604.79 against the Cathedral Phonograph Co. and Axel Akers, as trustee for the estate of the Cathedral Phonograph Co., a bankrupt, were awarded the cross petitioners in the common pleas court here last week in a suit of Axel Akers, as trustee for the estate of the Cathedral Phonograph Co., and others. Decree of foreclosure also was entered and the property of the bankrupt company ordered appraised and sold for cash by the sheriff on November 9.

A small advertisement which hits the nail on the head is worth more than a double-page display of generalities.

Do you believe in luck?—or rather, do you believe you are so lucky that the results of luck will be lucky for you?

In other words, can you afford to go into the phonograph business without investigating every machine that can possibly have merit?

To decide WHICH MACHINE without getting all the evidence is foolish and can only result in your making less out of your phonograph department than you might make.

Harponolas are built in every desirable cabinet style, and every

cabinet is a maximum value at its price—a model of good taste and fine craftsmanship.

Harponola tone is unusually sweet and faithful to all the fine tones in the record.

Harponolas, mechanically, are as service-proof as may be built.

And the Harponola proposition to the dealer is substantial, fair and exceptionally profitable.

You owe it to yourself to write for the Harponola proposition. Give us a chance to prove that you couldn't select a better machine from a sound merchandising standpoint.

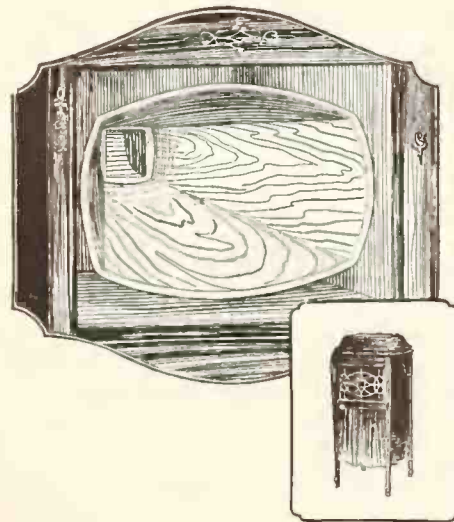

What More Can You Ask

All the features that go to make a talking machine Profitably Salable you will find as regular equipment of Magnola: "Built by Tone Specialists."



Watching the Music Come Out

Complete description of all these features is to be found in our handsome illustrated catalog, which we should like to send you. May we? Ask us to tell you our plans for your benefit!

MAGNOLA TALKING MACHINE COMPANY
 OTTO SCHULZ, President
 General Offices 711 MILWAUKEE AVENUE CHICAGO
 Southern Wholesale Branch 1530 CANDLER BLDG. ATLANTA, GA.

THE HARPONOLA COMPANY
 101 MERCELINA PARK
 Edmund Brandts, President
 CELINA, OHIO

Harponola Cabinets are built by the Mereman Brandts Brothers in a separate up-to-date factory.

The Phonograph with the "Golden Voice"
HARPONOLA



STEGER

*the finest reproducing
Phonograph in the World*



Model
506
\$295.00



Model
502
\$145.00



Model
503
\$165.00



Model
509
\$235.00

THE highest tribute a critic can pay to a phonograph is that it reproduces with absolute fidelity every beauty of tone of voice or instrument.

The artistic Steger creates the illusion of reality to perfection, so that a listener may readily imagine that he is in the presence of the living artist. It brings to the home all of the world's best music—vocal and instrumental—and plays it with a sparkling vivacity that no other phonograph can surpass.

Because the Steger tone-arm is adjustable to meet the requirements of the individual record, the Steger Phonograph plays all disc records correctly. This exclusive, patented tone-arm is only one reason why the beautiful Steger is universally known as "the finest reproducing phonograph in the world."

There is a big field for the Steger. Its popularity makes each sale easier. There is a great national advertising campaign back of the Steger that makes Steger representation a valuable asset for the progressive dealer. Hear and play the Steger yourself. Inspect the wonderful Steger tone-arm, the scientifically constructed sound-reproducer and the marvelous tone-chamber of even-grained spruce.

Desirable Territory Open

Write for the Steger proposition and Steger Phonograph Style Brochure today, if you want satisfied customers and substantial profits.

Phonograph Division

STEGER & SONS

Piano Manufacturing Company

Steger Building, . . . CHICAGO, ILL.

Factories: Steger, Illinois, where the "Lincoln" and "Dixie" Highways meet.

"If it's a Steger—it's the most valuable Piano in the world."



Model
505
\$220.00



Model
504
\$200.00



Model
501
\$115.00



Model
510
\$290.00



Model
500
\$80.00

FINANCING PLAN FOR DEALERS

Columbia Representatives to Be Given Advantage of Very Liberal Financing

Geo. W. Hopkins, vice-president and general sales manager of the Columbia Graphophone Co., New York, advised the Columbia wholesale branches recently that plans had been completed whereby Columbia dealers could be offered a very liberal financing plan.

Columbia branch managers throughout the country are ready to give Columbia dealers complete information regarding this new finance plan, which is offered to the dealers at a time that is most opportune.

HAND TO MANAGE SCRANTON STORE

SCRANTON, PA., November 1.—Plans are under way by the United Phonograph Stores, Inc., for the opening of a branch store in this city in the near future, according to an announcement made by H. W. Yeager, president of the company.

LONG CABINETS AT LOCAL SHOW

Geo. A. Long Cabinet Co. Has Attractive Display at Furniture Show—New Price List Announced on November 1—Many Orders Booked

The George A. Long Cabinet Co., Hanover, Pa., was represented at the recent New York Furniture Show by a very attractive exhibit. The popular Long console cabinets were displayed to advantage and good-sized orders were received from buyers in all parts of the country who attended the show.

H. C. Naill, who was in charge of the exhibit, assisted by his son, stated in a chat with The World that the Long factory was working to capacity in order to fill the orders for Long console cabinets and, in fact, for all of the record cabinets in the Long line.

JOINS SONORA JOBBERS' STAFF

J. J. Schratweiser, formerly a member of the sales staff of the local jobbing division of the Sonora Phonograph Co., has joined the sales force of the Long Island Phonograph Co., Sonora jobber, in Brooklyn and Long Island territory.

The Bluff City Mfg. Co., of Poplar Bluff, Mo., has opened salesrooms for its Southland phonograph, which is manufactured here, in the Ducker Hotel Building, Little Rock, Ark.

ATLANTIC CITY PUBLICITY

Sonora Is Displayed on Large Electric Sign on Atlantic City Boardwalk—Has Many Distinctive Features Which Win Attention

The Sonora Phonograph Co. has a sign on the Atlantic City boardwalk which is well known to the many thousands of pleasure-seekers who visit this famous resort.



The Great Sonora Sign

prominent cities it is, nevertheless, of unusual construction and equally as effective in the daytime as in the night. It is placed in a strategic position, as it is directly at the entrance of the Traymore Hotel, one of the world's largest and most famous hostleries, and cannot be missed by anyone walking east on the boardwalk.

The sign is unique in that the word Sonora is not painted on the board, but consists of metal letters extending out and wired from the board about twelve inches. The letters are hollow, open in the rear end near the board and each contains several powerful incandescent lamps, reflecting light on the white background.



No. 558



No. 566



No. 551

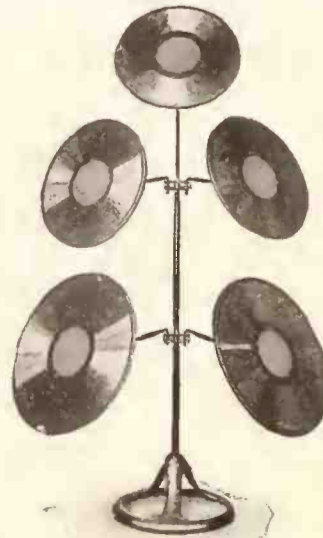

No. 501

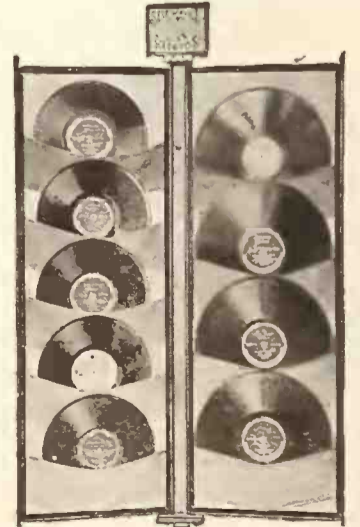

No. 550

Universal Self-Service Displayors Are Necessary in the Busy

Holiday Season, if you want to take full advantage of your record sales possibilities. The SELF-SERVICE features of the DISPLAYORS enable your regular customers to practically wait on themselves, enabling you to take good care of your trade with fewer salesmen and less expense.

Neat — Inexpensive — Attractive — They Earn Many Times Their Cost in Increased Sales

Ask Your Jobber—or Write Direct to

UNIVERSAL FIXTURE CORPORATION 133 WEST 23rd STREET NEW YORK

The NEW Scotford Tonearm and Superior Reproducer



A new external shape of grace and beauty—without changing the internal design:



The OLD

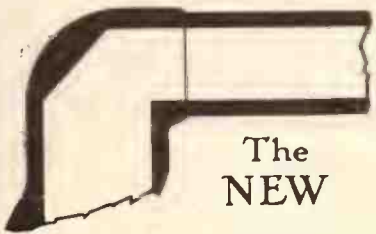

The NEW

That same angle turn with the solid inclined plane deflecting the sound waves straight downward into amplifying chamber. That same famous Scotford tone—the tone of refinement—genuinely musical. Now in a tonearm of accepted, conventional, popular design. WRITE FOR SAMPLES.

NEW CONSTRUCTION



The long straight tube is of drawn Yellow Brass. Tonearm Base, Main Elbow and Connection Elbow and the Reproducer Frame, Face Ring and Back Plate are cast of TENSO White Brass Alloy—an alloy more than double the tensile strength of cast iron—much stronger, harder and lighter in weight than ordinary white metal alloys. New dies have been produced for casting all parts. The new parts are solidly cast, and are very substantial and durable.

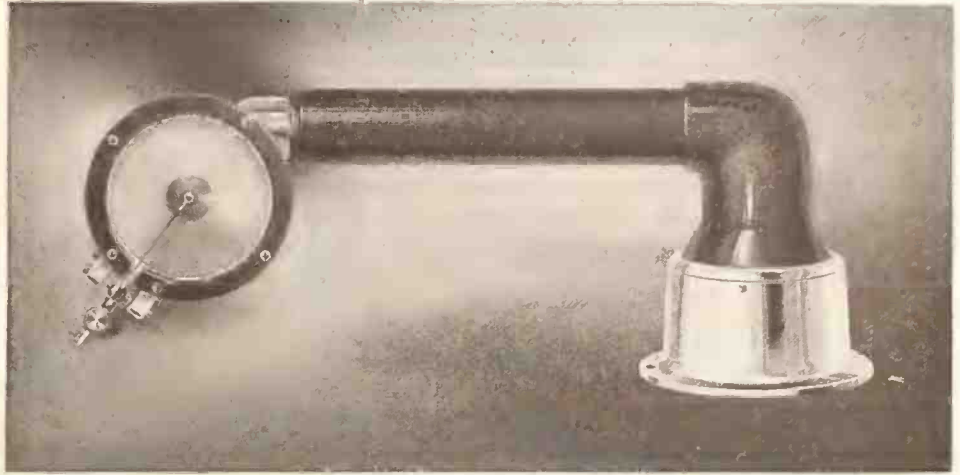

STYLE No. 1 FINISH

A combination of Nickel or Gold Plate and Black Rubber Japan

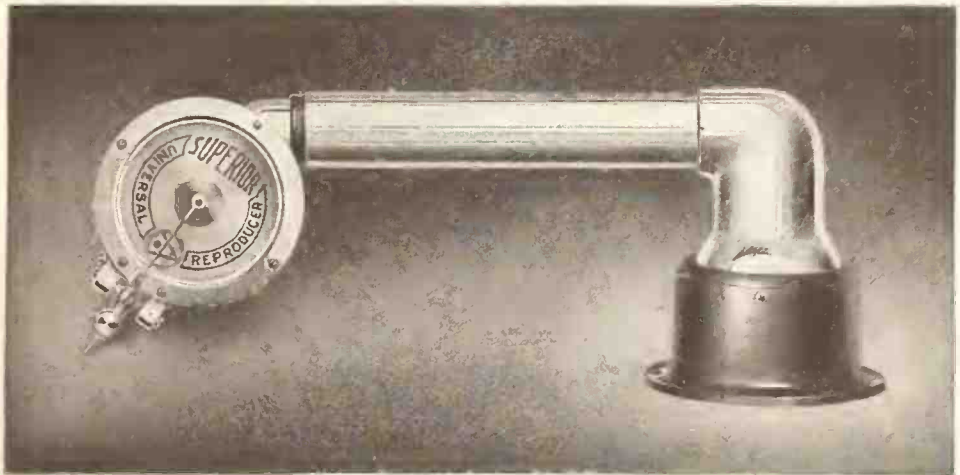

STYLE No. 2 FINISH

A different combination of Nickel or Gold Plate and Black Rubber Japan

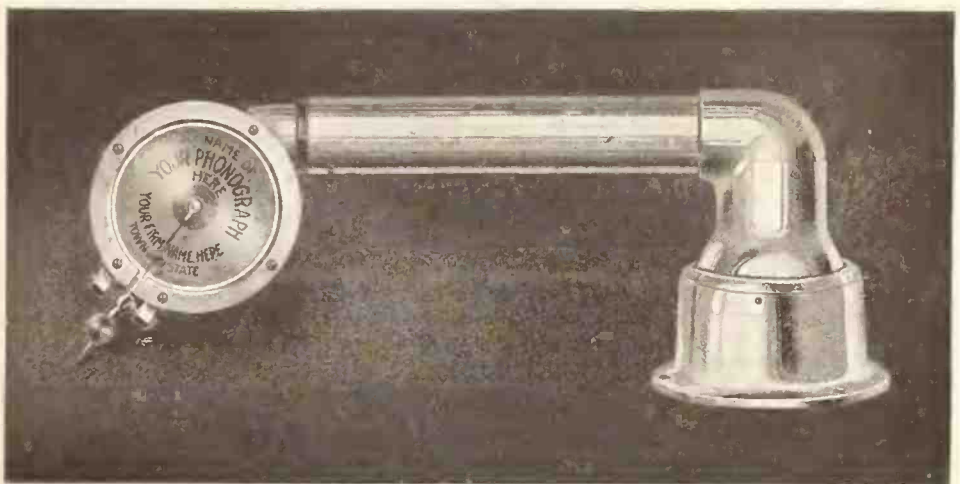

STYLE No. 3 FINISH

All parts Plated in Nickel or Gold

In ordering specify whether Reproducer should have Plain Gilt Plate or "Superior" Name Plate. To obtain Individual Name Plate, customer must furnish Decalcomania Transfer

Samples Will be Submitted on Approval

Style 1 Tonearm long tube and main elbow, Reproducer face ring and back Black Japanned; other parts Plated.

Style 2 Tonearm long tube and main elbow Plated, base Black Japanned; Reproducer back Black Japanned, the face ring and frame Plated.

Style 3 All parts of Tonearm and Reproducer are Plated.

- No. 1 New Scotford Tonearm and Superior Reproducer . Nickel \$7.00 Gold \$ 9.00
- No. 2 New Scotford Tonearm and Superior Reproducer . Nickel 7.75 Gold 10.00
- No. 3 New Scotford Tonearm and Superior Reproducer . Nickel 8.50 Gold 11.00

Samples Prepaid at the Above Prices

Write for Our Specification Sheet and Quantity Price List

BARNHART BROTHERS & SPINDLER

Monroe and Throop Streets

CHICAGO, ILLINOIS



The examples shown are by
 1—WILHELM FURNITURE CO.
 2—P. DERBY & SONS
 3—SHOWERS BROS.
 4—ELGIN A. SIMONDS
 5—PERU CHAIR WORKS
 A few of the many who consider "Domes of Silence"
 Standard Equipment for Furniture

YOU ARE SURE TO BE RIGHT when you tell your customers that
DOMES of SILENCE
 are the Perfect Furniture Footwear

Whether on the highest or lowest grade furniture they are equally as good. They protect the finest floors—rugs—
 and floor coverings. Hundreds of manufacturers who use them consider Domes of Silence Standard Equipment.

HENRY W. PEABODY & CO.
 17 STATE STREET NEW YORK CITY

Specify **DOMES OF SILENCE**

A mark of better furniture regardless of its cost

*What we say above about Furniture applies also
 to Phonographs*

Importance of Credits and Terms in Making a Talking Machine Store Pay :: :: By L. C. Lincoln

Adv. Mgr., Sonora Phonograph Co., New York

There is probably no factor in the talking machine business so vital, so vague, and followed so little along definite lines, as that of extending credit to instalment buyers. Time and again a rule will be laid down which is not to be overstepped, but special cases are constantly arising which seem to justify an exception. Some of the risks that appear the best frequently turn out to be the worst, and many that are doubtful at the outset cause no trouble at all to the dealer.

The lowest cash payment that should be accepted on a phonograph that is sold without records or other accessories is 15 per cent of the price of the instrument. The balance should be paid in equal monthly instalments ranging upward from 10 per cent per month on the balance.

A talking machine should not be sold to any person who cannot pay as a down payment an amount at least twice the sum of minimum monthly payments. People do not buy a phonograph on the spur of the moment, and, if they can raise no more money than an amount equal to the payment which they must make for a period of several months, after giving the subject sufficient thought to make up their mind to finally buy, they are an extremely poor risk.

Some dealers are inclined to accept payments on higher-priced instruments that are proportionately lower than those accepted on the cheaper machines. They will accept, for instance, no less than \$10 down and \$10 per month on a \$100 model, but may sell a \$300 model for \$30 down and \$15 per month.

It is their theory that a man who undertakes a \$300 obligation paying \$30 down is more inclined to fulfill it than one who will assume but \$100 at \$10 down and \$10 per month.

It is the belief of some dealers that the law of average is in favor of dealers who take a chance on every customer regardless of references, providing the customer is willing to agree to the required terms. Those who believe in this theory, however, are few.

It is a merchant's privilege to know the occupation and business address of purchasers; the name of the bank in which they have an account; the names and address of one or two relatives, and the names of any business houses that have had dealings with them in the past. The names of the relatives are handy in case the customer disappears.

No machine should be sold on payments unless secured by a chattel mortgage or a lien note contract. Every dealer should guard against delivering a machine to a customer who has agreed to pay for it before a lien has been signed by the purchaser, unless the dealer has positive information that the latter is financially responsible. Many people decline to sign away their rights even though the equity is slight, mostly because they are inexperienced in business customs, sometimes because they know more about such matters than the dealer and are trying sharp practices.

The dealer should be on the safe side and secure a signature to the agreement. It must be remembered that just as soon as a customer says "I'll take that machine," with a thorough understanding of the dealer's price and terms, the sale has been consummated in the eyes of the law and should the phonograph be delivered to the customer's house without his or her signature on a contract it cannot be forcibly removed for any reason. If the customer accepts the talking machine and fails to make any or all payments the dealer's only recourse is to sue and secure judgment. Even then it is possible that the judgment is not collected.

The best time to ask for reference is after the contract is signed and the first payment turned over to the salesman. The customer is

then not so likely to refuse the information. Under no consideration should a contract be accepted if the purchaser is unwilling to give the names of several responsible people with whom they are acquainted.

Many phonograph dealers before going into business for themselves were salesmen with some other establishment. Their training was along one line only—selling. A salesman is, naturally, ever anxious to please the customer, and follows the line of least resistance. He has learned by experience that the best way to get the customer's confidence in order to sell him goods is not to aggravate him, but to agree with him. He becomes so used to this fact that it is hard to break away from this manner of han-

dling customers. When it comes to the unpleasant duty of requesting and insisting on references, and other information vitally important to the safe conduct of the business, he is frequently bluffed by those who know that they cannot give satisfactory references and who adopt an air of injured pride and a manner that implies that the dealer is going too far.

Dealers who are handicapped by this failing will find that in most cases customers who have reached the buying point will not refuse legitimate information unless there are reasons, favorable to them but detrimental to the dealer. Moreover, it should be borne in mind that anyone buying on the lowest obtainable instalment

(Continued on page 50)



"The Instrument with the Human Throat"

THE COVERLEY



ALWAYS disliked the 'ice-box' in the drawing room! A cumbersome, blatant eye-sore, at odds with the furnishings and only fit to grind out sounds occasionally." Doesn't this express your customer's feeling toward the typical phonograph?

One would like a useful and authentic Period piece, say a Console and drop-leaf table of the type one takes pride in collecting—combined with the phonograph—if one could procure such. One can. Our new Georgian Periods are real furniture and are the only phonographs with the Vox Humana, a throat of carved wood, replacing "The usual piece of pipe."

We ask only that you see these new cases and hear one record played. These instruments will secure you more sales and we guarantee you more profits. Write us and we'll prove our statements.

THE MANOPHONE CORPORATION

4 West 40th Street
New York

MAKERS

Adrian
Michigan

IMPORTANCE OF CREDITS AND TERMS

(Continued from page 49)

terms is seldom so prominent a personage as to be justified in feeling humiliated.

Occasionally an attempt is made to purchase a machine which, in the dealer's opinion, is too great an obligation to be assumed by the purchaser. On such occasions the dealer usually induces the customer to buy a lower priced machine with the understanding that if it is paid for in contract time the higher priced machine may be selected and all money paid on the first machine applied on the new account. It can hardly be considered good business to do this, however, unless the purchaser is able to buy a machine that is at least double the price of the first one.

This brings to mind the fact that salesmen frequently attempt to induce customers to exchange a machine that was sold, say, for \$100 for one costing perhaps \$135. This is a mistake. Salesmen should never be permitted to induce customers to exchange a machine unless a sale can be made at an increase of 100 per cent. Customers should not be permitted to exchange a machine for one that is but slightly better unless it is in an attempt to save a sale.

SONORA JOBBERS VISIT NEW YORK

Quite a number of Sonora jobbers visited the company's executive offices in New York during the past fortnight to discuss general business conditions and to make arrangements for next year's activities. All of these visitors were optimistic in their reports regarding business conditions and substantiated this optimism by showing sales totals that compared very favorably with their banner years. Among these callers were: I. Montagnes, Toronto, Can.; Frank M. Steers, Magnavox Co., San Francisco, Cal.; Jos. H. Burke, M., S. & E., Boston, Mass.; E. S. White, Sonora Co., of Philadelphia, and C. L. Marshall, of C. L. Marshall & Co., Detroit, Mich.

Service
Dependable -- Constructive -- Intelligent

Putnam-Page Co.
Peoria, Ill.



"LONE STAR" LINE WELL RECEIVED

Texas Talking Machine Co. Establishing Important Agencies for "Lone Star" Machines and Records—Chain of Retail Stores a Success—Recording and Assembling Plants in Mexico

DALLAS, TEX., November 4—The Texas Talking Machine Co., of this city, which was formed in 1920 for the purpose of manufacturing the "Lone Star" phonograph, has attained exceptional success in the past year. The company has established dealers in the Southern half of the United States from the Atlantic to the Pacific, and new accounts are being closed regularly.

The company has so much confidence in the future of the talking machine industry that it has standardized a retail store for talking machines and records and has opened a chain of such stores through the South and Southwest. The first of these stores was opened in Dallas in August and since that time new establishments have been opened at regular intervals. These stores are under the management of A. E. Tompkins and are owned by a partnership consisting of W. L. Gleason and T. B. Thompson, who are also executives of the Texas Talking Machine Co.'s organization.

The company completed arrangements a few months ago, whereby the "Lone Star" record was added to its line. Recording laboratories are

located in Dallas and many of the best artists west of the Mississippi and in Mexico are making records for the "Lone Star" library. In addition, of course, there are the national popular artists and all of these records are being well received by the trade. The Texas Talking Machine Co. proposes to do its own recording in the City of Mexico to take care of the Mexican trade and will also erect an assembling plant in that city.

PLAYER-TONE EXHIBIT AT SHOW

I. Goldsmith in Charge of Player-Tone Display at New York Furniture Show—Carlot Orders

I. Goldsmith, president of the Player-Tone Talking Machine Co., Pittsburgh, Pa., spent ten days in New York recently, attending the New York Furniture Show. The Player-Tone Talking Machine Co. maintained an attractive exhibit at this show and Mr. Goldsmith stated that carload orders were received from a number of the leading retail houses in the East and West.

Commenting upon general business conditions, Mr. Goldsmith stated that there had been a phenomenal increase in sales since October 1. The Player-Tone factories are working to capacity and Mr. Goldsmith exhibited several telegrams from his customers asking him to make immediate delivery for carload shipments.

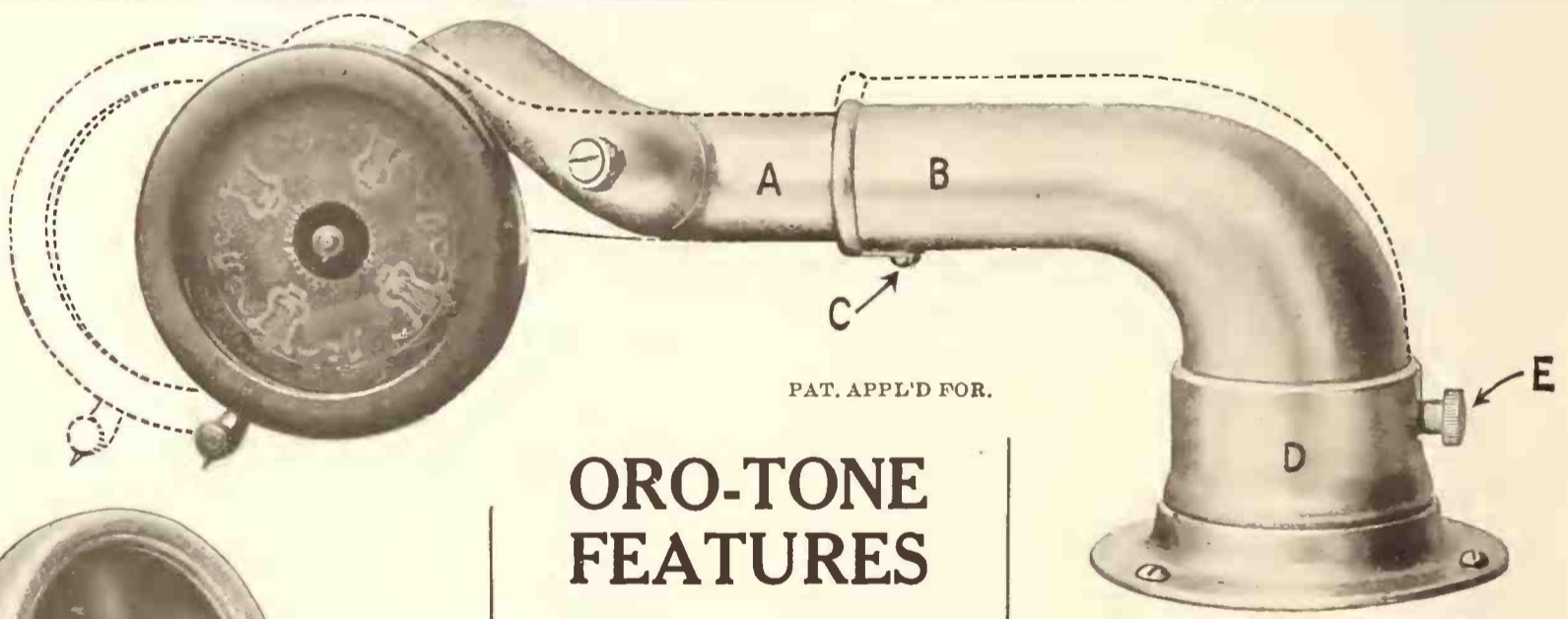

PAT. APPL'D FOR.

ORO-TONE FEATURES

Extension A telescopes into large elbow B, giving a length adjustment from 7¾ to 9½ inches. Adjustment screw C engages an indexed channel in extension A, assuring perfect alignment. Slightly releasing locking thumbscrew E permits height adjustment of large elbow in base ring D. Releasing locking screw E entirely permits tone arm to be removed from base ring D for packing separately before shipping, if desired.



MODEL L S

**COMPOUND
ROCKER
ACTION**

The highest grade and most scientific reproducer ever offered the trade.



PAT. APPL'D FOR.

Illustrating Angle Throw Back Improvement. Permits reproducer to clear tone arm when thrown back regardless of whether it is in position for playing Hill and Dale or Lateral-cut records.

ASK FOR ILLUSTRATED AND DESCRIPTIVE CATALOGUE

The Oro-Tone Co.
QUALITY FIRST

1000 to 1010 GEORGE ST.
CHICAGO, ILLINOIS

FEATURED ON OKeh Records

VIRGINIA

FEMALE

JUBILEE SINGERS



These records are the real camp meeting songs and represent a very old form of sacred music. The recording of the four selections is excellent.

The Virginia Jubilee Singers are so gifted with an unusually wide range of tonal color that they are capable of wonderful harmonies.

The bass singer has a voice of such full, rich quality and is so remarkable for its depth of tone that it is likened to a male bass.

Another singer has a lovely liquid soprano that places a great vigor of accent on her parts.

These records are the kind every one will like and will buy.

SPIRITUAL RECORDS

- | | | | |
|--------|---|---|---------------------------------|
| 4430 | } | O Mary, Don't You Weep, Don't You Mourn—Colored Quartette | Virginia Female Jubilee Singers |
| 10-in. | | | |
| \$.85 | } | Lover of the Lord—Colored Quartette - - - | Virginia Female Jubilee Singers |
| | | | |
| 4437 | } | Go Down Moses, Way Down in Egypt Land--Colored Quartette | Virginia Female Jubilee Singers |
| 10-in. | | | |
| \$.85 | } | When Jesus Christ Was Born--Colored Quartette | Virginia Female Jubilee Singers |
| | | | |

General Phonograph Corporation

OTTO HEINEMAN, President

25 West 45th Street - - - New York



H. N. McMenimen Consulting Engineer

Consultation by appointment on every phase of the phonograph industry, including:

Recording, Plating and Pressing

Motor, Tone-Arm and Reproducer Design

Patent and Model Development

Sales Promotion and Advertising Plans

Laboratory:

Scotch Plains, N. J.
Tel. Fanwood 1438

Offices:

2 Rector Street, New York
Tel. Rector 1484

BIG ADVERTISING CAMPAIGN

Columbia Dealers to Be Featured in Extensive Newspaper Advertising

Lester L. Leverich, advertising manager of the Columbia Graphophone Co., announced recently the completion of plans for one of the most far-reaching and important newspaper advertising campaigns that has ever been launched in the talking machine industry. This campaign started October 14 and will continue until Christmas.

According to Mr. Leverich's schedule, 250 newspapers will be used in the campaign, comprising papers published in every Columbia branch territory. The copy will consist of a space measuring seventeen inches across five columns and every single piece of copy will list the names and addresses of Columbia dealers in their respective localities.

H. S. HOLLY TO JOIN GUERTH FIRM

REDLANDS, CAL., October 24.—H. S. Holly, formerly proprietor of one of the largest music establishments in Iowa, will be associated with William C. Guerth, proprietor of a large music business in this city. Mr. Holly is planning to take over part of the talking machine business.

It has well been said that success is a slow traveler—more people overtake it than are overtaken by it.

Warbletone Record Renewer

Cleans and polishes old records and makes them sound and look like new.

Cleans the grooves and the general surface, removing dust, grit and foreign matter without the least injury to the sound grooves themselves.

This new invention gives new voice and renewed tone to records and will positively clarify articulation.

One bottle will last indefinitely. Very simply applied.

Immensely valuable to dealers as well as to machine owners. "2 drops to a record."

If your jobber cannot supply you order direct. Price 50 cents per bottle retail. Liberal discounts.

WARBLETONE MUSIC CO.
225 Massachusetts Ave. INDIANAPOLIS, IND.

FINE NEW SHOP IN AKRON, O.

New Talking Machine Department of House of Dales Is Unusually Attractive

AKRON, O., November 4.—Rivaling any shop of its kind in this section, the new Howard street talking machine department of the House of Dales has been completed and congratulations are being showered upon the enterprising music house for the creation of such a unique store.

R. A. Porter, manager of the music department of the Dales Co., told The World representative that many months have been devoted to the carrying out of plans and the development of the talking machine section. The new section has the appearance of a grill, is located in the basement, with entrance from the main floor via elevator, and is accessible from Howard street. The decorative scheme throughout is polychrome and around all the walls are paintings, which add much to the artistic appearance of the department. Twelve individual sound-proof booths have been installed, each furnished with home

appointments and all conveniences for the patrons. A Japanese reception room is another feature. A large homelike fireplace in one corner sets off the new room to a great advantage. All the decorations were designed by M. Schulz. The furniture is wicker with attractive cretonne upholstery.

This division is separate from the main music floor, which is located upstairs over the jewelry department, which is accessible from South Main street. In this department there are ten elegantly furnished booths and a large concert room.

The company still maintains its exclusive Brunswick store in South Main street, and business there is reported to be holding up well. Only talking machines are carried, but it is planned to add piano lines later, according to Mr. Porter.

The Colvin Colwell Co., Troy, N. Y., has been incorporated with capital stock of \$15,000 to deal in talking machines and pianos. The incorporators are E. D. A. Colvin and J. H. and A. A. Colwell.

Study the SILENT Motor

Its Advantages for Your Line of Talking Machines Are Self-Evident

Over 300,000 in Actual Use

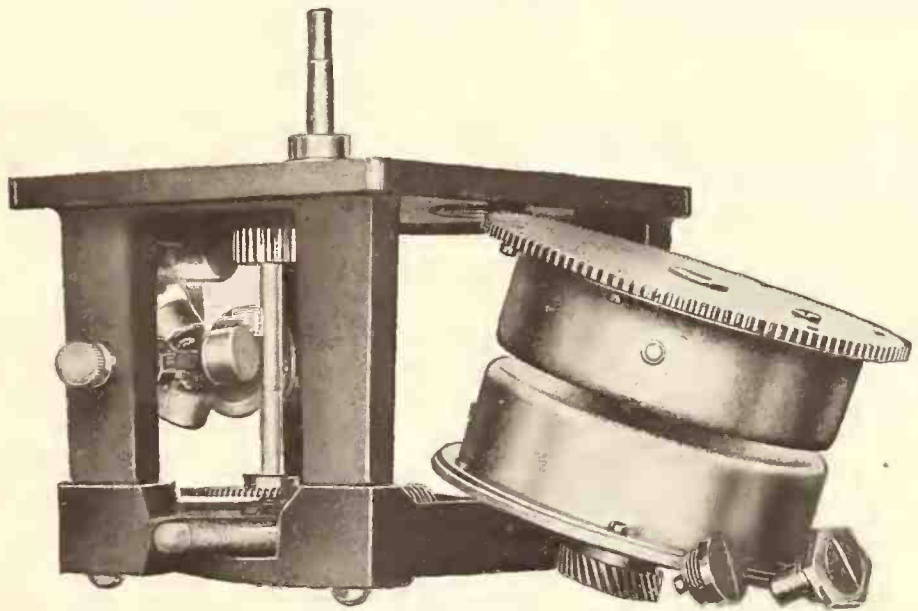

The Silent Motor With Spring Barrels Demounted. Note the Sturdy and Simple Construction.



An Exclusive
SILENT MOTOR Feature.

Self-aligning governor shaft, mounted on universal ball-and-socket bearing. Eliminates governor trouble forever.

Send for Sample and Prices

THE SILENT MOTOR CORPORATION

CHARLES A. O'MALLEY, President

321-323-325 Dean Street,

BROOKLYN, N. Y.

Okeh Records



Everyone Is Dancing

Now is the time to order that contemplated stock of *Okeh* hits.

The records with new sparkling rhythms, melodiously played, are the dancers' first choice. They get them on. *Okeh* Records.

The holiday season is approaching, gay musical festivities will begin in the homes.

Okeh Records are the very thing for these gala occasions.

Be prepared for requests from those particular in their selection of classical records.

Our celebrity records are examples of the highest craftsmanship in recording. Every artist has a reputation internationally recognized.

These records will secure for you their spontaneous patronage, and give you satisfied customers.

Enlarge your stock of opera selections with the *Okeh* label.

Consolidated Talking Machine Co.

227 W. Washington St.

Chicago, Ill.

Okeh Record Distributors

COLUMBIA NOVEMBER DISPLAY

Symphony Music the Basis of Very Artistic Window Display for Dealers' Use

The Columbia window display for November has been built around symphony music, as the company's Dealer Service department felt that this was timely, in view of the opening of the concert and operatic season in October and November.

The centerpiece has been given over to a strong illustration of Stracciari, singing "Vile Race of Courtiers" from "Rigoletto," a symphony record that is very popular. For the two major side pieces the "Samson and Delilah" selection, sung by Jeanne Gordon, and the "Intermezzo," from "Cavalleria Rusticana," played by Gino Marinuzzi and his Symphony Orchestra,



The Latest Columbia Window Display are used. These three units make in themselves a very strong symphony display.

The three remaining units have been given over to the popular artists and make a strong popular group for use on the tenth of the month, at the time when these featured records come out. Supplementing the display is also a special artist poster on Rosa Ponselle with a special window streamer to be used during Ponselle week.

This month there is an innovation and departure from the policy laid out before and now each card features only a single record, instead of a list of records.

LEAVES ON EXTENDED TRIP

Halsted Williams on Western Trip—Company's Products Meeting With Success

O. H. Williams, general manager of the Halsted Williams Corp., Brooklyn, N. Y., manufacturers and distributors of stock record envelopes, record supplement envelopes and record delivery bags, left recently on an extended trip in the interest of the new Christmas record gift bag which the company announced to the trade last month. Mr. Williams plans to call on dealers and wholesalers in New York State and the large cities of the Middle West, returning by way of Pittsburgh and Philadelphia. Orders for this Christmas gift bag are being received daily from all sections of the country and Mr. Williams states that the Halsted Williams products are meeting with gratifying success.

OPEN GRAFONOLA DEPARTMENT

The Farrar Furniture Co., of Bangor, Me., has opened a Grafonola department, which is located on the right of the entrance, where special space has been provided to fit in with the decorative scheme.

IS YOUR RECORD GOOD?

ALL MANUFACTURERS OF
GOOD RECORDS
ARE USERS OF OUR

COTTON FLOCKS

Claremont Waste Mfg. Co., Claremont, N. H.

IMPROVED CONDITIONS IN GEORGIA

Better Prices for Cotton Create Feeling of Optimism and Buying of Talking Machines and Records Is Increasing—The News of Month

ATLANTA, GA., November 7.—Conditions in the talking machine and record trade in this city show steady improvement, owing to the material advance in cotton during the past two months. There is still quite a hesitation evident among buyers because the feeling prevails that talking machine prices may come down. One of the leading concerns which has reduced prices of machines has benefited materially by increased wholesale and retail sales.

The Goodhart-Tompkins Co., Victor dealer, has secured the services of Forrest Traylor as manager of its Victor department. Mr. Traylor was for some years manager of the music department of the Castner-Knott Dry Goods Co., Nashville, Tenn., and has an enviable record as a successful producing manager.

Julian Prade, Brunswick retailer, is having quite a nice business. He has been a phonograph dealer only a few months and is well pleased with the line and the business he is securing.

George W. Hopkins, vice-president and general sales manager of the Columbia Co., was in the city the latter part of October and had a conference with the managerial and sales forces of the local Columbia organization. It is understood that Mr. Hopkins found the Atlanta branch conditions in a good, healthy state.

The Myers-Miller Furniture Co., Columbia dealer, recently held a "carload sale" of Grafonolas and was quite pleased with the volume of sales in machines and records secured in this manner during a drive of one week.

President Harding, Mrs. Harding and party were visitors to the city October 27. The President was given an old-time Southern ovation. It has been nearly fifteen years since a Republican President visited the Southeast.

The Phillips & Crew Piano Co., Victor dealers and agents for the Steinway piano, had one of the most artistic window displays recently that your correspondent has seen in some time. The window was decorated with autumn leaves and flowers. This concern is particularly well equipped for retailing talking machines and is doing quite a satisfactory business in practically all the Victor styles.

The following dealers or branches report business as improving: Columbia (W. Terhune, branch manager), Victor (Elyea Co., dealer), Sonora and Emerson records (Southern Sonora Co., E. D. Upshaw, president), Brunswick-Balke-Collender Co. (Southern branch).

"MOVIE STARS" WHO OWN SONORAS

Magnavox Co. Furnishes Sonora Sales Division With Important List—Sonora Is Popular With "Movie" Artists, Judging From the Poster

The sales department of the Sonora Phonograph Co., in New York, received last week an interesting communication from the Magnavox Co., Sonora jobber of San Francisco, commenting upon the fact that this jobber had noticed recently the names of several prominent movie stars in the East who had purchased Sonoras. The Magnavox Co., with customary Western loyalty, furnished the Sonora sales division with a list of some of the famous motion picture artists on the Coast who have purchased Sonora phonographs recently.

This list, which reads like a blue book of the motion picture industry, is as follows: Gladys Brockwell, Lon Chaney, Charlie Chaplin, Betty Compson, Ola Cronk (Bess Windsor), James Cruze, Bebe Daniels, Carter DeHaven, Chas. Eyton, Douglas Fairbanks, Magdalene Fayton, Cecil B. DeMille, Gish Sisters, Louise Glaum, David W. Griffith, Bill S. Hart, Herbert Hayes, Mildred Harris, Phyllis Haver, Thos. H. Ince, Geo. Melford, Tom Mix, Katherine MacDonald, Mme. Nazimova, Mabel Normand, Mary Pickford, Charles Ray, Wallie Reid, Anita Stewart, Mack Sennett, Ben Turpin, Maurice Tourneur and Clara Kimball Young.

GET THESE FOR XMAS

Immediate Shipments

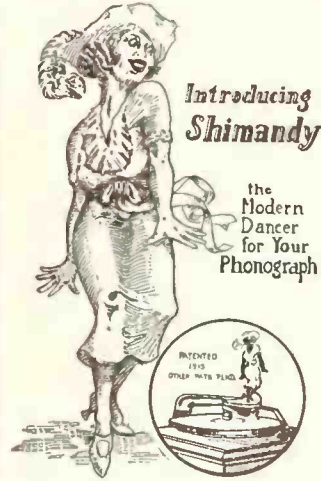

Start Shimandy Shimmying in Your Window and You Start Business Coming In Your Door

Shimandy Sells Herself and Sells Records Too

Repeat order for one gross from customer who had Shimandy just 3 days.

Dealer writes—"Shimandy is some doll—we placed her in our window and had crowds all day."

Shimandy has a classy silk dress, a silk hat with white plume and does many different Jazz and Shimmy steps.

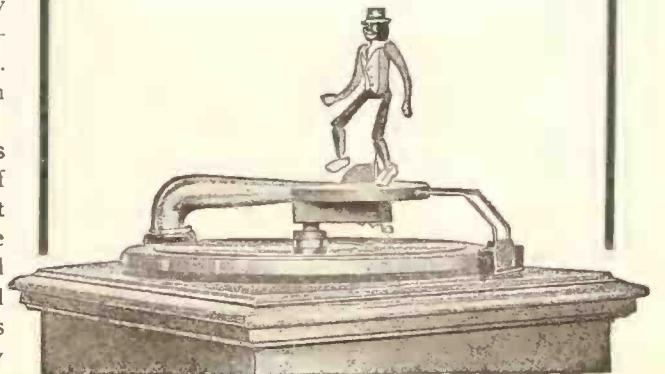

RAGTIME RASTUS
PATENTED MARCH 16, 1915.

An Automatic Dancing Doll for Phonographs

Rastus dances one hundred different steps while the music is playing. Delights children and amuses the older people, too. Attractively painted in four colors. Dances well to any lively record.

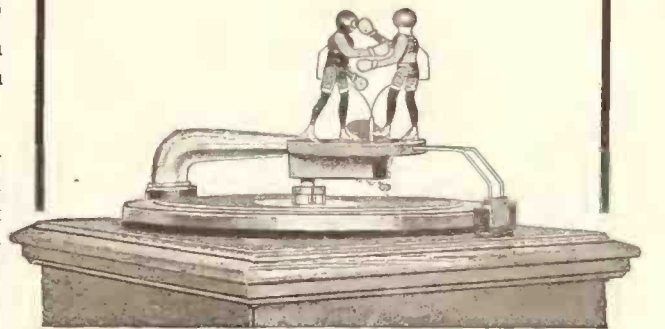

THE BOXERS
Patented March 16, 1915

These little Boxers are very realistic and create lots of fun. Put on a good lively record and these little men box away with wonderful speed and accuracy. The figures are attractively hand painted in several colors.
NOTE: These Toys can be put on or taken off in five seconds. Fit all Columbia, Victor or other standard machines. (Edison machine with thick records requires our special driving disk. 25 cents extra.)

Prices and Discounts

- Ragtime Rastus—Item 100-A.....\$1.50
- Boxing Darkies—Item 100-B..... 1.75
- Combination Rastus and Boxers, the two sets of figures and one dancing mechanism, in one box—two toys in one. Item 100-A-B..... 2.00
- Shimandy—Item 100-D..... 2.00
- Combination Rastus, Boxers and Shimandy figures and one dancing mechanism in one box—three toys in one. Item 100-A-B-D.....\$3.00

Trade and Export Discount

In less than 3 dozen lots of one kind or assorted 33 1-3%.
In 3 dozen lots or more, 40%.

Immediate Shipment

National Company
Cambridge Sta. 39, Boston, Mass.



JUST IN TIME FOR Holiday Business

NEW RELEASES OF STANDARD SELECTIONS



RECORDS Needle Played

Duplicated from the famous Pathé Library and possessing that incomparably beautiful and mellow tone characteristically Pathé.

Many of the numbers you will need immediately for holiday demand, and all of a type which must have representation in the stock of the progressive dealer.

NO "DEADWOOD" IN THIS LIST

RECORDS FOR THE CHRISTMASTIDE

- 022433 { CHRISTIANS AWAKE, SALUTE THE } Shannon Four
Leucocyte { HAPPY MORN } (Male Quartet)
85c { God Rest Ye Merrie Gentlemen..... }
 - 022432 { EXCELSIOR (Balle)..... } Lewis James and Elliott Shaw
Leucoma { The Voice of the Chimes..... } Acme Male Quartet
85c
 - 020472 { HOW SANTA CLAUS MAKES HIS TOYS } Gilbert Gerard and
Leuconic { How Santa Claus Distributes His Toys. } Russell Hunting
85c
 - 022191 { CHRISTMAS EVE IN THE TOY SHOP } Russell Hunting and Sterling Trio
Leucosin { 'Twas the Night Before Christmas..... } Russell Hunting
85c
 - 029219 { ADESTE FIDELES (OH, COME ALL YE FAITHFUL) } Shannon Four
Levator { The Holy City..... } Helen Clark
\$1.25
 - 040058 { HARK, THE HERALD ANGELS SING..... } Tempo Male Quartet
Levee { While Shepherds Watched Their Flocks }
\$1.25 { By Night..... }
 - 040186 { SILENT NIGHT, HOLY NIGHT... } Mendelssohn Mixed Quartet
Leveler { It Came Upon the Midnight Clear (Sears-Wills)... } Charles Hart
\$1.25
 - 022401 { JESUS I COME..... } Lewis James and Harold Wiley
Lepodite { Leaf By Leaf the Roses Fall... }
85c
 - 022461 { "ALMOST PERSUADED" AND "ALL HAIL THE POWER" } Lyric Male Quartet
Lepothrix { "Whiter Than Snow" and "Only a Step to Jesus" }
85c { Cathedral Quartet }
 - 020342 { THE CHURCH IN THE WILDWOOD } Chautauqua Preachers'
Leptandra { When the Roll Is Called Up Youder... } Quartet
85c
 - 022084 { LITTLE DAVID PLAY ON YOUR HARP } Noble Sissle and Serenaders
Leptiform { Exhortation }
85c { Creighton Thompson and Europe's Singing Serenaders }
 - 020241 { BEAUTIFUL ISLE OF SOMEWHERE..... } Sterling Trio
Leptilon { Beulah Land..... } Marian Crawford
85c
 - 022054 { THE SWEET STORY OF OLD..... } Earle Wilde
Lepton { What a Friend We Have in Jesus!..... } (Tenor)
85c
 - 025050 { THE PALMS } Percy Hemus
Lentour { The Resurrection } (Baritone)
\$1.00
 - 022431 { SHEPHERD, SHOW ME HOW TO GO..... } Robert Bruce
Leopard { O'er Waiting Harpstrings..... } (Tenor)
85c
- COMEDY AND NOVELTY SELECTIONS**
- 022151 { SLEEP, BABY, SLEEP..... } Matt Keefe
Leucite { The Strolling Yodler..... } (Yodler)
85c
 - 022223 { COHEN GETS MARRIED } Monroe Silver
Leucin { Cohen On His Honeymoon..... } (Monologist)
85c
 - 022224 { TRAIN TIME AT PUN'KIN CENTRE, } Cal Stewart
Leucifer { UNCLE JOSH } (Monologist)
85c { Uncle Josh and the Honey Bees, Uncle Josh }
 - 022252 { PICK 'EM UP, SILAS, LAY 'EM DOWN, ZEKE... } Cal Stewart
Lettiga { Uncle Josh and Aunt Nancy, etc..... } Stewart and Ada Jones
85c
 - 022417 { MEDLEY OF COUNTRY REELS..... } J. Samuels
Lettize { Medley of Country Jigs..... } (Violinist)
85c
 - 022477 { SPRING SONG, "WHISTLING SOLO"..... } Margaret McKe
Lettired { The Star } Whistler
85c

- 029125 { THE LAUGHING } Billy Golden and Jim Marlowe
Lottoff { FABRICATORS } (Comedians)
\$1.25 { The Insect Powder Man..... }
- OPERATIC ARIAS**
- 020323 { LITTLE MOTHER OF MINE..... } Lewis James
Lougham { Come Where My Love Lies Dreaming..... } (Tenor)
85c
 - 022259 { BYE LO } Sterling Trio
Leucitoid { Let the Rest of the World Go By..... } James and Hart
85c
 - 022459 { BEDOUIN LOVE SONG..... } Wilfred Glenn
Lentive { Dreams } (Basso)
85c
 - 022175 { A DREAM } Charles Harrison
Lennert { The Old Refrain..... } (Tenor)
85c
 - 025004 { SILVER THREADS AMONG THE GOLD..... } Craig Campbell
Lentitude { We've Been Chums for Fifty Years..... } (Tenor)
\$1.00
 - 025046 { MARGUERITE } Percy Hemus
Lentent { Afterwards } (Baritone)
\$1.00
 - 020124 { A PERFECT DAY..... } Harry McClaskey
Lenture { Carry Me Back to Old Virginia..... } Campbell and Burr
\$1.25
 - 010133 { ALOHA OE..... } Marie Morrissey and Invincible Four
Lentisk { Dreams } Marie Morrissey
\$1.25
 - 040146 { ANNIE LAURIE } Shannon Four
Lenticel { Ye Bank and Braes O' Bonnie Doon..... } Lewis James
\$1.25
 - 010167 { HOME SWEET HOME..... } Helen Clark
Lenten { Darby and Joan } (Contralto)
\$1.25
- INSTRUMENTAL, BAND AND ORCHESTRA SELECTIONS**
- 020149 { KAMEHAMEHA MARCH } Louise and Ferera
Leshalom { Honolulu Hulas } (Hawaiian Guitars)
85c
 - 020212 { HAWAII AND YOU..... } William Wheeler, Hawaiian Accomp.
Letgame { The Glow-Worm..... } Louise and Ferera, Walkiki Orch.
85c
 - 020253 { 2ND REGIMENT CONNECTICUT N. G..... } American
Leptuntic { American Republic March..... } Regimental Band
85c
 - 020345 { AMERICAN PATROL } Boudini Brothers
Lessing { Iliam's Huskin' Bee..... } (Accordionists)
85c
 - 022045 { NATIONAL EMBLEM MARCH... } American Regimental Band
Lernaea { Hail to the Spirit of Liberty!... }
85c
 - 022073 { WALTZ LLEWELLYN—Saxophone Solo..... } Rudy Wiedoeff
Lesche { Serenade—Saxophone Solo..... } (Saxophonist)
85c
 - 022092 { IRISH MEDLEY OF REELS, No. 1 } Boudini Brothers
Lesee { Accordion Duet } (Accordionists)
85c { Irish Medley of Jigs, No. 2 Accordion Duet }
 - 022182 { HUMORESQUE } Boudini Brothers
Lerruck { Danube Waves—Waltz } (Accordionists)
85c
 - 027037 { THE SONG OF VOLGA..... } Russian Symphony Orchestra
Lerol { Entree Triomphale Des Boyards }
85c
 - 040091 { JOFFRE MARCH } American Regimental Band
Lerrett { Army Bugle Calls..... }
\$1.25

- 059092 { MAZURKA IN E FLAT..... } Rudolph Ganz
Lesson { Nocturne in E Flat..... } (Pianist)
\$1.50

OPERATIC ARIAS

- 054005 { CARMEN, "AIR DE LA FLEUR"..... } Lucien Muratore
Legume { }
\$1.50
- 054061 { I PAGLIACCI, "PROLOGUE"..... } Adamo Didur
Leopus { }
\$1.50

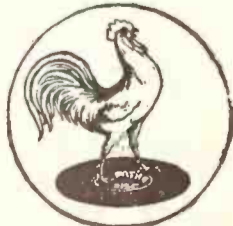



UP-TO-THE-MINUTE

Releases of Popular Hits

ALSO SOME ADDITIONAL "STANDARDS"

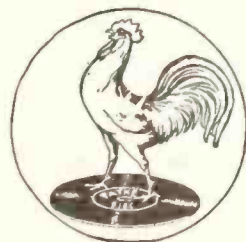

RECORDS

Sapphire Played

December releases of Actuelle (needle played) and Pathe' (sapphire played) records

Get additional record business! It's waiting for you! Pathé is showing you how by giving you, to supply against demand, not only Pathé sapphire played, but Actuelle needle played records which will play on any talking machine.

In both the Actuelle and Pathé Libraries releases are made simultaneously each month of the best selling up-to-the-minute popular vocal and dance selections, plus always some of the old favorite "standards" for which constant call exists.

NOTE: Actuelle records (needle played) are identified by prefix "0" to record number

- 020630 } **SAY IT WITH MUSIC**—Fox-trot.....Casino Dance Orchestra
Narcotic 20630 }
Narcosis 85c } Apache Love—Fox-trot.....Joseph Samuels' Music Masters
- 020628 } **YOO-HOO**—Fox-trot
Nappe 20628 } Ernest Hussar and His Hotel Claridge Orchestra
Napoleon 85c } When the Honeymoon Was Over—Fox-trot
Joseph Samuels' Music Masters
- 020633 } **SWEET LADY**—Fox-trot }
Narifonn 20633 } } Markels' Society Orchestra
Narial 85c } } Dream—Fox-trot }
- 020632 } **TENDERLY**—Fox-trot }
Nargil 20632 } } Merry Melody Men
Nares 85c } } Bimini Bay—Fox-trot }
- 020629 } **MISSISSIPPI CRADLE**—Waltz }
Narcaine 20629 } } Green Brothers' Novelty Band
Napping 85c } } I Want My Mammy—Fox-trot }
- 020631 } **IT MUST BE SOMEONE LIKE YOU**—Fox-trot
Narcotism 20631 } Joseph Samuels' Music Masters
Narcotine 85c } I Wonder If You Still Care for Me—Fox-trot,
Markels' Society Orchestra
- 020638 } **THREE O'CLOCK IN THE**
Narwhal 20638 } } MORNING—Waltz }
Narthez 85c } } Moon River—Waltz }
De Pace Bros. } (Mandolin and Guitar) }

- 020634 } **WANG WANG BLUES**—Fox-trot.....The Seven Black Dots
Narrante 20634 }
Narra 85c } Shake It and Break It—Fox-trot..Lanin's Southern Serenaders
- 020625 } **CRY BABY BLUES**—Dance Rhythm.....Ernest Hare
Napery 20625 }
Nankeen 85c } I Ain't Nobody's Darling.....Byron G. Harlan
- 020626 } **PLANTATION LULLABY** Crescent Trio
Naphthide 20626 }
Naphthene 85c } Down in Happy Valley.....Charles Hart and Elliott Shaw
- 020639 } **WHEN FRANCIS DANCES WITH ME**..... }
Nasicorn 20639 } } Patricola
Nascence 85c } } I Ain't Gonna Be Nobody's Fool..... }
(Comedienne)
- 020627 } **HE TOOK IT AWAY FROM ME**—
Naphin 20627 } } Dance Rhythm }
Naphthol 85c } } If I Were Your Daddy (And You }
Were a Mamma to Me)— }
Lavinia Turner and James }
P. Johnson's Harmony }
Seven }
- 020635 } **MY PRETTY JANE**
Narrative 20635 } } (The Bloom Is on the Rye)..... }
Narration 85c } } Sweet Genevieve }
Charles Harrison }
- 020607 } **MAH LINDY LOU**..... }
Voyageur 20607 } }
Voyage 85c } } Mighty Lak' a Rose..... }
Llora Hoffman }
- 020637 } **ANVIL CHORUS**
Narrowing 20637 } } (From "Il Trovatore") (Verdi)..... }
Narrower 85c } } The Jolly Coppersmith (Peters)—March..... }
Empire State }
Military Band }

A few related numbers from the many in the Pathé Library, which will sell especially well during the holiday season

- 52045 } **NOEL**..... } Percy Hemus
\$1.50 } Star of Bethlehem..... }
- 62005 } **LA CHARITE** (in French)..... } Note
\$2.50 } Noel (in French)..... }
- 54058 } **SILENT NIGHT, HOLY NIGHT**.....Margaret Matzenauer
\$1.50 }
- 40309 } **MARCH OF THE TOYS**, from }
"Babes in Toyland"..... } Waldorf-Astoria Concert Orch.
\$1.25 } Habanera (Chahrier)..... }

- 20452 } **OH, COME, ALL YE FAITHFUL**..... } Pathé Military Band
85c } Hark, the Herald Angels Sing..... }
- 49204 } **CHRISTMAS SPIRIT**..... }
\$1.25 } Christmas Chimes..... } Harmony Orchestra
- 1065 } **OH TANNENBAUM**..... } Chor Der Oper, Berlin
85c } Stille Nacht, heilige Nacht..... }
- 1066 } **ZU BETHLEHEM GEBOREN**..... } Chor Der Oper, Berlin
85c } Eine feste Burg..... }

The Forward Looking Dealer

Who has not yet done so will immediately investigate the profit bearing potentialities of a Pathé agency. From such, communication is invited.

PATHÉ FRÈRES PHONOGRAPH COMPANY

BROOKLYN, N. Y.

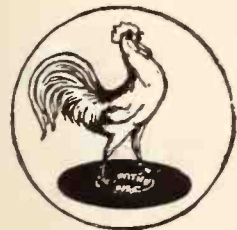

THE GREATEST MUSICAL HIT OF AGES

The SONG OF LOVE

From "BLOSSOM TIME"

ASK TO HEAR IT!

"You can't go wrong with any Feist song"

ANNOUNCES NEW LIBRARY MODEL

Geo. Clay Cox Adds New Type of Library Table Phonograph to Line—Equipped With Phonomotor and Phonostop and Has Several Distinctive Features of Interest

ROCHESTER, N. Y., November 7.—Geo. Clay Cox, of this city, has just placed on the market a new type of library table phonograph which is attracting considerable attention. This model is unique owing to the fact that it is not necessary to raise the top of the machine in order to play it, which is a common feature of the ordinary type of library table phonograph.

All of these new models are equipped to run with the electric Phonomotor, an additional part of the equipment being the well-known "Phonostop." Its mechanism is so arranged that after placing the record on a turntable the motor is started automatically, playing the record to the end and stopping automatically. Dealers speak highly of the new library model.

REGINA CO. IN RECEIVERS' HANDS

Receivers Directed by the Court to Continue the Business for Thirty Days

RAHWAY, N. J., November 5.—Willis J. Desnoyer, president of the Regina Co., one of the oldest music box and talking machine manufacturing concerns in the country, and John A. Bernhard have been appointed receivers for the company under a \$50,000 bond. The receivers have been directed to continue the business for thirty days and report results to the court. The petition for the receivership was filed by three creditors. Liabilities are stated at \$825,000 and assets are approximately \$500,000.

Results that count these days are secured by salesmen who know their business thoroughly—who can build up sales by their individual knowledge of good music and an acquaintance with the history and accomplishments of the artists who make records.

TALKS ON MUSIC TO ROTARY CLUB

Miss Streeter, of Victor Co. Educational Staff, Lectures Before Indianapolis Club

INDIANAPOLIS, IND., October 25.—Through the efforts of J. B. Ryde, of the Fuller-Ryde Music Co., Miss Margaret Streeter, educational director from the Victor factory, spoke before the Indianapolis Rotary Club at a weekly meeting on "Universal Need of Music Appreciation." The address was received with much favor and the Fuller-Ryde Co. obtained favorable publicity, both at the meeting and through the advance notices of the meeting. Mr. Ryde had charge of the program and utilized the school Victrola as an aid in the program. A large crowd attended the lecture.

The Lilly Drug Co., Mansfield, Mass., recently opened an attractive new Victor talking machine department under the management of Frank Goulart.

Another 10% reduction to help you clean out Victrola IX's this Christmas



No. 1402

Overcome selling resistance to table type Victrolas by combining them with Udell Record Cabinets. These two Udell models with the patented hinged rim are now priced to you so that you can sell either with a Victrola IX for less than \$100 and make your usual Victor profit on both pieces.

The next sixty days is your time to sell these IX's. Wire your order today for two or three of each piece.

No. 1402
Made in either mahogany or quartered oak. Holds eight Victor albums. The cut only indicates its superior appearance.

\$12.15
F.O.B. INDIANAPOLIS

No. 1410
In either mahogany or quartered oak. Holds five Victor albums. Average weight, crated, 65 pounds. Well made. Substantial.

\$10.80
F.O.B. INDIANAPOLIS

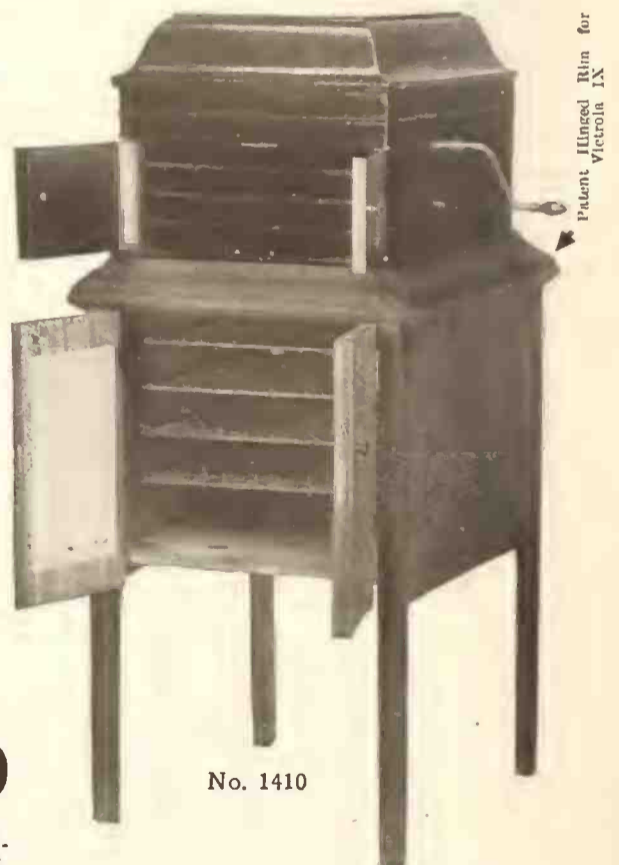

No. 1410

Wire your order collect for either of these pieces

The UDELLWORKS

1310 WEST 28th STREET, INDIANAPOLIS

10% reduction on last price list on all Udell Record Cabinets.

FROM SALESMAN TO VICTOR ARTIST

I. Leonard Braun Realizes Ambition in Victor January Releases—Formerly Associated With Grinnell Sales Staff—Well Known as Composer

The January releases of Victor records will include two selections by I. Leonard Braun, tenor, who was identified with the Victor retail trade for nine years as a member of the retail staff of Grinnell Bros., Detroit. When he joined the Grinnell staff Mr. Braun decided that he would not only sell records, but would also make them, and he thereupon started the study of voice culture and composition. During his association with Grinnell Bros. he gained a deeper appreciation of those great artists whose musical interpretations can best be understood and studied through the talking machine and the January Victor list realizes Mr. Braun's ambitions.

The Victor record by Mr. Braun features two of his own musical arrangements, one being



I. Leonard Braun

"Zion, My Holy Land," a Zionist number, the English version of which was recently written by the great poet, Edgar A. Guest, and on the reverse side is "My Little Boy," by another well-known American poet, Morris Rosenfeld.

Mr. Braun has also composed the ritual, initiation music for the Order B'nai B'rith of America, for which organization he has trained several glee clubs, including one in New York City, consisting of forty members. Besides teaching a class in Detroit Mr. Braun is at present engaged in composing music and is studying a large repertoire for additional recordings.

NEW BRUNS COVER ON MARKET

Waterproof Delivery Cover Added to Bruns Line—New Distributors Appointed

A. Bruns & Sons, Brooklyn, N. Y., manufacturers of the Bruns "Maderite" cover for talking machines, are introducing to the trade a new rubberized waterproof cover that is meeting with favor with dealers everywhere. It embodies the features which have made the Bruns "One-man" cover popular, and in addition has been constructed along altogether new lines. It is so made that the cover of the talking machine can be raised at will without removing the cover from the rest of the machine. This distinctive feature is the result of a thorough study of the needs of the dealer and, as Mr. Bruns states, is a forward step in the manufacture of delivery covers for talking machines.

Several new distributors have been appointed throughout the country to handle the Bruns cover, the latest of which are: The Florida Talking Machine Co., Jacksonville, Fla.; the Talking Machine Co. of Texas, Houston, Tex.; Putnam-Page Co., Peoria, Ill.; Buffalo Talking Machine Co., Buffalo, N. Y., and the Cabinet & Accessories Co., New York City.

Unanimous declaration in favor of the use of pictures in advertisements was the result of the questionnaire sent by the National Retail Dry Goods Association to twenty-two leading merchants.

WINS ATTENTION WITH ODD FLOAT

Snyder Music Co., Wilkes-Barre, Pa., Mounts Monster Bass Drum on Float for Parade

The Snyder Music Co., 18 East Market street, Wilkes-Barre, Pa., attracted much attention dur-



The Snyder Music Co.'s Unique Float ing the parade in connection with the State Firemen's Convention, held in that city recently, by entering an automobile float, upon which was

mounted an enormous bass drum with two black-face drummers to keep it in action. The drum was inscribed with the name of the company, its address and the fact that it handles pianos, while on the float appeared the words "Columbia Grafonolas." The accompanying illustration gives some idea of the effectiveness of the display.

TO VISIT ENGLAND AND FRANCE

Ross L. Douglass, of the National Co., to Analyze Conditions in These Countries

BOSTON, MASS., November 1.—Ross L. Douglass, chief executive of the National Co., manufacturer of Shimandy, Ragtime Rastus, Boxing Darkies and other talking machine toys, will sail during the early part of the year for England and France. In addition to his own interests, Mr. Douglass plans to represent other manufacturers in this foreign field, with which he is quite familiar through previous trips. The demand for the various talking machine toys made by the National Co. is reported to be rather strong and indications are that this demand will continue for some time to come.



OUR PLANT

CAN BE



YOUR



RECORD PRESSING DEPARTMENT



We take pride in giving every attention to producing perfect records for our customers.

Samples and Prices on request

THE BRIDGEPORT DIE and MACHINE CO.

170 ELM STREET
BRIDGEPORT, CONN.

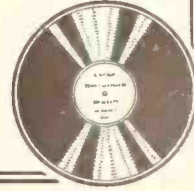

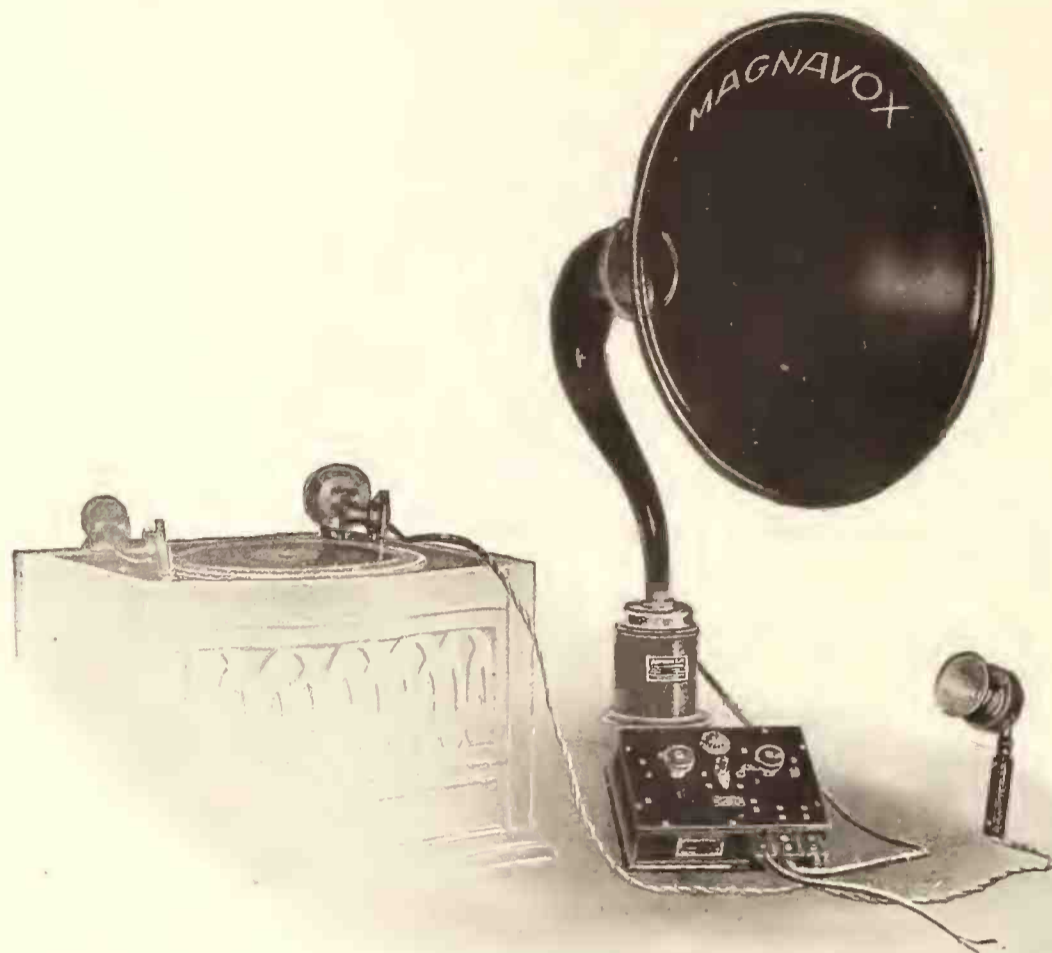

A new source of income for phonograph dealers

PHONOGRAPH dealers are greatly increasing their incomes by selling the Magnavox Telemegafone. Every phonograph owner is a prospect, and the profit realized on each sale makes it worth while.

Every club, school and church should be equipped with a Magnavox, as it is essential wherever entertainments are given. For practically no cost a Magnavox converts a phonograph into a band or an orchestra.

The Magnavox Telemegafone is an electrical device that increases the volume of sound produced by a phonograph to any desired degree. It is durable and thoroughly practical.

Magnavox

Send for **O** Bulletin and full details

The Magnavox Company

General Office and Factory
2701 East Fourteenth Street
OAKLAND, CALIFORNIA

or New York Office
370 Seventh Avenue
Penn Terminal Building
Please address nearest office

Convention of Nebraska Victor Dealers

State Association Holds Fifth Annual Meeting in Omaha on October 17 and 18—Proves a Most Successful Affair in Every Particular—Important and Interesting Business Discussions—Harry S. Thorpe, of Norfolk, Nebraska, Elected President

OMAHA, NEB., November 3.—The fifth annual convention of the Nebraska Victor Dealers' Association, held here on October 17 and 18, proved a really wonderful success and excelled anything ever before attempted along that line. Over 200 dealers were present and without exception were enthusiastic regarding the practical program arranged by Secretary Heyn.

Welcomed by Mayor Dahlman

Monday morning was given over to the registration of dealers, the arrangements being in charge of a reception committee composed of Messrs. Gaston, Robinson, Moores, Walt, Ridnour and Jones. The visitors were formally wel-

comed to Omaha by Mayor James C. Dahlman, after which the delegates devoted themselves to the business of the convention.

Records on Approval," was defended by L. E. Baugh, of Omaha, with Fred Schampp, of Sioux City, on the opposite side. After a heated debate it was generally agreed that the record approval plan, if worked upon restricted lines, can be made very advantageous in building up a substantial record business.

ultimate buyer. No product is fully sold until it finally reaches the hands of the public. There has never been a company that has striven with more conscientiousness to bring about such results than the Victor Co. and of this I am thoroughly convinced since my return to them. Honest goods, made of honest materials, manufactured under conditions as nearly ideal as possible, without regard to cost, etc., so that, all these things being considered, backed up by a free trade service, such as the Victor Co. gives, we believe we have done our part toward solving your problems.

"In a recent conversation with a distributor



Those Who Attended Annual Convention of Nebraska Victor Dealers' Association in Omaha, October 17-18

comed to Omaha by Mayor James C. Dahlman, after which the delegates devoted themselves to the business of the convention.

Window Trimming Demonstration

One very helpful number, and possibly the outstanding feature of this session, was the window trimming demonstration by E. J. Berg, of the Burgess-Nash Co., of Omaha. Wonderful and pleasing effects were obtained by the clever use of simple backgrounds, together with plush and velvets. In speaking Mr. Berg said: "Don't be afraid to spend a little money on fixing up your window. Most merchants look at money spent on trimming windows as something like an income tax. They realize they have to do it, but do it in just as economical a fashion as possible. Your window always reflects the interior of the store and you can rest assured that a cheap, dirty window is in keeping with the merchant's idea of doing business."

Open Discussion of Timely Topics

The meeting was then thrown open to the discussion of various subjects of vital importance to every dealer in attendance. The first subject,

coln, Neb., then spoke on the subject, "Does It Pay to Repossess Promptly?" "Under certain conditions," said Mr. Holland, "it pays to be a little lenient with your customers in paying their monthly accounts. We always consider first whether there is a possibility of their being brought up to date the following month and whether the customer is working for sufficient salary to permit him to do this."

Frank K. Dolbeer Speaks

Frank K. Dolbeer, the newly appointed head of the traveling department of the Victor Co., was then introduced to the Association. Geo. E. Mickel, whose association with Mr. Dolbeer dates back to the early days of the Victor Co., presented him and welcomed him back to the fold after an absence of several years.

Mr. Dolbeer's talk was very interesting. He said: "The dealer's problems are all important ones with us at all times and we have our factory organization constantly striving to bring about a more friendly relation between the distributor and the factory, between the distributor and the dealer and between the dealer and the

some reference was made to a possible plan for the distributor financing the dealer. This is the wrong idea, as it is my opinion that the dealer should finance his own business. There is no doubt in my mind but what the dealer is able to prepare and compile a financial statement which would permit his going to the bank for financial aid and securing enough funds to carry him over a certain period of the year. The bank is in your town for the express purpose of loaning money, so use your banks to the limit before looking elsewhere for credit.

"Claims are being constantly made regarding the merit of competing lines, and it is always best, so far as possible to understand, to be sufficiently able to convince your customer of the superiority of Victor goods. It is useless to state that the really great artists are obtainable only on Red Seal Victor records, but I don't believe that you can be impressed too strongly with the wonderful opportunity to increase profits by carrying sufficient quantities and pushing the sale of the Red Seal records.

"Just a word in reference to canvassing. Most dealers look upon house-to-house canvassing with disdain. We recently sent to every member of our traveling department a letter entitled 'Carrying the Story to the Dealer.' This letter told of the different results obtained by dealers throughout different parts of the country and I would like to mention a few. I know you have heard something of the famous 'Mickel Victrola Club.' This plan originated with Mickel's and is really little more than a canvassing plan backed up by excellent advertising. The costs in connection with this plan were about \$1,600 and the net business done for the month was almost \$17,000. I would suggest that you get in touch with the Mickel organization and learn something of this plan. One of our dealers, located in one of the larger mid-West cities, put on a two weeks' campaign. The result was that 136 Victrolas were sold during that period, making the total business \$18,790.

"One of the most surprising things upon re-

(Continued on page 60)



Let One Man Deliver Your Talking Machine

The Lea Talking Machine Truck will handle the large machine with ease and safety. No stairs too steep. Quickly adjusted to any size or make of machine. Equipped with rubber-tired wheels. The saving of the second man on the wagon will soon pay for the truck.

Write for Circular and Prices

Also

Piano Trucks, Hoists, Covers and Straps

Made only by

Self Lifting Piano Truck Co.

FINDLAY, OHIO

CONVENTION OF NEBRASKA VICTOR DEALERS—(Continued from page 59)

turning to the Victor Co. was to find every department in that tremendous organization working full time, turning out all the goods that were possible and making every effort to fully take care of the business which is sure to come during the holiday season. We are working between 9,500 and 9,600 people and are constantly taking on as many good workmen as we can find."

See Taylor Holmes in "Smooth as Silk"

The meeting then adjourned and after dinner the Association was entertained by the Nebraska Distributors at the Brandeis Theatre, to witness a performance of Taylor Holmes in "Smooth as Silk." Mr. Holmes, being a Victor artist, responded to numerous curtain calls and obliged by reciting two selections which have been recorded, "Boots" and "If I Could Be By Her."

The Tuesday Session

The Tuesday morning session opened promptly at 9 o'clock. On account of illness President Zitzman was unable to be present and Vice-president Thorpe filled the chair. Questions pertaining to the merchandising of Victor goods which had been sent in by various dealers were then assigned to different members to be answered. These questions were quite timely and brought out some very important points. One question, "When are the prices of Victrolas to be reduced?" required the combined efforts of Mr. Dolbeer, Mr. Mickel and a number of dealers. In speaking Mr. Mickel said: "I recall a conversation I had with Ralph Freeman in July, at which time he led me to believe that until manufacturing costs could be reduced the prices to wholesalers would remain as they were. You must admit that the Victor line did not increase in price in the same proportion as did other talking machines. The whole line only showed an increase of about 33 1-3 per cent, of which 5 per cent was a tax by the Government. The Victor Co. employs only the highest-class craftsmen in the manufacture of its product and the salaries of these men have not been reduced."

Other questions pertaining to timely record releases, selling records to the children, business with the farmer, were effectively answered by officials of the Victor Co. and the distributors' representatives.

An Educational Demonstration

The outstanding feature of this session was the educational demonstration by Miss Mayme A. Jardine, of Mickel Bros. Co. With the assistance of three children, Laurretta Boroff, Samuel Carmell and Lloyd Smith, Miss Jardine demonstrated the function of the Victrola in the musical education of the children. "So many dealers," said Miss Jardine, "fail to see that the Victrola in the school is put to the main use for which it is intended. Unless they are shown the teachers use it solely for marching in and out of class or for entertainment. Where the Victrola is most valuable is in the co-ordination with studies, such as history, spelling, arithmetic and in physical education." Laurretta Boroff and

Lloyd Smith danced a number of folk dances, sang and demonstrated the physical education exercises with the Victrola. Each number was done with a change of costume and met with the hearty approval of the members. Samuel Carmell, whose education has been mostly with the Victrola, played the violin with Heifetz, Kreisler and other artists and at no time was it possible to distinguish between the artist and the child. Even the fluctuations of tone were minutely imitated, giving proof that Master Carmell's training with the Victrola promised for him a very hopeful career.

Election of Officers

At the suggestion of the nominating committee the following officers for the ensuing year



George E. Mickel and Frank K. Dolbeer were elected: President, Harry S. Thorpe, Norfolk, Neb.; vice-president, E. H. Ridnaur, McCook, Neb.; secretary, H. G. Heyn, Omaha, Neb., and treasurer, Jos. Pavlik, Omaha, Neb. Executive committee: Fred Schamp, Sioux City, Iowa; Wm. Zitzman, Omaha, Neb.; Paul S. Albright, David City, Neb.; Ed. J. Walt, Lincoln, Neb.; C. A. Moores, Omaha; Ivan Benedict, Clarinda, Iowa, and J. E. Gaskill, Nebraska City, Neb.

The Association was entertained at luncheon by the Nebraska distributors, after which the official photograph was taken.

Jas. J. Davin's Practical Talk

The afternoon session was opened with a



President Thorpe and Secretary Heyn talk by Jas. J. Davin, of Reincke-Ellis Co., Chicago, on the subject, "Questions Victor Dealers Ask Reincke-Ellis." Mr. Davin's talk was exceedingly interesting and the note-books were in evidence in taking down some of the helpful sales suggestions which were given. "So many dealers ask us how much they can afford to

spend for advertising," said Mr. Davin. "Or what percentage of my sales can I appropriate and then upon what shall I decide to spend it? We believe that 4 per cent of a dealer's gross business is a fair proportion. For example, if you are doing a gross business of \$100,000, then \$4,000 would be a fair proportion to spend for advertising. As to the different mediums, consider the direct letter, show windows, newspaper advertising and bill posters. In the larger towns we suggest co-operative advertising. As to the different percentages for each medium you will have to figure that out yourselves, depending upon the possibilities in your community, so take advantage of it. They are high-class cuts and can be used very effectively by every dealer. Keep your mailing lists up. When a customer comes into your store be sure to get his name and address before he leaves. This is more important than selling an 85-cent record, because in getting his name you cinch that customer and make him a friend of the house, and by our friends we prosper. If you don't do it then your competitor is going to do it. I believe a very effective idea is the coupon in connection with your newspaper advertising. This gives you the name of an interested party and permits you to concentrate upon the people who have signified their intention of buying a Victrola. Another good prospect builder is the music census. I know of a great number of dealers who have worked this idea and in each instance has it more than paid any possible expense which might have been incurred in connection with it."

Thurlow Lieurance and Wife Entertain

Prof. Lieurance, the eminent student of Indian song lore, together with his talented wife, then entertained the members. Their offering consisted of their original songs, together with the explanation of the stories which prompted the writings. Mrs. Lieurance sang each number in a different Indian costume and was assisted by Prof. Geo. B. Tack on the flute. Prof. Lieurance had just returned from a two weeks' trip among the Indians in Minnesota, during which time he composed a very pretty ballad, under the title "The Whistling Mallard Fly." As an encore Mrs. Lieurance sang this number and immediately dedicated it to the Nebraska Victor Dealers' Association.

Prof. Condra's Agricultural Survey

Prof. Condra, or as he insists upon being known, "George Condra," delivered an agricultural survey upon the State of Nebraska, showing the dealer how his business is always affected by the conditions of the country. The talk was demonstrated with a stereopticon lantern and the views were of intense beauty. The meeting was then adjourned to meet again at the option of the executive committee.

The Annual Banquet

During the evening the members were entertained at the Hotel Fontenelle by the Nebraska distributors. A sumptuous repast was served and with the assistance of the "Angel Chorus" a very pleasant evening ensued. During the eve-

MASTER WAX

BUSINESS BLANKS

Special Waxes for Recording and Black Diamond Business Blanks

Due to our increased business, we announce that we have moved from 57-59 Paris St., Newark, N. J., to a new and larger factory at 165-167 Bloomfield Ave., Bloomfield, N. J., where we are equipped to produce at a maximum.

We would be glad to discuss a sales proposition from different territories for our output.

The Wax and Novelty Company

165-167 Bloomfield Avenue, Bloomfield, N. J.

F. W. MATTHEWS

CONVENTION OF NEBRASKA VICTOR DEALERS—(Continued from page 60)

ning a number of features were presented. Taylor Holmes obliged with several selections, which aroused the risibilities of those present. Arthur Swanson delivered a Swedish dialect story in costume which was very entertaining. The Benson Orchestra, under the direction of Ralph Williams, played several numbers, some of which had already been released by the Victor Co. and some which are to be released at a later date. Mrs. Lieurance rendered several original compositions which greatly pleased. At a late hour the meeting disbanded after the musicians had played the good-night "Home, Sweet Home."

"Who's Who" at the Convention

Those in attendance were: Audubon Music Co., Audubon, Ia., J. J. Ruhs; Paul J. Albright, David City, Neb., Mr. and Mrs. P. J. Albright; Benedict Piano Co., Clarinda, Ia., I. G. Benedict, W. Benedict, K. R. Sherman; Burgess-Nash Co., Omaha, Neb., Mr. and Mrs. E. M. Francis, Mr. and Mrs. E. J. Berg; Berndt Co., Minden, Neb., August Berndt; Louis Bellaire, La Mars, Iowa, Louis Bellaire; Beard Music Co., Beatrice, Neb., J. W. Beard; Brittell Bros., Harvard, Neb., Mr. and Mrs. H. G. Brittell; Baker's Pharmacy, Havelock, Neb., W. A. Baker, Mr. and Mrs. H. W. Baker; Chapman Furniture Co., Aurora, Neb., Glen Chapman; Daxon Implement Co., Neligh, Neb., Helen Daxon; Dudley Music Co., Fremont, Neb., Mr. and Mrs. C. L. Dudley, Ben McHenry; Davidson Bros. Co., Sioux City, Iowa, Fred Schamp; French Furniture Co., Columbus, Neb., Mr. and Mrs. C. D. French, Ed. Branigan; P. W. Folsom, Ashland, Neb., Mr. and Mrs. P. W. Folsom; Gaston Music Co., Grand Island, Neb., Ed. A. Jones; J. F. Gerke, Stewart, Neb., Rudolph Gerke; Gaskill Music Co., Nebraska City, Neb., Mr. and Mrs. J. E. Gaskill, R. P. Beard; Hardy Furniture Co., Lincoln, Neb., Mr. and Mrs. K. H. Kulp, E. C. Hardy, K. Guy Hunt, Mae Nevitt, Gertrude Mayhugh; A. H. Hlava, Ravenna, Neb., A. V. Hlava; A. Hosper Co., Omaha, Neb., Wm. A. Zitzman, L. E.

Raugh; A. Hosperco, Council Bluffs, Ia., Verna Jones; Holley Music Co., Carroll, Ia., Katherine Tobin, Miss Egan; Huse Pub. Co., Norfolk, Neb., Mr. and Mrs. H. S. Thorpe, Muriel Thorpe; Herrington Drug Co., Newman Grove, Neb., Mr. and Mrs. N. W. Herrington, W. H. English, Jas. Herrington, Eleanor Herrington; Hughes Music Co., Storm Lake, Iowa, Alise Hughes, Katheryn Hughes; Robert L. Harvey, Missouri Valley, Ia., Mr. and Mrs. R. W. Harvey; Hetzel Co., Harlan, Iowa, Mr. and Mrs. Roy B. Hetzel; M. L. Jones, Fairfield, Neb., M. L. Jones; Jones Book & Music Store, Wayne, Neb., F. H. Jones, F. C. Jones; Wm. Kovar, Howells, Neb., Mr. and Mrs. Wm. Kovar; Koutsky-Pavlik Co., Omaha, Neb., Jos. J. Pavlik; Lindholm Furniture Co., Sioux City, Iowa, M. C. Case; Sol Lewis, Omaha, Neb., Sol Lewis; Harry Martin, Lyons, Neb., Harry Martin; Meyers Bros., Villisca, Iowa, Mr. and Mrs. J. T. Meyers; Orchard & Wilhelm Co., Omaha, Mr. and Mrs. J. E. Laycock, Mr. and Mrs. W. G. Brandt, Ed. Schuett, Chas. J. Bell, Nellie Green; Patton Music Co., Omaha, Mr. and Mrs. Ed. Patton, Austin Topping, W. R. Thomas, H. H. Rohrs, Robt. Nichlen, D. V. Capron; F. G. Palmquist, Oakland, Neb., F. G. Palmquist; Ruzika's Pharmacy, Lindsay, Neb., L. C. Ruzika; Russell Music Store, Logan, Ia., Mr. and Mrs. Ed. Russell, Lilla Case; Ridnour Piano Co., McCook, Neb., E. G. Ridnour, Miss Ridnour; Roberts Music Co., North Platte, Neb., J. R. Roberts; G. R. Ray, Osceola, Neb., G. T. Ray; Tout Drug Co., York, Neb., D. R. Salisbury; Trafford Co., Mason City, Iowa, L. Earl Elsham; Schultz & Son, Stanton, Neb., F. H. Schultz, M. S. Hanel; H. R. Stanzel, Odebolt, Iowa, Mr. and Mrs. H. R. Stanzel; Walt Music Co., Lincoln, Neb., H. G. Barth; White Music Co., Fairbury, Neb., Mr. and Mrs. Geo. W. White; Wickman Pharmacy, Ord, Neb., R. F. Wickman; Algona Music House, Algona, Iowa, John Mesing; A. L. Cummings & Co., Sheridan, Wyo., Mr. and Mrs. Nick Nelson; Elgin

Drug Co., Elgin, Neb., Dr. W. A. Peterson; Fannan Music Co., Tecumseh, Neb., Mr. and Mrs. W. R. Fannan; Swan Furn. Co., Auburn, Neb., Mr. and Mrs. R. R. Swan, Mr. and Mrs. O. A. Corey, Mrs. M. Brodner, Mildred Newman; Mickel Music Store, Council Bluffs, Iowa, Mr. and Mrs. A. L. Mickel, Mrs. M. King, Marie Mahoney, Mrs. Seifert, Mr. and Mrs. C. A. Bengston; Mickel Music House, Omaha, Neb., Mr. and Mrs. E. H. Pretz, Mr. and Mrs. T. E. Mickel, Grace Mickel, Harold Anderson, Bess Greenberg, Mrs. C. C. Beams, Pearl Kelsey, Pearl Beach, Jeannette Louiacouer; Ross P. Curtice Co., Lincoln, Neb., Ross Curtice, Mr. and Mrs. W. Brewster, Mr. and Mrs. W. E. Kincaid, Mr. and Mrs. S. B. Yule, W. A. Howland; Ross P. Curtice Co., Omaha, Neb., Ross Curtice, Norman Curtice, Mr. and Mrs. C. R. Moores, Mr. and Mrs. Phil Haney, Gertrude C. Thompson, M. E. Tinchinor, Florence Gaughan, Nellie Deal, Louis E. Gaillan, Mr. and Mrs. W. A. Wolf; Mickel Bros. Co., Omaha, Neb., Mr. and Mrs. G. E. Mickel, Mr. and Mrs. E. Probst, Hugo G. Heyn, E. W. Lundquist, Honor Yard, Agnes Slaven, Loucile Ellis, Grace B. Cozzens, Lillian Polk, Mr. and Mrs. E. N. Bowerman, Mr. and Mrs. J. H. Ready, Mr. and Mrs. H. B. Sixsmith, Mayme A. Jardine; Victor Talking Machine Co., Camden, N. J., Frank L. Dolbeer, G. L. Richardson; guests—J. J. Davin, Chicago; Mayor Jas. C. Dahlman, Omaha; Dr. G. E. Condra, Mr. and Mrs. Thurlow Lieurance, Lauretta Boroff and Samuel Carmell, Lloyd Forrest Smith, Geo. B. Tack, Taylor Holmes, Arthur Swanson, A. M. Newens.

Dealers become better merchandisers when they really become enthusiastic over the wonderful possibilities of the talking machine and the marvelous records which do so much to spread musical knowledge and appreciation.

It is well for salesmen to cultivate a smile during their period of service in the store.

Sherman, Clay & Co.

Pacific Coast Distributors



Victor Victrolas Victor Records Victor Accessories

Main Wholesale Depot:

741 Mission Street, San Francisco

Branch Wholesale Depots:

444 So. Broadway, Los Angeles, California

45 Fourth St., Portland, Oregon

Oceanic Bldg., Cor. University and Post Sts.,

Seattle, Washington

427 West First Ave., Spokane, Washington

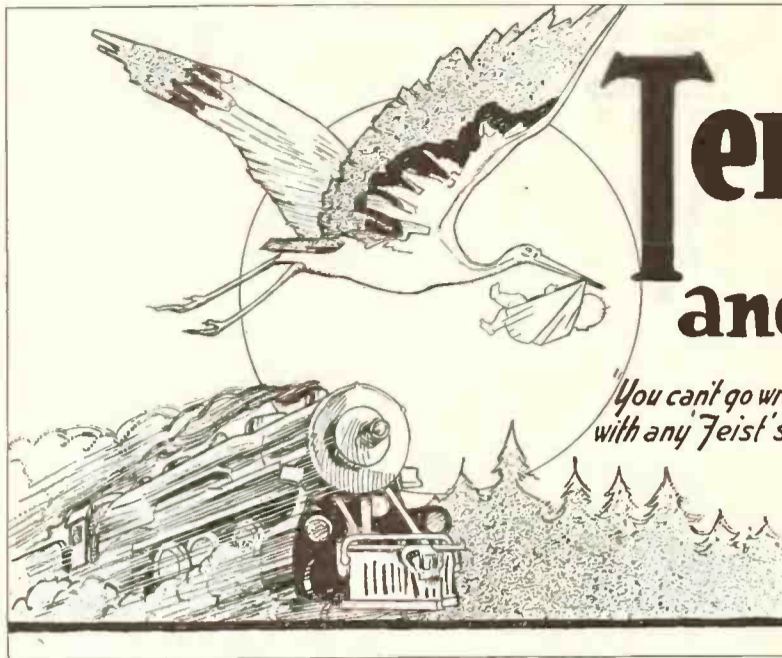

Ten Little Fingers and Ten Little Toes

*"You can't go wrong
with any Feist song"* **A "Peach" of a song!**

ASK TO HEAR IT!

G. W. HOPKINS A DIRECTOR

Vice-president of Columbia Co. Elected to Directorate of That Concern

At the annual meeting of the stockholders of the Columbia Graphophone Co., held recently at



George W. Hopkins

the company's executive offices in New York City, George W. Hopkins, vice-president and general sales manager of the company, was elected a director of the company. An an-

nouncement to this effect was made to the Columbia organization at that time and brought telegraphic congratulations from Coast to Coast. Mr. Hopkins, who joined the Columbia organization a few years ago as general sales manager, was elected vice-president of the company last month, in recognition of his indefatigable efforts in behalf of Columbia interests. His election as a director will be welcome news to his legion of friends in the industrial and publicity worlds.

W. H. ALFRING HOME FROM COAST

Manager of Wholesale Department of Aeolian Co. Finds Business Generally Improving

W. H. Alfring, manager of the wholesale department of the Aeolian Co., returned recently from a transcontinental trip, in the course of which he called upon the leading Aeolian Co. representatives in a number of the principal cities. Mr. Alfring had originally planned to go only as far as Denver and perhaps Salt Lake City, but his trip was finally extended to take in San Francisco, Los Angeles and other Coast cities.

In practically every section of the country visited Mr. Alfring found distinct evidences of improved conditions, particularly as they concern the sale of musical instruments, and the various lines featured by the Aeolian Co., including Duo-Art pianos and Vocalion phonographs and records, were reported to be in increasing demand everywhere.

MEETING OF TALKING MACHINE MEN

Local Dealers' Organization Enjoys Demonstration of New Berlin Songs and Listens to Talk on Sheet Music Merchandising—Plans for Ball on November 17 Are Announced

The monthly meeting of the Talking Machine Men, Inc., was held on Monday afternoon, October 24, at the Café Boulevard, New York City, the meeting proper being preceded, as has been the usual custom in recent months, by a luncheon.

It was known as "Irving Berlin Day" and several members of Irving Berlin, Inc., the music publisher, including Irving Berlin himself, were on hand. Ed Christie, manager of the mechanical reproduction department of the Berlin house, made an address in which he outlined the proposed activities of the various departments of the concern during the coming months. Phil Davis rendered several of the latest Berlin successes, assisted by L. Johnston at the piano. These included: "Birds of a Feather," "Tuck Me to Sleep" and "Say It With Music."

Upon the arrival of Irving Berlin, who was accompanied by Saul H. Bornstein, of this company, a rousing reception was tendered him by those assembled.

It was announced that Branson DeCou would give an exhibition of his "Dream Pictures" at the next meeting of the Association, which will be held on November 16. Also at that time the Broadway Music Corp., under the personal direction of Will Von Tilzer, president of the company, will demonstrate several songs from the Broadway catalog.

In honor of the late Isaac Davega the gathering stood silent for one minute, following which the secretary was instructed to draw up a resolution expressing the Association's regret at his loss, which is to be forwarded to Mrs. Davega.

S. Kronberg, of the Plaza Music Co., then addressed the gathering on "How to Merchandise Sheet Music." He stated that it was his opinion that the day of the exclusive record and talking machine shop was past—the success of sheet music in talking machine warerooms had demonstrated that such departments were most feasible and profitable.

He divided the plans for such a department into three divisions—the advantage and benefits, the buying and the selling. These were the important features, he said, and dealers who would give the matter consideration along those lines would find sheet music an important adjunct to their business, from a profit standpoint as well as a sales attraction.

Mr. Kronberg stated that while the use of a piano would obviously be an advantage and a great attraction in the sale of sheet music, yet he believed that these goods could be demonstrated and sold quite successfully without the aid of a piano, for what sheet music needed most was proper display.

Final plans for the coming reception and ball of the Association, to be held at the Hotel Pennsylvania on the evening of November 17, were announced.

Ward's Khaki Moving Covers



Grade "D" Cover with

No. 3 Straps

THE C. E. WARD CO.
(Well-Known Lodge Regalia House)
101 William Street New London, Ohio
Also Manufacturers of Rubberized Covers
and Dust Covers for the Wareroom

Distributors

- BRISTDL & BARBER, INC.
3 E. 14th St., New York City
- YAHR & LANGE DRUG CO.
207-215 E. Water St., Milwaukee, Wis.
- COHEN & HUGHES, INC.
Washington, D. C.
- BECKWITH-D'NEILL CO.
Minneapolis, Minn.
- STREVELL-PATERSDN HARDWARE CO.
Salt Lake City, Utah
- C. L. MARSHALL CO., INC.
Beckman Bldg., Cleveland, O.
Butler Bldg., Detroit, Mich.
- THE REED CO.
237 Fifth Avenue, Pittsburgh, Pa.
- C. J. VAN HDUTON & ZDON
140 S. Dearborn St., Chicago, Ill.
- SONORA DISTRIBUTING CO. OF TEXAS
Dallas, Texas
- KNIGHT-CAMPBELL MUSIC CO.
1608 Wynkoop St., Denver, Colo.
- CHAS. H. YATES
311 Laughlin Bldg., Los Angeles, Cal.
- W. D. & C. N. ANDREWS
Buffalo, N. Y.
- SACHS & CO.
425 So. Wabash Ave., Chicago
- SHERMAN, CLAY & CO.
741 Mission St., San Francisco, Cal.
- JOHN A. FUTCH CO.
35 Auburn Ave., Atlanta, Georgia
1500 South Boulevard, Charlotte, N. C.
630 Washington St., Jacksonville, Fla.
- ORTON BROTHERS MUSIC HOUSE
Butte, Mont.
- GRAY & DUDLEY CO., Nashville, Tenn.
- ASSOCIATED FURNITURE MFRS.
St. Louis, Mo.
- W. J. DYER & BRO., St. Paul, Minn.
- AMERICAN PHONOGRAPH CO.
Burlington, Vt.
- JOSEPH BARNETT & CO., Cedar Rapids, Ia.



THE
MOST MODERN
OF
PHONOGRAPHS

*The
Very Spirit of the Holidays*
lives in this
Wonderful
Phonograph

It Is an Ideal Instrument

Stately and Dignified in appearance and Entirely Different. Round in form, substantially built and beautifully finished. Surmounted by a handsome stand lamp that sheds a soft, cheerful glow that adds to the pleasure of enjoying the flawless tone quality.

Spacious record filing compartment. Made up in variety of woods and finishes and a wide selection of lamp shades. Altogether the newest and most appealing of Phonographs. A business asset for every live Dealer.

Place Your Order Now!

Our new and complete plant is fully equipped to make prompt deliveries. We offer a wonderful and timely Holiday Opportunity. For full information address Department D.

Our Eastern Sales Representatives

We have appointed the Modernola Sales Co., Inc., with offices at 927 Broadway, New York City. They are sales representatives for Greater New York, Eastern New York State, Connecticut, Rhode Island, Northern New Jersey.

Phone, Ashland 7453

Warehouse, 101 W. 20th St.



THE MODERNOLA CO. JOHNSTOWN, PA.

PRIZE-WINNING EDISON SALESMEN

Prize-winners From Middle West and New England Visit Thos. A. Edison—Entertained at Luncheon—Call on President Harding

There has been a prize sales contest on among Edison salesmen, conducted by Edison jobbers. The first two groups to get their reward came from the Middle West and New England. The first group comprised eighteen dealers from Kansas City, Chicago, Detroit and Milwaukee territories. The prize was a trip to Orange and return, with various entertainment features.

At Chicago the Western party was entertained by F. K. Babson at the Chicago Athletic Club. The itinerary from Chicago to Orange included a boat ride on Lake Erie, a visit to Niagara Falls and a daylight trip down the Hudson to New York. In the big metropolis the excursion visit-

ETCHED METAL NAME-PLATES

FOR MANUFACTURERS AND DEALERS



Write for prices stating quantity desired



EVERLASTING

NEAT IN APPEARANCE

ELECTRO-CHEMICAL ENGRAVING CO., Inc., 52 Vanderbilt Avenue, New York, N. Y.

Several of the officials of the Edison Co., including Charles Edison, Mr. Maxwell and Mr. Curry, also the departmental heads of the musical phonograph division, attended the luncheon and addressed the prize-winners. Following the

companying the prize-winners throughout the trip were: M. M. Blackman, Kansas City jobber, and H. A. Bailey, his sales promotion manager; R. B. Alling, Detroit jobber, and W. C. Eckhardt, sales promotion manager at Chicago.

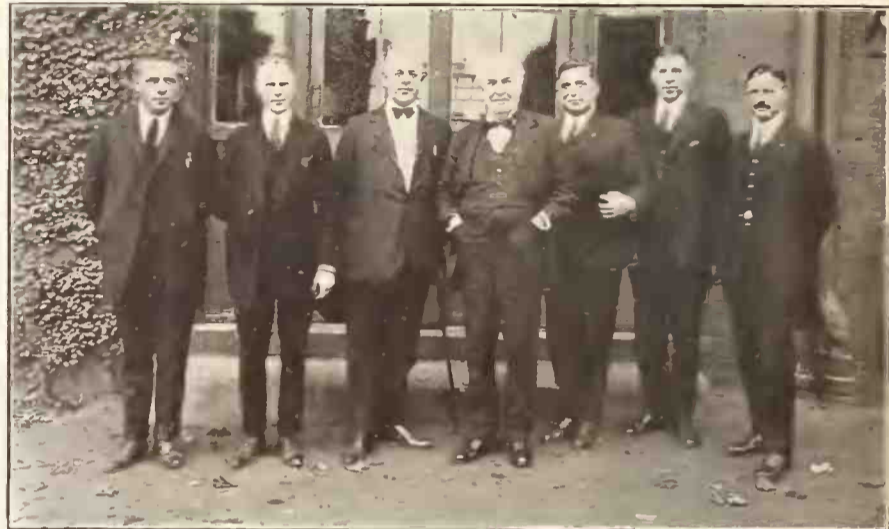

The Western Group of Prize-winning Salesmen With Mr. Edison

The New England Group of Prize-winning Salesmen With Mr. Edison

ed the most prominent places of interest, and, before coming to Orange, recorded their voices on a souvenir Re-creation at the recording studios on Fifth avenue.

At Orange the visitors were entertained with a luncheon at the celebrated Mushroom Farm.

luncheon the visitors were presented to Mr. Edison and made a trip through the laboratories.

The party returned to their respective territories via Washington, where they had an audience with President Harding, arranged through the courtesy of Senator Capper, of Kansas. Ac-

The other group, hailing from New England, and representing the Pardee-Ellenberger Co., Inc., at Boston, Mass., and New Haven, Conn., had a similar program as that enjoyed by their Western brothers. Each salesman received from Mr. Edison his autographed photograph.

OKeh Records

offer the advantage of unlimited sales.

The collector of beautiful opera arias is perfectly satisfied with OKeh Opera Records.

The dancers say, "They find all the real joy of dance music on OKeh Dance Records."

The stay-at-home says, "OKeh Records make home worth while."

We Say,

"An OKeh Agency Is Yours for the Asking."

OKeh Records

OKeh Records

KENNEDY-SCHULTZ COMPANY

1865 PROSPECT AVE.

CLEVELAND, OHIO



ANTICIPATE

Your Orders for

LONG

Console Cabinets

The tide has turned, and the LONG factory is now working overtime to cope with the demand for LONG CONSOLE CABINETS.

Avoid disappointment and anticipate your orders as far ahead as possible. This is not an idle prediction, but a suggestion based on actual facts. We are receiving orders by telegraph, telephone and mail, and we are endeavoring to give our dealers prompt and efficient service.

LONG CONSOLE CABINETS are the pioneers in this field. They have won countrywide success through superb quality and unsurpassed workmanship, and they will bring profits and prestige to your establishment.

Place your orders today.

**The Geo. A. Long
Cabinet Company**
HANOVER, PA.



Style 600
Sheraton



Style 601
Colonial



Style 602
Louis XV



Style 603
Chippendale



Style 604
Hepplewhite

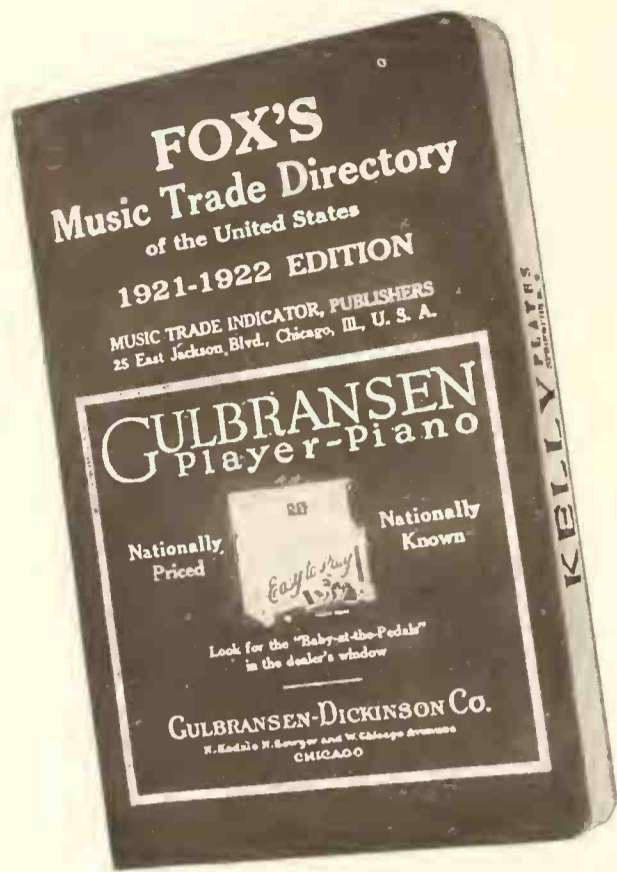

"The Original Music Trade Directory"

\$1.00 Per Copy

For Your Mailing Lists

Fox's Music Trade Directory (“The Red Book”)

Contains the most complete lists ever compiled in the music industry, including:

Phonograph Manufacturers
Phonograph Record Manufacturers
Phonograph Supply Concerns

Piano Manufacturers
Piano Retail Merchants
Piano Supply Concerns

Also lists of sheet music publishers, small goods and organ manufacturers.

MUSIC TRADE INDICATOR

Publishers
25 E. Jackson Blvd. Chicago

TRADE IN NEW ORLEANS SHOWS DECIDED IMPROVEMENT

Dealers Make Splendid Showing in Way of Sales—Advertising Under Way—Edison Trade Expands—Free Service Bureau at Maison Blanche—Guenard and Blache Open New Stores

NEW ORLEANS, LA., November 4.—The talking machine trade in this vicinity is declared to be on the boom and the increase is noticeable wherever one turns. This business improvement is credited largely to the efforts of one of the liveliest aggregations of sales managers and salesmen in the country.

More space in the daily papers is being devoted to advertisements of musical instruments and accessories, many schools are adding talking machines to their equipment, business offices are buying outfits to increase the efficiency of employes, and even the bootblack parlors are buying talking machines to attract trade.

Joseph L. Billeit, manager of the Diamond Disc Co., Edison jobber, declares that during the past year business has improved 53 per cent and that 25 per cent of the increase is due directly to the effect of mood parties advertised by the company and held under its auspices.

A new department, to be known as the “Sales Aid Service Department,” has been added by the Diamond Disc Co. The staff of the new department will undertake to look after the machines

of Edison owners and keep them in repair. The plan calls for regular visits to Edison owners by a crew of five men, who on each visit will carry some of the latest records for demonstration purposes.

The Edison Shop on Barrone street is also reporting good results. Here is being tried out very successfully a selling policy that encourages the visitor to sell himself, as it were. The work of the sales staff consists of making the visitor feel at home and provides a knowledge of the convincing qualities of Edison machines and Re-creations, but no sales talk as such is indulged in.

An Edison machine was recently installed in the Delgado Trade School, a new school just opened for vocational work. It was selected by the vote of the students.

The L. Grunewald Co., Ltd., got some good publicity for the Grafonola during the period of the World Series. The company arranged for the installation of a Grafonola where the baseball returns were received and the music entertained the crowds before and during the game.

The music department of the Maison Blanche has established a free service bureau for the benefit of the company's customers, and it is found that the plan is working out very satisfactorily.

L. A. Guenard, formerly manager of the Grunewald music store branch on Rampart street, has just gone into business for himself. He has opened two small stores, one at 1509 Dryades street, the other at 109 University Place, just half a block off of Canal street, the main thoroughfare. His stock consists of Victor machines, Victor and Okeh records and Q R S player rolls. Later he intends to extend the business and sell a general line of musical instruments. He has already ordered a few harmonicas and musical accessories. He also repairs talking machines and musical instruments. His partner is Harry Roach.

Up on Barrone and Poydras streets, J. Henry Blache, of the Oraphone, has just opened a small music shop where he handles records and Oraphones, a machine of his own make. His shop is located at 334 Carondelet street. Mr. Blache has been in the music trade for some time, having traveled on the road in the interest of the Oraphone. He knows the trade and states that all indications point to an excellent season in the music trade.

Do You Throw Money Away?

It is not a popular pastime—but still it is unconsciously done by many who just don't know that *Repair Parts* can be bought for less

**RENE MADE SPRINGS AND PARTS ARE BETTER
COST LESS**

RENE MFG. CO.

Montvale, N. J.

VISITORS TO COLUMBIA CO.

Branch Managers From Widely Separated Points Visit New York Headquarters

Among the recent visitors to the Columbia executive offices, New York, were A. B. Creal, manager of the company's New Orleans branch, who brought with him optimistic reports of the business situation in the South. C. F. Schaffarzick, of the Columbia Stores Co., Spokane, Wash., and C. A. Delzell, of the Columbia Stores Co., Denver, Col., spent a few days at the Columbia offices recently, discussing general sales plans with Geo. W. Hopkins, vice-president and general sales manager of the company.

ATLAS PACKING CASES

and

Perfect Package Month—November, 1921

Aid this nation-wide movement for perfect packing by shipping in "Atlas" Plywood Packing Cases. They will effect a tremendous saving in loss from damage alone as well as countless dollars in freight charges.

For years we have been making the perfect container for the shipment of talking machines.

The trade-marked "Atlas" Case is the acknowledged standard of the Talking Machine Industry.

It is far more than a wooden box. It is designed architecturally for one specific purpose—the delivery of talking machines in perfect condition.

We have made it our business to know the needs of the Talking Machine Industry, and the thoroughly co-ordinated quantity production of our four mills insures prompt and sure service.

"Atlas" Plywood Packing Cases make a better appearance, give greater protection and save freight. Their use indicates the high quality of the contents.

Shipments in Carload Lots Only.

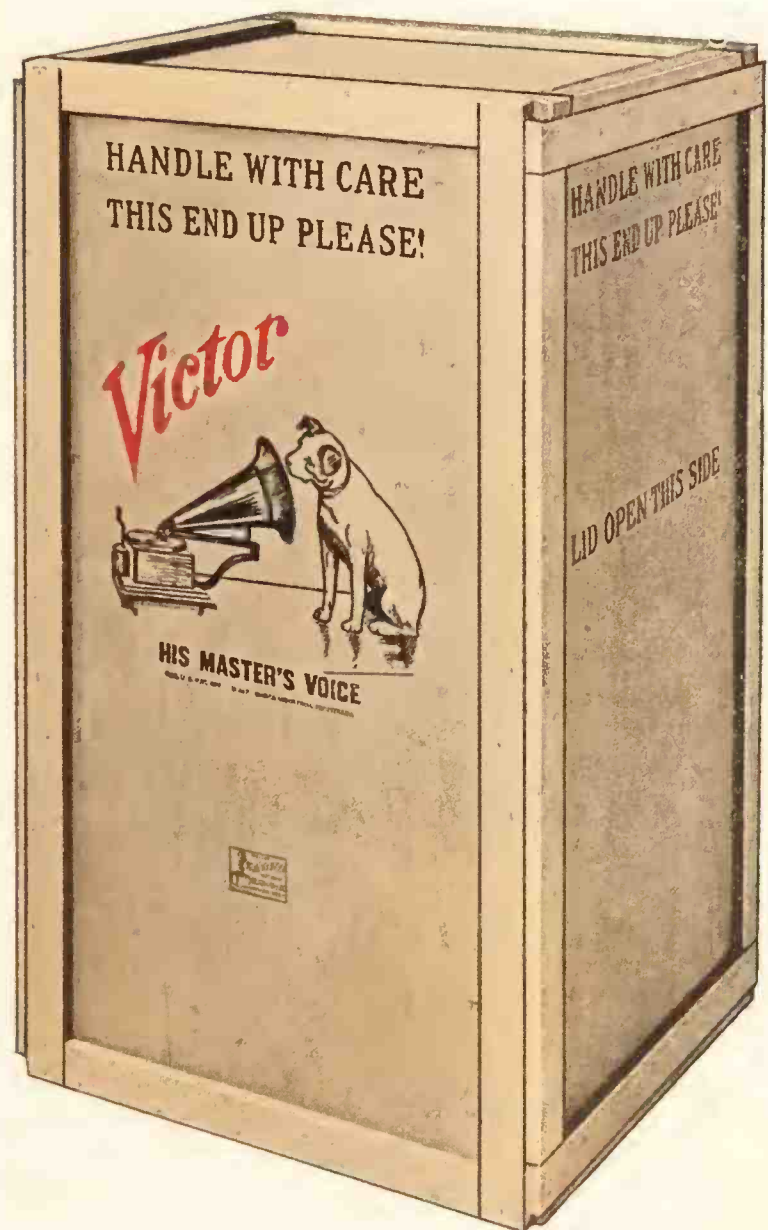

This is an exact reproduction of an "Atlas" Packing Case manufactured, printed and shipped to the Victor Talking Machine Co., Camden, N. J.

ATLAS PLYWOOD CORPORATION

RICHFORD

VERMONT

LARGEST MANUFACTURERS OF TALKING MACHINE PACKING CASES

REPAIRS

TALKING MACHINE TROUBLES AND HOW TO REMEDY THEM

Conducted by Andrew H. Dodin

INFORMATION FOR REPAIRMEN

Morsemere, N. J., October 29, 1921.

A. H. Dodin, Care Talking Machine World:

Your name has been referred to me in my endeavors to get information regarding the repairing of talking machines. It frequently happens that while visiting various homes in connection with my business of tuning and repairing pianos and player-pianos I receive requests to repair talking machines, or am asked if I do such work.

Not being acquainted with the talking machine mechanisms I should like to know if there is any shop or place where I may gain such information. I thank you in advance for any information you may give me.—George P. Kirsten.

Answer. I do not know of any shop where you could learn the business of repairing talking machines at the present time.

The Victor Co. permits any man who is employed by its dealers to go to its factory in Camden, N. J., and take a course in adjusting its machines, and I believe the Edison and Columbia companies do the same, but I do not know whether they extend this privilege to anyone not employed in one of their agents' stores.

I would suggest that you get from various companies the little instruction books that they send to their dealers, and if you make a good study of them and also take a motor and take it apart and study the various parts and their relation to each other in the construction of the motor I am quite sure that it would not be very long before you would be able to handle most of the repairs that would come your way.

I am always ready to give you any assistance that I can and will be pleased to answer any questions which you may wish to send me in reference to any troubles you run across in your repair work.

* * *

Watch Out for Chilled Springs

As it will not be long before cold weather will again be with us, together with the usual busy season for talking machine sales, I believe it is the right time to again caution dealers in the matter of delivering and setting up machines in cold weather to avoid spring breakage and other troubles. It also happens frequently that a machine is delivered on a cold day, set up in the home and then put out of order through the breaking of a spring during the first winding.

As has been pointed out on previous occasions, the talking machine spring is a highly tempered piece of steel and as such is subject more or less to temperature changes. It frequently happens that a new machine is taken from a rather chilly warehouse, kept out in the air on a truck for several hours and then installed in the home where the temperature is at seventy degrees or more. Cold makes all steel brittle, and when the enthusiastic purchaser seeks to play a record at once to try out the new musical instrument the cold and brittle spring refuses to stand the strain and snaps.

A great many dealers realize this condition and warn customers regarding it. One dealer goes so far, in the Winter, as to attach a special tag on the winding key advising the purchaser to let the machine rest in the warm room for twenty-four hours before winding. This rest serves to take the chill out of the spring and prevent its sudden snapping.

Banks, and not depositors, are responsible for losses sustained by depositors upon checks drawn by depositors' agents in excess of the amount fixed by depositors, as a result of the refusal of the United States Supreme Court to review a decision of the Pennsylvania courts to this effect.

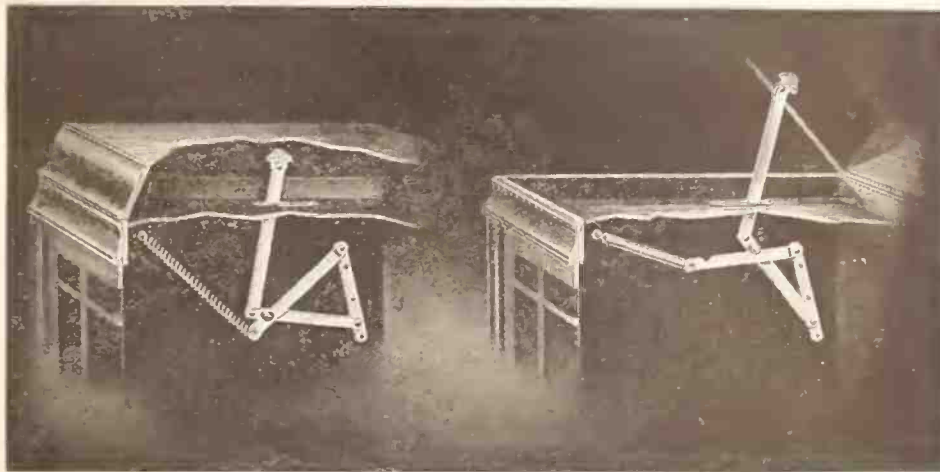

The Superior Lid Support

A touch of one Finger lifts or closes the Lid, which stops at any point desired Does not warp the Lid

Sample Prepaid, \$0.75 Nickel—\$1.25 Gold
Quantity Prices on Application



Superior Specialties for Phonographs
BARNHART BROTHERS & SPINDLER
Monroe and Throop Streets CHICAGO

"BUILT-IN" TALKING MACHINES

Latest Idea of Architects Serves to Arouse Considerable Newspaper Comment

The recent announcement of a New York architect to the effect that he has made provision in some of his new apartment houses for built-in talking machines has aroused considerable comment in newspapers in various sections of the country. The Toledo Blade, for instance, regards the innovation as a natural development in home designing and construction, and says editorially:

"The suggestion made the other day that it would not be long before we should have houses with the talking machine built in can be taken as a prophecy by the thoughtful if they wish. It is not as grotesque as it appears at first glance. Perhaps it will not be the talking machine but something else equally remote as a permanent fixture. The trend of build is that way.

"There are many houses still standing in this city which were erected without provision made for furnaces; hundreds that were built without

thought of electric lights; and it is a smart architect who includes in his plans conduits for telephone wires.

"A bath-tub in a room specially constructed for bathing purposes, with connections to a constant supply of water and means of providing hot water at any time, would have seemed something like a Jules Verne tale not so many generations ago, while the proposition of building an ice-box into a house would have appeared idiotic in the boyhood days of most men of riddle age at present.

"Architecture, taking so many of its ideas from the civilization of the Greeks and Romans, has been slow to join forces with science, but it is doing it now. The theory that the useful cannot be beautiful is vanishing. When we get back the habit of building houses for people to live in we shall see more strange things in the way of 'built-in' innovations than talking machines."

Headquarters for the manufacture of talking machines have been opened at 116 Patton avenue, Asheville, N. C., by William Haverman, who makes both the cabinets and the motors for his machines.



PHONOSTOP

5th Successful Year

ACCURATE—SIMPLE—DURABLE

Reasonable Price

Guaranteed Fully

Nickel or Gold

UNIVERSAL STANDARD



NEED-A-CLIP

New Fibre Needle Clipper

Guaranteed

RETAIL

AT

75 cents

Trade Discount

A SUPERIOR TOOL

THE PHONOMOTOR CO., 121 West Ave., Rochester, N.Y.



Widdicomb console Early American Art model, with divided top, partitions for album, automatic stop and patented tone control. The Widdicomb plays all records. New prices on the various models range from \$95.00 to \$300.00.

The Widdicomb makes a twofold appeal to buyers

Merchants with the Widdicomb franchise are winning increased patronage

IN the pioneer days of the phonograph, little heed was given to beauty of design and cabinet work. In the effort to perfect musical reproduction, appearance was more or less lost sight of.

The Widdicomb Furniture Company were the first to sense the possibilities of a new idea in phonograph construction. Why not combine perfection as a reproducer with artistic design and finish commensurate with the prominence of the phonograph in the home?

For 56 years they have been recognized leaders as fashioners of beautiful furniture. Their exclusive creations in period design set the standard for fine cabinet work. With this broad experience of the popular taste for period furniture, they visualized the appeal of a phonograph of similar master craftsmanship.

Unusual beauty of design attained

From that beginning came the exquisite Widdicomb Period Phono-

graphs of today, distinguished by the same artistic skill and master craftsmanship that have always marked Widdicomb furniture creations. Faithful interpretations of the best designs of the old masters of woodworking, they have an added touch of rare charm and individuality that is distinctively Widdicomb.

Today the Widdicomb has rightfully earned its name—"The Aristocrat of Phonographs." Built in Adam, Queen Anne, Chippendale and other popular period styles, in beautiful red or antique mahogany and walnut, it has won for itself a distinct popularity among people who appreciate true art in furniture.

New tonal perfection achieved

While master designers were producing these exquisite cabinet models, phonograph experts were quietly working to establish tonal supremacy for the Widdicomb. After two years of experimental work they developed the Widdicomb Amplifying Tone Chamber, an exclusive Widdicomb

feature which marks a new era in musical reproduction.

This chamber, built of a patented composition, extends and expands the sound waves as they pass through, giving a full, rich and clear reproduction of every note in the chromatic scale. The deep, rich notes of an orchestral selection are reproduced, by the Widdicomb, in their proper relationship with the notes of the higher register. All metallic harshness, all suggestion of "blasting," is entirely eliminated.

To dealers who are interested in laying a strong foundation for increased patronage, and for broadening their sales opportunities, we have an excellent proposition to offer. Write today for full particulars concerning the Widdicomb franchise, and for complete catalog of the various Widdicomb styles and models.

The Widdicomb Furniture Company

Grand Rapids, Michigan

Fine furniture designers since 1865

All Widdicomb models are now selling at pre-war prices.

Widdicomb
PHONOGRAPH
The Aristocrat of Phonographs

A FEW WORTH-WHILE SALES IDEAS

Timely Sales Suggestions Which Will Bring Profit to the Dealer—Methods for Increasing Sales of Talking Machines During Holidays

Some very timely and worth-while sales suggestions are contained in a recent issue of *The Advance*, published by the Putnam-Page Co., Victor distributor, Peoria, Ill., as follows:

"Include in your record selection sent with your machine sale several records for children.

"Use your telephone two hours each day to call attention to your record stock—your ability to fill orders, or that record orders are not forgotten, etc. Customers appreciate such service. Your sales will be increased—your shop and its service brought to the minds of people.

"To review the program of Victor artists before the concert means more interest, greater appreciation—hence bigger sales. After the concert keep the thought and attention centered on good music and music you have to sell.

"Give Elman, Galli-Curci, Kreisler and McCormack concerts—in fact, the records of all Red Seal artists will make a program which will be appreciated and enjoyed by everyone. Be careful that your program is arranged as it should be. Explain briefly interesting facts concerning the records and music—the artist—the opera, etc. Attract music-lovers to your shop—help make all lovers of good music.

"Make your Christmas plans early! An attractive box with six records or an album with six or twelve records will make a gift all will appreciate. Have cards ready for customers to enclose and necessary material for wrapping so that the gift idea and giving Victor records are one and the same thought. A Victrola sold at Christmas means a new library of records the early months of the new year.

"Thanksgiving offers also an avenue to increase sales. All records make suitable gifts and there are many featuring the harvest season. Your window, your advertising and record suggestions arouse interest in this holiday. The

public is glad to have and deserves this information and you will be repaid by renewed interest in your product, which is sure to mean greater demand and real sales."

OUR TALKING MACHINE EXPORTS

Exports, Including Records, for Nine Months Ending September, 1921, Total \$934,366

WASHINGTON, D. C., November 5.—In the summary of exports and imports of the commerce of the United States for the month of September, 1921 (the latest period for which it has been compiled), which has just been issued, the following figures on talking machines and records are presented:

The dutiable imports of talking machines and parts during September, 1921, amounted in value to \$41,729, as compared with \$65,776 worth which were imported during the same month of 1920. The nine months' total ending September, 1921, showed importations valued at \$462,752, as compared with \$673,973 worth of talking machines and parts during the same period of 1920.

Talking machines to the number of 1,977, valued at \$91,893, were exported in September, 1921, as compared with 8,690 talking machines, valued at \$308,401 sent abroad in the same period of 1920. The nine months' total showed that we exported 26,974 talking machines, valued at \$1,287,683, as against 59,895 talking machines, valued at \$2,815,834 in 1920, and 45,223 talking machines, valued at \$1,554,445, in 1919.

The total exports of records and supplies for September, 1921, were valued at \$137,962, as compared with \$262,252 in September, 1920. For the nine months ending September, 1921, records and accessories were exported valued at \$1,646,683; in 1920, \$2,836,696, and in 1919, \$2,530,599.

Burns & Moreland, music dealers, of Kansas City, Mo., will soon open a Columbia shop in Cameron, Mo.

BUBBLE BOOKS TO BE FEATURED

Bubble Books Will Be Included in Special Campaign Launched by Book Association—Travelers Report Increased Activity Everywhere

The Bubble Book division of Harper & Bros., New York, reports that sales for the month of October more than doubled the sales of the previous month, and General Manager Foster believes that this is an indication that the coming months will be generally prosperous for the talking machine dealer. Dealers who carry Bubble Books are making extensive plans to link up their activities with the nation-wide campaign which the children's book committee of the National Book Publishers' Association has inaugurated for the week commencing November 13 and ending November 19.

A feature of this campaign will be a series of lectures to be given in the leading cities by well-known authors of children's books, among whom are David Corey and Margaret Gerry Spaulding. As Bubble Books are designed for children, they will be included in this intensive campaign. Timely and attractive advertising material prepared by Harper & Bros. has been forwarded to the dealers featuring Bubble Books.

J. B. Price, Middle West representative for Bubble Books, who has just returned from a successful trip, reports that talking machine dealers are unusually active and that Bubble Books are being featured in the largest stores in Middle Western cities. The Chubb-Sternberg Music Shop, of Cincinnati, O., recently devoted its entire front windows to an attractive display of Bubble Books, which was given special editorial mention by all the local papers because of its originality and attractiveness.

Lee Conover, who covers New England and New York State, is now visiting the trade up-State, and states that dealers in his territory are enthusiastic over the way Fall business is opening up, and are confident that sales this Winter will show a decided increase over last year.

The Selling Power of Flexlume Signs

Here are some of the things which give Flexlume Electric Signs their selling power:

They have maximum advertising display.

They are day signs as well as night signs—raised, snow-white glass letters on a dark background.

They have greatest reading distance, lowest up-keep cost, most artistic designs.

Let us send you a sketch showing a Flexlume to meet YOUR particular needs.

FLEXLUME SIGN COMPANY

36 KAIL STREET

BUFFALO, N. Y.

Flexlume Electric Signs Made Only by The Flexlume Sign Co.



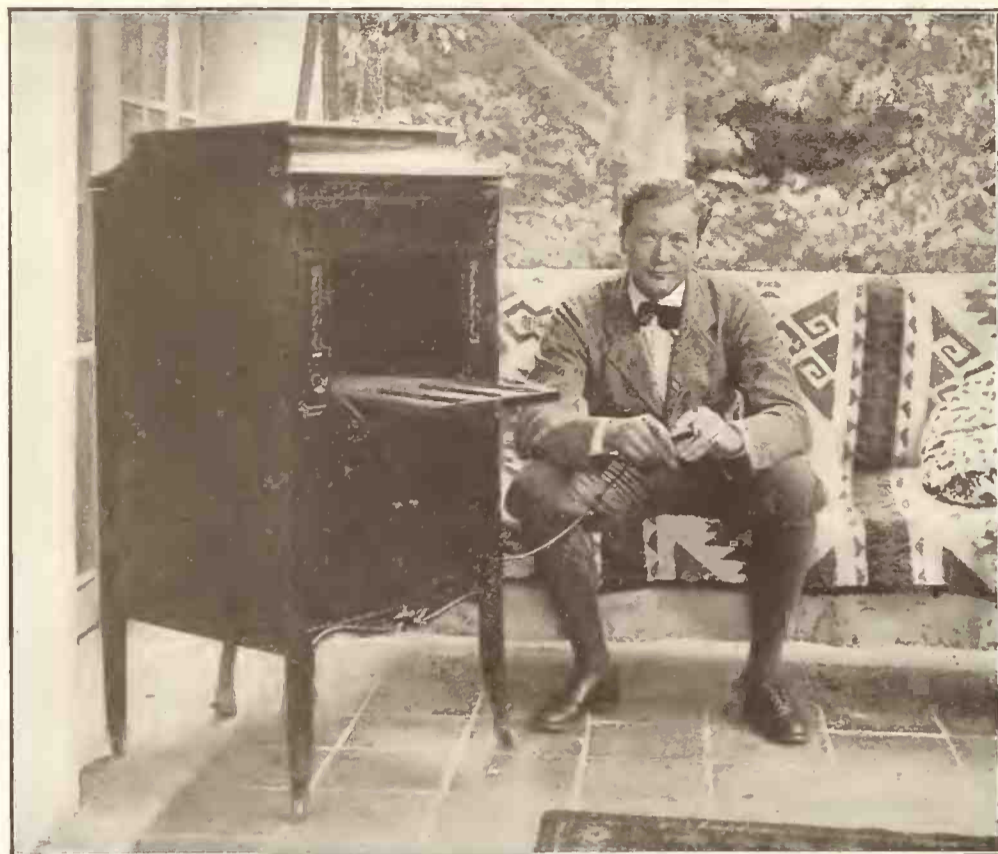

John Charles
THOMAS

*the gifted American
baritone, playing one
of his Vocalion Rec-
ords with the Gradu-
ola.*

*The Personal Touch
that THE GRADUOLA gives to*

The VOCALION

IT is the Graduola which makes the Vocalion *more than a phonograph*. This wonderfully effective tone-controlling device gives the person playing the record the power of shading the tone at will, with countless beautiful effects.

The Graduola, exclusive feature of the Vocalion, is a strong factor in interesting prospective buyers. Whether musically trained or not, there is a keen and universal fascination in playing records according to one's own ideas.

Natural tone-quality—distinctive case designs and the excellence of Vocalion (Red) Records give rich merchandising value to the Aeolian line.

Information regarding Vocalion phonographs and records will be furnished upon request. Let us hear from you.

Latest Vocalion (Red) Record Releases of Timely Hits

Say It With Music, from The Music Box Revue
—Fox-trot

Tenderly—Fox-trot *Selvin's Dance Orchestra*
No. 14239 \$.85

Dapper Dan *Irving Kaufman*
Ten Little Fingers *Ernest Hare-Billy Jones*
No. 14247 .85

It's You—Fox-trot
Hugs and Kisses—Fox-trot
The Newport Society Orchestra
No. 14249 .85

Bimini Bay—Fox-trot
I've Got the Joys—Fox-trot
Benny Krueger's Dance Orchestra
No. 14253 .85

Everybody Step—from The Music Box Revue—
Fox-trot
How Many Times?—Fox-trot
Al Jockey's Dance Orchestra
No. 14255 .85

THE AEOLIAN COMPANY

NEW YORK

CINCINNATI

CHICAGO

DAYTON

BOSTON

For record sales to new and old customers and good prospects besides—use the Christmas Gift Envelopes for Columbia Records this Christmas. They mean business for you!

**Columbia Graphophone Co.
NEW YORK**



COOL & SCHALLER OPEN NEW STORE

Many Friends and Representatives of Music Houses Attend Opening of Attractive Victor Shop Just Established in Upper New York

The latest addition to the music establishments in New York is the handsome Victor store formally opened at 181st street last week by Cool & Schaller. The store, while not the largest in the metropolis, is the equal of any in attractiveness. Twelve handsomely furnished sound-proof demonstration booths and a record rack with a capacity of fifteen thousand records, installed by the Unit Construction Co., are features of the establishment. A large electric sign, running across the entire front of the store, contains the firm name and the word "Victor." When illuminated the sign can be seen for several blocks in either direction.

Despite a driving rain the store was crowded on the opening night, October 31, to listen to a concert by the Hawaiian Band. Many friends of the proprietors were present, as well as a number of representatives of music houses in New York. Letters of congratulation were received from several who were unable to be present and floral wreaths were received from the Silas E. Pearsall Co., Victor distributor, the New York Talking Machine Co., and others.

Among those present were Theodore Morse, of Leo Feist, music publisher; Thomas F. Green, representing the Silas E. Pearsall Co.; Thomas McCready, of the Victor Talking Machine Co.; Paul Carlson and J. C. May, of the Chas. H. Ditson Co., Victor distributor, New York, and Jerome Harris, representing C. Bruno & Son, Inc., Victor distributors, of New York.

The proprietors of the establishment, Harold L. Cool and Warren G. Schaller, are well known in the section of the city where their business is located. Mr. Cool was formerly connected with his father in the music business in that neighborhood and he is well qualified to make a success of his new venture. Mr. Schaller, prior to entering partnership with Mr. Cool, was associated with his father in the silk business.

MUSIC A SUBJECT FOR THE SCHOOL

One of the speakers at the Wentworth County Teachers' Association, held recently in Hamilton, Ont., was Bruce A. Carey, supervisor of music in the Hamilton public schools. Taking as his topic, "Music a Subject for the School," Mr. Carey divided the benefits to be received by the pupils from musical teaching into four departments—the physical, mental and spiritual effects; its value as a developer of intellect; as a social developer and as a great leisure occupation. Three definite, practical suggestions were advanced. Two of these were purely local propositions, but the third is of national importance. Mr. Carey strongly urged the need of the talking machine and records in the equipment of public schools throughout the Dominion.

Remember, it's hard to fall down without a frown, but you can always get up with a smile.

SHELTON SALES CO. ORGANIZED

Will Act as Eastern Distributor for the Shelton Motor Made by the Shelton Electric Co.

The Shelton Sales Co. was recently formed to act as Eastern distributor for the Shelton motor made by the Shelton Electric Co., of New York City. Edward C. Boykin, formerly general manager of the Edison Shop, on Fifth avenue, opposite the Public Library, is general manager of the company, and offices have been opened at 299 Madison avenue, New York City. The company is specializing entirely in the sales of Shelton motors and in giving service to the dealer in its territory carrying these motors. Although recently organized, the company has already made substantial progress in the featuring of the Shelton motor in this territory.

MUSIC AS AN AID TO OPERATIONS

Talking machine music as an accessory to operations may soon be a fact in the opinion of Dr. Robert E. Farr, of Minneapolis. In a recent address to delegates at a medical convention in Milwaukee, Mr. Farr said: "Where major operations are performed with the aid of a local anesthetic rather than by the older method of etherizing, the patient remains conscious and alert, and gently played talking machine music has a decided value both in calming the patient and in supplying pleasurable sounds as an offset to the realization that he is being operated on."

ROOS BROS.' NEW CONNECTION

Well-known Salesmen Join General Phonograph Corp.'s Staff—Will Develop Needle Business

Julius and Nestor Roos, well known in talking machine sales circles throughout the country, have joined the sales division of the General Phonograph Corp. and will devote their activities exclusively to this company's needle department. The "Roos Brothers," as they are familiarly termed in the trade, have been associated with the talking machine industry for many years, and number among their friends dealers from coast to coast. An energetic sales campaign will be instituted by the General Phonograph Corp.'s needle division, and the Roos brothers will have unlimited opportunities to utilize their exceptional sales ability.

TO DISTRIBUTE CARDINAL RECORDS

CLEVELAND, O., October 28.—The Tiffany Phonograph Sales Co., of this city, has taken on the distribution of Cardinal records in the northern half of this State and active sales work is well under way. Representatives of the Tiffany Co. who will introduce Cardinal records in Ohio are: J. J. Kollie, H. R. Plotner, J. S. Horner and Joseph I. Hickley.

J. B. Tiffany, head of the Tiffany Sales Co., recently completed a solid eight weeks of travel in Ohio and reports a noticeable picking up in retail sales, especially in the smaller communities.



the Most Exclusive

Mr. Dealer:

It Is Not Too Late to Order

CHRISTMAS GIFT BAGS

Yet Offered



Yet Offered

Merchandise of unusual merit that has won the commendation of dealers everywhere. Beautiful containers for gift records (very heavy white paper). A prestige-building bag for the high-class dealer.



Design A

One Size Only

13x13 inches

No Strings

No Buttons

2-inch Flap



Design B

The bags are printed in two colors—red and green. Space provided for imprints, if desired, at bottom of panel.

If your sample has not been received PLEASE notify us at once.

Ask us to send you our price list, which explains the H-W service items.



HALSTED WILLIAMS CORP.

815-819 Monroe Street

Brooklyn, N. Y.





Queen Anne Console
\$225



Simplified Sheraton
Console, \$145



Adam Console
\$195

Where Can You Find a Line to Compare With Jewett Values?

JUST look at these three Jewett consoles—and then look at the list price beneath.

You probably think, from your knowledge of phonographs, that it is impossible to produce a really high-grade console at these prices.

But if you have that notion, you haven't seen the Jewett.

You cannot appreciate what remarkable value these beautiful consoles represent until you have seen and heard them for yourself.

Remember this: It is value that sells a phonograph today.

That's why our factory is running to capacity. That's why our dealers find it comparatively easy to sell Jewetts in the face of the keenest competition in the history of the business.

These consoles are made of five-ply, $\frac{3}{4}$ -inch panels *throughout*. You will be amazed at the fine cabinet work they represent. And the tone is one of rare sweetness—ample volume—unequaled clearness and freedom from vibration.

Why not see for yourself? That's the only satisfactory test. Write us today—there's no obligation.

THE JEWETT PHONOGRAPH COMPANY

General Sales Offices: 958 Penobscot Building

DETROIT, MICHIGAN

JEWETT
PHONOGRAPHS

Great Gathering of Victor Dealers Held in Dallas, Texas, Last Month

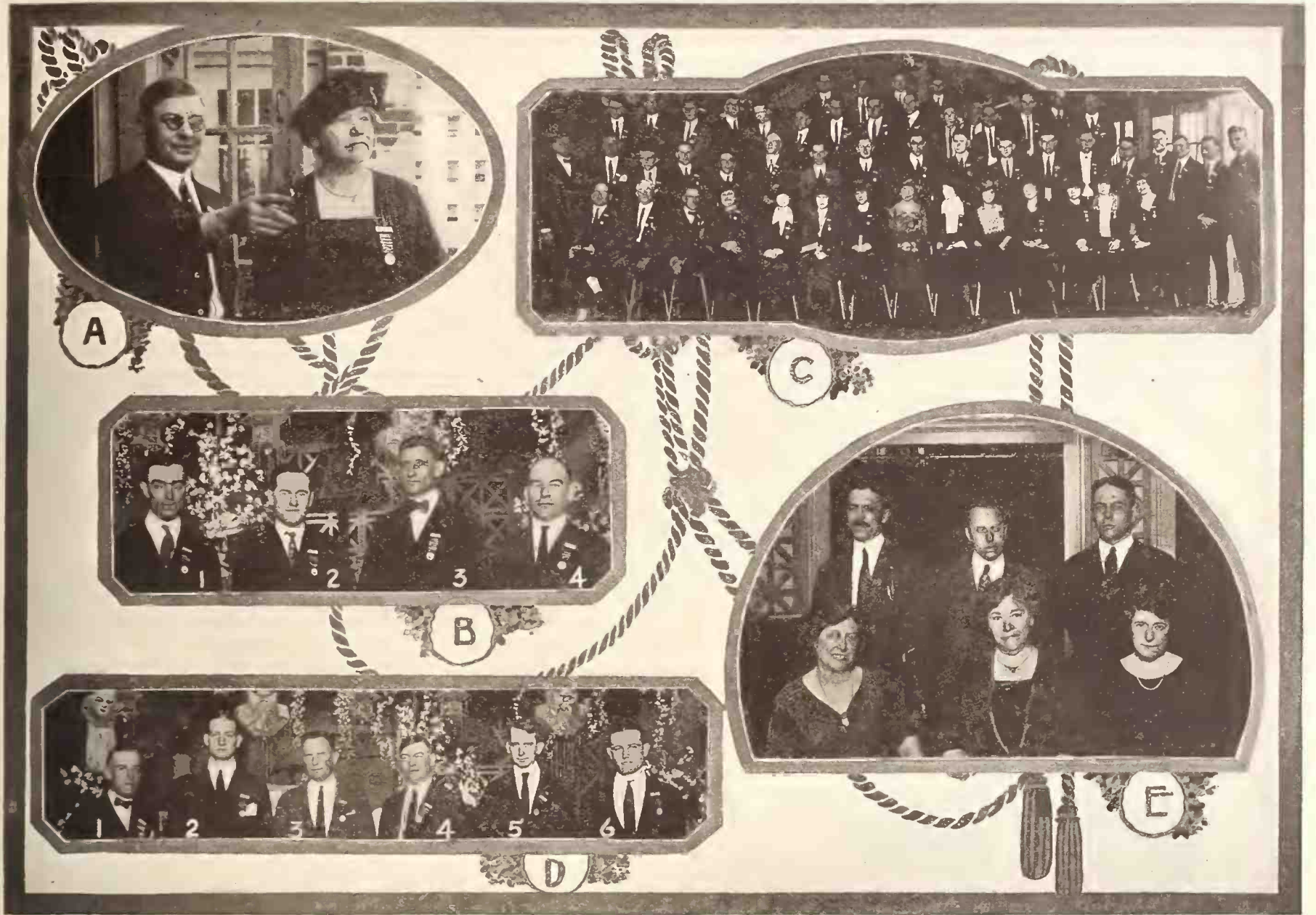

Some Snapshots From the Convention of the Southwestern Victor Dealers, Held in Dallas, Tex., on October 5, 6 and 7

A—Mrs. Frances E. Clark and Lester Burchfield Looking Over Dallas From Adolphus Hotel Roof Garden and Enjoying the View of That Rapidly Growing Southern City. B—(1) J. C. Deal, Angelo Furniture Co., San Angelo, Tex., Director Southwestern Victor Dealers' Association; (2) Wm. H. Beasley, H. V. Beasley Music Co., Texarkana, Ark., Vice-president; (3) B. W. Gragny, Bush & Gerts Piano Co., Dallas, President, and (4) Lester Gunst, Lester Gunst Co., Dallas, Secretary. C—Group Picture of Convention Delegates. D—(1) E. E. Hill, Traveling Representative Sanger Bros., Dallas; (2) F. L. Koons, Traveling Representative, W. G. Walz Co., El Paso; (3) J. W. Maxwell, Traveling Representative, Talking Machine Co. of Texas, Houston; (4) Lester Burchfield, Manager Wholesale Victor Department, Sanger Bros.; (5) W. B. Callaway and (6) E. E. Lock, Traveling Representatives, Talking Machine Co. of Texas. E—Victor Co. Representatives: Top Row—S. Dana Townsend, Educational Department; F. A. Delano, Director, Red Seal School; G. N. Swett, Traveling Department. Bottom Row—Miss Margaret M. Streeter, Mrs. Frances E. Clark, Director, and Miss Edith Rhett, of Educational Dep't.

ISSUES MUSIC WEEK PROCLAMATION

Mayor of Portland, Ore., Makes Official Announcement of Music Week Celebration in That City From November 27 to December 4

PORTLAND, ORE., November 4.—Portland's mayor, George L. Baker, has issued an official proclamation, setting aside the week of November 27 to December 4, inclusive, as Music Week. Present at the signing of the proclamation were Leslie Cranbourne, chairman of the Music Week Committee; L. S. Pilher, national community song service representative of the Community Service, and members of the advisory council. Mo-

tion pictures of the event were taken, which will be exhibited throughout the State of Oregon. The proclamation is as follows: "To the public: In furtherance of the great cause of music the week of November 27 to December 4, inclusive, is hereby officially designated Music Week in the city of Portland. All persons are urged to co-operate in the movement, which has as its purpose the introduction of more and better music into our every-day life.

"Music is the basis of the finer things in life. It is the symbol of peace and harmony, the greatest elements in human experience, and its development of all that makes for better citizenship, better morals and better conditions gen-

erally. Without these life is a failure. With these life is better and sweeter.

"Therefore, it is every man's duty to do his part toward making Music Week the success such an undertaking deserves.

"George L. Baker, Mayor."

FILES SCHEDULES IN BANKRUPTCY

Bessie R. Lubin, dealing in talking machines and records at 1773 Lexington avenue, New York City, recently filed schedules in bankruptcy here, showing liabilities of \$3,519 and assets of \$3,000. The assets represent the stock of the establishment.

REMEMBER—They Sell Well—

OKeh Records

That well-balanced monthly release that enables OKeh Records to take the lead in sales

J. K. POLK FURNITURE CO.

294 Decatur Street, Atlanta, Ga.



**A Diversified Variety of Designs
for the Christmas Trade**

Windsor Phonographs to suit every
taste at a wide range of prices—and
every one

*The Windsor
Phonograph*

—which means a perfect musical instru-
ment and a beautiful piece of furniture.

WINDSOR FURNITURE COMPANY

1420 CARROLL AVENUE

CHICAGO



The Windsor
 Furniture Company
 Chicago, U. S. A.

has been making good furniture since 1885. They are the oldest makers of

CONSOLE PHONOGRAPHS

Chicago Salesrooms:

1411 So. Michigan Avenue

Eastern Distributors:

HYMAN BROS. & COMPANY
 47 W. 34th Street, New York City

Exhibited January, 1922, and succeeding market season in

BLODGETT BUILDING
 Grand Rapids
 Mich.



ASK TO HEAR IT



THREE O'CLOCK in THE MORNING

Tempo di Valse Lente



It's three o'clock in the morn - ing.

The WORLD FAMOUS CHIMES WALTZ THAT IS MOVING A MILLION FEET

"You can't go wrong with any 'Feist' song"



RECORDS MUST BE RIGHTLY PACKED

Post Office Orders That Improperly Prepared Parcels of Records Be Refused for Mailing—Applies Chiefly to Shipments by the Public

WASHINGTON, D. C., November 4.—The Post Office Department has notified postmasters and other employes of the service that parcels containing phonograph records improperly prepared to withstand ordinary handling in the mails should not be accepted for transmission therein.

The attention of the office of the Third Assistant Postmaster General has been invited to the fact that parcels containing records are being accepted for mailing and insurance, although improperly prepared without any cushioning material to absorb shock incidental to transportation.

In a letter addressed to the officials and employes of the postal service the office states that "As phonograph records are of exceptionally fragile nature, the acceptance of such parcels improperly packed will result in claims for indemnity being filed covering such parcels as are insured or sent C. O. D. The co-operation of postmasters at all offices, therefore, is requested, with a view to acquainting patrons transmitting phonograph records by insured or C. O. D. mail as to the manner in which such parcels should be packed to withstand ordinary handling in the mails. Phonograph records should not be accepted unless the contents thereof are fully protected by sufficient cushioning material."

It is understood that the new regulation applies chiefly to individuals who have occasion to mail records, for dealers in records practically without exception see to it that they are carefully protected against breakage by the use of corrugated cardboard.

The Phonograph Hospital is the name of a new talking machine repair business operated by William P. Bennedum, at 237 Main street, Johnson City, N. Y.

STARR EXHIBIT AT VIRGINIA FAIR

Starr Pianos and Phonographs Displayed in Richmond, Va., Attract Much Attention

RICHMOND, VA., November 3.—Hundreds of visitors at the Virginia State Fair, held in this city the early part of the month, were attracted by the interesting display of Starr products in charge of H. Wallace Carner, factor for the Starr Piano Co., Richmond, Ind. Starr-made



Exhibit of Starr Line at Richmond Fair pianos and Starr phonographs were arranged to make an effective exhibit and Starr signs, window cards and placards had a prominent place, as did the Starr "Singing Throat and Horn" of silver grain spruce.

The style XV table model phonograph, which can be used as a writing desk and library table, as well as a phonograph, was also on display and occasioned a great deal of comment. H. Wallace Carner, who was in charge of the exhibit, was well pleased with the results.

RECEIVER APPOINTED

Fordyce E. Suderley, of Newark, N. J., has been appointed receiver of the Phonograph Control Corp., which has its headquarters in that city.

THE ADVERTISING MAN ANALYZED

Thirteen Requisites of the Successful Advertising Man in "Talker" or Other Fields

The thirteen requisites of the successful advertising man have been summed up by one of the elect as follows:

1. Good business judgment.
2. A keen sense of markets, marketing and merchandising; a sales sense.
3. Ability to organize his time, his work and his department.
4. Ability to co-operate with his executives, department heads, agency.
5. Ability to take advice and counsel from others, realizing that his plans may be faulty and he can't always be right.
6. Ability to balance the creative (spending) and the practical (expense or cost).
7. Ability to visualize his work from consumer and dealer eyes.
8. Ability to plan and to co-ordinate his plans into practical, workable, successful campaigns.
9. Ability to increase sales by: (a) Increasing the consumer acceptance of his trade-mark, name and product. (b) Making it convenient for the public to buy his goods (distribution and identification). (c) Making it easy for the dealer to tie up to the line (national tie-up window, stock, etc.). (d) Impressing his name and product on the public consciousness, and keeping it impressed by dominant persistent publicity and advertising.
10. Ability to make good with the sales force.
11. Ability to balance advertising expenditures with sales volume.
12. Ability to quickly turn a favorable event or circumstance into a publicity force of value for his firm.
13. Ability to sense and to select the forms, vehicles, media and methods of advertising best suited to his product, his means and HIS PROBLEM, and to use them efficiently.

GLORIA REPRODUCER—AN IMPORTANT MESSAGE

A sound-box and diaphragm of entirely new principles

After four years' use and exhaustive test the GLORIA REPRODUCER is now placed on sale, with VOLUME—NATURAL TONE—NON SCREECH—NON BLAST and improvement with age.

The diaphragm of SPUN aluminum $\frac{2\frac{1}{2}}{1000}$ of an inch thick. Hear a cornet solo, piano, violin, cello and soprano voice, with the absolute fidelity of the original.

To the trade: The Gloria Reproducer will be shipped in sample lots for \$3.25. Tone Arm and Sound-box \$6.00. Send for yours.

Remittance must accompany all orders for samples

GLORIA PHONOGRAPH CO.

Factory
226 15th Street

Salesroom
559 Fifth Ave., Brooklyn, N. Y.

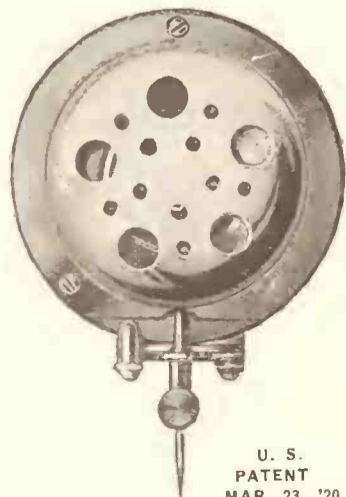

Ready for use

U. S.
PATENT
MAR. 23, '20

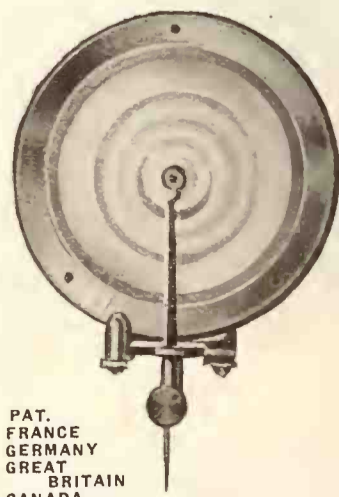

PAT.
FRANCE
GERMANY
GREAT
BRITAIN
CANADA

Open face

HOW RECORDS AIDED YOUNG TENOR

Allan Rogers, Protege of Bonci, Gains Much Valuable Training While Studying the Voice of That Noted Artist Through His Records

Allan Rogers, a young American tenor and protege of Allesandro Bonci, the famous Italian opera singer, is an enthusiastic advocate of the talking machine as a means of musical culture. He frankly confesses that a very large percentage of the technique he has acquired and the style he has developed is due solely to his careful study and constant practice of the methods of the celebrated artists as reproduced by the talking machine.

Mr. Rogers, who is at present filling a number of recital engagements, after being advised by Bonci to give music his serious study with the idea of making it a life vocation, placed himself under the tutelage of vocal instructors in his native city of Chicago. He secured from Bonci a list of the great tenor's most difficult solos and arias that have been reproduced on the talking machines, and ultimately acquired a library of records in which the voices of all the great singers of tenor quality are represented.

It was his custom to sit by the Grafonola during the rendition of a number in which he himself was preparing for public performance, and listen minutely to the phrasing, shading and technical achievements. Thus, while Bonci sang the "Woman Is Fickle" number from Rigoletto, or his great aria in "La Somnambula," the young singer made careful mental and written notes of the masters of opera methods. He never, in those early days of his preparation for concert and oratorio, studied a single number without first having made an effort to secure its reproduction by the voice of some noted singer. Sometimes he found his own methods best adapted to his own voice, for he learned from every record some bit of vocal technique that could be employed in his own work. For hours at a time he sat alongside of the graphophone, playing and replaying, with constant reiteration, the same phrases and passages, until he was able to reproduce them satisfactorily. This system was adopted at the suggestion of Bonci, and has since been taken up by many other singers of note. In Mr. Rogers' opinion this is the shortest cut to voice culture the world has ever known.

ANTICIPATING, NOT REGRETTING

Many customers who had purchased on the instalment plan, one concern found, failed to make good their promises of payment, says R. A. Burnham in System. The credit department, therefore, decided that a more rigid plan of correspondence should be adopted.

Now, whenever a customer makes a promise to pay, that customer's name, address and the contract number are written on the proper credit man's correspondence memorandum under a date three days in advance of when the promise is to be made good. And when the credit man turns to this date he straightway looks up the customer's contract and its provisions and writes to the customer.

These three days give the company a chance to get a letter to the customer just a little ahead of time, reminding the party in a cordial way that "his payment will certainly be welcome," and as a result there is prompt payment.



Sound Boxes to fit Victor and Columbia. Samples, \$8.60 each.
Tone Arm and Sound Box, Per Set \$1.35.
We carry in stock parts for all makes machines. Write for our catalog and prices.
Pleasing Sound Phonograph Co.
Manufacturers—Jobbers
204 East 113th St., New York City
Jobbing Territory Open

ODEON ARTIST ON CONCERT TOUR

Ferez von Vescey, Violinist, on Successful Tour—Odeon Records Are in Demand

Ferez von Vescey, prominent Hungarian violinist, who is now on a concert tour in this country, has made several recordings on Odeon records, and Odeon dealers are making plans to feature these records during his stay here. The American Odeon Co., New York, is co-operating with its dealers in promoting the sale of these records, and is furnishing them with timely bulletins and circulars showing the names of the selections recorded by Von Vescey. This list of recordings comprises a wide variety of well-known compositions by the foremost masters, among which are Handel's "Largo" and the "Foglio D'Album," a work by Von Vescey himself. His recitals in New York were a success.

Analysis of your business methods may sometimes disclose better ways of getting results.

RECEIVERS FOR LYRAPHONE CO.

U. S. District Court Places J. L. Smith and Mark A. Samuels in Charge of Company

Joseph L. Smith and Mark A. Samuels were appointed receivers for the Lyraphone Co. of America, Newark, N. J., manufacturers of Lyric records, on October 24, by order of the U. S. District Court of the Northern District of New Jersey, upon the petition of Charles Dick, one of the largest stockholders of the company. It is understood that the company will continue operations for the present at least.

MILWAUKEE FIRM INCORPORATES

A charter of incorporation has been granted to the Zefira Phonograph Co., of Milwaukee, Wis., under the laws of that State, with a capital of \$25,000, consisting of 250 shares of stock, with a par value of \$100. Incorporators are: G. Zembrzusi, Thomas Dombinski and Stephen Roman.

CONNORIZED

PHONOGRAPH RECORDS

10-inch *DOUBLE DISC*

WITH A POPULAR HIT ON EACH SIDE

Durable — Clear Tone — Musical

A number of the most popular hits of the season as well as a splendid offering of Italian Selections are included in the list for November.

- 3019 { Bimini Bay. Song, Orch. Accomp.,
Vocal { Sung by Irving Kaufman
- 3020 { Wha Wha. Song, Orch. Accomp.,
Vocal { Sung by Arthur Fields
- 3021 { Yoo Hoo. Song, Orch. Accomp.,
Vocal { Sung by Arthur Fields
- 3022 { When the Honeymoon Was Over. Song, Orch.
Vocal { Accomp.Sung by Sam Asb
- 3023 { Sweet Lady (From "Tangerine"). Fox-trot.
Inst. { Lanin's Famous Players
- 3024 { Say It With Music. Fox-trot,
Inst. { Lanin's Famous Players
- 3025 { When Frances Dances With Me. Song,
Vocal { Orch. Accomp.Sung by Arthur Fields
- 3026 { Ten Little Fingers and Ten Little Toes (Pease-
Vocal { White-Shuster-Nelson). Song, Orch. Ac-
comp.Sung by Charles Harrison
- 3027 { Peggy O'Neil. Waltz,
Inst. { Waldorf-Astoria Dance Orchestra
- 3028 { Why, Dear? Fox-trot.....Merry Melody Men
- 3029 { Tuck Me to Sleep (Lewis-Young-Meyer).
Inst. { Fox-trot.....Harry Raderman's Orchestra
- 3030 { My Sunny Tennessee (Kalmar-Ruby). Fox-
Inst. { trot.....Benny Krueger's Orchestra

- NUOVI DISCHI ITALIANI**
- 121 { Mistere 'E Marechiere (Raffaele M. Grimaldi-
L. Donadio). Acc. Dell' Orchestra Na-
10 in. { poletana.....M. Scialpi, Tenore
 - 122 { Tradimento 'E' Ammore (Raffaele M. Gri-
maldi-L. Donadio). Acc. Dell' Orches-
tra Napoletana.....M. Scialpi, Tenore
 - 123 { Sorrisi Di Culla (J. Cassara). Mazurka,
10 in. { Orchestra Degli Arditi
 - 124 { Stella Lucente (D. Jetti). Mazurka,
Orchestra Degli Arditi
 - 125 { Diamond Walzer (J. Tripepi),
10 in. { Orchestra Degli Arditi
 - 126 { Tea Party Walzer (L. Vitak).
Orchestra Degli Arditi
 - 127 { Cara Piccina (Dovio-Lama). Acc. Dell' Or-
chestra Napoletana.
128 { Frances De Palma, Soprano
 - 129 { Come Le Rose (A. Genise-G. Lama). Acc.
10 in. { Dell' Orchestra Napoletana,
Frances De Palma, Soprano
 - 130 { E. Caruso' O Rre D' 'O Canto (L. Cica-
L. Canora). Acc. Dell' Orchestra Na-
125 { poletana.....M. Scialpi, Tenore
 - 131 { Cavalleria Rusticana (Mascagni). Intermezzo,
10 in. { Symphony Orchestra (P. Florida, Direc.)

CONNORIZED MUSIC CO.

ALSO MAKERS OF CONNORIZED MUSIC ROLLS

817 E. 144th St., - - - New York

UNITED MUSIC STORES

PHILADELPHIA

BALTIMORE



The Perfect Motor for Phonographs

THE SHELTON MOTOR

**Eliminates Winding—Never Runs Down—Noiseless—
Not A Winding Device—Gives A Smooth, Beautiful Tone**

After years of experimentation the Shelton Motor—the perfect motor for all phonographs—is on the market.

It transforms any phonograph—Edison, Victor, Columbia—into an electrically driven machine. No winding, no running down.

A light push on the turntable automatically turns on the current. Motor runs at a uniform, even speed, insuring perfect musical reproduction. *Absolutely noiseless.*

Can be installed in a minute. So small it can be carried in your pocket. *Invisible when lid is closed.*

Cost of operation less than five cents a month. Never gets out of adjustment. Guaranteed indefinitely.

Your customers will be intensely interested in this ideal phonograph motor and quick to see its advantages. Over 20,000 satisfied users today. Large, immediate profits in its sale for you.

Write today for name of nearest distributor.

SHELTON ELECTRIC COMPANY

16 EAST 42nd STREET

NEW YORK, N. Y.



TRADE NEWS IN BROOKLYN AND LONG ISLAND

Increased Sales of Machines and Records Reported—Jobbers and Dealers Perfect Selling Plans for Winter—Bettering Conditions Hurt by Bad Sales Methods of Some Dealers

Retail talking machine business in Brooklyn and Long Island has taken a decided jump this past month, as all dealers report an active demand, and this is especially true in the machine demand. Although record sales have not shown as great an increase they are bound to take a spurt soon, for, as one dealer stated, if people are purchasing machines they will surely be in the market for records.

There is considerable agitation in the trade over the activities of some dealers, who, it is claimed, are offering well-known makes of talking machines at prices far below the regular retail price. This price-cutting, especially at present, is unnecessary and legitimate dealers are endeavoring to eliminate this wholly unfair method of doing business.

Activity of Victor Dealers

The American Talking Machine Co., Victor distributor for Brooklyn and Long Island, is in the midst of a Fall activity that reflects the healthy demand that this company is experiencing for Victor products. R. H. Morris, general manager, states that it seems like old times again to see dealers so active, and he is very confident that business this Winter will be far beyond expectations.

Window Display Produces Sales

"A new idea a day" is the slogan adopted by the successful Victor store conducted by Owens & Gibbons at 10 Seventh avenue, facing Times plaza. Although occupying a limited amount of floor-space, every available inch has been utilized to the greatest advantage, with the result that customers are given maximum service. "Bob" Owens, brother of the elder Owens, one of the proprietors, was responsible for a timely Hallowe'en window display that was a riot of color, featuring the new November records, which attracted considerable attention. A flash system of lighting was effectively used, making the display visible for some distance away. Miss Marjorie Sybly, whose genial personality has made so many friends for this "up-to-date" store, has a wide experience in merchandising Victor products to her credit, and her thorough

VICTOR
RECORDS

The Last Quarter of 1921

WE are now nearing the end of the last quarter. Sales will, of course, come somewhat easier. But the wise Victor retailer will not lose sight of the fact that competition still exists. Energetic sales efforts must be continued. Raise your quota of sales and make the race swifter for yourself if not for others. Make this your largest holiday season.

To this end we offer our services.

G.T. WILLIAMS CO. Inc.

217 DUFFIELD ST. ~ BROOKLYN, N.Y.

VICTOR
RECORDS

knowledge of the Victor record catalog contributes largely to the success of this establishment.

New Sales Plan Proves Success

Kern's Music Store, Brunswick and Sonora dealer, at 292 Flatbush avenue, is very enthusiastic over the results of a mail-order campaign which was inaugurated a short time ago. An attractive circular was prepared in which a specially selected list of slow turnover records was shown, which was sent out, with an order blank attached, to a special list of old and new customers. A multigraph letter with a selling punch, describing the attached lists, completed the material used. As a stimulator of record sales this scheme has proved such a success that it is contemplated to make it a monthly affair, replacing the monthly supplement.

Will Concentrate on Two Lines

Otto Wissner, the well-known talking machine

dealer at 55 Flatbush avenue, is carrying on one of the most intensive sales campaigns ever inaugurated by this company. Heretofore he has carried several lines of talking machines, and a recent decision by the officials of the company to concentrate on the Victor and Sonora lines prompted this sale in order to liquidate the stocks of the other makes on hand.

Display Sells Period Models

Mills Bros., furniture dealers, at 1720 Broadway, who handle the Columbia exclusively, report that the demand for Grafonolas has increased materially the past month. William P. Esterling, who looks after the interests of this department, stated that business during the past few months had been slow, but all indications now point to larger sales for the Winter season. Recently the company featured the Columbia period models in a very attractive window display that proved instrumental in closing sales of Grafonolas of various types. Newspaper advertising was used to tie up with this display.

Moves to Larger Quarters

John Duhm, Victor dealer, who has been located at 1419 Myrtle avenue for several years, is moving his stock and fixtures to his new and modern quarters on Knickerbocker avenue. Mr. Duhm contemplated this change for some time, but it was not until recently that he was able to secure a lease of this particular location, which is considered one of the most desirable in this section of Brooklyn. As this new store is only four blocks away from the old address, all of Mr. Duhm's old and established clientele can be served as conveniently as before, and with new and up-to-date equipment this establishment will undoubtedly attract many new customers. A feature of the new quarters will be a "One-minute record sales service counter," which will be located near the entrance, where the purchase of a record can be made by the busy customer at a maximum saving of time.

Leases Adjoining Store

J. M. Quinn, who has featured the Sonora and Brunswick lines for several years, has recently taken over the store adjoining his present one at 1227 Broadway and combined the two into a most attractive showroom. With this new addition, Mr. Quinn secured the complete Edison Diamond Disc, and is devoting a large section of the new store to this line. In addition to eleven private record booths already in use, five large ones have been erected which will be used for the purpose of demonstrating machines. When alterations are completed this store will be one of the most attractive in Brooklyn.



AMERICAN
TALKING
MACHINE
CO.

VICTOR
WHOLESALE

BROOKLYN
NY

THE VICTOR DEALER

WHO WILL REAP THE MOST BENEFITS FROM THE SEASON WHICH IS NOW WITH US IS THE ONE WHO IS PREPARED AND WHO WILL ADVERTISE CONSISTENTLY IN A MANNER WHICH IS IN KEEPING WITH THE HIGH CLASS GOODS HE SELLS.

HAVE YOU ARRANGED YOUR ADVERTISING CAMPAIGN?

IS IT EQUAL TO THE MERCHANDISE YOU SELL?

"YOU'LL BE SURPRISED" to know that you may be one who is willfully encouraging a competitor to locate nearby.

A poorly equipped unprogressive establishment invites the competition of the live-wire dealer who will install such equipment as is manufactured by Van Veen & Company. Why not beat him to it by installing Van Veen service yourself, thus keeping him out of your field? A weak position invites attack.

We extend helpful terms to those worthy of credit.

VANVEEN & COMPANY INC.

12 YEARS OF STUDY AND EXPERIENCE IN
BUILDING AND PLANNING MUSIC STORES

· HEARING ROOMS · RECORD RACKS · COUNTERS ·

EXECUTIVE OFFICE
47-49 WEST 34th STREET
NEW YORK CITY

SALES OFFICE
1711 CHESTNUT STREET
PHILADELPHIA

Why the "Talker" Business Should Be "Clean"

By R. C. HAMILTON, Mgr. Rio Talking Machine Shop, New York

The talking machine business has always been spoken of as "clean," and there is no doubt that, taken as a whole, it is a remarkably clean business. However, many dealers have confined the meaning of the word clean to its ethical sense, which is a grievous mistake.

Much is said of "woman's refining influence" and there is a great deal left unsaid on this subject. If every dealer were fortunate enough to have women folk to advise him about arranging his shop and keeping it really "clean" in the physical sense the trade would be much benefited. While many dealers make an effort to keep their establishments in the best possible condition it is rather too much to expect a man to be much of a good housekeeper (though some of the ex-service men still retain rather good ideas of what real neatness means).

Bearing in mind that women constitute the larger part of the buying public it would seem advisable to cater to their ideas in every possible way—and as it is an easy matter to achieve cleanliness of store and window it seems strange that so many dealers neglect this.

Well-polished instruments are certainly more

attractive to a prospective buyer than those with dull nickel and smudged cases. Likewise a fresh-looking window, with crisp cards and bright posters, will certainly prove a bigger "puller" than one with dead flies decorating the floor and with dirty and carelessly hung posters.

In shops finished in cream or light gray a chamois and Ivory soap will do wonders.

Change your window trim so frequently that it will not have time to become dingy-looking.

Look at the chairs in the booths (especially if they are painted a light color) and see that they are not full of finger prints at the top of the back.

Keep the catalogs and monthly supplements so that they are not dog-eared and sloppy in appearance.

In a well-regulated establishment every phonograph that may be used for demonstration purposes is examined every morning to see that it is timed properly and in good running and mechanical order, and dust and all finger marks polished off. It is just as necessary that this daily inspection be done by the small town dealer as by those in the large cities.

If you are disposed to consider all this "finicky"—just convince yourself by asking your wife or mother or your sweetheart to look over your store and give you her candid opinion of it—you will be surprised unless you are one of those who have already realized the importance of little things in business.—Sonora Bell.

"DREAM PICTURES" INTEREST

Hand-painted Slides Effectively Synchronized to Music of Victor Records Shown at Meeting of Victor Retailers in Newark Recently

The Victor Retailers of New Jersey held their monthly luncheon and meeting on Tuesday, October 18, at the Robert Treat Hotel, Newark, N. J. Following the luncheon a demonstration was given by Bronson DeCou of his "Dream Pictures." These are especially selected, hand-painted slides thrown on a screen synchronized to the music of a number of Victor records. Mr. DeCou is showing his pictures in New Jersey territory at schools, halls and dealers' stores by arrangement with Victor dealers in various localities. The entertainment has been the means of attracting record buyers to the stores in the territory where they have been shown and are a most novel, interesting and constructive contribution to retail activities.

The following members of the Association attended: H. A. Glasser, James McGarry, J. A. Johnson, H. N. Truesdell, C. McCollum, James J. Merritts, Joseph Schink, A. Stark, Louis Frey, H. P. Armstrong, Charles J. Honsberger, W. S. Beebe, E. P. Perkins, J. L. Spillane, R. Michanoff, Mrs. E. G. Brown, A. Galuchie, Daniel Egan, Fred G. Loeffler, S. Semels, Henry Rau, Clark M. Price, Irwin Moser, N. O. Brown, J. E. Tomlinson, C. A. True, H. B. Merritt, L. W. Collings and H. A. Lamour.

H. J. Wernsman, of Lacon, Ill. has opened a talking machine and optical business in Mendota, Ill., which will be modern in every way.



PHONOGRAPH CASES Reinforced 3-ply Veneer

The Standard Case for Talking
Machines and Records

Let us figure on your requirements

MADE BY

PLYWOOD CORPORATION, Goldsboro, N. C.

Mills in Va., N. C. and S. C.



HERE IT IS!

The
**FLETCHER UNIVERSAL
TONE ARM and REPRODUCER**

Gives Proper Playing Weights for All Records. No Adjustment Screws or Springs.
SAMPLES \$8.00 Specify 8½" or 9½" arm

FLETCHER-WICKES CO., 6 East Lake Street, Chicago, Illinois

THE McLAGAN FURNITURE CORP., LTD., STRATFORD, ONTARIO, EXCLUSIVE CANADIAN AGENTS

Getting in Touch With Prospective Buyers

By CHARLES OLIVE, of Olive Bros., Wilmar, Minn.

Every merchant knows that getting in touch with prospective buyers is one of the most difficult problems of his business. When he has found a lot of persons who are in the market for a certain article he has a good chance to make sales if what he has to offer is of real value and is sold at a fair price. The following plan, which we worked last Winter to sell phonographs, proved to be unusually effective for discovering possible buyers.

The main feature of the "scheme" was a drop-box to hold a number of address cards. The box, made of wood, had a compartment in the lower end for holding a pack of blank cards, and there was a slit in the front side for dropping the cards into the box. On top of the box was a hinged cover for removing the cards. The contrivance was set up on a conspicuous place in the store, and immediately above the box was hung this sign: "Free Cigar Holder! Write the names and addresses of any persons who you know are figuring on buying a phonograph, or who do not own a machine, on one of these cards. Drop card in box and ask for free cigar holder."

It was surprising to see how many persons there were that could recall the names of friends and neighbors who were in the market for talking machines. Each person, of course, who filled out a card really got a cigar holder free. We purchased a supply of fairly good holders, each with our name and address thereon, at a low price, and their cost was truly cheap advertising. Every evening there was quite a bunch of cards in the box, and the names they contained represented mostly prospects of the right kind, too.

To each person named we sent the following letter: "You will soon buy a phonograph, for everybody else is doing it. The talking machine is the most popular musical instrument of today, for the reason that it both entertains and educates without any effort on the part of the user. We have high-class machines at popular prices just now. Come in and hear these grand instruments. They will surprise and please you. Or ask us to send you our catalog. We will be pleased to put a machine in your home on trial. Cordially, Olive Bros."

Many of the prospects soon came in and looked over the machines, and the result was

quite a few immediate sales. A number answered by card, asking for catalogs. We called on those who did not answer at all, to find out if there was any possible chance of a sale among them. To all the others we sent a catalog ten days after we had mailed the first letters. Quite a few of those receiving catalogs asked for a machine on trial, and outright sales were made continually. Altogether we sold thirty machines during the Christmas season. I consider this a good record for a town of five thousand population where there are half a dozen other dealers handling phonographs.

MARKSON BROS. OPENING IN UTICA

UTICA, N. Y., November 4.—The new Columbia Grafonola department of Markson Bros., 644 Bleeker street, this city, was formally opened last week with a band concert and solos by well-known singers in various sections of the city. Large crowds attended each performance, which included songs by Lew Brown, of the J. H. Remick Music Co., and Lew Emmel, of the Shapiro-Bernstein Co., who sang his latest song hits, "Just Like a Rainbow" and "I Ain't Nobody's Darling."

The meek may inherit the earth, but not until everyone else is dead.

SOMETHING ENTIRELY NEW IN TONE ARMS
THE FLETCHER "STRAIGHT"



**STRAIGHT INSIDE—Taper Outside
BALL BEARINGS THROUGHOUT
NEW DESIGN NEW CONSTRUCTION**

Yes, it is universal and equipped with the Regular Fletcher Reproducer, giving the same natural tone quality as heretofore

Made in two lengths, 8½" and 9½"

SEND FOR PRICES AND TERMS



FLETCHER-WICKES COMPANY

6 EAST LAKE ST.

CHICAGO



"You've Made a Chicken of Your Mother (But You Can't Make a Goose of Me)" and the great success from *Snapshots of 1921*, "Saturday," are sung by Nora Bayes. Why say more about A-3471?

**Columbia Graphophone Co.
NEW YORK**

TRADE BETTERMENT IS BROADENING IN SAN FRANCISCO

Music Week Quite an Event—Association Smoker Attracts Crowd—Sonora Distributors Entertain Thirty Dealers of California—Caruso Honored—Bubble Book Parties in Vogue

SAN FRANCISCO, CAL., October 30.—There is not a great deal of jazz to business at present, but the retail market has continued to improve steadily, though slowly. There are still too many uncertain factors disturbing the commercial world to permit any general feeling of confidence just now and thus business initiative is cramped and crimped to a large extent. The retailers have pretty generally provided for a normal holiday activity, however, and it cannot be truthfully said that the trade is simply content with marking time.

Celebration of Music Week

There will be a "Music Week" in San Francisco, October 30 to November 6, and the trade is trying hard to take an interest in this proposition. There have been so many expositions of one kind or another in the city of late that the task of promoting public interest in anything new of this character is brain-racking. But "Music Week" will no doubt do something to enliven the demand for musical merchandise and it may result in generating a renewed supply of pep in the phonograph fraternity.

Association Holds a Smoker

The Music Trades Association of Northern California held a very successful dinner and smoker at the Stewart Hotel in San Francisco on the night of October 25 and a fairly large attendance was present. The principal speaker of the evening was George Victor, Pacific Coast sales manager of Yawman & Erbe, who delivered a spirited address on modern methods of salesmanship. The smoker following the dinner was enlivened by many numbers of a professional and amateur character, among which was a vaudeville act entitled "The Piano Movers," performed by J. J. Black, Charles Dean, Billy Lawrence and Clarence Anrys, of the Wiley B. Allen Co., and Billy Morton, of Sherman, Clay

& Co., and Al Goetz, of Kohler & Chase. F. P. Corcoran, Pacific Coast sales manager for the Brunswick Co., made a hit with his Hebrew impersonation monologue, and Harold Pracht, sales manager of the Wiley B. Allen Co., brought down the house by reading a burlesque essay dealing with the music trade from a pathological standpoint. There were also several musical numbers by professionals and others.

Giving Bubble Book Parties

The Emporium is giving Bubble Book parties this week at the store. The parties are given under the direction of Miss Grace, who represents the publishers and who has been giving similar entertainments in Seattle, Portland and other cities.

Walter S. Gray, the "Needle King," has just left for a month's trip in southern California.

Feature Edison and Vocalion Records

The City of Paris has been featuring the Edison and Vocalion phonographs in their show windows this month. The presence of Miss Aileen Stanley on the Orpheum stage here did not a little to stimulate the demand for her fine Vocalion records. W. S. Storms, manager of the City of Paris phonograph department, sold a Sonora baby grand to Washington B. Vanderlip recently and Mr. Vanderlip will have this instrument for a musical companion in Russia, where he is again to live for some time to come.

Sonora Dealers Entertained

The Sonora distributors on the Coast entertained over thirty Sonora dealers of California at a luncheon at the Palace Hotel in San Francisco this month. The guests were welcomed by F. B. Travers, the Pacific Coast manager for the Sonora Co., and he called upon W. S. Storms, of the City of Paris; A. W. White, of Berkeley, and Morley Somers, of the Sonora Phonograph Shop, San Francisco, for short speeches.

H. Sieroty, the manager of the talking machine department of the Eastern Outfitting Co., San Francisco, is on his way back to San Francisco after an extended European tour.

A recent visitor to the Coast is W. W. Chase, president of the Pathé Frères Phonograph Co.

Long Showing New Phonograph

The "Melodiola," the phonograph invented by Frank B. Long, the inventor of various improvements in the piano and player-piano, is attracting considerable attention in San Francisco. Mr. Long has the machine on sale at 534 Sutter street, and it is manufactured in San Francisco.

Concert in Honor of Caruso

Paul Steindorf, the distinguished orchestra leader, is giving a series of popular concerts at the Oakland Auditorium. The first concert, on October 13, was one in honor of Caruso. Caruso records were played on the Victrola, accompanied by the orchestra, and the numbers thus rendered met with prolonged applause.

Another musical event in which Mr. Steindorf figured this month was that of a Magnavox demonstration. While Mr. Steindorf's orchestra played on the roof of the Fairmont Hotel in San Francisco, the Magnavox reproduced the concert in the business district of Oakland across the Bay. The wireless telephone transmitted the music to the Magnavox. The Magnavox also reproduced two solos sung by Miss Elfrieda Steindorf, accompanied by her father's orchestra, and an address by Mayor Rolph of San Francisco.

Uses Delivery Automobile

Ben Adkins, of the Remick Song Shop, San Francisco, is giving extra special service to his customers these days by means of a delivery automobile gaily decorated on the panels with reproductions of the well-known Columbia insignia. Mr. Adkins enjoys a large telephone trade on Columbia records and quick delivery is necessary in many cases.

The man who corners all the conversation rarely corners anything else.

Complete Stock and Excellent Service on

OKeh Records

"SERVICE"

THE ARTOPHONE CORPORATION

1103 OLIVE ST.,

ST. LOUIS, MISSOURI

Wholesale distributors of OKeh Records for the South and Southwest



GENERAL PHONOGRAPH CORPORATION

OTTO HEINEMAN, *President*

25 West 45th Street

New York City, N. Y.



Did you read Charles M. Schwab's address on "Prosperity," delivered recently at Atlantic City? Prosperity is rapidly returning, and the phonograph trade *will* share in this prosperity to the fullest extent.

Now is the time to go after business. Make things hum.

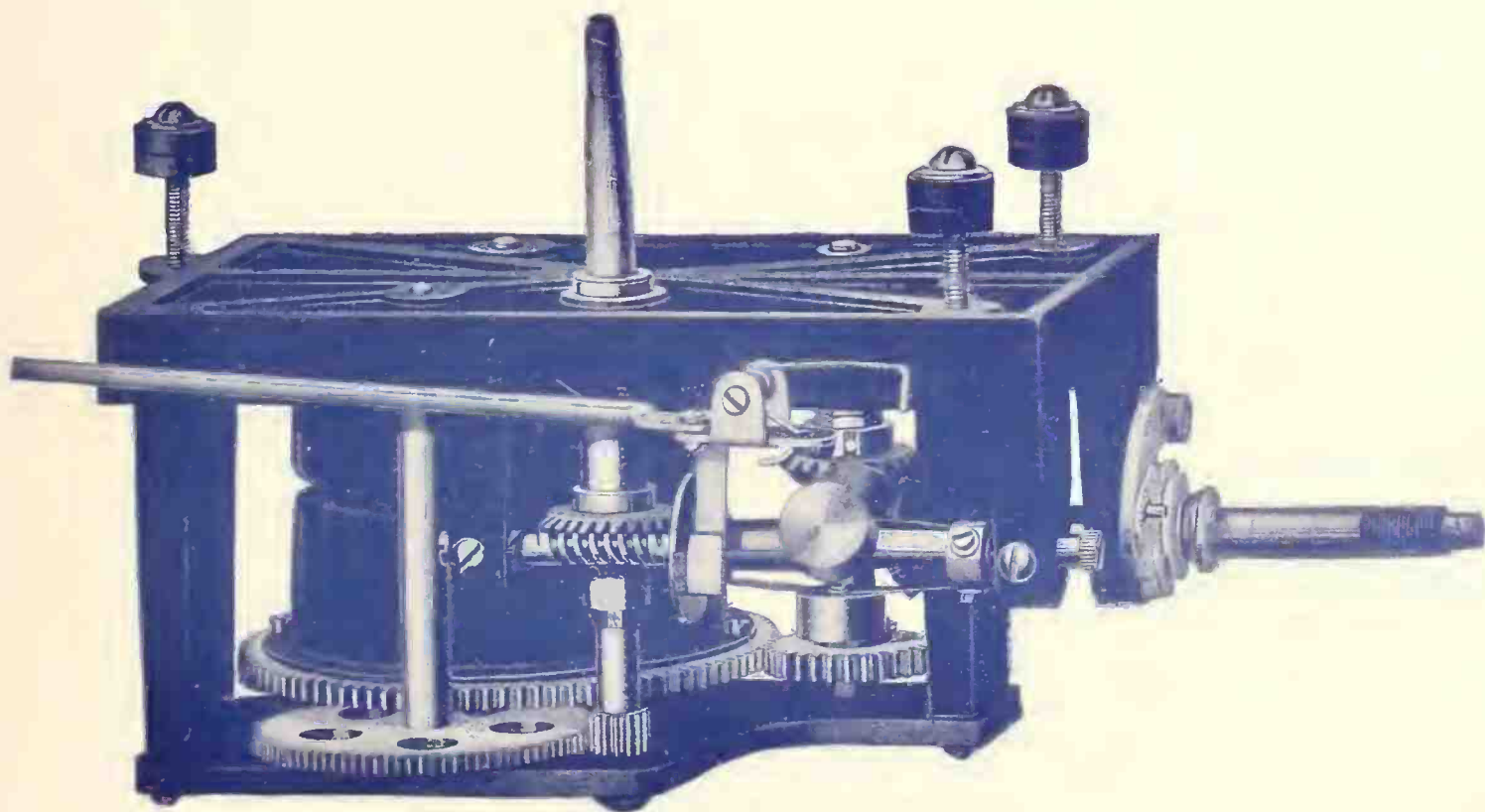

HEINEMAN MOTOR No. 77

Use HEINEMAN and MEISSELBACH Motors, Tone-Arms and Sound Boxes—and you and your dealers will be satisfied.

ASK FOR NEW PRICE LIST

The Trade in **BOSTON** and **NEW ENGLAND**

JOHN H. WILSON, Manager
324 WASHINGTON ST., BOSTON, MASS.

Boston, Mass., November 7.—From the appearance of some of the jobbing houses as well as the retailers it is not hard to believe that the feeling is pretty general that there is a good season ahead in the talking machine business. One thing is apparent: the retailers have taken the word of the wholesalers that the time is coming when machines and products in general are to be scarce, and rather than get caught, as they have in some past seasons, orders are being placed early. Generally improved conditions have done their share to stimulate the talking machine business, and the feeling is now widespread that better times are fast on the way.

Frank S. Horning Elected President

The annual meeting of the New England Music Trade Association brought to the fore the



Frank S. Horning

talking machine industry of this section, and a special honor was accorded it through the election to the presidency of Frank S. Horning, of F. S. Horning & Co., Inc., Victor dealers, at 22 Boylston street. Mr. Horning has been in Boston only a few years, but he has made a lot of friends in that time and he has been able to develop a splendid business at this downtown address. The dinner was attended by about one hundred members and guests and was served at Young's Hotel following the annual meeting. Some of the talking machine men who were active in taking part in the evening's success

were A. J. Cullen, of the Lansing Sales Co., Inc.; W. W. Radcliffe, of the Hallet & Davis Co.; Ernest A. Creese, of the C. C. Harvey Co., and R. V. Davis, of the F. C. Henderson Co. The guests at the dinner were Hon. Guy Ham, who spoke on "The Business Outlook," and Professor Harold Whitehead, of the department of sales relations at Boston University, whose topic was "The Lost Art of Salesmanship."

Mr. Ham presented two pictures, one of the pessimistic sort, the other of the optimistic character. Of the adverse elements touching present-day conditions he pointed out the country's unscientific system of taxation; our relation with other countries, with special reference to banking facilities, or the lack of them; the liquidation of labor, which has got to take place before a normal condition can be arrived at; and the rates that money has been obliged to exact in order to do business, and he believed it would be a long time before the rates obtaining before the war will again become operative.

As to the favorable signs, these things were noted: The people have more savings in the banks and institutions than ever before in the history of the country, which has a great purchasing power, and which is to be released at no distant date; America is now a creditor nation and not a debtor one; the immense size of the gold reserve now held by the United States, something that has great possibilities for good as well as for harm. Mr. Ham prophesied that the country would soon be out of the darkness of depression and in the daylight of prosperity.

Professor Whitehead said that a definition of salesmanship was the creation of additional business without additional expense. To create business is to sell something not thought of by the purchaser. He said that up to 1914 the country had salesmen, but since then they have become diplomats and with the cessation of the war the buyers' market also ceased. He deprecated the habit of cutting prices, in fact, he did not at all approve of ever talking prices when presenting an article. The real salesman never accepts a "no" for an answer; that word is the natural defense of a man who wants to know more about an article. Professor Whitehead's final word was that service should be the keynote of every salesman's activities; and he predicted that thirty days would see business very appreciably improved.

EASTERN SERVICE

"NEW ENGLAND SERVICE FOR NEW ENGLAND DEALERS"

HIS MASTER'S VOICE

"In Union there is strength."
We stand ready to unite with you in the merchandising of Victor products.

Eastern Talking Machine Co.
85 Essex Street
BOSTON MASS.

As a final tag to the evening the retiring president, George C. Mance, introduced Mr. Horning, the incoming president, and in response to a persistent demand for a speech Mr. Horning promised to give the association as good an administration as possible, and he asked that all the members give him their heartiest co-operation.

New Yorkers Entertain and Are Entertained

A very pleasant aftermath of the Association banquet was the entertainment, privately provided, for two of the artists who came over from New York, Messrs. Max Kortlander and Pete Wendling, piano players, who were here through the courtesy of the Q R S Music Co., and whose
(Continued on page 84)



VICTOR SERVICE PLUS

for

NEW YORK and NEW ENGLAND

We offer to the Victor Dealer co-operation that is intelligent, experienced and helps him get out of the rut, and put that "plus" business on his books, with two service centers that make for promptness in deliveries.

THAT'S DITSON SERVICE

OLIVER DITSON CO.
BOSTON

CHARLES H. DITSON & CO.
NEW YORK

THE TRADE IN BOSTON AND NEW ENGLAND—(Continued from page 83)

presence in large measure was due to the untiring efforts of A. J. Cullen, of the Lansing Sales Co. Following the dinner, in response to a request from a few of those who dallied behind, these two men generously sat down to the two Chickering baby grands and played a number of selections and then it was that George A. Dodge, of the Eastern Talking Machine Co., who is always hospitality itself, hit upon the happy idea of taking these young men out to his beautiful home in Brookline, meanwhile hurriedly getting together several others to enjoy the rest of the evening with them. The two New York artists returned home the next day with the firm conviction that there is some wonderful hospitality in Boston if one only gets in with the right people.

Covering New England Trade Territory

Fred E. Mann, manager of the local department of the Columbia Graphophone Co., is at this writing traveling through his New England territory. He left town a few days ago and ere he returns he will have visited the agencies in northern and western Massachusetts, New Hampshire, Vermont, Rhode Island and Connecticut. Business is reported as showing a splendid improvement and there have been a number of urgent calls from the representatives throughout the territory for good-sized stocks of merchandise that will carry them through the holidays.

New Columbia Agencies

The Columbia Co. of this city, through its wholesale headquarters, has just made some new connections in the field. One is G. Foster & Co., at Hartford, Conn., a large furniture company, which has taken on an exclusive Columbia agency. Another is the Farrar Furniture Co., of Bangor, Me., which has recently opened up an exclusive Columbia department in new quarters at 93-105 Main street, which is considered one of the best locations in the city. Miss Lillian Mason, of Bath, Me., is in charge. Miss Mason

HORTON-GALLO-CREAMER CO

NEW HAVEN  CONNECTICUT

VICTOR SERVICE SPECIALISTS

\$ \$ \$ \$ \$ \$

Helping the Victor Retailer
to make more of them is
part of our service.

has had a wide experience in the talking machine business. A third agency is Girari & Son, of Athol, Mass., which firm has been in business in the town for a number of years.

Retires From the Talking Machine Field

It will come as news to a number of Victor representatives in New England to learn that C. B. Estabrook, the traveling representative for

the Victor Co. has severed his relations not only with this company, but with the talking machine proposition in general, as he has decided to go into the automobile business and is to associate himself with the Walker-Johnson Co., dealer in auto trucks. He is to be attached to the Boston office. His new connection became operative November 1. Mr. Estabrook has been

KRAFT-BATES AND SPENCER INC.

NEW ENGLAND DISTRIBUTORS



PHONOGRAPHS AND RECORDS

The Chosen Phonograph of Professional Musicians

Until the advent of The Brunswick trained musicians had very little appreciation of the phonograph, but now their many outspoken endorsements of The Brunswick Phonograph and Brunswick Records show how their attitude has changed.

Most of them, when asked the reason for their preference, say that The Brunswick, more than any other phonograph, renders the *true tones* of the piano and other instruments, and gives the voice of the singer its fullest expression, without any *mechanical suggestion*.

KRAFT-BATES & SPENCER, Inc.
 1265 Boylston Street - - - Boston, Mass.

Steel Needles
NEW ENGLAND DISTRIBUTORS
Albums
Record Brushes
Khaki Covers



THE TRADE IN BOSTON AND NEW ENGLAND—(Continued from page 84)

a year and a half in the eastern New England territory for the Victor Co. and succeeded James Frye, who, it is rumored, may return to this territory.

Fitzgerald's Attractive New Home

A very conspicuous building in Cornhill, painted white from top to bottom, is now the home of Billy Fitzgerald, who has lately moved from the Studio Building, at the corner of Tremont and Bromfield streets, where his Victor headquarters had become widely known. Mr. Fitzgerald now has all the four floors and basement of 28 Cornhill, the interior of which is finished in white. There are a series of tastefully arranged demonstration booths on both sides of the ground floor. There's a large passing throng in Cornhill which should find this Victor headquarters a convenient place to do business. Mr. Fitzgerald has a big army of Boston friends who wish him the best of luck in his new location.

George Lincoln Parker in New Location

George Lincoln Parker, the Edison dealer, may now be found in a new location, for he has moved from the Colonial Building, in Boylston street, where his warerooms had been on the third floor for a number of years, and he is now at 144 Berkeley street, near Columbus avenue, on the south side, where he has a large ground floor. In the windows at each side of the entrance is a handsome Edison model, and several of these are grouped in artistic surroundings inside. In moving to this neighborhood Mr. Parker is a pioneer in getting into a location that is bound to attract retail business heavily sooner or later, because, for one thing alone, there is to be a large and costly hotel built in the next block very soon.

Miss Gertrude L. Hume Married

Miss Gertrude L. Hume, daughter of A. M. Hume, of the A. M. Hume Music Co., Victor distributor, was married toward the end of October to Howard C. Paul, the wedding taking place in the Universalist Church in Melrose, the

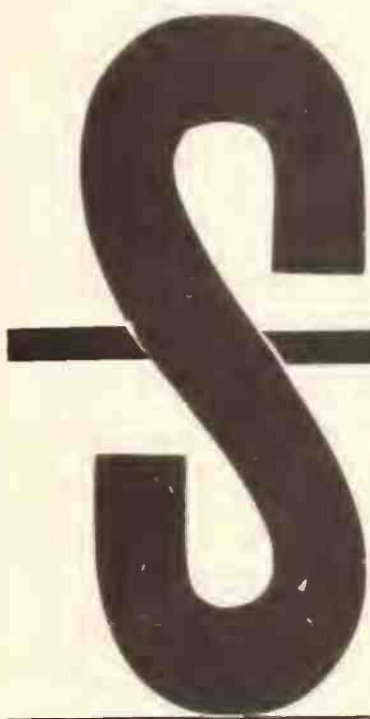

STEINERT SERVICE SERVES

Here are some of the salient features in Steinert Service:

- Educational and Personal Service Bureau.
- Practical Store Ideas Department.
- Promotion of Educational Work in Schools.
- Unsurpassed Record Stock.
- Efficient Back Order System.
- Excellent Shipping Facilities.
- Years of Experience in Victor Merchandising.

This is a part of our service. It is available to you anywhere in New England. We will be glad to help you in your Fall campaign.

AT YOUR COMMAND ANYWHERE IN NEW ENGLAND



M. STEINERT & SONS

Victor Wholesalers

35 Arch Street

BOSTON

bride's home city. Two clergymen took part in the ceremony. Mr. Paul and his bride will make their home in Melrose.

Tells of Rapidly Improving Business

Joe Burke, who is now an important factor in the Musical Sales & Equipment Co., Inc., says that business is picking up at a very rapid rate, and he looks for a good healthy business this

Fall and Winter. He has just received two new models of Sonoras, the Imperial and the Intermezzo, and he has placed a very large order for these, as already there is a demand for them, for they have the advantage of being well built and low priced. Mr. Burke has made several new connections throughout New England lately which look promising.

Edison Prize-winners Had Great Time

The five prize-winners in the successful Edison campaign undertaken by the Pardee-Ellenberger Co., Inc., as a means of stimulating business, returned home from their wonderful eight days' trip toward the end of October, and what they didn't have to say for the company and President Frederick H. Silliman wasn't in the dictionary. The competition for sales was entered into by 108 Edison dealers, who made reports to the Boston headquarters. There was to be one from each of the four territories handled by the company and, in addition, a fifth who was to be known as the winner of the lucky trip. The contest extended from August 5 to October 8. Those, therefore, privileged to leave Boston on Monday, October 17, were I. C. Trask, of Milford, Mass.; W. L. Perry, of the Johnston Co., of Fort Fairfield, Me.; A. D. Elster, of Meriden, Conn.; F. T. Knight, of the J. A. Foster Co., of Providence, R. I., and Otis Skinner, of the Otis Skinner Optical Co., of Bangor, Me. The trip included a visit to New York and to Orange, N. J., the home of Mr. Edison, where Mr. Maxwell introduced the prize-winners to the great wizard, each dealer receiving from Mr. Edison an autographed picture of himself; a visit to the famous Edison plant, including the Re-creation building. In the evening of the same day there was a dinner and show, which was tendered with the compliments of Thomas A. Edison, Inc. There was a trip up the Hudson, a visit to West Point, then the train was taken south and the famous Natural Bridge in Virginia and Louray Caverns were visited, and on the return a stop was made in Washington, where the guests met Senator Henry Cabot Lodge, Massachusetts' senior senator, who introduced them to President Harding. With the party was L. H. Ripley, the sales manager of the Pardee-Ellenberger Co., who acted as personal conductor. The company is in every way satisfied with the results of the sales campaign, and it proved conclusively that the

(Continued on page 86)

The "Perfection" Ball-Bearing Tone Arms

and

The "Perfection" Reproducers

For the New Edison



Excel in Clarity and Sweetness of Tone. Best quality of material and workmanship. Descriptive catalog, terms and discounts sent on request.

Manufactured by

NEW ENGLAND TALKING MACHINE CO.

16-18 Beach Street

Boston, Mass.

Factory Representative

L. A. SCHWARZ, Inc., 1265 Broadway, New York City

THE TRADE IN BOSTON AND NEW ENGLAND—(Continued from page 85)

business is there if only it is gone after. It is understood that President Silliman has in mind another campaign of a little different character to be conducted later.

Prepared for Strike, But Glad It's Passed

The trade in general is resting easy now that the possibilities of a railroad strike are waning into oblivion. There are few industries that had made greater preparations to meet the strike and if the railroads were not to be able to move goods there were the water routes to take advantage of and rather elaborate preparations had been made to get machines and records over by various styles of craft. It may be recalled that the Victor jobbers here, the Oliver Ditson Co. and the Eastern and Steinert houses, got a large consignment by water some fifteen months ago during an emergency and the same came along rather expeditiously, and consignments were quickly unloaded and distributed to the three concerns. Had the railroad strike come to fruition the same plan was to be carried out and pretty nearly every detail had been arranged for. But

the need for emergency measures now appears to be over and everybody is thankful that a menace to prosperity no longer exists.

May Have to Move Quarters

The Lansing Sales Co., Inc., has to look for other quarters immediately, for, according to the plans under way for the widening of Eliot street, where the company is now located, at the corner of Warrenton street, the building will soon have to come down; that is, it has been decided to demolish it rather than attempt to cut it off. A. J. Cullen, head of the concern, has his eye on a desirable location, for which he is now negotiating a lease.

News at the Steinert Headquarters

Wholesale Manager Kenneth E. Reed, of the R. Steinert & Sons Co., says that, despite persistent overtures to dealers to stock up as early as possible, he fears that there are going to be some who will dally so long as to deeply regret their inaction. The Steinert Arch street establishment has been getting large invoices of goods from the Victor factory, but it will not be long before the mountains of cases will disappear.

Mr. Reed says that the eight famous Victor artists are to give a concert on December 11 at Woonsocket, R. I., and he is interested in making some of the arrangements. The concert is to be given under the auspices of Laroe's Music Store. A concert given by these artists in that city before attracted a hall full of people. Mr. Reed says he had quite a party on the occasion of his (and his wife's) tenth wedding anniversary and there were many friends who remembered Mr. and Mrs. Reed very pleasantly.

Who Will Help Ambitious Young Inventor?

The World correspondent, the other day, ran across a young man who may be heard from yet in talking machine circles because of his inventions. His name is John Stephen, a Syrian, who lives in Dorchester, which is a part of Boston. He has invented a sound-reproducing and amplifying arm which, he says, will do away with the open box and the horn as now used in machines. While waiting for his answer from the United States patent office he is working on a machine which will do away with the winding arm, and the young man is confident that he will meet with success in this effort and soon have a machine that will wind itself automatically. During the day the boy, who is twenty years old, works as a mechanic and spends his evenings at his workshop in his attic perfecting his plans. Like many another young inventor, he suffers from lack of funds and every dollar he can save goes into his inventions. He is an ex-service man, having served with the Canadian Expeditionary forces.

Hough Specialties in Greater Demand

L. W. Hough, New England representative of Long cabinets and Peerless record albums, reports that conditions throughout the New England territory are not only good, but show a decided tendency toward the steady continuance of this good business. The volume of business transacted by Mr. Hough in these two accessories in the trade during the month of October, 1921, has eclipsed the business for the same period in 1920.

J. G. Widener Visits Branch Stores

J. G. Widener, president of Widener's, Inc., which operates a chain of fourteen stores, all of which are handling the Granby phonograph, made by the Granby Phonograph Corp., of Norfolk, Va., has just returned to his headquarters in this city, after visiting all the cities in which his stores are located. Mr. Widener reports that business is improving in a very satisfactory fashion everywhere.

Now, Can You Beat It?

During the recent No-accident Week in this State such slogans as "Beware" and "Watch Out" and "Take Great Care" and so on were everywhere conspicuous. Now, has this any bearing on the talking machine industry? Well, rather! Could you imagine a piece of music by the name of "Don't Get Hurt"? Listen:

During the No-accident period the proprietor of a talking machine shop in South Boston

The "Record" Is Broken



in sales of "Long Quality" cabinets and "Peerless" Albums in New England.

See both advertisements illustrated in this issue.

Send your orders for their lines to

L. W. HOUGH

Factory Representative

20 Sudbury Street Boston, Mass.

placed a "Don't Get Hurt" card in his window and underneath it another card bearing these words: "Buy Them Here for Seventy-nine Cents." A woman entered the shop and said to the clerk, "I'll take one of those records advertised in the window."

"Which records?" inquired the clerk.

"I mean the 'Don't Get Hurt' one," replied the woman. "It's a new one to me and I must have it."

The clerk grasped the situation and could scarcely refrain from smiling as he explained, haltingly, that he was all out of that record and tried to persuade her that he had others that she might like. But she couldn't be persuaded and said she'd call again when this particular one was in stock.

Makes an Assignment

The Phonograph Sales Co., of this city, has made an assignment for the benefit of its creditors to S. Max Abelson.

ORGANIZE MOTROLA SALES CO.

CLEVELAND, O., October 28.—The Motrola Sales Co. has been organized in this city under the direction of J. B. Tiffany, who will direct the distribution of the new Jones Motrola in the northern half of Ohio. The office, which is located at 1404 East Ninth street, has arranged facilities to take ample care of this device.

"The Music Without the Blur!"

This ideal of talking machine manufacture is attained more nearly than by any other, in the construction of the

MARVELOUS MAGNOLA
"Built by Tone Specialists"

"Magnola's Tone Deflector eliminates the scratch"



Watching the Music Come Out

We want to show you how to make money with MAGNOLA; and how MAGNOLA is the best buy on the Talking Machine Market to-day.

Send us your name and let us send you some real Talker Tips.

MAGNOLA TALKING MACHINE COMPANY

OTTO SCHULZ, President

General Offices 711 MILWAUKEE AVENUE CHICAGO Southern Wholesale Branch 1530 CANDLER BLDG. ATLANTA, GA.

LANSING KHAKI COVERS

The Pioneer Moving Cover



High Grade

Government Khaki

Dealer's Prices NOW:

\$6.00 medium size 43"x20"x23 1/2"

\$6.50 large size 49"x23"x24 3/4"

\$7.35 extra large 52"x22 1/2"x23 1/2"

Fitzall Leather or No. 3x Strap \$2.50

Piano Moving Covers \$18.00

SLIP AND RUBBER COVERS FOR PHONOGRAPHS AND PIANOS



Eliot and Warrenton Sts. BOSTON, 11, MASS.

Kerekjarto's versatile violin sweeps his admiring public to new heights of artistry and musicianship in his latest recording of Drdla's "Souvenir." Music-lovers are sure to want it for years to come. Columbia 79708.

**Columbia Graphophone Co.
NEW YORK**



MRS. M. MAX TOURING EUROPE

Wife of Manager of Gimbel Bros.' Talking Machine Department Presented With Brunswick Phonograph for Use While on Tour

Mrs. M. Max, wife of the manager of the talking machine and piano departments of Gimbel Bros., New York, sailed recently on the S. S. "Berengaria," which was formerly known as the "Imperator," for an extended trip through European countries. Mrs. Max is accompanied by her three children, for whom it will be an educational trip, as well as one of pleasure. Mrs. Max plans to spend a great part of the time in England and will also visit the leading cities of Belgium, Flanders and France.

On her departure Mrs. Max was presented with a Brunswick phonograph, together with a number of the latest Brunswick records, the gift of Edward Strauss, Eastern sales manager of the phonograph division of the Brunswick-Balke-Collender Co., for her use while on tour. According to present plans, Mrs. Max expects to return for the Christmas holidays.

HIGHER RATES ON FREIGHT

Higher rates on freight from the North and East to points in the lower Mississippi valley will go into effect on November 28, under a decision just rendered by the Interstate Commerce Commission on the application of Southern railroads for a revision of rates as a result of the elimination of water competition on the Mississippi and Tennessee rivers.

The Commission's decision provides for an increase estimated at 20 per cent on high-class merchandise traffic from Virginia to points in the lower Mississippi region, and stipulates that rates on other than first-class shipments are to be certain percentages of the first-class rates. This increase, although effective only from Virginia to the Mississippi, will be reflected in the freight rates from Philadelphia, New York, Boston and other Eastern points shipping to the lower Mississippi by all rail.

BOOT MUSIC CO. OPENS NEW STORE

The Boot Music Co., exclusive Victor dealer of Denver, Col., opened an attractive new store at 1622 Champa street, that city. This concern is one of the oldest in the State, having been organized more than forty years ago by W. A. Boot, who is still actively engaged in the business.

The Andre Mfg. Co., Inc., of Boston, has been incorporated with a capital of \$100,000, to handle phonographs and novelties.

COTTON FLOCKS

.. FOR ..

Record Manufacturing

**THE PECKHAM MFG. CO., 238 South Street
NEWARK, N. J.**

BIG FIELD FOR THE ELECTRICS

Seven Million Homes Equipped With Electricity Available for Talking Machines to Be Power-Controlled—Opportunity for Use of Motors

That a vast undeveloped field for the sale of electric talking machines exists in this country is made evident by figures recently made public by the National Electric Light Association. The Association states that there are approximately 7,000,000 homes equipped with electricity in the United States. It is estimated that there are in the neighborhood of 4,000,000 talking machines in the homes of the land. Of this number many are in homes unwired for electricity and of the machines owned by people having electricity in the home only a small percentage are operated by electrical current.

SIR HARRY LAUDER VISITS AMERICA

Sir Harry Lauder, famous interpreter of Scotch songs and Victor artist, has returned to the United States and is touring the principal cities between New York and Kansas City. Talking machine dealers in those cities in which this famous singing comedian will appear can make the visit one of profit to themselves by tying up their advertising with his appearance in their locality.

The N. E. Miller Co., of Danvers, Mass., has taken on the Vocalion line of machines and records.

NEW AUSTRALIAN TARIFF

Duty on Imports to Be Assessed on Home Market Price, Less Excise Tax

Provision has been made in the new Australian tariff for an alteration in the method of computing values on goods subject to ad valorem duties on which there has been paid in the United States an excise tax or an import duty, when the articles are for re-export to Australia, Mark Sheldon, Commissioner for the Commonwealth in New York, reports.

In the future the value for duty purposes will be determined by the fair market value for home consumption in the country of export at date of shipment to Australia, less the actual amount of excise duty paid thereon, according to the ruling.

This concession does not apply to goods on which the duty has been paid which have been incorporated into other goods.

SPIRITUALISTS MAKE FIRST RECORD

DETROIT, MICH., November 1.—The annual convention of the National Spiritualist Association, held here recently, was featured by the demonstration of what is considered to be the first spiritualistic record ever made. Gene Kenneth Lord, better known in spiritualistic circles as the "singing organist," is responsible for the record, which aroused considerable comment and is looked upon as a valuable medium toward further research along spiritualistic thought.

Your Problem Is Ours

**Good Profits (to you)
-|- Good Service (to your customers)**

Answer: TONAR RECORD BRUSHES

(Trade Mark)



Have we solved the above problem correctly?

Write to-day for prices and sample and see for yourself

Made in mahogany, oak and ebony colored finishes

PARKS & PARKS, Inc.

TROY, N. Y.

New York Office, C. E. Peabody & Co., 186 Greenwich St.

MOTROLA

The NEW

with
Universal Motor \$19⁵⁰
 Retail Price

A saving of \$10.50 from the former
 price, \$30.00

The *New Motrola* does not replace the spring motor or change any part of the talking machine or phonograph, except winding arrangement, and is quickly and easily attached to any and every make instrument where the old-style crank handle comes out.

It is a universal motor operating on all electric currents 105 to 125 volts. Special types are made for 32 volt farm lighting current and 200 to 250 volts.

Through our new method of distribution all dealers are now assured of prompt and efficient service from our local jobbers. Don't delay. Write your nearest distributor today for full details and trade discounts on this wonderful proposition:

Distributors for State of Illinois
RUDOLPH WURLITZER CO.,
 Chicago.

BRUNSWICK-BALKE-COLLENDER CO.,
 Chicago.

COLE & DUNAS MUSIC CO.,
 Chicago.

H. A. WEYMANN & SON,
 Philadelphia, Pa.
 Exclusive distributor for Eastern Pennsylvania, Southern New Jersey and Northern Delaware.

BUEHN PHONOGRAPH CO.,
 Pittsburgh, Pa.
 Exclusive distributor for Western Pennsylvania, Eastern Ohio and Edison Dealers in West Virginia.

MOTROLA SALES CO. OF NORTHERN OHIO,
 Cleveland, Ohio.
 Exclusive distributor for Northern Ohio.

Distributors for Greater New York
CHARLES H. DITSON & CO.,
 New York City.

SILAS E. PEARSALL CO.,
 New York City.

BLACKMAN TALKING MACHINE CO.,
 New York City.

CABINET & ACCESSORIES CO.,
 New York City.

KNICKERBOCKER TALKING MACHINE CO.,
 New York City.

GREATER CITY PHONOGRAPH CO.,
 New York City.

INTERSTATE SALES CO.,
 Milwaukee, Wis.

BADGER TALKING MACHINE CO.,
 Milwaukee, Wis.
 Exclusive distributors for Wisconsin.

KRAFT, BATES & SPENCER,
 Boston, Mass.
 Exclusive distributors for New England States.

COHEN & HUGHES,
 Baltimore, Md., and Washington, D. C.
 Exclusive distributors for Maryland, District of Columbia, Virginia, North Carolina, Southern Delaware and West Virginia.

BUFFALO TALKING MACHINE CO.,
 Buffalo, N. Y.
 Exclusive distributor for Western New York.

STEWART TALKING MACHINE CO.,
 Indianapolis, Ind.
 Exclusive distributor for Indiana.

PERRY B. WHITSIT CO.,
 Columbus, Ohio.
 Exclusive distributor for Central Ohio.

LOUIS A. SCHWARZ, exclusive factory representative for the
 United States and Canada

JONES-MOTROLA, Inc.

29 West 35th Street

New York City

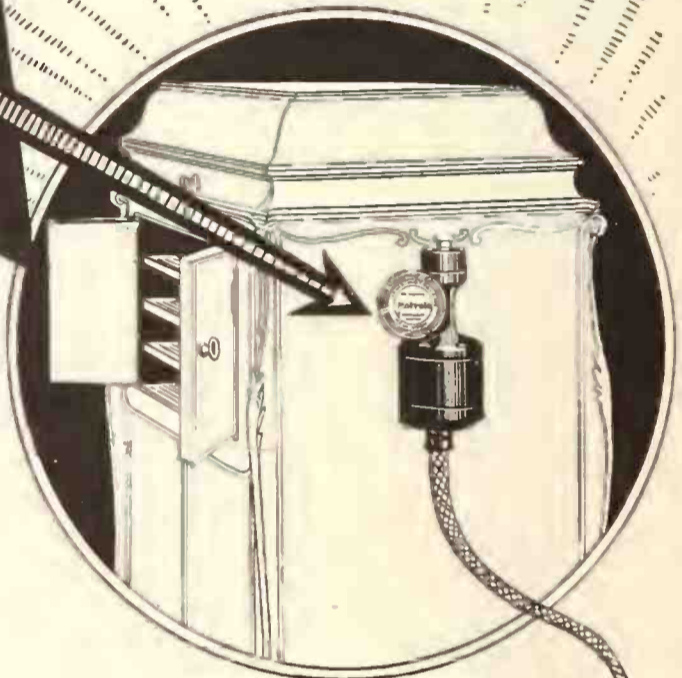

APPOINTED EXCLUSIVE JOBBER

Greater City Phonograph Co. Now Exclusive Sonora Jobber in Local Territory—New Salesmen Added to Staff of This House

The Greater City Phonograph Co., 311 Sixth avenue, New York, which was appointed a Sonora jobber a few months ago, is now the exclusive jobber for Sonora products in this territory, the Sonora Phonograph Co. having discontinued its local wholesale branch. The territory controlled by the Greater City Phonograph Co. consists of the Borough of Manhattan in New York City and the Greater New York territory as far north as Poughkeepsie, together with Staten Island.

In order to give Sonora dealers in this territory maximum service, Maurice Landay, president of the Greater City Phonograph Co., has increased the sales staff by the addition of Kenneth R. Perkins and David Danziger, who were formerly connected with the Sonora Phonograph Co.

In a chat with The World Mr. Landay stated that his company's business was steadily growing, and that the sales totals for the month of October were far beyond expectations. The Greater City Phonograph Co. was recently appointed a jobber for the Jones-Motrola, and has started an aggressive campaign in behalf of this popular accessory.

MAX STRAUSS ARRIVES HERE

Managing Director of Carl Lindstrom, Ltd., Berlin, Arrives for Extended Visit—Will Study Various Trade Phases in This Country

Max Strauss, managing director of Carl Lindstrom, Ltd., Berlin, Germany, arrived recently in New York for an extended trip through the United States and Canada. Mr. Strauss intends to make a thorough observation of the methods employed by the leading manufacturers in the distribution of their product and he also plans to spend considerable time with the retail dealer in order to study the methods used in serving the talking machine and record customer. While in this country Mr. Strauss will make his headquarters with the American Odeon Co., 100 West Twenty-first street, New York, and will confer with the officials of this company on matters pertaining to the wider distribution of Odeon records in this country.

SALES TO PROMINENT ST. LOUISIANS

Sonora Sold to Well-known Musician of St. Louis—Other Interesting Sales

St. Louis, Mo., November 7.—The Eastern Star Lodge of Missouri recently determined to present their Grand Matron, Mrs. Zoe Brooks Holman, with a phonograph as a mark of their esteem. The decision as to the make of instrument to be purchased was left to a committee of six, the members of which were instructed to hear and see all of the standard phonographs and make a definite selection.

After testing and hearing many of the leading machines on the market, the committee selected a Sonora Nocturne in brown mahogany and presented this instrument to Mrs. Holman, who was delighted with its attractiveness and tone quality.

Another recent sale of more than passing interest was that of a Sonora to Frank Gecks, president of the Musicians' Union of St. Louis and one of the leading violinists of the St. Louis Symphony Orchestra. The instrument, a Sonora "Elite," was sold by F. Beyer & Son, of this city, after Mr. Gecks had made an extensive investigation as to the machine that he desired.

FILE PETITION IN BANKRUPTCY

The Phonograph Protective Service Co., a retail talking machine business operated by Louis W. Nugent, at 636 Second avenue, New York, has filed a petition in bankruptcy, listing liabilities of \$1,310 and assets of \$695.

A SALES-BOOSTING IDEA

Dealer Awards Prizes to Children Obtaining Information of Old Talking Machines—Data Furnish Basis for Sales Campaign

An extremely clever plan which was recently worked out by a talking machine dealer not only resulted in the gathering of considerable valuable information on the machines owned in his community but also resulted in the sale of a number of new machines. The plan follows:

Several prizes were offered to the boys and girls for giving him reports on the oldest talking machines in town, those in actual use. Each boy and girl filled out a slip for each one, the name and address of the owner, the name of the machine, the date of purchase, and from whom it was bought.

The prizes were awarded to the boys and girls who sent in reports on the oldest machines in actual use. From these reports the dealer had excellent information for a selling campaign. With a series of letters, followed up with personal calls, he sold a larger number of new

talking machines in the next sixty days than he ever sold before in a whole year. The reports showed him just who his prospects were and he was able to go after them intelligently.

RUDD & RIX OPEN HERKIMER BRANCH

HERKIMER, N. Y., November 2.—Rudd & Rix, Iliion, N. Y., music merchants, opened a branch store in the Herkimer National Bank building here this week with a complete line of Victrolas, records and musical supplies. The establishment has been entirely redecorated to meet the demands of the business and now presents a most attractive appearance. Robert Bothwell, who has charge of the Iliion store, is also manager of the local establishment.

SELLS PERIOD MODEL VICTROLA

A. Lesser, Victor dealer, of 631 Sutter avenue, Brooklyn, N. Y., recently sold to one of his regular customers, Felix Elbaum, a successful merchant of Jamaica, L. I., one of the period model Victrolas, priced at \$1,200.

HERE IT IS!!

The Feature Model—The Big Profit-Maker

RETAILS at \$100.00

Look It Over—Quality Throughout—At a Price That Sells

Open it up and put it in your window and watch the sales roll in

**New
Charmaphone
Model
No. 9**

—

*Write for
Catalog and
Particulars*



**Equipped with
Heineman No. 33
Double Spring
Motor—Plays
Five Records**

**Height 47 in.
Depth 23 in.
Width 19 in.**

**Large Tone Arm
Plays All
Records**

CHARMAPHONE COMPANY

39 West 32nd St., New York City **Factory: Pulaski, N. Y.**

GREAT ACTIVITY EVIDENT IN THE CLEVELAND TRADE

Many New Dealers Enter the Field and Established Houses Open New Departments or Extend Their Lines—First "Victrola Show" Held—Recent Changes Among the Wholesale Houses

CLEVELAND, O., November 9.—The first Victrola Show for Cleveland, probably for the country, was held during October, under the auspices of Wm. Taylor Son & Co., this city. The event was planned by T. A. Davies, manager of the talking machine department. Old machines, some of the original vintage of the Victor, were shown. Pictures of celebrities in the talking machine world and of the original factory of the Victor likewise were displayed. The old machines, beside the most modern period models, offered a significant contrast to visitors. The show proper was held in a temporary arcade made of velvet



View of First "Victrola Show"

hangings, which was decorated with palms, flowers and lamps and oriental rugs. In all, about 200 machines were used in the ensemble. The five main windows of the Taylor store were used for several days, each showing three Victrolas, being among the most attractive windows ever seen in this city. The show brought many visitors, augmented the list of prospects and, most important, resulted in much real business during the event, according to Manager Davies.

Columbia National Publicity Campaign

Plans for taking up the Columbia Co.'s national publicity campaign as it will apply to the Cleveland branch territory have been completed by Branch Manager S. S. Larmon. The advertising will be used in one paper in each of eight cities in this vicinity. In Cleveland alone thirty dealers will benefit by the publicity that will bring them closer to the public.

Special Record Service for Teachers

The Cleveland branch of the Columbia Co. is completing arrangements for the demonstration of records to all school teachers in the district,

these to be held in the Columbia Co.'s model shop here. About fifty school supervisors have been advised of the service and dealers have been urged to hold themselves in readiness to serve teachers who will have made their record selections at headquarters. The scope of this work may be estimated by the fact that in Cleveland alone there are one hundred schools.

Jack Kennedy's Handsome Department

One of the best indications of progress in the industry in these parts is the large number of new establishments and the plans for extending operations by others. One of the most pretentious moves is that by Jack Kennedy, for the last three years traveling representative for the Cleveland branch of the Brunswick-Balke-Collender Co., and prior to that in similar capacity for the Eclipse Musical Co. Mr. Kennedy has organized a new retail talking machine firm and will open in the store of the Vincent-Barstov Co., large downtown furniture establishment, close to Euclid and East Ninth streets. Here six booths have been erected and probably as many more will be installed at a later date. Complete talking machine windows will be a feature and windows in which the talking machine is used in living-room furniture displays will be created. A considerable space for display purposes and salesroom on the ground floor of the Vincent-Barstov Co. has been taken.

Again to Handle Victor Line

The Collister & Sayle Co. adds another downtown Victor establishment to the list. This move is new and again it is not, since this firm was for years a Victor retailer, but temporarily withdrew to push the sale of sporting goods. A better talking machine department will be created on the first floor and, perhaps later, the department will be extended to the second floor. Miss Hallie Snyder will be department manager and Ernie Rezeau, general manager, will have supervision of this business.

Two New Meier Branches

Official openings of two new branch stores are being planned by the L. Meier & Sons Co. These stores are at Lorain and West Ninety-seventh streets and West Twenty-fifth and Archwood streets. Both are duplicates of the unique and handsome original establishment of the Meier Co. at Clark and West Forty-first streets. In fact, it has been equipped in even more elaborate manner. Mrs. Loretta B. Flading, well known in

retail talking machine circles here, has been appointed manager of the Lorain location and Miss Leona Horn will be in charge at West Twenty-fifth street.

Dealers Take on New Lines

In planning expansion the move of the Euclid Music Co. is important. The firm has added the Cheney and Brunswick phonographs to its Victor line and will feature the new additions in all three stores. The Alhambra Music Co., which has been noted for its Columbia exploits, also will push the Brunswick.

New Cheney Dealers

Numerous new dealers have been added by the Cheney Phonograph Sales Co. in the last few weeks. In Cleveland the line will be taken by the Home Piano Co. and the Gordon Square Music Co. New dealers elsewhere in Ohio include J. C. Evans & Co., Ridgeway; Spear Music Co., Dover; J. Y. Jackson, New Philadelphia; C. M. Stevenson Piano Co., Hamilton. Still others are Fields Furniture Co., Ashland, Ky.; D. E. Shaw, Grafton, W. Va.; Morgantown Music Co., Morgantown, W. Va.

Some Important Changes

Several important changes in the industry in this section have occurred during the period. The Kennedy-Green Co., Okeh record wholesaler, has been taken over by the Kennedy-Schultz Co.; the Fischer Co. resigns as Pathé distributor in Ohio, and new executives take charge in other establishments.

Kennedy-Schultz Co. Developments

In adding the Kennedy-Green Co.'s business to its own the Kennedy-Schultz Co., as Granby phonograph distributors in Northern Ohio, acquires an important adjunct. Samuel Green, head of the Kennedy-Green Co., retires to attend to other investments. The Kennedy-Schultz Co., recently incorporated, and headed by C. H. Kennedy and H. C. Schultz, talking machine men of long experience, will have headquarters at 1863 Prospect avenue, where a three-floor building is being altered and improved for machine and record demonstration, display and sales purposes. Samuel Merkin, with the Columbia Co. eighteen years, will be connected with the firm and R. P. Treat will be office manager.

New Managers Take Charge

Two new executives assumed management here during the month. Edward B. Lyons took charge as general manager of the Eclipse Musical Co., Victor jobber. Plans for reorganization and sales promotion will be announced in a short time. S. S. Larmon, formerly special representative in the Detroit territory for the Columbia Graphophone Co., arrived to become manager of the Cleveland branch of this company. Mr. Larmon already has covered a goodly part of the Cleveland territory and, though improvement already is noted in business, expects to be able to announce plans that will make it still better shortly. Cleveland headquarters wholesalers are working consistently with dealers, preparing the way for holiday business.

Going After Columbia Business

A special drive for C. G. Ober, Chagrin Falls, has been put on by Dan Des Foldes, of the Columbia Cleveland staff, and many instruments put into homes during the campaign have remained there. At the Ober establishment Miss Marjorie Whitten, record sales manager, also gives music lessons on piano and other instruments, an innovation in music store management. The fairs will be productive of likely holiday prospects, in the opinion of E. F. Hughes, Columbia branch service manager, following the gathering of a large list at Coshocton, where an unusual booth and campaign were conducted for B. W. Klein. More than 100 prospects were obtained and a big mailing list secured. Similarly good results were obtained for the Fountain Co., at the Coshocton Fair, by E. M. Scott, of the Cleveland branch Brunswick establishment. The Fountain booth was one of the most elaborate at the fair.

Some Interesting Brieflets

An unusual window display has been that of the Buescher Co., to illustrate the "Song of India." A small stage was built, showing a scene in an Indian city—mosque, minarets and



Quality

Mr. Jobber and Mr. Dealer, the Lone-Star Phonograph has gained in public favor. Sales of Lone-Star Phonographs have been excellent during the entire year of 1921.

We are giving our Dealers the best dealership proposition of any concern in the industry.

Mr. Dealer, it is worth your while to investigate the Lone-Star Franchise in your Territory.

Texas Talking Machine Company :: DALLAS, TEXAS
Service

turbaned natives. Several elephants, with howdahs and mahouts, march across the stage, while a Victrola plays the air.

Miss Ethel M. Volk, for a decade connected with the talking machine trade here and elsewhere, has resigned from the Cleveland Talking Machine Co. Miss Volk and Fred Koeckert, of New York, were married at Galion.

A portable alcove, heavily curtained, in which a phonograph is displayed, is a new window attraction being used by the Cheney Phonograph Sales Co. for dealers here. The Muehlhauser Bros. Piano Co. was the first to use this attraction and added several sales, according to Secretary Buel, of the Cheney Co., thereby. The Young Furniture Co., the University Music Co. and others in Cleveland will have the device later.

Mrs. R. M. Smith, noted musician, of Springfield, O., has been appointed service director of the Cheney Phonograph Sales Co. and will cover Ohio and adjoining territory in the interest of dealers.

A Business-building Stunt

A unique business builder for dealers was tried out, and successfully, by the Kennedy-Schultz Co., Granby distributor, at the Olympic Theatre; co-operating was the Miltner Music Co., located in the same building. A stage setting, duplicating the French window curtained effect seen on most Granby literature, was used, with a real Granby. E. W. Windsor, of the Kennedy-Schultz, made a brief announcement and then played two selections from a record made by Tom Mix, movie actor. The event was linked with the showing of a Tom Mix picture. More than 2,500 persons saw the Granby and heard the record under these favorable conditions.

Some Effective Publicity

Listings of artists appearing in concert and of music being played in motion picture theatres will be made up in new bulletin form, to be used by dealers as window displays. The bulletins are being prepared by the Cleveland Talking Machine Co. Similar publicity is being prepared by Miss Grazella Puliver, publicity director, for the pushing of dance record sales. In

addition, information explaining the story of each dance record will be prepared, which dealers can send out with their regular information to clients.

Realize on Nora Bayes' Appearance

A new method for co-operation between the theatre and the talking machine industry has been used during the last week or so in connection with the personal appearance of Miss Nora Bayes, Columbia record maker, at the Shubert Opera House, vaudeville theatre. A Columbia instrument, with Nora Bayes' records, was installed in the lobby of the theatre and played constantly before the arrival of the star and during her appearance at the Shubert. The details were carried out by E. F. Hughes, service manager at the Columbia Cleveland branch. Increased attendance at the theatre was reported by the theatre management. Large sales of Nora Bayes' records also were accomplished for dealers, as special sales were arranged, with suitable window displays, as well as a big variety of these particular records.

Model Shop for School Teachers

Service for school teachers and others seeking the selection of records in educational work has been started at the Columbia Cleveland branch, where, in the model shop, many teachers are now gathering every Saturday to hear the records, making their purchases later at the dealers near where the teachers live or conduct their classes. Helpful suggestions are offered by H. C. Cooley, assistant branch manager, and the staff at the Columbia branch, which are appreciated by the teachers.

A New Selling Plan

Salesmen are covering the Alliance district for J. H. Johnson's Sons, selling \$1 certificates, which are applicable to purchases of Granby phonographs before Christmas.

New Columbia Accounts

Considerable new business is being booked personally by S. S. Larmon, Columbia branch manager in the Cleveland district, several new accounts being added in the territory, while older Columbia dealers are adding steadily to their machine and record stocks.

J. M. Megrit, formerly service manager of the Detroit Columbia branch, has been appointed to a position on the sales staff in the Cleveland district by Branch Manager Larmon.

Christian Science Hymns Big Sellers

Arrival of several of the new Christian Science hymn records of Thomas A. Edison, Inc., at the Phonograph Co., Edison wholesaler, has started a campaign for developing this part of the business. Several sales have been completed, according to Harry R. Tucker, and still better results are anticipated with the receipt of more of these particular records.

Public Invited to New Home

Invitations to the trade to visit the new home of the Kennedy-Schultz Co., Prospect avenue and East Nineteenth street, were being sent out, following the completion of the interior of this establishment. A color scheme of gray has been followed throughout in the display rooms and these are equipped with wicker furniture, rugs and draperies and lighted with floor lamps, making a pleasing background for the demonstration of Granby phonographs. The second floor has been completed for an efficient Okeh record stockroom.

Mamie Smith Entertains

During the appearance here of Mamie Smith, Okeh record maker and popular entertainer with the colored folk of the entire country, the Kennedy-Schultz Co. linked up her entertainment here with dealers and large numbers of records were sold. Streamers for all Okeh record dealers' windows were provided and several dealers used the regulation theatrical billboards in front of their stores. Miss Smith was brought to Cleveland by influential colored citizens and sang at the Prospect Theatre and at a dance at Dreamland ballroom.

A. Thalmayer, record department manager of the General Phonograph Corp., was a visitor at the Kennedy-Schultz Co. lately and promised that the record made by Kiraly Erno, popular Hungarian tenor, soon will be released. Erno is an idol of the Hungarian people here and was well received during his personal appearance in northern Ohio some time back.



Let us send you details of our Okeh Record Agency.

The proposition has a direct appeal to any progressive dealer.

The Okeh Record sells fast. Why not fill your shelves now and enjoy the benefit of the enormous holiday profits.

STERLING ROLL and RECORD CO.

Pittsburgh, Pa., 436 4th Ave.

Cincinnati, Ohio, 137 W. 4th St.

H.K. Lorentzen

Manufacturer of

Exclusive Cabinet Hardware and Accessories

60 Grand Street

New York City

EXHIBITS AT WHITE PLAINS FAIR

Hunt's Leading Music House of That City Attracts Much Attention With Fine Display

Practically every representative merchant in White Plains, N. Y., had a booth for the display of his line at the White Plains Exhibition, held at the State Armory in that city recently, under the auspices of the local Chamber of Commerce.

Among the most elaborate of the displays was that of Hunt's Leading Music House, Inc. The exhibit included a full line of grands, uprights, players, Q R S player rolls, and an extensive ar-

ray of Victrolas, including one handsome Period model. A considerable number of the company's staff were in attendance, including John L. Hunt, president, and A. L. Yaeger, secretary-treasurer.

Musical entertainment was provided as a part of this exhibit, a feature of which was solo singing by Miss Marion Lowell, a talented resident of White Plains, whose work has met with considerable favor in New York City.

There was also a very attractive exhibit consisting of about seven floor model Columbia Grafonolas, exhibited by the White Plains Furniture Co., with L. Rhinauer in charge.

On the evening on which a member of The

World staff attended there were over 4,000 people present and the exposition accomplished much in the way of stimulating the public to buy. White Plains has a population of about 22,000, and it would seem as if the example its Chamber of Commerce has set could be followed most advantageously by other cities.

PREVENTING FROSTED WINDOWS

Two Methods of Preventing Windows From Becoming Covered With Frost

Talking machine dealers, in common with other merchants, suffer during the Winter months from frosted windows. No matter how effective the display of machines and records may be, it becomes valueless as soon as it is hidden from view, and frost effectually accomplishes this, to the great detriment of sales. In this season the air in the display windows must be cooled and warm air from the interior of the store prevented from circulating against the glass.

This can be accomplished by boarding the inside of the windows or have tight-fitting sashes to prevent the warmer air of the store striking the panes. Next bore a row of holes at the base of the window and a similar set at the top. This will permit a free flow of air and keep the temperature down.

A simpler method is to use an electric fan. Start the fan running first thing in the morning and keep it running all day. This keeps the warm air on the move and lowers the temperature so frost will not have a chance to collect. The sight of an electric fan working in Winter also will help to attract attention to the window.

BURGLARS IGNORED REMINGTON

James S. Holmes, vice-president, and Everett Holmes, general sales manager, of the Remington Phonograph Corp., have been exceedingly busy within the last few months directing the increased business that the company is receiving. Accordingly, they found it necessary to visit the offices of the corporation at 1662 to 1666 Broadway one recent Sunday to clean up some details which during the ordinary course of the business day had escaped them. Upon reaching the offices they were astonished to find a hole about three feet square cut in the floor directly in front of the safe. It seems that burglars had carried off a large quantity of expensive furs from a retailer directly beneath the offices of the Remington Phonograph Corp. and had used the Remington offices as a means of entrance. Fortunately, not even a postage stamp was touched at the headquarters of the Remington. We are surprised the daily paper reporters did not use their imagination and have the burglary occur to musical accompaniment. Great opportunity lost!

MAKE STORE MORE ATTRACTIVE

NEWARK, N. J., November 8.—Alterations which have been under way at the establishment of the Griffith Piano Co., Sonora distributor for Newark and vicinity, will, when completed, greatly enhance the attractiveness of the store and furnish greater opportunities for the display of Sonora machines. The walls have already been decorated in old ivory and further improvements include new lighting installation and elaborate window decorations during the holiday period.

If a salesman is master of himself it's dollars to doughnuts that he can master his job successfully.



Trying to cut down expenses

New business conditions have forced every merchant to face the problem of reducing expenses.

Thousands of merchants have solved the problem by using new model National Cash Registers.

These cash registers reduce costs of selling, delivery, and bookkeeping. They stop expensive leaks and losses. They also point the way to other economies by giving merchants, every day,

necessary business facts

- ① Sales made by each clerk.
- ② How goods are moving in each department.
- ③ Amount of capital tied up in outstanding accounts.
- ④ Volume and profit on credit business compared with volume and profit on cash business.
- ⑤ Total of money paid out.

These facts show how, when, where, and how much to reduce expenses.

A National Cash Register is the only machine that issues a receipt, indicates, adds, prints, classifies, and distributes records at the time of the sale, all in one operation. No figure work. No delays. No mistakes. Just read the totals.

National Cash Registers now priced as low as \$75 in U. S. A.

They pay for themselves out of part of what they save.

NATIONAL
CASH REGISTER COMPANY - DAYTON - OHIO

The Trade in PHILADELPHIA and LOCALITY

PHILADELPHIA, PA., November 7.—The talking machine business in Philadelphia during the month of October was more or less satisfactory. It found the people still susceptible to music, but, strange as it may seem, it did not increase over previous months of the year in the same ratio of percentage as did the piano business, and dealers have been unable to account for this. It remains, at this writing, one of the unsolved mysteries of the trade. A change for the better is looked for.

During the month the talking machine business here has been dwindling somewhat in the number of machines that are being handled, and firms seem to have had the experience that to push a certain few machines that are priced in good variety is better than to have a long list of them of practically the same price, which is more or less confusing to the salesman and customer as well.

Brunswick Demand Expands

The new Brunswick manager here, Richard M. Nelson, reports that the month was most satisfactory for the company he represents, although the past week has been a little spotty in character in the local market, but the Brunswick demand in the coal regions has been especially good. Mr. Nelson is keeping the wires busy in trying to speed up shipments, and says he is oversold four to one on the new models. The reason for this is that there was an immediate demand all along the line for these new models and, consequently, the firm has been swamped.

One of the interesting pieces of news of the Brunswick Co. of the month is that it has installed a Dealers' Service department in connection with its work, which has been placed in charge of Miss McGowen, who was with the

Columbia Co. for more than five years and is quite well equipped for this undertaking.

New Brunswick Agencies

Recently the Brunswick Co. opened a new shop, to be known as the Brunswick Music Hall, at 221 Lackawanna avenue, Scranton, and reports are that it has already done a very flattering business. The place was formerly known as the Venetian Music Co. Large advertisements have been run in the Scranton papers. Besides this house the Brunswick Co. has also placed its machines in the stores of Leivy & Sons, Danville, Pa.; L. C. Boardman, of Audubon, N. J.; the Sheffer Furniture Co., of Reading, Pa.; J. Rosenfield, of Burlington, N. J., and Harry Mosier, of Norristown, Pa.

Among Mr. Nelson's visitors during the month were: E. L. Gramlich, the supervisor of the Brunswick branches; Robert Bensinger, a son of the president of the Brunswick Co.; P. L. Deutsch, the assistant secretary of the company, and Edward Strauss, the sales manager of the phonograph division of New York. The firm is arranging for a concert of Brunswick artists in the near future.

Weymann Tells of Trade Progress

H. A. Weymann & Son note that there has been a decided improvement in their phonograph department during the month. Harry Weymann says: "The month of October showed a decided improvement, both in the sales of Victrolas and records. We are keeping in close touch with our dealers and are making daily deliveries of special finishes in Victrolas. We anticipated some time ago that it would be of great advantage to our dealers to be in a position to take care of their immediate wants. Mahogany finishes are being shipped out to all of our dealers, in all styles,

who have placed advance orders with us."

A Satisfactory Columbia Month

The month of October was a very good one with the Columbia distributors and dealers here. During the last week of the month there was a very fine Columbia exhibit at the Household Appliance Exposition at the First Regiment Armory. The following Columbia dealers promoted this display: Lightbown's Music House, 6403 Woodland avenue; O'Halloran's, 7 South Sixtieth street; Falls Hardware Co., J. E. Williams, 1703 Snyder avenue, and the Frankford Music Shop. The Columbia booth was nicely decorated and along the entire top in a fine electric sign it stated "Say It With Music." All standard models were on display, including several period models, and all the best of the latest Columbia records were also displayed.

C. A. Oschman, who has been with the Columbia Co. for some time, has just resigned as salesman, but has not announced his future plans. P. C. Cummin, the Philadelphia manager, spent considerable time during the month among the dealers up the State.

Among the Columbia visitors during the month were Mr. Sweatley, of Thompson & Sweatley, Soudertown, Pa.; Mr. Diefenderfer, Reading, Pa.; Calver Anderson, Wilmington, Del., and Mr. Newkirk, of Salem, N. J.

New Columbia Dealers Appointed

Among the new Columbia dealers announced during the month in this section were: The Royal Music Shop, 880 North Seventh street; the Thirty-fourth War Music Shop, 404 North Sixty-fourth street, and E. A. Goldman, Inc., 623 South street. Mr. Goldman took over the entire business of Max Klaidman, and it is one of the

(Continued on page 94)

STRENGTH IN THE VICTOR INDUSTRY

Insuring Growth, Profits and Stability

Victor Victrolas and Records are supreme.

The Victor Talking Machine Company is an ever developing and aspiring organization for continued commercial and artistic leadership.

Victor Retail Representation should tie up with Exclusive Wholesale Victor Jobbers whose purpose is strong and commercial ideals high, one to whom they can go, not only for merchandise, but also for constructive sales developing help.

The Louis Buehn Company
of Philadelphia

THE TRADE IN PHILADELPHIA AND LOCALITY—(Continued from page 93)

largest stores in the southern section of the city. He expects to conduct an exclusive Grafonola Shop. His place is a copy of the Columbia model shop and is one of the finest talking machine establishments in this city.

Big Advertising Campaign Now Under Way

The Columbia Co. is now conducting a big advertising campaign here which will be continued until the first of the new year. The campaign began October 14, with one-half-page advertisements in all the Philadelphia morning and evening papers, and the dealers report that it has greatly increased their business. At the bottom of each ad are listed the names of the leading Philadelphia dealers. The dealers throughout the city have been co-operating in this campaign by a distribution of circulars in the zones controlled by their respective stores. The company is sincerely trusting that its supplies will permit it to furnish dealers with enough merchandise to take care of the anticipated increased business.

Double Record Rack Space

The Penn Phonograph Co. is engaged at present in adding practically double the amount of record rack space to its department at 913 Arch street and has been getting heavy shipments from the Victor factory. It reports that it had a very satisfactory business all through October and that everything points to a good holiday business. Dealers have begun to buy in larger quantities than they did several months ago and are stocking up Victor machines and records anticipating their Christmas requirements and they feel very optimistic.

A New Arrival

E. Caruso has arrived in Philadelphia in a newly named talking machine that is made by the N. Mack Co., of 834 South Forty-ninth street. The Master Music Co., at 129 South Eleventh street, has one of the \$150 models in its window. It is a good-looking instrument.

Blake & Burkart Progress

Blake & Burkart, on the whole, had the best month of the year in October. It was good from the start of the month and in their October business they did not run very far behind October of last year. They also note that their record business has been picking up.

The Penn Dogs Have Their Say

The Penn Co., during the month, issued a rather interesting circular regarding its Penn Victor dogs, showing that more than 500,000 of

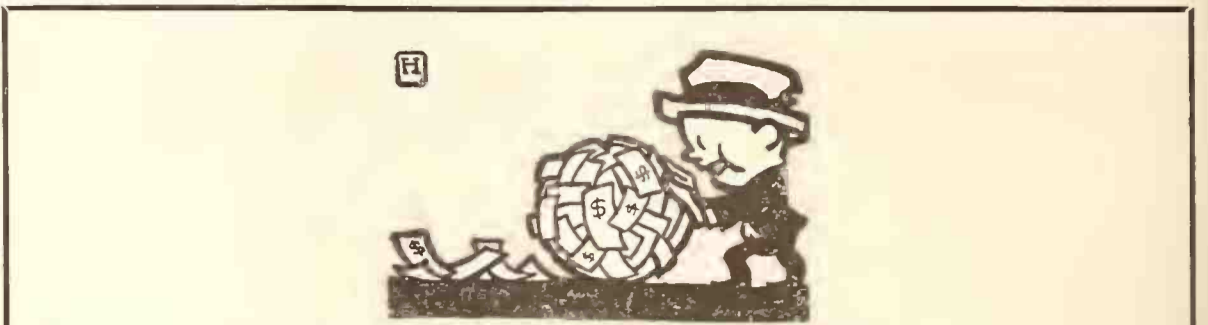

“ROLL YOUR OWN”

ASK ANY OF OUR OKEH
DEALERS—THEY KNOW

Okeh Records
ARE PROFIT MAKERS BECAUSE
“THEY SATISFY”

SONORA
COMPANY OF PHILADELPHIA

1214 ARCH STREET

PHILADELPHIA

these dogs have already been sold, and if they were placed side by side they would make a line fifteen miles long. In the circular is a letter purported to have been written by one of the dogs, one paragraph of which is especially worth quoting: “I have traveled in all parts of the world and was cordially received everywhere. Wherever a Victor dealer has advertised my coming and his desire to place me in the homes of his town people have flocked to his store to receive me.”

Recently Mr. and Mrs. T. W. Barnhill motored to Chambersburg, Pa., to visit their daughter, who is at a boarding school there. While there Mr. Barnhill called on the local Victor dealer, F. Hayes Harmon.

Edison Artists Heard in Concert

A number of Edison artists were heard in a concert in the phonograph department of N.

Snellenburg & Co. on November 3. They included Miss Leeta Corder, soprano; Robert Veltton, violinist, and Leslie Loth, pianist. E. W. Eisenhart, the phonograph manager, was somewhat disturbed on account of his being compelled to congest his department at this busy period to make room for these concerts, although he is still of the opinion that this is not “a one-horse town.”

Installs New Hearing Rooms

Charles C. Martin, a Victor dealer in Darby, who has been established there for about a year, has been so very successful that he has begun installing some new hearing rooms. His business has increased to such an extent that he found the necessity for these additional booths.

Returns From Business Trip

General Sales Manager George Boyd, who looks after the wholesale and retail business of the talking machine department of F. A. North & Co., has just returned from a business trip, during which he visited all of the firm's dealers in Pennsylvania and Virginia.

Hepe Enlarges Talking Machine Space

C. J. Hepe & Son have considerably added to the talking machine space in their recently enlarged branch store at Sixth and Thompson streets, which now takes in 1300, 1302, 1304 and 1306 North Sixth street. It is now the largest exclusively music store outside of Chestnut street that sells pianos and Victrolas. R. F. Lehman is the manager.

Again on Duty

George D. Ornstein, one of Philadelphia's talking machine jobbers, who has been absent from his place of business since last Spring, was again able to report for duty toward the end of October.

Steadily Adding to Emerson Dealers

The Philadelphia Emerson Co., Harry Fox, the head of the concern, reports that it is adding new dealers each week to the already considerable list of handlers of the Emerson phonographs. Its business in October was the best it has experienced in any month of the year. The Philadelphia Emerson advertising campaign is continuing to progress and it is bringing very good returns to the dealers.

Says Conditions Are Righting Themselves

A. J. Heath & Co. have no complaint of their October business and say that conditions are righting themselves rapidly. Last week they went about 80 per cent of the last week in September. Otto Heineman, the president of the

(Continued on page 96)



The **“NEW”**
MOTROLA

WITH UNIVERSAL MOTOR

Retail \$19.50

(former price \$30)

This marvelous little electric, self-winding mechanism attached to any type Victrola or any make Talking Machine will accomplish what the self-starter did for the automobile.

We, as exclusive wholesalers in Eastern Pennsylvania, New Jersey and Delaware, of the New Motrola with universal motor, are ready to fill your orders now.

Write for Trade Discounts

H. A. WEYMANN & SON, Inc.
1108 Chestnut Street
PHILADELPHIA



A New Fox-Trot - Melody
"ONE KISS"
 Will fill your heart with bliss

"You can't go wrong with any 'feist' song"

ASK TO HEAR IT.

THE TRADE IN PHILADELPHIA AND LOCALITY—(Continued from page 94)

General Phonograph Co., was a Philadelphia visitor. Charles Lamm, in charge of the Baltimore branch, spent several days in Philadelphia during the month, and he reports that business has been quite good in the Monumental City and that they are anticipating a good business, at least, up to the first of the year.

Buehn Reports Victrola Shortage

Business has been very good during the past week at the Louis Buehn Co. establishment. The company reports that there is a shortage of several styles of Victrolas, particularly No. 300. The belief was expressed here that most of the dealers have safeguarded their interests by laying in their stocks for the expected holiday rush at an early date. Among the recent visitors at the Buehn headquarters was W. E. Holland, of the Robelin Co., Wilmington, Del.

A model shop has just been completed on the first floor of the Buehn establishment, which contains miniature record racks, tables, cases for supplies, etc., as erected for them by the Unit Construction Co. It has great value as a stimulator of ideas.

Columbia Sales Meeting

Many outstanding features in successful advertising were brought up at the sales meeting held in the Philadelphia branch of the Columbia Graphophone Co.'s Model Shop on Saturday last. The "Advertising Contest for Columbia Dealers" was released at this meeting. The principal speaker was J. D. Westervelt.

Everybody's Designs Trade Chart

Everybody's Talking Machine Co., 38 North Eighth street, will soon present a new chart to the trade which is being designed to act as an aid to dealers in selecting the proper kind of mica for their particular use. An especially large supply of mica has been laid in. Special discs are being featured for sound boxes. The firm has been enjoying a very substantial business during the past month and Everybody's Uman-Tone

needles continue to enjoy a strong demand. There were many trade visitors during the week.

Weymann Featuring the Jones-Motrola

H. A. Weymann & Son, Inc., of this city, who are distributors of the Jones-Motrola, have featured this electric winding device in an energetic manner. Not only has the Jones-Motrola re-

ceived considerable window display space, but space in the local papers of this city has been devoted to it as well. This company have a standing order for a substantial number of Motrolas to be shipped each month, but have found it necessary to wire for more before the date of the next shipment.

THE SELECTION OF BUSINESS LOCATIONS IMPORTANT

Some Interesting Psychological Facts in Regard to the Habits of Purchasers in the Matter of Patronizing Stores—Hence the Value of Location Is an Important One to the Retailer

The selection of business locations is always a moot subject with men keen to every opportunity of developing business, and there are many of them in the talking machine trade. Hence the pertinence of an article in a recent issue of Forbes Magazine in which Charles C. Nichols, president of the Chain Stores Leasing Corp., points out that "it is an interesting psychological fact that women buyers will walk to a basement more readily than they will take an elevator, and that where you have a broad stairway with a wide opening near the front of the store, as in 5- and 10-cent stores, women will catch sight of the merchandise and walk down without question, either forgetting or ignoring the return trip. Second floor locations must also be carefully scrutinized, as men will walk up one flight to save money. However, from a standpoint of lowered expenses it is a question whether the merchant saves anything in the long run on a second-floor location, as he must spend much more, proportionately, in advertising.

"Another thing to which I pay the greatest attention is the traveling population. I watch to see where people get on and off the cars and analyze the general types. I study them to see whether they are the transient kind which only brings 'drop in' business for drug and cigar stores. These I classify differently from the

type which comes prepared to purchase. There is also what I call 'station traffic,' consisting largely of commuters; such persons are always in a hurry and usually add little to the coffers of the adjacent merchants.

"In visiting a city or town I study carefully the advertising of local merchants, watching to see what part of this is regular advertising and what part is that of the merchant who is not located desirably and who must spend money in advertising to coax the customers to his store. I also pay particular attention to the difference in the classes of people frequenting different blocks. One block may be popular with the customer buying the cheapest class of goods, the second with those interested in things of moderate price, while the third may draw the highest class of trade. I am also much impressed with the fact that the blocks given over to women's trade are usually shunned by men.

"There are two distinct types of location known to real estate men—men's and women's. As a rule the shady side of the street is the women's side, and rentals are about 25 per cent higher. Where one side of the street develops women's business, the other side stands fair to be good for men. It costs more in every way to do business in a woman's shop than in a man's, but women spend more money on clothes."



Size: 12½ x 11½ x 6
Weight 16 lbs.

DEALERS SAY—Their Success With Popular Priced

**"ALL—YEAR—ROUND"
CIROLA PHONOGRAPHS**

**IS
UNPRECEDENTED
IN THE HISTORY OF THE TRADE**

**CIROLA DISTRIBUTING CO., Inc.
204 Colonial Trust Bldg.
PHILADELPHIA, PA.
U. S. A.**

**SMALL INVESTMENT
FOR DEALERS**

**RETAIL PRICE \$35.00
LIBERAL DEALERS' DISCOUNT**

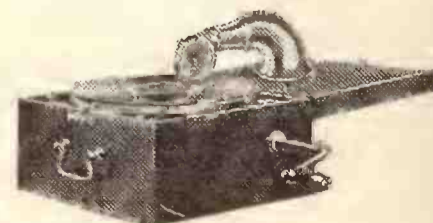

A Phonograph with three wonderful tones at a price which meets the demands of present-day business conditions

IMPROVEMENT IN KANSAS CITY TRADE IS MOST MARKED

Many Talking Machine Men Attend Convention of the American Legion—Edison Boosters' Club Organized—New Stores Opened—Financing of Dealers Meets With Favor—News of Month

KANSAS CITY, Mo., November 4.—The big news feature here, of course, has been the convention of the American Legion, which attracted close to 50,000 people to Kansas City. There was plenty of music throughout the period of the convention, which was opened by Mme. Schumann-Heink with the singing of the national anthem. There were bands without number to enthrall the visitors.

Among those who attended the Legion convention were a large number of talking machine dealers from all sections of the country, who were well entertained by local jobbers and dealers, many of whom took the opportunity of visiting the various Kansas City shops, studying the equipment and inspecting the machines on display.

Among the visitors to the convention was L. A. Murray, of Davenport, Ia. Mr. Murray is an exclusive Victor dealer and he is the president of the Iowa Victor Dealers' Association. There are, he said, only about a half a dozen States in the Union that can boast of a Victor Dealers' Association and he is rather proud of the fact that he is one of the few men in the world that has the distinction to preside over such an organization. He does not want to remain such, however, for he has an ambition to see the number of such associations greatly increase during the year. Mr. Murray is quite sure that not only the interests of the dealers will be promoted by the formation of such organizations, but that the general interests of all departments of the Victor industry will be benefited.

Business is better. Some are saying that the increase in the price of oil in Oklahoma and Kansas has helped some. Others are saying the raise in the price of cotton helped out. Others are saying that the low price of corn is holding business back. But for whatever causes it is better, the fact seems well established. One jobber reports that his October business is 50 per cent better than his September business. Another says that he is having some trouble in getting enough goods from the factory to meet his demands. Another says his increase in business is gradual and the prospects are good for a continued growth. Everybody seems to be expecting a good trade for the holidays.

One of the things that has helped the Brunswick and the Columbia people out is their systems of financing their dealers, so they can sell on the instalment plan and still not be embarrassed for funds to carry on their business. These companies have arranged to have the paper taken care of and thus have the dealers relieved.

Among the expansions in business in Kansas City is the opening of a new store by the Brunswick Shop. It will be just off of Petticoat lane and will be a model shop. It will be opened about the middle of November. There are twenty-five mechanics working on the decorations and fittings, in order to rush it along.

On the other side of the Kaw, in Kansas City, Kan., Butler & Son are also spreading out and are opening a new Brunswick shop at 1015 Central avenue.

Dealers and jobbers are reporting that the new models are appealing to the public and that there is an extra large demand for the better grades

of machines. One dealer stated that when he made a special term on the models that had been discontinued and referred in his advertising to the newer models that he wanted to make room for large numbers of persons came in to see the new models to which reference had been made in the advertising.

A. A. Trostler, secretary of the Schmelzer Co., Victor jobber, is quite optimistic about the outlook for a good holiday trade. Orders for both machines and records are coming in at an encouraging rate and everything points to a very satisfactory trade.

The "Edison Boosters' Club" is the name of the organization that is being worked up to continue the high mark of sales which was reached in Kansas City territory during the recent contests. Sales Manager Bailey, realizing that, in most cases, a slump follows a drive, determined that he would change the order and have things move right along at high tide. So he called a conference, at which he had a dealer to give the dealer's point of view and worked out a plan which has been enthusiastically received and which promises to be a winner. In the contest, which ended with the successful dealers going on the Eastern trip, one of the features of the work done by the successful men was to secure the co-operation of the Edison owners. The new sales plan is worked out around that idea. Instead of the dealer taking the trip this time the owner who helps the dealer secure customers is to be rewarded. The trip will be to Kansas City and the features of the trip will be: Rooms at the Muehlbach, luncheon at the Baltimore, auto trip over the boulevard system, chicken dinner at Field's Chicken Farm, theatre party, lunch at the Muehlbach Grill, with dancing for those who desire it, and next morning, breakfast at Fred Harvey's dining room at the depot—all expenses paid.

G. T. WILLIAMS OPTIMISTIC

That the year's total business will far exceed the expectations of earlier months is the opinion of G. T. Williams, head of the G. T. Williams Co., Inc., Victor distributor, Brooklyn. He says: "Retailers have stocked substantial quantities of goods for the holiday season and have arranged intensive sales drives to move stock. A normal holiday demand will reach the average dealer's quota of sales and the Victor retailer is imbued with the 'sales' spirit and the year, despite any earlier outlook, is concluding most favorably."

March & Leve, Victor dealers of Denver, Col., are the latest addition to the music stores of that city. Mr. March was formerly with the Sharp Music Co. and Mr. Leve was a member of the firm of Bechtold & Leve.



The Value of a Name



on a package of needles is a guarantee of needle profits for the dealer, as Sonora is firmly established in the mind of the public as being synonymous with "quality" both in phonographs and needles.

Sonora Semi-Permanent needles are desirable from the user's point of view, because they will play any make of steel needle records a great many times without injuring either the record or the quality of the tone.

Make it EASY for your customers to secure these needles by displaying them in a prominent place.

Order your stock now.

CAUTION! Beware of similarly constructed needles of inferior quality.

Sonora Phonograph Company, Inc.

GEORGE E. BRIGHTSON
President

279 Broadway New York

Canadian Distributors:
I. Montagnes & Co., Toronto

"BLACK DIAMOND" GRAPHITE Spring Lubricant The Lubricant Supreme



Guaranteed not to dry up or become sticky or rancid; retains its smooth, silky touch indefinitely. Prepared in just the right consistency in collapsible tubes; 1/2, 1, 5, 10, 25, 50 lb. cans.

Manufactured only by
HARTZELL CRUCIBLE CO.

North Side, Pittsburgh, Pa.
Manufacturers' Representatives

LOUIS A. SCHWARZ, INC.
1265 Broadway, New York City
21 East Van Buren St., Chicago, Ill.
525 Forsyth Bldg., Atlanta, Ga.

FOR SALE BY ALL LEADING JOBBERS

DECALCOMANIA

Name Plates for Talking
Machines, Pianos, etc.

High Class Workmanship

Write us for further information

National Decalcomania Co.

220-230 N. 60th St., Philadelphia, Pa.

USES ROOF TO ADVANTAGE

Sonora Dealer Erects Effective Electric Sign— Starts Sales and Publicity Campaign

MILWAUKEE, WIS., November 7.—The Wm. Kaun Music Co., of this city, which recently acquired



Great Sign of Wm. Kaun Music Co. the Sonora line, lost no time in making good use of the roof of its building for advertising purposes. Located but a few doors away from one

of the most prominent corners in Milwaukee, a Sonora sign was constructed facing the corner in plain view of the thousands who pass this corner daily.

This enterprising dealer is enthusiastic regarding the sales possibilities of the Sonora line in its territory, and it is planning an aggressive publicity and sales campaign for the holiday season. The Sonora is well known in Milwaukee, and the Wm. Kaun Music Co. is to be congratulated upon securing this agency.

MUCH MUSIC AT TEXAS STATE FAIR

Local Music Houses Have Elaborate Exhibits and Provide Interesting Concert Programs During Week—Dallas Music Industries Association Plans a Very Active Season

DALLAS, TEX., October 31.—The piano and talking machine dealers of Dallas were prominently represented with exhibits at the Texas State Fair, held here last week, and a number of them also had special displays and musical programs in their stores for the benefit of fair visitors.

Thos. Goggan & Bros., of which E. D. Browne is manager, had an interesting display of Steinway pianos and Duo-Art reproducing pianos at the fair and gave some interesting demonstrations. The Bush & Gerts Piano Co. also had an elaborate exhibit of Mason & Hamlin, Hardman, Bush & Gerts, Hazelton, Jesse French & Sons and other makes of pianos, together with Victor talking machines and records and musical merchandise. There was an exhibit of Sonora phonographs and Okeh records and other instruments of wide reputation.

The Will A. Watkin Co., during Fair Week, held concerts each day, both morning and evening, featuring the Ampico in the Chickering. The D. L. Whittle Music Co. featured the Ampico in the Knabe in a special program at the Thomas Theatre. Sanger Bros. kept open house in the company's music salon on the sixth floor, providing elaborate programs of piano and talking machine music. The Texas-Oklahoma Phonograph Co. featured the New Edison in a

ILSLEY'S GRAPHITE PHONO SPRING LUBRICANT

Ilsey's Lubricant makes the Motor make good
Is prepared in the proper consistency, will not run out, dry up, or become sticky or rancid. Remains in its original form indefinitely.
Put up in 1, 5, 10, 25 and 50-pound cans for dealers.

This lubricant is also put up in 4-ounce cans to retail at 25 cents each under the trade name of

EUREKA NOISELESS TALKING MACHINE LUBRICANT

Write for special proposition to jobbers.

ILSLEY-DOUBLEDAY & CO., 229-231 Front St., New York

big way, and the Brunswick Phonograph Shop, with its bungalow house, also attracted many visitors.

Building of a music temple in the State Fair Grounds may be completed for use at the fair in 1922.

F. H. PUTNAM'S FATHER-IN-LAW DIES

PEORIA, ILL., November 5.—Albert G. Emerson, who was considered the dean of Peoria traveling salesmen and for forty-eight years a resident of Peoria, died last week at the home of his daughter, Mrs. Fred H. Putnam, wife of the president of the Putnam-Page Co., Victor distributor. Mr. Emerson, who was seventy-nine years of age at the time of his death, had resided in Peoria for forty-eight years and had been a traveling salesman for forty-seven years. He was a veteran of the Civil War, and was active in many important civic and industrial affairs. He is survived by three daughters, including Mrs. Putnam, Mrs. Arthur F. Planck, of Chicago; Mrs. Ernest Quick, of Bonham, Texas. He is also survived by six grandchildren and four great-grandchildren.

LAWSON STOCK SOLD AT AUCTION

A bankruptcy auction sale of the stock and fixtures of the Lawson Piano & Phonograph Corp. was held at the factory, 2395 Park avenue, New York, on Wednesday, October 18. The highest bulk bid for the contents of the plant was \$1,700. The various parcels were auctioned off separately and brought approximately \$2,425.

A New Model in the Natural Voice Line

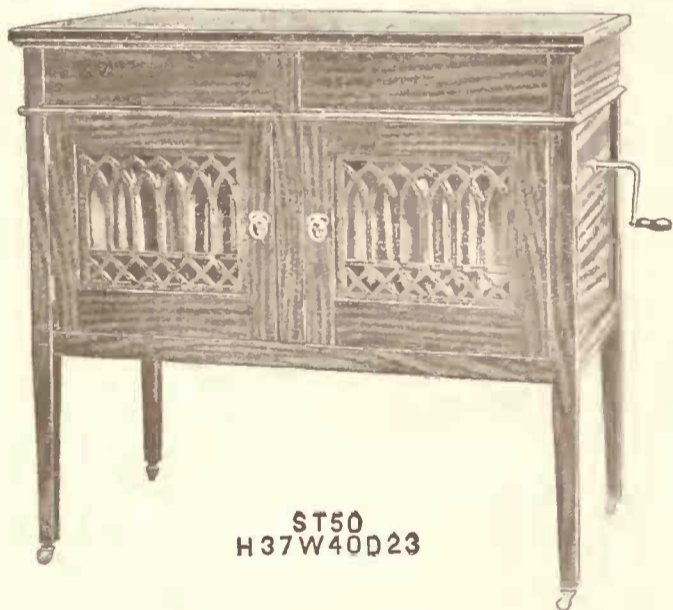

ST50
H37W40D23



ST53
H37W40D23

To the models already manufactured to meet the needs of the trade we have added this new style.

The NATURAL VOICE is a high-quality product selling at a popular price. It is a complete line including several period models.

Manufactured by expert cabinet makers it has achieved a position of prominence as a sales creator and profit maker.

Also a Full Line of Cabinets Without Equipment.

Write for Prices

It will pay you to investigate our proposition.



ST9
H50W23D24

The New Style No. 9 is a worthy addition to this complete line

Natural Voice Phonograph Co.
ONEIDA, NEW YORK



Okeh Records

LATEST DANCE

and

VOCAL HITS

- 4452 TUCK ME TO SLEEP IN MY OLD 'TUCKY HOME—Fox-trot Rega Dance Orchestra
- 10 in. { EVERYBODY STEP (From "The Music Box Revue")—Fox-trot,
85c { Banjo by Harry Reiser (Accomp. by Rega Dance Orchestra)
- 4453 THE MISSING LINK—A Blues Fox-trot The Tampa Blue Jazz Band
- 10 in. { MYSTERIOUS BLUES—Fox-trot Joe Samuels' Jazz Band
85c {
- 4454 SWEET LADY (From the Musical Comedy, "Tangerine")—Tenor-Contralto Duet with Orchestra,
10 in. { Billy Jones and Vaughn De Leath
85c { JUST SUPPOSE—Contralto-Baritone Duet with Orchestra Helen Clark and Joseph Phillips
- 4455 JEALOUS OF YOU—Tenor with Orchestra Billy Jones
- 10 in. { I WONDER WHO (You're Calling Sweetheart)—Contralto with Orchestra . . . Vaughn De Leath
85c {
- 4456 TEN LITTLE FINGERS AND TEN LITTLE TOES (Down in Tennessee)—Tenor-Baritone Duet
10 in. { with Orchestra Billy Jones and Ernest Hare
85c { PLANTATION LULLABY—Male Quartette with Orchestra Shannon Four

General Phonograph Corporation

OTTO HEINEMAN, President

25 West 45th Street, New York City



ORMES, INC., OCCUPIES HANDSOME NEW HEADQUARTERS

New Home of Victor Wholesaler, 15 West Thirty-seventh Street, New York, Arranged on Elaborate Scale and Is Most Attractive in Every Particular—Facilities Provided for First-class Service

Ormes, Inc., Victor wholesaler, is now located in its new home on the fifth floor of the recently completed building at 15 West Thirty-seventh street, New York. The removal from this company's former quarters on 125th street was made in exceptionally fast time and the Ormes clientele is now receiving service from the new home.

Clarence L. Price, vice-president and general manager of the company, who personally supervised every detail incidental to the moving, deserves unlimited praise for the care and consid-

maximum service and co-operation to the company's clientele. He accomplished this purpose admirably and every detail of the Ormes floor is adaptable to a most perfect system of dealer co-operation.

Immediately upon stepping from the elevator the visitor enters a reception foyer that is without doubt one of the most artistic and attractive rooms of its kind in the talking machine industry. The furnishings are noteworthy for their dignity and refinement and the visitor is immediately given an impression of comfort and

model Victrolas, with attractive furnishings in keeping with the prestige of the instruments displayed.

The Dealer Service room is noteworthy for its practical value to the Victor dealer, as there is presented in this room every possible form of advertising and sales help that has been endorsed by the Victor Talking Machine Co. as helpful to the Victor retailer. This display will be kept up to the minute in every particular and can be used to splendid advantage by the Victor dealer.

The growth of the Ormes business during the past few years has been phenomenal, with Mr. Price devoting all of his time to the executive and sales divisions of the business. Through his many years' experience in the Victor industry



Views of New Home of Ormes, Inc. 1—Reception Foyer. 2—General Offices. 3—C. L. Price's Private Office. 4—View of Record Vaults

eration that he bestowed on every phase of this important move. In its present quarters Ormes, Inc. has one of the most attractive and up-to-date wholesale establishments in the country and Mr. Price is receiving congratulations from all Victor dealers and jobbers who visit the new Ormes headquarters.

The building at 15 West Thirty-seventh street is ideally located, as it is only a few doors from Fifth avenue and the Sixth avenue elevated line, with the Broadway and Sixth avenue surface cars only a half-block away. The Seventh avenue subway is also nearby and the Fifth avenue shopping district, with its thousands of out-of-town visitors, is adjacent.

In laying out his new quarters Mr. Price's first consideration was the equipment of a wholesale establishment that would be able to render

warmth that is emphasized in every detail of the floor's furnishings.

To the left of the general offices is situated Mr. Price's private office, and this office was also furnished with the one thought in mind of making the visitor feel perfectly at home. Leading from the general offices are the record vaults, stock room and general shipping department. The record vaults are metal throughout and thoroughly up to date in every detail. Ample facilities are afforded for the shipping department and stock room and Mr. Price has already made arrangements for the installation of a thoroughly equipped repair department.

To the right of the reception room are two handsomely decorated rooms, which will be known as demonstration and Dealer Service rooms. The former contains several period

he has acquired an intimate knowledge of every phase of the merchandising of Victor products and has co-operated with the Ormes clientele along practical lines that have contributed materially to the success of the institution and the value of its service.

THE BRUNSWICK IN STROUDSBURG

STROUDSBURG, PA., November 3.—Lanterman's Music Shop, of this city, recently secured the agency for Brunswick phonographs and records. The proprietor, Mrs. J. H. Lanterman, has started an extensive advertising and sales campaign to push these machines and records in this vicinity. The Lanterman establishment is the only local music shop which handles the Brunswick line.

TRIPLE PHONO PARTS CO.

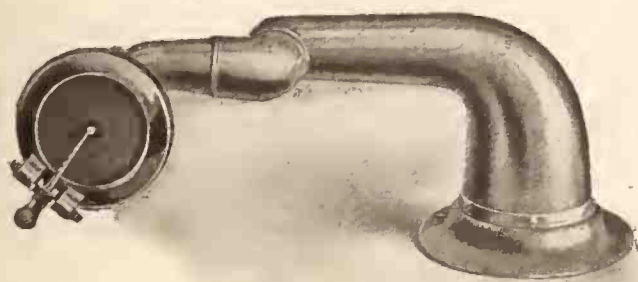

Various Styles and Designs to Meet Every Requirement

Prices \$2.50 to \$6.00

Samples on Request

Triangle Phono Parts Co.

722 Atlantic Ave. Brooklyn, N. Y.
Telephone Sterling 1120

VELVET AND FELT TURN-TABLE DISCS

by the dozen or in thousand lots, with or without cardboard disc.

We supply the jobbers and manufacturers of all the high-grade machines and have the best equipped cutting plant of the kind in the world. Table, desk and cabinet Felt, any color, cut to size.

If you require anything in FELT, or made of FELT, we can serve you.

MONARCH FELT WORKS, Inc.
39-45 York Street Brooklyn, N. Y.

**THE MOST SENSATIONAL DANCE
HIT WE EVER PUBLISHED**

WABASH BLUES

**ASK ANYBODY IN CHICAGO
TRAVELING EAST-FAST**

*"You can't go wrong
with any 'Feist' song"*

INDIANAPOLIS DEALERS LOOK FOR GOOD HOLIDAY TRADE

Talking Machines and Records Moving More Quickly and on a Better Merchandising Basis Than for Some Time—Establishments and Sales Forces Expanded—Monthly Letter Tells the Story

INDIANAPOLIS, IND., November 8.—Contrary to business conditions among the piano dealers of Indianapolis, which are not satisfactory, the talking machine dealers report increasingly better business with everything pointing to a lively holiday trade. Practically without exception the leading dealers say that both machines and records are moving better than they have any time this year.

Sonora Business Improving

Business is better among the Sonora dealers of the State, according to O. C. Maurer, manager of the Sonora department of the Kiefer-Stewart Drug Co., State distributor. He says the recent reduction in Sonora prices has encouraged the dealers to renewed efforts with the result that prospects are for a nice steady business through the remainder of the year. Sales, he says, are as frequent in the \$200 and \$300 as in the lower-priced machines.

Concerts Help Taylor Business

Miss Minnie Springer, of the Taylor Carpet Co., reports business in Victrolas picking up. She says the number of sales in the last three or four weeks has been very encouraging. She reports good returns from the recent concert of the Eight Famous Victor Artists.

Two Join Widener's Staff

T. E. Gardner, as an outside salesman, and Miss Helen Ike, as a record saleswoman, have been added to the sales force of Widener's Grafonola Shop. W. G. Wilson, manager, reports better business in both the Granby and the Columbia machines and also increased sales in Columbia records. He says the adding of the Granby machines to the line carried by the store has done much toward bringing increased business. The new \$175 period model of the Granby is in particular favor, according to Mr. Wilson. Reports received from the territory in southern Indiana and Kentucky being covered for the Granby are that the machine is meeting with exceptional favor.

Victor Dealers Charge Interest

Victor dealers in this city now are charging 5 per cent extra on all Victrolas sold on the installment plan. The charging of interest has been in effect nearly a month and, according to reports, there has been no change in the machine business. One reason given by some of the dealers for making the change from the old plan of accepting deferred payments without interest is that instances have been known in which customers able to pay cash have bought on deferred payments simply because no extra charge was made by the dealer.

Victrolas Lead in Sales Contest

In a contest among the various departments of the store of the Pettis Dry Goods Co., of this city, the Victrola department won first honors by showing an increase of 140 per cent over last year, when a similar contest covering a period

of ten days was held. The prize for winning the contest was \$10 given to each clerk in the department. Speaking of the contest, Ira Williams, head of the department, said: "It required hard work for us to come out first this year and the final results were very much in doubt until the last minute. The terms which we were able to secure were unusually good, and, considering everything, I am very well pleased with the showing we made."

Music Course Attracts Patrons

L. S. Ayres & Co., owning one of the leading department stores in the city, have established as an added service to the customers of their Victrola department a free course in music history and appreciation. Miss Caroline Hobson, of the Stewart Talking Machine Co., is acting as lecturer during the course. The course embodies and deals with interesting facts and stories of the world's best music. The beautiful tea room of the store is turned over entirely to the classes between 9.30 and 10 every Tuesday morning. Such subjects as "Principles of Music," "History of Music," "The Orchestra," "The Opera" and "The Oratorio" are discussed as a part of the course.

Mr. Follis, manager of the department, says the service, which is offered gratis by the department, is doing much to stimulate the sale of Red Seal records among his customers. Several dealers outside the city are planning to carry out the same idea, using local music teachers to aid them.

Victor Artists Hold Concerts

The Eight Victor Artists, appearing in the largest theatre of the city, packed the house on a recent Sunday night. Glowing accounts of the entertainment appeared in the newspapers and the whole effect of the concert was a noticeably increased demand for records made by members of the group of artists.

Adds Five to Sales Staff

Five men have been added to the outside sales force of the Indianapolis Talking Machine Co., and a house-to-house canvass is being made in the city. As part of the plan for thus covering the city weekly meetings are held between the outside salesmen and J. R. Jones, a member of the sales force of the Stewart Talking Machine Co.

A. C. Hawkins, manager of the Indianapolis Talking Machine Co., reports that the business of the first three weeks of October showed that the month would be ahead of the corresponding month last year. Sixty per cent of the sales during the month, he says, were made outside the store, whereas previously most of the company's sales were made in the store. As an indication of the business available for men who hustle, Mr. Hawkins reports that one of his outside salesmen, C. W. Larsh, put out five machines on approval and out of the five closed four sales in

Equip Your Booths with Stewart Record Stands



No. 5A 010

\$8.70

f. o. b.
Indianapolis

COMPACTLY built and designed especially for handling records conveniently in the demonstration rooms, this stand brings efficiency to your record selling.

The customer places on the top shelf the records he wishes to hear; on the bottom shelf those he does not want, and on the middle shelf those he wants to buy. Result—no mix-ups and much time saved. A powerful aid to the busy dealer.

In Mahogany, Golden Oak and Birch finish. Height, 43¼ inches. Top, 16½ x 16½ inches. If you have no account with us please send check with order.

STEWART
TALKING MACHINE CO.
Victor Jobbers
INDIANAPOLIS



one week. Mr. Hawkins says the most serious problem he faces is the one of getting deliveries from the factory. He is substituting models now awaiting delivery of factory orders.

H. A. Brown Is Promoted

H. A. Brown, for the last nine months an Edison salesman for the Kipp Phonograph Co., has been placed in charge of the talking machine department of the Pearson Music Co. to succeed Thomas W. Hendricks, who resigned to take up work in a very different line. Mr. Brown heretofore has always been an exclusive Edison salesman, having been, prior to employment with the Kipp Co., one year with the Baldwin Piano Co. at Louisville, and nearly ten years with the J. M. Fisher Music Store at Anderson, Ind.

Does Record Business

During the third Saturday in October the record business at the Brunswick Shop was the largest of any day during the year, according to C. A. Grossart, manager. Mr. Grossart says the month brought better business in both machines and records with a large demand for the new models.

Sales Campaign for Amberolas

A selling campaign for Edison Amberolas to continue from October 15 to December 15 for a purse of \$500, to be divided into five prizes, has

A Message To Victor Dealers in Ohio, Michigan and Indiana

We now have the stock you will want a little later. Why hesitate?

THE TOLEDO TALKING MACHINE CO.
TOLEDO, OHIO

WHOLESALE



EXCLUSIVELY

been started by the Kipp Phonograph Co. The contest will be based on points made by the sale of the three types of Amberolas and will be conducted in the same manner as was the contest among the Edison Re-creation dealers that closed October 31. The first contest, according to H. G. Anderson, general sales manager of the Kipp Co., increased sales to a large extent in both machines and records.

Lectures Boost Business

The Victor Co. recently took advantage of the annual convention of the Indiana State Teachers' Association, held here, to press the claims for their school instruments through lectures given by Miss Margaret Streeter, of the educational department of the company, and Miss Caroline Hobson, head of the educational department of the Stewart Talking Machine Co.

Emerson Trade Booming

During October the Emerson dealers of the State ordered from eight to ten times as many records as they did during the previous month, says C. E. Collins, of the Collins Phonograph Co., Emerson distributor. He says the demand for Emerson records has been steadily increasing for several weeks past, while at the same time dealers have ordered more heavily in machines. The city retail business, he says, is improving slowly.

Pathé Orders Increasing

Reports and orders sent to the Mooney-Mueller-Ward Co., Pathé distributor, by E. J. Groenwoldt, salesman for Indiana and part of Kentucky, give evidence of much better business for the Fall and Winter. O. M. Kiess, manager of the Pathé Shop, reports that business in Indianapolis has improved, particularly among the middle-class buyers.

Mr. Kiess made a visit during the month to the home office of the Pathé Frères Phonograph Co. He says he found evidence there which indicates that business throughout the country is slowly but surely improving. En route to New York he stopped at Chicago, where he visited with W. W. Chase, president of the company. He says Mr. Chase is making an inspection trip to the Coast, and that as a result of his observations since starting on the trip he had become very optimistic as to the future.

E. R. Eskew, former manager of the Pathé Shop, is now on the road for the Interstate Phonograph Co., of Chicago, Pathé distributor in Illinois and northern Indiana. Mr. Eskew's territory is northern Indiana.

Kimball Sales on the Rise

Kimball talking machines are selling better than for several months and business in Kimball records is the best since last Fall, according to C. F. Kahn, of the Capital Paper Co. He says that E. H. Jarrard, manager of the talking machine department, who has been traveling the

past several weeks over the district covered by the company, reports conditions in Michigan to be better than in Indiana or Illinois. Mr. Jarrard has obtained about twenty new accounts. He reports that farmers are buying more freely and that the plan adopted by Kimball dealers to sell from trucks has proved successful. Mr. Kahn says the best trade in Indianapolis at the present time is found among the poorer class of buyers.

W. H. Cotter, manager of the Kimball Co., Chicago, was in Indianapolis the latter part of the month suggesting selling plans to the Kimball salesmen.

CONTRACT WITH MAY PETERSON

Metropolitan Opera Soprano Renews Arrangement to Record Exclusively for the Aeolian Co.—Great Popularity of Her Numbers

It was announced recently that May Peterson, the popular soprano of the Metropolitan Opera Co., whose exclusive Vocalion records have proven so popular, has renewed her con-



May Peterson

tract to sing exclusively for the Vocalion for a lengthy period. This is Miss Peterson's fifth season with the Metropolitan Opera Co. and she has won great success in the various rôles in which she has appeared with that organization.

Miss Peterson has done some excellent work personally to popularize her records, for, while on tour, she never fails to visit Vocalion dealers in the various cities of the country and help them so far as possible in their exploitation work. She has a generous number of records in the Vocalion catalog, the latest being "Se Saran Rose" (Love in Springtime), which represents an excellent piece of recording. In the December Vocalion list will appear Miss Peterson's interpretation of the old favorite, "Last Rose of Summer."

NEW PERIOD MODEL PRICE LIST

New Price List for Columbia Period Models—Dealers Featuring Line Extensively

The general sales department of the Columbia Graphophone Co. announced on October 15 a reduction in price of period Grafonolas. These reductions are substantial, and Columbia dealers throughout the country are now planning an aggressive sales drive featuring period models.

The new price list of these period models is as follows: P-1 Electric, \$500; P-1 Spring, \$475; P-2, \$550; P-3, \$600; P-4, \$700; P-6, \$550; P-7 Electric, \$525; P-7 Spring, \$500; P-8 Electric, \$450; P-8 Spring, \$425; P-9 Electric, \$600; P-9 Spring, \$575; P-20 Electric, \$275; P-20 Spring, \$260; P-21, \$600; P-26 Electric, \$450; P-27 Electric, \$350; P-27 Spring, \$325; P-28 Electric, \$325; P-28 Spring, \$300; P-29, \$325; P-30, \$350; P-31, \$325; P-32, \$375; P-33, \$375; P-34, \$300; P-35 Electric, \$300; P-35 Spring, \$275; P-36, \$475; P-37, \$800.



BLANDIN

THE Blandin can be unpacked and placed on your floor ready for customer's inspection in a few minutes, due to the ingenious way in which the shipping box is constructed. This box is also a sure protection against damaging the finish in any way. Our dealers are enthusiastic in their praise of Blandin service as well as the distinctive and superlative quality of Blandin phonographs. We want more dealers. Write for full particulars.

Racine Phonograph Co., Inc.

RACINE, WISCONSIN.



MULTUM IN PARVO

Retail merchants of the talking machine industry who are exerting a direct mail effort to sell records and instruments will be interested in knowing the experience of one user of the mail route as regards clips. This merchant sent out 5,000 test letters. In the first batch the enclosures were clipped to the letter itself. In the second batch the enclosures were sent out loose. Tabulation of the returns received showed that in the case where the enclosure was clipped to the letter the pulling power was 20 per cent greater.

The Farrar Furniture Co., of Bangor, Me., has added a Grafonola department to its store. Columbia machines will be handled exclusively by this company.

PERRY B. WHITSIT Co.

WHITSIT co-operation and service to the Victor dealer has been enhanced by the exceptional facilities afforded us in our new home. Visit us on your next trip to Columbus.

COLUMBUS OHIO

VICTOR DISTRIBUTORS



Model No. 40
 Mahogany — Walnut
 Height 49 inches Width 21¾ inches
 Depth 23¾ inches
 Cardinal Tone Chamber
 Tone Modifier Automatic Stop
 Cardinal Filing System
 Automatic Top Support Price \$175.00

TIFFANY PHONO. SALES CO.

1404 East 9th Street

CLEVELAND, OHIO

Distributors of

CARDINAL RECORDS

For Northern Ohio



OPEN VIEW OF MODEL NO. 40
 Showing Filing System
 and Cardinal Tone Chamber
 Filing System in Models Nos. 35, 40, 50, "B."
 Models No. 20 and No. 30 Fitted With Album
 Shelves
 Cardinal Phonographs Play All Records

New Models

CARDINAL PHONOGRAPHS

5

CABINET MODELS

2

CONSOLE MODELS



Model No. 30
 Mahogany — Walnut
 Height 44¾ inches Width 19½ inches
 Depth 21½ inches
 Cardinal Tone Chamber
 Tone Modifier Automatic Stop
 Automatic Top Support
 Price \$125.00

CARDINAL PHONOGRAPH CO.

137 West 4th Street

CINCINNATI, OHIO

Distributors of

CARDINAL PHONOGRAPHS

Dealers and Jobbers—

Write for Liberal Proposition on Cardinal Phonographs
and Records

Address

CARDINAL PHONOGRAPH CO.

106 EAST 19th STREET, NEW YORK CITY

FACTORIES — NEWARK, OHIO — ZANESVILLE, OHIO — BRIDGEPORT, CONN.

TRADE NOW NEARLY NORMAL IN BALTIMORE TERRITORY

Business Continues to Show Steady Improvement, According to Jobbers and Dealers—Victor Dealers' Association Activities—Noon and West to Open Store—News of Month

BALTIMORE, Md., November 7.—The talking machine business here is improving right along and each week shows an improvement over the corresponding week of last year, and this report is general from both the wholesale and retail trade. Dealers generally have started to advertise liberally in the daily papers and confidently look forward to a good business from now on until the end of the Christmas buying. Quite a number of new places are either opening up or preparing to open; in fact, as Manager Parks, of the Columbia Co., said, "We are receiving more applications for agencies than we can take care of."

The trade generally is now back to normal, or as near normal as is possible under existing conditions, and dealers are again buying in quantities so they will be able to show a complete line. "The retail trade is in a very healthy and flourishing condition right now," said H. T. Boses, manager of sales for Cohen & Hughes, Victor wholesalers for this section, "judging from the number of orders that we are receiving for machines and records. Every man in the business either now has a complete line in stock or has ordered what is lacking. Collections are better and every dealer that I have talked with is enthusiastic over the outlook for business this Winter."

The Victor Dealers' Association resumed its monthly meetings on the 26th of last month with a dinner at the Southern Hotel. F. A. Delano, of the Victor Co., was present and gave the dealers a very instructive talk on new selling methods, giving many valuable points on how to attract new business and the best methods of following up prospective customers. Mr. Delano's talk was followed very closely by those present and every dealer left feeling very enthusiastic over putting into effect some of the plans which he outlined. In this connection Cohen & Hughes have sent L. A. Randall, of their staff, to the factory for a course of instruction and when he returns he will devote his entire time with the retail dealers, spending a certain number of days in each store explaining and giving demonstrations of sales promotion schemes.

General Sales Manager Hopkins, of the Columbia Co., visited the local branch last week and attended the meeting of the salesmen of this territory. All the men made very encouraging reports of the business outlook in their respective sections and Mr. Hopkins announced that the company was going to inaugurate a national campaign of advertising that would be of great benefit to every Columbia dealer.

H. L. Tuers, manager of the dealers' service bureau of the Columbia, was also a visitor to the local branch for a few days last week for the purpose of getting in direct touch with the local trade in order to give the dealers full benefit of the service plans which are shortly to be put into operation throughout the country.

W. K. Stalling, formerly manager of the Graphophone department of the Graphophone Co., of Richmond, is now with the Graphophone Shop, of Norfolk, Va.

Walter B. R. Wright, managing director of the vigilance committee of the Advertising Club of Baltimore, Inc., who has been making a campaign against false and misleading advertising in the daily papers, has been invited and will make

an address before the next meeting of the Victor Dealers' Association, in which he will tell what has been done toward making "the truth in advertising" a success and what plans he has for the future.

Lester B. Harvey, of Oakville, Va., recently exhibited a Magnavox machine at the Appomattox Fair and made a big hit with it, as it was the first time the people of that section had ever seen anything like it. The managers of the fair were so pleased with it that they asked to announce the results of the races on it. Mr. Harvey, who, although a cripple and compelled to have an attendant with him at all times, is doing an excellent business, according to the local Columbia branch, his business so far this year being considerably ahead of the same period for 1920.

Visitors the past week included L. M. Howell,

of Portsmouth, Va.; Dr. Daniels, of Zebulon, N. C.; William Anderson, of Wilson Co., Wilson, N. C., and Turner & Bishop, Lewis & Co., William McFarquer and J. Davis, of Washington.

John Steele, one of the Victor artists, appeared here at one of the vaudeville houses a couple of weeks ago, and while here visited a number of the stores and sang selections of his records that the dealers had in stock. This made quite a hit with the dealers and resulted in a large increase in sales.

C. B. Noon, formerly with the Smith-Kranz Piano Co., and George P. West, former manager of the music department of Hecht & Bros., have formed a partnership and will shortly open a store here, carrying a line of both pianos and talking machines.

Meyer Goldman, well known to the trade of this section, has just been appointed supervisor of the United Graphophone Stores, Inc., of Washington.

Thomas A. Caulfield, of Owingo, Md., has just been appointed a Victor dealer for that territory.

New Prices for LONG Record and Roll Cabinets

Effective Nov. 1st, 1921, a new price list for LONG Disc Record and Music Roll Cabinets was announced to the trade.

This new price list represents a 15% reduction from our price list of April 1st, 1921, and is offered to the trade with the assurance that we are giving it full advantage of every possible form of reduction.

For November only we offer the LONG Cabinet No. 87 (illustrated) at the special prices listed below. This cabinet is ideally adapted for holiday trade, and is one of the most attractive models in our line. In order to cooperate with our trade and stimulate holiday business, we offer this cabinet at special prices for November only. Our stock of the No. 87 model is limited, and when it is exhausted the special prices will be withdrawn. We, therefore, suggest that you place your order now.

For
November Only
\$10.50

With Flat Top Shelves (for Columbia D-2 and other flat base models).

After Nov. 30, 1921, the price of this cabinet will be

\$14



Style 87

For
November Only
\$11.50

With Top Moulding Shelves (for Victrola IX only as shown).

After Nov. 30, 1921, the price of this cabinet will be

\$15

Geo. A. Long Cabinet Co., Hanover, Pa.

ACME-DIE

CASTINGS

ALUMINUM-ZINC-TIN & LEAD ALLOYS
Acme Die-Casting Corp.
Boston Rochester Brooklyn N.Y. Detroit Chicago

PITTSBURGH IS IN BUOYANT MOOD OVER TRADE OUTLOOK

Business Decidedly Better, Thanks to Improved General Conditions—Leading Jobbers Discuss Situation—Talking Machine Men Meet—Brunswick and Vocalion Increase Representation

PITTSBURGH, PA., November 7.—The past month proved a pleasant surprise in certain sections of the Steel City, as far as business conditions were concerned, a number of the dealers reporting that the volume of business handled for October in talking machines and records proved decidedly larger than that disposed of the month before. The open weather of the past six weeks has not been a factor to encourage sales of talking machines and records, but with the advent of rainy and chilly weather the past week the "folks at home" were inclined to remain at their firesides, and this, in turn, proved a circumstance which brings to remembrance in a forceful manner the talking machine and the pleasure that is derived therefrom.

General Tone of Business Is Much Better

The general tone of business in all lines and sales of talking machines in this city is much better than two weeks ago and the outlook for a good holiday season is bright. It is admitted on all sides that the industrial situation in the Pittsburgh district has improved most materially and mills that were operating at 40 per cent and even less a month ago are now producing at 65 to 75 per cent of capacity. This is also true of the coal and coke operations and, as a result, hundreds of men have gone to work the past ten days. While it is true that the wage scale will not be as high as the wages that prevailed two and three years ago, it is a great relief to the workers as a whole to know that they are sure of steady work for the next fifteen to eighteen months. Orders for iron and steel products have been coming in rather heavily the past three weeks and this all goes to enhance the prosperity of the district.

In turn, the wages that will be disbursed every two weeks from now on will be good sized and the circulation of the millions of dollars in this city and vicinity augurs well for all kinds of

business, the talking machine trade especially. It is a well-known fact that in the industrial and mill towns of the Pittsburgh district the demand for talking machines and records, when the mills are running full, is very heavy. This is true in a marked degree of the foreign-speaking workers, who are intensely fond of music in all forms. Poles, Russians, Hungarians, Italians, Slavs, Ruthenians, Czechs and other nationalities are keenly interested in songs in their native tongue, as well as in selections by their national artists. When the slump came in the industrial life of the Pittsburgh district, the talking machine dealers who specialized in foreign records, etc., were the first to feel the effect, and now as the upward trend in operations comes they are the first to feel the stimulating current of brisk business.

Reasons for Optimism

On the whole there is an optimistic tone in the talking machine trade here and dealers are preparing for a brisk holiday trade. S. H. Nichols, manager of the Pittsburgh offices of the Columbia Graphophone Co., said to the Talking Machine World representative:

"We are prepared to handle what we expect will be a very excellent holiday trade in the Columbia Grafonolas and records. The turn in trade has come from the industrial marts of the Pittsburgh district and adjacent sections and I feel that it will have a good effect on all other lines of trade. We feel that with the aid of our service department we will be able to give splendid co-operation to all Columbia dealers and aid them in taking care of the business that undoubtedly must come to them. We feel very hopeful as to the immediate future and are convinced that the business is there to be secured by the dealers who go after it in a systematic and persistent manner. The general outlook is good and I see no reason why every Columbia dealer should not be able to do a very nice busi-

ness from now on until the Christmas holiday trade is over."

Thomas T. Evans Reviews Situation

Thomas T. Evans, manager of the wholesale Victrola department of the C. C. Mellor Co., said: "We look forward to doing the usual good business that this firm has always handled in the months of November and December. We have service to offer to Victor dealers second to none in the country and in many points superior to many offered. The outlook is good as far as I can see and it is my candid opinion that it will be a larger and better Victor season for our department than we experienced a year ago. The mills and mines are gradually getting back to normal operations and this is bound to have a beneficial effect on the Victor trade all over the Pittsburgh territory."

W. C. Hamilton Back at His Desk

Wm. C. Hamilton, president of the S. Hamilton Co., Victor dealer, and president of the Piano Merchants' Association of Pittsburgh, is back at his desk again after a stay in a New York hospital following an operation for appendicitis. Mr. Hamilton's many friends in the trade were glad to see him restored to his field of useful endeavor in the talking machine and music circles of the Steel City.

Many New Brunswick Dealers

J. A. Scanlan, Jr., sales manager of the Brunswick phonograph division of the Brunswick-Balke-Collender Co. in the Pittsburgh district, is lined up securely with the optimists in the talking machine trade who are convinced that business is reviving and that the outlook is brighter today than it was six weeks ago. Mr. Scanlan said in referring to business conditions: "We feel that our efforts this Fall and Winter for new business will be rewarded in a very handsome manner. There is no doubt but that the earnest and conscientious retail Brunswick dealer will be able to do better and larger business through the co-operation that our company extends to him." Mr. Scanlan stated that the following new Brunswick dealers will, in the future, be served by the Pittsburgh offices: A. M. Armstrong,

Individuality in Your Product Will Mean More Sales for You!

The New Empire Universal Ball Bearing Tone Arm and Reproducer

Made in Two Lengths:
8" and 9"

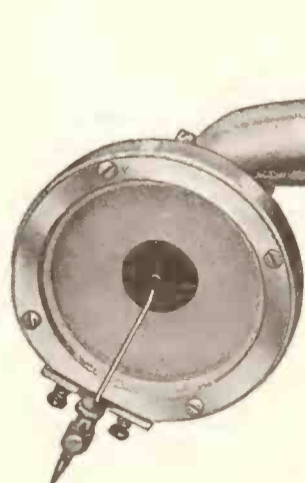

WE are prepared to submit to reliable manufacturers samples of our tone arms and reproducers in order to enable them to determine the merit of our product. Our prices are low and the quality of our product is second to none.

Write or wire us for samples and quotations and give us an outline of your requirements.

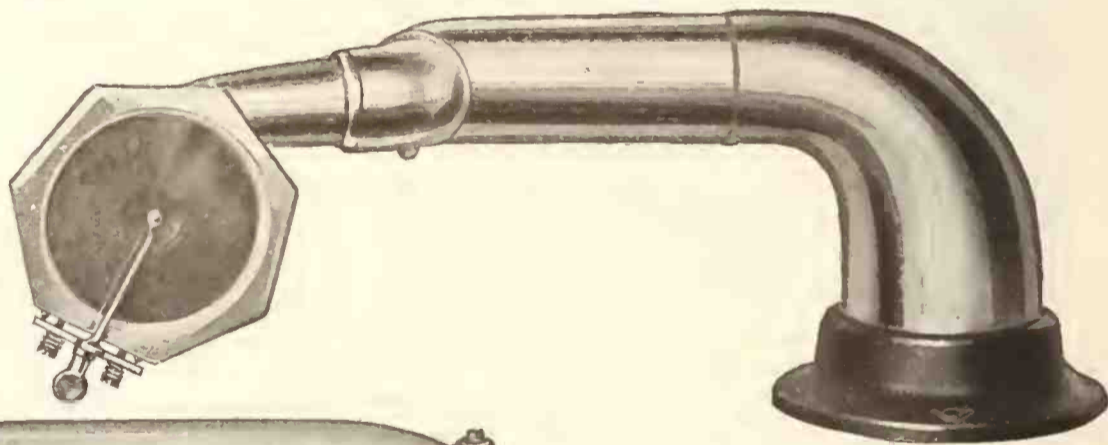

The Empire Universal Pivot Base Tone Arm and Reproducer

Made in Several Lengths.



THE EMPIRE PHONO PARTS COMPANY, 1362 East Third Street, Cleveland, O.

Established in 1914

Manufacturers of High Grade Tone Arms and Reproducers

W. J. McNAMARA, President

Now **98 c.**

RETAIL

The "PHONO-MOVIES"

The High-class Phonograph Entertainer

Always a diversified performance

A highly perfected amusement feature. The animated antics of the "Phono-Movies" will produce the laughter and merriment you seek at a three-ring circus.

Now is the time to stock the "Phono-Movies" for the holiday trade and enable customers to enjoy this happiest of fun-making, mirth-producing novelties.

The "Phono-Movies" are irresistible in their appeal to the phonograph owner, and as the cost does not exceed the price of some records the outfit is within the reach of all.



PHONO-MOVIES

Patented Feb. 11, 1919, and other patents pending



Dancing Dorky



Ballet Dancer

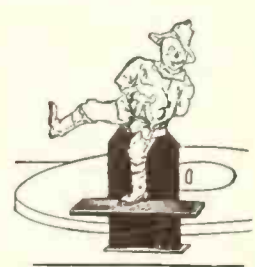

Scare Crow

COMMERCIAL ART SHOP, Covington, Ky.
Find enclosed 98c for complete "Phono-Movie" sample outfit and money-making particulars.

Name

Address

In addition to the three parts that comprise the working device, three "Phono-Movie" subjects are included with each set. Operated by disc phonograph without attachments of any kind.

This "made in the U. S. A." novelty of merit, well boxed, all complete with directions.

Use the coupon for sample and money-making particulars.

Commercial Art Shop
Covington, Ky.

Apollo, Pa.; T. Reed Ashbaugh, East Liverpool, O.; Brown's Music Shop, Kittanning, Pa.; De Foreest & Son, Sharon, Pa.; East Hill Brunswick Shop, Sharon, Pa.; A. G. Ditmer, Butler, Pa.; E. H. Hutson, New Bethlehem, Pa.; S. J. Lowry, New Kensington, Pa.; Ullom & Bailey, Waynesburg, Pa.; David Hirshberg, Vandergrift, Pa.; Melody Shop, Bellaire, O., and the East Liverpool, Toronto and Selineville, O., stores of the Smith-Phillips Music Co.

Miss Lillian A. Wood Resigns

Miss Lillian A. Wood, who for several years was in charge of the educational department of the C. C. Mellor Co. Victor branch, has resigned. Rumor has it that "wedding bells" will ring soon. Miss Wood wears a handsome solitaire and declines to be quoted.

Discuss Formation of "Record Exchange"

At the October meeting of the Talking Machine Dealers' Association of Pittsburgh steps were taken looking to the formation of a "Record Exchange" for the exclusive use of the membership. The plan is to have the members exchange through this central agency such records as they wish to pass on to other localities where the sales possibilities are greater. The matter was thoroughly discussed and it was decided to let the executive committee and officers work out a plan of operation which will be presented at the regular meeting of the association in November. The October meeting was the first officially presided over by Herman Lechner, the new president. Jobbers who attended the meeting were J. C. Roush, Wallace Russell and French Nestor, of the Standard Talking Machine Co., Victor distributor; George H. Rewbridge, of the W. F. Frederick Piano Co., Victor distributor, and A. A. Buehn, of the Buehn Phonograph Co., Edison distributor.

The Sonora Headquarters in Pittsburgh

The Sonora Distributing Co., of Pittsburgh, the new wholesale Sonora agency in this city, is now located in the Jenkins Arcade, with H. Milton Miller as sales manager. Frank J. Coupe, general sales manager of the Sonora Phonograph Co., of New York, spent several days in Pittsburgh in conference with Mr. Miller. The latter is confident that the sales of the Sonora this Fall and Winter will be large, especially period models.

Open Sales and Display Rooms

A. B. Smith, Pittsburgh representative of the Granby Phonograph Corp., has opened sales and display rooms in the Pittsburgh Life Building, corner of Sixth street and Liberty avenue. Mr. Smith said that "a careful analysis of the field in

this territory proves to me that there is every reason to be an optimist and to confidently look forward rather than to regretfully look backward."

Boggs & Buhl Bubble Book Party

One of the pleasing affairs of the past month was the "Bubble Book" party given to over 2,500 children by Boggs & Buhl, the North Side department store. The party was given under the direction of Mrs. E. B. Harrington, of New York, who is associated with the Harry Sherwin Co., promoters of the Harper & Bros. "Bubble Books." A Columbia phonograph and the Magnavox were used. Henry Wood, of the Boggs & Buhl talking machine department, and Mr. Schwartz, of the firm's toy department, assisted in making the party a success. A large number of "Bubble Books" were sold. A number of children specially trained by Mrs. Harrington, who came to Pittsburgh several days before the party was given, made a hit with their songs and dances.

M. Weinburg Again at the Helm

M. Weinburg, manager of the Victor department of Spear & Co., is back at his desk again after a several weeks' stay in a hospital. The Spear talking machine department is one of the largest and most complete in the city.

Pennsylvanians Visit the Starr Plant

Organized by H. C. Niles, secretary-treasurer of the Starr Phonograph Co. of Pennsylvania, nineteen Starr phonograph and Gennett record dealers recently visited the Starr plant in Richmond, Ind. The party made the trip in a special car, and while at the factory were given a close-up view of the plant and its workings, especially the recording work in the phonograph department. Harry Gennett and Fred Gennett, vice-president and secretary, respectively, of the Starr Piano Co., were the proud hosts of the Pittsburgh delegation. Those who made the trip

were Lester Stewart, Phonograph Shop, Homestead, Pa.; W. C. Pifer, Keyser, W. Va.; Clark Jones and B. D. McMillen, Jones & McMillen, Beaver, Pa.; Jacob Schoenberger, Lechner & Schoenberger, Pittsburgh; George Minch and George H. Selzer, Minch & Selzer Co., Coraopolis, Pa.; W. T. Parker, Vale Summit, Md.; Harlan A. Horne, J. M. Hoffmann Co., Pittsburgh; E. J. Michael, E. J. Michael Piano Co., Pittsburgh; A. K. Smith, Punxsutawney, Pa.; L. M. Lytton, Burgettstown, Pa.; Roy Velock, Velock Music Co., New Brighton, Pa.; A. G. Leonard, R. E. Stone Co., McKeesport, Pa.; R. E. Williams, R. E. Williams Music Co., Greenville, Pa.; Andrew Tomasco, Black Lick, Pa.; H. H. Imhoff, Clarion, Pa., and F. A. Stewart and H. C. Niles, Starr Phonograph Co., Pittsburgh.

Increasing Vocalion Representatives

The Clark Musical Sales Co., wholesale distributor of the Vocalion phonograph, reports sales conditions good and the outlook as most satisfactory. Among the local Vocalion retail dealers are the National Phonograph Co., 633 Liberty avenue; Knobloch's, 1816 Beaver avenue, Northside; H. Mysels, 2017 Center avenue; the Markovita Drug Store, 401 Hawkins avenue, Rankin, Pa.; Tischler Bros., 142 East Main street, Carnegie, Pa.; Kaufmann & Baer Co. and Scott Co., East Liberty. Recent new Vocalion dealers are: A. Klein, 3705 Butler street, Pittsburgh; M. A. Madison, Ridgway, Pa.; A. McLaughlin, 1713 Murray avenue, Pittsburgh; D. O. Shaver and D. A. Waite, Altoona, Pa. The Pittsburgh offices of the Clark Musical Sales Co. are in charge of J. A. Pentz and Charles E. Stran, both well known to the trade.

The Greene Drug & Jewelry Co., of Dickinson, N. D., has purchased the stock of Victrolas and records of the McDonald Drug Co., and is now the only Victor dealer in Dickinson.

"MAGNET" DECALCOMANIE NAMEPLATES

FOR TALKING MACHINE CABINETS ETC.





Pamphlets with fac-simile illustrations and prices mailed on request.

SMITH-SCHIFFLIN CO.

149 Church Street New York City



SOLD BY
WALTER D. MOSES & CO.
Oldest Music House in VA and NC
103 E BROAD STREET
RICHMOND, VA.

SOLD BY
J. E. STRATFORD
AUGUSTA, GA.

? ? ? ? ? ? ? ? ? ? ? ? ? ?

The Burning Question ?

Does a Sheet Music Department Belong in a Phonograph Shop?

The Answer is ———
EMPHATICALLY YES

For the Following Reasons:—

1. Substantial profit—averages 50% on cost.
2. Minimum Investment—requires about \$100.
3. Frequent turnover—investment turnover, ten times annually.
4. Brings trade in your store for other merchandise.
5. Pays entire running expense of store.

To further substantiate our claim of the value of a Sheet Music Department, we can refer to hundreds of successful Phonograph Dealers throughout the country whom we convinced through our special Guarantee Offer.

Our Guarantee Offer

We will ship you an assortment of the latest and best selling hits. At the end of thirty days, you may return to us (charges prepaid) any unsold copies that are in perfect salable condition. In this way, all investment risk on your part is removed. You really start the department at our expense.

*Write for further particulars,
dealer's helps, display racks, etc.*

PLAZA MUSIC CO.

20 West 20th Street

NEW YORK CITY

STARTS SHELTON MOTOR CAMPAIGN

Shelton Sales Co., With Headquarters in New York, an Excellent System of Distribution—W. Gentry Shelton Is President of Company

The Shelton Electric Co., New York City, has instituted a strong campaign on the Shelton motor in its improved form. This motor, through a friction drive, electrically operates any phonograph. The motor is placed at the edge of the turntable on the top of the motor board and can be installed ready for playing in a minute's time. It is made for both alternating and direct currents and consumes only ten volts, which, it is well known, is a negligible quantity. It may be applied to either Edison, Victor or Columbia talking machines. Among the refinements found in the Shelton motor is an automatic switch and a permanent rubber wheel, which, it is claimed, will practically never wear out.

An excellent system of distribution has been accomplished, thereby permitting the maximum of service to the dealer. In the East the Shelton Sales Co. has been formed, with headquarters in New York City, and every Edison distributor is distributing the Shelton motor as well.

W. Gentry Shelton, president of the Shelton Electric Co., stated that there are over 25,000 satisfied users of the Shelton motor at the present time. Through the quality of the product and the efforts of Mr. Shelton and his associates and distributors it is expected that the number will grow at a remarkable pace.

NEW ASSOCIATION IN NEW YORK

Victor Luncheon Club Organized Into a Permanent Association—L. J. Rooney President

At a largely attended meeting of the Victor Luncheon Club, held at the Café Boulevard, New York City, on Friday, October 28, the Metropolitan Victor Dealers' Association was organized to take in those retailers located in what is termed the metropolitan district of New York. The officers elected at this meeting are: L. J. Rooney, president; Ernest Leins, vice-president; E. G. Brown, secretary, and A. Galuchie, treasurer.

The Victor Luncheon Club was organized some months ago for the purpose of bringing together the Victor dealers of New York and vicinity for the discussion of timely business topics. The luncheons have been well attended and have proven so interesting that it was decided to form a permanent association. Just what effect the new organization will have on the two existent associations made up of talking machine retailers in New York and vicinity remains to be seen.

CUSTOMERS' RECORD MEMO BOOK

Ideal Music Co. Distributes Clever Booklet Containing Record Lists, Blank Pages for Patrons' Memorandums and Calendar

E. V. Bragdon, of the Ideal Music Co., Victor dealer, New York City, has evolved a clever idea which acts as a reminder to customers of the records which they are particularly desirous of obtaining. Mr. Bragdon has had a number of small memorandum booklets made up which he mailed to his customers. The cover bears the Victor trade-mark and the following text: "Records I Want From the Ideal Music Co." On the inside cover under the heading "Standard Operatic Selections" are listed twenty-three such records, and on the back cover twenty standard selections are listed. The inside back cover contains a 1921-22 calendar and there are twelve blank pages in the booklet for the customer to list the records which he desires to purchase.

A GREAT ARRAY OF DEALERS

The number of dealers in Detroit, Mich., handling the Columbia line, totals forty-one. These dealers are, for the most part, very aggressive and they take advantage of all dealer helps distributed by the Columbia Co.

THE TALKING MACHINE WORLD SERVICE

Robert Gordon's Page -

A DEPARTMENT DEVOTED TO PROMOTING RETAIL SALES



Sell Through Your Store Window!

NOW that the shopping season is once more in full swing, it is more important than ever that attention should be paid to your window displays. It is not necessary to spend a large amount of money to dress up your window, as original displays will catch the eye of the passerby just as quickly as a costly window layout.

* * *

HERE is a window display which, if your window is in easy access of your store, will produce an excellent psychological effect that will result in big sales of your newest record hits.

Instead of stocking up your leading hits on racks, put them all into your window in piles. In order to give a larger effect, mount these piles on boxes covered with throws of velvet or other material which you use for decoration. If your stock of records is too small to make a good-size pile use other records for the bottoms of the piles. In front of each pile have a card giving the name of the hit. Across the front of the window, suspended by wires from the ceiling, should be a large card with the words "GOING—GOING—BUY TODAY." As you sell the records, the pile greatly diminishes. Pedestrians who look into your window will see the salesmen when they reach into the window to take another record from the top of the pile. There is something about the effect of this which stirs the public to action, as they see the pile getting smaller.

* * *

MOST every community enjoys out-of-town trade. Although a considerable amount of business is done by this out-of-town trade while they are visiting in the city, a still larger amount is done through the mail, after they return to their homes. If you sell records by mail you can arrange an effective display to attract these out-of-town customers, as they pass your store, which should later net you considerable sales.

Save a considerable quantity of envelopes which you have received from mail-order customers. Attach these at intervals of 12 inches to a strip of red crepe paper. Frame your window with this strip. In the center of your window, on a mount, place a package of records with cardboards, etc., just ready to be tied up for mailing. The parcels post tag should be visible on the package. A sign placed conveniently in the window should read: "We sell records by mail. Come in and ask for details."

* * *

THERE is a perpetual interest among us mortals to know what the other fellow is doing, or what he has. This gives you an opportunity to dress your window in an unusual manner and at the same time create sales of records. The window should be arranged as follows:

Insert three or four large upright signs, attractively lettered. One of these signs should be headed "The record collection of a Banker in this city." Then should follow a list of records, classified as dance records, popular records, instrumental records, etc. At the bottom insert this line: "How many of these have you got?" On the next sign, in the same way, list the records owned by a society woman, and the third sign should tell of the records a prominent builder prefers. This information you can secure by going to the individual and promising him that you will not disclose his name. He will, without doubt, be glad to let you make a list of the records in his library. You can continue this window display as long as you wish, frequently changing the type of individuals whose records you disclose. Other interesting subjects would be the editor of your local paper, a doctor, a prominent public official, a musician, a politician, a policeman, a football star, etc.

Add interest to your display by placing at the foot of each card some object which is characteristic of the person whose records are listed on the sign. For example, at the bottom of the banker's sign place a bankbook, stuffed with a few new greenbacks, and nearby a good cigar, with an ash tray and golf ball. With the society woman's sign use a decorated fan, a pair of long white gloves, a high-class inkwell with a quill pen stuck into it. At the base of the builder's card place a blueprint plan with dividers, rule and pencil.

There is a lot of human interest in this display, as people are always anxious to know what tastes, likes or dislikes the other fellow

has, and as they read these record lists they will note many records which they would like to have themselves.

Along the bottom of your window place a long sign reading: "We have all of these records in stock now. Come in and hear them."

* * *

A CROWD will stop and watch a moving window and it will also stop to watch anything mechanical. Here is a way to make up an attractive window which will make the crowd stop and at the same time help to greatly increase the work of your repair department.

Clear out one of your windows and then place in it a miniature repair shop, complete with a small bench and chair, also the necessary clamps, screwdrivers, etc., for a repair man to work with. Place your repair man in the window and let him do his daily work before the public for a period of six days. You should buy a blue denim coat for your repair man for this occasion, so that he will appear neat and trim, yet not overdressed. A series of signs should be placed about the window reading as follows:

"We do expert repairing." "We clean and overhaul your motor and make it like new." "Every talking machine needs overhauling at least once a year to give proper service." "An overhauling will make your motor run smoothly, increasing the reproducing accuracy of your machine." "We will call for your machine at your request." "Our service is guaranteed," etc., etc.

If you desire, build a rack for these signs, and then have your repair man every once in a while reach down for a new sign and place it on display. Such a window will make people stop, look, listen and act.

* * *

A PICTURE to the eye is always more quickly assimilated than a word picture. Again, often one is in a hurry and does not have time enough to stop and study your window. Therefore, if you can design a window which will catch the fleeting glance you will greatly add to its pulling power. Such a window display as the following has this advantage:

From a toy store or a local architect borrow a small model of a dwelling house. If possible, secure one with transparent windows so that the house can be lighted in the evening by an electric bulb. On the floor, about the house, arrange a green mat to resemble grass and with the use of sand build a little roadway and make other little touches which will give the spot a more real appearance. This set-up should be at the left of your window and at the right should be a cabinet model talking machine. From red cardboard cut a large arrow, long enough to reach from the top of the talking machine to the house. Suspend this in place by wires from your ceiling. Beside the talking machine place a chair or some other object with a rug and a lamp, so as to picture a small portion of a living-room. A small card, which should be placed at the front of the window on the floor, should read as follows:

"This machine belongs in your home. It will make every day a happy day."

* * *

A THANKSGIVING window bringing the warmth and friendliness of the occasion to the passerby may be arranged as follows:

Get a supply of colored leaves, either natural or artificial. String these on a black thread, tying the stems to the thread at intervals of 4 inches. Enough of these strings should be made to frame your window all around. Set a talking machine in the center of your window and let strings of the colored leaves radiate from it to the top and sides of your window. Place a low pedestal in the foreground. Cover it with dark velvet or crepe paper. On this place a large upright sign with the words

"MUSIC AND THANKSGIVING

The great artist, Nature, has given us an abundant harvest of the fruits of the earth. But far greater is the harvest of happiness, yielded by the artists of music—the greatest blessing bestowed upon mankind. Will there be music in your home on Thanksgiving Day?"

This sign should be in tones of brown, yellow and red to harmonize with your autumn leaves. On the floor, at the base of this sign, arrange some harvest fruits, such as wheat, apples, pumpkins, etc. Your electric light for illuminating the window at night should be covered with light brown, yellow or red crepe paper.

EDITOR'S NOTE—Mr. Gordon, who writes this monthly page, is also director of "The Talking Machine World Service." Mr. Gordon will publish on this page any good ideas submitted by you for the benefit of the trade, and also answer any questions you ask him concerning merchandising problems. Use this department as much as you like. It is intended to serve you.



THE BIG HIT FROM "TANGERINE" —
 A CATCHY MELODY YOU CAN'T FORGET
"Sweet Lady"
 Sung by JULIA SANDERSON and FRANK CRUMIT

ASK TO HEAR IT

"You can't go wrong with any 'Feist' Song"

PHOTOPHONE COMBINES RECORDS OF SOUND AND ACTION

Swedish Inventors Claim to Have Discovered a Photographic Record of Action and a Gramophonic Record of Sound Which Work Together, Insuring Perfect "Talking Films"

Swedish inventors and men of science believe that they have discovered the way to "talking films"—that is, means by which a photographic record of action and a "gramophonic" record of sound may work together to produce a single illusion. These means are rays of light, and the mechanism in which they work is called a "film photophone." The London Times has reviewed and prints what purports to be the first account of the new invention. "If I were to say," writes its correspondent, "that Professor Montelius, sitting by my side in the darkened garden of a laboratory near Stockholm, saw on a screen before us a moving picture of himself as he had appeared delivering a scientific lecture three days before, the interest would be slight. If I were to say that, while the screen was displaying the moving picture, certain sounds were assailing the ear purporting to be reproductions of the words of his lecture, nobody would be surprised. But when I say that, while the picture film was passing, we listened to his words, full-voiced, distinct in every difficult utterance...that these words were synchronized infallibly with posture, with gesture—interest will be awakened. What we saw was Mr. Montelius in his capacity as Royal Antiquarian and Director of the National Museum, at his lecture desk or moving freely about the platform, without thought of a camera or a receiver, and what we heard were his words in a reproduction so perfect that it was almost impossible to believe that Montelius was sitting, with silent lips, at my side.

"The achievement which we witnessed was no mere refinement of technique, no mere improvement of methods already invoked by other inventors. It accomplished itself through the employment of a novel instrument by an invasion of the regions wherein sights and sounds strive

to reach the senses of man. It was a pencil of light that had pictured the sounds, and a needle of light that gave them back. Or, rather, to write with accuracy, there was no needle about it—what we heard was, literally, a photograph of Montelius' lecture. Until now we have only seen photographs; in the future we may hear them. The new invention simultaneously films scenes and sounds. It transforms the vibrations of the voice into light waves, these into electrical impulses, which, controlled and utilized with great skill, return to the ear the original sounds in every shading."

The film photophone operator sets up in the neighborhood of his actors a double camera. Its two reels revolve on a common shaft. The record of one camera is the ordinary screened picture: The eye of the second camera, however, is not directed towards the actor, but gazes into a ray of light—a ray agitated by the actor's voice. How is the ray agitated? Across the end of a little horn, like a telephone receiver (which, in fact, it is) stretches a delicate diaphragm of rock crystal. Upon the silvery back of this diaphragm falls a slender shaft of light from an electric bulb. The shaft of light impinges on the diaphragm at an angle. It is reflected into the camera, which it enters through a narrow upright slit. So long as the reflector is at rest the ray of light will be reflected at a single constant angle, corresponding to the angle of its incidence. But if the reflector be agitated the ray will be reflected at constantly changing angles. Just as a boy, with a bit of looking-glass in his hand, writes words on the wall with the reflected sunlight, so the diaphragm, as it vibrates to the voice, writes with the light ray which it reflects, writes on the celluloid film as it moves through the camera, writes curves correspond-

ing to the sound waves which are agitating it. Were the diaphragm at rest the reflected ray would photograph itself as a straight band of white along the bottom of the moving film. But as the reflector vibrates the straight band becomes a silhouette of waves, of varied contour. This is the photograph of the spoken words.

"But how reconvert at will this phono-photograph into sound? How retransmogrify these pictured vibrations into resonant vibrations? There is a substance, an element known as selenium, which possesses the curious property of resisting the passage of electricity in proportion to the degree of light in which it is bathed. The photophone invokes the aid of this mineral. In an amalgam with other substances, which make possible practical utilization of its curious property, selenium is made the controlling feature of a device, in the nature of a light-electric cell, which augments or diminishes its own resistance to an electric current in accurate response to the strength of the light that falls upon it. It is upon this selenium cell, not upon a screen, that the film of the voice is projected. The cell is incorporated in an electric current, leading (eventually, not quite yet) to a telephone transmitter. As the current passes through it this cell controls and modifies its strength to an exquisite degree, as there falls upon it the flicker of the lights and shadows of the sound film. The electric current, as it emerges from the selenium cell, is vibrating in precise correspondence with the vibrations of the light waves, and with the sound waves of which they are the reproduction.

"But this current is weak; it would not operate the speaking diaphragm of a telephone. It will be fortified by 'audiones'—high-vacuum amplifiers. Thus amplified, if desired, up to several thousand times its original strength, the current—now freighted with the enriched vibrations of the voice—is conducted to the horn of a loud-speaking telephone, and delivered—a reproduction, instantly recognized, of the utterance of

FREE OFFER



This attractive metal and glass counter case given free with 3 cartons at \$5.50, total \$16.50

MAGNEDO

THE OLDEST AND FASTEST SELLING

TEN-PLAY NEEDLE

Seven years of constant advertising has developed an ever-growing demand from all over the country for MAGNEDOS solely because of merit.

Magnedos offer substantial profit to Jobber and Dealer.

Retails at 10c. a box

Dealer's price \$5.50 carton of 100 boxes

MANUFACTURED BY **SUPERTONE NEEDLE WORKS** 18 WEST 20th STREET NEW YORK



Senate Votes to Free All Musical Instruments From Excise Taxation

Agrees to Proposal of Senator Frelinghuysen of New Jersey to Strike Out Section of Revenue Bill Providing for Excise Taxes on Musical Instruments

WASHINGTON, D. C., November 4.—Musical instruments of all kinds, as well as rolls and records, will be entirely free from excise taxes in the new Revenue bill, as drafted by the Senate, according to the action taken by that body Monday, when by a viva voce vote it agreed to the proposal of Senator Frelinghuysen, of New Jersey, to strike out that part of Section 900 of the pending Revenue Revision bill dealing with musical instruments. There were only about three dissenting voices to be heard as the presiding officer called for the yeas and nays, one being that of the Senator from North Dakota, Mr. McCumber, who had previously announced that the repeal of the tax would cause a loss to the Government of approximately \$12,000,000.

The Republicans were roundly scored by Senator James Reed, Democrat, of Missouri, for their action in lowering taxes on sporting goods, chewing gum and similar commodities—non-essentials—and seeking to retain the levies on musical instruments, auto trucks and works of art.

Just previous to taking action looking to having the tax repealed Senator Frelinghuysen assured the Washington correspondent of *The World* that the Senate would agree to his proposal. This is one of the few amendments in which the Republicans and Democrats joined hands, showing that all of the Senators were in sympathy with this move to relieve the industry of the tax burden.

This is borne out by the fact that while the clerk of the Senate was preparing to read the amendment offered by Senator Frelinghuysen, Senator George Moses, of New Hampshire, was on his feet endeavoring to offer an amendment verbally which had the same action in view, and there were others on both sides of the Senate Chamber seeking recognition, ostensibly with a similar object in view. As stated, there were no remarks expressed against the repeal.

The Frelinghuysen amendment, on which action was taken, read: "Strike out paragraph 4, page 197, lines 8, 9, 10, 11 and 12." The paragraph so stricken out reads: "4. Pianos, organs (other than pipe organs), piano players, player-pianos, graphophones, phonographs, talking machines, music boxes, and records used in connection with any musical instrument, piano player, player-piano, graphophone, phonograph, or talking machine, 5 per centum."

The 5 per cent tax on sporting goods was ordered repealed by a vote of 31 to 30, showing the difference in feeling toward that paragraph as compared with the provisions affecting musical instruments.

Following the evident failure of the Smoot proposal for a manufacturers' sales tax, followed by the rejection of the Calder amendment by

the Senate, there was a bill introduced by Senator Frelinghuysen, who comes from the State that produces the bulk of talking machines of the country, to reduce excise taxes on talking machine records from 5 to 3 per cent.

Later on Senator Frelinghuysen introduced the present amendment, which had the endorsement of Senator Edge, also of New Jersey, freeing all musical instruments from excise taxes. The adoption of that amendment by the Senate is to be regarded with great satisfaction by members of the music industry who have taken such an active interest in the efforts being made to lift the excise tax burden.

Although the direct action of the Senate was on the amendment introduced by Senator Fre-

linghuysen, the fact that the amendment to eliminate the excise taxes on musical instruments was adopted without a roll call, that it had the direct support of the great majority of the Senators and was opposed by only three or four is accepted as proof of the widespread effect of the strenuous work carried on by the members of the music industry throughout the country to secure relief from such taxes, and particularly to the influence of the great music advancement work that has been carried on in all sections for several years past. That the trade is appreciative of this fact is indicated by the number of congratulatory messages received at the offices of the Music Industries Chamber of Commerce.

There were sixty-five Senators present when the vote was taken, a rather unusual attendance, and that there was practically no opposition is significant, for when it came to voting on the lifting of excise taxes from sporting goods a roll call vote was demanded and only thirty-one voted in favor of eliminating the tax.

The Frelinghuysen amendment is to be credited in a large measure to prominent talking machine interests.

To Prepare for the Victor Christmas



HIS Christmas will be another Victor Christmas. Ere the holidays are over, thousands of Victrolas will be placed in many new homes throughout the country.

We have always, as jobbers, tried to anticipate the needs of our dealers, and have always helped them towards securing their share of this Christmas business.

Our record in the past is a guarantee of our desire to serve you more adequately than ever during the coming holiday season.

CURTIS N. ANDREWS

Victor Wholesaler

BUFFALO, NEW YORK

THE FILM PHOTOPHONE THE LATEST

(Continued from page 110)

the original speaker. Delivered, too, in absolute synchronism with the simultaneous picture. The synchronism is perfect, because it is automatic; the picture film and the sound film were made on, and are projected from, reels turning on the same shaft and on celluloid controlled by identical perforations.

"If the film photophone has any inventor, he is Sven Alson Bergland. But the processes necessary for the achievement have involved so much of mechanical and electrical as well as chemical knowledge and skill that Mr. Bergland, for all his twelve years of industrious application, can only be regarded as the leader of a band of inventors. Nor would this band have been successful in their pursuit of the secret of synchronized sight and sound without the support of the old Swedish family of Frestadius."

IMPROVING TRADE CONDITIONS EVIDENT IN NORTHWEST

Brunswick Officials Optimistic—Many New Dealers Listed—S. D. Andrews' Pertinent Review—Beckwith-O'Neill Co. Tells of Victor Demand—Edison Trade Active—Other News

ST. PAUL AND MINNEAPOLIS, MINN., November 7.—It is impossible to convince the Northwestern wing of the Brunswick-Balke-Collender Co. that the talking machine business is dull, for the entire staff is busier than ever and the results are better than ever. George M. Nye, manager of the phonograph end, states that 1921 will show up better than 1920 in every way and the dealers are satisfied with their returns. The Jenson Furniture Co., in St. Paul, a new venture, will take on the Brunswick line. A number of Twin City merchants have applied for permission to handle the Brunswick phonographs, but, for obvious reasons, it is not advisable to have too many dealers in the field. Brunswick records are given continuous and effective advertising by Roy Swanson, manager of the exclusive shop in St. Paul. He has a big record disc, over six feet in diameter, out in front and this disc has an illuminated center, from which the name of the record is

flashed in the faces of the pedestrians, the name being changed constantly.

If the banks, that is, the rural banks, were in position to finance the local music dealers it would be possible to get some very nice trade, says Sewell D. Andrews, of the Minneapolis Drug Co., distributor of Sonora machines and Okeh records. Under the present conditions the rural dealers are obliged to sell on extended terms, or they cannot sell at all, but the local bankers are in no position to extend any help to such transactions. The result is that jobbers are often obliged to refuse orders because the accounts must be carried too long for sound business practice. Mr. Andrews notes an increased demand for period models.

W. L. Sprague, Northwestern manager for the Columbia Graphophone Co., is on the road again, this time traveling with his roadmen in North Dakota. This is his way of putting his hand on



No. 35861
**HOLLY
WREATH**

Why pay \$1.00 each year for Holly Wreaths while my natural prepared Holly Wreaths No. 35861 for \$1.00 last year ten to twenty years at cost of \$.05 to \$.10 per year?

My XMAS CATALOGUE No. 35

with illustrations in colors of Artificial Flowers, Plants, Trees, Hanging Baskets, etc., mailed FREE FOR THE ASKING.

FRANK NETSCHERT

No. 61 BARCLAY ST., NEW YORK, N. Y.

the pulse of the trade and he finds it very effective in stimulating the interests of the dealers and his road salesmen. The Columbias are going out very rapidly in all parts of the territory.

Victrolas continue to be in popular demand, according to E. F. O'Neill, of Beckwith-O'Neill Co. There has been marked improvement in orders in the past sixty days and the company's reserve stocks are much lower than they were ninety days ago. Two of the bright stars of the Educational Department of the Victor Co. have been shining in the Northwest recently. These luminaries are Miss Fannie R. Buchanan and Miss Donzella Cross. Miss Buchanan has been talking to teachers' institutes and conventions in South Dakota and is now on tour in Minnesota. Miss Cross was one of the most entertaining speakers at the annual meeting of the Minnesota Educational Association, at Minneapolis, November 3-5, and has dates with the North Dakota Educational Association at Fargo, November 21-23.

Milton Lowy, manager of the Minnesota Phonograph Co., still maintains that 1921 will be a bigger year for Edison phonographs in Minneapolis than was 1920. The work is a little harder, he confesses, but persistency counts in the music trade as well as in other lines of endeavor. The wholesale demand for Edisons continues generally satisfactory in view of the various economic handicaps.

NICHOLS & FROST'S NEW HOME

Fitchburg Dealers Occupy Spacious Quarters on Main Street—Handle Victor and Columbia

FITCHBURG, MASS., November 2.—Nichols & Frost, which is a widely known establishment in this city, is now in a new location, having lately taken over the old B. L. Rich music store on Main street. The firm is specializing in the talking machine line and with the Brunswick and the Victor, which latter machine it has lately taken over, the house is doing a rapidly increasing business. G. Herbert White, who is a conspicuous factor in the business of the establishment, was one of those attending the New England Music Trade Association banquet in Boston a week or so ago. Fred Warren, the manager of the store, which also handles sheet music, is one of those keen business men who is constantly on the lookout for new ideas that will help to legitimately attract business.

The firm of A. J. Freiman, Ltd., Ottawa, Canada, retail talking machine dealer, was recently incorporated with a capital stock of \$1,500,000.

The SPHINX MOTOR

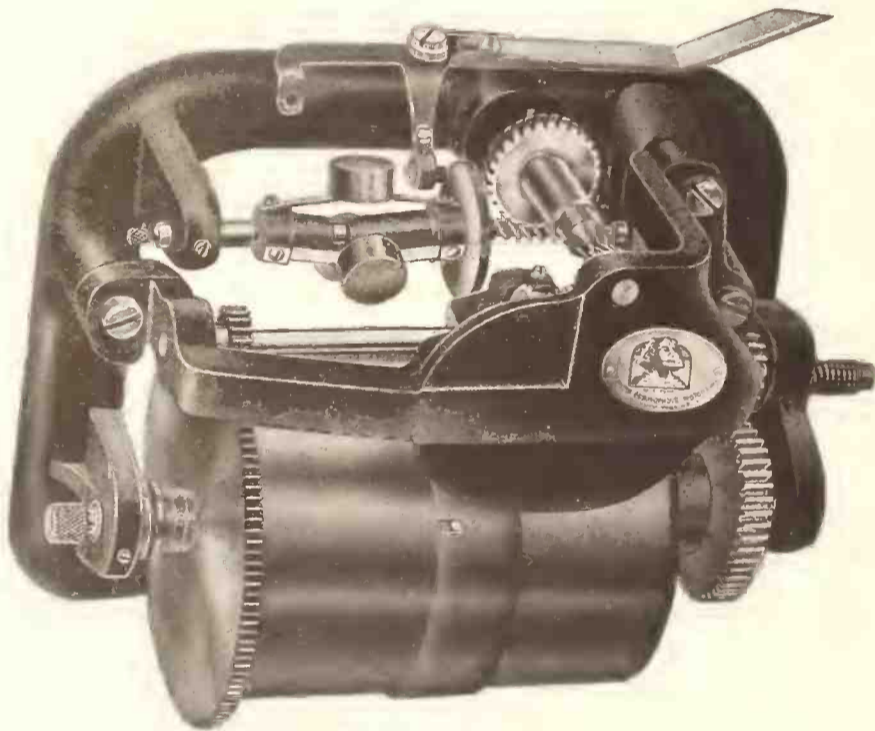

Motor Refinement

*Better Designed
Better Built
Better in Operation*

SPHINX GRAMOPHONE MOTORS, Inc.

21 EAST 40th STREET, NEW YORK

NEEDLES

WE MANUFACTURE

Diamond needles for Edison
Sapphire needles for Edison
Sapphire needles for Pathe
in stock ready for delivery

MERMOD & CO., 874 Broadway, N. Y.

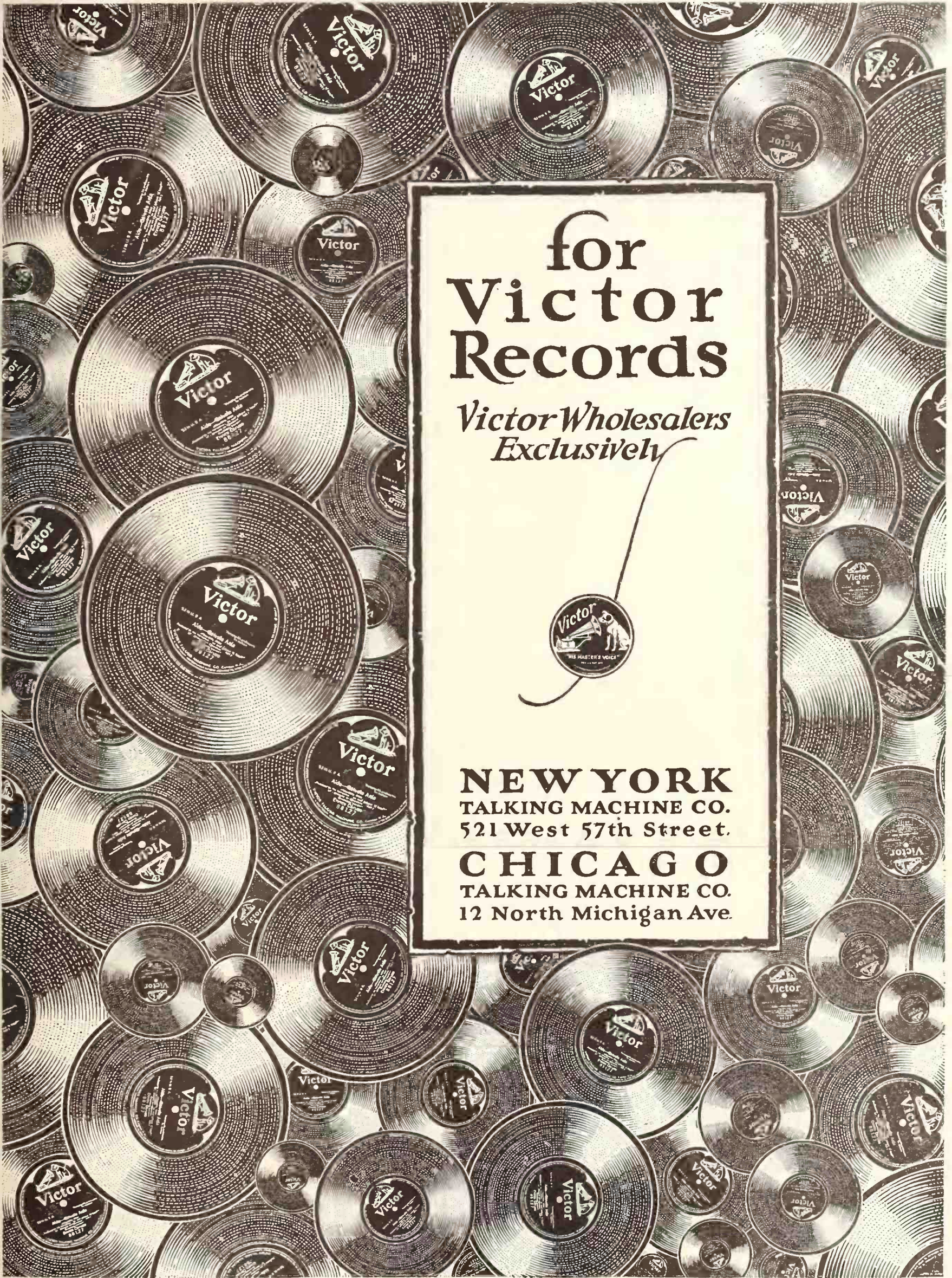

for
Victor Records

*Victor Wholesalers
Exclusively*



NEW YORK
TALKING MACHINE CO.
521 West 57th Street.

CHICAGO
TALKING MACHINE CO.
12 North Michigan Ave.

Mid-West Point of View

WESTERN DIVISION OF THE WORLD, CHICAGO, ILL., Nov. 10, 1921. TRAVELING men, from North, South, East and West, are united in proclaiming that the talking machine business is decidedly on the mend. Of course, it may as well be admitted that the talking machine business never did know the extreme straits of depression, the Slough of Despond, to which some other industries found themselves reduced during the Spring of this year. But the conditions at times looked bad enough, and now that the clouds are really so plainly lifting that all can see the sun for themselves we naturally feel very much better about everything. From all sides come reports of improvement, reports which, allowing for any exaggeration, are nevertheless far too definite to admit of any misunderstanding as to their substantial accuracy. And among all the other possibilities of this state of affairs, which we perceive with so much pleasure, there is one which, in our opinion, stands up above all others. It is that the manufacturing, jobbing and retailing concerns which have come through the storm in safety—and this means the very great majority of them all—were principally the old-established houses, composed of men who know the business, have been in it for years and neither hope to get rich quick nor think of putting forth a product without merit. These houses are stronger to-day than they have ever been, and their present condition is a complete demonstration of the truth that the talking machine industry is neither temporary nor unstable, but rests upon the firm basis of natural and normal human desire for the most compact and comprehensive of all means to music. The talking machine industry has triumphantly demonstrated its right to survive.

The
Clouds
Lift

SOMETIMES one can give point to an argument by a single illustration better than by oceans of talk. When anyone wants an illustration of the power and prestige of the piano industry in the Middle West it is customary to refer to the Four Piano Corners of our city, to the four great buildings which guard the angles of the Jackson-Wabash crossing. The Cable Company, the W. W. Kimball Co., Lyon & Healy and the Steger & Sons Piano Mfg. Co., each housed in its own splendid temple, dominate this particular part of Chicago's Loop in a manner inescapably complete and impart to the music industry of the whole city a dignity which otherwise could never belong to it. And when we say "music industry" we wish to distinguish from merely the piano industry. For the great institutions which bear such witness to the commercial importance of music in Chicago and the mid-West owe no little of their power to the influence of the talking machine. The Victor business done in the retail stores of Lyon & Healy and the Cable Company alone would in itself be enough to satisfy the legitimate aspirations of many a jobber looking for a retail connection settled in repute and steadily growing in turnover. And the other two great houses we have mentioned, which face each other on the opposite side of Wabash avenue from Lyon & Healy and the Cable Company, they too have carved out a place for themselves in the talking machine industry, a place equally admirable. Each of them has gone forward and worked out an original product, bringing to bear upon the task the accumulated experiences of years of piano making, and each has made a talking machine which reflects the highest credit upon the art of sound reproduction. Now all these houses are increasing the amount and intensity of their interest in the talking machine business, which tells of its stability in the mid-West.

To these remarks may be added the further and equally pertinent remark that we have reached the end of the underfinanced phase of our industry. Those who undertake to-day to come into the manufacturing field must be equipped with ample capital resources and with ample experience. They must know the industry from every aspect. The time has gone past when amateurs could succeed. But this does not mean to say that newcomers are not to be welcomed.

Welcome:
To the
Fit Only

On the contrary, they are always welcome, but they should know the nature of the game they propose to play. We want to see new manufacturing corporations devoting themselves to talking machines, records and accessories, but we do not want to see groups of men coming into the industry beaten before they start.

It is a curious and very suggestive fact that when an industry has been going through a period of disturbance it is sure to blossom out with a whole crop of new ideas, new inventions, suggested improvements and novel styles. The reason is, of course, not far to seek. When times are very easy, when sales are coming in faster than they can be cared for, there is neither time nor inclination for changes in factory methods. The one great need is to get out the goods as fast as possible, leaving changes for some time later, when they can be attended to in a proper way. The later time usually comes in due course and then we see a totally different state of affairs. The task of selling ceases to be play and becomes hard work. The old game no longer attracts and something must be done to bring the people in. It is then the ingenious ones get to work. New sales methods are devised and new publicity methods thought up by sales managers. Just as powerfully, also, the brains of the inventors find themselves stimulated and we have a crop of new technical and mechanical, musical and constructional ideas, some of which always are found to possess elements of permanence. To a large extent the principle here set forth is in operation to-day. We find that the amount of real fundamental brainwork being done throughout the industry vastly overshadows anything thought of a short time ago. Not only are new ideas being put forth in salesmanship and merchandising, but there is everywhere an evidence that factory methods are being quickened and new notions canvassed with a pertinacity worthy of the highest praise. We hear constantly of better ways of making this or that thing, of better material put into a tone arm or a tone chamber, of more careful assembling, of closer attention being paid to accuracy in workmanship, of finer reproduction effects attained by some record process recently devised. It is all to the good. It all shows that the industry is proving itself worthy of the faith of those who have believed in it. We for our part believe in it now more confidently than ever.

'Tis
an Ill
Wind

THE general opinion of those record men who watch most carefully the signs of the times seems to be that the sentimental ballad is coming back and that the day of the inane words cannot much longer be carried to success through the sole agency of a catchy jazz tune. Of course, the catchy tunes are as much wanted as ever they were, which naturally leads to the thought that it would be a good idea to put less emphasis on the words and more on the music in most of these cases. So very often it happens that a tune is quite ideal for one of the popular dances and would be used in large quantities for this purpose if the tune itself were the prominent element in the reproduction. Now, most people like to buy a popular record for both the words and the music. They may laugh at the inane words because—well, because they like inane words, one supposes—but they want still more the tune. Now, when the accompaniment is killed to emphasize the words the record loses in value, and hence in popularity. Cannot some way be found of adjusting the balance?

Words
and
Tunes

FINAL note for November: There is every possibility of a definite shortage of machines and records before Christmas is many weeks nearer. Retail men may do worse than take note of this fact and act accordingly. They will oblige the manufacturers now and the manufacturers will then be able to oblige them later on. Which will make it mutual. This is a timely and important admonition which dealers should take to heart. If they fail to keep in touch with their jobbers, and through them with the manufacturers as to their needs, there is danger of their suffering later on.

Stop:
Look:
Listen

From our CHICAGO HEADQUARTERS

REPUBLIC BLDG., 209 SOUTH STATE ST TELEPHONE WABASH 524

EDWARD VAN HARLINGEN

WILLIAM BRAID WHITE

EUGENE F. CAREY

ARTHUR E. NEALY

A. SNYDER

CHICAGO, ILL., November 8.—In making our rounds throughout the trade in Chicago during the past two months we have been told by many dealers, and have seen the proof of it ourselves, that business is on the up-grade. Possibly, it is nothing yet to get excited over. Nevertheless, the improvement is there. Toward the latter part of October and the first part of November more activity than heretofore was noticeable. The dealers are almost universal in their assertions that they are getting rid of more goods and that their collections are easing up considerably. These dealers claim that the cool weather has been the means of ushering in this activity because it makes people stick closer to home. This has always been true in the past and is simply a case of history repeating itself.

With the wholesaler the story runs the same. They are putting on more help, especially in the traveling forces, and the travelers are doing good work, as may be judged from the orders they are sending back to headquarters. There is every reason to believe that there will be more or less of a shortage of many of the well-known makes of talking machines this year and this will be brought about by reason of the forced idleness of manufacturers for months past. In the other years, when business slowed up during the Summer months, the manufacturers went on building machines and prepared for any demand that might arise in the trade during the Fall and Winter months. But this year things were different. It was necessary for the manufacturers to curtail expenses in every way; then, again, the market for raw materials was so unsettled and prices were so topsy-turvy that the manufacturers were forced to sit back and wait. Hence, the posi-

tive possibility of a machine shortage this Fall.

For the above-stated reasons it would be well for the dealer to prepare for any emergency during the coming holidays by anticipating his wants early. In turn, the encouragement exhibited by the dealers at present should stimulate the manufacturer, who, in turn, must increase his output.

It seems that the better qualities of goods are selling here nowadays. The price question seems to be waning, insofar as the public is concerned, as there are very few purchasers who question whether there is a possibility or not of prices being lowered. The public seems to have taken it for granted that the bottom has been reached, and this is particularly true, with the exception of such items as certain foodstuffs, not forgetting rents. Clothing and furniture have found their levels. Buyers are satisfied and will, therefore, not wrangle over prices as they did at the beginning of the year.

The greatest demand has been for console types and portable machines, but the cabinet styles seem to be coming back. For a while there was practically no demand for cabinet styles.

In the record business the center of the stage is held by dance and popular song music, and this is also true with regard to sheet music and player-piano rolls which many of the dealers are now handling. The accessory business is still holding its own and, lately, more or less activity was added to the trade by the introduction of various mechanical novelties which are operated by being placed upon the record while the machine is played.

The Futility of Statistics

A young man came into The World office the other day in search of information regarding

talking machines—about the numbers produced, the relation of cost to selling price, the character of distribution, the number of instruments made and sold, and all that. He was a very fine chap. He took a real interest in his work. He knew what he wanted and The World office was only too glad to aid him. Now, there is seldom a vacancy in the Chicago World office. It is a matter of actual demonstration that it is hard to kill us off, but if any one of us should be suddenly transported to the blue some day this young chap, provided he is not engaged at the time, can get a job here.

But the very pleasant time we spent with him brought to our minds the futility of statistics. They represent so little. For instance, we have one very high-grade machine in mind whose influence in the trade cannot be gauged in any way by its actual sales. Lots of people have bought other machines because of the presence of this one machine in the market. They would prefer it, but cannot buy it because of its price, yet they have been educated to a desire for a talking machine by this very high-grade musical instrument. On the other hand, the reverse is also true. There have been any number of old-established machines sold because of the presence of new machines on the market. Before the business debacle came twenty salesmen, representing different retail concerns and different machines, would visit the people in a comparatively small city to talk machines, where formerly there were only three or four to do that. Consequently, people became educated to the talking machine proposition, but when they got ready to buy many of them would revert to

(Continued on page 117)

AT LAST—A PERFECT RECORD REPEATER

Now Ready for Delivery



Retail Price \$2.50

Some Remarkable Sales Records

Customer Buys Ten Repeaters

When the first Geer Record Repeaters were offered for sale a well-known Chicagoan purchased one for trial. A few weeks later this same man came to our factory and placed an order for ten more repeaters, saying he "wished them for his friends."

Sold Out in Five Days

The Fenton Music Company of Chicago, one of the first stores to handle the Geer Repeater, sold 24 repeaters, their first order, within five days.

At Pageant of Progress

At our booth at the Chicago Pageant of Progress small cards were handed out to visitors. Hundreds of orders were placed at that time and card orders are still drifting in from all parts of the country. This proves the very ready demand for Geer Repeaters.

Read this letter from the Wade Talking Machine Co., Chicago, Ill.

Walbert Mfg. Co.,
925 Wrightwood Ave.,
Chicago.

"We are pleased to advise you that after making a test of eight hours a day for two weeks, we decided to use your record repeater in our show windows as an attraction, with the result that it has kept large crowds before our windows continuously, resulting in sales of fifteen to twenty-five repeaters a day, and a very material increase in our sales of dance and instrumental records."

Very truly yours,
W. H. WADE, Pres.,
Wade Talking Machine Co.

The Wonderful New Geer Record Repeater

THIS repeater fits every type of phonograph with a free swinging tone arm. It repeats instantly and as often as desired. It protects the record, the needle and the instrument, and is as simple to use as a record.

It is proving a remarkable seller owing to the enthusiastic praise given it by purchasers to their friends. It is also stimulating sales of records and phonographs.

Write for our package of three repeaters (Price \$4.75, post-paid) for demonstration purposes, giving name of your jobber.

WALBERT MFG. CO.

925 Wrightwood Avenue

Chicago, Ill.

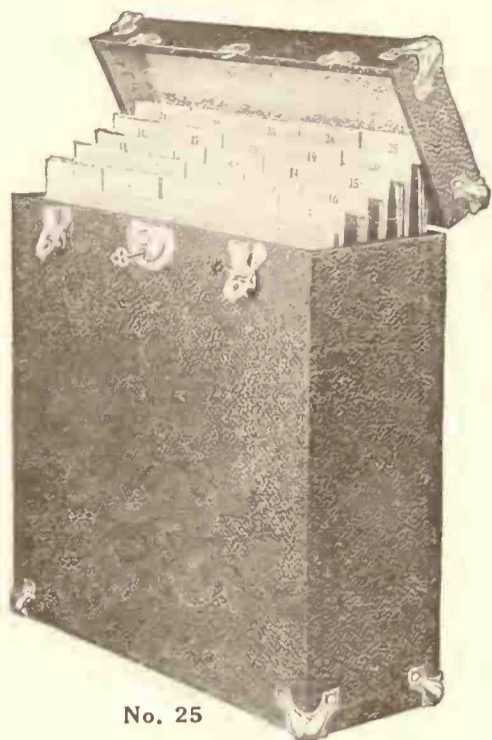

No. 25

Record Cases

At New, Low Prices

Specifications

Strong but light in weight; nickel-plated corner protectors, lock and catches; covered with black leatherette cloth; equipped with card filing system and index; easily carried; handsome appearing.

We advertised these cases in one of the trade papers, and within two weeks every case was sold.

Because of this great volume of business, we have been able to secure a lower price on our new supply. We are passing this reduction on to the trade.

A Big Help to Merchants

Every talking machine dealer needs these cases to carry on his own business. The up-to-the-minute dealer no longer waits for customers to come to the store; he goes out to their homes—with his latest records. Carry them in one of these strong, light-weight cases. Get one for each of your outside salesmen; it prevents breakage of records. It is easy to carry, and it impresses the customer as business-like, because it is efficient.

Sell Them, Too

A great number of people must have the Record Carrying Case. Sell them to every owner of a portable talking machine. Just the thing for motorists, campers and picnickers. It is excellent, too, for school and recital work.

Two Sizes

Record Carrying Case No. 25 is a very handy size. It holds twenty-five records, the average number released each month.

Suggested list price \$ 2.50
Merchant's price . . . 1.50

Record Carrying Case No. 50—A larger case, with room for fifty records. Best for concerts and recital work.

Suggested list price \$ 4.00
Merchant's price . . . 2.40



No. 50

LYON & HEALY

Victrola Distributors

CHICAGO

FROM OUR CHICAGO HEADQUARTERS—(Continued from page 115)

the old machines, whose names had become household words.

There is in all trade a moral factor which must be accounted for, but it cannot be gauged by statistics. The same thing is true of costs. One man with the same overhead may sell many more machines than another, but the first is perhaps only selling machines, while the other may be building up a prestige which will be an actual asset for many, many years. We are not disparaging the man who only sells machines, but he who puts money and effort into name and quality gets something that the other man does not get. It all comes back to the fact that there is no such thing as an average. That is, an average that means anything. The writer loves to recall a story once told to him by a distinguished Government official. The man told him of a friend of his in an Eastern city who had two sons. One was knock-kneed and the other bow-legged. One day a man consoled the parent of these twisted twins because of his affliction and that of his sons. The man simply straightened up and said: "Well, I guess my boys will average up as straight as any kid in town." And there you are.

Thank Heaven!

At last there seems to be a ray of light athwart the jazz gloom with which we have been covered. It looks as though we were going to have a return to the fine old topical songs of the years of yore, the songs with very popular, very humorous, but very musical tunes, with lyrics very popular, very humorous and really clever. These lyrics were often of a kindly satirical nature, like the classics with which the operettas of Gilbert and Sullivan were full. For example, "The Old Town Hall" and the "Old Swimmin' Hole" may not exemplify any high degree of refinement of lyric or technical accuracy of musical composition, but they mark the emergence from the jizz-jazz-juzzy flood of the past few years.

It is time something happened. They have been jazzing "Lead, Kindly Light." They did not call it that, they simply "marimba-ed" it. It may possibly be that somebody is able to get nearer to his God via the jazz route than via the old-time way. Maybe people have come to appreciate "Lead, Kindly Light" through a ting-ting-elized version when they would not have become familiar with it through the unadorned stately music to which it was originally written. It is very true that many people became familiar with "The Spring Song" and "Melody in F" through hearing them jazzed, but they probably gained the idea that Mendelssohn and Rubinstein were a firm of second-hand clothiers down on South Clark street. At the same time we believe that it would be better for us hereafter to have both our religion and our fun straight—not mixed. No one is saying anything against syncopation. It is a legitimate musical form. To its merry wiggle the world goes around, but let us have a time and a place for everything. Let us enjoy syncopation in its use—not its abuse. Let us enjoy our religious epics in their use—not their abuse.

Unquestionably the ballad is coming back. Furthermore, the abolition of the saloon has had a powerful influence on music. Many suggestive titles and vile lyrics would never have been perpetrated if it had not been that they were written primarily for the saloon and only leaked out into the street. Whatever may be our individual opinion on the total elimination of the cup that cheers and causes fears of snakes and pink-eyed lizards we certainly have nothing to lose, but everything to gain, when prohibition doth reign.

South Shore Shop Remodeled

The South Shore Music Shop, at 6853 Stony Island avenue, of this city, has just been completely remodeled. Alterations have been carried out throughout and three new demonstration booths have been built. This shop was started about a year ago by H. D. Buchanan, and in the short time it has been in existence has managed to build up an extensive clientele.

The location of this store is in that part of the South Shore district which a few years ago was nothing but prairie. To-day it has grown into one of the most thriving little business sections in the outskirts of Chicago. The South Shore Music Shop handles the Brunswick line exclusively.

Deckert Succeeds Williams

The Cable Piano Co. made the announcement this week that C. E. Williams, who has had charge of its Aurora, Ill., branch, has resigned. This position will be temporarily filled by H. K. Deckert, who goes to Aurora from the Chicago headquarters.

New Incorporation

A new concern which will manufacture and deal in talking machines and pianos in this city has just been incorporated. The news was

given out by Peter Tapper, who with his sons, E. F. R. and H. C., conducts a retail establishment at 2164 Lincoln avenue. According to Mr. Tapper, Sr., the new concern will make talking machines and pianos under his personal supervision. The amount stated in the incorporation papers was for \$50,000. Mr. Tapper, Sr., is well known in the piano world. For years he held a responsible factory executive position with one of the largest concerns in the West.

Enlarge and Decorate Store

Messrs. Nathan & Tobia, who conduct the University Brunswick Shop at 1203 East Fifty-fifth street, have recently enlarged their store and redecorated it throughout. They have installed six new sound-proof demonstration booths, which are treated in imitation ivory, and

(Continued on page 118)

The Oro-Tone

QUALITY FIRST

Just Say

"Send Samples On Approval"

For the Edison

No. I-E ORO-TONE

For Playing All Records on the Edison

Reproducers Fitted With Special Oro-Tone Diaphragms

Attached in a second. Needle retains perfect center in playing either hill and dale or lateral cut records. **TONE QUALITY**—Full, rich and glowing, with great carrying power and absence of metallic shrillness and surface noises.

Retail Price, Nickel Plated, \$7.50. Highest Grade Gold Plate, \$10.50.

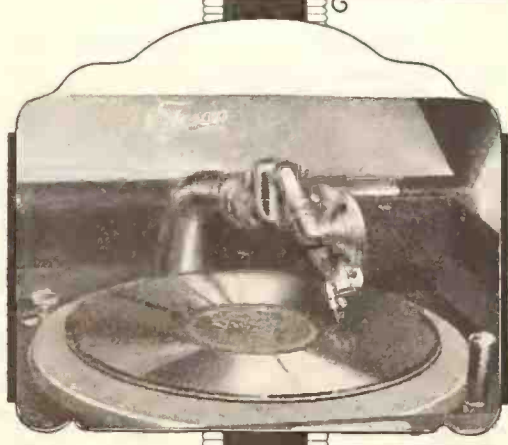

For the Victor

No. LS-V ORO-TONE

For Playing All Records on the Victor

Reproducers Fitted With Special Oro-Tone Diaphragms

Attached in one second. Needle retains perfect center in playing either lateral or hill-and-dale cut records. **TONE QUALITY**—Deep, rich and mellow, with great volume, eliminating thin metallic tones and surface or needle noises on the records.

Retail Price, Nickel Plated, \$6.50. Highest Grade Gold Plate, \$9.50.

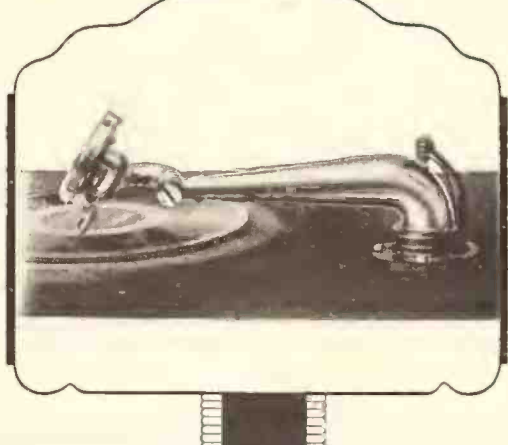

For the Columbia

No. I-C ORO-TONE

For Playing All Records on the Columbia

Reproducers Fitted With Special Oro-Tone Diaphragms

Attached in one second. Needle retains perfect center in playing either hill and dale or lateral cut records. **TONE QUALITY**—Rich and musical with splendid volume and definition. Surface or needle noises practically eliminated.

Retail Price, Nickel Plated, \$6.50. Highest Grade Gold Plate, \$9.50.



SEND FOR

Copy of the "Oro Tone" Illustrating the Complete Oro-Tone Line

The Oro-Tone Co.

QUALITY FIRST

1000 to 1010 GEORGE STREET
CHICAGO, ILLS.

FROM OUR CHICAGO HEADQUARTERS

(Continued from page 117)

are comfortably fitted up with furniture suggestive of home life. The lighting effects are so arranged that the customers may listen to records either by subdued indirect or bright direct lights, as they desire.

Wilson Broadway Music Shop Moves

The Wilson Broadway Music Shop recently moved from 1140 to 1142 Wilson avenue. This is one of the oldest concerns on the North Side of Chicago, and is located at the Wilson avenue terminal branch of the elevated railroad. The location is an extremely busy one, both night and day. The change of location gives this company about 66 2-3 per cent additional space and permits an increase in the number of demonstration booths. This concern handles various lines of talking machines and records in both a wholesale and retail way.

Business Increases

The retail business of the Central Music Co., at 608 West Chicago avenue, has grown to such an extent that, according to J. Fageron, the proprietor, it has become necessary for him to take on more space. He accordingly set about to increase the effective size of his establishment and has added six new booths, each of which measures eight by nine feet. He has also redecorated the interior throughout. The color scheme is carried out in cream and old rose, with French paneling on the walls.

Mr. Fageron has been conducting a talking machine business for the past four years and also conducts a retail shop at Forest Park, Ill., which is known as the Forest Park Brunswick Shop. Both are exclusively Brunswick.

Joins the Brunswick Sales Force

Arthur L. Fram, formerly connected with the talking machine department of Marshall Field & Co., is now associated with the general sales department at the Brunswick-Balke-Collender headquarters in Chicago.

Artistic Victor Calendar

The Reincke-Ellis Co. has just announced a 1922 calendar for Victor dealers that is meeting with considerable favor. In this calendar the picture (which may be chosen from several illustrations) is a home scene showing Victor products in use and combining human interest with intensive publicity value. The picture is reproduced by a new rotogravure process, giving an artistic sepia effect that makes the 1922 calendar especially attractive.

Attend House Warming

The Victor wholesale sales force of Lyon & Healy recently attended a housewarming, given in honor of Mr. and Mrs. L. C. Wiswell. Mr. Wiswell, who is manager of Lyon & Healy's Victor department, was recently married and the housewarming was a surprise by the sales staff.

New Brunswick Shop

The McKinley Park Music Shop is the name of the new exclusive Brunswick shop that was recently opened at 1956 West Thirty-fifth street, this city. A. O. Schaller, the proprietor, be-

Cherington Pressed Steel Turn-Table

No matter how excellent the sound reproduction of a phonograph may be, or how smoothly the motor may run, or how artistically the cabinet may be finished, the machine is not perfect *unless the turn-table runs true*. A wabby turn-table not only detracts from the appearance of a phonograph, but also appreciably affects the music and causes uneven wear of records.

Cherington Turn-Tables run absolutely true. They are made from cold rolled, dead soft steel, stamped out on a 200-ton double-acting press, which insures accurate shaping.

Manufacturers can add the final *perfection touch* to their machines by buying motors without turn-tables, and equipping them with Cherington Pressed Steel Turn-Tables. Furnished with any covering desired and finished either in gold or nickel plating. Quotations on request.

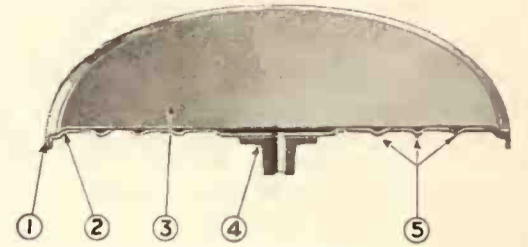
**Features of Cherington Turn-Table**

1. Separate ring to hold covering. Prevents frayed edges, keeps covering from loosening and makes replacing easy.
2. Extra beading of ring stiffens turn-table.
3. Covering held in place snugly. Cannot come loose, can be easily replaced with any covering desired.
4. Hub is welded to turn-table.
5. Liberal beading of face of turn-table—3 parallel circular corrugations and 6 cross beads—stiffens table and absorbs contraction or expansion due to varying temperatures.

**CHERINGTON MFG. COMPANY
WAUKEGAN, ILLINOIS***Manufacturers of famous Cherington Enclosed Phonograph Motors*

lieves in preparedness and when laying out his shop made provisions for future enlargements. The new shop has six demonstration booths, which are handsomely fitted and decorated.

Business and Pleasure

Manager John McKenna, together with his staff of Columbia territory representatives, held a monthly sales conference, in which business was combined with pleasure, on October 15, at Antioch, Ill. Regarding the business part of the conference we have no authentic information relating to its exact nature, other than it had to do with the disposing of more Grafonolas than records for the ensuing



month, but the pictures we represent herewith tell their own story. Disciples of Izaak Walton will note, with outbursts of guffaws, the manner in which Manager McKenna grasps that particular implement known as a fishing pole, and will deduct therefrom that this gentleman is better versed in the art of selling Grafonolas than in the role of a fisherman. But Mr. McKenna is not alone in being inexpert in the fishing art. We understand that Messrs. Blimke and Reilly also went fishing in the early morning hours, but returned in the

middle of the day with a tale that there were no fish in the lake, after they had ridden through

**Columbia Out-of-town Travelers**

Standing, Reading from Left to Right—Messrs. Merrin, from Michigan; Tucker, from Southern Illinois; Binger, from Indiana, and Walley, from Milwaukee. Seated, Reading from Left to Right—Messrs. Leon, from Middle Illinois; McKenna, Mueller, from Iowa, and Wichthorst, from Northern Wisconsin

three lakes and exhausted all the supplies they took with them.

Allow the Travelers to Become Members

Originating in the West—whence most good things come—is the move for enlarging the National Association of Piano Travelers to include everybody in the allied industries, including travelers for talking machine and record concerns,

*(Continued on page 120)***TRANSFER NAME-PLATES**

We make the Transfer Name-Plates and Trade-Marks for the largest talking machine manufacturers in this country and for dealers in every state.

YOUR NAME, Mr. Dealer, on every machine brings the owner back to you or records and his friends to you for a machine.

*Samples, Suggestions and Sketches Furnished Free***THE MEYERCORD COMPANY, CHICAGO**

Largest Manufacturers of **DECALCOMANIA** Transfer Name-Plates

Let's Go—

and get the business; we have waited long enough—that's a new slogan adopted by a few progressive manufacturers and dealers.

Cy Kology tells us—get a person interested and you have made a sale.

99% of the people who see a

REPEAT-O-STOP or REPEAT-O-GRAPH

are sold—There's large profit in it for you. Why not save your repair man's salary by selling one of these repeating devices? Put one in your window on a phonograph or in a conspicuous place on your show room floor and watch results.

AUTOMATICALLY REPEATS YOUR RECORD
WHILE YOU DANCE OR DINE.

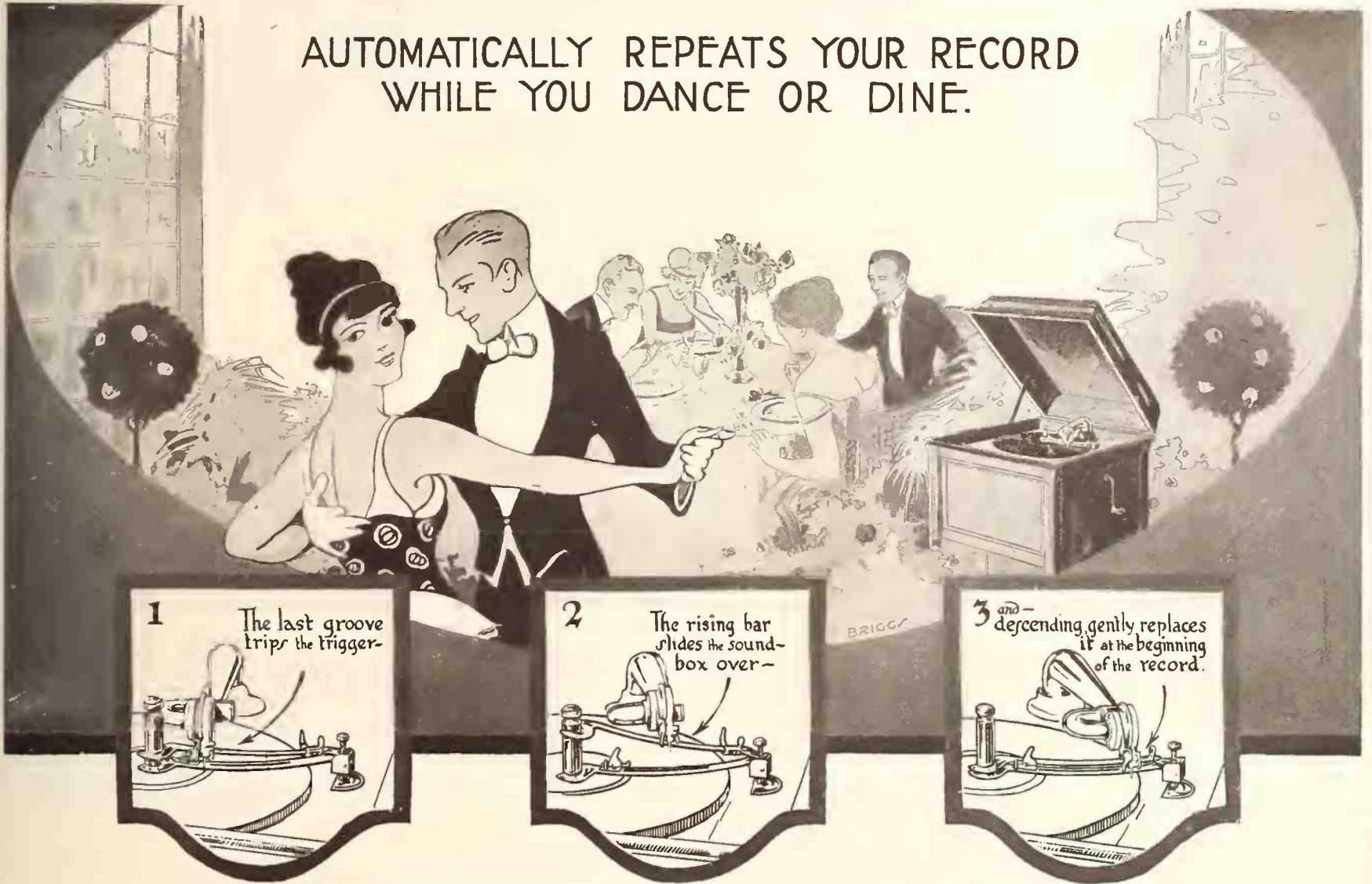

THE NEW PRICES OF THE INSTRUMENTS

Repeat-O-Stop, nickel \$6.00; gold \$8.50
Repeat-O-Graph, " 5.00; " 7.50

ALWAYS STATE NAME OF MACHINE YOU ARE USING.

We will furnish literature, advertising matter and guarantee to show you how these can be sold in a big way and make you some money between now and Christmas.

Do not delay—send your order today

REPEATING DEVICES CORPORATION

CHICAGO

408-10 Sullivan Street
Phone: 8010 Diversey

NEW YORK

Van Alst and 14th Sts., Long Island City, N. Y. C.
Phone: Hunters Pt. 6000

PHILADELPHIA, PA.

422 Lafayette Bldg.
Phones: Bell-Lombard 2553
Keystone-Main 3627

BOSTON, MASS.

200 Devonshire Street
Phone: Main 5122

PITTSBURGH, PA.

609 Chamber of Commerce Bldg.
Phone: Grant 8741

DETROIT, MICH., 1604 David Whitney Bldg.

Phone: Cadillac 6651



No. 16

Style—Adam.
Wood—Selected figured mahogany. All solid mahogany hand carvings.
Dimensions—Height, 36 inches. Width, 39½ inches. Depth, 23½ inches.
Finish—Red, brown and satin.
Trimmings and Equipment—Best quality gold plated.

Here is the big drop you have been looking for. Our special trade prices for all machines illustrated.

1 to 5 Machines, **\$80.00** each

5 to 10 Machines, **\$75.00** each

SHARP REDUCTIONS ON Federal Consoles



No. 18

Style—Sheraton inlaid on doors and legs.
Wood—Selected figured mahogany.
Dimensions—Height, 36 inches. Width 39½ inches. Depth, 23½ inches.
Finish—Red, brown and satin.
Trimmings and Equipment—Best quality gold plated.



No. 20

Style—Queen Anne.
Wood—Selected figured mahogany.
Dimensions—Height, 36 inches. Width, 39½ inches. Depth, 23½ inches.
Finish—Red, brown and satin.
Trimmings and Equipment—Best quality gold plated.

FEDERAL PHONOGRAPH CORPORATION

1458-1464 W. Kinzie Street

CHICAGO, ILL.

FROM OUR CHICAGO HEADQUARTERS—(Continued from page 118)

small goods people, supply goods men, etc. The men behind this move are Gordon Laughead, M. J. Kennedy and Kenneth Curtis, all of Chicago. If the idea goes through there might be 2,000 members in the N. A. P. T. instead of 300. In an organization of this kind a lot of things could be done. The move for a 5,000-mile, 2½-cents-per-mile mileage ticket could be pushed. The impertinent or exorbitant hotel proprietor could be shown exactly where he gets off. All sorts of things could be done for the interest of the trade, and a spirit of camaraderie and co-operation built up which would be potent in case of emergencies. There will unquestionably be a motion to amend the by-laws in this sense at the next meeting of the N. A. P. T. This could be done and new members accepted at their meeting. The annual convention will take place in New York in June of next year. Anyone interested in seeing this thing go through might write to M. J. Kennedy or Gordon Laughead, both of whom are at 532 Republic Building, Chicago, or Kenneth Curtis, whose address is 25 East Jackson boulevard.

The Uptown Exhibit

The business men of the North Side have come together for the purpose of boosting that part of Chicago. During the first week of November they held what they called the "Uptown Exhibit"

at the Broadway Armory, 5875 Broadway. This exhibit was composed of many interesting booths and practically every business on the North Side had a demonstration of some sort. The exhibit of Lyon & Healy attracted much attention at their booth, where they showed about everything known in the music line. Other Victor sections attracted many people by reason of the constant playing of popular Victor records, as well as several well-known artists who were on the bill. Small pocket mirrors were given away.

Change of Managers

A. T. Boland, of the Lyon & Healy wholesale Victor sales force, has been made manager of Lyon & Healy's Sheridan road branch. Mr. Boland succeeds Tom Chadwick, who looked after this branch for many months.

Congratulations!

The happiest kind of a smile now adorns the face of V. K. Tremblett, of the sales force of the Chicago Talking Machine Co., and he has every reason to smile. He was recently married to Miss Irene Esch, daughter of the Hon. J. J. Esch, a member of the Interstate Commerce Commission. The wedding took place at the Esch residence at LaCrosse, Wis.

Good Repeater Window

For the past week there has been a very clever little window display over at the Wade Talking

Machine Shop, which has been the means of attracting scores of people. The little exhibit is none other than a method of showing or demonstrating how the Geer record repeater works. This repeater is manufactured by the Walbert Mfg. Co., of this city. There is, in the foreground of the window, a large vase of transparent glass, and on it is an electric motor, on which rests a turntable and tone arm and sound box. The motor sits down in the vase and the turntable and tone arm support are of the regular Columbia graphophone type. There is a record on the turntable, which is kept going continuously, and the music of the record is picked up from the sound box by means of two very thin and cleverly concealed wires, which, in turn, lead to a Magnavox, situated under the window. The record is repeated continuously by the Geer repeater. The simplicity of the contrivance causes the people to wonder how they can hear the music through only the tone arm. They, of course, are not aware of the concealment of the Magnavox. The repeater works in the following manner: The adjusting arm is set for the size of the record and is held in place by the needle, which traverses the grooves in the record. When the needle travels out to the end of the adjusting arm of the repeater it slips from under the needle and the entire repeating device makes one-half revolution, scoops up the needle and, by means of a trough-like arrangement in the repeater, causes the sound box holding the needle to travel back to the starting point. The simplicity of the whole arrangement has proved exceptionally attractive to the passers-by, and this little stunt has been the means of bringing about a great number of sales of the Geer repeater in the Wade establishment.

Death of Joseph J. Walsh

The sales force of the Chicago Talking Machine Co. was recently stunned by the sad death of one of their members, Joseph J. Walsh. Mr. Walsh for eight months had been in charge of the city desk at the headquarters of the Chicago

THE \$1.00 CUTTER—HERE IT IS

Retail Price

\$1.00

A better Fibre
Needle Cutter
for less money

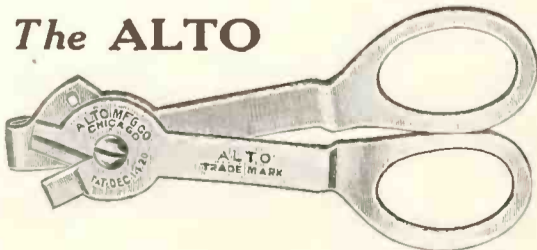

Made Entirely
of High-Grade
Steel

ALTO MFG. CO. - 1801-1803 Cornelia Avenue, Chicago, Illinois

FROM OUR CHICAGO HEADQUARTERS—(Continued from page 120)

Talking Machine Co. He had stayed downtown one evening with a friend and on his return home was waylaid and slugged by some unknown thugs. He was picked up unconscious in a section of the city far removed from his home and was removed to the Cook County Hospital, where he died without regaining consciousness. Mr. Walsh is survived by a widow and boy four years old, who, with many friends, mourn his passing.

Piano Club Entertains Geo. P. Bent

On the evening of November 7, at the Drake Hotel, the Piano Club of Chicago put on an exceedingly elaborate testimonial in honor of George P. Bent, father of Chas. Bent, of the Bent Music Shop. Mr. Bent has just returned from a trip around the world, which lasted many months. It proved to be one of the biggest turnouts in the history of the local trade.

Western Condition

C. C. Slack, of the Melody National Sales Co., has just returned from a trip throughout the Central West and reports that the dealers in that section are very optimistic and encouraged by the present trend of the trade. "One of the things that is noticeable is that many of these dealers are now getting closer to their trade by means of daily conferences which they are holding with their salespeople," he remarked. "The owners and managers of these places are paying more attention to trade conditions than ever before. They are making a keener study of conditions and at these conferences they tell their salespeople exactly what they have found out pertaining to business in general. For the past few years it was necessary to do much salesmanship. A clever salesperson was not appreciated. All that was necessary was an order taker, but order takers are now fast disappearing and the real salesman is again being appreciated."

Wins Vocalion Prize

Manager H. B. Levy, of the Chicago division of the Aeolian Co., has just made the announcement that Carl Staufenbeil, an Aeolian dealer at



The Artistic Vocalion Window

Dubuque, Ia., has won first prize in the tri-State contest recently put on by the Aeolian Co. in Iowa, Illinois and Wisconsin for the best-dressed show window in which the Aeolian-Vocalion was featured. The prize was \$50. The idea for the window was originated by two Staufenbeil employes, the Misses Aurelia Scott and Martha Wagner, who themselves superintended the work of carrying out the window display.

New Fullerton Avenue Columbia Store

A new and exclusive Columbia shop has just been opened at 3732 Fullerton avenue, and is being conducted by H. M. Hendricksen, who for several years has had a drug store in the same

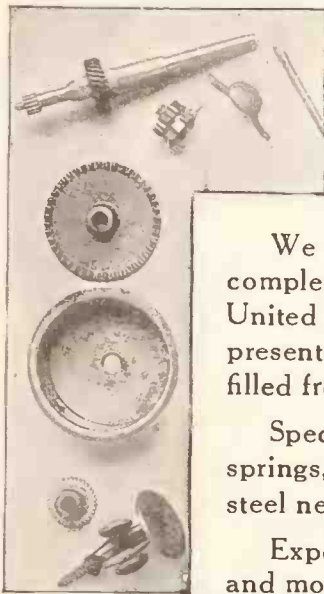

Repair Parts

For All and Every Motor That Was Ever Manufactured

We can supply any part. The largest and most complete assortment of repair parts—in the United States—on hand, for old, obsolete and present-day motors. If your order cannot be filled from stock, we will make it up special.

Special prices on main springs, governor springs, micras, repair parts, motors, tone arms, steel needles, etc., in quantity lots.

Expert repairing on all makes of phonographs and motors.

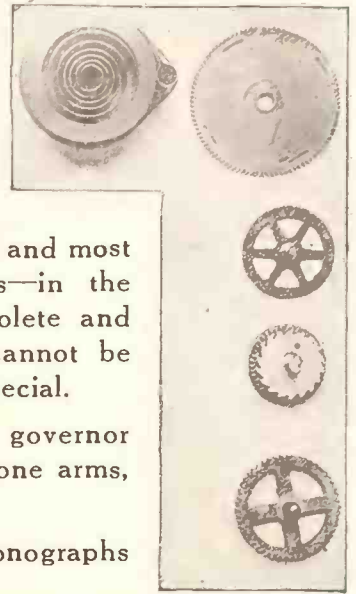

INCORPORATED UNDER THE LAWS OF ILLINOIS

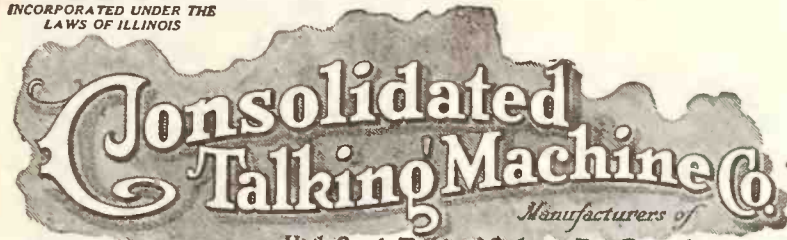

SUCCESSORS TO Standard Talking Machine Co. United Talking Machine Co. Harmony Talking Machine Co. O'Neill-James Co. Arstino Co.

High Grade Talking Machines, Disc Records, Talking Machine Supplies, Etc

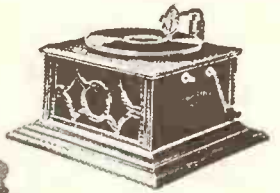

TRADE MARK "CONSOLA"

CABLE ADDRESS "CONSOLA"

227-229 W. WASHINGTON ST., CHICAGO, ILL. Branch: 2957 Gratiot Ave., Detroit, Mich.

building. Although a newcomer in the talking machine business, Mr. Hendricksen gives every evidence of becoming a live wire. His new shop has only been open for a little more than a week, but he has already organized a canvassing force, which is out after all the business in that section. Mr. Hendricksen himself devotes his time in the morning towards the personal supervision of his canvassers, who have already succeeded in closing quite a number of new accounts.

Prepare for Concert

The Chicago retail Victor dealers met at a luncheon October 19 at the Illinois Athletic Club, and formulated plans for the coming concert of the Eight Famous Victor Artists. This concert will be given at Orchestra Hall, on November 28 and 29.

Welcome Back, Old Top

G. P. Ellis, secretary of the Chicago Talking

Machine Co., has again returned from a visit to the University Hospital at Philadelphia, Pa., where he has been receiving treatment for a frontal nerve affection. Mr. Ellis is looking in the prime of health and it is understood that the skill of the doctors who are treating him is fast clearing up his trouble.

Bristol Tells of Rockford's Pageant

One of the recent visitors to the Chicago trade was E. S. Bristol, proprietor of Bristol's Brunswick Shop at Rockford, Ill. He said that during October the tradesmen of Rockford got together and had a Pageant of Progress which lasted for several days. The whole town was rigged up in gala attire and the event brought more visitors to Rockford during the three days than anything that ever happened there before.

"Chicago gave the idea of a Pageant of Progress to the world," said Mr. Bristol, "and I hear

(Continued on page 122)

Price Reductions on Enclosed Motors

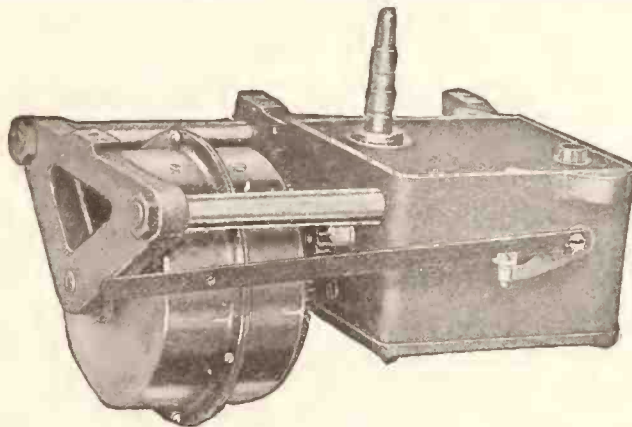

We have recently made sharp reductions in the prices of enclosed, self-lubricated motors—due to decreased costs in labor and material and a larger output.

This will put the Enclosed Motor within the reach of those manufacturers whose desire has been to use this motor, but whose lines have not been high enough in price to do so.

The same quality and high degree of inspection will be maintained.

REMEMBER

You don't have to tune this motor. It comes to you silent and smooth running. It reaches your customers in the same condition.

Ask about various models and prices.

United Manufacturing and Distributing Company
536 Lake Shore Drive CHICAGO



Edison Diamond Amberolas--Plus Service

You know the quality of Edison instruments. Until you have placed a trial order with us, you are unfamiliar with SERVICE.

A TRIAL CONVINCES

Our Service Covers the Country

William H. Lyons

Formerly Jas. I. Lyons
17 W. Lake St. Chicago

FROM OUR CHICAGO HEADQUARTERS—(Continued from page 121)

from trade friends of mine throughout the country that towns and cities everywhere now have the idea and have either pulled off a pageant or are contemplating one. I know that in our town the merchants profited greatly. In my own particular case the business the pageant brought me was phenomenal and the publicity I derived through it has brought me hosts of new customers. Every merchant had his stunt to attract the people.

"My attraction was Bert Ibberson, who is known throughout the country as 'the man who never smiles.' He proved himself a good drawing card and I made the announcement that he would be at my store at 8 o'clock every evening and that I would give a record to any one who made him smile. The crowd in and about my store at the specified time was tremendous and when one young lady finally made him smile by pulling his face down and kissing him I immediately gave her the prize—one Brunswick 'Ma' record. The young lady on receiving her prize gave the audience the benefit by playing it on a talking machine. After the record had been played I made the announcement that it was now on sale and my clerks were then in for a busy time until three hundred Brunswick records were disposed of." Mr. Bristol was formerly Illinois wholesale traveler for the Brunswick-Balke-Collender Co.

Dr. Lund's Tribute to the Steger Phonograph

Dr. Anthony C. Lund, conductor of the great Tabernacle Choir in Salt Lake City, is a great admirer of the Steger phonograph, made by the Steger & Sons Piano Mfg. Co., of this city. In a recent statement regarding this phonograph he says, among other things:

"Careful study and investigation have convinced me that the Steger is unquestionably the finest reproducing phonograph. In selecting it for my home I have been guided by the highest artistic and musical ideals. There are many reasons why the Steger ranks supreme, but I consider the following of greatest importance:

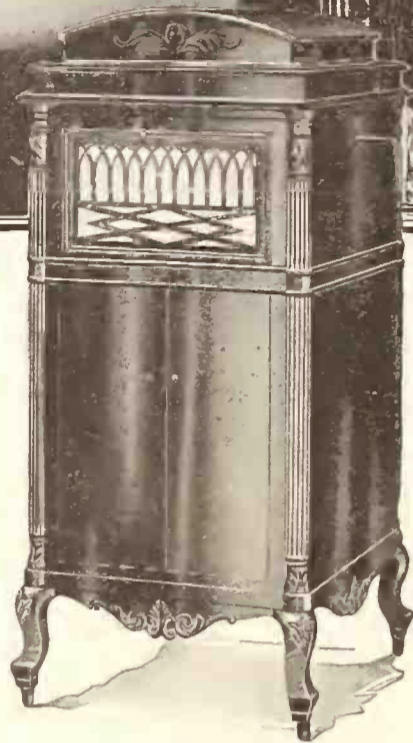
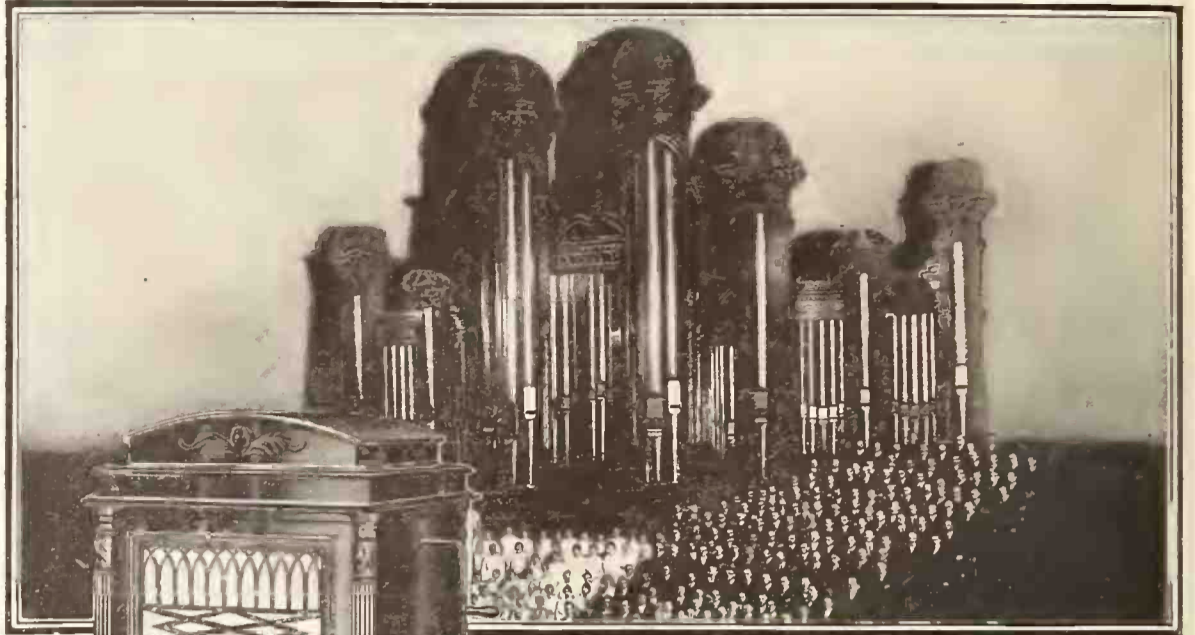

Steger Phonograph and Tabernacle at Salt Lake
ence of the phonograph and imagine that the artist is present in person. This distinctive fidelity of reproduction gives you the music in all its purity and beauty.

"2. All artists, all music, like the magic carpet of the Arabian nights, the Steger phonograph unfolds a world of beauty by bringing to the home all the best music as played and sung by the world's foremost artists. The Steger phonograph plays all makes of records correctly.

"3. The balanced tone arm. Every make of record requires a different pressure of the tone arm to insure perfect tone reproduction. The Steger plays all records correctly, because it is equipped with an adjustable tone arm, a feature I have seen on no other phonograph.

"4. The all-wood sound chamber produces a great volume of music without metallic sounds. 5. Beauty of design. 6. Excellence of construction. 7. Convenience of operation. 8.

"1. Perfect reproduction. When you hear the voice of a singer or the music of an instrument reproduced by the Steger it is so natural and lifelike that you actually forget the pres-



MODEL No. 500



Two New Models
Available for the
CHRISTMAS TRADE



MODEL No. 52

Here are two live, snappy, new models in our line made of the finest materials and moderately priced.

You can't go wrong on these!

Wire or write for samples and prices.

The Wolf Manufacturing Industries

Manufacturers of High Grade Phonographs

QUINCY

ILLINOIS

FROM OUR CHICAGO HEADQUARTERS—(Continued from page 122)

The name 'Steger' is the strongest guarantee of this superb phonograph's excellence. It is a name known to thousands and thousands of musicians and music lovers the world over as the symbol of musical worth.

"In appreciation of the many pleasant hours when I have enjoyed my Steger phonograph



Dr. Anthony C. Lund

and in recognition of its superb qualities, I am delighted to add my endorsement to the long list of those who have acclaimed the Steger's musical excellence."

Hinged Cover Support & Balance Co. Meeting

In connection with the affairs of the Chicago Hinged Cover Support & Balance Co., adjudged bankrupt by the United States District Court, Sydney C. Eastman, referee in bankruptcy, has scheduled a meeting of the creditors on the 15th of this month, for the purpose of appointing a trustee and hearing the claims presented.

Fire at Baird & Roberts

Damage estimated at \$20,000 was suffered by the Baird & Roberts Phonograph Mfg. Co., of 21 South Hoyne avenue, by a fire which started on the top floor of the four-story structure occupied by the company. Firemen had a difficult time in checking the flames from spreading to surrounding buildings and additional fire apparatus had to be called before the flames were finally extinguished.

Fibre Needles and Bamboo

The story of bamboo as it enters into the making of fibre needles is decidedly interesting. In Science and Invention of some months back there appears on the front cover a colored reproduction of a fibre needle in the groove of a talking machine record, magnified many times. The picture strikingly illustrates the action of the forces which work ultimately to destroy any needle, whether of steel or fibre. It explains graphically why it is so necessary to use great care in the selection of proper bamboo for the fibre needle.

In an interview with F. D. Hall, president of the Hall Mfg. Co., some interesting side lights on this matter were brought out. In this gentleman's office is a gigantic piece of bamboo, part of the trunk of a perfect specimen, which



Quality vs. Business

Jobbers realize more than ever the value of a Quality Phonograph.

Hiawatha business in the past year has demonstrated that Quality will prevail.

Cabinet Construction guaranteed.

Piano Finish.

Equipment the very best Quality.

Hiawatha Tone a perfect reproduction.

Jobbers and Dealers can verify Hiawatha Quality.

Seven Models to select from.

HIAWATHA PHONOGRAPH CO.
 209 South State Street Chicago, Ill.

Mr. Hall brought back with him from Japan solely for exhibition purposes. Says Mr. Hall: "The ideal bamboo for making fibre needles is called ivory bamboo. Its surface resembles ivory in its smoothness. There are no ridges or imperfect streaks running through the wood which might make a soft point if the needle were cut along them. This particular kind of bamboo is very difficult to obtain." Mr. Hall went on to explain that the purpose of his recent trip to Japan was to make arrangements whereby the Chicago factory should be assured of steady shipments of the best bamboo obtainable. He brought back with him one of the finest works of Japanese art that it has ever been the privilege of the writer to view. It is a picture embrodered in silk showing a bamboo forest which Mr. Hall himself has seen in real life. It portrays some of the perfect bamboo of which we have spoken. Never did a painting in oil show more faithfully or vividly the lighting effects of an Oriental scene.

Rodeheaver Record Co. Activities

The Rodeheaver Record Co. has moved its Chicago headquarters from 440 South Dearborn street to the sixth floor of the McClurg Building at 218 South Wabash avenue. The new location gives the company practically the entire sixth floor of this well-known building, which has been fitted with new offices, stock rooms and one large reciting and recording room, which

measures about fifty by seventy-five feet. The manager of this branch is E. H. Forkel.

This concern was the scene of much activity for the past two weeks, during which time Thos. P. Ratcliff, general manager of the company, was here supervising the recording of several numbers by Homer Rodeheaver. Mr. Ratcliff, as is well known, is a song leader for Billy Sunday, the famous baseball evangelist, who is now touring the Central West. Mr. Rodeheaver recorded fifty new numbers, which will be placed on the market by the first of the year, besides the recording that was done for Mr. Rodeheaver. Mr. Ratcliff supervised the recording of fifty-six numbers for private individuals who wanted these records for Christmas gift purposes. Many of the friends of the Rodeheaver Co. were given a recital managed by Mr. Ratcliff. The recital consisted of some vocal numbers by Mr. Rodeheaver and a lecture by Mr. Ratcliff on the making of records. He showed the audience how a number was recorded and then let them hear the reproduction from the original wax record. He also illustrated the various processes of record making from start to finish.

One recording of vast importance which was supervised by Mr. Ratcliffe while he was here was a number of marches played by the Chicago Daily Newsboy's Band. This band is perhaps the oldest of Chicago's industrial bands. It was

(Continued on page 124)

48 HOUR SERVICE

Write for our big new Christmas bulletin. Just off the press. No matter what your needs are—either in the phonograph line or the small goods line—we can furnish your needs on any quantity and guarantee immediate delivery at lowest market prices.

COLE & DUNAS MUSIC COMPANY
 560-5 WEST LAKE STREET CHICAGO, ILL.

FROM OUR CHICAGO HEADQUARTERS—(Continued from page 123)

originally started in this city many years ago and is composed of newsboys only. The band to date is made up of sixty pieces. In the old days the Chicago Daily News organized this band for the purpose of encouraging music. Its organization stimulated music throughout the industrial field here and many of the old-timers in Chicago concede that this band was really the nucleus of industrial music here.

In commenting upon the music and its possibilities in Chicago Mr. Ratcliff stated that the musicians as a whole that he ran across during his short stay in Chicago showed a spirit of co-operation greater than he had ever seen in any other city. For example, he pointed out that in other cities there were some mighty clever musicians, but he had never found, in getting up a temporary orchestra for accompaniment purposes, any group of musicians, strangers to each other, that could co-operate in such short order.

A Live Secretary

It looks as if the new secretary of the Chicago

Piano Club were a highly charged live wire. We suspected this when we elected John McKenna to the position. Now that we have received two or three weekly notices from his pen we are convinced of the fact. Let it be understood by those who do not know that talking machine men in the Chicago Piano Club make up one of its liveliest elements, and John McKenna is their leader.

NEW "JEWEL" EXECUTIVES ELECTED

T. E. Davidson Elected President and A. B. Cornell Treasurer of Jewel Phono Parts Co.—Well Known in Trade and Familiar With Industry—Business Is Increasing Rapidly

CHICAGO, ILL., November 7.—The Jewel Phono Parts Co., of this city, manufacturer of Jewel tone-arms and Jewel attachments, has made important promotions in its executive personnel which reflect the signal success of this company and emphasize its progressiveness. At a

New North Side Manager
A. T. Boland has been appointed to succeed H. Chadwick as manager of the North Side branch store of Lyon & Healy. Mr. Boland brings to his new position a wide experience in musical instrument selling and plans to develop thoroughly the North Side territory. He expects to build up an even more profitable business than this store has yet enjoyed.

recent meeting of the stockholders and directorate, T. E. Davidson was elected president and production manager, Fred Schroeder was re-elected vice-president and A. B. Cornell was elected treasurer and sales director. Judge A. A. Rolf, who is the company's counsel, was elected secretary of the company. Practically all of the holdings controlled by the smaller stockholders were bought out, and the stock is now controlled by Messrs. Davidson, Schroeder and Cornell, who, with Judge Rolf, constitute the directorate of the company.

This important move was made so that the executive personnel of the Jewel Phono Parts Co., which has been instrumental and responsible for this company's success, will be in direct charge of the business in the future. On January 1 of this year Messrs. Davidson and Cornell took active hold of the Jewel business, and during this year they spent considerable time in developing new merchandise and perfecting the various products that comprise the Jewel line. The results of their efforts have been recognized by their recent election as officers of the company. Mr. Schroeder is a retired capitalist who gives the greater part of his time to various business interests, leaving the Jewel activities to his associate executives.

Mr. Davidson is a practical mechanical engineer who has held important executive posts in some of the country's greatest industrial concerns, and who has been identified with the talking machine industry for many years in executive and advisory capacities. During the war Mr. Davidson was the inventor and general engineer in charge of an altitude and speed machine of the most complex construction that is now used as a standard in the United States Government airplane service.

Mr. Cornell has been connected with the talking machine industry for a great many years in various capacities. He is thoroughly familiar

(Continued on page 126)

Here Is the Difference

Only the **Trained Expert** Can Identify a Criminal by His **Finger Print**

ANYBODY Can Identify

THE AMBASSADOR PHONOGRAPH

By Its Superior Tone Quality

Not Just a Machine—a Musical Instrument
THAT'S THE AMBASSADOR

Mr. Dealer

Order one machine. Prove our claim. You'll end by handling our line. So why delay?



Mr. Jobber

Maybe your territory is still open—find out—you can't afford to pass this up.

Where Discriminating Purchasers Appreciate Value, Quality and Tone Perfection, You **ALWAYS** Find **THE AMBASSADOR**

AMBASSADOR PHONOGRAPH CO.

EXECUTIVE OFFICES:
Suite 201
312 SO. CLARK STREET
PHONE WABASH 6827

CHICAGO
ILL.

SALES OFFICE:
Suite 300
19 W. JACKSON BLVD.
PHONE HARRISON 9530

A High-Class Cutter

Sharpens the Fibre Needle without removing it from the Tonearm.

THE **LIDSEEN Fibre Needle Cutter**

CONVENIENT

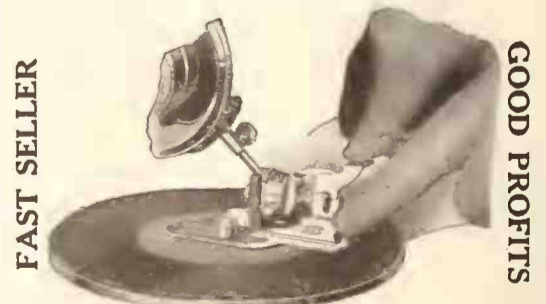

FAST SELLER

GOOD PROFITS

MECHANICALLY RIGHT

Jobbers—Line up on this live one and get ready for the season.

LIDSEEN

832-840 So. Central Ave., CHICAGO

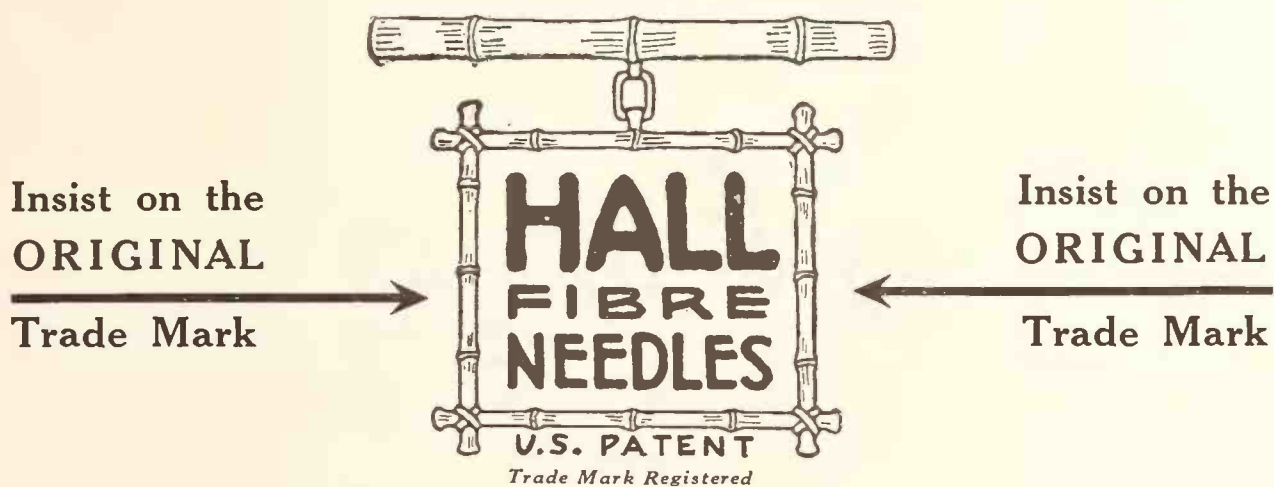

Prestige

Just as the far-sighted talking machine merchant selects his lines of phonographs and records with an eye to the sort of quality and reputation best calculated to maintain prestige in his locality—

So does the fore-sighted talking machine merchant select the **HALL FIBRE NEEDLE** as the one best calculated to attract a quality trade to his store.

HALL MANUFACTURING CO.

Successor to the B & H Fibre Needle Co.

33-35 W. Kinzie St., Chicago, Ill.

FROM OUR CHICAGO HEADQUARTERS—(Continued from page 124)

with every phase of the trade, and as sales director of the Jewel Phono Parts Co. has won the esteem and friendship of the jobbers and dealers throughout the country. In addition to his sales experience, Mr. Cornell has devoted considerable time to the technical and experimental phases of the industry, and his knowledge has proven invaluable in the development of Jewel products.

It is interesting to note that in spite of the general business depression during the past year, the Jewel Phono Parts Co. has shown a profit month after month. For the past two months its sales have been at high-water mark, with every indication that its activities will increase steadily during 1922.

Three New Windsor Models

The Windsor Furniture Co., through its president, J. W. Lyons, makes the announcement to



No. 31, Windsor Phonograph

the trade this month that it has placed on the market three new models of the artistic console type, which are known as the No. 28, Queen Anne, No. 31, Italian Renaissance, and No. 32



No. 32, Windsor Phonograph

Chippendale. These instruments are furnished in solid mahogany with finishes ranging from old ivory to ebony, as well as a variety of polychrome enamels. The solid oak machines put



No. 28, Windsor Phonograph

LAKESIDE PHONOGRAPH PRODUCTS

Number your records and you have a non-set stop.

The best automatic stop on the market.
Sample \$1.40

Send for a sample electric motor
Complete \$19.50

The best electric phonograph motor on the market. Made for use on voltages from 32 to 250.

Send for our parts catalogue

LAKESIDE SUPPLY CO.
416 S. Dearborn St.
CHICAGO, ILL.
Telephone Harrison 3840

out by this company range from silver gray to fumed and cathedral. The figure work and festooning on Nos. 31 and 32 are in solid mahogany and hand-carved, and there is absolutely no compo on any part of these machines. The sizes of these instruments are as follows: The No. 28 is thirty-four inches wide, thirty-six inches high and 21 inches in depth. The Nos. 31 and 32 approximate forty inches high, thirty-two inches wide and twenty-one inches deep.

The Windsor Furniture Co. is now showing these new models in both its new downtown salesroom, at 1411 South Michigan avenue, Chicago, and in the warerooms of its Eastern distributors, Hyman Bros. & Co., 47 West Thirty-fourth street, New York City. These new instruments, together with the balance of its new line, will be on exhibit during the January and July furniture expositions in the Blodgett Building, Grand Rapids, Mich.

A Splendid Record

The Hiawatha Phonograph Co., with factory at Geneva, Ill., and offices in the Republic Building, this city, has run continuously since 1916, closing down its plant only a week to ten days each year for the purpose of taking inventory. During the most trying period of this year the Hiawatha business proceeded along its usual way, and General Manager Moynihan says that it has been clearly demonstrated that a quality article will overcome the most adverse

conditions. Right now Hiawatha business is increasing and Mr. Moynihan and his associates feel that at the close of the present year they will be able to point to a great record of achievement.

Productive Mailing Lists
Compiled by the Man Who Knows How

You want your trade mailing list to be the best it can be—of course. A poor list—incomplete, inaccurate and badly arranged—means constant trouble, loss of business and heavy expense.

It has been my observation, after years of experience and exhaustive study, that a large majority of mailing lists in use are less than 60 per cent efficient—which means enormous waste.

I HAVE NOTHING "CANNED" OR "READY MADE" TO SELL, BUT I SPECIALIZE IN COMPILING AND ARRANGING TRADE MAILING LISTS AS NEARLY 100 PER CENT EFFICIENT AS SUCH LISTS CAN BE MADE.

Let me know what territory you wish to cover and I will build you a real business-getting, time-saving, waste-preventing list adapted to your particular business that will add an invaluable asset to your selling equipment.

Get my proposition before making another mailing—it will surprise you.

DORCHESTER MAPES

10314 So. Hamilton Avenue, Chicago

Melody Portable Phonograph

Equipped With

Double Spring Motor

Blood Tone Arm and Reproducer

Removable Tone Arm and Winding Key

Durably Constructed. Mahogany Water-proof Finish. Brass Trimmings. Carries 10 Records. Wonderful Tone—equal to that of a \$200 machine. Plays all records—soft, medium or loud as desired. Portable—Weighs only 18 pounds.

PROMPT DELIVERY

Here's a Winner for You!

Write for Sample and Terms Today.



Size 8x13x15



Portable

Weights 18 Pounds

Take It With You Anywhere!
Have Music Where You Want It!
In Your Home—In the Nursery
—At the House Party—Camping
Out—At the Summer Home—
Boating or Canoeing—

MELODY NATIONAL SALES CO. 190 N. State Street, Chicago, Ill.

FROM OUR CHICAGO HEADQUARTERS—(Continued from page 126)

BENSON ORCHESTRA PLAYING AT MARIGOLD GARDENS

Famous Chicago Organization Winning Success at Popular Resort—What Edgar A. Benson Has Accomplished in Orchestra Work During a Quarter of a Century

CHICAGO, ILL., November 9.—The Benson Orchestra, which is recording exclusively for the Victor record library, has been achieving phenomenal success at Chicago's popular amusement place, "Marigold Gardens." This orchestra is recognized as one of the foremost musical organizations of its kind in the country, and Victor deal-

mand, it is not difficult to understand why the Benson Orchestra of Chicago, which is selected from the many Benson dance orchestras, is pleasing not only the people of Chicago but the music and dance lovers of the whole country through the medium of Victor records.

The recording orchestra was formed some time



The Famous Benson Orchestra of Chicago

ers everywhere, particularly in the Middle West, are featuring to excellent advantage the fact that Benson's Orchestra records for the Victor library exclusively.

Twenty-five years ago Edgar A. Benson began organizing orchestras and other musical combinations for the entertainment of Chicagoans. Now, with hundreds of musicians at his com-

ago from members of various Benson musical organizations, among them being nine organized brass bands, five symphony orchestras, thirty organized dance orchestras, six jazz bands and ten novelty orchestras. Each man is the best Mr. Benson could procure—a man of originality, individuality and exceptional ability.

In selecting Roy Bargey, pianist, as director,

Mr. Benson has injected the touch of real talent which makes the orchestra perfectly balanced.

Among the members of this orchestra are found such experienced musicians as Arthur Layfield, drums, who has been with the Symphony Orchestra of the Chicago Grand Opera Co. for the past four seasons; Rick Adkins, cornet, and Guy Cary, trombone, for many years in the highest class vaudeville; Albert Walthall, violin, who wrote the music of the "Sultan of Sulu," to which George Ade wrote the lyrics; Mathew Amaturo, saxophone, for many years one of Chicago's most brilliant saxophone players and for two years with the Six Brown Brothers; and Joseph Baun, violin, Marvin Thatther, saxophone, Joe Mueller, banjo, and William Foeste, bass and bass saxophone, who have been with various Benson entertainers for from five to fifteen years.

Benson dance orchestras are playing regularly at the following Chicago hotels: Drake, Sherman, Sisson, Chicago Beach, Edgewater Beach, Blackstone, Morrison, Del Prado, Sheridan Plaza, Sovereign, La Salle, Auditorium, Cooper Carlton, Randolph, Great Northern, Congress, Am-lassador, Stratford, Hyde Park and Virginia.

Clubs: Chicago Athletic Club, South Shore Country Club, Evanston Golf Club, Lake Shore Club, Illinois Athletic Club, Standard Club, Midlothian Country Club, Chicago Club, Union League Club, Saddle & Cycle Club, Ravisloe Country Club, University Club, Casino Club, Ontwensia Country Club, Glenview Country Club and Chicago Lincoln Club.

Miscellaneous: Senate Theatre, Rainbo Gardens, Marigold Gardens, Stevens Restaurant, LaSalle Hotel Roof Garden, boats of the Goodrich Steamship Co., Detroit Athletic Club, Detroit, Mich.; Cleveland Yacht Club and Carlton Terrace, Cleveland, O., and Brandeis Café, Omaha, Neb.

The Melodia Phonograph Co., of Chicago, has increased its capital stock from \$20,000 to \$40,000.



STERLING

Reproducer with Edison Attachment

PLAYS ALL RECORDS



Write for New Prices on Sterling Tone Arms and Reproducers.

Sterling Devices Co.

Manufacturers of the No. 11 Sterling Non-Infringing Tone Arm, the Sterling No. 31 Tone Arm with Non-Set Automatic Stop, the Sterling No. 41 Ball-bearing Tone Arm, and the Sterling Reproducer fitted with Edison, Victor, or Columbia attachments.

534 Lake Shore Drive

Chicago, Illinois.

Just as the Proof of the Pudding Is in the Eating so the Proof of the Sterling Is in the Playing

The Sterling plays all records.

It is operated and entirely controlled by the lever same as the Edison.

The Sterling looks as though it were a part of the machine and not an attachment.

The Sterling Reproducer never needs be touched except to change the needle or to adjust from lateral to hill and dale and vice versa.

The Edison machine automatically moves the reproducer 150 threads to the inch and sufficient free motion is allowed by the Sterling for the difference between 150 and 80 threads. Upon the completion of the record, when the lever is operated to release the reproducer from the record, the reproducer automatically returns to its original or starting position.

The Sterling is the only reproducer that absolutely synchronizes when playing both hill and dale and lateral records.

BUSINESS IN MILWAUKEE SHOWS INCREASING ACTIVITY

Demand for Machines and Records Steadily Expanding—Dealers Placing Larger Orders and Tendency Now Is for a Shortage of Machines Around the Holidays—The Situation Reviewed

MILWAUKEE, Wis., November 5.—Business in musical instruments generally, and talking machines particularly, has made such good progress since the middle of October that earlier hopes for an active and profitable holiday season are now more substantially grounded than a month ago. In November, so far, the call for instruments has been especially good, compared with the last six or eight months, while the demand for records is exceeding expectations. Record trade has been good right along so its present active state is no surprise, but the manner in which machines have been selling in the last few weeks is notable. Ordinarily this is not the most active season for instrument merchandising, so the surprise is even greater.

The wholesale and manufacturing trade here finds a good deal of satisfaction in the attitude of the retail trade throughout Wisconsin and

upper Michigan, which usually is the territorial unit under their jurisdiction. Merchants have begun to anticipate their holiday needs in a broader way than a year ago and a fair movement of stocks from jobbers' floors is already under way. Dealers apparently have been waiting for signs of holiday activity before committing themselves and, now that it seems pretty well established that November and December trade is going to be active, they are coming into the market.

Dealers Stopping Hand-to-mouth Policy

Harry A. Goldsmith, secretary of the Badger Talking Machine Co., Victor jobber, said that, while Victor dealers in the State and upper peninsular territory have been placing some good orders for the last three or four months, it is only in recent weeks that the real demand for the holiday trade has opened up actively. The de-

mand is much better than a year ago and promises to be well sustained until early January. Stocks in the hands of retailers are unusually light, but the trade is rapidly getting away from the hand-to-mouth buying policy of the past and is more inclined to order ahead because dealers see good business ahead and do not want to get caught short when the holiday call becomes lively.

"Business in Brunswick records has kept up so well and is increasing so rapidly that we no longer regard this as a feature," said Thomas I. Kidd, manager of the Milwaukee branch of the Brunswick-Balke-Collender Co. "It is the way Brunswick phonographs are selling that makes us feel better every day. The console, as well as cabinet, styles are moving well and we are accumulating holiday orders faster than we can make deliveries. I am inclined to believe that we are going to have the best holiday season since the Brunswick line first was placed on the market in this territory."

Reports Excellent Edison Business

The Phonograph Co., Edison distributor, re-

Two New Period Models Added to Player-Tone Line



QUEEN ANNE MODEL
No. 300

Retail Price, \$150.00

Genuine Mahogany, hand-rubbed, piano finish. All metal parts gold plated.

HEIGHT 36" WIDTH 38"
DEPTH 22"



SHERATON MODEL
No. 250

Retail Price, \$135.00

Genuine Mahogany, hand-rubbed, piano finish. All metal parts gold plated.

HEIGHT 36" WIDTH 38"
DEPTH 22"

Insert showing round, white ivory horn and 5 record filing boxes



HEIGHT, 51½"
WIDTH, 24"
DEPTH, 25"

Five Wonders of the Age

- 1st. Unusually low retail selling price!
- 2nd. Big profits to the dealer!
- 3rd. Perfect cabinet work and finish!
- 4th. Exclusive design of latest type!
- 5th. Perfect tone and volume unsurpassed!

SEVEN UPRIGHT MODELS IN ALL FINISHES
BACK TO PRICES BEFORE THE WAR.

We also sell *cabinets only*. Write us for price on large and small quantity.

Write us today for Booklet and Discount to Dealers. We have got something good for you.

PLAYER-TONE TALKING MACHINE CO.
967 LIBERTY AVENUE, PITTSBURGH, PA.

ports an excellent business on an early holiday season basis and looks for one of the best December sales months in its history.

Increase Dalion Production

The Milwaukee Talking Machine Mfg. Co., manufacturing the Dalion, has made further enlargement of its production program for the last quarter in order to meet the demands from its trade in all sections of the country. The Auto-File, a distinct feature of the Dalion, has come to be appreciated to such an extent by owners that a great many sales are attributable to word-of-mouth commendation, due to the unusual convenience of this method of keeping records in good shape and at hand.

Displays at Local Exposition

The Yahr & Lange Drug Co., exclusive distributor of the Sonora, earned much favorable comment in the dealer trade, as well as among the people, for its vigorous promotion work at the third annual Food, Household and Electrical Exposition at the Milwaukee Auditorium, October 25 to 31. Co-operating with local dealers, the Yahr Co. staged numerous exhibits of great beauty and charm. It also co-operated with the General Phonograph Corp., of New York, in pushing the Okeh record, for which the Yahr-Lange musical merchandise division is the territorial distributor.

Larger Bradford Business

The J. B. Bradford Piano Co. is meeting with excellent success in merchandising the Aeolian-Vocalion instruments and Vocalion records. It also handles the Sonora and Victor lines and both stores have exceeded all past records for volume in the talking machine departments in recent months.

Pushing the Kimball and Okeh Lines

The Lyric Music Co., 88 Wisconsin street, is pushing the Kimball phonograph and the Okeh record and its unusual window displays, featuring the two lines, continue to arouse a great deal of interest and are building up a sales volume of surprising proportions.

Install New Demonstrating Booths

Charles J. Orth, Inc., 504 Grand avenue, has recently installed several new demonstrating booths, in order to take care of its growing patronage. The Orth house is now featuring the Brunswick in a retail way locally. In selling Brunswick records Orth's has gained an enviable reputation. Every record comes to the customer in a sealed package with the legend that this insures its never having been played, and this feature is making a distinct "hit" in the consumer trade. An unusually artistic showing of Brunswick console styles was made recently at the Hotel Astor during the annual Fall Fashion Show.

Handling the Pathé in Green Bay

The Green Bay Hardware Co., Green Bay, Wis., has recently been appointed district representative of the Pathé line and announced the new connection in large advertisements which featured its well-known slogan, "We can't sell all lines, so we handle only the best." The Actuelle feature of the Pathé is being stressed in all literature.

Wind Up Affairs of J. H. Ellis

The affairs of J. H. Ellis, formerly manufacturing the Ellis reproducer in this city, were wound up recently. Mr. Ellis filed a voluntary petition in July, scheduling liabilities at \$19,936.63 and claiming assets of \$231.85, with exemptions of \$110. Most of the creditors are noteholders. Oscar Schwemer, trustee, in his final report,

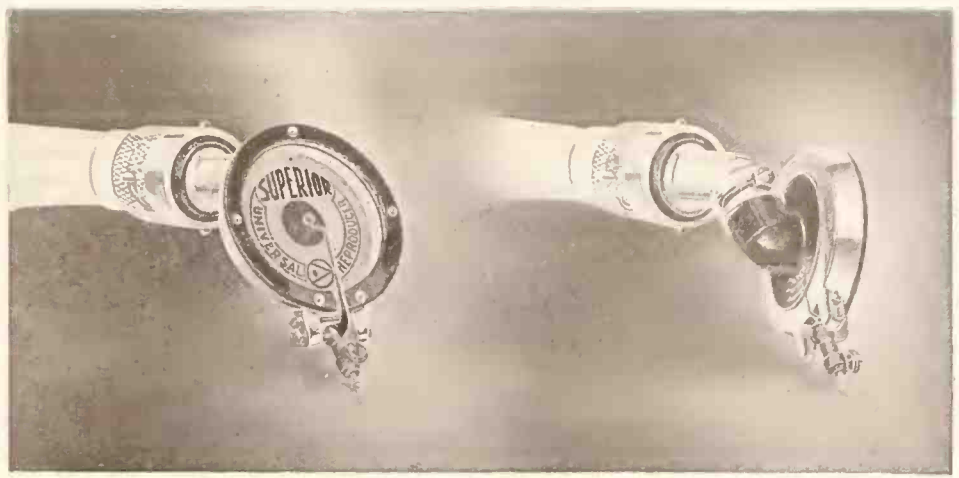

Superior Universal Reproducer on the Edison

The Ideal All-Record Reproducer for the Edison Disc Phonograph

Superior Reproducer with 21-E Connection for Edison—Sample Prepaid to Dealer, \$4.75 Nickel—\$6.25 Gold
Retail Prices, \$7.50 Nickel—\$10.00 Gold
Quantity Prices on Application



Superior Specialties for Phonographs
BARNHART BROTHERS & SPINDLER
Monroe and Throop Streets CHICAGO

showed receipts of \$111.47, all of which was disbursed in expenses, attorney's fees and other costs, so that creditors receive nothing from the proceeds of the sale.

Columbia Activities

Columbia records continue to make new high-water marks for volume of business, according to Robert H. Walley, representing the Chicago branch of the Columbia in Milwaukee and eastern Wisconsin. The Grafonola, likewise, is making excellent headway, due to the good work which has been done in educating the retail sales organization in this territory and the stimulation given the dealers.

Branch Factory for Lampagraph

The American National Mfg. Co., of St. Louis, a large maker of combination parlor lamps and phonographs, has recently purchased the foundry and machine shops of Slater & Tuck, at Beloit, Wis., for \$60,000 and will use it for a branch plant. The "Lampagraph" will be featured in a bigger and broader campaign than heretofore since a much greater production has thus been effected. Martin Wiegand is manager of the new Beloit plant.

After Fake Sales and Advertising

The Better Business Bureau of the Milwaukee Association of Commerce, which is under the vigorous direction of Oscar H. Morris, member of the State Senate of Wisconsin, reported, in a special bulletin, a few days ago: "Strenuous efforts are being made to prohibit 'fake' talking machine advertisements. Stores and manufacturers are complaining that 'gyp' artists are using private homes and downtown offices to get rid of instruments, some of which are misrepresented in the advertising. The police and the newspapers are co-operating with this Bureau to prevent such practices."

Helping to Boost Mitchell Street

Mitchell street, the "Grand avenue" of Milwaukee's south side district, is to be given a new and higher dignity and its business houses projected prominently into view through a campaign inaugurated by the Mitchell Street Business Men's Association, which includes a great many dealers in talking machines and other musical instruments. Among others are the J. B. Bradford Piano Co., Kunzelman-Esser Co., Edward Schuster & Co.'s south side department store,

Peter F. Piasecki & Co., and numerous others. Joseph T. Esser is president. One of the plans under way is to adorn all highways leading into the south side with signboards boosting Mitchell street as a trade center.

NEW CABINET COMPANY CHARTERED

United Cabinet Co., Chicago, to Make and Deal in Pianos, Talking Machines and Cabinets

CHICAGO, ILL., November 8.—The United Cabinet Co. has been incorporated here with capital stock of \$50,000, to engage in manufacturing and dealing in pianos, talking machines and cabinets. The incorporators are Nicholas Keaslering, John Lay and Carl Knittle. The factory of the company will be at 780 Milwaukee avenue. Carl Knittle, one of the incorporators, is a high-grade cabinet man and woodworker, and was for years with the Knittle Co. in Quincy. The others are also skilled mechanics prominent in this city.

CABINETS
WITH OR WITHOUT EQUIPMENT

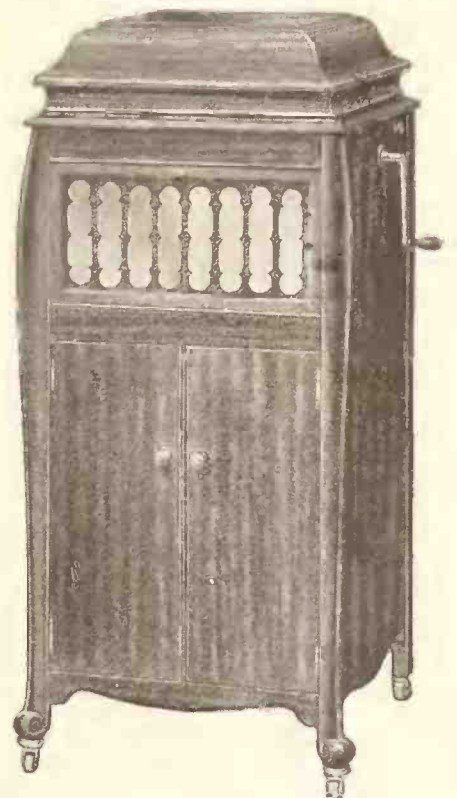

These High Grade Cabinets, made in Mahogany, Walnut and Oak, built up to the standard for which our product is noted.

For Descriptive Matter Address
FUEHR & STEMMER PIANO CO.
2701 So. Wells St., Chicago

Free—Individual advertising "helps" constitute but a part of the "Badger Service"

Badger Talking Machine Co.

Victor Distributors for
Wisconsin and Upper Michigan

135—2nd Street

Milwaukee, Wis.

The Last Word in Electric Phonograph Motors

Make this *your*
leading line for
the coming
season

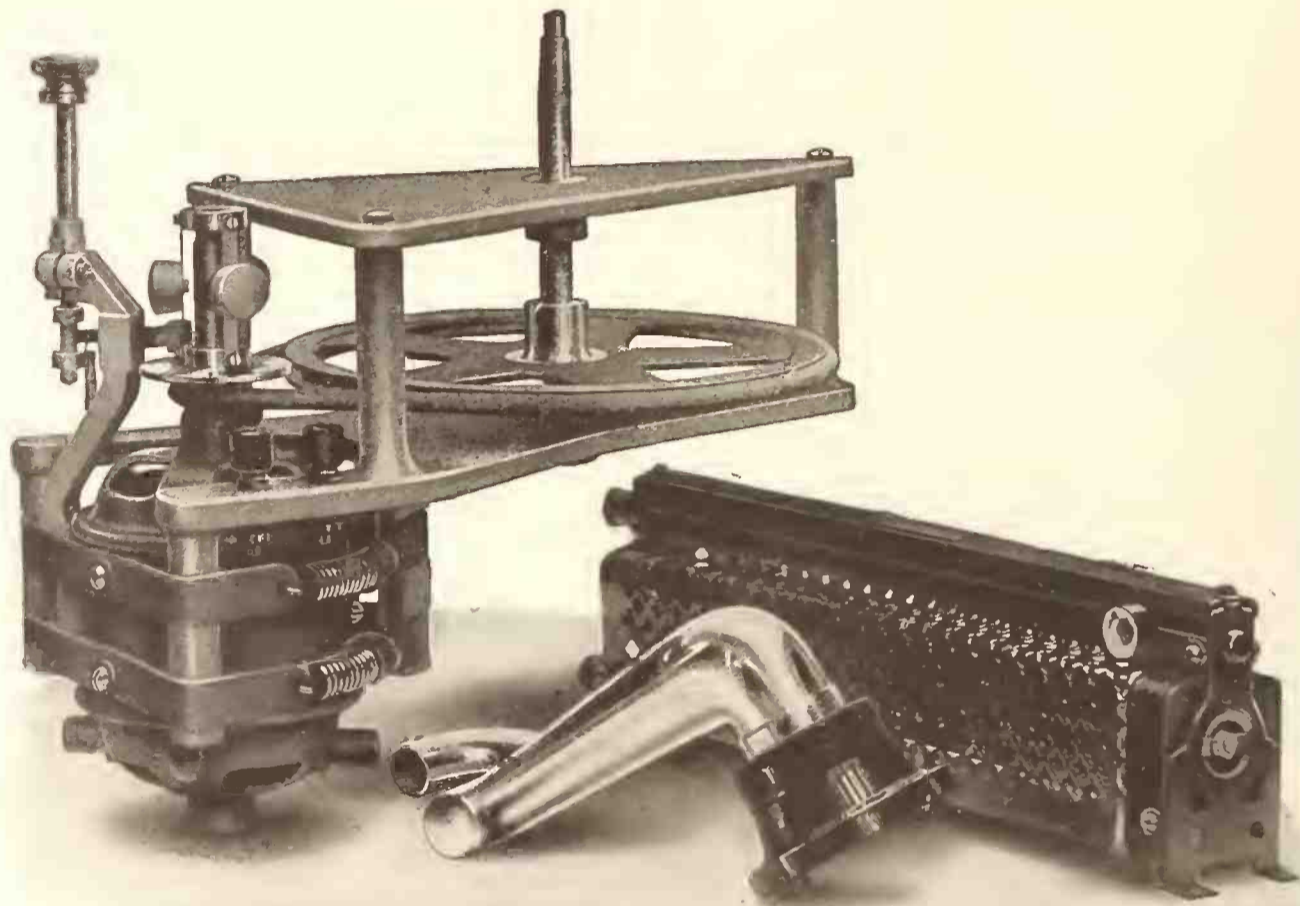

The Electromophone

Absolutely Silent

Adjustable to any voltage. Tone arm equipped with electrical stopping device, which operates in conjunction with the Electromophone—Record stops automatically on last note—Never fails!!

The Sole Selling Rights of This Unique Mechanism Are in the Hands of

THE STERNO MANUFACTURING CO.

19 CITY ROAD

LONDON, E. C., ENGLAND

The bluest blues Marion Harris ever put over are "The Memphis Blues" and "Beale Street Blues." Your customers will play them fast and frequent—and their friends won't rest till they get the record, too. A-3474.



Columbia Graphophone Co.
NEW YORK

JOBBER'S ASSOCIATION COMMITTEES

President Buehn Announces Personnel of Committees to Act During Current Year

Louis Buehn, president of the National Association of Talking Machine Jobbers, has just announced his appointments of committees to serve that organization during the coming year, the appointments being as follows:

Arrangement committee: Thomas F. Green, chairman; Floyd Spencer, Fred P. Oliver, Albert Weymann and Victor Moody.

Legislative committee: J. N. Blackman, chairman; L. C. Wiswell and E. H. Droop.



Thos. F. Green, Chairman, Arrangement Com.
Membership committee: W. F. Davison, chairman; John Elliott Clark and E. W. Rewbridge.
Press Committee: Dan Creed, chairman; Fred P. Oliver and T. W. Barnhill.
Resolution and referendum committee: French Nestor, chairman; W. P. Dierks and Fred Putnam.
Traffic committee: E. C. Rauth, chairman; W. H. Reynolds and Charles North.
Golf committee: J. C. Roush, chairman.

CHAMBERLAIN BOOKS MANY ORDERS

BOSTON, MASS., November 7.—A. W. Chamberlain, factory representative for New England, with headquarters at 26 Broad street, is finding an increasing call for his line of specialties, which include record albums as manufactured by the New York Album & Card Co., delivery record envelopes as made by the Record Envelope Factory of Rumford, Me.; also record cabinets as made by Schloss Bros., of New York. Mr. Chamberlain is spending considerable time in the New England territory just now and orders for a good Fall business are accumulating fast, he says.

VICTORITES HONOR WHITEMAN

Nearly 200 New York Wholesalers and Dealers Make Up Theatre Party at the Palace as Tribute to Paul Whiteman and His Orchestra

Nearly 200 Victor wholesalers and dealers of New York and vicinity, with members of their staffs, attended the performance at the Palace Theatre on Friday evening, October 27, in honor of Paul Whiteman and his Palais Royal Orchestra, who are just completing their fourth consecutive week at that leading vaudeville playhouse.

Through the efforts of Hugh C. Ernst, sales manager of the New York Talking Machine Co., several of the boxes and a number of front orchestra chairs were filled with Victor enthusiasts, who thoroughly enjoyed the preliminary show, but saved a big welcome and applause for Whiteman and his men when they appeared, at about 10:30.

The orchestra rendered its regular program, typically Whiteman, and after an encore or so the curtain was dropped. The audience would not accept the finish, however, and finally forced the raising of the curtain and still another encore from the orchestra. As a last desperate effort, to enable the show to proceed, Whiteman himself stepped out before the drop and thanked his friends, and particularly the "Victor people," for the very enthusiastic reception. He called it a speech and thus made good on a promise he had made to Mr. Ernst early in the week. Whiteman also took occasion to announce that he had been booked for the following week, making the fifth week of his engagement at the Palace—a most unusual record.

After the show a goodly number of the talking machine men and their ladies, who still hungered for the Whiteman melodies, adjourned to the Palais Royal and spent several hours in enjoyment of the entertainment provided at that Broadway resort. It was a big night from every point of view.

CARDINAL PHONOGRAPH CO. MOVES

General Sales Headquarters Moved From Zanesville to Cincinnati—F. F. Dawson, of the Sterling Roll & Record Co., in Charge

CINCINNATI, O., November 3.—The Cardinal Phonograph Co., of Newark and Zanesville, O., has transferred its general sales headquarters from Zanesville, O., to this city, where offices have been opened at 137 West Fourth street. These offices are under the excellent supervision of F. F. Dawson, president of the Sterling Roll & Record Co., who was formerly branch manager of the Columbia Graphophone Co. It is announced that Mr. Dawson will continue his direction of the Sterling Roll & Record Co., of this city and Pittsburgh. Mr. Dawson is well known and liked throughout the trade in his territory. The arrangements were concluded between F. F. Dawson and George Hayden, president, and George Hayden, Jr., secretary and treasurer, of the Cardinal Phonograph Co.

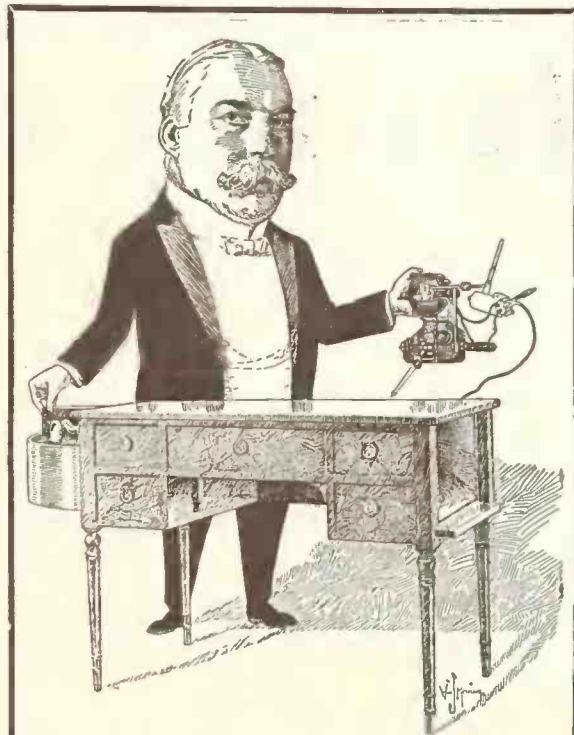

We Challenge Comparison

Exclusive Patented Features, Attractive Library Table and Phonograph Combined.

The exquisite tone of this new patented Clayola Phonograph distinguishes it from all other phonographs.

The foundation of artistic worth in a phonograph is mechanical excellence. Painstaking care to secure perfection in every detail of construction. The most artistic, the most useful of all phonographs. We have added to the cost of this table money which might have been added to our profits.

My idea of introducing the new style Clayola is not to make the most profit but to make the best phonograph.

We are more than sure of your approval of the exclusive patented features of major importance, features other phonographs do not have.

We can furnish these library table machines in the William and Mary period if you desire.

Attractive prices to dealers forwarded on application.

THE PHONOMOTOR

The standard electric phonograph motor for seven years. Universal motor, A. C. or D. C. current, 110 volts, with current consumption of less than a twenty watt lamp. Automatic stop.

Always true to pitch. Silent, durable and dependable. Write for our new prices.

GEO. CLAY COX

Manufacturer

Offices: 73 State St.
ROCHESTER, N. Y.

BIG HOLIDAY TRADE EXPECTED BY DEALERS IN BUFFALO

Every Indication Points to This Conclusion—Talking Machine Men Attend Festival at Sharon—Association Banquet November 16—New Stores and Changes—Trade Situation Analyzed

BUFFALO, N. Y., November 9.—A good holiday business is anticipated by Buffalo talking machine men. All signs point toward it, they say. The way trade has picked up recently fills them with optimism over the future. Throughout the Fall business conditions in Buffalo have been steadily improving. The volume of sales has constantly been on the up-grade. The employment situation here is very much improved, and the chances are that it will be still better as Christmastime draws near. Big plants are increasing their forces in large numbers. Dealers report that collections are better and that the demand for records has picked up. C. N. Andrews reported large advance orders for Victor records of various popular numbers, including "Ma," "Wabash Blues," "My Sunny Tennessee," "Tuck Me to Sleep in My Old 'Tucky Home" and "Second-hand Rose." The Columbia branch here tells of

big sales of "Sunny Tennessee," "Ma," "Say It With Music" and "All by Myself," Ted Lewis' rendering of the last-named making an especial hit. The Brunswick dealers state that there is a strong demand for "Wabash Blues" and "Ma."

Victor dealers here report a big demand for the new "300" type of machine. They state that they are not able to supply this style fast enough, so strong is this demand.

The manager of the local Brunswick branch informs *The World* that the three new console types are proving very popular in Buffalo.

An interesting music festival was held the week of November 7 at the store of W. C. De Forest & Sons, Sharon, Pa. This is the third festival of this kind, an annual affair, which has been held at the store. There were special days for various nearby cities in which the concern has stores—Warren, Sharon and Greenville, Pa., and Niles,

O. Managers of the stores in these towns brought large delegations to the festival on these days. Some splendid Victrola concerts were among the features of the week. Mr. and Mrs. C. N. Andrews and C. M. Logan, traveling representative of the Victor Co., were visitors at this festival.

The Kurtzmann music store, now located at Main and Goodell streets, will be moved into the Pierce Building as soon as that structure, now being erected, is completed. The new store will be a spacious one and much attention will be devoted to making it one of the finest talking machine departments in the city. This move gives the store a location further downtown. The Pierce Building is located in Main street, near Chippewa street, in a rapidly developing section.

The Buffalo Talking Machine Dealers' Association will hold a banquet November 16 at the Ellicott Club. Final preparations are being made to have the dinner a monumental success and a large attendance is expected. At this dinner the name of the organization will be changed to the Victor Talking Machine Dealers' Association of Western New York.

Another of the Landau music stores has been opened at Pittston, Pa. This is one of the finest stores in that section of the country. It is an exclusive Victor store. There are a large number of record booths.

Charles Heinike, manager of the Victrola department of Denton, Cottier & Daniels, has been passing out cigars and receiving congratulations from his many friends. He is the proud father of a fine young son, his second.

George F. Crossmire, of the Kane Furniture Co., of Kane, Pa., well known also as a talking machine dealer, died recently. He had been ill for about two years. He had many friends in the trade.

The Stramburg Music House, at Jamestown, is being remodeled and enlarged. Elwin Glantz, formerly of Danielson's Music House, at Jamestown, will have charge of the Victrola department.

Robert Porter, field sales manager of the Columbia Graphophone Co., was the principal speaker at an interesting sales conference, which was held at the Columbia branch in this city on November 1.

When Mary Garden and Geraldine Farrar visited Buffalo recently many of the dealers found new business by featuring their records. A Columbia artist, Cyrena Van Gordon, was among those here during the week of the American Music Festival, which was held October 3-8. Fritz Zimmerman, Swiss yodler, another Columbia artist, has been giving a number of concerts in the Buffalo territory recently.

With the assistance of one of the company's educational representatives and Assistant Manager Peace, a Buffalo Columbia dealer was successful in securing a contract to place a good-sized number of Pushmobiles and Grafonolas in the Buffalo public schools for educational purposes.

William Spalding & Co., Columbia dealers at Syracuse, have just completed the remodeling of their store, which includes a complete and up-to-the-minute Van Veen installation of hearing rooms and equipment.

AT AMERICAN LEGION CONVENTION

PHILADELPHIA, PA., November 3.—L. Hammond Crabtree, assistant sales manager of the diaphragm department of the International Mica Co., of this city, attended the convention of the American Legion at Kansas City, Mo., held during the early part of this month. At the close of the convention Mr. Crabtree went to Chicago and worked his way back to headquarters in this city, calling upon the Middle Western talking machine manufacturers, and others, en route. Mr. Crabtree is taking up with the various manufacturers their requirements for 1922, in order that his company may know exactly how to approximate next year's possibilities in advance on account of importation from India.

If your nose is on the grindstone of your own business it isn't in other folks', anyhow.

It's not too late—

Last minute orders on Bubble Books get express service!

Dealers whose stocks have run low—dealers who haven't a Bubble Book in the house—can order now and have a complete selling display for the buying weeks.

BUBBLE BOOKS "that Sing"

nationally advertised—well made—a new low price. 3 big features, colored pictures, fairy stories and 3 phonograph records which sing the songs in the books.

Your order today means a big Christmas sale that will continue throughout the year.

"When You Sell One You Sell A Habit."

Order now.

HARPER & BROTHERS

Bubble Book Division

130 West 42nd Street

New York

TRADE OPTIMISTIC IN CANTON, O.

Opening of Steel Plants Helps Sales Campaign—Rhines Edison Shop Opens—Need of Association Activity—Some Interesting Reports

CANTON, O., November 4.—With the steel industry decidedly on the up grade, there is a better tone in business and more confidence among music dealers of this and nearby towns. Steel plants in the Canton-Massillon district, with but few exceptions, are humming again and hundreds of the unemployed are being absorbed. Money is becoming freer and merchants in downtown Canton say business as a whole looks brighter. Music dealers, like merchants of other lines, believe normalcy is near and that the depression is gone for good.

Right at this time few dealers can definitely say just how they will be fixed for Spring, but the majority of the leading stores are planning to purchase more liberally than a year ago, claiming that the business is in sight and that they were perfectly willing now to tie up capital, since there is a change to realize from it.

Invasion of the Cleveland avenue Northwest retailing center this week by the Rhines Edison Shop is one of the most important developments in the music industry locally. This shop, while small, is one of the most attractive in the city. It is the first in Cleveland avenue, but according to information available at this writing there will be others soon, as the North Market street rentals, where several of the old stores are located, are not being lowered as store proprietors have requested, and several are contemplating moving to Cleveland avenue as soon as store quarters are available.

C. M. Alford, head of the Alford-Fryar Piano Co., which firm sells perhaps more talking machines than any other piano shop in the city, reports that he is unable to get a sufficient number of Cheney talking machines. His books show at least a score of sales that have been made, but the machines to date have not been

forthcoming. Mr. Alford says the talking machine business is spirited and that record sales are holding up well. Collections are slow in many instances, but with industrial conditions gradually improving he looks for betterment in this respect in months to come.

The revival of the Canton Music Trades Association is looked for in the near future. S. S. VanFossen, of the VanFossen-Smiley Piano Co., says that there has never been a time when the co-operation of the music dealer was more needed than at present. He says if some of the other dealers do not soon start something he will take the initiative in reorganizing the association of music men in Canton. Mr. VanFossen was prominently identified with the Akron Music Trade Association prior to his coming to Canton from Akron. "It is the only way to keep in touch with the music trade situation locally, and the exchange of ideas and the good fellowship obtained from the meetings will do more toward making the music trades fraternity progressive than any other one thing of which I know," said Mr. VanFossen.

The D. W. Lerch Piano Co. is now featuring Brunswick records, a line which formerly was carried by the Canton Phonograph Shop, in Market avenue South, which was owned by George C. Wille. The Lerch Co., which also specializes in Columbia and Vocalion records, reports sales very good for October and that indications point to better sales in this department in November, as there are more real hits among November record lists.

"The dealer who does a satisfactory talking machine business at this season of the year must have a hustling sales organization," says George C. Wille, head of the George C. Wille Co. "What business is available must be gotten through the efforts of the salesmen and this means that a live organization is essential if the house is to benefit." Collections are better this month, Mr. Wille says, and, while he believes there will be a decided change in the trend of business later in the Winter he feels that Novem-

A RECORD RACK

Particularly for **DEALERS IN WARM CLIMATES**

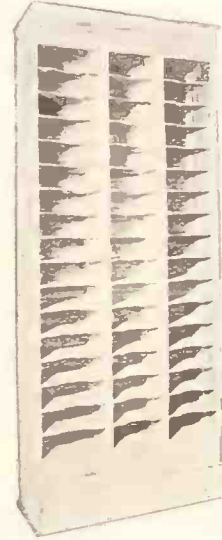

Vertical racks cause warped records.

Warped records are a dead loss.

This handsome horizontal rack holds 400 twelve inch, and 800 ten inch records, in addition to drawer space, occupies an area only 1 foot by 3

feet, 8 feet high, solid dustproof back, enamel or mahogany finish; ready for shipment; write for price.

VAN VEEN & COMPANY

Hearing Rooms, Record Racks and Counters

47 West 34th Street, New York City
1711 Chestnut St., Philadelphia, Pa.

ber will be a better month. He reports business with his Massillon, O., store continues to be very satisfactory.

A great many salesmen seem to be quite voluble in the way of ideas, but, strange to say, they do not always put them in practice in the stores where they are employed. We wonder why!

A Quality Record—Made for Quick Sales



SOME OF THE NEW RELEASES

- "Song of Love"
- "Salomay"
- "Wabash Blues"
- "Everybody Step"
- "I Want My Mammy"
- "Birds of a Feather"
- "I Got the Red, White and Blues"
- "April Flowers"
- "That's How I Believe in You"

Popular hits mean sales—continued sales where the record is one of quality. Clarion gives you the latest songs at once—you cash in regularly with every release because it is a record giving your customers satisfaction.

Build up a steady record trade by arranging now for a Clarion agency. We will be pleased to show you how.

*Clarion Offers Immediate Deliveries.
Jobbers and Dealers, Write.*

CLARION RECORD COMPANY

56 BLEECKER STREET

NEW YORK CITY

COLUMBIA ADVERTISING CONTEST

Columbia Graphophone Co. Announces Unique Contest for Columbia Dealers—Prizes Will Be Awarded for Most Effective Advertisements

The Columbia Graphophone Co. has just announced a dealers' advertising contest that is one of the most unique and interesting contests introduced in the talking machine trade for some time past. The contest, which started on November 1 and will run until December 1, is open to every Columbia dealer in the United States. The provisions of the plan state that all advertisements entered in the contest must be exclusively Columbia and must carry the Columbia trademark. In order to enter this advertising contest a dealer must place in his local paper at least four advertisements during the month of November 1 to December 1.

Every advertisement of any size which any Columbia dealer places in any paper in the United States as part of such a four-or-more advertising campaigns between November 1 and December 1 is eligible for one of the prizes. In order to enter his advertising in this contest a dealer must tear out the complete pages containing each advertisement in the month's campaign and mail them all to the advertising contest committee of the Columbia Graphophone Co. at the Gotham National Bank Building, New York.

These advertisements must be received on or before Wednesday, December 7, and the advertisements should not be torn or clipped from the newspaper page, as only complete pages showing the advertisements will be accepted as entries. The advertisements entered in the contest will be judged by one point only and that is "selling punch." The judges of the contest will be Frank E. Fehlman, president of the Advertising Club of New York; James O'Shaughnessy, executive secretary of the American Association of Advertising Agencies, and V. Burnett, associate editor of Advertising and Selling.

The prizes to be awarded in this contest are

BE PREPARED for the HOLIDAY RUSH

A good, serviceable table machine at a moderate price is the greatest value on the market today.

Our "Fulton" Model 35 Phonograph is just what you have been looking for.

Lower Than Pre-War Prices

Samples now \$13.50, Three or more \$12.50



Highest grade domestic steel needles at 30c per M. Discount in large quantities.

Phonograph records, accessories and repair parts for all makes at lowest prices. Ask for catalog on our Floor Cabinet machines.

Mahogany, 16x16x10, Double Spring, Universal T. A. Back Casting and Metal Horn

SEND in your order today and make sure of immediate deliveries before the big Christmas rush starts.

Terms: Cash or deposit with order, balance C. O. D.

FULTON TALKING MACHINE CO.

253 Third Avenue,

New York

as follows: First prize, free advertising space in the winning Columbia dealers' local newspapers totaling six times the space of the winning advertisement. This space must be used between December 14 and December 25, 1921. Second prize: free advertising space totaling five times the space of the winning advertisement; third prize: free advertising space totaling four times the space of the winning advertisement; fourth prize: free advertising space totaling three times the space of the winning advertisement; fifth prize: free advertising space totaling twice the space of the winning advertisement; sixth prize: free advertising space totaling the same size as the winning advertisement.

The names of the winning dealers and the newspapers in which the winning advertisements appeared will be announced on Friday, December 9. Notification will immediately be sent to all prize-winners so as to give them ample opportunity to use the free advertising space they have won between December 14 and December 25.

The Columbia Graphophone reserves the right to use the prize-winning advertisement, with proper credit to the winners, in its monthly portfolio of advertising for Columbia dealers and its house organ, Columbia Record.

REORGANIZE EBERHARDT-HAYS CO.

Frank D. Hays Retires From Old Wichita Music House—Three Former Employes Buy Interest and Assume Executive Positions

WICHITA, KAN., November 1.—The interest of Frank D. Hays, of the Eberhardt-Hays Music Co., 132 North Main street, this city, the oldest concern in this vicinity, will be taken over in the near future by Carl Miltner, W. A. Forgey and W. W. Cunningham, all of whom have been with the company for a number of years.

Mr. Hays, who has been in the music business here for the past eighteen years as a member of the Eberhardt-Hays Music Co., is forced to give up the business on account of ill health, which makes it necessary for him to enter some enterprise where the greater part of his time will be spent outdoors.

Immediately following the retirement of Mr. Hays the business will be entirely reorganized. The name of the company will remain unchanged. Under the reorganization plan Mr. Eberhardt will continue as general manager. Mr. Cunningham, who is now in charge of the company's store in Winfield, Kan., will act in the capacity of assistant manager; Mr. Forgey will assume management of the Winfield store and Mr. Miltner will have charge of the sales and tuning and repair departments.

E. C. HOWARD IN OAKLAND

OAKLAND, CAL., November 10.—E. C. Howard, formerly with the Granby Phonograph Corp. of Norfolk, Va., arrived in this city to-day, where he plans to sojourn for a period with Mrs. Howard and daughter, Janet. Mr. Howard's future plans are as yet unsettled, but, after a brief rest in his native State, it is expected Mr. Howard will again place his remarkable organizing ability at the disposal of the industry.

Your mailing list is worthless until you sow the seeds of sales and cultivate follow-ups.

WARNING

Wall Kane Needles Are Being Imitated

WALL KANE NEEDLES

are the standard, trademarked needles of the phonograph industry. They are guaranteed to play ten records without injuring the grooves, the last record playing as clear as the first.

Beware of Imitations

Inquire for our new jobbing proposition

The Greater New York Novelty Co.

3922 14th Avenue

Brooklyn, N. Y.

GLEANINGS *from the* WORLD *of* MUSIC

DISTRIBUTORS' SERVICE FOR TALKING MACHINE DEALERS

Simplified Plans Arranged to Aid Talking Machine Dealers Operating or Intending to Operate Sheet Music Departments—Kronberg Offers Numerous Suggestions of Distinct Value

Various sheet music distributors in the country have recently arranged plans to give particular service to talking machine dealers operating or intending to operate sheet music departments. These are simplified plans which help to induce dealers to stock such goods which prove most inviting.

Several hundred dealers in the New York district, within the last eighteen months have equipped their stores with music racks for the display and sale of sheet music and in practically every instance they have found such goods a profitable adjunct to their business.

At the October meeting of the Talking Machine Men, Inc., the well-known organization of talking machine dealers of the metropolitan district, Sol Kronberg, of the Plaza Music Co., outlined a plan for opening such departments in a most simplified form and involving an investment of as low as \$100.

In his address Mr. Kronberg offered many reasons to show that the average talking machine store was the logical place for the sale of sheet music, which in no wise detracted from the exclusiveness of the establishment.

He made it very clear that with the present wholesale and retail prices there is a 25 to 30 per cent net profit on such goods—averaging 50 per cent on cost. This is, indeed, a substantial revenue when it is considered that such departments in no wise interfere with the sale of

other goods—require little or no attention—and with up-to-date music racks practically act as silent salesmen.

Among other things, he impressed the dealers with the advertising value which accrues to the store operating such racks, his argument being that sheet music is, after all, a magnet and, irrespective of the profits, which are quite substantial, has value to the dealer that can not be lightly overlooked. Mr. Kronberg further pointed out that the dealers conducting popular music departments in talking machine stores were doing so without increasing their overhead; for the music makes for larger business, requires little or no space and, being a cash business and a rapid turnover proposition with hits released at frequent periods, creates activity in any store.

One point of particular interest brought out in the discussion was the advisability of dealers who are located near theatres watching the current programs at the playhouses. This enables the dealer to arrange window displays of records and sheet music of selections that are being featured at the theatre each week, and thus encourage direct sales to members of the audience. By this method, too, it is possible frequently to move records and music that might otherwise remain on the shelves indefinitely.

There is some question regarding just how much the orchestras and vaudeville people contribute to the popularity and salability of rec-

ords, but it is the general opinion that the exploitation of the sheet music itself has a strong effect on record sales. Thus it seems logical for the talking machine dealer to turn to sheet music in his efforts to increase business.

Practically all dealers and distributors of sheet music, in encouraging talking machine dealers to open popular sheet music departments, make it a point to suggest the purchasing of such goods through a central source. Thus purchases from some thirty music publishers can be made by a single order and depleted stocks can be replenished, generally over night.

Among the leading music jobbers are: Plaza Music Co., New York; Crown Music Co., New York; F. J. A. Forster, Chicago; McKinley Music Co., Chicago; J. W. Jenkins' Sons Music Co., Kansas City, Mo.; Sherman, Clay & Co., San Francisco, Cal.

SONG HITS IN "UP IN THE CLOUDS"

New Musical Comedy Soon to Complete Tour and Make Broadway Debut

"Up in the Clouds" is the title of a new musical comedy produced by the Shuberts, which has played successful engagements in Chicago, Cincinnati, Indianapolis and Detroit. It is also to play engagements in Cleveland and Pittsburgh, shortly after which it will have its Broadway premiere. The leading songs of the show are "Up in the Clouds," "Happiness" and "I See Your Face in Every Nook and Corner." The Crown Music Co. is the sole selling agent for the music.

The Most Talked-About Song since "MISSOURI WALTZ"

"MISSISSIPPI CRADLE"



Rock me in my Mis - sis - sip - pi Cra - dle,



Let me look in - to my mam - my's eyes;

FORSTER
MUSIC PUBLISHER INC.
235 SOUTH WABASH AVE.
CHICAGO

Published by the publisher of "MISSOURI WALTZ," "NAUGHTY WALTZ," "SWEET AND LOW," "KISS A MISS"

FOUR HITS from the GREATEST MUSICAL SHOW EVER PRODUCED
IRVING BERLIN'S "MUSIC BOX REVUE"

"SAY IT WITH MUSIC"

"THEY CALL IT DANCING"

"EVERYBODY STEP"

"THE SCHOOLHOUSE BLUES"

FOUR HITS FROM THIS SEASON'S MOST ACTIVE CATALOG

"BIRDS OF A FEATHER"

"SWEET COOKIE"

"TUCK ME TO SLEEP IN MY OLD 'TUCKY HOME"

"WHEN THE SUN GOES DOWN"

IRVING BERLIN, Inc., 1607 Broadway, New York

TRUST FUND FROM RECORD SALES

Ethel Lee Buxton, Soprano, Evolves New and Clever Method for Raising Money for Benefit of the Veterans of the World War

KANSAS CITY, Mo., November 4.—A trust fund of \$100,000 for the benefit of disabled soldiers and the survivors of those who have died has been created by Ethel Lee Buxton, well-known soprano of this city. The fund, it is said, will be made up of the proceeds of the sale of Columbia phonograph records made in New York recently by Miss Buxton, the selections being "Leave It With Him," "Let's Have a Moment's Silence for the Boys Who Died for You" and "Can't You Hear Me Calling, Caroline?"

Miss Buxton sang and assisted in hospitals in France for over eighteen months and is said to have been the first woman to sing "The Star Spangled Banner" on the Rhine. She is a member of the William T. Fitzsimons Post of the American Legion, which has been made trustee of the fund, with Hugh F. Reilly, a local attorney, as chairman of the trustee committee. The records are to be sold for \$2, of which \$1.50 goes to the fund.

Paul Althouse, who is considered by some to be the foremost American tenor, is singing with success the Sam Fox Publishing Co.'s song, "I Love You More," the work of Dorothy Lee, composer of "One Fleeting Hour," and other ballads of the better class.

ORCHESTRA WINS CONTEST

Charles de Hart Orchestra Wins Atlantic City Contest, Using "Frankie"

Herewith is reproduced a photograph of the Charles de Hart orchestra which won this sea-



The Charles de Hart Orchestra son's contest held at Strickland's Million Dollar Pier, Atlantic City, N. J., in competition with a large number of orchestras. The prize cup shown in the photograph was won by playing

the successful fox-trot "Frankie," published by the Jack Snyder Music Co., New York City.

The Charles de Hart orchestra is composed of nine young men who have not as yet gained a national reputation, but with the success the organization has met with during the past season it bids fair to become quite prominent.

"SHIP O' DREAMS"

Concert Artists Using New Song From the Sam Fox Catalog With Success

"Ship o' Dreams," from the catalog of the Sam Fox Publishing Co., New York and Cleveland, O., has been received so well by concert artists everywhere that the publisher, in addition to the publicity already issued in behalf of the song, will inaugurate a special campaign during the coming months. This number, which appeared in the November releases of the Victor Talking Machine Co., a record by Merle Alcock, seems to be most favorable material for the better class artists.

People buy where they get courteous service.

THE COUNTRY'S QUICKEST "BLUES" HIT

EVERYWHERE IS HEARD THE

Ta De Da Da De Dum



Already obtainable for player-piano and any talking machine

Publishers **J. W. JENKINS SONS MUSIC CO., Kansas City, Mo.**
 Also Publishers of "12th Street Rag," "Sweet Love," "Colleen O'Mine"



TON RECORD SALE PROVES SUCCESS

Columbia Dealer in Florida Features "Nobody's Baby" to Advantage—Window Display Produces Results—A Successful Campaign

JACKSONVILLE, FLA., November 7.—The Forsythe Graphophone Hall, of this city, a successful retail establishment handling Columbia products, recently introduced a ton record sale, featuring "Nobody's Baby," which was a tremen-



Forsythe's Special Window

dous success. Through a fortunate coincidence a representative of Leo Feist, Inc., the well-known music publisher, was in Jacksonville during the sale, co-operating with Manager Fiske, of the Forsythe Hall, in making the sale a success. A piano player hired by the publisher's representative played the song day and night and a Magnavox placed on top of the piano added to the volume of the playing.

The window display was appropriate to a de-

gree, as in one part of the window a beautiful doll was seated on a large chair with a card announcing that she was "Nobody's Baby." At the right of the window was a baby carriage,



How Public Was Interested

with another doll gazing at the public, and a large tag identified this doll as "Nobody's Baby." The owners of the Forsythe Graphophone Hall were highly pleased with the results of the sale and heartily endorsed the idea as an advertising plan and effective business producer.

AD FEATURES "DANGEROUS BLUES"

The J. W. Jenkins' Sons Music Co., Kansas City, Mo., inserted early this month an advertisement in the New York Times, the copy of which featured the song and instrumental success, "Dangerous Blues." The Victor record of this song, made by the original Dixieland Jazz Band, was given special prominence and the Brunswick, Columbia, Okeh and Arto records, with descriptive material, were mentioned.

When in doubt, let the other fellow talk. He may tell the truth, y' know!

"THE ROSE GIRL" OPENS IN BOSTON

Musical Numbers Published by M. Witmark & Sons Prove Popular With Audiences

"The Rose Girl," the musical play which was quite a success at the Ambassador Theatre, New York, last season, recently had its first opening of the second season at the Wilbur Theatre, Boston, Mass., where it is scheduled for an extended run. This is the work of William Cary Duncan and Anselm Goetzl and has some musical numbers that are making a marked impression. These include "There Comes a Some Day," "Dear Little Rose Girl," "Down Where the Mortgages Grow" and "In the Heart of My Crimson Rose." This latter is from the pen of Shep Camp. The music of "The Rose Girl" is published by M. Witmark & Sons.

WRITES A NEW IRISH SONG

"Kitty O'Hare" is the title of a new Irish melody by Werner Janssen set to a characteristic lyric by Francis DeWitt. Mr. Janssen is very much in the limelight at the present time through his tuneful music in "Love Dreams," a Morosco production now running at the Apollo Theatre, New York. "Kitty O'Hare" is described as a musical Irish gem by Tom Burke, one of the foremost Irish singers, who is to program the number at his next Hippodrome concert. He has also recorded it for the Columbia Graphophone Co., which, it is understood, is going to release it as a special record. It is published by the Edward B. Marks Music Co., of New York.

THE YEAR'S CALENDER
 OF THE NEW HOUSE OF HITS
 One Every Month And Live Forever

JANUARY: LOVE IN LILAC TIME (INTERNATIONAL WALTZ HIT)
 FEBRUARY: PINING (FOX-TROT)
 MARCH: MOONBEAMS (NOVELTY FOX)
 APRIL: JAZZ ME BLUES (SENSATIONAL FOX-TROT SONG)
 MAY: IN A BABY'S HANDS (BALLAD)
 JUNE: WHO'LL BE THE NEXT ONE (TO CRY OVER YOU) (SENSATION BY WRITER OF DARDANELLA)
 JULY: SWIMMIN' HOLE (SUNG BY EVERY TURLINER)
 AUGUST: BABY FACE (JOE HOWARD'S FOX-TROT SONG HIT)
 SEPTEMBER: SAL-O-MAY (SALOME) (INTERNATIONAL FOX-TROT HIT)
 OCTOBER: DADDY YOUR MAMAS LONESOME (FOR YOU) (FOX-TROT SONG ALL TOP-LINERS)
 NOVEMBER: HONOLULU HONEY (\$5,000. FRISCO HAWAIIAN PRIZE WINNER)
 DECEMBER: WAIT UNTIL YOU SEE ME SUNDAY (HETTY KING'S SENSATION-WINTER GARDEN)

SEND FOR LIST OF SIX RUDY WIEBOEFT SAXOPHONE SOLOS

EDW. B. MARKS MUSIC CO. 102-104 WEST 38TH ST. NEW YORK N.Y.

Every Number Released by Leading Record and Roll Companies or in Preparation

"PRESENTED BY THE ORIGINATOR"

FRANKIE

DON'T BE LED ASTRAY



FOX-TROT
WRITTEN and PUBLISHED BY
JACK SNYDER
1658 BROADWAY, NEW YORK

SINGLE,
DOUBLE,
QUARTETTE,
& COMEDY
VERSION,
NOW
READY



FEIST PRODUCTION NUMBERS

Leo Feist, Inc., Publishing the Scores of Many of the Season's Theatrical Successes

Among the musical shows of which Leo Feist, Inc., publishes the music, and which would seem to demonstrate that that firm is becoming one of the most active publishers of music for such shows, are: "Tangerine," now playing an indefinite engagement in New York, the principal songs of which are "Sweet Lady," "Isle of Tangerine," "Listen to Me" and "In Our Mountain Bower"; the "Broadway Whirl," which is now on the road, of which "Oh, Dearie!" "Caring" and "Black-eyed Susans" are published by Feist; "Love Dreams," which recently opened up at the Times Square Theatre, New York, the song numbers of which are "Love Dreams," "Lonesome Boy" and "The World Owes You This"; "Blossom Time," now playing a New York engagement, the feature numbers of which are "Song of Love," "Serenade" and "Only One Love Ever Fills the Heart"; "Lily Dale," which will shortly play a New York engagement, the principal songs being "Mother's Wedding Dress," "The Little White House" and "Saw Mill River Road." Feist also publishes the songs "Snow Flake," "When Dreams Come True" and "Three o'Clock in the Morning," from this season's "Greenwich Village Follies," as well as the songs "Why Don't You?" "I Want Love" and "Julie," from "Afgar," now on the road, and, of course, the music for the four road shows of "Irene," the songs of which include "Alice Blue Gown," "Irene" and "Castle of Dreams."

MARKS NUMBER WINS SONG CONTEST

The Edward B. Marks Music Co.'s new number, "Down at the Old Swimming Hole," recently won a song test in competition with songs from the catalogs of a number of publishing houses. The contest was held at the Prospect Theatre, Brooklyn, N. Y.

AMERICAN MUSIC IN CHINA

Earl Curren's Orchestra Meeting With Great Success in Shanghai, China

It isn't generally known that American popular publications are played persistently and re-

these music missionaries, showing Earl Curren at the piano, and we are informed that they are rendering, or about to render, the Feist song success "Wabash Blues," having received one of the original manuscripts. Of course, they play other popular American publications and it would seem timely for those publishers who



Earl Curren's Famous Dance Orchestra in Action

ceive wide publicity in China. Offhand one would labor under the impression that American publications had little or no place in that country. The playing of a typical American song on a typical Chinese instrument would hardly be successful, but The World frequently receives programs showing that, despite all thoughts to the contrary, American publications are being played in China regularly.

This situation comes about by the fact that Shanghai, China, is, in many respects, quite Occidental, and it remains for the Astor House Hotel, of that Chinese city, to care for the musical taste of such people.

At the present time Earl Curren, who was formerly a piano player in the San Francisco house of Leo Feist, Inc., is the director of Earl Curren's Famous Dance Orchestra in the above hotel. We herewith reproduce a photograph of

have not already communicated with Mr. Curren to do so at once.

LOPEZ AT PENNSYLVANIA HOTEL

Vincent Lopez, well known as a director of orchestras and whose organization appeared throughout the Summer at the Ross-Fenton Farm, Asbury Park, N. J., recently signed a contract with the Pennsylvania Hotel, New York, whereby his enlarged orchestra will play there this season. The orchestra will be known as "Vincent Lopez and His Pennsylvania Orchestra."

Burns & Moreland have opened an attractive music establishment at Cameron, Mo. A complete line of Starr phonographs, records and pianos are handled. The store presents an attractive appearance.

ETHEL WATERS' Latest Record Is Now On Sale

It's Truly Great | **2021** { THERE'LL BE SOME CHANGES MADE | Full of Pep
ONE MAN NAN

THE Black Swan Troubadours, with Ethel Waters and her Jazz Masters, are now on tour through the East, South and Middle West. Her personal appearance in all the cities means an increased sale of Black Swan Records for the Dealer who is prepared to meet this demand. Ethel Waters will sing the above songs as well as Number 2010—*Down Home Blues*, the only hit of the season.



Place Your Order NOW and anticipate the demand. Immediate Delivery Assured.

PACE PHONOGRAPH CORPORATION
2289 Seventh Avenue New York, N. Y.

"SAY IT WITH MUSIC" BIGGEST HIT OF MANY YEARS

New Irving Berlin Number From the "Music Box Revue" to Be Released Simultaneously by Every Player Roll and Talking Machine Record Concern in the Country—Big Campaign Planned

The fact that every talking machine record and player roll manufacturing company has made mechanical reproductions of Irving Berlin's song, "Say It With Music," from the "Music Box Revue," and made a simultaneous release of this number on November 1, probably marks the first time in the history of the music business when a song was so universally released at a precise period.

Of course, at the same time the sales and band and orchestra departments of the publisher will also make a campaign on the number and the unusual publicity that it will receive in a short space of time will, without doubt, make it one of the most successful numbers of many seasons. The bands and orchestras are already assuring the publishers of their support.

In order to give the trade its best co-operation

Irving Berlin, Inc., has issued much advertising material in the way of show cards, hangers, pamphlets and a thirty-six-by-twelve window strip, a reproduction of which appears herewith.

"Say It With Music" is already recognized as one of the most active sellers of the present season and under the present plans and arrangements this most meritorious number, with the slogan of exceptional value to the music trade in general, will long continue in popularity.

The sales drive in behalf of the number will cover all the usual channels of publicity and in addition there have been inaugurated some unique sales methods which will add to the song's popularity. The trade is giving most unusual co-operation and well it should, as "Say It With Music" carries a message which will benefit the trade in ways other than the mere sale of the goods.

NEW SHERMAN, CLAY OFFICES

Richard Powers in Charge of New Headquarters in New York City

Sherman, Clay & Co. have just acquired a suite of studio rooms on the seventh floor of 56 West Forty-fifth street, New York, which, after some elaborate alterations, were opened as the New York offices of the company on November first.

Richard Powers, the Eastern representative of the above organization, will manage the new quarters and will have on his staff several assistants.

Sherman, Clay & Co. for several months have been trying to locate Eastern offices, but the high-class space which they desired, seemingly, was not available. The closing by Mr. Powers of a long lease at the above address marks the permanent entry of the organization into the New York field in both a professional and sales way.

The company is at present carrying on a campaign on the song "Have You Forgotten?" which is fast becoming a national hit. In addition, the number "Smilin'," as well as "Tio San" and "Tomorrow Land," is showing up actively.

Maurice Rosen, who for a number of years was manager of the Pittsburgh office of Jerome H. Remick & Co., is now Eastern sales manager of the concern and is also in charge of the mechanical reproduction department.

"TAKE HOME A RECORD"

Chicago Music Publisher Hooks Up That Slogan With Publicity Matter for the Talking Machine Dealers—Value of Direct Appeal

With a view to co-operating with talking machine dealers and stimulating the demand for records of various numbers, the Frances Clifford Music Co., Chicago, has introduced the slogan in its publicity matter, "Take Home a Record." The company has issued a number of slips for window display purposes upon which the slogan is prominently featured over the titles of the various numbers.

The new idea has met with favor from talking machine record dealers who have come in touch with it. The idea of featuring the descriptive matter issued by the publisher in talking machine stores to promote record sales is not new in any sense, but the idea of connecting with such matter the direct appeal to "take home a record" has an element of originality that should make it effective.

The Belwin, Inc., number, "I Want My Mammy," has been frequently used as the musical theme in the showing of the motion picture, "The Old Nest." The number is particularly adapted for the music to accompany the picture and, as in many cases it has been sung in conjunction with the showing, this has given the song some unusual publicity.

Business Is Good

There must be a special significance in the fact that throughout the Summer and Fall, and today, the lithograph plant of Einson Litho. has been running to capacity, with space and working force almost doubled over last year. Why?

The reasons undoubtedly are many, but we find that in these times of intensive selling effort the manufacturer considering window display and dealer helps insists on Ideas that will sell his goods.

Dignity, prestige, good-will are for days of an easier time. Today it is the Ideas that sell that make good.

So they come to the organization that has through years of experience learnt to catch the vital point about a piece of merchandise and embody it in a display or other dealer help that has a selling idea.

Call us in for ideas on your display material and dealer helps.

**EINSON LITHO
INCORPORATED**

Executive Offices, Art Studios and Manufacturing Plant

327 East 29th Street

New York City



"Arkansas Blues"
Classic Blues
A Down Home Chant
Snappy Toodle
Player Rolls, Sheet Music & Records

KIMBALL HALL
FRANCES CLIFFORD MUSIC CO.
"Publishers of Real Songs"

CHICAGO, ILL.

See Advance Bulletin
FOR
RELEASES
ON THIS
Big Selling Blues Hit
 and Order on Your Favorite RECORD

IN MAYTIME

(I LEARNED TO LOVE)

By **JACK SNYDER**



BAND
OR
ORCHESTRA
25¢

*Pronounced by
critics to be
The MOST
BEAUTIFUL
WALTZ
BALLAD
EVER
WRITTEN*

Published by **THE HOUSE OF MASTER COMPOSITIONS**
JACK SNYDER INC.
1658 BROADWAY, NEW YORK.

VICTOR HERBERT POPULAR

Composer Appearing at Leading Picture Houses
—Uses Witmark Selections

Victor Herbert, the well-known composer, is appearing in a novel role this season—that of "Guest Conductor" at some of the leading motion

picture houses. He is generally scheduled for a week's appearance and his programs are, of course, selected from his own repertoire of operatic and orchestral successes. He is proving a tremendous drawing card, which is substantiated by his recent appearance in Washington, which was the signal for a record-breaking attendance. Recently he appeared at the Strand Theatre,

New York. Among his selections are some from "Mlle. Modiste," "Eileen," "Babes in Toyland," "The Red Mill" and other Herbert light opera successes, the beautiful songs "Kiss Me Again," "Gypsy Love Song," etc., also such typical bits of Herbert melody and scoring as are to be found in "Panamericana," "Al Fresco," "Whispering Willows," etc., of which M. Witmark & Sons are the publishers.

GETS GOOD PUBLICITY

New Richmond Hit Featured Through Collaboration With Newspaper

Harry Engel, Chicago manager of Maurice Richmond, Inc., recently made a trip to Milwaukee, Wis., where, in collaboration with "Mr. X," of the Milwaukee Journal, he was successful in getting some unusual publicity for the firm's song, "Yoo Hoo." Previously "Mr. X," who is also connected with the Chicago Evening Post, through the assistance of Harry Singer, who is Chicago manager of the Orpheum Circuit, carried out a publicity stunt in favor of the same song, with the aid and assistance of a number of acts playing at the State Lake Theatre. A series of photographs and a large-size story on the unusual "stunt" appeared in both papers.

"STOP! REST AWHILE!"

Novel Publicity Being Used by L. Wolfe Gilbert Corp. to Feature This Number

From indications it would seem that "Stop! Rest Awhile!" described as a blues novelty fox-trot song, and published by the L. Wolfe Gilbert Music Corp., will be among the biggest successes of that type of number before many months. The professional and sales departments of this publishing house think so well of its value that they have made a special advertising appropriation in order to exploit it.

Some particularly novel and attractive material has been issued in order to give the number publicity. This includes the reproduction of a "traffic cop" with appropriate copy which most readily carries the message of "Stop! Rest Awhile!" This special idea is being used in many forms. Among these is a life-sized cut-out, in wood, which has been placed in the front of the publisher's offices.

From the present plans this particular "traffic cop" promises to become well known in the musical world.

SECURES NOTED ENGLISH BALLAD

Chappell-Harms, Inc., has secured the American rights of the successful English ballad, "There's Silver in Your Hair." The lyric of the number is by Warton David and the music is by Lawrence Wright and was originally published by the Lawrence Wright Music Co., of London. The American publishers will exploit the number in a large way.

A SOLID, SMASHING, SURE-FIRE HIT!

STOP! REST AWHILE
Blues Novelty Fox-Trot-Song

L. WOLFE GILBERT MUSIC CORP., 165 West 47th St., N. Y.



"Birds of a Feather"

There is an old and true saying that "Birds of a feather flock together." Have you ever applied this, Mr. Victor Dealer, to the Talking Machine Business? If not, you should do so. It can and should be applied profitably in business.

The Victor Talking Machine Company, with courage of forethought and persistency in practice, reached a standard commonly referred to as "Victor Supremacy." Victor Supremacy, however, could not have been accomplished without high-class wholesalers and retailers.

The World War has upset pre-war standards, broken up business organizations, disrupted policies, shaken loyalty and even created disloyalty. During the present reconstruction period, however, it is inevitable that "Birds of a feather flock together."

We believe that we represent to-day the best manufacturer of talking machines, and we are striving to be the best Victor distributor. Likewise, we seek the business and support of the best Victor dealers. The Victor Policy and Blackman Policy were established to stand the test of time and conserve "good-will."

We are refusing thousands of dollars' worth of business because it would not square with the "Blackman Policy." We have refused many accounts who wanted to become Victor dealers and who were later on established by others. The same applies to our refusal to do business with some Victor dealers already established.

It is not the Blackman Policy to take all the business we can get, and we do not say that our Policy is perfect or the only one that should be supported. We want to know frankly, Mr. Victor Dealer, what you think of the Blackman Policy. If you do not know it, let's get acquainted. If it is wrong, we want to change it—if right, we want the support of many more Victor dealers of the better type, for "Birds of a feather flock together."

There is going to be nothing reasonable left undone to take care of the requirements of Blackman-Victor dealers for the coming holiday season, but we will be obliged to give support in proportion to our obligations through support received.

Think it over, Mr. Victor Dealer, and let us hear from you.

J. NEWCOMB BLACKMAN.

Blackman
TALKING MACHINE Co.
28-30 W. 23RD ST. NEW YORK N.Y.
VICTOR WHOLESALE DISTRIBUTORS



NEW OKEH RECORD ARTISTS

Virginia Female Jubilee Singers Added to Okeh Library—Sing Negro Spirituals in True Spirit

The General Phonograph Corp. has just announced a series of Okeh records by a new combination of singers known as the Virginia Female Jubilee Singers. For months the company's representatives had been touring the South in



Virginia Female Jubilee Singers

search of artists who were capable of interpreting realistically the old-fashioned negro spirituals and they recently discovered this quartet of singers in the country regions of Virginia and engaged them for the Okeh library. These four young girls are so filled with the true religious spirit that they have an extensive knowledge of all the spirituals which have attained any degree of popularity, and which have been handed down in folk-song fashion from one generation to another. They sing without any accompaniment and their first Okeh records have been praised enthusiastically.

The company is releasing these records as standard numbers, and not as novelty selections.

A permanent demand for these Okeh spirituals is anticipated, and considerable care and attention were devoted to the recordings.

INAUGURATES SELLING CAMPAIGN

Jones-Motrola, Inc., Expands Line of Distributors and Representation for Well-known Motrola—Latest Product Wins Praise

Jones-Motrola, Inc., New York City, manufacturer of the "Motrola," an electric phonograph winding device, has put an extensive selling campaign behind the "New Motrola" with Universal motor. The sales organization of the company has been materially expanded within the last few months and a representative list of prominent distributors has been secured for this well-known device throughout the country. The price of the new Motrola, \$19.50, in comparison with the former price, has proved very popular, and at the present time the factory of the company is working at full capacity to take care of the large volume of orders being received. This considerable reduction in price has been made possible through the lower cost of production and the reduction in price of raw materials. Also the estimated increased volume of business at the lower price was taken into consideration.

The "New Motrola" has a universal motor operating on electric currents from 105 to 125 volts, and special types are produced for the 32-volt farm lighting currents and localities where 200 to 250 volts are used. All the distributors who have taken on the Jones-Motrola line are enthusiastic over the product and are featuring it in their respective territories in an energetic way.

TONE-MODIFYING DEVICE POPULAR

A. P. Frangipane, of the Mutual Phono Parts Co., New York City, reports that the new tone-modifying device, which was announced to the trade last month, has proved popular and that orders are being received in a satisfactory volume for this newest phonopart produced by the company.

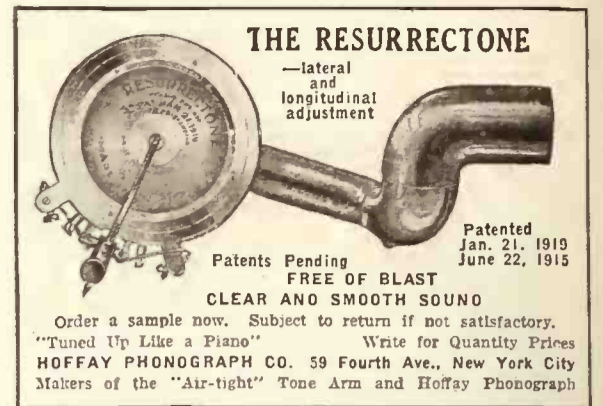

GRIFFIN'S RECORDS POPULAR

Gerald Griffin's Okeh Records Well Received—Artist Is Well Known Here and Abroad

The Okeh records recently made by Gerald Griffin, well known to the musical world as one of Ireland's sweetest tenors, have met with a cordial reception from Okeh dealers everywhere. Mr. Griffin is gifted with an exceptionally pure tenor voice, and the selections he sings for Okeh records are all of Irish character.



Gerald Griffin

Gerald Griffin is not only a singer of note but is also a producer of Irish plays with a large following here and abroad. He has visited, practically every country in the world, and his rollicking Irish wit has helped to cheer thousands of soldiers and sailors throughout the world. He is an active member of every prominent Irish organization in this country, and popular in the circles of the Knights of Columbus.

A fire which recently broke out in the plant of the Labella Phonograph Mfg. Co., at 387 South First street, Brooklyn, N. Y., was extinguished before much damage was done. The prompt arrival of the firemen prevented the company from suffering serious damage.

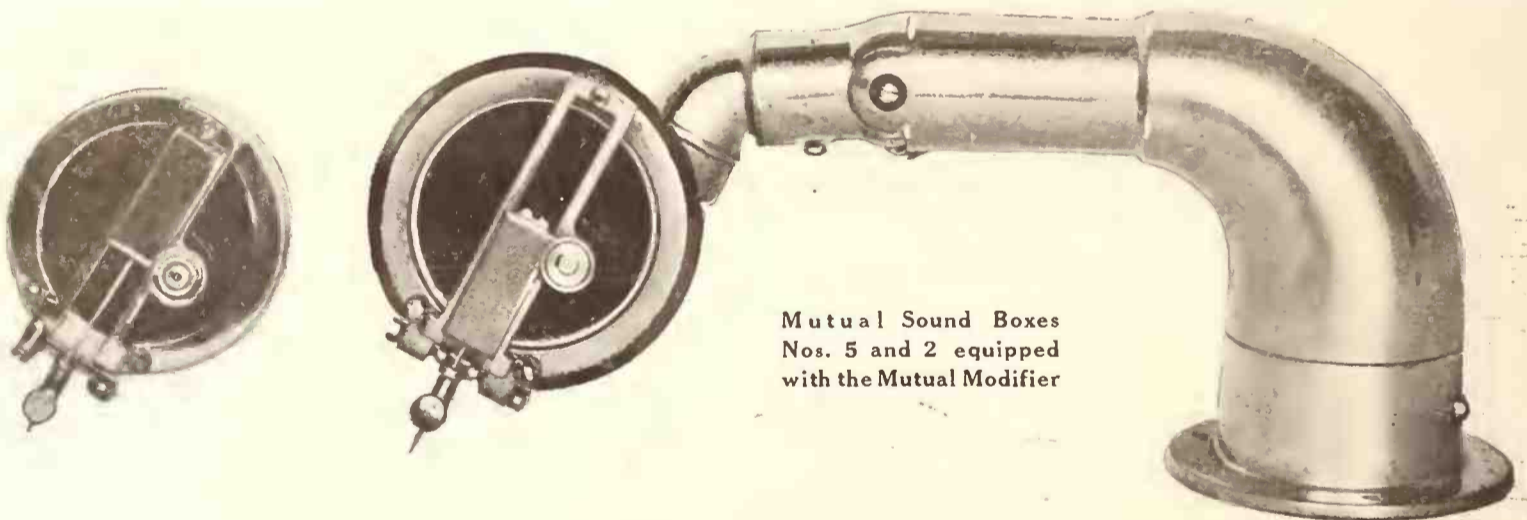

Mutual Sound Boxes
Nos. 5 and 2 equipped
with the Mutual Modifier

THE MUTUAL TONE MODIFIER

Does not muffle but decreases the sound, leaving all the original shading.

By the simple process of controlling this new device upon the sound-box will shade the tone produced to any desired degree.

It is simple and indestructible and its performance is accurately correct. It effects considerable saving in comparison with other forms of modifiers and is particularly appropriate for the portable machine. This modifier is adaptable to every known make of sound box.

Manufacturers, Jobbers, Dealers, write for our proposition TODAY

The Mutual Phono Parts Mfg. Co.

Manufacturers of Mutual Tone Arms and Reproducers

149-151 Lafayette Street

NEW YORK

EMANUEL BLOUT'S WINDOW DISPLAY OF VICTOR RELEASES

"Shuffle Along," the lively musical show, with a cast made up entirely of colored people, continues to draw capacity audiences at the Sixty-third Street Theatre, New York, from the fact

the Victor dance releases from "Shuffle Along," namely, "Bandanna Days," introducing "Wild About Harry," and "Baltimore Buzz," introducing "In Honeysuckle Time." The score of the

THE BRUNSWICK RECORD DIGEST

Attractive Little Booklet Issued Monthly for Distribution to the Public

For distribution among prospects and owners of Brunswick phonographs the Brunswick-Balke-Collender Co. is issuing a timely little monthly illustrated booklet containing general musical news of interest and value, together with pertinent comments regarding new Brunswick records, particularly the growing list of noted artists who are making them. The Record Digest is of medium size and is sufficiently interesting to make the recipient stop and read it.

NEW VICTOR STORE IN LAFAYETTE

LAFAYETTE, IND., November 7.—A deal has just been consummated between the Claypool & Miller Music Co., of this city, and the wholesale Victor division of Lyon & Healy, whereby the former company becomes an exclusive Victor representative. The Claypool & Miller Music Co., which is one of the oldest music establishments in Lafayette, for many years has been representing several well-known piano manufacturing houses.

BURNS & MORELAND OPEN STORE

CAMERON, Mo., November 4.—Burns & Moreland, well-known music dealers of Kansas City, have opened a fine music business on South Chestnut street, this city. A full line of pianos, musical instruments, supplies, talking machines and records is handled.

ESCAPED WITH SMALL FIRE DAMAGE

In attempting to extinguish a fire in the basement beneath the establishment of the Columbia Music Shop, Amsterdam, N. Y., the stock of talking machines and records was damaged by water to the extent of \$600.



How the Hits From "Shuffle Along" Were Presented in Blout's Window

that it is distinctly different from the average run of Broadway musical shows and is full of the sort of melodies that appeal.

The talking machine records of the various numbers in "Shuffle Along" have been in great demand and have been strongly featured by dealers. The accompanying illustration shows one of the show windows in the store of Emanuel Blout, Victor wholesaler and dealer on upper Broadway, New York. The window was decorated by H. Gold, and was devoted entirely to

piece is published by M. Witmark & Sons, the prominent New York publishers.

REGISTERED IN NEW YORK STATE

The Olympic Disc Record Corp., New York City, which is a Maryland corporation, was recently registered to do business in New York State. The designation gave 2,500 shares of preferred stock at \$100 each and 250 shares of common stock at no par value.

Order NOW for Xmas Trade

The Lundstrom Converto Cabinet is ideally adapted to conditions existing today. The fact that a person can have—by purchasing a small Victrola or Columbia and a Converto Cabinet—a reliable cabinet or console type machine AT A LOW PRICE will make sales possible for many dealers this Xmas that they would otherwise lose.



Converts a small Victrola into a beautiful Cabinet type all inclosed. Protects machine and records.

Lundstrom
CONVERTO
PATENTED DEC. 11, 1917
Talking Machine CABINET



Victrola is set into right hand compartment to play through door in front; winding handle is replaced through side.

Be sure you have enough stock. Push its sale this season and you attract trade that otherwise wouldn't come.

Run some local advertising for the combination and mention price, as many large stores are doing.

We'll send cuts and circulars free to any Converto dealer.

Order cabinets from your regular distributor.

THE C. J. LUNDSTROM MFG. CO.

LITTLE FALLS, N. Y.

Lundstrom "Converto" Cabinets are broadly covered by patents. Infringements will be promptly prosecuted.



A store whose equipment is cheerfully inviting! The Krause Furniture Co., Chicago, Ill.

Where Would You Buy?

With product and price the same, you would unquestionably select the attractive store—so would your customers.

Why not follow the profitable example set by leading dealers throughout the world and have attractive Unico Equipment increase your profits?

There is a definite trend upward in the talking machine industry. Now is the time to take full advantage of Unico Service.

A rush order today will still give you Unico Equipment in time for "peak" business.

Speed Does Not Interfere With Unico Quality.

Our factory has been steadily at work preparing equipment to meet the demand of business revival. You get the benefit of increased quality and lowered costs possible only through standardization of product and the unit principle.

CUSTOM BUILT EQUIPMENT and STANDARDIZED QUALITY—that is the unique accomplishment of the Unico System.

Mr. Krause is proud of his Unico Equipment—a glance at the illustration will show why. He says, "I want to thank you for giving me what I believe to be the finest Victor store in Chicago."

You, too, can have a distinctive Unico-equipped store. Complete departments, room, racks and counter from \$450.00 upwards. Terms if desired.



We'd like to demonstrate what Unico Equipment can do for your store. A rough floor plan with dimensions is all we need.

UNIT CONSTRUCTION COMPANY

NEW YORK
299 Madison Ave.
Corner 41st St.

Rayburn Clark Smith, President
58th Street and Grays Avenue
PHILADELPHIA

CHICAGO
30 N. Michigan
Boulevard

HAPPENINGS IN THE DOMINION OF CANADA

CANADIAN MANUFACTURERS HOLD MEETING IN TORONTO

Discuss Accommodation for Phonograph Exhibitors at Canadian National Exhibition—Other Subjects Discussed—Death of Samuel J. Cox, General Manager of the Brunswick Interests in Canada

TORONTO, ONT., November 8.—At a luncheon meeting of phonograph manufacturers held at the Ontario Club recently a committee was appointed to confer with the Canadian National Exhibition re accommodation for the phonograph exhibitors at the fair. A large number were present at this gathering, including Messrs. W. B. Puckett, president Canadian Phonograph Association, Musical Mds. Sales Co., Brunswick distributor; A. E. Landon, manager Columbia Graphophone Co.; S. J. Cook, McLagan Phonograph Corp.; I. Montagnes and Gordon Bender, of I. Montagnes & Co., Sonora and Magnavox representatives; R. H. Murray, Berliner Gramophone Co., Ltd.; F. A. Trestrail, Musical Merchandise Sales Co.; E. C. Scythes, Scythes-Vocalion Co., Ltd.; J. D. Ford and John Fullerton, acting secretary in the absence of Mr. Merrick. The chair was occupied by President W. B. Puckett, who asked the secretary to read the minutes of the last meeting of the Association. Before proceeding with the business of the meeting Mr. Trestrail referred to the finances of the Canadian Bureau for the Advancement of Music. The list of subscriptions he considered a reflection on the phonograph division of the music industries and that in comparison with the piano division it had not nearly done its part. He urged a more generous support of the valuable work of the Bureau. A discussion anent the projected "Music Temple" at the Canadian National Exhibition resulted in a resolution that the phonograph trade go on record as being favorable to its erection.

Harry Bolton, long connected with the Nordheimer Piano & Music Co., Ltd., Hamilton, Ont., as phonograph expert, has left that firm's employ to go into the auto export business in that city.

H. G. Stanton, vice-president and general manager of R. S. Williams & Sons Co., Ltd., Toronto, Edison jobbers, has been appointed to act as chairman of the Organization Committee, which will have charge of raising funds in the big Federation Community Service Drive now under way in this city.

The Nordheimer Piano & Music Co.'s store in Hamilton, Ont., recently took on "His Master's Voice" agency.

Samuel J. Cox, general manager of the Brunswick-Balke-Collender Co., of Canada, passed away recently at his residence in Toronto. He was in his sixty-seventh year and was born in Brownsville, Pa. He had been in the service of the company for the past thirty-five years, having been in Chicago, Buffalo, Syracuse, Albany and New York, before coming to Toronto fifteen years ago as manager of the company's Canadian business.

The late appearance of Eddie Johnson, the Canadian Victor artist, in his native town of Guelph, Ont., proved a big stimulus to the sale of his records.

J. Russell Croden, of the Starr Co. of Canada, London, Ont., was recently married to Miss Agnes Barron, daughter of Caven Barron, formerly head of the London Conservatory of Music.

INCREASING DEMAND FOR CARUSO RECORDS IN TORONTO

Dealers State It Is Difficult to Supply the Demand for Great Artist's Recordings—Layton Bros.' Attractive Windows—Scotti Grand Opera Co. Helps Sales of High-class Records—Other Items

MONTREAL, CAN., November 3.—All dealers in this city report increased sales of Caruso records. "The sadness of his taking off when still a young man, and his great popularity, turned people's thoughts to him," is the way one dealer accounted for the increase. "The impetus comes because people know that the records will be very valuable in years to come, and people should care for them," said another local dealer.

Many stationers are beginning to discover the profit possibilities inherent in a good stock of phonographs and records. Especially is this true where the dealer is situated in a residential district.

Previous to the appearance in this city of the Scotti Opera Co., Solomon's, "His Master's Voice" dealers in a recent advertisement drew attention to and recommended the purchase of certain selections from the various operas to be produced by this operatic company.

During McGill University Centenary week, Layton Bros. had one of their show windows appropriately decorated in University colors (red and white) together with trophies won by McGill. In the center of the same conspicuously arranged was an Edison machine. The window attracted considerable attention and the publicity gained was not lost on the Edison phonograph so prominently displayed. This concern, by the way, is advertising that it will pay the fare of all Eastern Townships customers to Montreal who purchase from them a new phonograph, either Edison, Brunswick or Columbia Grafonola.

The home of Gilbert Layton, of Layton Bros., was favored the past week by a visit from the stork, who left a miniature edition of the head of the house. "A sure enough phonograph man," agreed Gilbert on being introduced to his son,

but he thought the young man's voice sufficient in itself for some time to come without the necessity of undergoing re-creation.

H. Yates & Co., Cornwall, Ont., have added additional demonstration booths to take care of increased business in "His Master's Voice" products.

The parlor coach of a Canadian National Railway train has been equipped with a New Edison phonograph by R. S. Williams & Sons Co., Ltd., Toronto.

The Starr Co. of Canada, London, Ont., announces the reduction of the price of Starr (Genett) ten-inch records from \$1 to 65 cents retail.

During Music Week in Montreal various "His Master's Voice" dealers united in using a full page in the leading local English and French dailies featuring "His Master's Voice" records and machines.

The Columbia Graphophone Co. used large-sized copy in cities where the Scotti Opera Co. is appearing, announcing that "Stracciari and

Rothier, both members of this operatic organization, are exclusive Columbia artists." A full list of their recordings followed, together with the names of the various dealers handling Columbia records and machines.

Phinney's, Ltd., Halifax, N. S., is bringing to that city Edison tone-test recital artists, including Miss Leola Lucy, Adrien Freiche and Raymond Barry. It has always been the custom of this firm to issue invitations for these annual events, but this year they are doing away with this and are inviting the public through the press, all that is necessary being to apply at their store for tickets.

TRADE HAPPENINGS IN WINNIPEG

Talking Machine Dealers Active in Promoting Business Throughout Manitoba

WINNIPEG, MAN., November 4.—In Robinson's department store the showrooms have been placed near the dining room, and open partitions between the two departments allow diners to hear all the latest music as they dine. The management reports a large increase in sales since Mr. Moore has taken charge.

Alex Sanderson, for the past three years Edison record salesman at the Winnipeg Piano Co., has resigned to take up his permanent residence in Los Angeles. Before leaving, the staff of the Winnipeg Piano Co. gave him a farewell party and presented him with a beautiful tie pin.

M. Frankland, manager of the phonograph department of the Winnipeg Piano Co., is back at work after an illness that confined him to the house for some time.

The recent death of the great Victor artist Caruso has augmented the demand for his records very considerably. Edward Johnson, the Canadian tenor, also a Victor artist, is likewise a great favorite with buyers. Florence Macbeth, Clara Butt, Kathleen Parlow and Percy Grainger are all booked for Winnipeg this Fall and Winter and should swell the record receipts of the local dealers.

The talking machine department of James Ramsey's department store has been enlarged. Mrs. Vance is in charge and is satisfied that the added demonstrating rooms will insure an increased volume of record sales.

The Edison dealers and salesmen of the Province of Manitoba recently held a conference in the Royal Alexander Hotel, this city. Mr. Wagner, of Toronto, James Arthur, George Paul and Mr. Burns, of Winnipeg, gave a series of talks on selling and general points for increasing business.

The past week, at the Third Avenue Methodist Church, in Saskatoon, Sask., before a large audience, the New Edison scored a convincing triumph. Helen Newitt, soprano, sang in direct comparison with the re-creation of her voice. Virginia Powell made the same test of comparison with the re-creations of her readings and as a result Collard & Collard, local representatives, stated that this re-creation recital will result in many sales during the next few weeks.

TALKING MACHINE SUPPLIES AND REPAIR PARTS

The superiority of RENÉ MADE SPRINGS and PARTS is not accidental but is the result of years of painstaking devotion to the highest standards of machine shop craft.

NONE BETTER IN QUALITY

NONE LOWER IN PRICE

THE RENÉ MANUFACTURING CO.

Montvale, New Jersey

See page 66

THE STEPHENSON MOVEMENT

Sturdiness

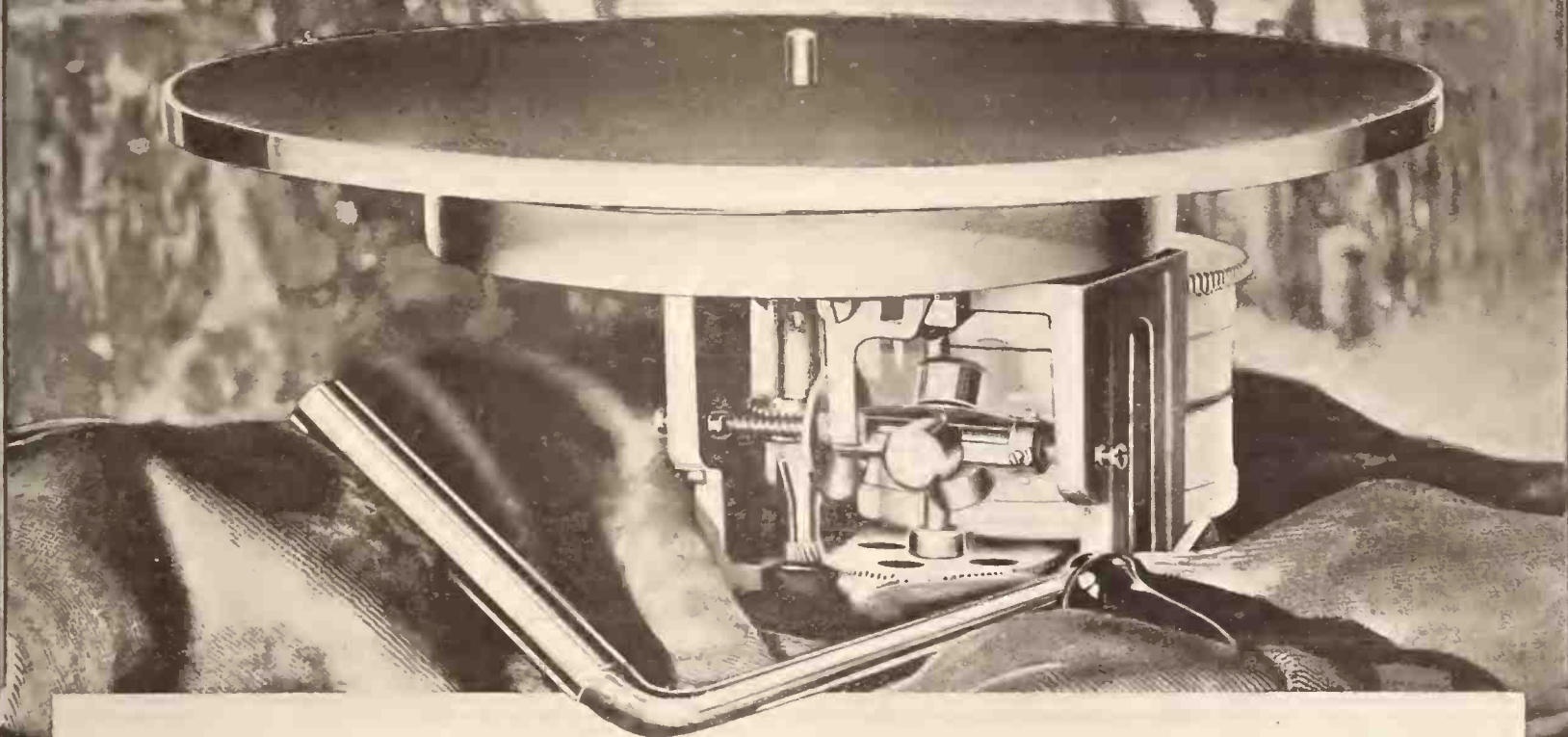

In the design of a phonograph motor, there must be strength where strength is necessary; and a proper co-ordination of all moving parts. For unnecessary strength makes awkward design, and lack of co-ordination, unnecessary wear.

¶ The one piece casting of the Stephenson Movement* is rugged and strong

and of compact design; and the moving parts—the interchangeable spring-drums, the triple thread worm, the turn-table shaft and the intermediate gears—are designed with proper relation

one to another and to their proper place in the casting.

¶ The Stephenson Movement* is sturdy and Precision-Made.

STEPHENSON

DIVISION
DE CAMP & SLOAN INC.

One Hundred and Seventy Pennington Street
Newark, New Jersey



*Trade Mark

CHANGES IN CARDINAL EXECUTIVES

F. F. Dawson, General Sales Manager; I. F. Manning in Charge in New York, With R. E. Kubie, Office Manager; Robt. Clifford Manager of Recording and Production

Following a visit of George Hayden, Jr., general manager, secretary and treasurer of the Cardinal Phonograph Co., of Newark and Zanesville, O., to the New York offices of the company, a reorganization of the policies in several of the executive offices of the company was announced.

F. F. Dawson has been appointed general sales manager of the company and the sales offices have been moved to Cincinnati, O., under his jurisdiction.

Ira F. Manning, vice-president of the company, has been placed in charge of the New York offices and Robert E. Kubie has been made office manager of these same offices.

Robert Clifford has been appointed manager of recording and production. The record department of the Cardinal Phonograph Co., although only one year old, has had rapid growth. It was recently announced that the Cardinal Phonograph Co. had made new recording and pressing arrangements which are now visualized in the quality of the Cardinal record. Mr. Clifford has given much of his attention to this particular phase of the work and even larger growth is expected as he devotes his entire time to the recording and production of records. It is his plan to build up a catalog of wide variety and each succeeding month will contain a list of releases that will show material progress toward this end.

Two new distributing agencies have been appointed. In Cleveland, O., the Tiffany Phonograph Sales Co. will distribute Cardinal records in northern Ohio, and the Sterling Roll & Record Co. in Cincinnati will distribute Cardinal machines in that same State.

George Hayden, Jr., general manager of the company, reports that the new line of Cardinal machines is now ready for delivery. The new line includes many improvements and refinements and the samples which have been shown within the last few months have developed many orders from dealers.

STEADMAN OPENS BRANCH STORE

The Steadman Music House, Warburton avenue, Yonkers, N. Y., has opened a branch store in the southern section of that city, at 440 South Broadway, for the convenience of purchasers in that section of the city. The new establishment will carry a complete stock of Edison phonographs and Re-creations.

INCORPORATED

A charter of incorporation was recently granted to the Recording Mechanism Corp., under the laws of the State of Delaware, with a capital of \$300,000.



THE QUAKER MAIN SPRING

Deserves a Fitting Cover

You'll say so the moment you lay your eyes on this clean-cut, well-finished spring.

Of carbon steel specially heat treated, highly tempered and with a glass hardened surface, the Quaker is really different from other springs.

A Convenient Package

numbered so you can pick out the desired size in a jiffy, saves you time and temper. And it protects this extra fine spring from dust and rust.

Write for it

The Quaker Main Spring Chart is the most complete chart ever compiled.

EVERYBODY'S

Talking Machine Company

38 N. 8th Street

Philadelphia

JOBBER: WRITE FOR OUR EXCLUSIVE PROPOSITION

OKEH FAIR EXHIBIT A SUCCESS

Progressive Okeh Dealer Maintains Attractive Exhibit at Suffolk County Fair—Closes Profitable Record and Machine Business

At the Suffolk County Fair held recently at Riverhead, L. I., Okeh records were exhibited by Sylvester L. Cavanaro, a progressive Okeh



Cavanaro's Exhibit at Suffolk County Fair dealer of Riverhead. The exhibit was a signal success, as the average daily attendance at the fair was in the neighborhood of 15,000 people.

Mr. Cavanaro states that the Okeh exhibit attracted considerable attention and that his booth was visited by more than 15,000. They listened

to Okeh records attentively, examined the various phonograph lines handled by Mr. Cavanaro and took away books, catalogs, circulars, etc. Out of this number of visitors this live-wire dealer secured some excellent prospects which were immediately followed up by canvassers. Mr. Cavanaro has a canvassing truck and as a result of his energy twelve phonographs, with good-sized libraries of Okeh records, were sold to visitors to the fair before the exhibit closed.

It has been generally believed by retailers that an exhibit at a county fair should be charged off to publicity, with no possible chance of making expenses. Mr. Cavanaro, however, not only made up all his expenses incidental to the exhibit, but showed a handsome profit, and in addition secured a great many new prospects for Okeh records and phonographs that he handles.

VISITORS AT PEARSALL OFFICES

Among the recent visitors at the offices of the Silas E. Pearsall Co., 10 East Thirtieth street, New York, Victor wholesaler, were Wm. F. Larkin, manager of the music department of Forbes & Wallace, Springfield, Mass., and Max Lichtner, of the Loomis Temple of Music, New Haven, Conn. Both of these visitors were optimistic and predicted a healthy and active holiday trade.

The Fenton Mfg. Co., of Detroit, Mich., has been granted a charter of incorporation, under the laws of that State, with a capital of \$10,000.

Are You Sure You're Getting All the Business Possible in Your Neighborhood?

If You Don't Sell

Okeh Records
You Are Not

EVERHART & BROWN

::

1705 E. Broad St., Richmond, Va.

CINCINNATI DEALERS WAGE CAMPAIGNS THAT EDUCATE

Public Realizes That Talking Machine Is a Necessity—Trade Growing in Volume—F. F. Dawson Plans Cardinal Sales Campaign—Sales Force Being Educated—Chubb-Steinberg Publicity Stunt

CINCINNATI, O., November 9.—Recent campaigns waged in the city by the music shops have not only been effective but they have instilled in the minds of the public that the talking machine is as much a necessity to each and every home as a stove or table. In anticipation of a record holiday trade, the various shops throughout the city are beginning to stock up to their utmost capacity. Spirits of the dealers have risen sky-high with the closing of a very satisfactory month and the promising outlook of a banner holiday trade.

Dealers have watched with much satisfaction the increasing return of the office trade, commonly called the "white collar" brigade. This trade, which includes bank clerks, office help and moderate salaried men, is, during normal times, considered the very backbone of the purchasing public. Due to the comparatively small increase in their salaries as compared with the high prices of the past few years they have been unable to purchase anything but necessities. The gap was readily filled by the laborer and mechanic for a time, but since the laborers have been unemployed and have ceased to have money the absence of the office trade has been felt more keenly. Their return to the trade is an assurance that normal times are in sight, according

to men in the music world, and has had an immediate effect, for they are the cash customers.

F. F. Dawson in Charge

F. F. Dawson, general sales manager of the Cardinal Phonograph Co., is planning an extensive sales campaign which he is rapidly whipping into shape. Mr. Dawson, who is president of the Sterling Roll & Record Co., recently assumed the responsibilities of his new venture. George Schultz, formerly with the Columbia Co. at Indianapolis, has been placed in charge of the Pittsburgh office of the Sterling Co. Fred Reid, of the Pittsburgh office, is now city sales manager. A new addition to the local Sterling office is Miss Virginia Kirkpatrick, who has been made secretary to Mr. Dawson.

School for Sales Force

E. M. Abbott, proprietor of three stores in Cincinnati, opened a school under his personal direction for his sales force. Each morning before they begin their regular work they assemble in the office of Mr. Abbott and talk over the prospective sales for the day. Ideas are exchanged and experiences are related. Suggestions are offered and each man outlines his plans for the day. The meeting covers one hour and closes with a talk on "pep" by Mr. Abbott. As a result each salesman starts the day fresh. In the evening the men are again assembled and they discuss their success and failures. In this way each salesman gets the benefit of the other's mistakes. The results have been astonishing, according to Mr. Abbott. He has ten outside men and expects to take on five more shortly. "Business is plentiful, but it is twice as hard to get as it was a few years ago," he says. "Our men are following an entirely new course. We try to educate people to the necessity of music first and then we take a chance on giving them the best proposition." Mr. Abbott added the Brunswick line to his stock last month.

Iowa Columbia Sales Force

Widener's Columbia Shop has added Harry Folger and Henry Brookbank to its sales force. Business for the past month has been good, reports Morris Fantle, manager. Robert C. Clark, who handles the Granby line, continues to meet with success.

The Alms & Doepke Co. has adopted a catchy slogan in connection with its phonograph department, which reads: "Give a dance at our expense. If you are planning a dance we will loan you a Pathé phonograph and the assortment of records entirely without charge or obligation. When the dance is over we call for the phonograph and the records." The company is now the sole distributor in the State of Ohio for Pathé and Actuelle lines.

Bubble Book Party

The "Bubble Book Party," being arranged by F. X. Donovan, manager of the Victrola department of the John Shillito Co. for November 23, promises to be a great success. The party is to be staged in the large music department of the store and an especially arranged children's playlet is to be staged with a number of story-book characters, all played to the strains of appropriate music from children's records. Business for the past month has been fair, reports Mr. Donovan, with the prospects getting brighter each week.

Great Publicity Stunt

The Chubb-Steinberg Music Shop put over one of the neatest publicity stunts of the season during the recent Health Exposition at Music Hall, during which it carried on a competition, the winner of which was given a talking machine. On the last night of the performance it arranged with the directors of the show to hold a drawing for the machine on the stage in Music Hall. Therefore, following the regular show and entertainment and before the audience, which numbered over 5,000 persons, had time to leave the auditorium, Chubb-Steinberg workers with a

(Continued on page 150)

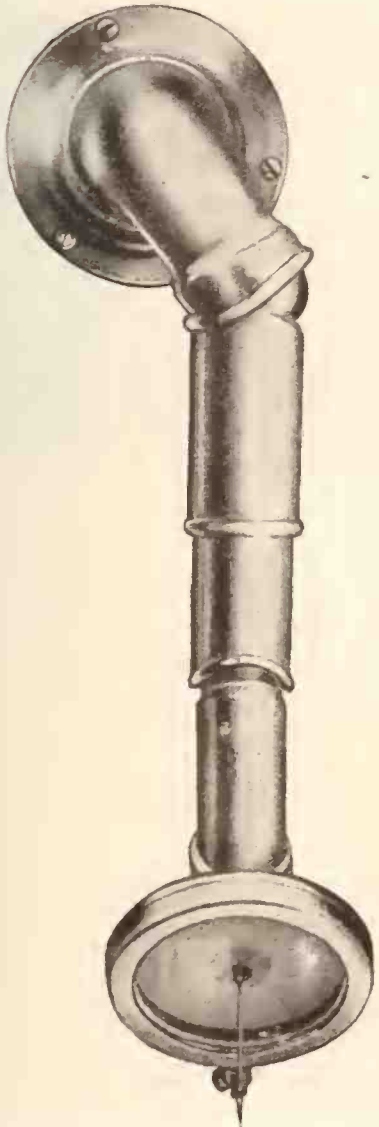

**A New Oro-Tone Product
3-D Arm. O-3 Reproducer**

The arm is adjustable in length from 7½ to 9 inches.

Made to meet the demand for a dependable Arm and Reproducer at a low price.

SEND FOR SAMPLE

THE ORO-TONE CO.

1000 to 1010 George St. Chicago, Ill.

PLAZA

BUY YOUR ACCESSORIES
"All From One Source"

PLAZA MUSIC CO. TRADE MARK

REPAIR PARTS
NEEDLES
CLEANERS
ENVELOPES
SAPPHIRES
ALBUMS
RECORDS

**SPECIAL ON
CLOTH-BOUND
RECORD ALBUMS**

<u>6 doz. orders</u>	Less	
10-inch	50c	55c
12-inch	60c	65c

HEADQUARTERS FOR

- RECORD DELIVERY ENVELOPES
- ALBUM SETS FOR No. 80 VICTROLA
- ALBUM SETS, ALPHABETICALLY STAMPED
- REPAIR PARTS
- KENT ADAPTERS
- NOVELTY TOY RECORDS
- MIRRORLIKE POLISH
- CONVERTO CABINETS
- BRIGHTONE STEEL NEEDLES
- MAGNEDO MULTI-PLAYING NEEDLES
- SUPERTONE STEEL NEEDLES
- SHEET MUSIC
- RECORDS
- MUSIC ROLLS
- RECORD CLEANERS
- PHONOGRAPH DELIVERY COVERS
- BUBBLE BOOKS
- FIBRE NEEDLES
- FIBRE NEEDLE CUTTERS
- RECORD FLASHERS
- REPEATOGRAPH
- TONOPHONE NEEDLES
- REFLEXO NEEDLES
- DANCING "SHIMANDY"
- DANCING RASTUS
- PLAYER-PIANO VACUUM CLEANER
- SUPPLEMENT MAILING ENVELOPES
- SAPPHIRE BALL NEEDLES
- SAPPHIRE POINT NEEDLES
- DIAMOND POINT NEEDLES
- UNIVERSAL DISPLAY RACKS
- SHEET MUSIC RACKS
- NYOIL
- BOBOLINK RECORDS AND PHONOGRAPHS
- PHONO MOVIES
- STOCK ENVELOPES
- "NULIFE" MUSIC ROLL ATTACHMENT
- SPRING LUBRICANT
- VICTOR AND COLUMBIA ATTACHMENTS
- TONE-ARMS AND SOUND-BOXES
- STEEL NEEDLES IN ENVELOPES WITH SPECIAL IMPRINT

Watch for our next month's specials

PLAZA MUSIC CO.
18 WEST 20TH STREET
NEW YORK



When Francis Dances With Me

"YOU CAN'T GO WRONG WITH ANY FEIST SONG"

ASK TO HEAR IT! INSTANTLY POPULAR IN VAUDEVILLE and for DANCING

GOOD WORK OF CINCINNATI DEALERS

(Continued from page 149)

flourish of trumpets and headed by a man carrying a large Victor dog paraded down the center aisle and marched up on the stage, where was spread a streamer announcing what the Chubb-Steinberg people planned. Other firms with booths at the exposition who had given thousands of dollars' worth of goods looked on and gasped, but it was too late to follow suit, for it was the last night and the show was over. Mr. Chubb stated that 23,000 coupons were given out during the contest. Business could not be better, he says.

Columbia Gives Music Course

A five-day course in "Music Appreciation" and "Measures of Musical Talent" was recently conducted by Nell I. Sharpe, educational representative of the Columbia Graphophone Co., in the Cincinnati Conservatory of Music. The course was intended primarily for public school teachers, but dealers, salesmen and representatives of the local Columbia branch attended most of the sessions. The course is expected to be of value in promoting the sale of Grafonolas.

Gives Credit to the Talking Machine

Nothing else but the talking machine is accountable for the rapid growth of appreciation of good music in this country, according to Mme. Doree, directress of her miniature opera troupe at Keith's.

"The advent of the phonograph placed in thousands of American homes records by good

singers. This has developed and advanced America's musical taste by leaps and bounds," she says. "A few years back it would have been folly to attempt to present in vaudeville an operatic act. To-day opera in vaudeville not only is appreciated but is genuinely liked. In short, Americans have discovered that there is nothing in opera to terrify them and that opera is good music and enjoyable."

Oelman Pleased With Outlook

P. H. Oelman, manager of the New Edison Co., reports a good month. The settlement of the railroad strike opened up the West Virginia and Columbus territory which had been quiet for some time, he said. Joe McKee, Charleston, W. Va., is leading in the sweepstakes contest being carried on by the Edison Co. among its salesmen. Other contestants are close on his heels, says Mr. Oelman. The contest has worked wonders among the force. Winners in the contest are to be given special courses in schools to be opened in the future by the Edison laboratories.

DUPIES TO OPEN NEW STORE

FOND DU LAC, WIS., November 1.—Roy Dupies, well known in local business circles, is planning to open a music store in the Koepnick Building on Harrison street, this city. The store, which is being remodeled to house the new business, will soon be opened to the public with a complete line of pianos, musical instruments, accessories, Victrolas and records.

NEW EDISON CHRISTMAS WINDOW

Display Arranged for Use of Edison Dealers Most Elaborate in Every Particular

The window display set going out this Christmas to Edison dealers is the most elaborate display ever issued by the Dealer Service department of Thomas A. Edison, Inc.

The display illustrates a charming home scene on Christmas morn with the kiddies dancing for joy at the Christmas gift of a New Edison deliv-



Attractively Arranged Edison Window
ered by Santa Claus, seen looking in at the window. The display consists of seven units, the centerpiece of which is an elaborate two-plane display, all done in the ten-color photo lithographic process, and makes a blaze of refined color such as is seldom seen in a talking machine shop window. The display is being shipped to Edison dealers in ample time for advance holiday showing.

MUSIC STORE REMODELED

Sterling Music House Much Improved by Alterations—Carries Complete Line of Talkers

PATERSON, N. J., November 7.—The Sterling Music House, 133 Ellison street, this city, has completely remodeled its establishment, greatly enhancing its attractiveness and adding many comforts and conveniences for patrons. The store, which is operated by Thomas J. Corkrey, now contains five demonstration booths and in addition to a complete line of James & Holmstrom, Jacob Bros. and other well-known makes of pianos, music rolls, sheet music, talking machines and records are handled.

NEW POST FOR RICHARD H. LEE

Richard H. Lee, for five years the outstanding figure in the truth-in-advertising movement of the Associated Advertising Clubs of the World, will, on December 1, become chairman of the National Vigilance Committee of the Association, retiring from the active direction of the movement to become vice-president of the Lord & Thomas advertising agency. In his new connection with the truth movement he will, of course, continue to supervise the activities of the committee.

The SHELTON MOTOR ELECTRIFIES

Victor, Edison or Columbia in one minute

There are 20,000 Satisfied Owners of
Shelton Motors in the United States

Write for Descriptive Literature and Dealer's Prices

The Shelton Sales Company

EDW. C. BOYKIN, General Manager
Eastern Distributors

299 Madison Avenue

New York City

See Advertisement on page 78.

COOLER WEATHER BOOSTS SALES IN DETROIT TERRITORY

Trade Helped by Concerted Advertising Campaign Looking to Christmas Orders—Music Week Benefits Evident—Jewett Prosperity—Dupraw Music Store in New Quarters—Other Removals, Etc.

DETROIT, MICH., November 9.—The combination of outside solicitations, from door to door, and a concerted advertising campaign, with more display space and novelties than ever before, are being used by Detroit talking machine and record dealers as the two chief means of getting business during the Fall months.

The coming of cooler weather has materially boosted sales in both talking machines and records, but it is a case of hustle at all times, and no dealer can afford to sit down and wait for the trade to come in. In practically every instance salesmen are being organized to call personally at each house in certain districts to solicit business and demonstrate machines and records. A good many of the dealers find that this has been an excellent method, in the face of the backward times, to keep business somewhere near normal for them. Special Christmas campaigns are already being talked of by most of the dealers and efforts are being made in every direction to have the year 1921 go down as a real "talking machine and record Christmas."

Columbia Dealers Reduce Stocks

Big Columbia advertisements announcing reduced prices have stimulated sales in great shape, according to reports. Most Columbia dealers report that in the last few months they have materially reduced their stocks in both machines and records. The dealers are very hopeful of a good Fall and holiday trade and, like other dealers in these wares, are preparing to go out and hustle for this business by personal solicitations.

Goldberg Opens Branch

The opening of a new branch talking machine agency at 2813 Hastings street is announced by the Goldberg Phonograph Store, 331 Gratiot avenue. It will carry a full line of Victrolas and Victor records. In the Hastings street branch it is planned to carry a full line of Jewish records that are familiar and dear to all lovers of Jewish music. A full line of Cantor Rosenblatt's records has been added.

New Victor Agents

There are several new Victor dealers in Detroit, the first time in more than five years that a new Victor agency has been granted in the automobile city. Among the new agencies for Victor machines and records are the Noble Piano Co. and the Sidney J. Guest Music Co.

Music Week Echoes

Music Week echoes are still being heard in and about Detroit and wherever dealers gather nowadays the success of the week and the prospects for another one soon seem to be the main topics of discussion. There is no question in the minds of everyone connected with the industry in this section that the week will eventually prove to be the greatest thing of its kind ever attempted.

"It may take months and it may take years and years," said one dealer in discussing the benefits of the week, "but the benefits of Music Week are assured. We may not be able to put our fingers on just how much business it will bring into the stores, but for the general good of everyone concerned nothing better could have been attempted. It will act as a general stimulant, with no one line of musical equipment getting a better share of the new business than the next.

High-class Records Favored

Detroit dealers say they are enjoying an excellent sale of high-class records by famous artists, which is an indication, they say, of the people taking a greater interest in the higher class of music. Detroit is experiencing the finest season of recitals in the history of the city, with many of the most noted artists in the country scheduled for recitals. Farrar and Galli-Curci, who have already been here, have played to capacity audiences and their records are in great demand at practically every store.

Detroit Piano Co. to Remove

The Detroit Piano Co., in seeking better quar-

ters, will move from its present location to one block further north on Woodward avenue. The move will be made on November 15. The new quarters will furnish better facilities for display and sales.

New Quarters for Dupraw Music Store

The Dupraw Music Store, 1448 Broadway, will move November 15 to 1510 Broadway, where new quarters have been provided which will add to room and display purposes. Rou Dupraw is planning to go after business in special campaigns from the new store. The Dupraws handle the Manaphone, manufactured by Clough and Warren at Adrian, Mich. Rou Dupraw has been connected with the piano and talking machine business for fifteen years.

Prosperous Times With Jewett Phonograph Co.

A. A. Fair, sales manager of the Jewett Phonograph Co., reports the addition of many new dealers throughout the United States from day

to day. The factory at the present time is over-sold on product, but increasing facilities for more production are expected to take care of the orders within a few months. Mr. Fair and the entire organization are delighted with the reception accorded the Jewett all over the United States and the number of reorders that have been coming in from the dealers. It is quite evident from the demand that the Jewett will be a big favorite during the holidays.

GENNETT RECORD PRICES REDUCED

A reduction in the price of Gennett records, manufactured by the Starr Piano Co., has been announced by R. C. Mayer, manager of the recording laboratories of that concern on East Thirty-seventh street, New York City. Popular and dance records which formerly were priced at 85 cents have been reduced to 75 cents; standard selections have been reduced from \$1.00 to 90 cents, and recordings of classics have been reduced from \$1.25 to \$1.15.

Mere lung power is not selling ability.

Don't Let the Christmas Demand For Victrolas and Records Find You Unprepared

—No reason why it should. You've but to avail yourself of our stock; our service; our transportation facilities NOW—and you will be ready to profit to the utmost through the big Christmas business we can absolutely depend upon this year. It is already commencing.

Ample stock of Victrolas and Records, at this season particularly, will go far toward greatly increasing your year's business. Be prepared!

We make it a rule to fill all orders same day received.

Write for list of records selected by our committee as the best sellers for the coming month. To allow us to furnish this will not obligate you in the least—and it will aid you in making up your order.

Grinnell Bros.

Wholesale Distributors
of Victrolas and Records

First and State Streets, Detroit

JAS. A. HEARN TO HANDLE TALKERS

Van Veen & Co., Inc., Equip Handsome Talking Machine Department in That Establishment—Some Other Concerns Recently Furnished

Jas. A. Hearn & Son, Inc., large New York department store, will shortly open a new and entirely complete talking machine department situated in the new building now being constructed as an addition to the large group now being used. It is predicted that the new department will contain the newest developments in equipment and will consist of nine hearing rooms, a sheet music and a record department. The department is being designed and constructed by Van Veen & Co., Inc., of New York City.

This same company also installed the equipment in the handsome new headquarters of Ormes, Inc., Victor wholesaler of New York City.

Considerable work outside of the metropolis has also been contracted for and completed. In

Philadelphia a complete interior with rooms was installed in the headquarters of Starr & Moss. Arthur L. Van Veen, president of the company, received a highly commendatory letter from Starr & Moss regarding the work. Another letter of which Mr. Van Veen is very proud was received from Frank Steadman, prominent talking machine dealer of Yonkers, N. Y., who stated in glowing terms that the installation was finished to his entire satisfaction.

NEW PORTABLE IS POPULAR

Outing Portable Meeting With Success—Cabinet and Accessories Co. Appointed Jobbers

The Outing Talking Machine Co., Mt. Kisco, N. Y., manufacturer of the Outing portable talking machine, is meeting with considerable success in the introduction of this new portable. This machine is now being handled by a large number of dealers in different sections, and the Cabinet & Accessories Co., New York, were recently appointed Outing jobbers.

The Outing portable has a number of distinctive features which have met with the hearty approval of the trade, and among these features are a twelve-pocket album, a twelve-inch turntable, a Universal tone arm and a double-spring motor. The company is endeavoring to cooperate with its dealers in every possible way, and the Cabinet & Accessories Co. report an active demand for this instrument.

NEU IN CHARGE OF EMERSON SALES

Manager of Emerson City Department Now in Charge of General Sales—Well Qualified for New Post, Which Is an Important One

Harry G. Neu, who some time ago was appointed manager of the city department of the Emerson Phonograph Co., New York, has also been placed in charge of the company's general sales, taking over the work formerly handled by Harvey Morrison. Mr. Neu, who is well known in the wholesale trade, is formulating important plans which will undoubtedly interest Emerson jobbers and dealers.

In a chat with The World, Mr. Neu stated that Emerson jobbers generally were most optimistic in their comments regarding business conditions. The new Emerson lists are meeting with a hearty reception from the dealers, and every possible form of co-operation is being utilized to advantage.

FOUR SPECIAL BRUNSWICK RECORDS

Eight Popular Dance Hits Included in Special Brunswick Releases for November

The Brunswick-Balke-Collender Co. has just announced four interesting special releases of dance records for November made up of the recognized hits of the day. The first record is of "Yoo-Hoo" and "Second Hand Rose," both fox-trots played by Carl Fenton's Orchestra. Then comes "Ilo" and "Sweet Man o' Mine," also fox-trots, by the Windsor Orchestra; "Say It With Music" and "South Sea Isles," by Wiedoeft's Californians, and "Sweet Lady" and "Bimini Bay," by Carl Fenton's Orchestra. It is stated that the announcement of the special releases has been received with enthusiasm by Brunswick dealers.

AN AGGRESSIVE MANAGERESS

Miss Ethel Walthour Largely Responsible for Up-to-date Establishment of Drake & Moninger Co. in Alliance, O.

ALLIANCE, O., November 7.—The aggressiveness and initiative of Miss Ethel Walthour, head of the talking machine department of the store of Drake & Moninger Co., is responsible for this concern having the best operated and equipped talking machine section in the city of Alliance.

Since the company moved into its new store in East Main street this department has been given much consideration and now occupies a large space to the rear of the main floor. The record files are handy and within easy access of the salesmen. She has a system for the record rack which makes it possible to find numbers without any delay. The store is now an exclusive Victor shop.

It is also announced that the Weaver line of pianos has been added and this department will be maintained to a high standard. Another new acquisition to the big store is the Q R S line of player rolls, which was added two weeks ago.

Miss Walthour for the past two weeks has been in charge of the company's new Victor store which was opened recently in Sebring, O.

NEW MUSIC STORE FOR ALTON, ILL.

ALTON, ILL., November 4.—An attractive new music store was formally opened on East Broadway, this city, recently by Berg W. Plummer. Musical instruments and accessories of all kinds are handled. Mr. Plummer intends to make a specialty of repair work of all kinds.

"Be Sure Your Walnut is ALL Walnut."



MODERN AMERICAN WALNUT
PHONOGRAPH CABINET.
CHIPPENDALE DESIGN.

**AMERICAN
WALNUT**
"The Cabinet-wood Superlative."

Walnut "Selling Talk."

NATURAL COLOR which requires no superficial stains.

Will not warp, shrink, nor swell and resists shock.

Can be carved with ease—with the delicacy of ivory. Can be worked to 1/1000 of an inch.

Strong. Substantial. The first choice of the skilled cabinet-maker.

Deep rich tones which harmonize with all color schemes.

Finishes beautifully with high polish varnish, wax or oil.

The world's greatest Cabinet-wood throughout history.

Manufacturers and alert retailers will think of plenty more good talking points about American Walnut. The public is learning fast. And we are telling them:

"BE SURE YOUR WALNUT IS ALL WALNUT."

Valuable data for manufacturers. Valuable data for dealers. ALSO the Walnut "brochure de luxe." Write to the responsible producers of American Walnut Lumber and Veneers, the

AMERICAN WALNUT MANUFACTURERS' ASSOCIATION
Room 1022, 616 South Michigan Boulevard Chicago, U. S. A.

One Dealer's Sales of Walter Camp's Health Building Records—in Only 6 Days!

Reports from all over the country indicate the enormous popularity of Walter Camp's famous daily dozen exercises for keeping fit, set to music on phonograph records. One of New York's leading dealers ordered 100 sets and 1,000 miniature sample records on October 22nd. Just six days later we received the following letter which speaks for itself as regards his quick turnover:

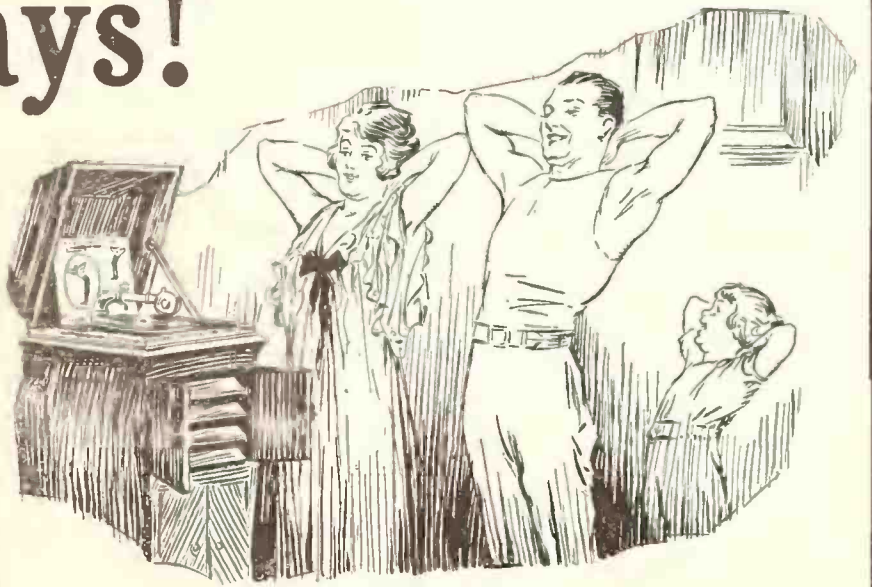

DAVEGA
The Sportman's Paradise
New York

EXECUTIVE OFFICES
831 BROADWAY
TELEPHONE
STUYVESANT 7300

FOUR SPORT SHOPS
15 CORTLAND STREET
531 BROADWAY
125 WEST 125th STREET
COMMODORE HOTEL

October 29, 1921

Health Builders,
334 Fifth Avenue
New York City.

Atten. Mr. Robert B. Wheelan

Gentlemen:-

Confirming 'phone conversation, please rush to us immediately one hundred additional complete Health Builder sets of Walter Camp's "Daily Dozen" exercises, and also one thousand additional twenty five cents sample outfits, on same terms as original order.

Also please loan us one of the cuts you have used in your national advertising, as we wish to use it for a newspaper "ad".

Yours truly,
S.B. Davega Co.
By *Harry S. Davega*
Treasurer

EL/HSDavega

own vivid style. Every command is given in a clear voice and is absolutely true to time. The exercises used have all been developed by Mr. Camp during his long, successful career with Yale University and were adopted by the United States Army and Navy during the war.

Quick Profits Assured—Exclusive Territory

You can make big and easy profits, as others are doing, through this new "Health Builder" system and the big boost it is being given by nation-wide advertising. One of our ads brought over 2,500 inquiries and \$5,000 direct sales in New York City alone. Mail the coupon today for sample 10-inch record with literature describing the profitable connection offered as "Health Builder" dealer for your locality. We will co-operate with you to the limit in building business by giving you the full benefit of strong sales propaganda.

Sample Outfit on Request

Cash In On This Popular Movement

Walter Camp's famous Daily Dozen Exercises, set to music on phonograph records, are making sensational sales everywhere. National advertising has created a phenomenal demand in all sections for these "Health Builder" records which keep one fit to music. Each set contains five 10-inch double disc records, 12 charts containing 60 real photographs, and a booklet of instructions written in Mr. Camp's

HEALTH BUILDERS

Dept. F.
334 Fifth Ave., New York

Please send me, prepaid, one 10-inch double-disc "Health Builder" record, carrying four of Walter Camp's "Daily Dozen," with four charts—and your special proposition to dealers. I have privilege of returning this outfit.

Name

Address

Featuring the MUSICAL POSSIBILITIES of the TALKING MACHINE

[EDITOR'S NOTE:—This is the thirteenth of a new series of articles by William Braid White, devoted to the various interesting opportunities which prevail in the domain of education for the retailer of talking machines. The subject is one of great interest and we commend these articles to the consideration of all who are devoting attention to the featuring and developing of the musical possibilities of the talking machine.]

THE SECRET OF DETAIL

Life consists of the details of life, and to live successfully is to know how the details should be looked after, and then to look after them.

Business success is like the art of living, for it is based on knowing the details and then successfully looking after them.

In the talking machine business, at least in its retail aspect, success consists in taking the greatest care of the small details. The man was wise who once said, "Give me the luxuries of life and I will let the necessities take care of themselves." A retail merchant in the talking machine business may rightly counter by saying: "Show me how to take care of the little, often unnoticed, things and I will show you the secret of success." For they are one and the same.

The talking machine is a musical instrument. On that we are all agreed. Like all works of mortal man the talking machine has its own defects and inconveniences. It is not entirely perfect. But the practical difference between practical perfection—that is to say, perfection to all intents and purposes—and complete imperfection is a difference extremely small and extremely easily bridged. Yet, it is a difference often not bridged at all.

In a word, the success, at retail, of the talking machine rests ultimately upon its ability to transmit in practical perfection to the ears of the hearer all kinds of fine music. There is, of

course, along with the fine in music, much that is not fine at all, but this does not matter for our purposes. It does not matter, that is to say, whether we do or do not take care of the little details when we are dealing with music of the frankly lowest type. But the sale of machines based on such music does not constitute the backbone of any retail business, nor does the sale of this type of records. In other words, one could do without the very cheapest and yet get along very nicely; but one cannot do without the high class, whether one may happen to like it personally or not.

Now, it is precisely in respect of all high-class selling, whether of machines or of records, that the attention to details, of which I speak, produces the desired results.

Mental Conditions and Detail

Last month a good deal was said about the influence of color in the decoration of demonstration rooms and in respect of its influence upon the attention and the general mental state of prospective purchasers who are listening to music. It is now time to talk about another item in the same department of thought. Let us consider, just for a moment, the influence of detail upon the mental state of the prospective buyer of machines or records.

The man or woman who goes into a talking machine store for the purpose of looking at a machine—that is to say, who is not an old customer calling to buy records, but a new customer just entering the talking machine game, as it were—is sure to have certain more or less incorrect preliminary ideas of the whole matter. The usual condition of the talking machines in use in the home of his friends is not sufficiently good, as a general thing, to enable anyone to

gain a true idea of what the machine will do. In the home the records become dusty, the motor squeaks and the sound box is perhaps loose in its bearing. Needles are used more than once, records are scratched by careless handling and a multitude of little annoyances are constantly being translated into inferior sound. Consequently, the very first consideration in a successful retail talking machine business should be regular inspection and maintenance of each and every demonstration machine.

What Regular Inspection Does

That means just what it says. Regular inspection means that each demonstrating machine should be looked over every morning. The motor should be tested for speed and oiled, if necessary, or otherwise adjusted. The sound box and tone arm should be inspected and adjusted. The old needles should be taken away and a supply of new needles put in, of all tone strengths. Dust should be wiped off the parts and the whole machine put into perfect condition. The job will take but a few minutes and the expense is negligible. Yet the result will be noticeable from the start. Let this thought be impressed upon every person who works in a retail talking machine store:

"Each machine and each record used for demonstration or sale in this institution must at all times be in perfect condition. It is a crime against the business of this institution to use, or permit the use of, equipment which is not in perfect condition."

On Record Maintenance

What has been said about machines in detail is also true as regards the stock of records. We have often been impressed with the difficulty of

RAINBOW SACRED RECORDS

Double Disc 85c.

RAINBOW RECORDS

HOMER RODEHEAVER, supreme in sacred song, records exclusively for Rainbow Records. His new songs can only be found on Rainbow Records.

Every dealer should stock the Rainbow Sacred Record Line for his Christmas trade. Write to your nearest distributor. Anticipate your Holiday needs immediately.

Rainbow Records have no season. They sell from January to December, year after year. No heavy stock. No old stock.

RODEHEAVER RECORD CO.

150 East 41st Street

New York

RAINBOW SACRED RECORDS

DISTRIBUTORS

ELITE PHONOGRAPH CO.

1626 Chestnut St.
Philadelphia, Pa.

STERLING ROLL & RECORD CO.

137 W. 4th St.
Cincinnati, O.

RODEHEAVER CO.

218 So. Wabash Ave.
Chicago, Ill.

J. K. POLK FURN. CO.

288 Decatur St.
Atlanta, Ga.

STERLING ROLL & RECORD CO.

434 4th Ave.
Pittsburgh, Pa.

RODEHEAVER CO.

814 Walnut St.
Philadelphia, Pa.



maintaining a large stock of records in perfect condition, nor is anyone likely to minimize that difficulty who has had practical acquaintance with the conditions of most retail stores. Yet it is essential that all records, at all times, should be in perfect condition, unscratched and clean, ready to do their work of reproduction perfectly at any moment without notice. This means that the stock of records needs to be handled with great care by persons who understand the importance of care. It also means that special precautions must be taken against damage in handling. Now, the best experience of the best stores shows plainly that if each record is kept always in its envelope and is never allowed outside that envelope, save when it is actually being demonstrated, the chances of its being damaged will be very small indeed.

Records used for demonstration purposes should be handled only by the salesman who is demonstrating, and there should be in each and every demonstration booth a soft feather brush, wherewith each record may be dusted off carefully before and after it is used. Personally, we believe that the little record brush is a very useful accessory to every talking machine.

This consideration leads us to remember that, in the usual way of arranging demonstration booths, the record racks are arranged in a passageway which runs the length of the line of booths, each of which has a door opening into the passage. With this arrangement the salesman can at once procure from those who are attending to the record stock any record needed, and can give good and rapid service to the customer.

Eliminating Noise

Another little detail that is often neglected, but which is very important, is the detail of noise behind the demonstrating rooms. It does not cost much to lay a thick carpet along the passageway on which about the record shelves. It does not cost much, but the detail is often neglected. Yet, to neglect that detail is to make a very serious mistake. Noise must be eliminated to the very utmost of practical possibility. For this very same reason doors leading into demonstration booths ought not to be loose, banging affairs as, unfortunately, they often become. What is the use of spending all kinds of money on nice furnishings, appropriate color schemes, thick carpets, etc., etc., if the doors will either not stay shut or else are constantly banging and squeaking whenever they are moved? Again, let it be noted that noiseless operation is the essen-

tial of successful retail merchandising of talking machines and records.

Now, all these details have a definite relation to the musical possibilities of the talking machine, which form the text or subject matter of these articles. The essence of good retailing of talking machines is found in the knowledge that it is music which we are selling and not machinery. When we realize this, when we think always of the music first and of the machinery only later, when we think always of what the machinery and the material are doing, instead of how they are made and what they cost, then we—from the salesman's point of view—are doing the right thing in salesmanship. That is why we need to be so very fussy over the little details of service. The selling of music is in every essential the selling of a very delicate service to a very delicate art. It cannot be trifled with. If it is handled roughly it dies. The musical possibilities of the talking machine are infinite, but they cannot be exploited by careless, indifferent or ignorant methods.

Care for details is the secret of success in music selling. Talking machine selling and record selling constitute one of the most important branches of music selling. Wherefore this article.

MAGNAVOX SOLD TO NAVY YARD

Will Be Used to Assist in Moving Vessels in Drydock—N. Z. Bishop Joins Magnavox Sales Staff—Located in New York Office

Among the recent sales made by the New York office of the Magnavox Co. was one to the Navy Yard at Brooklyn. E. A. Davis, Eastern sales manager for the Magnavox, installed the equipment, which will be used by Navy officials in the mooring of vessels in drydock. By the use of the Magnavox an officer placed at some vantage point away from the vessel will be able to direct the work of docking at a great saving of time, and also much more easily and efficiently.

N. Z. Bishop, who has been connected with the radio and wireless branch of the Naval Aviation Service for the past three years, recently joined the sales force of the Magnavox. Mr. Bishop will be located in the New York office and will center his activities in metropolitan New York and New Jersey, calling on the trade in the interests of the various Magnavox amplifiers. As Mr. Bishop's work in the Navy was particularly pertinent to the Magnavox, his experience will assist him materially in his new position.

The
Tiffany

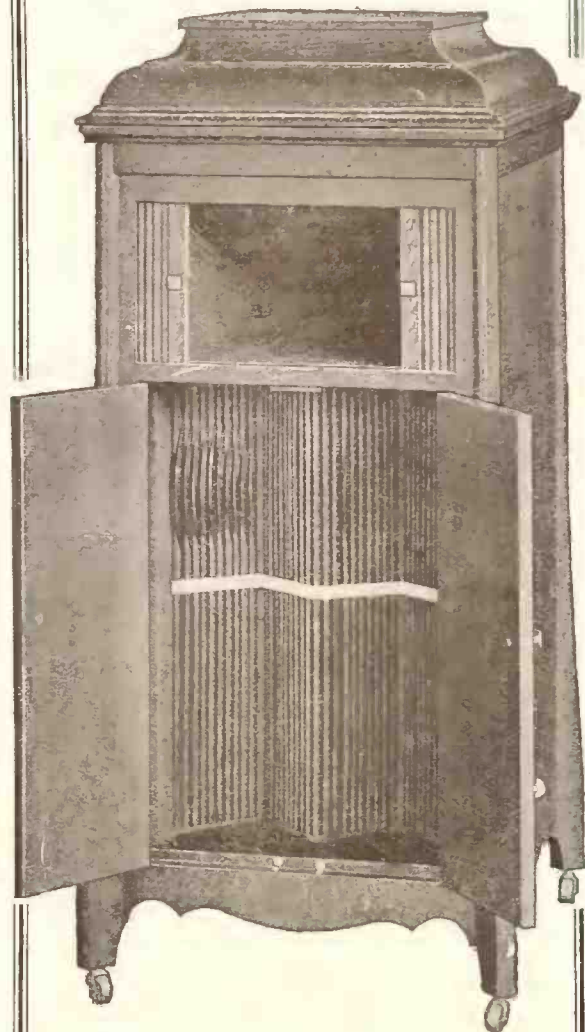

"Stands for Quality"

The appealing lines of the Tiffany phonograph, together with its wonderful tonal qualities and cabinet construction, are the reasons for the noticeable increase in Tiffany Dealers.

Write for our attractive proposition.

Distributors for Jones-Motrolas and Cardinal Records.

Tiffany Phonograph Sales Co.

Executive and Sales Offices
1404 East Ninth St. Cleveland, Ohio

CHENEY FOR JAPANESE PRINCE

Makes Selection of Style 110 During Visit to New York Last Week

A Cheney phonograph will shortly grace one of the palaces of Japan. G. D. Shewell, president of the Cheney Sales Corp., of New York and Philadelphia, told how the New York offices of the company were recently honored by a visit from Prince Asakira of the Japanese battleship "Izumo." This battleship, together with a sister ship, was anchored in the Hudson River for a week or so during the early part of the month. Prince Asakira had heard the Cheney phonograph in Japan and upon his arrival in New York visited the offices of the Cheney Sales Corp., distributor of the Cheney phonograph, attended by a suite of fifteen officers. The prince was enthusiastic over the tone of the Cheney and purchased Style 110, one of the handsomest models in the line. Style 110 is a console model and is an excellent piece of cabinet work. The machine was immediately delivered to the flagship "Izumo" and carried thence to Japan.

SOSS

INVISIBLE HINGES



Soss Invisible Hinges

are essential to preserve the beauty of design, particularly when it is desired to disguise the talking machine cabinet. In many of the better cabinets of today Soss Hinges are used. They are mechanically accurate and can be installed quickly and easily.

Write for Catalogue

SOSS MANUFACTURING COMPANY
778 Bergen Street, Brooklyn, N. Y.

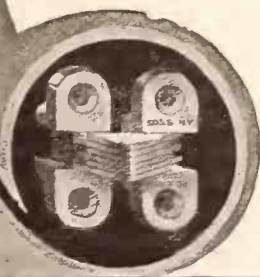

TRADE ASSOCIATION OF LOS ANGELES ELECTS OFFICERS

J. W. Boothe Elected President—Appreciation of Work of Evening Express—Noted Orchestra Heard—Victrola for the Movies—Talking Machine Men Go After Fish—and the Results

LOS ANGELES, CAL., November 3.—The annual meeting of the Music Trades Association of Southern California for the election of officers took place last month with the following result: J. W. Boothe, general manager of the music department of Barker Bros., was elected president; George H. Barnes, president of the Barnes Music Co., first vice-president; Alfred C. Danz, of the Crescent Music House, second vice-president; Harold Jackson, treasurer, and A. G. Farquharson as secretary. A rising vote of thanks was given to E. A. Geissler, retiring president. A number of important matters were discussed during the evening by the members, who attended in large force.

Letter of Thanks Sent to Newspaper

The daily talking machine record concerts which are being given by the Los Angeles Evening Express, which consist of the playing of ten

records of one make at each concert—eight makes being represented and given on separate days so that eight concerts of each make of record are given, a total of sixty-four concerts are progressing with marked success. At the annual meeting of the Music Trades Association of Southern California a vote of thanks to the Los Angeles Evening Express was tendered and the following letter addressed to Frederick W. Kellogg, manager and owner of the Express: "The members of the Music Trades Association of Southern California wish to express their appreciation of the plan put forward by the Los Angeles Evening Express for the advancement of music through the phonograph record, and by means of sixty-four concerts being held at the Express Auditorium.

"They appreciate the wonderful value to music which is being given through editorial and news

publicity by the Los Angeles Evening Express and recognize the generosity shown in the giving of cash prizes for encouragement to those of the public who interest themselves in these concerts.

"At the same time they wish to pledge their unanimous support and co-operation in this excellent and altogether novel idea."

Irving C. Franklin Gives Interesting Talk

Irving C. Franklin, general sales manager of the Burnham Phonograph Corp. gave a very interesting talk to the members of the Music Trades Association of Southern California at its annual meeting. He gave a brief history of the Burnham Co. and outlined the policies adopted, which were in strict accordance with the rules of the Association.

Portable Victrola for Movies

The adaptability of the new portable Victrola has been quickly recognized by the motion picture people and Cecil B. de Mille, famous producer, purchased one of these little instruments from Richardson's, Inc., last week. Motion picture actors and actresses, particularly the latter, find that music, as an inspiration, is a necessity, and music is seldom missing during the "shooting" of a scene for a picture; therefore, when on "location"—away from the studio or lot—what could be more convenient than the portable?

Max Fisher Plays at Alexandria

Max Fisher and his orchestra, direct from the Ziegfeld "Midnight Follies" and Ritz Carlton, New York, are playing regularly at the Hotel Alexandria. They have recorded several dance selections for Vocalion records and Vocalion dealers have been quick to take advantage of this local publicity. The Max Fisher Orchestra, recording nationally known records, constitutes the third orchestra of this kind to make its home in Los Angeles; the Art Hickman Orchestra, known everywhere through Columbia records, has taken permanent quarters at the Ambassador Hotel, Los Angeles, while the Rudy Wiedoeft Orchestra, of Brunswick record fame, is heard daily at the Cinderella Roof Garden.

Ralph Paulin in Los Angeles

Ralph Paulin, president and general manager of the Paulin Music Co., Santa Barbara, was in Los Angeles last week for a couple of days. He reports good business conditions in Santa Barbara. The old adobe house immediately adjacent to the Paulin store, which is one of the oldest buildings in Santa Barbara, and has solid walls of three feet in thickness, is wonderfully attractive as a recital hall and period models—Victrolas and Brunswicks—can be demonstrated under ideal conditions.

Music by Radio

Hamburger's wireless on the roof of their great eight-story building is being utilized to transmit Brunswick records far and wide. Every day at 3 p. m. and 8 p. m. anyone within two thousand miles of Los Angeles can "listen in" and hear the six latest Brunswick records.

Three Fishers Went—

Irving C. Andrews, of the Andrews Talking Machine Co., and Harold Jackson, manager of the phonograph department of the Wiley B. Allen Co., hungered for a last frying pan or two of trout before the close of the season. Conditions looked good—two days before the thermometer had registered somewhere around 90 degrees in Los Angeles shade: pine trees and cool trout pools a mile or so above seemed tempting. However, a possibility of bad weather existed and it was desirable to take along a mascot, and so they selected the secretary of the Music Trades Association of Southern California. They waxed eloquent and with fishy word pictures easily secured the mascot and the dawn of a Sunday saw the three spinning over the road toward San Bernardino and the rim of the world beyond. There was a fine rain descending, described as fog by the two optimists. Five hours later they pitched camp at Camp Alison, 6,150 feet up; an ancient Irishman in charge predicted snow—"and if it sh-tarts ye had better be moving while ye can." Nothing daunted, lunch was



Style R

**Business Will Be Better for
the Holidays If You Have
a Complete Line of**

KIMBALL PHONOGRAPHS

*Send your order at once that you
may not be disappointed*

Kimball Phonographs are made in distinctive designs and are of superior construction. They reproduce the natural tone recorded in the record. Kimball prestige has established a ready market for this product.

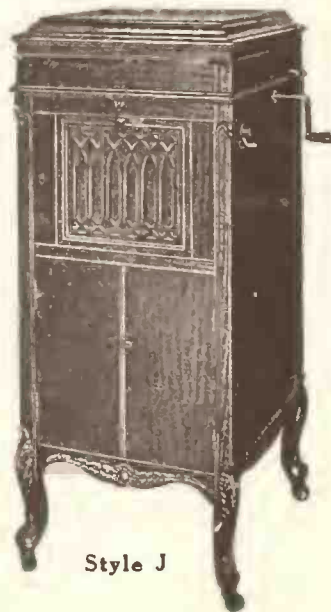

Style J

Write for Agency Proposition

W. W. KIMBALL CO.

Established 1857

306 S. Wabash Ave., Kimball Bldg.
CHICAGO

*Manufacturers of Phonographs, Pianos, Player-Pianos,
Pipe Organs, Distributors of Okeh Records*



Style D

THREE HANDSOME NEW VICTROLAS IN PERIOD DESIGNS

Victor Talking Machine Co. Announces New Upright Victrolas in Jacobean, William and Mary and Chippendale—All Period Designs Which Should Make a Wide Appeal to Dealers and Public

The Victor Talking Machine Co. has announced three new Victrola models in period

the first period styles in such machines to be marketed by the company.

The new period Victrolas will be known as the

and are listed at \$575, \$600 and \$700 respectively. All three models have the regular Victor four-spring motor and standard reproducing equipment. The Chippendale is in mahogany, the Jacobean in fumed oak and the William and Mary in American walnut.

It is stated that a limited number of the new

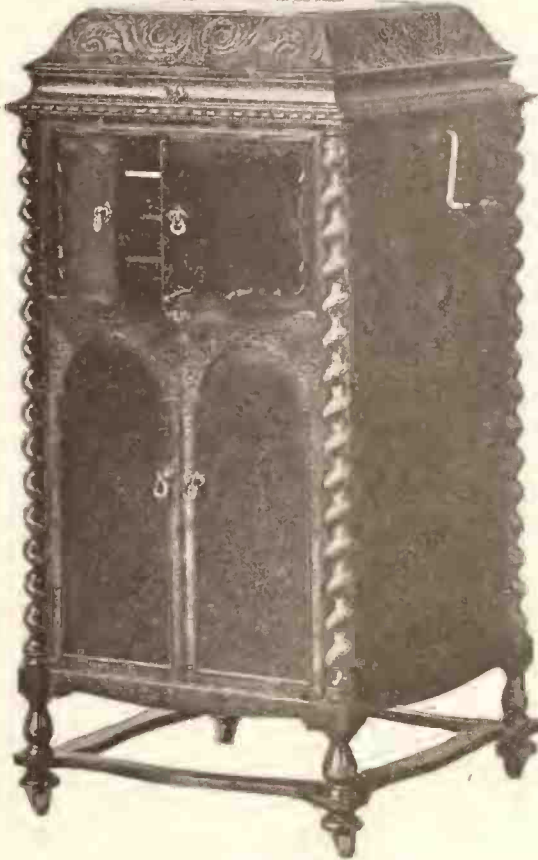

Period Victrola—Jacobean, No. 2 designs, the announcement being of unusual interest in that all three models are uprights and

Period Victrola—William and Mary, No. 0 Chippendale No. 2 upright, the Jacobean No. 2 upright and the William and Mary No. 0 upright,

Period Victrola—Chippendale, No. 2 models will be ready for shipment to the trade at an early date.

TRADE NEWS FROM LOS ANGELES

(Continued from page 156)

eaten amid the strain of McCormack's "Foggy Dew," and then a start was made on the trail to Deep Creek, two and a half miles away downhill. It commenced to rain soon afterwards and by the time Deep Creek was reached it was pouring. Ten minutes' fishing under these conditions was so dampening that the last spark of enthusiasm was extinguished and the long climb back to camp was made, the rain turning

to snow as the top was reached. Mindful of the old Irishman's warning, camp was soon broken and a sodden load of tent and fishermen drove down the tortuous steep grade to San Bernardino and then home. The fish was fried in the Jackson kitchen next morning—it was remarkable for its size, poor little thing.

PROTEST "NO PARKING" ORDINANCE

Washington Music Merchants Declare Rule Would Drive Away Much of Their Trade

WASHINGTON, D. C., November 4.—Local music dealers are much wrought up over the proposed order of the Commissioners of the District of Columbia to prohibit the parking of automobiles in the business section.

Music dealers point out that the proposed order would drive away the out-of-town trade that the business men of Washington have tried so hard to persuade to come to the city and would materially hamper them in building up trade in residential sections, where there are neighborhood music stores. It is pointed out that if a person is compelled to park a half mile or more from the downtown stores the neighborhood establishments are likely to profit materially from the fact that customers can drive right up to their doors and park for an indefinite period.

Protests against the proposed regulations are descending upon the Commissioners in a flood and it is probable that the action actually taken will be considerably less severe than was originally suggested.

CREMONA PHONOGRAPH CO. AFFAIRS

PORTLAND, ORE., November 4.—The total amount of debts of the Cremona Phonograph Co., which recently went into bankruptcy, was \$107,782.01, while the assets amounted to only \$31,666.39, according to the account filed in the Federal Court by the secretary of the company, H. E. Witham. The secured claims amounted to \$62,075.37 and \$40,640.25 were unsecured claims. The real estate was listed at \$6,050 and bills, notes, etc., were to the amount of \$23,845.08.

Charles Feldman, manager of the United Talking Machine Co., of Brockton, Mass., was married last week to Miss Cecil Terr, of Dorchester, Mass. The couple are spending their honeymoon in Bermuda.

Mr. Dealer



Please let us explain why we sold six hundred Robinola Talking Machines from our office at retail within a short time. Let us send you a list of the purchasers. We will send you a sample at a price that will startle you. Then, after you test the Robinola, you will say that it is the first

talking machine you ever heard absolutely free from needle scratch and metallic sound. Write now before you forget it.

ROBINOLA TALKING MACHINE CO., Inc.

119 East 5th Street CINCINNATI, OHIO



Main-Springs

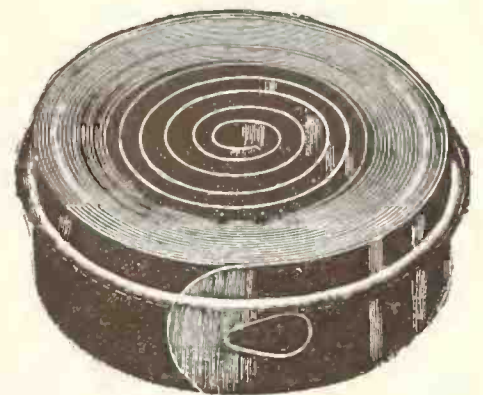

For any Phonograph Motor Best Tempered Steel

Size	Material	Price
3/8 inch x 10 feet	for all small motors	Each \$.40
1/2 " x 10 "	Pathe, Columbia, Heineman	.45
1 " x 10 "	Columbia	.50
1 " x 11 "	Columbia with hooks	.55
1 " x 13 "	Victor, old style	.50
1 " x 15 "	Victor, new style	.55
1 1/2 " x 18 "	Victor, new or old style	.75
1 " x 12 "	Heineman and Pathe	.55
1 " x 10 "	Saal, Silvertone, Krasberg	.55
1 " x 13 "	Saal, Silvertone, Brunswick	.65
1 " x 16 "	Sonora, Brunswick, Saal	.75
1 3/16" x 18 "	Heineman and Pathe	1.00
1 1/2 " x 25 "	Edison Disc	1.80

SAPPHIRES—GENUINE
Pathe, very loud tone, each 15c, 100 lots \$11.00.
Edison Loud-tone, each 15c; in 100 lots, \$11.50.

PHONE-ARMS
The very best, loud and clear, throw-back.....\$5.00
With large reproducer, very loud, Universal..... 4.50
With smaller reproducer, but loud and clear..... 3.00

PHONOGRAPH NEEDLES
We can give you best price on Brilliantone, Magnedo, Wall-Kane, Tonofone, Nupoint, Gift Edge, Incas and Velvotone Needles.

ORDER RIGHT FROM THIS AD
Send for price list of other repair parts and motors.
Terms—F. O. B. St. Louis, Mo. Send enough to cover postage or goods will be shipped by express.

The Val's Accessory House
1000-1002 Pine St. St. Louis, Mo.

ST. LOUIS TRADE LOOKS FOR ACTIVE HOLIDAY BUSINESS

With Railroad Strike Removed Dealers Are Ordering Heavily and Distributors Are Optimistic Regarding Outlook—Announcements of New Dealers and Departments—Activities in Sales Fields

ST. LOUIS, Mo., November 5.—The talking machine business, depressed during October by the threatened railroad strike, rebounded promptly when that menace was removed. The beneficial effect was particularly noticeable in the wholesale end of the business. Dealers were wary of ordering while the strike cloud was hovering. Immediately after the announcement that there was to be no strike, orders that had been withheld began coming into the wholesale departments of all the distributors. With no industrial disturbance in prospect distributors and dealers anticipate very good business from now until the holidays. In St. Louis the highest grade machines are holding their own pretty well against the rising demand for the medium grades, but in the smaller places the call is mostly for cheaper machines. This is reflected in the orders from dealers in the country. Distributors are accommodating themselves to this development, looking upon it as a healthy tendency toward a better balanced movement. The Silverstone Music Co., Edison distributor, has not only been adapting itself to the development, but has been encouraging it by a campaign in favor of the Heppelwhite Model, which sells for \$167.50. The dealers have been taking kindly to it and the indications are that outside of St. Louis the Heppelwhite will be the leader in Edison sales for Christmas delivery.

Tone-Test Attracts Crowds

The tone-test given by the Silverstone Co. at Moolah Temple on Saturday, October 30, was one of the most successful ever given in St. Louis. The auditorium was crowded, the attendance being estimated at 2,800. Miss Amy Ellerman, contralto, and Miss Vera Barstow, violinist, assisted by Calvin Coxe, tenor, were the artists.

November is the anniversary month of the Scruggs, Vandervoort & Barney store, and all

departments make special efforts. The talking machine department is offering unusual inducements.

Take on the Brunswick Line

The Lehman Piano Co., which recently moved to the northwest corner of Eleventh and Olive streets, has added the Brunswick to its lineup of talking machines. The contract was closed late in October and a full line of machines was delivered. C. F. Shaw, city salesman, handled the deal. The Lehman Co. has been handling the Vocalion and the Columbia.

Miss Dorothy Jardon, Brunswick artist, was at the Orpheum the first week in November. Brunswick dealers rose to the occasion by making special window exhibits and by co-operative advertising.

C. F. Shaw, city salesman of the Brunswick Co., was called to Jackson, Tenn., early in November by the critical illness of a relative.

Has New Victrola Department

Hellrung & Grimm, Ninth street and Washington avenue, have a new Victrola department on the main floor. There are a number of sound-proof rooms, restful in garb of old ivory, enlivened with touches of cretonne. There is a convenient record counter.

Col. F. B. T. Hollenberg, president of the Hollenberg Music Co., Little Rock, Ark., was in St. Louis recently.

Mrs. L. E. Gholson is continuing the business at Sessor, Ill., of her husband, who died recently, and will continue to handle the Brunswick machines.

New Home of Wellston Talking Machine Co.

The police had to be called to keep out the crowd whose pressure at one time threatened the glass of the beautiful show windows at the new home of the Wellston Talking Machine Co. F. Coleman has been a dealer solely in Victrolas and Victor records for many years, and recently

opened a handsome new store. The booths and woodwork are finished in ivory and old ivory with silver lighting fixtures. Three thousand Penn dogs were given as souvenirs. Mr. Coleman's neighboring dealers showed the high esteem in which he is held by filling the house with flowers. This shop has the unique distinction of employing no outsider, the work being carried on by Mr. and Mrs. Coleman, with their daughter and son-in-law, Mr. and Mrs. C. A. Dieke.

Changes in Selling Staffs

Many changes in the selling staffs of various St. Louis Victor houses are taking place. At Stix, Baer & Fuller, the new ones are Miss Lacey McGhee, Miss Katherine Walsh, Mrs. Billie Ladd and Miss Evelyn Nagel. At Field-Lippman's are Miss Laura Hagge and Mrs. K. Holland, formerly with Sanger Bros., Dallas, Tex. At Glaser's Music Shop is Miss Betty Zlotnik.

Latest Brunswick Dealers

The following Brunswick franchises have been placed recently: King Jewelry Co., Coulterville, Ill.; Harrisburg Music Co., Harrisburg, Ill.; H. C. McClure, Versailles, Mo.; Vassel & Voss, Centralia, Ill.; Arthur A. Schultz, Washington, Mo.; A. J. Hampton, Herrin, Ill. The Harrisburg Music Co. is a new company, composed of J. F. Wilson and J. E. Smith.

Briefs of Interest

Miss Grace Haddick, formerly with the Koerber-Brenner Co., has taken a position with the Zerweck Music Co., Brunswick dealer at East St. Louis, Ill.

D. A. Robnett, of the Parker Furniture Co., Edison dealer at Columbia, Mo., died recently.

The Edison slogan, "The Thing Beyond the Thing Beyond," was recently made the subject of a sermon by the Rev. W. H. Whitlock at the First M. E. Church, Belleville, Ill., after it had been brought to his attention at a demonstration there.

D. G. Garrison, of the G.-W.-B. Music Co., Marion, Ill., was a recent visitor to St. Louis.

Silverstone Makes Complaint

The Globe-Democrat is giving away "Phon-Olas" for subscriptions. There is no objection to that, but talking machine dealers are protesting against the impression given in the advertising that the "Phon-Ola" is a regular talking machine. Mark Silverstone, president of the Silverstone Music Co., has made a complaint in the name of the Music Merchants' Association of St. Louis. Letters of protest are said to have been sent in by several. It is desired to have the dimensions of the machine published, so that the public will know what it is and not be misled into the presumption that it is grown up.

Completes Salesmanship Class

The Koerber-Brenner Co. has just completed a salesmanship class which, in spite of the lateness of the season, had nine people enrolled. In addition to the usual work covered, E. C. Rauth, who has just returned from a week's stay at the Victor factory, gave two very instructive lectures. M. de C. Freeman also talked to the class. On Monday the Eight Victor Artists were in evidence, and the class occupied a box at their concert that night.

Increases Capacity of Victor Department

The Cline-Vick Drug Co., of Marion, Ill., has tripled the capacity of its Victor department recently, adding sound-proof bearing rooms, built-in record racks of the latest design and a handsome service counter.

Red Seal "Derby"

Stix, Baer & Fuller, St. Louis, are conducting a Red Seal "Derby" in their Victrola department. To the winner each month is given a pair of tickets to any show or concert in the city. The question in the department at the end of the day now is, "How many Red Seals have you sold?" not as formerly, "What is your summary?" Miss Mae Kennedy was the winner for September and is leading the race for October.

The Silverstone Music Co. took advantage of the recent celebration of the 100th anniversary of Missouri's statehood by preparing a specially arranged window calling attention to some of the things that were not enjoyed 100 years ago. Gen. Lafayette, in animated figure, was pressed

"PERFECTO"



Unexcelled in Tone and Beauty

BEING experts in this line for years, formerly connected with the largest phonograph manufacturing concerns in the world, we are now manufacturing a *High Grade Phonograph Unexcelled in Beauty and Tone*, with the newest improvements of any other kind on the market, possessing the best in material and workmanship.

Save the middleman's profit and deal direct with the manufacturer. We invite the trade to our factory.

Size of this Model

23" wide, 24" deep, 50" high

in Genuine Mahogany
and American Walnut

Perfection Phonograph Co.

Factory and Showroom:

203 LEWIS ST., Cor. 6th St.
NEW YORK

Telephone Dry Dock 4835

into service to remind the public, by means of placards held in his moving hands, that 100 years ago there was no talking machine, no telephone and no electric light—and no Thomas A. Edison.

Columbia Happenings

H. L. Tuers, manager of the Dealer Service department of the Columbia Graphophone Co., made a flying trip from New York to put over some new ideas for aiding the dealers during the coming rush season.

Robert Porter, field sales manager of the Columbia Co., spent a day here last week tuning up the sales force to further efficiency and suggesting further ways of a closer co-operation between the dealers and the salesmen.

E. M. Morgan, branch manager of the Columbia Co., has just returned from a brief trip through the Illinois territory and reports that the dealers in that section are decidedly optimistic with regard to the coming holiday season and are already showing unusual activity in sales. Mr. Morgan left for Pittsburgh, Pa., on a several days' business trip.

The St. Louis branch of the Columbia Co. announces with regret the resignation of R. N. Johnson, Dealer Service supervisor, after an impeccable record of four years' service with the company. George T. Harris is his successor.

Miss Florence Hazlett, representative of the educational department of the Columbia Co., visited the St. Louis office and reports record-breaking business in the department.

INTRODUCE TWO NEW SALES HELPS

New Table for Victrolas 4 and 6 Designed by the Unit Construction Co. Now Ready

PHILADELPHIA, PA., November 7.—The Unit Construction Co., of this city, manufacturer of "Unico" equipment for talking machine warehouses, has placed on the market two new sales helps particularly designed for the talking machine dealer and one which may be resold by the dealer. The "Unico" Sales Stimulator is a selling aid to be placed on the wall of the demonstrating room. Two records are displayed with space beneath each for a descriptive card. Two labeled pockets are provided, one for records selected and the other for those not desired. The other number produced is known as the "Unico" stand No. 46, and consists of units which may be assembled rapidly, and is somewhat similar to the table announced last month for the portable, except that this new table is designed particularly for Victrolas 4 and 6.

Robert L. Foord has opened the Talking Machine Shop at 416 Market street, Wilmington, Del. Victrolas and Victor records are handled exclusively.

U. S. Player Rolls

At Your Own Price

We are confining our business strictly to Talking Machine Accessories and have several thousand rolls to sell at auction by mail. Will gladly send you a list of numbers on hand. *Make your bid.*

WALTER S. GRAY CO.
942 Market Street, San Francisco

RECORD MUSIC SPANS CONTINENT

Records Played in San Francisco in Armistice Day Test Heard by Crowds in Arlington Cemetery, Where Unknown Soldier Will Lie

WASHINGTON, D. C., November 4.—The call of a bugle, the chime of bells and the voice of a man sounded across the continent from San Francisco yesterday to be magnified over a wide area about the Arlington National Cemetery, with every note, every tone of the bells and every spoken syllable as distinct as though produced a hundred feet from the listeners' ears.

The speaker stood on the roof of the great Civic Auditorium in San Francisco and the music came from talking machine records played in the building on which he stood. It was the formal rehearsal of the mechanism by which President Harding's voice, as he speaks the Nation's homage on Armistice Day over the coffin of America's unknown dead from France, will be carried to an audience waiting before the amplifiers in New York and to another gathering in San Francisco to share in America's great day of tribute.

There was a long reading of speeches from the stage of the amphitheatre here to be carried over the wires to San Francisco. Then the voice announced that the next words to be heard would be spoken in San Francisco. The faint whir of the mechanism rose to a higher hum and a new, deeper-toned voice announced that chimes, played on a talking machine record in San Francisco, would come next. As clearly as if it were not a dozen feet away there came the click as the needle dropped on the face of the whirling record disc 3,000 miles away; the familiar introductory scrape began, then the bells boomed out, waking echoes in the cemetery and pealing over the thousands of graves.

The deep voice took up the task again, reading the words of President Harding's inaugural address. Then it announced the bugle record, and the clear note of a trumpet in stirring army calls sounded over the field, more distinctly heard than the notes of the bugles at Fort Myer across the road, where the garrison was at retreat parade.

OPENING OF DALES' NEW TEMPLE

Enjoyable Musical Program Entertains Crowds Who Visit New Establishment Opened by Geo. S. Dales in Akron

AKRON, O., November 8.—Dales' New Temple of Business, which sobriquet has been given the new basement talking machine parlors just completed, at a cost of approximately \$5,000, by G. S. Dales, was opened to the public Thursday evening. The temple is something entirely new to the talking machine store life of Akron and the innovation made a decided hit with several hundred of the trade who accepted the invitation of Mr. Dales to inspect the new department and enjoy the concert and dancing.

For those who are musically inclined the store arranged a pleasing concert, offering Mrs. Chandler and John Stein in vocal numbers and an opera lecture by Prof. Hantleman. On the main Victrola floor dancing was the entertaining feature during the evening. There was no admission charge and, according to Mr. Dales, the store will continue these Thursday night concerts throughout the Winter.

"Business in the talking machine trade, as I view it, is about 15 per cent better than it has been," said George S. Dales in an interview with a representative of The World. "I have much confidence in the future and predict a satisfactory volume of business for the two months to come, with a decided improvement along about December 1. The holiday trade should be a big improvement over last year." Mr. Dales says his record business has been very satisfactory the past several weeks.

Dealers should not overlook the value of local advertising in calling attention to the line of holiday products which they are handling.

ARTO RECORDS



ARTO Record Releases for the Month of DECEMBER, 1921

- DANCE RECORDS**
- 9106 Weep No More, My Mammy (L. Pollack). Fox-trot. Louis Cohen and His Orchestra
 - Crooning (W. F. Caesar-B. Perkins). Introducing "Love Me All of the Time." Medley Fox-trot. Merry Melody Men
 - 9107 Birds of a Feather (J. McGowan-E. Moran). Fox-trot. Louis Cohen and His Orchestra
 - Glow, Little Lantern of Love (F. Fisher). Fox-trot. Louis Cohen and His Orchestra
 - 9108 Everybody Step (I. Berlin). From "Music Box Revue." Fox-trot. ARTO Dance Orchestra
 - Song of Love (S. Romberg). From "Blossom Time." Waltz. ARTO Dance Orchestra

- POPULAR VOCAL RECORDS**
- 9104 When Francis Dances With Me (B. Ryan-Violinsky). Baritone Solo, Orch. Accom. Arthur Fields
 - Ten Little Fingers and Ten Little Toes Down in Tennessee (Pease-Schuster-Nelson). Tenor Solo, Orch. Accom. Arthur Hall
 - 9109 That's How I Believe in You (Dubin-Cunningham-Rule). Duet, Tenors. Charles Harrison-Everett Clark
 - Feather-Bed Lane (Bryan-Paley-Gumble). Tenor Solo, Orch. Accom. Sam Ash
 - 9110 I Ain't Gonna Be Nobody's Fool (F. Davis-G. Bennett). Contralto Solo, Orch. Accom. Dorothy Dodd
 - I've Got the Blues, But I'm Just Too Mean to Cry (Parish-Young-Squires). Contralto Solo, Orch. Accom. Dorothy Dodd

- COLORED VOCAL "BLUES" RECORD**
- 9105 Mississippi Blues (Spencer Williams). Vocal Blues. Contralto Solo, Orch. Accom. Alice Leslie Carter
 - Wabash Blues (D. Bingle-P. Meinken). Vocal Blues. Contralto Solo, Orch. Accom. Lucille Hegamin
 - 9112 Decatur Street Blues (Clarence Williams). Vocal Blues. Contralto Solo, Accom. by Jimmie Johnson's Jazz Boys. Alice Leslie Carter
 - Got to Have My Daddy Blues (E. Erdman-C. Jones). Vocal Blues. Contralto Solo, Orch. Accom. Alice Leslie Carter

- HAWAIIAN RECORD**
- 9111 Susquehanna Shore (H. D. Squires). Waltz Duet, Hawaiian Guitars. Ferera-Franchini
 - When Sweethearts Waltz (C. De Voll-L. Breau). Waltz Duet, Hawaiian Guitars. Ferera-Franchini

- CHRISTMAS NOVELTY RECORD**
- 3089 Santa Claus Arrives (G. Gerard). Descriptive Specialty. Gilbert Gerard
 - Santa Claus Builds His Toys (G. Gerard). Descriptive Specialty. Gilbert Gerard

- STANDARD VOCAL RECORD**
- 3084 Silent Night, Holy Night (F. Gruber). Contralto Solo, Orch. Accom. Nevada Vanderveer
 - O Holy Night (A. Adam). Contralto Solo, Orch. Accom. Nevada Vanderveer

- OPERATIC ARIAS (Sung in Italian)**
- 3085 Rigoletto. "La Donna Mobile" (G. Verdi). Tenor Solo, Orch. Accom. Antonio Rocca
 - Rigoletto. "Cortigiani Vii' Raizza Dannata" (G. Verdi). Baritone Solo, Orch. Accom. Carlo Ferretti
 - 3086 Cavalleria Rusticana. "Brindisi" (P. Mascagni). Tenor Solo, Orch. Accom. Antonio Rocca
 - Il Flauto Magico. "Aria Della Regina" (W. A. Mozart). Soprano Solo, Orch. Accom. Eva Leoni
 - 3087 Zaza. "Piccola Zingara" (B. Leoncavallo). Baritone Solo, Orch. Accom. Carlo Ferretti
 - Cavalleria Rusticana. "Voi Lo Sapate" (P. Mascagni). Soprano Solo, Orch. Accom. Mme. Genie Fonarlova
 - 3088 Faust. "Dio Possente" (C. Gounod). Baritone Solo, Orch. Accom. Milo Picco
 - La Tosca. "Vissi d'Arto E d'Amor" (G. Puccini). Soprano Solo, Orch. Accom. Mme. Genie Fonarlova



- LIST OF ARTO DISTRIBUTORS**
- CROWN MUSIC CO., New York City.
 - ARTO DISTRIBUTING CO., New York City.
 - THE MORRIS MUSIC PUB. CO., Philadelphia, Pa.
 - CONSOLIDATED TALKING MACH. CO., Chicago, Ill.
 - SCOVILLE JOBBING CO., Atlanta, Ga.

We want more Distributors for un-appointed territories, therefore invite established firms to apply to:

THE ARTO CO.
1658 Broadway, New York City



The Columbians, our newest dance organization, play "Say It With Music" from Irving Berlin's *Music Box Revue* and "Just Like a Rainbow," both novel and full of color, both sure-fire hits. A-3472.

Columbia Graphophone Co.
NEW YORK

WASHINGTON DEALERS ARE ACTIVE

Several New Establishments Opened and Others Enlarged to Handle the Business

WASHINGTON, D. C., November 7.—The talking machine trade in the National Capital during the next few months will be the largest in the history of the trade, according to even the most conservative of dealers.

The Fall season has been marked by the opening of a new exclusively Victor retail house, a new Victor wholesale house, an extensive enlargement of the talking machine departments of two establishments, and the announcement of the opening of a new music store by the United Phonograph Stores, Inc. The new chain music store will be located in the beautiful new building being erected by the City Club on G street between Thirteenth and Fourteenth streets Northwest.

During the month the three-story Victor wholesale house erected by Rogers & Fischer, at 1219 I street Northwest, was completed and opened for business.

Louis & Co. completed the interior of their large new Victor retail house at Seventh and G streets Northwest, and have closed an unexpectedly successful month.

The Columbia and Brunswick department of J. Edgar Robinson was greatly enlarged, two additional booths and almost double the amount of shelf space being installed. In addition a large room is being prepared on the second floor

of the building for the exhibiting of talking machines. This room will be furnished as closely as possible like the average home parlor so that customers may secure an accurate estimation of the effect of the instrument in their own homes. Comfortable chairs and sofas, curtained windows and an open fireplace are some of the attractive features of the demonstration room.

The Gibson Co. during the month opened for business an enlarged phonograph shop at 917-919 G street Northwest. The New Edison and Brunswick phonographs and records are handled here.

Hugo Worch, handling the Victor and Columbia lines, reports a good market for instruments, though the usual seasonal increase in demand for records is a bit tardy.

The Sonora and Silvertone instruments are selling well at the Arthur Jordan Piano Co., Homer L. Kitt, secretary-treasurer, reports.

OPENS AN EXCLUSIVE VICTOR SHOP

PHILADELPHIA, PA., November 7.—On Saturday last Morris C. Rath opened an exclusive Victor machine and record shop at 6928 Market street, Upper Darby, in a rapidly growing section of the city. He has installed a number of hearing booths and will no doubt do a very good business in his line, as there are no competitors in the immediate vicinity.

In business the greatest and rarest quality is plain horse-sense.

MAKING "SAX-O-PHONEY BLUES"

Mamie Smith Visits Okeh Laboratory to Make Popular "Blues" Record—Number Being Used on Her Concert Tour—A Big Favorite

The accompanying photograph was taken recently at the Okeh laboratory in New York when Mamie Smith, the famous "Blues" singer and exclusive Okeh record artist, visited the laboratory for the purpose of making a record of

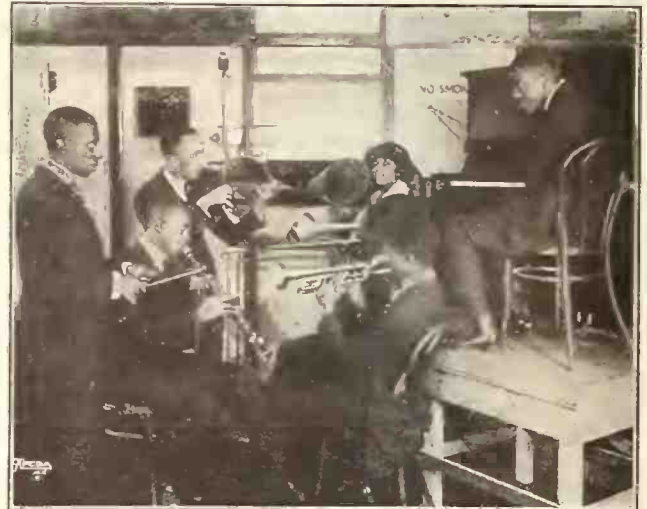

Taken in the Okeh Laboratory

"Sax-O-Phoney Blues." This new number by Milo Rega is creating a sensation, and Miss Smith is using it at every concert on her present tour.

Miss Smith is keenly enthusiastic regarding "Sax-O-Phoney Blues," as she states that it is a perfect example of the type of "Blues" song that embodies melody and syncopation. Whenever Miss Smith sings this song at any of her concerts it is accorded an ovation that is responsible for many encores.

DEPARTMENT TO BE ENLARGED

Piano and Talking Machine Department of Spring Holzwarth Co., Alliance, O., to Be Moved to New Building Now Being Erected

ALLIANCE, O., November 5.—Enlargement of the talking machine and piano department of the Spring Holzwarth Co.'s store to twice its present size is announced by J. S. Spring, head of the big department store. A fine line of instruments will be installed.

This concern is now in the midst of a huge building campaign, which embraces the erection of a two-story building to the rear of its present store, which will be devoted to the activities of the store and which will be opened to the public early next Summer.

According to Mr. Spring this department, which now is located on the fourth floor, will be moved into the new building, where better facilities will be available. Additional lines will be taken on. This store handles the Vocalion machine and records, together with a varied line of pianos.

The General Phonograph Mfg. Co.

Model "E" Table Phonograph

The Greatest Value on the Market

IMMEDIATE DELIVERIES IN ANY QUANTITY



New Model "E"

Plays All Makes of Records

Superior Tone Quality

Write for our Proposition

The General Phonograph Mfg. Co., Elyria, Ohio

Tonepen

TRADE MARK

Dealers! Here Is the New, Quick-Selling Guaranteed Tonepen

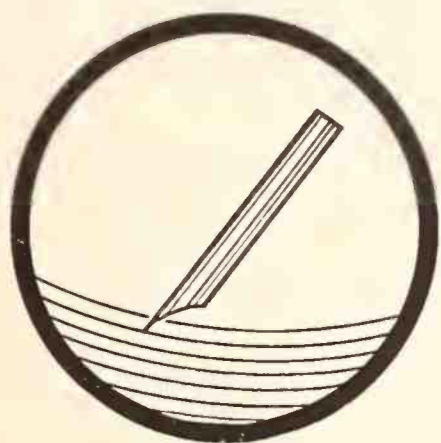

LOUD

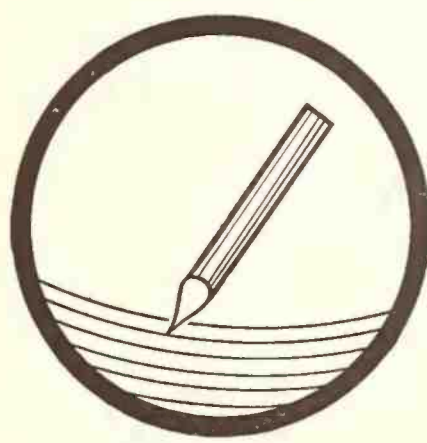

SOFT

The TONEPEN does what no other needle can.

The TONEPEN, unlike ordinary needles, is *scientifically constructed*. It is tubular, like most band instruments, because tubular instruments alone are resonant.

The TONEPEN plays all records. Because it is tubular and light, it quickly responds to sound vibration and does not wear away the record. The TONEPEN gives loud, soft and medium effects. Simply turn the TONEPEN so as to bring more or less

of the point to bear—that is all. No other needle can do these things.

The TONEPEN reduces scratching to practically nothing. Therefore, it brings out of the record all the quality that is in it.

The TONEPEN is good for 80 to 100 records. No other needle lasts so long.

TONEPENS greatly prolong the life of the record.

TONEPENS sell at sight—15 cents for three is the retail price.

Money-Back Guarantee

TONEPENS are *guaranteed*. This means that we will refund the purchase price of a set of TONEPENS if actual use fails to prove our claims.

Write today for our special dealer offer.

Liberal discounts are made to reputable dealers. Stock up now for the Christmas trade.

Send for Free Sample

TONEPEN COMPANY

219 Center Street

New York City

A LIVE COLUMBIA DEALER

Columbia Representative in Montreal Has Built Up a Splendid Business From a Small Beginning by Progressive Sales Methods

MONTREAL, CAN., November 8.—V. Sgroi, one of the most progressive Columbia dealers in Canada, started his business about ten years ago with a capital of \$50 and to-day is carrying stock worth practically \$25,000. He is an exclusive Columbia dealer and, besides handling his main line, Columbia Grafonolas and records, he keeps pianos and all musical instruments.

The one outstanding feature of this sensational rise has been due to good credit arrange-

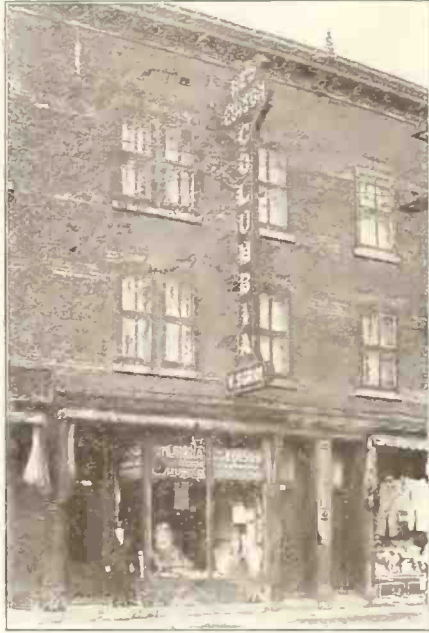

Headquarters of V. Sgroi, Montreal, Canada ment. Mr. Sgroi claims that he has never had any bad credits, owing to his system of refusing small payment customers. Annually, thousands of dollars are spent in advertising in newspapers, theatre programs, motion picture screens and theatre curtains.

On a square near his store there is a public meeting once or twice a week, during which moving pictures are shown. Being progressive, he takes advantage of this opportunity and distributes Columbia fans and, in addition, has his advertisement thrown on the screen during the performance.

Assisting Mr. Sgroi is Mr. Leboeuf, who takes care of all foreign records. While on his honeymoon last June Mr. Sgroi visited the Columbia

VELVET COVERED TURNTABLES

ADD TO THE QUALITY OF MACHINES

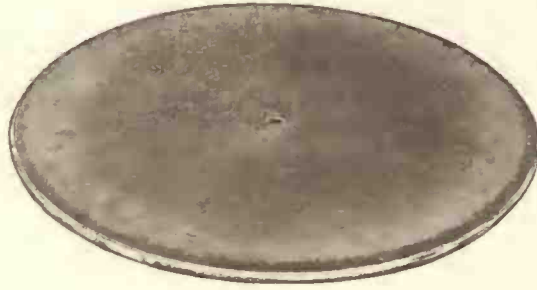

A.W.B.

Boulevard
VELVETS

THE BEST TALKING MACHINES ARE EQUIPPED WITH

A. W. B. BOULEVARD VELVETS

GRAND PRIZE—GOLD MEDAL, ST. LOUIS EXHIBITION

WRITE FOR SAMPLES AND PRICES

A. WIMPFHEIMER & BRO., Inc.
450-460 Fourth Avenue, New York

ESTABLISHED 1845

laboratory and this visit was instrumental in giving Mr. Sgroi a deeper insight into his record business.

AKRON DEALERS LAUNCH CAMPAIGN

Going After Holiday Business in Vigorous Way
—Good Reports From Entire Trade

AKRON, O., November 8.—With the opening of Winter Akron music dealers have launched an intensive campaign for the revival of business, the majority of the trade here feeling that the time has come for marked activity in the sales of talking machines and records, after the last two months, which have been a most backward season as far as actual sales are concerned.

An optimistic tone is given to the conditions in the talking machine market here, due to the general activity that has been apparent since the closing week of October. This is reflected in trade reports at the various rubber factories and

at the Chamber of Commerce, which show that the "turn" has finally come in the business world and that prospects are bright for the Winter.

Miss Helen Baer, head of the talking machine department at the store of the M. O'Neil Co., says that since the removal of the Victrola department to the third floor the record booth arrangements make it possible for the customer to purchase records without any delay. She says there is a better tone in business and is planning an extensive advertising campaign to urge the trade to buy talking machines for Christmas presents on the easy-payment plan.

Business with the Kratz Piano Co., 29 South Howard street, is looking up, according to the proprietor of the store, this week. He says that talking machines have been moving well and records made a gain during October.

Using liberal newspaper space the A. B. Smith Piano Co. the past two weeks has been making every effort to stimulate its talking machine business, and, according to Advertising Manager C. R. Miller, the firm is doing a better business with the Sonora, as well as in records.

Earl B. Poling, whose new Victor store at Mill and Howard streets is one of the most attractive in the city, reports a decided improvement in business, with a call for higher-priced talking machines. "Say It With Music," from Irving Berlin's "Music Box Revue," a late Victor record, was made a leader for November by the initiative of Mr. Poling, who devoted one entire window to a display exploiting its sale.

LOUIS BUEHN CO.'S MODEL SHOP

PHILADELPHIA, PA., November 7.—The Louis Buehn Co. has established a miniature Model Shop of its own at the rear of the first floor of its warerooms, where everything Victor is displayed to good advantage. Dealers are shown how to keep their racks, their counters and decorate their stores. The Buehn Co. has enjoyed a good business all through October and the senior member of the firm believes that the biggest part of the business slump is over. The Buehn Co. is carrying a big stock of records and a large supply of machines, although it is still short on certain of the popular styles. Among the recent visitors was M. F. Elliot, representing the Kline-Eppeheimer Co., of Reading, Pa.

Karl William Pandorf has opened a new music shop at 3949 Spring Grove avenue, Cincinnati, O., and has installed a very substantial stock of all kinds of musical goods.

The KENT MASTER ADAPTER



plays ALL RECORDS at their best
on the
EDISON DISC PHONOGRAPH



Write for particulars concerning this, the best known and largest seller of its kind in the market. Attractive prices and terms will be quoted you.

WE specialize in attachments for Edison and Victor machines; also soundboxes, diamond, sapphire and steel needles. Drawn brass tone arms made to order. Tube and pipe bends of all kinds successfully executed.

F. C. KENT CO. :: Specialty Manufacturers
IRVINGTON, N. J.

whose phonograph accessories "win their way by their play"

Factory
Representative:

LOUIS A. SCHWARZ, Inc.

1265 Broadway
New York City

EDISON SALESMANSHIP SCHOOL

Two Thousand Members of Edison Distributing System to Take Course Which Starts January—Many Invitations for Wm. Maxwell

According to present reports, not less than two thousand members of the Edison distributing system will take the School of Salesmanship course which is to be conducted by Thomas A. Edison, Inc., in some twenty of the largest cities throughout the United States and Canada.

The school is scheduled to start the latter part of January and in the meantime is provoking much interest from other fields. Inquiries are coming now almost daily to the Edison Co. and its officials for data, advice and suggestions regarding how a similar School of Salesmanship can be introduced into other fields. William Maxwell, first vice-president of Thos. A. Edison, Inc., who is looked upon as the founder of the School of Salesmanship idea, as well as a national leader in the art of salesmanship, is being virtually besieged with invitations to speak on the subject of salesmanship before universities, industrial gatherings, chambers of commerce, business men's clubs, advertising clubs, manufacturers' associations, etc.

DEATH OF RICHARD PARR

Former Head of Parr Mfg. Corp. Passes Away in New Jersey

Richard Parr, formerly head of the Parr Mfg. Corp., manufacturer of the "magnetic sound box," died late last week at the home of his brother in New York City. Mr. Parr, besides his late activities in the talking machine industry, was well known in Government circles. For many years he was a member of the staff of the Custom House, New York City, and his activities in behalf of the Treasury Department in unearthing frauds achieved national prominence, particularly in 1907, when he was responsible for the exposure of the sugar trust frauds.

AN EFFECTIVE PUBLICITY STUNT

Wireless Concerts in Crowell-Gifford Store Result in Sales and Free Publicity

PORT ARTHUR, TEX., November 3.—Several clever business-getting schemes which have been put in effect by G. S. Moody, manager of the Victrola department of the Crowell-Gifford store, have resulted in a great deal of free publicity as well as a substantial increase in business. One plan consisted of locating a wireless apparatus and aerial about four blocks from the store and a receiving apparatus in the establishment. A concert was staged every evening in the store, the records, of course, being played where the sending apparatus was located. The store was filled to capacity at each of these concerts and newspapers in surrounding towns within a radius of 200 miles commented on the event.

CUSHMAN WITH REGAL RECORD CO.

Arthur H. Cushman, who is one of the best known record sales executives in the country, has joined the sales division of the Regal Record Co., New York, and is doing splendid work in his new position.

MUSIC TRADE LISTS

19,183 Piano, Phonograph and Music Merchandise Dealers. List shows Piano Dealers, exclusive Phonograph Dealers and Furniture Stores that handle Musical Goods.

- 285 Piano and Player-piano Manufacturers.
- 422 Phonograph Manufacturers.
- 197 Phonograph Cabinet Manufacturers.
- 446 Phonographs, Parts and Supplies (Wholesale and Jobbers.)
- 1,051 Sheet Music Dealers (Wholesale and Retail), large firms only.

Write for prices. R. L. Polk & Co., Room 990, 540 South Clark St., Chicago, Ill.

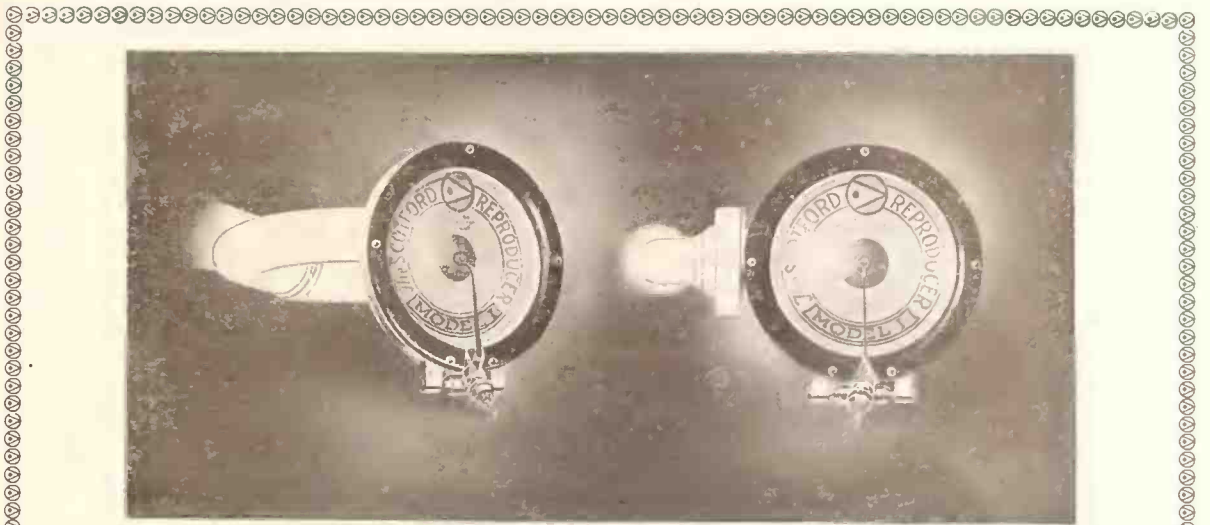

Scottford Model I Reproducer on Victor and Columbia

Plays Only Hill-and-Dale Records, but Plays Them at Their Best
 Scottford Model I Reproducer 1-V for Victor—Sample Prepaid to Dealer
 \$3.85 Nickel; \$4.75 Gold—Retails \$6.00 and \$7.50
 Scottford Model I Reproducer with 1-C Columbia Connection—Prepaid
 to Dealer, Nickel \$4.25; Gold \$5.50—Retails \$6.75 and \$8.75
 Quantity Prices on Application



Superior Specialties for Phonographs
BARNHART BROTHERS & SPINDLER
 Monroe and Throop Streets CHICAGO

TAX RELIEF PLEASES PITTSBURGH

Standard Talking Machine Co. Praised for Efforts—Geo. Schuetz Appointed Manager of Sterling Roll & Record Co.

PITTSBURGH, PA., November 7.—Keen satisfaction was expressed by Pittsburgh talking machine dealers over the action of the United States Senate in repealing the tax of 5 per cent on talking machines and other musical instruments. The Standard Talking Machine Co. did effective work in arousing the Pittsburgh dealers as well as the other clients of the Standard Co. in having them write to their Senators asking them to vote in favor of the tax repeal.

George Schuetz has been assigned to the management of the Pittsburgh offices of the Sterling Roll & Record Co. by F. F. Dawson, president of the company, in a circular issued to the trade. Mr. Schuetz, who is well known in talking machine circles, having been connected with the Indianapolis office of the Columbia Graphophone Co., takes the place here of Ben L. Brown, who is now local manager at the Cincinnati offices of the Sterling Co. The company handles the Okeh records and Cardinal phonographs.

A. A. Buehn, treasurer of the Buehn Phonograph Co., Edison distributor, attended an Edison tone test recital at Washington, Pa., under

the auspices of the G. W. F. Jones Music Co. The Fleming Sisters and Hardy Williamson were the performers and did effective work, and came in for a generous share of the applause from the large and interested audience.

Mr. Buehn stated that all indications pointed to a very satisfactory Fall and Winter season in the Edison line. In the sales contest that is being promoted by the company, which will close on December 31, D. D. Lynn, a salesman in the Edison Shop of W. F. Rossman at Franklin, Pa., is in the lead at present. The winners in each of the districts will be awarded a free scholarship with all expenses paid at the Edison School of Salesmanship.

NEW JERSEY RETAILERS ELECT

S. Semels Elected to Head Victor Dealers' Association for the Year

The Victor Retailers of New Jersey, an organization which has been quite active in recent months, announces that, owing to the resignation of R. H. Veale, its president, and F. M. Palmatier, its treasurer, the following new officers were elected at the last meeting: S. Semels, president; James McGarry, treasurer; Albert Galuchie, vice-president; Clark M. Price, financial secretary; H. A. Glasser, secretary.



If You Sell Musical Instruments You Need This Book

DON'T think of it as just a catalog. Think of it rather as a vast stock of Musical Instruments and Accessories, condensed within the covers of one handy book—a true Buying Guide to Musical Merchandise.

It opens up to you a safe, sure buying source, bringing the markets of the world within your easy reach. It backs you up with all the resources of our comprehensive stocks and ready service—helps you offer your customers a greater selection than ever, without increasing your inventory one cent. That means turn-over. Turn-overs mean profit!

And more than that, it will sell goods for you!

Leave it on the counter for your customers to look over. Perfectly safe! There isn't a wholesale price in the book—retail prices only. And with your name and address in the shield on the cover, it's YOUR catalog and YOUR merchandise that the customer sees.

Write today an your own letter head for these two books. We are glad to send them (FREE, of course) to any Music Dealer

THE FRED GRETSCH MFG. CO.
 Musical Instrument Makers Since 1883
 60 BROADWAY BROOKLYN, N. Y.

And Here's Another Book You Ought to Have

Our catalog isn't complete, though, without another book—our Confidential Trade Price List. There you will find the wholesale cost to you of the merchandise listed in the catalog. And quoting, as it does, the new, low, 1921 Fall prices, it's a mighty interesting book for every retailer of Musical Merchandise. Even if you don't buy from us, you should have this book, if only as a guide in your buying.

DEALERS PUSH "DAILY DOZEN"

New York and Brooklyn Talking Machine Dealers Feature "Health Builder" Records—Noted Dealers Making Extensive Campaigns

Talking machine dealers in New York and Brooklyn are featuring Walter Camp's "Health Builder" records, prepared and distributed by the Health Builders, with headquarters at 334 Fifth avenue, New York. Mr. Camp's exercises, known as the "Daily Dozen," which have been set to specially selected music on five large double-disc records, are finding favor with dealers and the public alike. The records are contained

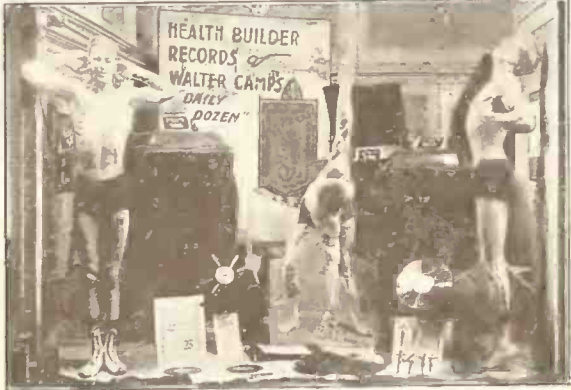

Davega's Health Builders Window

in an album, together with twelve charts, showing the movement to make at each command. The charts contain more than sixty photographs, illustrating each movement, and a booklet of instruction.

Robert B. Wheelan, president of the company, announces that in the metropolitan district alone some of the best-known retailers are finding this course very popular with their customers, among them being the five stores operated by the S. B. Davega Co., Wanamaker's and Bamberger's of Newark, N. J.

In Wanamaker's the various employes of the talking machine department have gone through the exercises described in the course each morning before the opening of the store and it has

been found that practically the entire department is there promptly at 8.45 in order to secure for themselves the benefits and pleasures derived from these exercises.

A similar condition was experienced recently in the large department store of Lord & Taylor, where a representative of Health Builders, Inc., presented the exercises to 500 employes of that large organization. The exercises were given to classes of 100 at a time.

All five stores of the S. B. Davega Co. have featured the Health Builders' course in an admirable way. Advertising space in the metropolitan dailies has been devoted to this subject and window displays and store demonstrations have done much to bring the course to the attention of the large number of people served by these stores. In the various window displays, one of which is depicted herewith, large cut-outs of men going through the exercises have been used which are almost lifelike. The S. B. Davega Co. has also sent out, through the mailing list, thousands of circulars on the subject and has offered free sample records.

W. H. Bishop, manager of the talking machine department of Frederick Loeser & Co.'s store in Brooklyn, is enthusiastic over the "Daily Dozen" and is preparing to institute a campaign of advertising and circularizing to bring them to the attention of Loeser customers.

REPAIRS

We have a specially equipped repair shop and efficient mechanics to make all kinds of repairs on talking machines of every type. When sending repair work parcel post it is most important that a label be attached, with full instructions concerning same, and, unless special work is required, it will be returned within 48 hours after receipt of same.

"WE GUARANTEE SATISFACTION."

Send us your repair work by parcel post or express and get results.

Yours for service, THE PERIOD PHONOGRAPH SHOP

303 WEST 127th STREET
NEW YORK CITY

P.S.—We also have on hand Parts and Supplies for All Makes of Machines.

R. B. Wheelan reports that this course is now being sold in every part of the country and also that large numbers of school teachers have bought this course not only for their personal use, but for use in the classroom as well.

MME. GALLI-CURCI SCORES

Mme. Galli-Curci, the well-known prima donna, who is a member of both the Chicago and Metropolitan Opera Co., and who makes records exclusively for the Victor Talking Machine Co., made her first appearance of the present concert season at Chicago on Sunday afternoon, October 23, at the Auditorium. This event is of special interest when one recalls that it was on this same stage, five years ago, that Galli-Curci made her famous debut, receiving one of the most spontaneous, sensational ovations of musical history.

The great diva has since made from twelve to fifteen appearances in Chicago each year, to houses sold out in advance. This year, like in previous years, the advance sale consumed the entire tickets on sale and packed the house to such a capacity that even the huge stage was entirely occupied, six hundred people being seated on it. Mme. Galli-Curci's concert appearances are under the management of Evans & Salter, Fifth avenue, New York City.

POLYPHON
Imported



RECORDS
Imported

These German Records in Greatest Demand!

Extensively Advertised in Leading German Newspapers

Dealers--Supply This Demand!

Grasp this opportunity NOW—for greater Profits—Certain exclusive territories still available.



These records comprise the Catalogs of Germany's leading phonograph factories—also complete catalogs of Turk, Greek, Arab, Syrian and Spanish records.



ARION RECORD IMPORT

1501 GERMANTOWN AVENUE

PHILADELPHIA, PA.

Sole United States Agents for Polyphone Werke Akt. Ges., Berlin

"DA-LITE"

ELECTRIC DISPLAY SERVICE

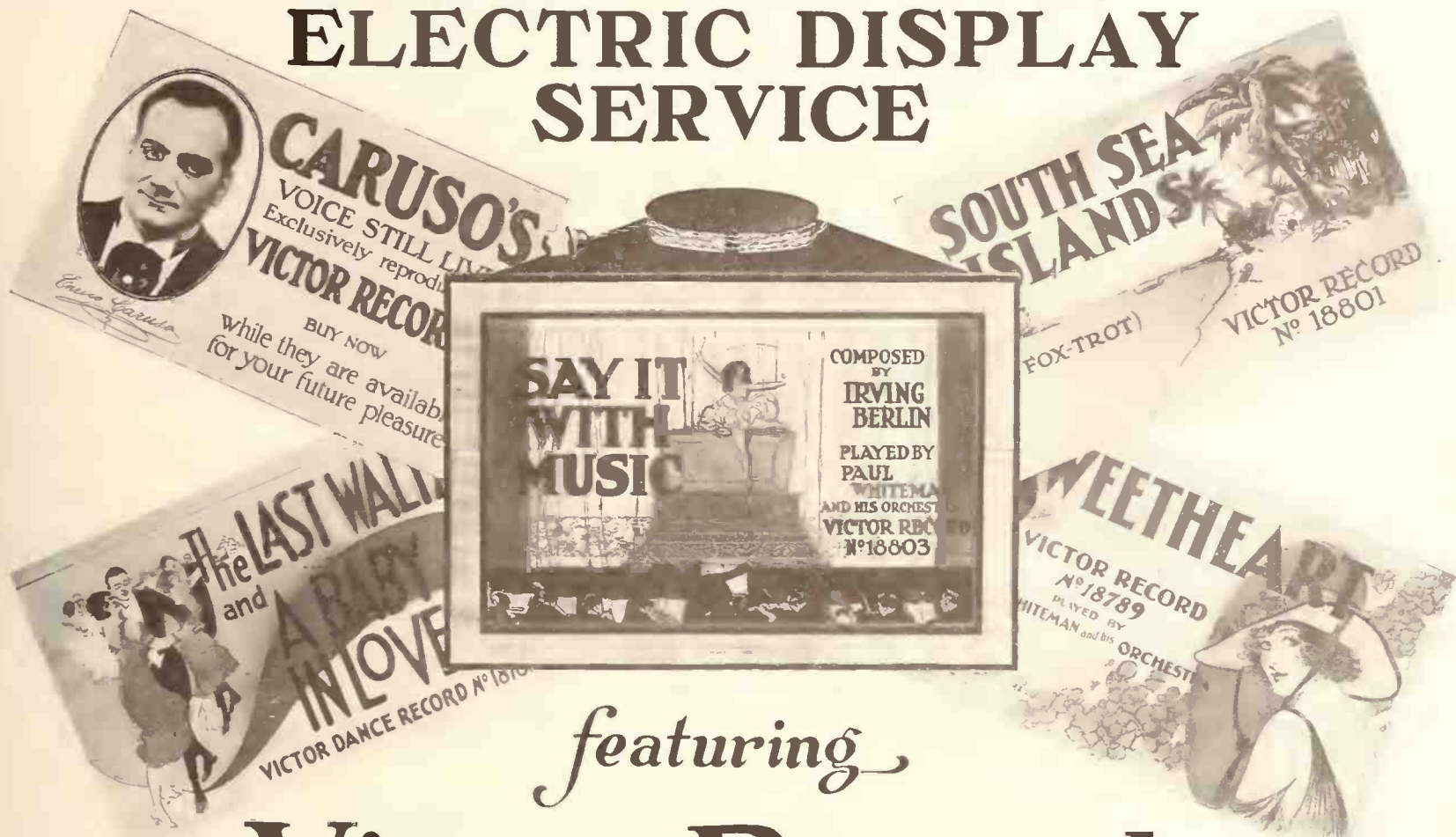

featuring

Victor Records

THIS SERVICE WAS STARTED SEPTEMBER FIRST WITH THE CO-OPERATION OF THE WHOLESALE VICTOR DISTRIBUTORS

A LARGE NUMBER OF DEALERS HAVE ALREADY PROFITED BY ITS USE IN AN INCREASED SALE OF RECORDS. THE REASON IT SELLS RECORDS IS SIMPLE AND LOGICAL:—There is a wave of colored light passing over the face of the display. The MOTION ATTRACTS the EYE. The appeal of the novel, artistic front is sufficient to register on the mind the suggestion to purchase, and it does this at the opportune time when the records are immediately available, for the display is intended for use in the daytime and attracts just as much attention during business hours as at night. Many records are purchased on the impulse of the moment; for this reason you make DIRECT SALES that you would not otherwise obtain.

The display is only 13½x19½, but attracts more attention than an ordinary sign twice its size. It does not occupy any window space, as its proper place is in the rear of the window on a pedestal above the goods on display. It can be kept in constant use, as there are four new fronts each month. It does not grow monotonous; on the contrary, your customers get in the habit of glancing at it to find out WHAT'S NEW IN RECORDS.

WE FURNISH YOU THE ELECTRIC DISPLAY WITHOUT CHARGE

THE SERVICE CONSISTS OF FOUR ARTISTIC, HAND-COLORED PANELS EACH MONTH AT THE VERY LOW PRICE OF \$6.00 FOR THE SET. THE TOTAL COST FOR BOTH THE SERVICE AND ELECTRICITY (using the display 12 hours a day) IS 30 CENTS OR LESS THAN THE PROFIT ON ONE 85-CENT RECORD.

THE DISPLAY MUST BE SEEN TO BE APPRECIATED, AND WE SUGGEST THAT YOU ORDER NOW FOR SERVICE STARTING DECEMBER FIRST AND HAVE THE DISPLAY FOR USE DURING THE HOLIDAY SEASON.

SEND YOUR ORDER THROUGH YOUR VICTOR JOBBER AND WE WILL FORWARD THE OUTFIT AT ONCE, AND IF IT IS NOT ENTIRELY UP TO YOUR EXPECTATIONS YOU CAN RETURN BY EXPRESS AT OUR EXPENSE.

"DA-LITE" ELECTRIC DISPLAY COMPANY

114 NORTH ERIE STREET

TOLEDO, OHIO

TONEPEN NEEDLES FOR RADIO WORK

Tonepen Co. Pleased With Reception Accorded This Product—Arranges Attractive Window and Counter Display Cards—Output Is Increasing and Company Is Enthusiastic

The Tonepen Co., New York manufacturer of the new Tonepen needle, which has now been distributed to the trade for some time, reports that talking machine dealers are meeting with much success in retailing this needle and that phonograph owners are much pleased with the results obtained.

The officials of the company are very much pleased with the reception the needle has been accorded so far from dealers everywhere. Recently the company received a very flattering letter from the American Radio League, Inc., which, after experiments, states that "the Tonepen needle produced a clearer and better tone than many others which were tried out." As the sending of phonograph music by radio requires a very clear and more intensive tone, the officials

of the Tonepen Co. are very much pleased at the results the Tonepen has achieved in these experiments. The Radio League is enthusiastic to the extent that it is recommending the use of the Tonepen to its several thousand members in all parts of the country.

Dealers who handle the Tonepen needles are being furnished with very attractive counter and window display cards by the company that make a very striking sales appeal to the talking machine owner. One of these is in the form of a counter display stand done in black and red, showing a cut of the needle in playing position on the record with an original and specially constructed compartment where a stock of needles can be kept. This compartment is so made that it can be opened and closed by the sales person and still be out of reach and sight of the customer.

Sales of Tonepen needles are every day showing a gratifying increase and officials of the company are very enthusiastic about its future, as all indications point to a country-wide distribution.

In last month's World it was incorrectly stated that the Tonepen needle was originally invented by William Dubilier instead of one of his associates, William S. Mountford, who holds the patents for same. Mr. Mountford conducted his experiments at the Center street factory and Mr. Dubilier became interested through the fact that this new needle was the product of engineering and scientific principles of sound-producing and high frequency oscillations and vibrations, and, with Mr. Mountford, perfected the needle to its present form.

FRED GRETSCH GOES TO EUROPE

Will Visit Musical Instrument Centers on the Continent During Six Weeks' Stay

Fred Gretsch, president of the Fred Gretsch Mfg. Co., manufacturers and wholesalers of musical merchandise, 90 Broadway, Brooklyn, N. Y., sailed last month on the S. S. "Aquitania" for London. He will be gone six weeks and expects to visit the principal musical instrument centers of Europe in the interests of his firm. Mr. Gretsch, who is also president of the National Musical Merchandise Association, will make a careful study of the European situation, especially in its bearing to the proposed American Valuation Clause of the tariff bill now before Congress.

EDISON SLOGAN CONTESTANTS

ORANGE, N. J., November 9.—It has been impossible as yet to announce the prize-winners of the national contest which has been carried on by Thomas A. Edison, Inc., for a slogan for the New Edison. In all, about three-quarters of a million suggestions were entered in this contest, and this number is so large that in order to do justice to each individual entry it has been necessary to take a longer time than was expected before the slogan can be selected.

ANALYZING THE RETAIL FIELD

Ernst & Ernst, the well-known specialists in organization and systematization work, are now sending out a large number of detailed questionnaires to retailers in various fields, and upon the results of these questionnaires this company will base a report upon the expenses of conducting a retail store along such lines as the correct number of sales people to employ, proper salaries for selling and non-selling members of the organization, the ratio between the number of selling employes and non-selling employes, the percentage of costs, the credit department, and the volumes of departments as compared with the whole volume.

Story & Clark have purchased the Victor stock of the Musical Record Co., of Los Angeles, Cal., and are now Victor dealers in their new building on Broadway, between Eighth and Ninth streets.

SONG AND GIFT SHOP OPENS

Jerome H. Remick & Co. Open Fine New Music Establishment in Chicago—Handle Columbia Machines and Records Exclusively

CHICAGO, ILL., November 7.—The Song and Gift Shop, 240 South State street, this city, is the name of the latest addition to local Grafonola shops here. The establishment, which was opened by Jerome H. Remick & Co., music publishers, is splendidly decorated and is the equal in appearance of any store in that section of the city.

A large crowd, including representatives from talking machine concerns, music publishers and music houses, enjoyed an excellent program by Columbia artists. Carl West, formerly in charge of the company's store in Toronto, Canada, has been placed in charge of the local establishment.

Why not get the business of the thousands before the millions are approached.

SPECIAL!



Mother Goose Book

A beautifully illustrated book with two unbreakable six-inch records which the kiddies will love and cannot destroy. Every child will want to play them over and over again.



Santa Claus Book

LIST PRICE 50c

SPECIAL DEALER'S DISCOUNT

Let us help you make your accessories business build up big profits for you this Fall.

Write for our new 100 page catalogue

THE CABINET and ACCESSORIES COMPANY

Otto Goldsmith, Pres.

145 E. 34th St. NEW YORK

Merchandise For Your HOLIDAY TRADE



DURRO

The Choice of Artists Everywhere

Phonograph Dealers:—

Make your place the center for all musical merchandise sold in your neighborhood.

Extend your lines to include

DURRO VIOLINS, BOWS, STRINGS, ETC.

LESTER & SALANTI ACCORDEONS.

ABBOTT BAND INSTRUMENTS.

ABBOTT SAXOPHONES.

DUSS BAND HARMONICAS.

S. S. STEWART (BANJOS, GUITARS, UKULELES, MANDOLINS, ETC.)

And our popular lines of accessories.

They are most celebrated brand.

They are quick sellers and yield liberal profits.

They mean no addition to overhead.

They make fine displays and draw repeating customers to your store.

Give your trade what they want.

WHY WAIT

And let business go by your place?

Write to-day for complete No. 112 catalog



Buegeleisen & Jacobson

5-7-9 Union Square

New York



These Trade Marks are YOUR PROTECTION. We do not Copy or Infringe, but Invent and Originate.

Always YOUR GUARANTEE OF QUALITY, PRICE AND SATISFACTION.

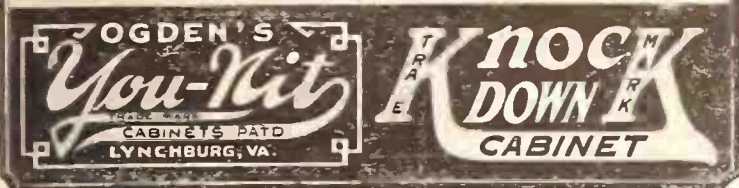

OGDEN'S ORIGINAL "STANDS"

Announcing New Model No. 50 K. D.

For New Model Victrola No. 50 Portable which makes this "Vacation" Model an All-Year-Round Proposition and a Big Holiday Seller.

Dealer's Price \$6.50

Retail Price . 10.00

Finishes Mahogany Quar. Oak (3 Finishes) **TO MATCH** The No. 50 Victrola

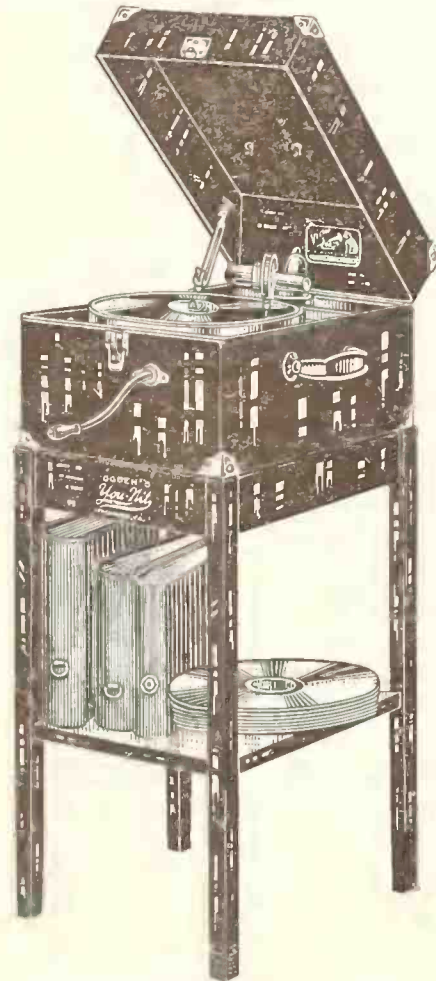

Victrola and Stand ready for business

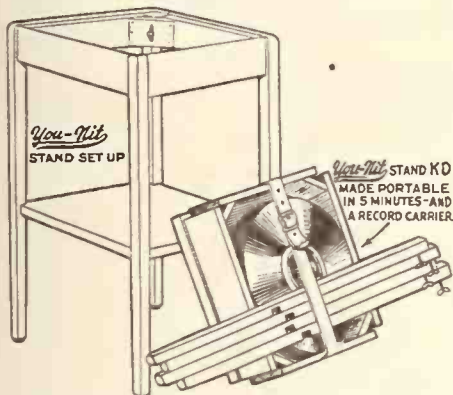

No. 50 "Set Up" and "Knock Down"

Wire or write for Samples today and list of Jobbers who had Stock shipments Nov. 5th.

Ships K. D.--Weight, 12 lbs. each individual Carton. Delivered Freight Paid in 1-Dozen Lots.

Ogden's You-Nit Stands Display the No. 50 so it "Sells" and makes a Home Outfit for Victrola and Records. It is also a K. D. Portable Stand and Record Carrier for the Camp. Correctly Designed in Harmony with, and matches, the High Quality Victrola in Material and Finish. Genuine Select Mahogany and Quar. Oak and is *Unconditionally Guaranteed* to each Purchaser.

Service Tables and Display Stands

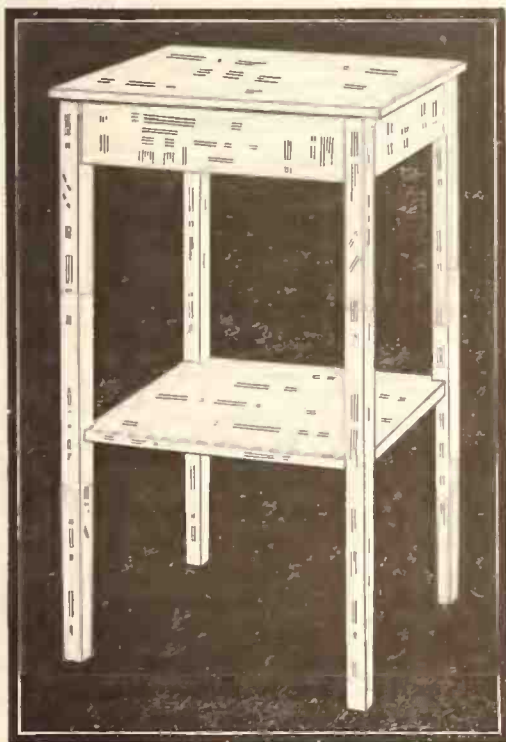

SERVICE TABLES

Enamels, Oak & Mahogany Finishes \$4.75

DISPLAY STANDS

Solid Quar. Oak	Net \$3.60	Retails \$5.00 or \$6.00
Mahogany Finish	Net \$3.85	Retails \$6.00 or \$7.00
Solid Mahogany	Net \$4.25	Retails \$7.00 or \$8.00
Utility Detachable Top	.90	

Mail them back the minute you see them if you are not pleased and the postage will be refunded. This is our GUARANTEE. Low price—High quality.

Every Booth needs a Table as a Service Convenience for the Sale and Selection of Records and Displaying Catalogues, etc., etc.

Display Stands Sell with the Small Machine at a profit to the Dealer and Satisfaction to the Customer. They "Boost" your Record Sales because they create new customers.

Packed 2 in a Mailing Case (Knock Down), delivered by frt., ex. or P.P. at small cost. Order samples direct and we will charge to your Jobber.

Knock Down Display Stands

Are Patented

Prices Reduced

To Pre-war Basis
(Effective November 20)

Patented Record Cabinets designed for Efficiency and Service are Guaranteed to fit your requirements.

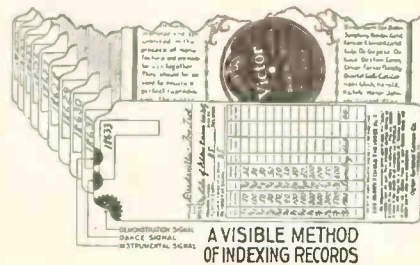

VISIBLE TAB INDEXES extend in front of the Record with all numbers Visible and is an immediate Reference to every Record in Stock. They are adapted to Reference Labels or hand lettering.

10" and 12" Sizes, \$14.00 per M.

Ogden Sectional Cabinet Co.

INCORPORATED
LYNCHBURG, VA.



Frank Crumit, now playing in *Tangerine*, simply "stops the show" when he sings "Sweet Lady," which he wrote. It's this exclusive Columbia star's newest hit. "You're Just the Type for a Bungalow" is the other sure-selling song on A-3475.

Columbia Graphophone Co.
NEW YORK

THE BUSINESS PENDULUM SWINGS UPWARD IN PORTLAND

Dealers Ordering Their Requirements Confident of a Good Volume of Holiday Business—Trade as a Whole in Optimistic Mood—Review of the Situation Shows Much Activity

PORTLAND, ORE., November 4.—There is no doubt that general financial conditions are improving and a better feeling prevails that the business pendulum has now started to swing upward and Portland music dealers feel that they are definitely headed toward a healthy revival of business.

With this better feeling prevailing merchants are ordering their actual requirements with more confidence and the hand-to-mouth system of buying has ceased.

"Five Days of Free Music," as advertised extensively in the Portland newspapers by the Columbia Graphophone Co., is a huge success and all the dealers co-operating with the company report a big increase in their sales since the beginning of the extensive advertising campaign. Wm. H. Lawton, Northwest general manager, spent some time in Portland working up the interest of the various Columbia dealers, and Robert Porter, assistant sales manager, of New York, spent a week with him. Mr. Porter says all dealers in Oregon, Washington, Idaho, Montana and California that he visited were most enthusiastic over the drive and dealers all over the country are reporting increased sales.

E. B. Hyatt, of the Hyatt Machine Co., reports business exceptionally good for October,

with all of the fifteen demonstration rooms kept busy most of the time.

Mr. Hyatt entertained his whole force at the recent dinner given by the Oregon Music Dealers' Association. A shipment of thirty-four Victrolas of the cabinet type has just been received by the company and these machines are being sold almost as fast as they can be unpacked.

W. A. Bartlett, of the Hyatt Co., says he sold two Edison Chippendales the day after the Edison tone-test concert, which was under the auspices of the Reed-French Piano Co.

The monthly meeting of the Oregon Music Dealers' Association was held October 18 at the Hotel Imperial. Fifty-eight members were present and after dinner a most interesting and instructive talk was given on "Sales and Service" by George Wessells. Mr. Wessells is widely known for his practical talks along trade lines and was for several years instructor in the sales department of the Los Angeles public schools.

Clyde Freeman, manager of the Remick Song and Gift Shop, which is also exclusive Columbia dealer, reports the sale of more machines during October than for the past four previous months combined.

Paul B. Norris, manager of the Wiley B. Allen talking machine department, reports business better the past month than for many previous

months. A Victrola was purchased out of the nurses' fund by the sisters of the Vancouver Hospital, and a big order of records accompanied the instruments to the hospital. The sisters declare music the very best remedy for both patients and nurses and told Mr. Norris that the Victrola will fill a long-felt want.

Elmer Hunt, wholesale manager of Sherman, Clay & Co., reports a big increase of business all over his district. At the present time he is busily engaged arranging his stock in his commodious new quarters on Glisen street.

The Foley-Maegly Music Co. is retiring from business and is having a removal sale, reducing all goods with the exception of Victrolas and Victor records. Mr. Foley has been in business since 1918. An extension of the lease of the building occupied by the Foley-Maegly Co. was refused, as the building is to be wrecked. Suitable locations are hard to find, so Mr. Foley decided to retire and will go into the wholesale piano business with M. C. Koester, Western representative of the Smith, Barnes & Strohber Piano Co.

Carl Jones, of the Columbia Co., reports the installing of three new agencies—the Sabin Drug Co., of Grants Pass, Ore.; the East Side Pharmacy, of Ashland, Ore., and the Washougal Pharmacy, of Washougal, Wash.

The appearance of Theo Karle, American tenor, in concert at the public auditorium in October occasioned a great deal of advertising by Brunswick record dealers, for which Mr. Karle sings exclusively. Mr. Davis, of the wholesale department of the Brunswick-Balke-Collender Co., called with Mr. Karle on several of the dealers during the latter's stay in Portland. "Ah! Moon of My Delight" was delightfully sung by Mr. Karle at the concert and many calls for this and other records have been requested by admirers of Mr. Karle's voice.

Cyrena Van Gordon, exclusive Columbia artist, who appeared in a concert at the Municipal Auditorium October 24, proved very popular and the large audience which heard her demanded many encores. All Columbia record shops report a good demand for her records since her appearance.

A. M. Wrayton, sales manager of the phonograph department of the Bush & Lane Piano Co., welcomed with open arms the carload of Bush & Lane phonographs which arrived the first of the month.

Increased business in the Columbia Grafonola department of the McDougall Music Co.'s store has necessitated additional help and Miss Vivian Dunkle has been added to the staff to assist C. H. Williams, the manager.

Victrolas for ocean voyages are gaining in favor and no ship that leaves the port of Portland considers itself complete without a Victrola and all the latest records. F. D. Addis, manager of the Victrola department of the Sherman, Clay & Co. store, installed a Victrola IX on the Dutch steamer "Tjikembang," with Victor records ranging from Red Seal to the jazziest of jazz. C. L. Neilson, who recently joined force with Sherman, Clay & Co., has installed

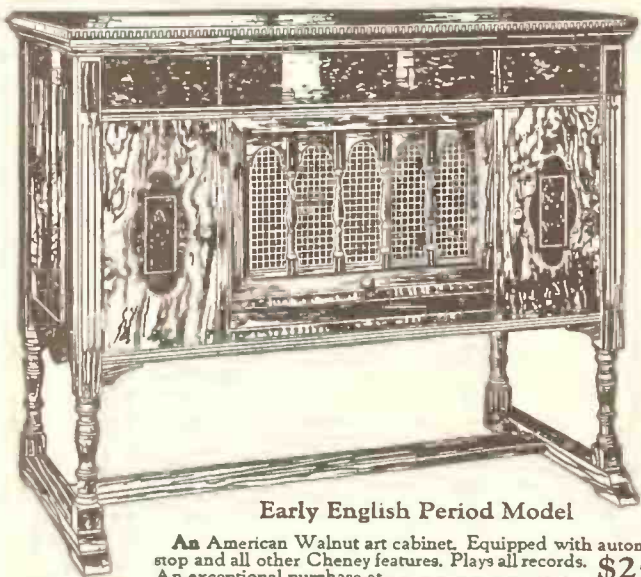

Early English Period Model

An American Walnut art cabinet. Equipped with automatic stop and all other Cheney features. Plays all records. \$250
An exceptional purchase at

We offer the maximum of service to Cheney dealers in the following territory—

- Connecticut (Western)
- New York (Metropolitan District)
- New Jersey
- Pennsylvania (Eastern)
- Delaware
- Maryland (Eastern)
- Dist. of Columbia

We have an interesting proposition. Write for details to-day

CHENEY SALES CORPORATION

G. DUNBAR SHEWELL, President

Philadelphia Office
1105 Chestnut Street

New York Office
1107 Broadway

the same model on the ship "Portsaid Maru," bound for Japan.

The Jennings furniture store is closing out its general stock of phonographs and will be an exclusive Columbia dealer.

Soules Bros., of Tenth street, who carry the Brunswick, Actuelle, Starr, Valuphone and Burnham phonographs, report a large increase in sales of machines over previous months and expect a lively Winter trade.

C. A. Alphonse, of the Hyatt Talking Machine Co., is a hard worker and is always being picked to serve on committees. During the past week he was appointed to serve on the band committee in connection with Portland's Music Week and has been named chairman of the entertainment committee of the Oregon Music Dealers' Association.

Jack Dundore, son of J. H. Dundore, of Sherman, Clay & Co., who was in the Victrola department of the local store, has been transferred to the Tacoma store, to take the management of the Victrola department.

C. L. Neilson, formerly of the John Elliott Clarke Music Co., of Salt Lake City, is a new addition to the Victrola department of the Sherman, Clay store.

The Red Seal record that is proving most popular at the present time is "Finlandia," played by the Philadelphia Symphony Orchestra, says Leita Hayes, manager of the G. F. Johnson Piano Co.'s record department. Two songs that have also taken well are "The Want of You," by Edward Johnson, and the "Mother Goose Songs," by Mme. Homer.

Between three and four thousand people attended the three performances of the Tippy Toe Bubble Book party, given at the auditorium of the Meier & Frank store, October 22. The Mother Goose pantomime and games were given in costume by seventeen Portland tots, with Miss Mary Mahoney as Mother Goose, and the production was put on by Beulah H. Grace, of New York City, who is traveling over the entire country in the interest of the Bubble Book for the H. C. Sherwin Co. Miss Grace has been on the road since last February and has met with wonderful success everywhere. The performance was most artistic, the records, "Jennia Jones," "Farmer in the Dell," "Lazy Mary," "Mulberry Bush," "Oats, Peas, Beans" and "London Bridge" being played on a phonograph and sung and acted out by the children. The Meier & Frank Co. has booked only two performances, but the production proved so popular that an hour before the afternoon performance was scheduled to start the auditorium and all available space was so crowded that they decided to start early and give two shows.

Miss Helen Clarke, contralto; Joseph Phillips, baritone, and Thomas George, pianist, appeared in an Edison tone-test concert in the auditorium of the White Temple Tuesday evening, October 25, under the auspices of the Reed-French Piano Co. Music lovers of Portland turned out en masse to hear these artists.

J. J. Collins, of the Reed-French Piano Co., reports a marked increase of interest in the Edison machine since the recital.

WE DO RECORDING

Why not record and sell under your own label? We engage talent and make records for regular releases for commercial purposes, musicians, correspondence schools, orchestras, clubs, or private individuals. Recording for any purpose. Send for rates.

Phonograph Recording Co.

260 West 42nd Street
New York City

Phone: Bryant 6389

TWO IMPORTANT APPOINTMENTS

ORANGE, N. J., November 5.—John Stapleton, a man with considerable experience in the retail end of the phonograph industry, has recently been made manager of the Edison Shop in Fifth avenue, New York City.

Samuel Halsey, who has had an extensive experience in various divisions of the Edison industry, has been placed in charge of the wholesale business conducted by the Phonograph Corporation of Manhattan. The latter is at present making his headquarters in Orange, N. J.

MAX WILLINGER IN CHICAGO

Max Willinger, president of the New York Album & Card Co., New York City and Chicago, manufacturers of "Nyacco" record albums, left for a six weeks' stay at the Chicago offices of the company. Both the Chicago and New York offices are vying with each other in the volume of orders they are securing and it is keeping Mr. Willinger busy dividing his time between the two offices.

ORCHESTRAS RECORD FOR EDISON

Two of the dance orchestras to recently record for Thos. A. Edison, Inc., are the Club de Vingt Orchestra and Conrad's Orchestra. The former is well known to New Yorkers and has won great popularity both with those who attend the Club de Vingt and the Hotel Vanderbilt. Conrad's Orchestra enjoys a similar popularity with the fashionable Newport set at the Casino in that city. Several new records have recently been released by both of these orchestras.

CHANGES AT THE AEOLIAN PLANT

Hugh L. Thompson, who has been in charge of the Aeolian Co.'s record plant at Meriden, Conn., has been promoted to the position of research expert in connection with records. Edwin W. Carruth, superintendent of the local factory, will also supervise the record plant.

Persistence and the gift of gab may sell some goods, but courtesy makes steady customers.



The new and better Phonograph

Model 8. Mahogany or Walnut
Top 36" x 21". Height, 34½"

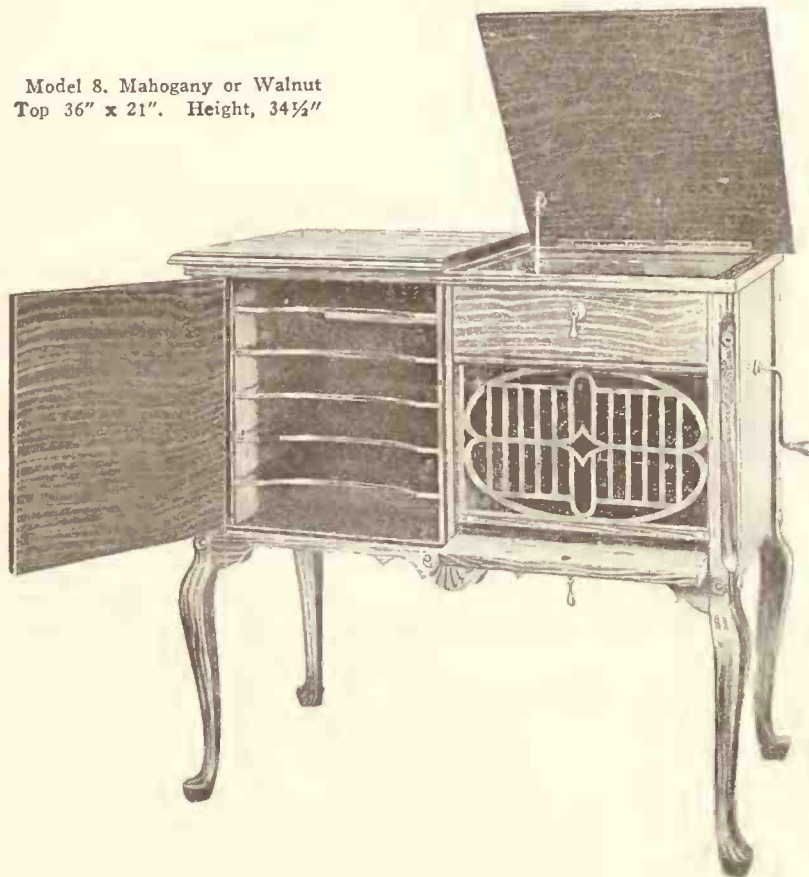

List Price - - - \$125
Costs the Dealer - - - Ask us!

This is Model 8—the first of the Strand line to be announced. It is the product of the third largest phonograph cabinet plant in the United States, with twelve years of high-grade phonograph designing and building behind it. Let us send you photographs and an outline of just what we offer the dealer in quality of product, low list, fat discount, and trouble-proof packing and shipping.

"IT'S THE DEALER'S TURN NOW."

The man who does the selling is entitled to a real profit.

"Better merchandise, lower list, and fatter discounts."

MANUFACTURERS PHONOGRAPH COMPANY, Inc.

95 MADISON AVE., N. Y.

GEORGE W. LYLE, PRESIDENT

EXCELLENT NEW BOOK ON SELLING

"The Science and Art of Selling," by James S. Knox, Analyzes the Basic Principles of Salesmanship in a Manner That Is Practical and Interesting—A Worth-while Treatise

One of the best books published this year on salesmanship is "The Science and Art of Selling," by James Samuel Knox, A.M., LL.D. It is published by the Knox Business Book Co., Cleveland, O.

This book, in a most conscientious manner, covers most completely the subject of its title. Divided into five parts, it discusses: (1) Fundamental Factors in Business; (2) The Basic Principles of Salesmanship; (3) Retail Salesmanship; (4) Efficient and Inefficient Selling Methods, and (5) Specialty Salesmanship.

In the preface the author touches the keynote of his most estimable work. Quoting from the introduction, "Every bit of unnecessary waste must be eliminated from the handling of goods. This cannot be done through ignorance, which means waste and expense that must be paid by the customer. It must be accomplished by a careful technical training of every individual who has anything to do with the handling of the merchandise—traveling salesmen, clerks and merchants alike. Every untrained salesman, merchant or clerk adds to the high cost of living, which must be paid by the public."

Through the volume the author explains, with extreme simplicity, the science of selling, and thereby points the way to eliminating unnecessary waste in the handling of merchandise and thereby reducing the cost to the ultimate consumer.

In the first part, called "The Fundamental Factors in Business," the economics of distribution, trade channels, store management, bookkeeping, psychology of business, human instinct and the senses are discussed.

The second division, "Basic Principles of Salesmanship," to which the greater part of the book is devoted, covers every angle of the salesman's individual problem from the approach to the closing of a deal.

The third part, dealing with retail salesmanship, gives valuable information and suggestions to salespeople, cites several model selling talks, and discusses retail selling methods, store training and managerial problems.

Then comes a discussion on efficient and inefficient selling methods, which is carried out in a most illuminating way and which proves its

Ship O'Dreams

A New Song Gem in the Famous "SAM FOX LIBRARY EDITION"

On the recital and concert programs of many well-known artists.

Recorded on

VICTOR RECORD No. 45254

Just Released

Sung by

MERLE ALCOCK

Sam Fox Pub. Co.
CLEVELAND NEW YORK



points with several well-known examples and finally a treatise on the specialty salesman.

Throughout the work there appear a great number of charts and illustrations which help the reader to more quickly and accurately visualize the procedure of development, which the author explains.

The book throughout is arranged most conveniently. Divided into parts, as it is, and then into chapters, and with bold-faced captions used throughout the pages, the work is admirably suited for a reference book on selling. The pleasing style of writing which the author employs, together with the many interesting examples which he cites, takes the work out of the cut-and-dried text-book class and makes it both instructive and entertaining to read.

The volume should be most valuable to sales managers and salesmen in the music industry, as its contents pertain so closely to the problems of the sales force of the music store.

RHINES SHOP OPENS IN CANTON

CANTON, O., November 3.—A branch store of the Massillon, O., Rhines Shop, exclusive Edison dealer, was opened here last week at Third street and Cleveland avenue. The new establishment contains five sound-proof demonstration booths. H. M. Rutledge, formerly of the Massillon store, has been made manager of the local branch. A complete line of Edison phonographs and records is handled and an Edison turntable has been installed.

OKEH DISPLAY FOR DECEMBER

The Okeh window display for December prepared by the dealer service division of the General Phonograph Corporation is artistic to a degree and typifies the Christmas spirit. During the past few weeks quite a number of Okeh jobbers and dealers have visited the company's headquarters in New York, and they have



Interesting Window Display for Holiday Month evinced the keenest interest in the December display, stating that it will undoubtedly act as a marked stimulant to the sale of Okeh records during the Christmas season.

A. H. CURRY CONVALESCING

ORANGE, N. J., November 10.—A. H. Curry, recently elected vice-president of Thomas A. Edison, Inc., and in charge of phonograph merchandising, returned to Dallas a few weeks ago for the purpose of looking over his Edison wholesale and retail interests in Texas. While there he contracted appendicitis and was operated on in Dallas. The operation proved very successful and, although Mr. Curry's condition was very serious at one time, he is rapidly regaining his old-time strength and vigor. He is expected back in Orange by the first of December.

A BUSY GRANBY FACTORY

NEWPORT NEWS, VA., November 7.—The Newport News Press in a recent article refers to the Granby factory in this city as being the only factory in the locality which has been running continuously full time and overtime during the last few years. There follows a detailed description of the addition to the Granby factory which will shortly be constructed and which was announced some months ago. This new addition, besides being an excellent example of a modern factory, will add considerably to the already large plant in this city.

EMERY'S MUSIC STORE OPENS

Emery's Music Store is the name of a new Victor establishment which was formally opened at Gardner, Mass., recently. A complete line of Victor products is handled in addition to pianos and sheet music. Sound-proof demonstration booths and other conveniences have been constructed for the comfort of patrons.

JOBBER—ATTENTION!

Announcing to the trade that we are now making arrangements to allot *exclusive territories* in all sections of the country to responsible houses for an *internationally known foreign record*, for which there already exists a great demand in this country.

The catalog is a complete one and comprises all languages, including *German, Polish, Bohemian, Yiddish, Hebrew, Scandinavian, Irish, French and many others.*

Concerns interested in the handling of the leading foreign records are invited to communicate with us immediately for further particulars.

Hegeman-Stewart Corporation

338 Washington Street

New York, N. Y.

OGDEN KNOCK-DOWN STANDS

Demand for These Specialties Growing Steadily Throughout the Country

LYNCHBURG, VA., November 9.—The Ogden Sectional Cabinet Co., of this city, reports that its line of knock-down stands which was originally offered to the trade during the Summer months is meeting with much approval and demand. In addition to their use as a suitable stand for table models of talking machines, they are serving an excellent purpose as service tables and display stands for the talking machine wareroom and booth, for the sale and selection of records and displaying catalogs, etc. They are equipped, if desired, with a utility detachable top and come in a variety of finishes, enameled, oak and mahogany.

The Ogden Sectional Cabinet Co. has a large woodworking plant in this city and has built up

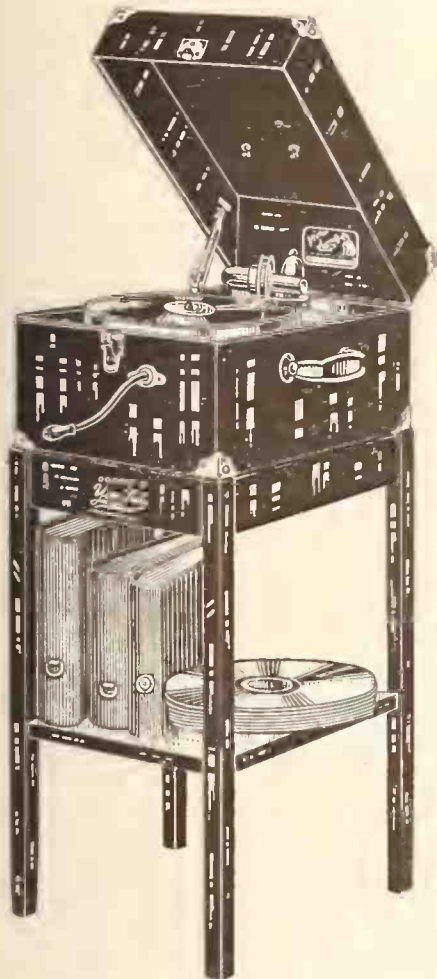

New Model No. 50 K. D.

an excellent business on the sectional construction idea. The Ogden sectional record cabinet for the dealer's use is known from coast to coast and the service tables and display stands which it is now producing in addition to its regular lines are made in the same large plant.

J. B. Ogden, president of the company, reports that business has improved greatly and that, judging from the large demand for its products, 1922 will see a continuance of these good conditions.

EXPRESSION VS. IMPRESSION

Expression must equal impression. If you study you must also create, write, teach, give out. Otherwise you will become a plaster-of-Paris cat or a brass monkey. If great joy has come to you, pass it along, and thus do you double it. You are the steward of any gift the gods have given you, and you answer for its use with your life. Do not obstruct the divine current. Use your knowledge and use it quickly, or it will disintegrate and putrefy.—Elbert Hubbard.

BUSINESS CHANGE IN BROOKLYN

M. Scharfstein has retired from the firm of Sheiman & Scharfstein, talking machine dealers of 1135 Flatbush avenue, Brooklyn, N. Y., and the business is now being carried on by Mr. Sheiman.

John G. Clark, of Holyoke, Mass., has acquired a part interest in the Victrola and piano business conducted by J. G. Heidner in that city.

ABRAM DAVEGA ELECTED PRESIDENT

New Officers of the Knickerbocker Talking Machine Co. Elected—Joseph Schwetz Becomes Vice-president of Company—Other Officers

A meeting of the board of directors of the Knickerbocker Talking Machine Co., Victor wholesaler, New York City, was held at the headquarters of the company on October 31. At this meeting officers were elected for the ensuing year. Abram Davega, who conducted this business for many years as vice-president, was elected president, filling the office made vacant by the death of his beloved father. Joseph Schwetz was elected vice-president and Louise Davega, widow of the deceased former president, secretary and treasurer. The directors are Abram Davega, Louise Davega and Henry Moses.

Joseph Schwetz, who was made a member of the firm and elected vice-president, has earned this honor through many years of conscientious work and exceptional ability. Mr. Schwetz joined the organization some nineteen years ago, which was then operated under the name of I. Davega, Jr., Inc., and for many years has been right-hand man to Mr. Davega in the conduct of the business. Although a young man, Mr. Schwetz's experience in the talking machine field even antedates his connection with the Davega firm. He has seen it grow from its infancy and reach its present large proportions. It was fitting and just that his allegiance and faithfulness be thus recognized.

INTRODUCE NEW CONSOLE MODEL

Cole & Dunas Introduce "The Olympian" in Three Styles—Small Goods Activity Grows

CHICAGO, ILL., November 10.—The firm of Cole & Dunas has just brought out a new console model, which will be known to the trade as the "Olympian" apartment model. This new instrument comes only in mahogany and retails at \$85. In size it is 33½ inches long, 36 inches high and 21 inches deep. It is of the period model type in three styles—Hepplewhite, Italian Renaissance and Queen Anne. In the past few weeks the small goods business of this house has grown to a considerable extent. This concern was one of the first to introduce a complete line of jazz instruments and drums to the talking machine dealer. The retail dealer was quick to see the possibilities of these instruments and other small goods as quick turnovers. In many instances this proved the salvation of numerous dealers throughout the country, when the buying public let up on the purchase of talking machines. The shipping department of Cole & Dunas for the past three weeks has been working overtime until one o'clock on Monday, Wednesday and Saturday nights in order to catch up with the shipping demands of dealers who are putting in complete lines of jazz stringed instruments.

BOSTON FIRM OBTAINS CHARTER

BOSTON, MASS., November 9.—A new corporation formed lately is that of the Federal Talking Machine Co., to handle talking machines, with a capital of \$25,000. The incorporators are Ralph Silverman, of Winthrop; David H. Bloom, of Boston, and George Rosen, of Malden. Messrs. Silverman and Rosen are both well known in the talking machine business and have been associated under the name of the Phonograph Supply Co. of New England.

EARL MURDOCK OPENS VICTOR SHOP

IRONTON, O., November 7.—A formal reception marked the opening here of one of the finest Victrola establishments in this section of the State by Earl Murdock. The store, which is located at 205 South Third street, is beautifully decorated and a complete line of Victrolas and Victor records has been installed. Sound-proof booths and other conveniences make the establishment complete in every detail.

JOINS WURLITZER SALES FORCE

Herbert A. Brennan, manager of the Victrola department of the R. Wurlitzer Co. store on Forty-second street, New York, has just recently added to his staff Terence F. Moran, who comes in the capacity of assistant. His experience covers a period of more than twelve years, all of which were spent in the Victor field. He was at one time manager of Landay's Forty-second street store, and later was employed by the Gram-o-phone Co. of Canada as manager of its retail store.

GUS NUNNSTIEHL HAS NEW POST

LOUISVILLE, KY., November 7.—Gus Nunnstiehl, formerly manager of the Columbia and Brunswick departments of Herman Straus & Sons Co., of this city, is now associated with the talking machine sales staff of the Stewart Dry Goods Co. Mr. Nunnstiehl is an experienced salesman, having been connected at various times with the Wurlitzer Co., the L'Harmonie Co. and others and he comes to his new connection well equipped to make a success of his new enterprise.

BEE CROFT

Delivery Envelopes

Art Series
New Designs

Now that many of the good old records are coming, the 60-day service will be more appreciated than ever.

NEW LIST OF RECORDS

Write for Revised Prices

Every 60 Days

A Selected List of Victor Records

We Will Be Pleased to Play Any of Them for You	
10028-10	Beautiful Swan Song (Santel) (Santel)
10029-10	Clair de Lune (Santel) (Santel)
10030-10	The Blue Bird (Santel) (Santel)
10031-10	The Blue Bird (Santel) (Santel)
10032-10	The Blue Bird (Santel) (Santel)
10033-10	The Blue Bird (Santel) (Santel)
10034-10	The Blue Bird (Santel) (Santel)
10035-10	The Blue Bird (Santel) (Santel)
10036-10	The Blue Bird (Santel) (Santel)
10037-10	The Blue Bird (Santel) (Santel)
10038-10	The Blue Bird (Santel) (Santel)
10039-10	The Blue Bird (Santel) (Santel)
10040-10	The Blue Bird (Santel) (Santel)
10041-10	The Blue Bird (Santel) (Santel)
10042-10	The Blue Bird (Santel) (Santel)
10043-10	The Blue Bird (Santel) (Santel)
10044-10	The Blue Bird (Santel) (Santel)
10045-10	The Blue Bird (Santel) (Santel)
10046-10	The Blue Bird (Santel) (Santel)
10047-10	The Blue Bird (Santel) (Santel)
10048-10	The Blue Bird (Santel) (Santel)
10049-10	The Blue Bird (Santel) (Santel)
10050-10	The Blue Bird (Santel) (Santel)

Very attractive proposition to Jobbers

Order Now for the Holidays

CLEMENT BEECROFT

5546 North 5th Street
PHILADELPHIA

"DA-LITE" SERVICE PROVES POPULAR

New Display Service for Victor Dealers Meets With Success—Has Many Distinctive Features

The Da-Lite Electric Display Co., of Toledo, O., is making rapid headway in establishing distributing arrangements with Victor wholesalers throughout the country. This company manufactures a display service for Victor dealers that is proving one of the most successful and popular dealer helps that has been introduced to the trade in recent years.

A large number of Victor dealers throughout the country have already arranged to use the service and all of them state that it is proving a material factor in stimulating record sales. The display is unique in many respects, having a wave of colored light flashed over its face which invariably attracts the attention of the passers-by. It measures only 13½ by 9½ inches, occupying no more space than the average display sign.

The service consists of four artistic highly colored panels each month, and, according to the company's figures, the total cost for this service and electricity is only 30 cents per day. The Da-Lite Electric Display Co. is leasing its service to Victor wholesalers exclusively and the value of the service is making an effective appeal to Victor wholesalers generally who are co-operating with the company in the introduction of this display service to Victor dealers.

SOUTHERN PACIFIC CUTS RATES

The Southern Pacific Co. has made a drastic cut in freight rates on many articles, which will become effective as soon as approved by the Interstate Commerce Commission, according to a report emanating from the headquarters of the company. In some cases the rates have been cut in half, but the average cut is 20 per cent in its specific territory.

A VISITOR FROM NEW ZEALAND

E. J. Hyams, of Wellington, Visits a Number of Prominent Centers in the United States and Canada—Places Orders for Musical Instruments and Other American Products

Among the prominent visitors to the United States during the past six weeks was E. J. Hyams, of E. J. Hyams, Ltd., of Wellington, New Zealand. Mr. Hyams is the wholesale representative of the Gramophone Co., Ltd., London, and distributes "His Master's Voice" products to about eighty dealers in that thriving section of the British Empire. He also handles American player-pianos, which are very popular in his country, and during his visit he placed a number of orders for these instruments to be shipped to a large number of dealers in New Zealand.

During his stay in the metropolis Mr. Hyams was a caller at The World office and discussed conditions in New Zealand most interestingly and informatively. In addition to talking machines and pianos Mr. Hyams represents a great number of other lines—in fact, he has divided his trading allegiance practically on a fifty-fifty basis between the United States and Great Britain. From New York Mr. Hyams went to Chicago and Canada, and on his return to this city he left for London, England, from which point he will journey homeward.

Mr. Hyams is a splendid type of business man—progressive, alert to every new idea. He has the happy knack of being able to analyze conditions quickly and correctly and to derive conclusions that are beneficial to his business and to those with whom he has intercourse in a commercial way.

Previous to his leaving for London Mr. Hyams was interviewed by a reporter of the New York World. This is what he said:

"While you New Yorkers are figuring out your Winter coal supply, New Zealand is getting ready for Spring. The first Tuesday in November is celebrated by the great Melbourne Cup race, which will be attended by about 150,000 people. At Christchurch, New Zealand, the New Zealand Cup will be run on the same date before 50,000 racing enthusiasts. It has been said that Australasia should be named 'Horsetralia' because of the love of the inhabitants for the races.

"It is a great part of the world to live in," Mr. Hyams went on. "The most expensive hotels, which compare favorably with the best anywhere, make a rate of \$6 a day for a good room with meals, and everything else included, and living conditions are equally reasonable."

REYNALDS CHRISTMAS CLUB SALES

Pian Stimulates Immediate Sales and Adds Live Prospects to List—E. W. Guttenberger, Manager, Joins the Artophone Corp.

MOBILE, ALA., November 8.—The Reynalds Music House, Victor distributor for this territory, is conducting a successful campaign for sales during the Christmas season through the medium of Christmas Clubs. The plan, though not new, is proving extremely successful and possesses a twofold value. In the first place, customers who have actually made up their minds to purchase a Victrola as a Christmas gift are eagerly taking advantage of the opportunity, and, secondly, many inquiries concerning these machines are being received by the company, which is thus enabled to add real live prospects to its list for future consideration. E. W. Guttenberger, for the past six years manager of the company, has resigned and is now connected with another concern.

NEW STORE OPENED IN NEW YORK

The Morningside Music Shop opened very attractive quarters this week at the corner of Eighth avenue and 120th street, New York. It announces that Victor, Columbia, Sonora and Brunswick machines and records will be handled.

MANDEL PHONOPARTS CO. FORMED

Has Succeeded the Mandel Mfg. Co. and the Chicago Ferrotyp Co. in the Manufacture of Talking Machine Hardware and Specialties

CHICAGO, ILL., November 9.—The Mandel Phonoparts Co., headed by H. Mandel, has succeeded the Mandel Mfg. Co. and the Chicago Ferrotyp Co. in the manufacture of motors, tone arms, reproducers, automatic stops and talking machine hardware generally. The plant of the company has been moved to commodious quarters at 1329 West Lake street, where considerable new equipment has been installed and where facilities will be available for the manufacture of various talking machine specialties on a thoroughly efficient basis.

NEW LONDON MUSIC SHOP OPENS

NEW LONDON, Wis., November 9.—The Music Shop, an exclusive Edison shop, which opened here on North Water street last week, is one of the finest music establishments in this vicinity. The building which houses the new business was completely remodeled and redecorated, sound-proof demonstration booths were installed, and many other features were added for the convenience of patrons.

VICTOR ARTIST FLIES TO CHICAGO

Reinald Werrenrath, well-known Victor artist and baritone of the Metropolitan Opera Co., traveled from New York to Chicago by airplane on Friday of this week, to appear at a recital in that city. The first landing was made in Cleveland, where Mr. Werrenrath remained for the night. The journey was completed Saturday afternoon. A Curtis plane, piloted by the assistant chief pilot of the Curtis Co., was used for the trip.

The A. Gressett Music House and the Meridian Chair & Furniture Co., talking machine dealer of Meridian, Miss., had attractive exhibits at the recent fair held in Meridian.

STATEMENT OF THE OWNERSHIP, MANAGEMENT, CIRCULATION, ETC., REQUIRED BY THE ACT OF CONGRESS OF AUGUST 24 1912, Of The Talking Machine World, published monthly at New York, N. Y., for October 1, 1921.

STATE OF NEW YORK,
COUNTY OF NEW YORK, ss:
Before me, a Notary Public, in and for the State and county aforesaid, personally appeared J. B. Spillane, who, having been duly sworn according to law, deposes and says that he is the Editor of The Talking Machine World, and that the following is, to the best of his knowledge and belief, a true statement of the ownership, management (and if a daily paper, the circulation), etc., of the aforesaid publication for the date shown in the above caption, required by the Act of August 24, 1912, embodied in section 443, Postal Laws and Regulations, printed on the reverse of this form, to wit:
1. That the names and addresses of the publisher, editor, managing editor, and business managers are:
Publisher—Edward Lyman Bill, Inc., 373 Fourth avenue, New York City.
Editor—J. B. Spillane, 373 Fourth avenue, New York City.
Managing Editor—J. B. Spillane, 373 Fourth Avenue, New York City.
Business Manager—None.

2. That the owners are: (Give names and addresses of individual owners, or, if a corporation, give its name and the names and addresses of stockholders owning or holding 1 per cent or more of the total amount of stock): Edward Lyman Bill, Inc., 373 Fourth avenue, New York City; Caroline L. Bill, New Rochelle, N. Y.; J. B. Spillane, 373 Fourth avenue, New York City; J. Raymond Bill, 373 Fourth avenue, New York City; B. B. Wilson, 373 Fourth avenue, New York City; Carleton Chace, 373 Fourth avenue, New York City; E. P. Van Harlingen, 209 South State street, Chicago, Ill.

3. That the known bondholders, mortgagees, and other security holders owning or holding 1 per cent or more of total amount of bonds, mortgages, or other securities are: (If there are none, so state.) None.

4. That the two paragraphs next above, giving the names of the owners, stockholders, and security holders, if any, contain not only the list of stockholders and security holders as they appear upon the books of the company but also, in cases where the stockholder or security holder appears upon the books of the company as trustee or in any other fiduciary relation, the name of the person or corporation for whom such trustee is acting, is given; also that the said two paragraphs contain statements embracing affiant's full knowledge and belief as to the circumstances and conditions under which stockholders and security holders who do not appear upon the books of the company as trustees, hold stock and securities in a capacity other than that of a bona fide owner; and this affiant has no reason to believe that any other person, association, or corporation has any interest direct or indirect in the said stock, bonds, or other securities than as so stated by him.

5. That the average number of copies of each issue of this publication sold or distributed, through the mails or otherwise, to paid subscribers during the six months preceding the date shown above is (This information is required from daily publications only.)

J. B. SPILLANE, Editor.
Sworn to and subscribed before me this 30th day of September, 1921.
(Seal) EUGENE R. FALCK,
Notary Public No. 6.
(My commission expires March 30, 1922.)

CABINETS
MODERATE PRICES
IMMEDIATE DELIVERY



Cut shows our
New 48"
E Model

Send for circular of our line

Everett Hunter Mfg. Co.
McHENRY, ILL.

“PROCRASTINATING OPTIMISM” IS AN UNWISE POLICY

Some Pertinent Deductions Based Upon Observations on Conditions as a Result of a Recent Tour of Western Territory—A Time for Action and Not Theorizing

On a recent trip through the West the writer came upon a phrase that most aptly describes the frame of mind of a great many business men of the country, including some of those in the talking machine industry, regarding the present trade situation and the outlook. In referring to a number of retailers, a wholesaler remarked that too many of them were suffering from what he termed “procrastinating optimism,” and were losing valuable time waiting for their optimistic prophecies to be fulfilled rather than making efforts right now to fill them.

“I have been in close contact with a great number of dealers,” said this wholesaler, “and have found that the pessimistic, down-in-the-mouth type is a rather rare bird. Business is poorer in some sections than in others, but the average merchant believes that it is only a temporary condition and is of the opinion that the early Winter months will certainly see a re-awakening of the buying spirit and a gradual but general return of good business.

“The trouble, however, is that too many merchants feel rather content to move along according to normal impulses, and to wait for the turn of the tide, rather than to do their share individually to stimulate sales by increased effort. They are at heart optimistic, but are simply procrastinating and waiting for the expected good business to drop out of the sky, as it were.

“The old adage to the effect that the Lord helps those who help themselves is to be applied most successfully to the business situation to-day. The fellow who is simply an optimist and waits for good times to come is bound to lose ground. What we want is the optimist who has enough faith in the future to get out and hustle now so that he can have a first-class running start when the break in business comes.”

The wholesaler happened to be in a line connected in some respects with the music business,

and his sermon might be taken to heart by a number of members of the music industry in all its branches. It is a self-evident fact that the methods that brought business a year or two ago are not producing results now, nor can it be expected of them. The change in the industrial situation has made it necessary to look out for, and cater to, new classes of buyers. The “white collar” man, for instance, is again coming into his own slowly but surely, and will soon be worthy of consideration as a prospect for musical instrument purchases. Then, again, new selling methods must be given consideration—selling methods that are not only calculated to appeal to the new buying classes, but which may be expected to have a proper effect upon the public as a whole.

Just simply waiting for the break to come, whining and complaining a little, perhaps, but doing practically nothing outside of the regular routine to stimulate sales, is not going to get the average merchant anywhere. If he gives the matter any real consideration he must realize that the competitor who is increasing and gingering up his sales staff, spending more money for advertising and using more energetic methods right along the line, is not only capturing all the business that might be expected to come to his store in the ordinary course of events, but is also getting business that might properly be expected to go to the other fellow—in this instance the neighboring merchant who is marking time.

It is all very well to make plans for the bright future that is to come, for it is good generalship to make plans, but it is the immediate carrying out of those same plans before the opposition takes similar steps that wins battles, whether it be in war or in business.

The time is now ripe for action and not for mere conversation.

F. K. PENNINGTON'S NEW POST

Popular Talking Machine Man Now General Sales Manager of A. B. Dick Co.—Well Known and Esteemed in Merchandising Circles

Frank K. Pennington, formerly assistant general sales manager of the Columbia Graphophone Co., has been appointed general sales manager of the A. B. Dick Co., Chicago, manufacturer of the Edison-Dick mimeograph. Mr. Pennington will make his headquarters at the



Frank K. Pennington company's executive offices, 740 West Jackson Boulevard, Chicago.

Although he was connected with the talking machine industry only four years, F. K. Pennington won the esteem of talking machine dealers from one end of the country to the other. Thoroughly conversant with every phase of merchandising and possessing a most pleasing personality, he was accorded an enthusiastic reception wherever he visited, and his many friends in the trade will be delighted to learn that he has become associated with one of the greatest industrial concerns in the country. His success is assured judging from his notable achievements in the past.



Receiver's Sale
The
Cirola
Phonograph Corp. Plant
At 393 High Street, Newark, N. J.

Modern four-story brick building containing over 20,000 square feet of floor space—Complete wood-working shop capable of turning out (150) one hundred and fifty CIROLA cabinets a day—Varnish room with latest type Air-brush equipment—Complete machine shop for machining all metal parts—2,000 CIROLAS in various stages of completion—Hardware—Supplies—Dies—Patterns—Jigs—Special tools—Good-will, Patents, Patents pend-

ing, Registered Trade-mark “CIROLA”—Motor Truck—Office Equipment—Etc.
The CIROLA has been sold all over the WORLD—This plant kept together and operated should be developed into a wonderful business.
To be sold according to the order of The Chancery Court. Terms and conditions of sale and detail description of plant and equipment furnished on application

Sale 10 o'clock, Friday, December 9th, 1921
at 393 High Street, Newark, New Jersey

MERRITT LANE, Attorney for Receiver
No. 196 Market Street, NEWARK, N. J.

HARRY A. AUGENBLICK, Receiver
No. 810 Broad Street, NEWARK, N. J.

SENATE PASSES NEW TAX BILL

Measure Now Goes Before Conference Committee of House and Senate for Final Adjustment—Expected to Be Ready in December

WASHINGTON, D. C., November 9.—The Senate on Monday night finally passed the revised Revenue Bill, which now goes to the Conference Committee representing the Senate and the House for adjustment with the House Bill which was passed on August 20. It is probable that the differences between the Senate and House bills will cause some sharp contests, and it is not expected that the final draft of the measure will be adopted until December.

The Senate Bill as finally passed not only eliminates the excise taxes on musical instruments as a result of the special amendment introduced by Senator Frelinghuysen, but repeals the excess profits tax, all transportation taxes, and grants relief in other directions.

As soon as the Senate had acted to eliminate excise taxes on musical instruments of all kinds the Music Industries Chamber of Commerce immediately started a campaign among members of the trade and others in all States represented by Senators or Representatives in the Conference Committee of the Senate and House which will finally iron out the differences between the Senate and House bills and prepare the final draft of the tax measure. The Chamber urged that those interested write immediately to the members of the Conference Committee to prevent any attempt that may be made to replace the taxes on musical instruments in the final bill.

SAMUEL BUEGELEISEN IN EUROPE

Samuel Buegeleisen, head of Buegeleisen & Jacobson, importers and wholesalers of musical merchandise, New York City, is at present in Europe visiting the various musical merchandise markets in that continent in search of additional merchandise for this house.

INSTALLS "TALKER" DEPARTMENT

The Tepper Bros. department store, of Fort Wayne, Ind., recently installed a talking machine department, with Arthur G. Fedewa and C. Sauers in charge. Mr. Tepper was formerly associated with Wolf & Dessauer as manager of the talking machine department of that well-known institution. The new department is modernly equipped throughout and a complete stock of machines and records has been installed.

ANNOUNCING—

THE OPENING OF OUR NEW EASTERN FACTORY FOR THE

Manufacture of Record Envelopes

Eleven years' experience—Specializing in such manufacture. For many years supplying record envelopes to all the largest manufacturers.

SEND FOR SAMPLES and QUOTATIONS on our latest style envelope—with highest grade printing. Immediate deliveries



Western Envelope Corporation

55-67 Hope Street

Brooklyn, New York

AN ARTISTIC TALKER DEPARTMENT

The City Furniture Co., of Chicago, Arranges Very Complete Talking Machine Department

CHICAGO, ILL., November 10.—The City Furniture Co., of this city, one of the largest furniture stores on the South Side, has just taken on a large store next to its main headquarters at Sixty-second and Halsted streets, and has placed it entirely at the disposal of musical instruments. The new music department is one of the most sumptuous in Chicago, and the largest part of this new addition is devoted exclusively to Brunswick talking machines. The demonstration booths, eight in number, are all nine by twelve feet, and the walls are of triple plate glass. These glass walls are erected in two layers with a vacuum space between each. This method of construction causes the walls to be positively sound-proof. Each booth is handsomely decorated with the costliest kind of furniture, and an idea of the expense that was gone to may be arrived at when the cost of the carpeting alone is considered. This carpet is of a dark blue color and is made in one piece, and the walls of the demonstration booths are laid upon it. The cost of this carpet alone directly from the mills at wholesale price was a little over \$1,200. Besides Brunswick talking machines and records this company is also handling the well-known line of Kimball pianos and players and Q R S music rolls.

WM. PHILIPS TELLS OF ACTIVITY

William Philips, president of the William Philips Phono Parts Co., New York City, reports that the demand for tone arms and reproducers is continuing in the good volume reached last month and further expects that this good condition will prevail throughout the coming year.

UNICO TABLES FOR VICTROLAS

Unit Construction Co. Announces Addition to Line of Tables of the Unit Type

PHILADELPHIA, PA., November 12.—The newest development in the line of Unico tables for Victrolas produced by the Unit Construction Co., of this city, is the Unico Four-Six A. Last month the Unico table No. 50 for the Victrola portable was placed on the market. Following that the Unico table Four-Six for Victrolas 4 and 6 was announced. Unico Four-Six A differs from the Four-Six in that it is equipped with a special shelf above the record shelf. This allows the convenience of using this shelf for records



Unico Table Four-Six A

that have been picked out to be played. The Unico table No. 1 is similar to the Four-Six A in construction, except that the top is perfectly flat and although a machine can be placed upon it its primary use is for table purposes. The top, however, is removable, which converts it instantaneously into a regular Four-Six cabinet stand. All these tables are of the Unit type and are easily disassembled or assembled. Delivery on the Four-Six tables is expected about November 15.

MODERNOLA SALES INCREASING

George Seiffert, president of the Modernola Sales Co., New York City, has the entire line of Modernola phonographs, made by the Modernola Co., Johnstown, Pa., on display at his headquarters. Mr. Seiffert, who is the Eastern distributor for these machines, reports that orders are coming in in excellent volume and are now being received for future delivery.

D. R. Doctorow, talking machine manufacturers' agent at East Forty-second street, New York, reports an increasing demand for the various talking machine parts and supplies which he handles.

Children Rule Your Holiday Trade

And you can delight them with a BABY PHONOGRAPH and a set of BOBOLINK BOOKS.



Wire or Write for Dealers' Proposition

SYMPHONY MUSIC COMPANY

1020 Wilson Avenue

Chicago, Illinois

GILBERT Bobolink Book \$1⁰⁰

The Most Unusual Dollar Value in the World Today

A unique and extremely beautiful assortment of outfits designed particularly for children. Each set contains a book on which no expense has been spared in our efforts to produce the most beautiful and practical child books on the market. Cover and inside illustrations, which are reproduced in full colors on special inserts, were made by the foremost child artists of the country. Willy Pogany illustrating the song books, Maud and Miska Petersham the reading books. There are with each set also, two 7-inch, double-faced records that can be played on the standard makes of phonographs. They are records prepared especially for children with child songs and sayings, so clearly enunciated that children do not have the usual difficulty in understanding them.



There are four Bobolink Books—2 song books with piano scores and records, 2 reading books with records. Each book is 18x11 inches and opens flat.

Retails for \$1.00 Each

The entire outfit, which is packed in a folding cardboard container, beautifully printed in four colors with space for name and address can be mailed without further wrapping—retails at \$1.00.

Once you see this wonderful value you will absorb some of our enthusiasm for it.

Send for Catalogs and Price List

The A. C. Gilbert Company

460 Blatchley Ave. New Haven, Conn.

General Sales Office
200 FIFTH AVENUE, NEW YORK CITY
San Francisco Chicago Toronto London



Bobolink Books are packed in folding mailing wrapper with 2 double-faced, 7-inch records.



OPERATONE



OPERATONE

A splendid Gift

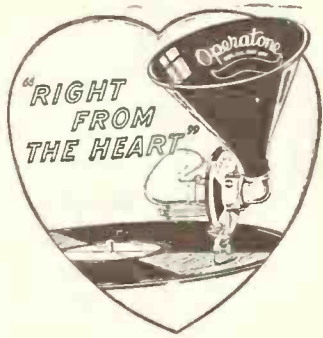

The reasons why—
the phonograph owner
buys the **OPERATONE**



- Improves the tone-quality.
- Produces the desired full rich tone.
- Brings out hidden values from your records.
- Gives realism to vocal selections.
- Eliminates the sharpness of the needle.
- Increases the volume—with better effect.
- Uses the power from both sides of diaphragm.
- Improves with age—unaffected by weather.
- Gives the true timbre to each instrument.
- Clearly reproduces all overtones.
- Has the real pep and snap of dance numbers.
- Superbly renders Grand Opera selections.
- Constantly adds to your pleasure and joy.
- And, at a cost of only \$12.50, adds \$100.00 to your enjoyment from your present instrument.



There are hundreds of idle machines right in your district—they only need something novel and different to again become active buyers of records

Canvass your entire territory—*with records*, and the

OPERATONE

a novel duplex-type of sound-box with its wood fibre diaphragm and unique amplifier

One dealer in each territory can dominate all others by selling the **OPERATONE**. Every owner is a potential buyer, regardless of the make of machine. Hundreds of idle phonographs are being restored to a renewed activity and *record buying*.

You know in advance many lovers of good music who will appreciate the wonderful tone-quality, the increased volume and definition. You can sell these people without delay—they will spread the good news.

You take no risk—because the **OPERATONE** is guaranteed "to improve tone-quality and volume of *your* instrument to *your* satisfaction or return in 10 days for Money Back."

Our distributors are well equipt and aggressive in pushing the sales and advertising campaign—in real cooperation with their dealers. They are making money for themselves and for their connections and increasing the sale of records and supplies. Every detail of practical cooperation is at your command.

The situation at a glance:—Dealers make \$60.00 per dozen profit—plus record sales!

From the Grafonola Company of New England, 174 Tremont St., Boston, Mass.

. . . You are doing business 100% and I certainly like the spirit and cooperative interest you have shown so far. It is the one thing that makes a concern want to work successfully as a distributor of your merchandise. This cooperation and your thoughtfulness look awfully good to Erisman and for your information, let me advise that we will need a couple more gross of those Operatones and we will need them just as fast as you can get them here. . . .

From the Cabinet and Accessories Co., Inc., 145 E. 34th St., New York.

. . . Just a word to let you know how pleased we are with the good word we hear from everyone about the **OPERATONE**. We certainly appreciate the cooperation you give our customers in advertising. Many of our dealers have reached customers whom they have not heard from in months and have sold quantities of records through this medium. . . .

Delays bring neither customers nor profits, without which business is poor. Get busy with the **OPERATONE as a means to an end—your record sales will jump, new customers will come in—and—you will find that IT PAYS!**

Order a trial dozen now, and sell them at once. You surely know those who would wish the first ones to reach your district—schedule those deliveries as a personal favor. This is being done by others.

Retail price, \$12.50—sold to dealers at \$90.00 the dozen, with quantity credits. Each dozen earns \$60.00 or more, and sells two more dozen by personal recommendation—and many extra records. It pays!

Our production will permit
of a few more connections

THE NATURELLE
REPRODUCTIONS
CORPORATION

5 West 39th Street, New York
Tel. Longacre 6957



ALL READY FOR THE BIG BALL

Grand Ball of Talking Machine Men, Inc., at Hotel Pennsylvania Promises to Be Great Success—Several Orchestras to Provide Music

As The World goes to press all preparations have been completed for the grand ball of the Talking Machine Men, Inc., to be held at the Hotel Pennsylvania, New York, on Thursday evening, November 17. Not only have the preparations been completed, but there have already been a sufficient number of tickets sold to insure the entire success of the venture. The general public has responded most satisfactorily to the opportunity for dancing to the music of close to a half-score of the prominent orchestras whose music has become familiar through the medium of talking machine records of various makes.

Plans have been made for a continuous flow of music from 8.30 p. m., at which time the ball starts, until the wee sma' hours of the following morning. There will be an official orchestra and, in addition, such organizations as the All Star Trio, The Happy Six, Columbia artists; the Pennsylvania Hotel Orchestra, which has made a number of Victor records; the Paul Beise Trio, Columbia; Ted Lewis and his Jazz Band; Prince's Orchestra, and very probably Isham Jones and his noted orchestra, Brunswick, who are in New York to do some recording. Paul Whiteman and his Palais Royal Orchestra, whose Victor records have proven a sensation, is also expected to be present and offer some entrancing melodies for the active feet, and there will be several others. In short, it promises to be a real musical evening.

The profits that accrue from the affair will be devoted by the Talking Machine Men, Inc., to the financing of various trade betterments, including joint advertising campaigns and other movements of like character calculated to benefit the local retail trade as a whole.

A. H. MAYERS MOVES

A. H. Mayers, for several years engaged in the talking machine business on Broadway, between Sixty-eighth and Sixty-ninth streets, New York, has vacated this establishment and moved into a more spacious store at 1995 Broadway. Mr. Mayers will occupy both the first and second floors at his new location. The establishment is being thoroughly remodeled. Columbia and Victor machines are handled by Mr. Mayers.

NEW VICTOR GERMAN CATALOG

The Victor Talking Machine Co., of Camden, N. J., announces that the new German catalog, containing twenty-seven records, is expected to be ready for distribution during the latter part of this month. Twelve new records in German have been added; three are new combinations of old popular numbers and twelve have been restored from the 1920 cut-out list. These will also appear in the 1922 general record catalog of the Victor Co.

BANKRUPTCY PETITION FILED

CHICAGO, ILL., November 9.—A petition in bankruptcy was filed to-day against the Phonograph Motors Corp., of this city, by the Etching Co. of America and Bowen D. Chace. This company formerly manufactured the Johnson electric motor.

HONOR BRUNSWICK ARTIST

HOLLYWOOD, CAL., November 7.—The Reed & Dady exclusive Brunswick shop, 6611 Hollywood boulevard, recently honored Hollywood's whistler, Margaret McKee, in celebration of her first Brunswick records, which were recently placed on sale. In their display window was a beautiful woodland scene artistically done, centered around Miss McKee's photograph.

It was in the bird songs that Miss McKee first won her place among America's foremost whistlers.

ISAAC DAVEGA'S WILL IS FILED

Will of the Former President of the Knickerbocker Talking Machine Co. Places Bulk of Estate in Trust—Business to Continue

According to the will of the late Isaac Davega, formerly president of the Knickerbocker Talking Machine Co., Victor wholesaler, New York City, the bulk of the estate is placed in trust. Mrs. Louise Davega, widow, receives the income from one of the trust funds, while Abram Davega, son, and Mrs. Byron R. Forster, daughter, are recipients of the income from other trust funds established. It is directed in the will that the directors continue the business of the Knickerbocker Talking Machine Co. as heretofore and it is stipulated that "the surplus which

I have been accustomed to maintain in such corporation so that it may not be disturbed" be continued.

MAKING IRISH RECORDS

The Gaelic Phonograph Record Co., which is making a specialty of Irish records at its headquarters, at 637 Madison avenue, New York, is under the personal supervision of Hugh P. Fay. At the present time records in Gaelic by Nora Powers are being featured with no small measure of success.

A new Victor establishment has been opened in Cedar Rapids, Ia., by E. C. Mitvalsky. Mickel Bros. Co., Victor distributor, supplied the stock.

FAVORITE MAIN SPRINGS OF HIGHEST QUALITY

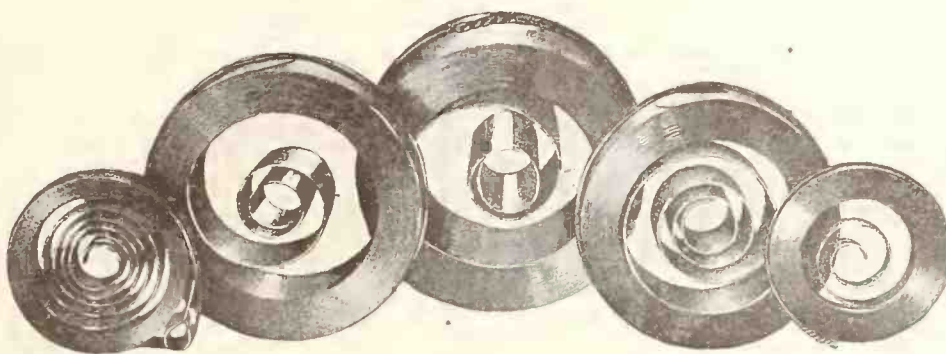

and Phonograph Repair Parts, Motors, Tone Arms Sound Boxes, Cabinet Hardware and Accessories

Main Springs Tone Arms

TEMPER AND LENGTH GUARANTEED

2 in. x 0.22 x 16 ft., Meisselbach No. 18..	Each	\$1.25
1 1/2 in., for Edison Disc	Each	1.25
1 1/4 in. x 0.22 x 17 ft., reg. Victor.....	Each	0.60
1 1/4 in. x 0.22 x 17 ft., Victor new style.....	Each	0.60
1 3/16 in. x 0.25 x 16 ft., Heineman No. 44....	Each	0.60
1 in. x 16 ft., oblong hole, for Meisselbach Nos. 16-19	Each	0.50
1 in. x 16 ft., oval hole, for Crescent.....	Each	0.50
1 in. x 0.25 x 12 ft., Heineman No. 33 & 77..	Each	0.40
1 in. x 0.28 x 10 ft., for Columbia	Each	0.40
1 in. x 0.20 x 13 ft., Victor	Each	0.40
1 in. x 0.20 x 13 ft., Victor new style.....	Each	0.40
3/8 in. x 0.23 x 10 ft., for Bilek motor.....	Each	0.28
3/8 in. x 0.25 x 10 ft., oval hole	Each	0.28
5/8 in. x 0.22 x 8 ft., for Swiss motor.....	Each	0.22
5/8 in. x 0.25 x 11 ft., for Edison	Each	0.22

No. K with sound box	Each	\$2.75
No. E with sound box, very loud	Each	6.00
No. M with sound box, very loud	Each	4.75
Columbia tone arm, new style.....	Each	\$3.50

SOUND BOXES

No. B 1 Bliss sound box, fit Victor.....	Each	1.75
No. B Balance, fit Victor.....	Each	0.75
No. C Balance, fit Victor.....	Each	1.00
No. F Favorite, fit Victor.....	Each	1.75
No. F Favorite, fit Columbia.....	Each	1.75
No. P Favorite, fit Victor.....	Each	2.00
No. G Glory, fit Victor.....	Each	3.75

CABINET HARDWARE

Lid supports, automatic, nickel plated..	Each	0.22
--	------	------

CONTINUOUS HINGES

Nickel, 15 1/2 in. long.....	Each	0.25
------------------------------	------	------

NEEDLE CUPS

Highly nickel-plated	Per 100	1.50
Covers for cups	Per 100	0.75
Highly gold-plated	Per 100	7.00
Cover gold-plated	Per 100	5.00

REPAIR PARTS

Columbia driving shaft, No. 11778.....	Each	0.50
Columbia bevel pinion, No. 12333.....	Each	0.75
Columbia bevel pinion, latest style.....	Each	0.75
Columbia bevel pinion, No. 3189.....	Each	0.35
Columbia worm gear, No. 6409	Each	0.30
Columbia stylus har	Each	0.35
Columbia driving gear ratchet No. 2152.....	Each	0.20
Columbia cranks, 3 sizes	Each	0.45
Columbia governor weights	Each	0.08
Columbia governor shaft, No. 3004.....	Each	0.40
Columbia governor springs	Per 100	1.00
Columbia governor screws	Per 100	0.75
Columbia barrel screws, No. 2621.....	Per 100	0.75
Columbia soundbox thumb screws.....	Per 100	1.50
Winding cranks for Victor motor, short or long	Each	0.45
Stylus bar for Victor Exhibition.....	Each	0.35
Governor springs for Victor.....	Per 100	1.00
Governor screws for Victor.....	Per 100	0.75
Governor balls for Victor.....	Each	0.08
Rubber backs for Exhibition box.....	Each	0.25
Bevel pinions for Victor, 4 sizes.....	Each	0.35
Turn-table felts, 10 in., round or square....	Each	0.15
Turn-table felts, 12 in., round or square....	Each	0.20
Motor bottom gear for Triton motor.....	Each	0.20

MICA DIAPHRAGMS

1 23/32 in. Victor Ex. Box, first grade.....	Each	0.15
1 1/8 in., new Victor No. 2 very best.....	Each	0.18
1 31/32 in., for Sonora	Each	0.20
2 3/16 in., for Columbia No. 6.....	Each	0.25
2 9/16 in., for Pathé or Brunswick.....	Each	0.45

SAPPHIRES

Pathé, very best loud tone, genuine.....	Each	0.12
Pathé, soft tone.....	Each	0.15
Edison, very best, medium tone.....	Each	0.18
Edison, very best, loud tone.....	Each	0.15
Edison, genuine diamond.....	Each	1.25

STEEL NEEDLES

Steel needles, extra loud, loud, medium and soft needles	Per 1,000	0.35
--	-----------	------

ATTACHMENTS

In Gold or Nickel-plated		
Kent attachments for Victor arm.....	Each	0.25
Kent attachments for Edison with C box, nickel or gold-plated.....	Each	2.50
Kent attachments without box for Edison, nickel or gold-plated.....	Each	1.60
Victor, Universal old style.....	Each	1.15
Columbia attachment	Each	0.25

MOTORS

Distributors for Heineman and Meisselbach Motors. Best Prices. Immediate Deliveries.

TERMS: With satisfactory rating, 2% discount for cash in 10 days, or 30 days net. Otherwise, 3% discount for cash, or 20% payment with order, balance C. O. D.

FAVORITE MFG. COMPANY

MAIN OFFICE:

105-107 East 12th Street, New York City

N. E. Corner of 4th Avenue

Telephone Stuyvesant 1666

GETS GOLD MEDAL FROM QUEBEC PROVINCIAL EXHIBITION

MONTREAL, CANADA, November 5.—The Montreal branch of the Columbia Graphophone Co. carried off the "gold medal with high distinction" at the Quebec Provincial Exhibition held in Quebec City recently. According to exhibition

rated with advertising material, special artist posters and comfortable chairs and rockers. Grafonolas of various types, including period and standard models, were displayed, and the Dealer Service exhibit carried a wide variety of



Gold Medal Certificate Awarded to the Columbia Graphophone Co.

officials, 20,000 persons entered the grounds daily and on one afternoon the crowds were so dense around the Columbia booth that it was impossible to pass.

The Columbia booth was attractively deco-

Columbia accessories which were very popular. Manager Gerard, of the Montreal branch, is most enthusiastic regarding the results of the exhibition, especially as the Montreal branch is the "baby" of the Columbia organization.

A BUSY ALBUM PLANT

Visitors to the Boston Book Co. in Chicago Find Convincing Proofs of Activity

CHICAGO, ILL., November 10.—There is no evidence of dull times at the plant of the Boston Book Co., in this city. A visitor entering this

plant sees an automatic machine known as a "case maker" that in one hour turns out the same number of albums as it formerly took sixteen men working at top speed to do in one day. The machine is twenty-five feet long, and it glues, cuts corners and fits the lining and turns the four sides of the album and drops it out completed at the other end. It is only neces-

Retail Experience

In order to be of the greatest possible assistance to the Victor dealers whom we serve, we have built an organization, every member of which has had considerable retail sales experience in the Talking Machine business. Our recommendations are made only after thorough consideration from a retail viewpoint. Someone in our organization can help solve your particular problem.

C. C. MELLOR CO.

Victor Wholesalers

1152 Penn Avenue
PITTSBURGH, PA.

sary for one man to operate this machine, and he in one day is enabled to turn out the same number of albums as it formerly took sixteen men a week to do. This machine is kept going twenty-four hours per day in order to keep up with the sales ability of Mrs. L. Gelbspan, the proprietor of the Boston Book Co. But one man and one machine are not all that Mrs. Gelbspan keeps busy in the plant over at 501 to 509 Plymouth Court. There are over a score of workers in the packing and shipping department alone, working on both the day and night shifts.

DOEHLER MADE EXPOSITION OFFICER

President of the Doehler Die Casting Co. Is Selected as Vice-president of the Brooklyn Manufacturers' Industrial Exposition

H. H. Doehler, president of the Doehler Die Casting Co., Brooklyn, N. Y., has been elected vice-president of the Brooklyn Manufacturers' Industrial Exposition, which will be held in the Twenty-third Regiment Armory, that city, during the week commencing January 14. Mr. Doehler has been active in similar affairs for many years and is well qualified to contribute to the success of the undertaking.

Musical instruments of all kinds will have a prominent place at the exposition, having been allotted an entire section on the Armory floor. All the exhibits in one line of industry will be grouped, therefore visitors interested in the musical instrument section will find these exhibits in close proximity to each other.

MR. DEALER — AT LAST IT'S HERE



Let your customers make "Homograms" Records of their own—in their homes with

THE "RECORDOLA"

The Perfect Recorder and Reproducer. May be attached to any Phonograph

Just what you have been waiting for
Simple to use—Positive in operation

Every phonograph owner a prospect

Complete "Recordola" outfit, handsomely nicked, including a double-faced "Homograms" recording blank that may be used for making 50 to 100 different records.

RETAIL PRICE \$26.00, usual trade discount

RECORDOPHONE CO., Inc., 220 Broadway, New York, N. Y.

A Dawn of Prosperity for Every Prima Donna Dealer



Stratford
\$115



Bungalow Model
\$95



Blackstone
\$135

DEALERS BONUS DISCOUNT

To prove to the trade that prices can come down without lowering the standard of the product, the manufacturer and distributor of Prima Donna have arranged a co-operative discount which all dealers will enjoy. This special additional discount has been called a DEALERS' BONUS DISCOUNT plan and will be in effect until further notice. Full details furnished on request.

Only Phonograph
Unreservedly Guaranteed
For One Year

Prima-Donna

"The Instrument Inspired"

Send
for Handsome
Catalog

For the information of dealers who may not know, we might state that the Prima Donna phonograph has led the market for the past five years, considered from a price and quality viewpoint. Prima Donna is now offered you at a further reduction by our DEALER BONUS DISCOUNT mentioned above. Dealers who know have proven this a reorder proposition.

Write for ADDITIONAL BONUS DISCOUNT NOW!

That's why the factory in back of the dealer can operate on such a small profit margin, as it has proven from the time it first introduced Prima Donna for public approval that the phonograph was made right and priced right, and the selling force had but to gain proper trade introduction and Prima Donna sold itself from the start wherever introduced.

The quality is unequalled and the price closes the sale

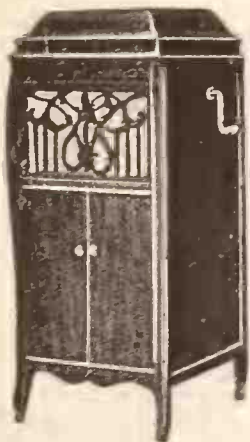

Astoria
\$160

Made in Six Models

Bungalow\$ 95	Astoria\$160
Stratford 115	Majestic 200
Blackstone 135	Parlor Grand	... 225



Parlor Grand
\$225

Quality, Style and Finish

All that one could ask is exemplified in the Prima Donna. Its construction and tone are a delight to the eye and the ear. Its tone value is increased by our scientifically constructed all-wood amplifier. Prima Donna cabinets set a new standard for beauty, style and durability and stand as a "living" example to the best produced by the cabinet makers' craft. All panels are five-ply and inserted in a continuous frame, either genuine mahogany or quartered oak. The mahogany cabinets are hand-rubbed to a high-class piano finish. In tone and craftsmanship it is truly an inspiration realized.

Frederick P. Altschul

PRIMA DONNA
Distributor

112 WEST 23rd STREET

NEW YORK



Can You Sell Foreign Records?

Now is the time to stock up on Fall and Holiday sure-fire sellers.

A. G. KUNDE

now has a complete stock of German selections and is ready to fill orders for samples in Polish, Bohemian, Hungarian, Jewish, Italian and Scandinavian languages.

**Retail Price, 85c
Regular Discounts**

*Write Now for Our
Interesting Catalog*

A. G. Kunde

*U. S. Importer and Distributor
of Homokord Records*

**344 East Water Street
Milwaukee, Wis.**

ANNOUNCES SALES PLANS OF "STRAND" PHONOGRAPHS

Manufacturers Phonograph Co. Appoints District Representatives in Important Points—All Well Known in Trade and Thoroughly Experienced—Geo. W. Lyle Discusses Company's Plans

George W. Lyle, president of the newly organized Manufacturers Phonograph Co., New York, manufacturer of the "Strand" phonograph, reports a most successful launching of the company's sales effort. Mr. Lyle advises arrangements have been concluded for high-class representation at several important points, these district representatives being men with records of exceptional selling success and all well known to the trade.

Referring to these important deals, Mr. Lyle said: "Every phonograph dealer in New England knows A. C. Erisman, who has signed as our New England distributor (and forwarded a remarkable bunch of initial orders). Mr. Erisman has seen twenty-three years of phonograph work, during which time he was employed successfully as Boston wholesale manager for the Columbia Graphophone Co. and was called from this position to the responsible one of New England district manager in direct charge of five branches or distributing points. He covered the entire New England territory personally and undoubtedly has a direct personal acquaintance with more dealers in this territory than any other one man. At the same time he has conducted one of the largest and most successful retail stores in New England, the Grafonola Shop at 174 Tremont street, Boston.

"In Detroit we will be represented by one of the largest and best-known wholesale furniture houses in the city—Ricken, Seeger & Wirts. The phonograph department will be under the direct charge of Stephen M. Wirts, who is as well known as a designer as a business man, his designs having been used in the productions of some of the best American factories, including the Berkey & Gay Furniture Co., of Grand Rapids, Mich. His idea of celebrating his present connection with the Manufacturers Phonograph Co. was to forward a batch of orders for the No. 8 console, which is his own design.

"W. O. Cardell, operating in Oklahoma territory, is better known throughout the West as 'Bill.' He has sold for one of the largest wholesale furniture houses in the country for twenty-one years; fourteen years in this same territory. He takes pride in having built his phonograph trade in just two years from nothing to the largest per capita producing territory in the United States. He actually began taking orders for Strand consoles inside of fifteen minutes from the time he landed in his territory, and his mail since then has been all orders and no conversation.

"New York City and adjacent territory will be looked after by R. H. Arnault, for several years employed as a consulting engineer with the Columbia Co., and who joined the ranks of the Pathé three years ago as factory manager. During a holiday season he offered his services to the sales department and found that 'selling

was really his forte.' He is very enthusiastic over the new company and promises to put the line over in New York in great shape. His headquarters for the present will be at the executive office, 95 Madison avenue.

"Dealers in Philadelphia and adjacent territory will be looked after by H. E. Morrison, who joined the ranks of phonograph men in 1914, starting out with the Hallett & Davis Piano Co. In 1917 he decided to go West and became head of the talking machine department of the Wright & Wilhelmy Co., the Pathé distributors in Omaha. His work with this firm was so good that in the early part of 1920 he became associated with the executive office traveling force of the Pathé Co., where he remained until the last of the year, at which time he joined the Emerson forces. He has been in the field for the Manufacturers Co. but a week and has already made a record of establishing two dealers a day.

"San Francisco and its environments will be covered by Walter S. Gray, known all over the Pacific Coast as one of the most experienced men in the talking machine business. He was for years associated with the Columbia Co., first as representative in the Orient and afterwards as Pacific Coast district manager, which position he occupied for years. He is now head of the Walter S. Gray Co., dealing in phonograph accessories, and feels that the Strand line is the 'coming talking machine,' both as to quality and price. His wire orders have already started to come in, and he is looking for a substantial holiday business."

ISSUE INTERESTING NEW CATALOG

Cabinet & Accessories Co.'s New Loose-leaf Catalog Abounds in Valuable Information

An excellent idea of the large number of accessories distributed by the Cabinet & Accessories Co., New York City, is to be found in an entirely attractive loose-leaf catalog just issued by that firm. The catalog is handsomely bound in stiff covers and permits the adding of additional accessories or necessary corrections on those listed. The articles listed are too numerous to be mentioned in detail, but include portables, cabinets for Victrolas, record and music roll cabinets, covers, albums, record lights, cleaners, needles, needle cutters, needle envelopes, motors, tone arms and reproducers; carrying cases for records, repeating devices, talking machine toys, polishes and lubricants, decalcomanie, cabinet hardware and springs, advertising novelties and children's record books. An up-to-date price list is also bound in at the back of the book. The catalog is not only attractive in appearance but will admirably serve as a guide to the well-known accessories in the talking machine field at the present date.

THE OUTING

The only Portable on the market embodying all the features of a large phonograph with:

1. A twelve-pocket album to protect the records.
2. A twelve-inch turntable to play 12-inch records.
3. A two-spring motor.
4. A universal tone arm which plays all records.
5. A tone chamber with which you can regulate the tone.
6. A piano finish and genuine mahogany top.

RETAIL PRICE \$35

Desirable Jobbing Territory Open. Write Today.



OUTING TALKING MACHINE CO.

Mt. Kisco, N. Y.

The Phonograph of Marvelous Tone

VITANOLA

Plays ALL Records - Natural as Life



Dealers—Attention!

By our direct selling campaign we are now enabled to offer you the wonderful VitanoLa at greatly reduced cost to you.

The VitanoLa product is of the highest quality and our direct-to-dealer campaign affords you a great saving in wholesale cost. This enables you to take care of the consumer demand for lower prices on high-grade machines.

Six models to choose from for immediate shipment, all adaptable for your holiday trade.

Why buy inferior machines when you can now get genuine Vitanolas at such low prices? Send your inquiries direct to us and assure yourself of clean, new goods. We have no jobbers and are shipping directly from our factory only.

Send all orders and inquiries to

VITANO LA TALKING MACHINE CO.

1900 South 52nd Avenue

Phone: Lawndale 460

CICERO, ILLINOIS

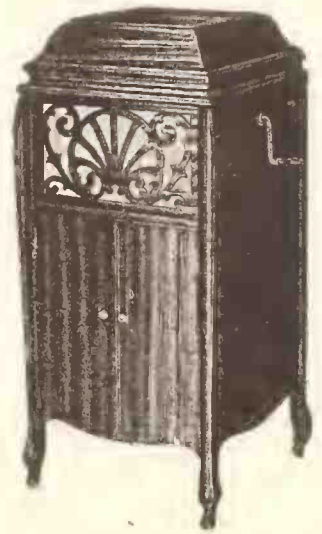

WORLD'S CLASSIFIED ADVERTISING

Any member of the trade may forward to this office a "Situation" advertisement intended for this Department to occupy a space of four lines, agate measure, and it will be inserted free. Replies will also be forwarded without cost. Additional space will be at the rate of 25c. per line. If bold faced type is desired the cost of same will be 25c. per line. Rates for all other classes of advertising on application.

VICTOR-BRUNSWICK MANAGER desires new connection. At present am managing one of largest Victor-Brunswick propositions in Eastern city of nearly million people, in department store of sixty years' prestige. Business volume in my department is averaging \$175,000 yearly and going strong. If you desire alert, efficient and creative manager, one whose motto is "Service Intelligently Dispensed," you are going to engage me. If you are willing to place entire management and responsibility of your department or store in my hands, feel certain through my eight years' talking machine experience and success, that you will enjoy realization of seeing your business on the Peak Place. My age is 32 years, possess academic education, and desire to hear from some one whose proposition is up-to-the-minute, department or store spacious, well appointed and fitted throughout with Twentieth Century furnishings. All correspondence must be confidential. Address "Box 1046," care The Talking Machine World, 373 Fourth Ave., New York.

POSITION WANTED—Expert repairman on any standard motor, also do furnishing. Am a good adjustment salesman. Prefer Brunswick or Victor. Address "Box 1051," care The Talking Machine World, 373 Fourth Ave., New York City.

POSITION WANTED—Master plater and matrix maker. Am familiar with modern methods, capable of installing plant and handling work from wax to finished stampers. Wish position with reliable company. Address "Box 1050," care The Talking Machine World, 373 Fourth Ave., New York City.

POSITION WANTED—Talking machine laboratory man and backed-up matrix expert, with 17 years' experience, 14 years with one company, wishing an interview with any talking machine company. Capable of taking charge. Address "Box 1057," care The Talking Machine World, 373 Fourth Ave., New York City.

WANTED—Large Brooklyn retail store wants two high-class Victor record salesladies or salesmen. Must know the Victor catalog thoroughly. Salary \$20 and 1 per cent commission. Address "Box 1055," care The Talking Machine World, 373 Fourth Ave., New York City.

POSITION WANTED—A thoroughly experienced Victor man, for eight years connected with the Victor line in every phase of the business. Factory and wholesale representative and an active retail managerial experience. Will consider a sound and live proposition in any branch of the business. Highest references; 28 years of age, single and will go anywhere, but prefer the West. Address "Box 1056," care The Talking Machine World, 373 Fourth Ave., New York City.

WANTED—A reliable Victrola salesman to canvass and follow up prospects; one that resides in the city of New York. Salary and commission. State former employer and what experience. Address "Box 1021," care The Talking Machine World, 373 Fourth Ave., New York City.

RECORDING ENGINEER and factory manager open for engagement. Twenty-five years' experience recording, plating, matrix-making, composition-making, pressing and superintending. Thoroughly familiar with the latest advances in every branch of the art. Address "Box 1039," care The Talking Machine World, 373 Fourth Ave., New York City.

WANTED—Salesmen now traveling to handle our varied line of talking machine record dusters on liberal commission. E. T. Gilbert Mfg. Co., Rochester, N. Y.

EXPERT REPAIRMAN wishes steady position with large reliable house; six years' experience in all makes of machines. Wishes position in New York City or Brooklyn. 29 years of age. Married. Morris E. Blumenthal, 328 Bushwick Ave., Brooklyn, N. Y.

POSITION WANTED—Recording Engineer, wide experience in all branches of record making. Work is marked by its musical quality, long wear and good appearance. Best references. Address "Box 1045," care The Talking Machine World, 373 Fourth Ave., New York City.

A SIDE LINE WITH SUBSTANTIAL PROFIT. Men now selling phonographs or benches will find it entirely profitable to sell our popular line of pianos and players. Fine as side line. Address Opportunity, "Box 848," care The Talking Machine World, 373 Fourth Ave., New York City.

EXPERT REPAIRING

Of all makes of phonographs. Parts on hand for Vitanolas, World, Elting, etc. Parcel Post your repair wants to

Northwestern Phonograph Works

218 South Wahash Ave., Chicago, Ill.
MOTORS TONE-ARMS

WANTED

Victor Red and Black Seal Records in all languages. Also parts and motors. Spot Cash Paid. Victoria Phonograph and Record Exchange, 150 East 59th St., New York City.

BUSINESS OPPORTUNITY

WANTED—Salesmen to sell a line of metal name-plates to talking machine dealers and manufacturers. Big profits. No bulky samples. Commission paid on receipt of orders. Can be handled in connection with any line. Write for our proposition to-day. Fogarty Manufacturing Co., Dayton, O.

Sacrifice Sale of 25,000 Standard

10-inch DOUBLE DISC RECORDS

Very large assortment—no patriotics.
All desirable—no patriotics.
In 100 lots, 19c. In 2,000 lots, 17c.
In 250 lots, 18½c. In 5,000 lots, 16½c.
In 500 lots, 18c. In 10,000 lots, 16c.
In 1,000 lots, 17½c. Entire stock, 15c. each.
Terms: Net F.O.B. Chicago. Subject to prior sale.
Fantus Bros., 519-531 S. Dearborn St., Chicago, Ill.

POSITION WANTED—Young man, 24 years of age, technical education, specializing in acoustics and with five years' experience in inspecting, drafting and research in the industry, wishes to connect with a high-grade talking machine concern. Opportunity and not immediate large salary sought. Address "A. R. S.," care The Talking Machine World, 373 Fourth Ave., New York City.

POSITION WANTED—Expert repairman, who can diagnose all phonograph trouble and repair same skillfully. Best references. Address "Box 1047," care The Talking Machine World, 373 Fourth Ave., New York City.

POSITION WANTED—Recording engineer, at present employed, will consider management or organization of laboratory. Familiar all branches record business. Has recording machine. Address "Box 1048," care The Talking Machine World, 373 Fourth Ave., New York City.

WANTED—Young man and wife desire charge of music store on salary and percentage basis. Will take complete charge of store and outdoor sales. Thorough experience, best references and only a permanent, dependable connection considered. Address "Box 1049," care The Talking Machine World, 373 Fourth Ave., New York City.

POSITION WANTED—Chemical engineer, graduate of Boston Institute of Technology, is desirous to connect with some manufacturer where his specialized training will be of the greatest value. Address "Box 1053," care The Talking Machine World, 373 Fourth Ave., New York City.

FOR SALE

Paasche Air Compressor 6"x6", Paasche Varnish Spray Outfit, Cutler Curtain Dry Kiln 16x25 ft. for varnish work, especially suited for talking machine manufacture. Offered at less than cost, for cash. Write for full particulars to "N. O. 2," care Talking Machine World, 209 So. State St, Chicago, Ill.

FOR SALE, PHONOGRAPH EQUIPMENT

consisting of motors, tone-arms, sound-boxes and general hardware for about one hundred machines. Offered at less than cost for cash. Write for full particulars to N. O. 4, care The Talking Machine World, 209 So. State St., Chicago, Ill.

WANTED

Phonograph records and musical merchandise. My several outlets and connections enable me to give you quick action on job lots, over-stocks and complete lines of any kind of musical merchandise you wish to liquidate. All transactions confidential. Address J. K. Morgan, Leiter Bldg., Stores, State and Van Buren St., Chicago, Ill.

OPPORTUNITY

We have about 2,000 phonograph cabinets of prominent makes, which we wish to dispose of either in the WHITE or COMPLETE. Splendid proposition for jobbers or exporters. Good opportunity for anyone wishing to enter the talking machine field without the burden of manufacturing. Mount Kisco Wood Working Co., Mt. Kisco, N. Y.

PHONOGRAPH FACTORY FOR SALE

Phonograph factory, three-story brick, modern equipment, steam-heated, automatic fire-sprinkled, fine shipping facilities, good labor market, in progressive Ohio city, 30,000. Compelled to sell; attractive price; terms. Address "Box 1054," care The Talking Machine World, 373 Fourth Ave., New York City.

FOR SALE

Modern old established music store in a town of three thousand population, in splendid farming community, within four miles of a railroad town of two thousand, without music store. Established trade on a standard phonograph and record. Situated on two steam roads and one interurban line. Will sell building and stock, or stock only with lease on building. Reason for selling, ill health. Address "Box 1041," care The Talking Machine World, 373 Fourth Ave., New York City.

MONEY MONEY MONEY

If you are in Greater New York we will make immediate advances on your phonograph leases. Very moderate terms. Details on request. Address "Box X. Y. Z.," care The Talking Machine World, 373 Fourth Ave., New York City.

SPOT CASH **We BUY**
Job Lots, Close-Outs
Discontinued Stocks, etc.
in all lines. No quantity too large. Quick Cash for bargains.
SEND SAMPLES AND FULL PARTICULARS.
BARGAIN BULLETIN FREE
FANTUS BROS., 525 S. Dearborn St. Chicago
WE BUY ANYTHING

**JOB LOT OF IMPORTED
UNUSED
HUNGARIAN, SERBIAN
and GERMAN RECORDS
WILL SELL AT BARGAIN PRICE**

100 WEST 21st STREET Room 212 NEW YORK, N. Y.

WANTED
We want the best phonograph merchandising man in the United States. He must be a man of experience, able to organize and build up a successful department in a big chain of retail furniture stores. This is a big job and none but the best man is wanted. Sell yourself in first letter. Give all details including salary. All letters will be treated confidentially. Address "Box 1044," care The Talking Machine World, 373 Fourth Ave., New York City.

FOR SALE
The Only Exclusive Victor Shop in a City of 500,000
Would consider having some money in business, but do not want to be active. This is a real opportunity for some one. Address "Box 1042," care The Talking Machine World, 373 Fourth Ave., New York City.

FOR SALE
Recording machine and tools for lateral recording. Address "Box 1043," care The Talking Machine World, 373 Fourth Ave., New York City.

FOR SALE
Half interest in established music house in central Western city of 60,000; investment for expansion of business; standard lines. Address "Box 1052," care The Talking Machine World, 373 Fourth Ave., New York City.

1900 PHONOGRAPHS
900 complete phonographs for sale; also 1,000 cabinets ready for motors, etc., all finishes. Strictly high-class (not cheap) attractive designs; low prices; immediate delivery. Address The Houghton Manufacturing Co., Marion, O.

FOR SALE
Records, cabinets, motors, tone arms and accessories. Anything required in the phonograph line we have, and sell at reduced prices. We also buy anything you have to sell in the phonograph line. Mandell & Co., 88 Rivington St., New York City.

WANTED
Reliable salesmen to sell the trade on commission. Strictly high-class phonographs—oak, walnut and mahogany—beautiful designs. Liberal commission, attractive dealer's price, immediate shipment. Manufactured by a company long established with a worldwide reputation on other products. Address F. M. Foster, Sec., No. 8, 15th, Columbus, O.

FOR SALE
Good opportunity for one who desires to purchase a large and well-furnished phonograph store. Authorized dealer for standard lines. Also handling musical instruments and sporting goods. Must sell because another store requires attention. Inquire: H. Zuckerman, 23 East Broadway, New York City.

FOR SALE
Will sell at sacrifice CENTURY EDITION Sheet Music—one full set and extra; 900 metal name plates, two-color. Can be used by manufacturer of cabinets. Attractive, with good name. Lesterphone Co., 430 West 40th St., New York City.

TO HAVE RECEPTION AND SHOWROOM

Brunswick New York Showrooms to Be Re-arranged—For Benefit of Visiting Dealers

The New York branch of the phonograph division of the Brunswick-Balke-Collender Co. is making extensive alterations in its present quarters at 35 West Thirty-second street which, when completed, will be most attractive and also better equipped to take care of the needs of Brunswick dealers. It is planned to devote the entire space near the entrance to a large and attractive reception and showroom where the new console models recently put out by the Brunswick Co. will be displayed. This room will adjoin the present one where Brunswick phonographs of every model are shown. Heretofore Chester Abelowitz has had his desk in this space, but according to the new plans it will be moved into adjoining new quarters near the entrance to the door, where Mr. Abelowitz can see and greet Brunswick dealers as they enter.

Edward Strauss, Eastern sales manager, is responsible for this move, which was prompted in the interest of the Brunswick dealer so that he may be given a greater service when visiting Brunswick headquarters. Mr. Strauss stated that a feature of the new and enlarged quarters will be a complete display of all Dealer Service material put out by the Brunswick Co. This will be displayed in such a way that dealers will be able to obtain valuable ideas on how to use this material in the retail store.

TO SELL CIROLA CORP. ASSETS

Court Orders Disposal of Newark, N. J., Property at Auction

By order of the Chancery Court, Newark, N. J., the assets of the Cirola Phonograph Corp. are to be sold at auction on Friday, December 9, on the premises, 393 High street, Newark, N. J.

The Cirola Phonograph Corp. is the manufacturer of the portable machine of the same name. The coming sale includes the modern four-story building containing over 20,000 square feet of floor space, at 393 High street, Newark, N. J.; a complete woodworking shop, with a capacity of 150 portable machines a day; a varnish room with the latest type air brush equipment; metal-working machinery, hardware supplies, dies, patterns, tools, etc. The sale also includes the complete office equipment and a delivery truck.

JAZZ CONCERT A SUCCESS

Montana Columbia Dealer Holds Jazz Concert Which Attracts Much Attention

BUTTE, MONT., November 8.—The Dreibelbis Music Shop, of this city, enterprising Columbia dealer, recently held a "Jazz" afternoon at its warehouses, which was a distinct success. The company used various publicity mediums to interest the public in this unique concert, and a window



Window Display Featuring Ted Lewis Records display was presented, featuring Ted Lewis, famous dance exponent and exclusive Columbia artist.

Larson's Dance Orchestra, which is well known in this city, played a selected list of dance numbers at the jazz concert, consisting of selections which are included in the Columbia recording

catalog and which have attained exceptional success. Among the "hits" that were enthusiastically received were "All by Myself," which was featured in the window display; "Mon Homme," "St. Louis Blues," "Wang Wang Blues" and "Oh Me, Oh My." The concert was planned and directed by H. Doyer, of the Dreibelbis Music Shop, who was congratulated upon the success of the event.

THE GO-GETTER'S LULLABY

Someone had said that it couldn't be done,
And he, with a chuckle replied
That "maybe it couldn't" but he would be one
Who wouldn't say so till he tried.
And so with a trace of a grin on his face
(And if he worried he hid it)
He started to sing as he tackled the thing
That couldn't be done—and he did it.

There are thousands to tell you it cannot be done;
There are thousands to prophesy failure;
There are thousands to point out to you, one by one,
The dangers that wait to assail you;
But just huckle in with a hit of grin,
And take off your coat and go to it;
Start in to sing as you tackle the thing
That "cannot be done"—and you'll do it!

CALLING ON THE TRADE

R. M. Kempton, manager of the Vocalion wholesale department of the Aeolian Co., New York, is calling on Vocalion dealers in the Middle West and South.

The T. P. Mercantile Co., of Biloxi, Miss., has installed a new Victrola department. C. W. Baker has been made manager.

"Does It Play All Records?"

Certainly MAGNOLA does; and without any extra attachments, too. This is only one feature, albeit a most important one, in the thoroughly up-to-date equipment of the MARVELOUS MAGNOLA.

MAGNOLA "Built by Tone Specialists"



May we send you our handsome illustrated catalog chock full of information concerning the wonderful construction system of Magnola and the beauties of its musical results, its artistic appearance and its moderate price?

Send your name and let us tell you more!

MAGNOLA TALKING MACHINE COMPANY

OTTO SCHULZ, President

General Office Southern Wholesale Branch
711 MILWAUKEE AVENUE 1530 CANDLER BLDG.
CHICAGO ATLANTA, GA.



EUROPEAN HEADQUARTERS

2 GRESHAM BLDG., BASINGHALL ST., E.C. LONDON

W. LIONEL STURDY, MANAGER

Despite Disturbed Economic Conditions a Decided Betterment Is Evident in the Gramophone and Record Trade—The Question of Overstock One of Great Concern—The Situation Analyzed—Gramophone Co.'s Trading Report—Innovation at Harrod's Stores—"Velvet-face" Records to Be Introduced—Solving Packing Case Problem—St. Hilda Band Wins Test Piece—Sterno Activities—Some News of the Federation of British Industries—"His Master's Voice" Record Prices—Other News

LONDON, E. C., November 1.—With men in their hundreds of thousands clamoring for work, it seems almost paradoxical to infer that musical instruments and other things that do not really come within the category of actual necessities are again in demand. But such is the case. Gramophone and record sales have shown a distinct improvement during the last few weeks. The amount of trade is not by any means what it should be at this period of year, and we have really experienced such a lean time for twelve months or more that, while in some respects a comparison is all to the good, we must not be lulled into any feeling of security when, as is the case to-day, a bigger effort than ever is necessary to maintain any definite standard of business.

On the other side of the picture there are men who believe that the present trade improvement is but spasmodic, a temporary jump that is not justified in accordance with the measure of social and commercial unsettlement throughout the world. This school of thought would have us believe, too, that despite all the strenuous efforts

now being made to enliven and maintain trade, it will not result in any lasting benefit so long as the country is burdened with the deadweight upkeep of a huge army of unemployed. That is a cause which the British Government is trying to mitigate and remove as quickly as may be.

We shall remove the effects of the cause of bad trade just as quickly as we can remove that canker of pessimism which permits a man to lose his spirit and will for work. It's easier to give in than to fight on. In the majority of cases the problems of finance, slackness of trade, manufacturing and other business difficulties rest for their solution almost entirely upon the good will and strength of man's determination. There is always a way out, and, as I have so often said in these columns, individual effort pushed to its utmost triumphs in the end. Our little gramophone industry has really stood the test well. Its history of difficulties during the last year has been tremendous. Yet few firms have gone under. Mutual co-operation has saved the day and there are better times ahead so long as we keep together and exercise that spirit not to give in.

The fact is that trade is on the move; there is, if gradual, an all-round improvement industrially and men are getting back to work in their thousands every week. Labor and the costs of materials are easier. Retail prices for machines and records must work along the same lines and in quite a number of cases big price cuts have already been announced by the chief firms. It is for the dealer, figuratively speaking, to get out and tell the public the good news. Publicity is the keynote of trade to-day as never before.

One difficulty dealers are bothering about just now is the question of overstock. This applies more particularly to records, of which, owing to the trade depression, retailers find their shelves somewhat too full. Much of this stock is fairly old—old in the sense that many of the titles are of that ephemeral order quickly out of demand. As records they are worth the cost of the material and that is all. What is to be done about it? The manufacturer is often pleased to think the question is answered by introducing an exchange scheme by which a new, up-to-date record is given free in exchange for an old record, provided the dealer orders against each such exchange either one or two other records—usually the latter number. By this scheme the dealer who is overloaded with, say, 100 unsalable records has to find room for an additional 200 and perhaps tie up new capital. There are arguments for and against, of course, but for the general run of dealers it is not a good scheme. And the more so at this post-war stage when non-salable stocks are bigger than is usual at normal. The Retail Gramophone Dealers' Association is known to be in negotiation with the record manufacturers on this very point. Admittedly, the problem is not easy of solution to the satisfaction of all parties concerned, but their good sense will surely find a happy way out. For the future a standard scheme is immediately necessary. Dead stock leads to all sorts of evils, notably price-cutting. Manufacturers must therefore, in their own interests, arrive at a business understanding to relieve dealers of the records which in a reasonable time prove unsalable.



"His Master's Voice"

Copyright

This intensely human picture stands for all that is best in music

—it is the "His Master's Voice" trade-mark, and it brings to you, no matter where you are, the very best music of every kind, sung and played by the world's greatest artists—the greatest singers, pianists, violinists, orchestras and bands—all enshrined in the unequalled "His Master's Voice" records

'His Master's Voice'

—the trade-mark that is recognized throughout the world as the

HALL-MARK OF QUALITY

DENMARK: Skandinavisk Grammophon-Aktielselskab, Frihavnen, Copenhagen.

FRANCE: Cie. Française du Gramophone, 115 Boulevard Richard Lenoir, Place de la République, Paris.

SPAIN: Compañía del Gramófono, 56-58 Balmes, Barcelona.

SWEDEN: Skandinaviska Grammophon-Aktiebolaget, Drottning Gatan No. 47, Stockholm.

RUSSIA: The Gramophone Co., Ltd., 45, Nevsky Prospect, Petrograd (Petersburg); No. 1 Solynka, Solynol Dvor, Moscow; 9, Golovinsky Prospect, Tiflis; Nowy-Swiat 30, Warsaw; 11 Michailovskaya Ulitsa, Baku.

INDIA: The Gramophone Co., Ltd., 139, Balliaghatta Road, Calcutta; 7, Bell Lane, Fort, Bombay.

Great Britain:

The Gramophone Company, Ltd.

HAYES

MIDDLESEX

ENGLAND

AUSTRALIA: S. Hoffnung & Co., Ltd., Sole Concessionaries of The Gramophone Company, Limited, 163, Pitt Street, Sydney.

NEW ZEALAND: Gramophonum, Ltd., 118-120 Victoria Street, Wellington.

SOUTH AFRICA: Darter & Sons, Post Box 174, Capetown; Mackay Bros., Post Box 251, Johannesburg; Mackay Bros. & McMahon, Post Box 419, Durban; Ivan H. Haarburger, Post Box 105, Bloemfontein; Franz Moeller, Post Box 108, East London; B. J. Ewins & Co., Post Box 86, Queenstown; Handel House, Kimberley; Laurence & Cope, Post Box 132, Bulawayo; The Argus Co., Salisbury.

EAST AFRICA: Bayley & Co., Lourenço Marques.

HOLLAND: American Import Co., 22a, Amsterdam Veerkade, The Hague.

ITALY: A. Bossi & Co., Via Orefici 2, Milan.

EGYPT (Also for the Soudan, Greece and the Ottoman Empire): K. Fr. Vogel, Post Box 414, Alexandria.



YE "POPULAR" RECORDS

Double-Sided
Superb Needle Cut "10 Inch"
"Lateral"

LONDON'S LEADING VALUE!!!

QUOTATIONS

LOWEST in ENGLAND

FOR "HIGH GRADE PRODUCTS"

5,000 Lots and up "Your Selection" or a Sample 1,000, made up with "One Example" from Catalogued Pairings.

Address: **SOUND RECORDING CO., Ltd.** CABLES "Grammavox"
EXPORT DEPT., 18-19 Swallow Street London
Piccadilly, London, England "QUOTATIONS CABLED FREE"

POINTS We can give customers their own design label for large parcels or deal with any proposition for supplying master records, material or plant.

- ➔ Repertoire Approx 3,000 Titles—Covering
- ➔ Superb Selection, Bands and Orchestral
- ➔ Lightning Shipments
- ➔ Packing by Experts
- ➔ Rock Quotations "Always"
- ➔ F. O. B. London
- ➔ We attend to all Insurances "if Requested" to Buyers A/c
- ➔ Our Shipping Services, this Side FREE
- ➔ Correspondence invited—any language

FROM OUR LONDON HEADQUARTERS—(Continued from page 184)

"His Master's Voice" Report on Year's Trade

No better (or worse) illustration of the great trade slump could be found than the reports just issued bearing on the Gramophone Co.'s business for the year ended June 30 last. It shows a very heavy decline, which, in view of the general depression and unemployment, is perhaps not surprising. The trading profit amounts to no more than £26,119, as against £150,962 for the preceding year. An immediate consequence of this report was a decline in the value of the £1 shares from 23/6 to 15/6, which, however, at the time of writing, are fluctuating favorably. The directors of the company have decided to transfer to profit and loss account a sum of £46,048 previously set aside to war contingency fund, and to draw £50,000 from the reserve for the equalization of dividends. Including the amount brought in and deducting debenture charges, preference dividend, etc., a balance remains of £128,453, out of which it is proposed to pay a dividend of 6 per cent on the ordinary shares, as against 15 per cent last year.

Since the issue of its report gramophone trade has shown a distinct improvement all around. In particular, the "His Master's Voice" business has favorably responded, and if judged by present standards I believe that next year's report covering the period to June 30, 1922, will show a remarkably good trade recovery.

Brief Paragraphs of Trade Interest

The Kentucky song whistle is becoming somewhat of a vogue here. The fact that no great knowledge of music is necessary to play it means perhaps a wider field of sales. In many new orchestral records it has been used with good effect.

With the issue on records of the complete opera "Patience," "His Master's Voice" Co. has covered no less than five of the famous Gilbert and Sullivan works. By the rush to book seats at the Prince's Theatre, London, where the Savoy opera season has just commenced, it would seem that the public is as much in love as ever with these delightful inspirations.

An Aeolian machine and electric "Motophon" accompany Sir Ernest Shackleton on the "Quest" to the polar regions.

It is reported that an invention exists whereby twelve records of the disc type can automatically be played one after the other. There should be a big demand for such a gramophone, though I have heard it said by some folks that one record at a time is quite enough.

The London Music Trades Review reports the discovery of a new material called Ebonite for gramophone horns. It can be cast to any size or shape for exterior or interior sound chambers and is spoken of as an improvement on metal or wood.

A Complete Fiber Needle Outfit

To meet the expansion of trade in fiber needles, and their use is certainly very popular on this side, a new outfit has been marketed by the Gramophone Exchange, of New Oxford

street, London. It consists of a very simple but efficient cutter, a fiber needle adaptor for any make of sound box, and a supply of fiber needles. The complete outfit retails here at the nominal price of 7/6. The "Astra," as it is called, represents a very useful combination, the best yet introduced as a complete outfit on this market.

A Sixpenny Record

Woolworth's stores, with branches all over the country, are selling a small-size record at the nominal price of sixpence. It is the product of a well-known firm and, though in no sense can the record be regarded as in competition with the quality of the standard makes, the fact remains that it is in great demand as a novelty entertainment stunt.

Dancing to the Gramophone at Harrod's

At the great Harrod's Stores an innovation to speed the sale of dance records is announced. Every afternoon in the music salon the "His Master's Voice" dance numbers are demonstrated to the accompaniment of exhibitions of the latest dances by Miss Peggy Carlisle and her partner, Nigel Jessop. So popular has the scheme proved that people are turned away daily. From the sales viewpoint Messrs. Harrod's are well pleased.

Gramophone Supersedes the Piano

The way to advertise is shown by Thos. Edens Osborne, of Belfast, Ireland. One of his chatty ads reads: "Evidently the piano is being rapidly

superseded by the gramophone and ladies are purchasing records of popular songs, dances, etc., in order to introduce pleasant surprises on their 'At Home' evenings." These ads appear in local journals of repute and, being of the editorial style, make good reading.

Edison Bell and Winner News Items

An increase in record sales at this period of the year is only to be expected. But to this alone cannot be ascribed the big trade improvement noted by J. E. Hough, Ltd. It is also due to the reduction to 2/6 of the price of Winner records, and equally so to the wide field covered in the compilation of regular monthly programs of new records of the popular type. Apart from the home trade foreign business shows gradual improvement, and I learn that the Peckham plant is steadily busy at this time.

By the way, Percy Willis, sales manager, informs me that his firm will shortly introduce a new series of records under the label "Velvet-Face" in ten- and twelve-inch sizes. The name implies a velvet surface, obtained, I understand, by a special process in the manufacturing. That will disclose itself in due course. As regards titles and artists, the company's present intention is to run a somewhat exclusive standard embracing music and song of the higher degree recorded by appropriate artists. This is certainly a wise step—in conformity with the increasing appreciation of the educative value of the gramophone. It is progressive, uplifting to

(Continued on page 186)

"PERFECT POINTS"

BRITAIN'S BEST

Gramophone Needle

(Guaranteed made from High Carbon Steel)

IS MADE BY

W. R. STEEL, of REDDITCH,

Head Office and Works—QUEEN ST.

Scientifically pointed, Hardened and Tempered on the latest up-to-date machinery and plant by skilled craftsmen only.

RESULT:

A FIRST QUALITY NEEDLE far ahead of anything of pre-war quality

INQUIRIES SOLICITED

Special Quotations for Quantities

Manufacturer of all Kinds of Sewing Needles

Horn, Hornless and Table-Grand GRAMOPHONES

FOR
EXPORT

Please State Your Requirements

REX GRAMOPHONE CO. 2 Elizabeth Place
Rivington Street, LONDON, E.C. 2, England
Cable Address "Lyrecodisc, London"

the status of our trade, and as such merits the active support of all having interest in the development of gramophonic art and industry.

An Effort to Solve the Packing Case Difficulty

The Gramophone Co. has inaugurated a new scheme with regard to the return of empties. In many instances packing cases have been returned in such a bad condition as to be useless, and often they go astray in transit. This is a thorny question that bothers all our manufacturers. If it proves in practice a solution the new plan of the Gramophone Co. will doubtless be followed by other firms. And the plan is that the company will carry the bulk of the cost of all packing cases, merely charging dealers a very nominal figure, on the basis that all cases will in future not be returnable. At the prices charged dealers should be able to dispose of the cases at, if anything, a profit. On the face of it the new arrangement should prove acceptable.

The "His Master's Voice" Special News Items

An important announcement issued to dealers by the above company may now be made public. From October 17 the price of Plum label records are 4/-, ten-inch; 6/-, twelve-inch; and for the Black label, ten-inch, 5/6; twelve-inch, 7/6. As will be noted, these price reductions apply to what may be termed the popular labels, which, in consequence, will certainly enjoy a wider demand than ever.

Early advice has been given to all "His Master's Voice" dealers, in order that they may clear stocks of no less than 490 records, which are to be deleted from the company's Spring (1922)

FROM OUR LONDON HEADQUARTERS—(Continued from page 185)

edition catalog. With this advance notice dealers should have plenty of time to sell out on these numbers if they want to clear their shelves for up-to-date issues.

The great Chaliapine, who is now in America, made a number of records before his departure from London. These records are, of course, exclusively H. M. V. His two "Boris" records are being sold by the company for the benefit of the Russian Famine Relief Fund. That is, during the period October 1 to December 31 the whole profit on the sales of these two records will be handed over to the fund. It will be interesting to know the amount.

Effective Publicity Matter Issued by Pathé

Of late Pathé Frères have made notable advance in the quality and quantity of their trade publicity literature. This is very helpful to the dealer who is out to create sales by a wise distribution of record lists and the display of window streamers, etc. Recent issues include a new list of Hawaiian records, record catalog complete to date, leaflets re sound boxes, and much other useful sales literature.

The new Pathé needle-cut Actuelle record has been very favorably received and good orders placed by the trade.

Another Grand Championship Test Piece

For the third time since 1912 the St. Hilda Colliery Band has carried off the Grand Championship for the best rendition of a set test piece. The contest was held at the Crystal Palace, S. E. London, and twenty-one bands competed. In turn they each played what is regarded as the most difficult test piece ever set in a national competition—"Life Divine," an exquisite tone poem by Cyril Jenkins. The judges were locked in a room, guarded by the police from all interference.

As was the case last year, the British Zonophone Co. again secured the exclusive services of the St. Hilda Colliery Band for recording the winning item under the personal conductorship

of the composer. The record is No. 2168, and a fine one it is, too!

With the reduction in the price of Zonophone records to 3/- sales have increased enormously. Some fine selling titles figure in the current list. No. 2156, "Inagination Waltz" and "Amazon," two more tuneful items by the Black Diamond Band. "Amazon" also figures as a vocal by Herbert Payne. It is of the pathetic strain and is rather a difficult song to sing. Mr. Payne gives a good rendition, though, as also of "The Lisp of a Baby's Prayer," on 2161. A good selling record should be 2160, "Silver Star," which is most naturally sung by Robert Woodville, and "Sweet and Low" by the same artist. Sydney Collham contributes two of his ever-acceptable tenor songs on 2159—"Only You" and "Forever and Forever." A really magnificent piccolo recording by Geo. Walker (with piano) is on 2166—"The Mocking Bird" and "Slump," a piccolo rag of striking effect. Jack Hylton's Jazz Band gives itself over to riotous behavior in its playing of "Billy" and "Wang Wang Blues," two goodly numbers deserving of the band's remarkable efforts.

The Phonogram Year Book, 1922

There are close upon twenty gramophone and phonogram societies active in the United Kingdom. That means a membership of approximately 1,000 real enthusiasts—men, and ladies, too, who pay fitting homage to the study of mechanically produced music. It is a growing movement and one that should be encouraged still more than it is by manufacturers.

W. J. W. Hamill, one of the originators of the society movement, believes that it should now be represented by its own organ of intelligence and has made a start by the issue of "The Phonogram Year Book and Talking Machine Society Guide." It is an encyclopedic little book which should serve as a reliable reference upon all matters appertaining to the society movement in this country. Many who take a leading part in

Grippa Portable Gramophone

(Patents pending all countries)

Marketed in Great Britain less than three months ago, it has leapt into popularity with amazing rapidity. The most perfect manufacturing and selling proposition in the Gramophone World.

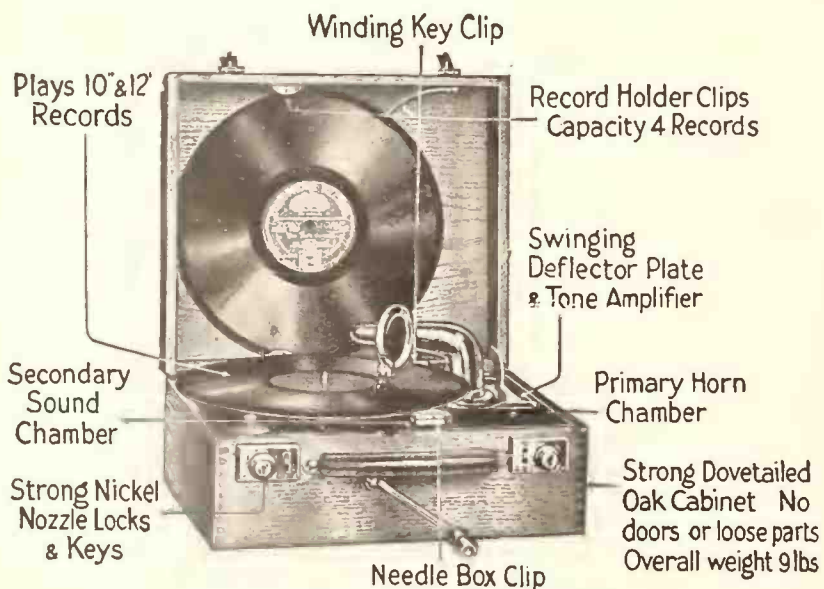

1. Perfect tone reproduction equal to a cabinet model.
2. Travel proof and fool proof.
3. Extraordinary low factory costs.

Model 3, as sketch, produced, sold and delivered to the retailer—Hence to the public at eighteen dollars. Showing full manufacturers' and jobbers' profits.

Exclusive manufacturing rights under royalty—apply to maker and patentee

H. J. CULLUM, Manager-Director

PEROPHONE, Limited, 76-78 City Road, London, England

EDISON BELL

WINNER
 TRADE MARK
 GRAMOPHONE RECORDS
CABLE
"PHONOKINO,
LONDON"

ARE THE GREATEST VALUE FOR MONEY PRODUCED IN GREAT BRITAIN

TEN INCH

DOUBLE SIDED

NEEDLE CUT

PLAY ON ALL GRAMOPHONES

Catalogue contains 4000 Titles by the Premier Artistes, Instrumentalists, Orchestras and Bands
of the British Empire

DEALERS PREPARED TO DO BUSINESS ARE INVITED TO COMMUNICATE WITH

Proprietors and Manufacturers, J. E. HOUGH, Ltd., 62 Glengall Road, London, S. E. 15, England

FROM OUR LONDON HEADQUARTERS—(Continued from page 186)

the official side of the society work have contributed articles and advice which the reader of the Phonogram Year Book will peruse with interest. Of special value, too, is the list of societies, their places and times of meeting, officials and other useful information, with a short history of each. The book is published at 9/-. I heartily congratulate Mr. Hamill upon its issue. Copies may be obtained from him, at 3 Curzon road, Higher Broughton, Manchester.

Some Good Salable Sterno Lines

Dealers abroad would do well to keep track of the new goods so frequently issued by the Sterno Mfg. Co., City Road, London. Previous reference has been made to the "Elektromophon," a fine piece of electric mechanism for high-class machines. When mounted in the cabinet this motor is really noiseless, and noticeable, too, is entire absence of vibration. Its equipment includes an automatic stop electrically controlled. The "Elektromophon," fully described in a recent report from this office, will run on any voltage. It has interested the trade here and evoked high praise.

Another line by this company is the "Homochord" record, ten-inch double side, of which a big first list has just been announced. A fine

repertoire it is—many popular standard works by old masters, operatic and, of course, sentimental with a fair leavening of humorous records. The records are of good quality and will satisfy the most critical. Special mention should be made of the Homochord jazz issues. These are quite new numbers from the States, of real color—if anything, superior to the usual blatancy of jazz music. The Sterno people are evidently out to offer the British trade a better phase of this type of music, and in the records played over to me I think they have secured something which will win our dealers' approval.

Federation of British Music Industries News

At a recent meeting of the Federation Louis Sterling was elected to the post of chairman, succeeding Alexander Dow, who was desirous of retiring from that position. R. W. Pentland and A. J. Mason were re-elected deputy chairmen and William Rushworth honorary treasurer. Mr. Dow was elected honorary vice-president in recognition of his valuable services to the Federation. His address, as well as that of the new chairman, was listened to with great interest.

It was announced that eight Provincial papers were added to the list of journals accepting the

Federation's weekly articles on music. A consultative committee of prominent musicians to advise the Federation on musical and educational matters is now being formed. Sir Henry Hadow, Sir Alexander Mackenzie, Lt. Col. Stretton, Frank Roscoe and Robert McLeod have consented to serve.

In connection with the British Industries Fair to be held next year, arrangements have been made for the housing of the music section in one of the buildings. In this connection efforts are being made to have space at the fair allotted only to genuine British goods. This is somewhat of a difficult task, inasmuch as many instruments are imported in whole or in part and assembled in England, thus masquerading under the title of "British made."

KIMBALL CONSOLES IN DEMAND

Console model talking machines are in greater demand each month, reports the W. W. Kimball Co., of Chicago. People with a knowledge of music and of refinement are choosing this model in preference to others, not only for its musical qualities but for its artistic appearance, which makes it a valuable addition to home ornament.

You Ought to Know

In case you are contemplating expanding the sphere of your business to include departments devoted to Pianos, Player-Pianos, Musical Merchandise or Sheet Music, that you'll find news and comments about them all in



ESTABLISHED 1876

The oldest and leading music trade weekly, which covers every branch of the industry

It Contains

Instructive and educational articles. Hints on salesmanship and advertising. Editorials that are timely and authoritative. Facts about the new things in the trade. Trade happenings in all parts of the United States

"Review the Music Trade With Us"

Send your \$2 now for a full year's subscription to

THE MUSIC TRADE REVIEW
373 FOURTH AVENUE NEW YORK

LATEST PATENTS RELATING TO TALKING MACHINES AND RECORDS

WASHINGTON, D. C., November 8.—Talking Machine. Joseph Wolff, Brooklyn, N. Y., assignor to the Sonora Phonograph Co., New York. Patent No. 1,387,575.

The main objects of this invention are to provide a talking machine with a continuous wooden sound amplifier of relatively great efficiency; to provide an improved sound amplifier constructed entirely of wood, thereby transmitting the sound waves from the sound box through a continuous wooden passage to the atmosphere, thereby increasing the sonority, brilliancy and other good qualities in sounds; and entirely eliminating the "brassy" or metallic sound so prevalent in talking machines; and giving a wonderfully clear, brilliant, broad and mellow quality to the reproduction; to provide a wooden tone arm constructed as hereinafter described, which will do away with the mechanical, harsh and metallic sounds produced in the operation of talking machines; and to produce a full, even and continuous volume of sound in which the articulation is clear, full and distinct; a further object being to provide a tone arm of the class specified which is made entirely of wood or other fibrous material, as hereinafter described; to provide a horn of wood or other fibrous material, constructed as hereinafter described, and to be so constructed that it shall have unexcelled acoustic properties, and to increase the volume and purity of the tone produced.

In the drawings Figure 1 is a side elevation, partly in section, of a talking machine cabinet having a talking machine provided with a wooden sound amplifier, and other details constructed in accordance with this invention; Fig. 2 is a perspective view of a wooden tone arm constructed in accordance with one embodiment of this invention; Fig. 3 is a view of the tone arm, partly in section, taken on the line 3—3 of Fig. 2; Fig. 4 is a perspective view of the preferred embodiment of the horn construction; Fig. 5 is a fragmentary sectional view showing the construction of the veneering of embodiment of Fig. 4; Fig. 6 is a modified form of the horn construction; Fig. 7 is another modified form of the horn construction; Figs. 8 and 9 illustrate perspective views of a tone arm constructed of a plurality of veneers or veneered material; Fig. 10 is a further modification of the horn construction; Fig. 11 is a front view of the modification illustrated

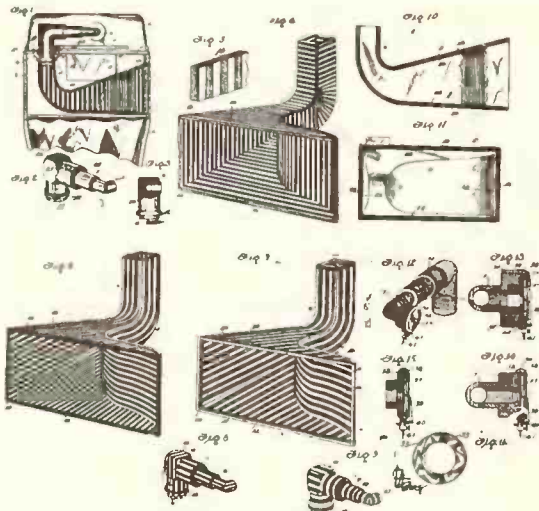

in Fig. 10; Fig. 12 is a perspective view of another modification of the improved tone arm; Fig. 13 is a sectional view of a tone arm and sound box; Fig. 14 is another modification of the combined tone arm and sound box construction; Fig. 15 is a sectional view of the improved sound box; Fig. 16 is a view showing the arrangement of the veneerings in Fig. 12.

Talking Machine. Jobby Belpedio, Bridgeport, Conn. Patent No. 1,389,478.

This invention has for its principal object to provide a combination brake and disc elevator which is arranged in such a manner that when the tone arm is moved to a predetermined posi-

tion the record tablet or disc will be elevated above the top of the turntable to permit the ready removal of the same.

Another object of the invention resides in the provision of a lever adapted to be attached to the tone arm in such a position that when the tone arm is moved to the extreme right the brake and elevating mechanism will be automatically operated.

Figure 1 is a top plan view of a talking machine illustrating the elevating means on the turntable; Fig. 2 is a view similar to Fig. 1, showing the turntable removed to more clearly illustrate the details of construction; Fig. 3 is a

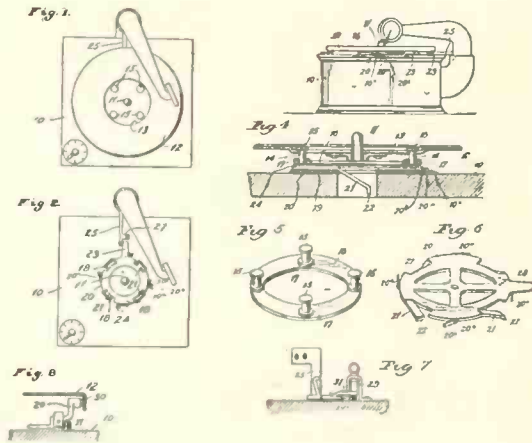

side view of Fig. 1; Fig. 4 is a fragmentary enlarged sectional view through the device; Fig. 5 is a perspective view of the elevating means; Fig. 6 is a perspective view of the cam ring; Fig. 7 is a fragmentary enlarged sectional view through a portion of the table, illustrating the brake in detail, and Fig. 8 is a view taken at right angles to Fig. 7.

Recording and Reproducing Attachment for Phonographs. Willard H. Gilman, New York, assignor to John A. McVickar, same place. Patent No. 1,389,429.

This invention relates to phonographs and particularly to an attachment for disc type phonographs which includes a mechanism whereby the records may be recorded and reproduced on any standard disc type phonograph. The objects of this invention are to provide a mechanism of this kind which is readily detachable and replaceable; which takes care of irregular movements of the turntable and the turntable stem; which provides for adjustments for different sizes of machines; which may be raised and turned back from the turntable while the latter is in motion and may be replaced while it is in motion; which permits the horn to be turned in any direction without disturbing the mechanism or the position of the phonograph; which automatically raises the stylus from the record when the machine has moved to a predetermined position and which includes means for raising and lowering the

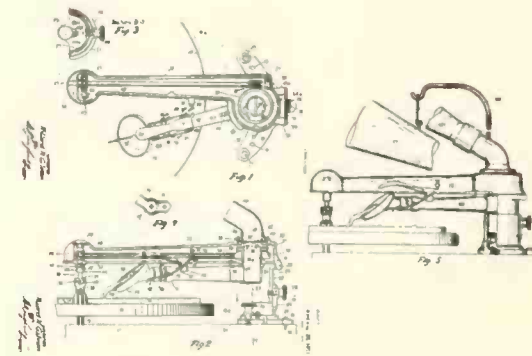

stylus and diaphragm head as may be desired. Other objects will appear from the drawings, in which Figure 1 is a plan view with the mechanism case in section; Fig. 2 is a vertical elevation in section through the center line of the mechanism; Fig. 3 is a detail of the support on line a—a, Fig. 2; Fig. 4 is a detail of the voice tube, and Fig. 5 shows a vertical elevation of the device complete.

Phonograph. John H. Anderson, Chicago, Ill. Patent No. 1,389,089.

The objects of this invention are to provide an improved phonograph wherein access to the interior of the cabinet and the motor, may be readily obtained; also wherein the horn is supported independently of the motor, turntable and tone arm.

Figure 1 is an elevation of the phonograph structure showing parts in section; Fig. 2 is a

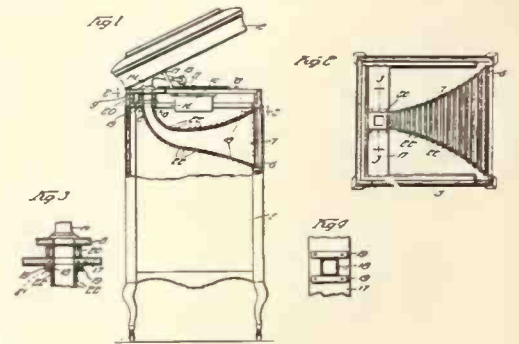

transverse section taken on line 2—2 of Fig. 1; Fig. 3 is a section taken on line 3—3 of Fig. 2; Fig. 4 is a section taken on line 4—4 of Fig. 1.

Phonograph. James T. Leitch, Allentown, Pa. Patent No. 1,389,058.

This invention relates to an improved sound box for phonographs which is termed an "articulator." The object of the invention is to provide an improved general construction of phonograph sound box having a resonator of novel construction whereby increased amplitude of vibration of the sound waves will be obtained and the absorption and consequent waste of sound-producing vibrations be eliminated. Other objects are an improved arrangement of needle arm and its bracket or support therefor in order to prevent damping of vibrations by absorption in the body of the sound box as well as to eliminate the production of metallic effects, and a novel amplifier so connected with the resonator that the produced vibrations will be collected and amplified.

Figure 1 is a front or face view of the improved reproducer; Fig. 2 is a side view thereof; Fig. 3 is a back view thereof; Fig. 4 is an end

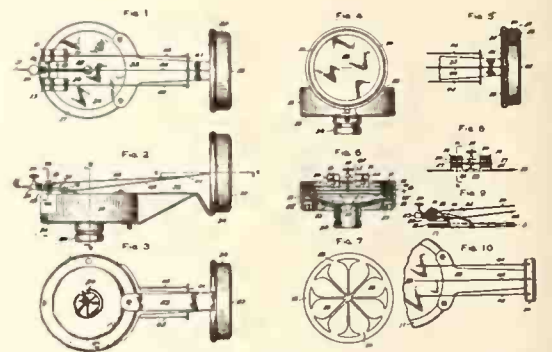

view taken from the right-hand side of Fig. 1; Fig. 5 is a detail section on the line V—V of Fig. 2; Fig. 6 is a section on the line VI—VI of Fig. 2; Fig. 7 is a detail showing the perforated diaphragm removed from the box; Fig. 8 is a detail section on the line VIII—VIII of Fig. 2; Fig. 9 is a detail section on the line IX—IX of Fig. 8.

Talking Machine. Frank Talarico, Philadelphia, Pa. Patent No. 1,388,980.

One object of this invention is to provide an improved sound conducting and amplifying means which can be easily and quickly placed in operative position on any supporting structure adjacent a record, thereby doing away with the necessity of employing complicated and expensive cabinets and amplifying means such as now commonly employed in connection with talking machines.

Another object is to so construct the device of the invention that it can be easily manipulated so as to transmit sounds, and when not desired

LATEST PATENTS RELATING TO TALKING MACHINES AND RECORDS—(Continued from page 188)

for use the same can be moved into a position out of the way so as to permit a record to be removed from the turntable and another record placed thereon.

Figure 1 is a side elevation of the invention showing the same in the position which it occupies when playing a record; Fig. 2 is a top plan view of Fig. 1; Fig. 3 is a view of similar character to Fig. 2 showing the device in a position when not in use; Fig. 4 is a sectional elevation

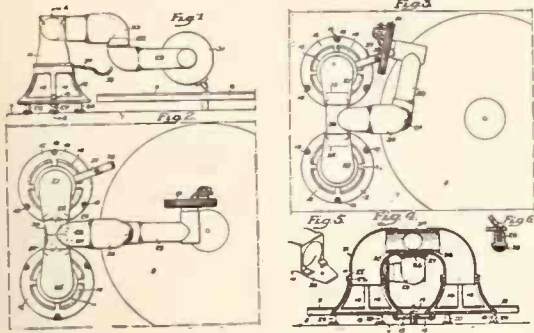

taken on the line 4-4 of Fig. 1; Fig. 5 is a fragmentary perspective view showing a certain feature of construction of a part of the invention, and Fig. 6 is a fragmentary view showing a modification of adjustable means which forms a part of the invention.

Amplifier for Sound-reproducing Machines. Franklin T. Shackelford, Minneapolis, Minn. Patent No. 1,389,999.

This invention relates to improvements in sound-reproducing machines and has more particular reference to a sound amplifier or horn for such machines, and it will evenly diffuse and amplify the sound waves passing therethrough and produce a clear, mellow tone and one which will be true to the original production.

Figure 1 is a vertical sectional view through a portion of a phonograph, showing an amplifier constructed in accordance with this invention applied thereto; Fig. 2 is a horizontal sectional view through the phonograph and amplifier taken on the plane indicated by the line 2-2 of Fig. 1; Fig. 3 is a front view of the amplifier detached

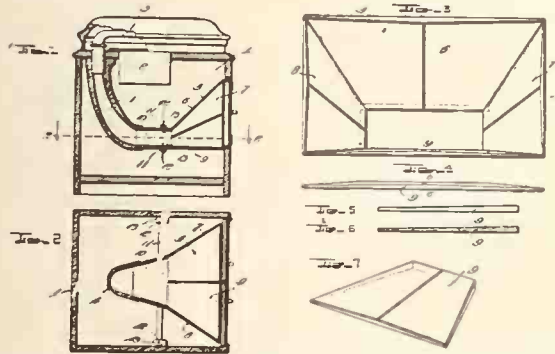

from the phonograph; Fig. 4 is a front edge view of the bottom of the amplifier; Fig. 5 is a side edge view of the bottom of the amplifier; Fig. 6 is a longitudinal sectional view of the bottom of the amplifier taken on the plane indicated by the line 6-6 of Fig. 4, and Fig. 7 is a perspective view of the bottom of the amplifier.

Stylus Holders for Talking Machines. Frank D. Lewis, West Orange, N. J., assignor to the Pathé Frères Phonograph Co., Brooklyn, N. Y. Patent No. 1,389,885 and Patent No. 1,389,886.

The first-named patent relates to improvements in stylus holders for talking machines, and in particular for talking machines of the Actuelle type as disclosed generally in Letters Patent No. 1,271,527, granted to Marcus C. Hopkins.

It is the object of the present invention to overcome the objection previously held by equipping the swinging arm with two separate and distinct stylus holders of different leverages, which are interchangeably brought into playing position by a rotation of the arm in the proper direction. The stylus holder now employed in the commercial Actuelle is utilized in connection with the playing of vertical-cut records, and hence receives the usual jewel-point stylus; and to this holder there is connected a second holder which receives the needle or stylus used for playing lateral-cut records. The second stylus holder is, or may be, mounted on the cap at the front end of the swinging arm, and its vibrations are transmitted to the first holder through its connection therewith, and thence, through the transmission device, to the diaphragm. The two holders are so arranged with relation to each other that a rotation of the arm through approximately 180 degrees is necessary to shift either holder out of working position and simultaneously bring the other into such position.

In the drawing Figure 1 is a part-sectional side elevation of a Hopkins-type diaphragm and its carrier arm, the latter being equipped with the improved stylus holder construction; Fig. 2 is an enlarged side view of the front end of the carrier arm and attached parts, showing the playing position for lateral-cut records; Fig. 3 is a front view of Fig. 2; Fig. 4 is an enlarged cross-section on line 4-4, Fig. 1.

The second-named patent relates to stylus holders for talking machines, and in particular for talking machines of the Actuelle type as disclosed generally in Letters Patent No. 1,271,527, granted July 2, 1918, to Marcus C. Hopkins.

It is the object of the present invention to eliminate the rotary movement of the swinging arm, and particularly of the diaphragm, both for the purpose of simplifying the former construction and its mode of adjustment, and in order to avoid the liability of the diaphragm being grasped and turned to effect the desired adjustment, with possible resultant injury to the diaphragm. Accordingly here is devised a construction in which, instead of the carrier arm and diaphragm being rotatable, those parts are relatively motionless, the sole adjustable or rotatable part being a cap or equivalent part which is connected to the end of the arm and to which the stylus holder is attached. The latter does not immediately vibrate the main transmission device, but, instead, actuates an intermediate or auxiliary device which is connected to vibrate the main device; the connection between the two vibration-transmitting devices preferably consisting of a bell-crank lever, to whose arms the ends of said devices are attached. The main transmission device—that is to say, the device utilized

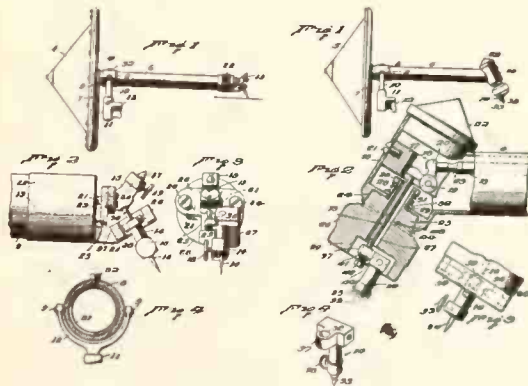

in the commercial Actuelle—is left unchanged in so far as its construction, arrangement and function are concerned, so that the installation of this invention may be effected readily and with but little alteration or modification of parts.

In the drawing Figure 1 is a side elevation of a Hopkins-type diaphragm and its carrier arm, the latter being equipped with the improved stylus holder; Fig. 2 is an enlarged longitudinal sectional view of the front end of the carrier arm and attached parts, showing the playing position for Pathé or vertical-cut records; Fig. 3 is a view generally similar to Fig. 2, but showing the parts in position for playing lateral-

cut records; Fig. 4 is a detail view of the stylus holder.

Sound Box. George A. Moore, Medford, Mass. Patent No. 1,389,683.

This invention has for its object the construction of improved means for pivotally supporting the needle arm of a talking machine sound box.

To this end, the needle arm is clamped to a diaphragm supported at right angles to the plane of the resonator diaphragm, and provides means whereby the clamping device can be shifted in the plane of its diaphragm in order that the point of the needle arm's attachment to the resonator diaphragm may be entirely neutral thereto; in other words, that it may have no tension thereon in either direction.

In the drawings forming part of this specification Figure 1 is a face view of a sound box embodying the improvements; Fig. 2 is a view of the same looking in the line of its stylus; Fig. 3 is a central sectional view of the same; Fig. 4 is a view similar to that in Fig. 2, but

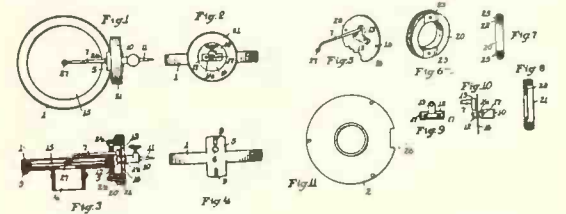

with certain parts removed; Fig. 5 is a perspective view of a portion of the needle arm and its supporting diaphragm; Fig. 6 is a perspective view of the threaded annulus composing a part of the clamping means for the supporting diaphragm; Fig. 7 is a sectional view of the same; Fig. 8 is a sectional view of the other member of the clamping means; Fig. 9 is a view of one of the cross arms between which the supporting diaphragm is fastened; Fig. 10 is an edge view of the supporting diaphragm showing the cross arms of the needle arm attached thereto; Fig. 11 is a face view of the back plate of the sound box.

Needle Adjusting Means. Forest Cheney, Chicago, Ill., assignor to the Cheney Talking Machine Co., same place. Patent No. 1,390,499.

The present invention resides in an improved needle positioning device by means of which the sound box may be conveniently supported to discharge the used needle into an adjacent receptacle and then moved upon its support into the proper position to permit the new needle

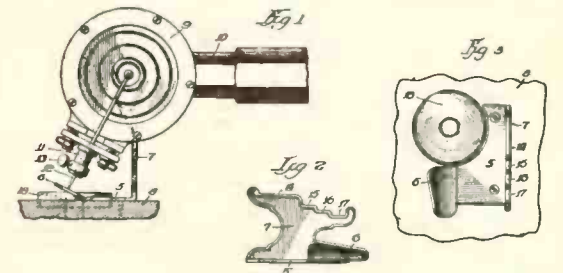

when inserted in its holder to project from the sound box a greater or less degree according to the sound volume desired.

Figure 1 shows an elevation of a sound box having a breech-loading needle-holder positioned to be used with the adjuster; Fig. 2 is an elevational view of the adjuster looking from the left-hand end of Fig. 1, and Fig. 3 is a top plan view of the adjuster.

Bankers always have based credit on goodwill. But it is only comparatively lately that they have come to know what produced the good-will. The force that produces good-will is advertising. Advertising, therefore, is really one of the fundamentals of credit.

REPAIRS

All Makes of Talking Machines
Repaired Promptly and Efficiently
REPAIR PARTS FOR ALL MACHINES

ANDREW H. DODIN
28 Sixth Avenue New York
TELEPHONE, SPRING 1194

DAMAGED VARNISH

can be permanently and invisibly repaired by using
LESLEY'S PATCHING VARNISH

Price: 1 pt., \$1.00; 1 qt., \$1.90
Complete repair outfit, \$3.50

Write for catalogue

LESLEY'S CHEMICAL CO.

10 S. New Jersey St.

Indianapolis, Ind.

Advance RECORD BULLETINS for December, 1921

VICTOR TALKING MACHINE CO.

POPULAR SONGS

- 18811 You're Just the Type for a Bungalow, Irving Kaufman 10
- Don't Throw Me Down.....Irving Kaufman 10
- 18812 My Sunny Tennessee.....Peerless Quartet 10
- Ain't You Coming Out, Malinda? Peerless Quartet 10
- 18813 Sally, Won't You Come Back?.....John Steel 10
- Bring Back My Blushing Rose.....John Steel 10
- 18821 Kentucky Home, Henry Burr and Peerless Quartet 10
- Who'll Be the Next One (To Cry Over You), Arthur Fields 10
- 18816 Sal-O-May—Fox-trot, Joseph C. Smith and His Orchestra 10
- Why, Dear?—Fox-trot, Joseph C. Smith and His Orchestra 10
- 18823 One Kiss—Fox-trot, The Benson Orchestra of Chicago 10
- Just Like a Rainbow—Fox-trot, The Benson Orchestra of Chicago 10
- 18824 Canadian Capers—Fox-trot, Paul Whiteman and His Orchestra 10
- Bimini Bay—Fox-trot, The Benson Orchestra of Chicago 10
- VOCAL AND INSTRUMENTAL RECORDS
- 45257 The Virgin's Lullaby.....Merle Alcock 10
- An Old Sacred Lullaby, Olive Kline and Lambert Murphy 10
- 35712 Christmas Hymns and Carols—No. 1, Trinity Choir 12
- Christmas Hymns and Carols—No. 2, Trinity Choir 12
- 35711 Santa Claus Visits the Children—Part 1, Gilbert Girard 12
- Santa Claus Visits the Children—Part 2, Gilbert Girard 12
- 45255 Darky Stories.....Walter C. Kelly 10
- Irish Stories.....Walter C. Kelly 10
- 18815 Ross' Dog Trot....."Black Face" Eddie Ross 10
- Ross' Reel....."Black Face" Eddie Ross 10
- RED SEAL RECORDS
- 64996 Swingin' Vine.....Ralph L. Grosvenor 10
- EMILIO DE GOGORZA, *Baritone*
- 64997 Song of the Volga Boatmen..... 10
- MISCHA ELMAN, *Violinist*
- 66008 Canzonetta.....A. d'Ambrosio 10
- AMELITA GALI-CURCI, *Soprano—In French*
- 74718 Les Pêcheurs de Perles—Comme Autrefois (Pearl Fishers—As in Former Times).....Bizet 12
- ORVILLE HARROLD, *Tenor*, and EVA GAUTHIER, *Soprano—In French*
- 74716 Louise—Depuis longtemps j'habitais cette chambre (For a Long Time I Have Occupied This Room).....Charpentier 12
- MARCEL JOURNET, *Bass—In French*
- 74519 Cantique Noël (O Holy Night).....Adolphe Adam 12
- JOHN McCORMACK, *Tenor*, and FRITZ KREISLER, *Violinist* (Piano accompaniment, Edwin Schneider)
- 87576 The Last Hour, Jessie C. Brown and A. Walter Kramer 10
- SERGEI RACHMANINOFF, *Pianist*
- 66007 Valse in G Flat Major.....Chopin 10
- ERNESTINE SCHUMANN-HEINK, *Contralto*
- 87330 Oh Come, All Ye Faithful (Adeste Fideles), Marcos Portugal 10
- TITTA RUFFO, *Baritone—In French*
- 88643 Patrie—Cantabile de Rysoor (Song of Rysoor), Paladihe 12
- ARTURO TOSCANINI and LA SCALA ORCHESTRA
- 64999 Carinen—Aragonaise (Prelude to Act 4).....Bizet 10
- REINALD WERRENATH, *Baritone*
- 74719 Nazareth.....Chorley-Gounod 12

COLUMBIA GRAPHOPHONE CO.

SYMPHONY RECORDS

- A6196 O Come All Ye Faithful—Mezzo Soprano and Male Quartet, Barbara Maurel and Male Quartet 12
- Hark, the Herald Angels Sing—Mezzo Soprano Solo and Male Quartet, Barbara Maurel and Male Quartet 12
- 79891 Then You'll Remember Me (From "The Bohemian Girl")—Tenor Solo.....Charles Hackett 10
- A6198 Mary of Argyle—Soprano Solo, Corinne Rider-Kelsey 12
- My Lovely Celia—Soprano Solo, Corinne Rider-Kelsey 12
- 49968 Carmen, "Conzone del Toreador" (Song of the Toreador)—Baritone Solo and Male Chorus, Riccardo Stracciari and Male Chorus 12
- 79708 Souvenir—Violin Solo.....Duci de Kerekjarto 10
- A6197 Festival Overture, Key of "E" Flat Major, Cincinnati Symphony Orchestra 12
- Under direction of Eugen Ysaye
- Marche Joyeuse, Key of "C", Cincinnati Symphony Orchestra 12
- Under direction of Eugen Ysaye
- A3469 Nearer, My God, To Thee—Male Quartet, Columbia Stellar Quartet 10
- Lead, Kindly Light—Male Quartet, Columbia Stellar Quartet 10
- E7304 Dreams and Fairy-Tale.....Gypsy String Quartet 10
- Flora.....Gypsy String Quartet 10
- A3480 At the Mountain Inn—Violin, flute and harp trio, Stell, Schutze and Heinrich 10
- On the High Alps—Violin Duet, Geo. Stell and Walter Biedermann 10
- A3482 Yoo-Hoo—Fox-trot.....The Happy Six 10
- Fancies—Fox-trot.....The Happy Six 10
- A6199 Why, Dear? (Intro.: "Sweet")—Medley Fox-trot.....The Happy Six 12
- When the Sun Goes Down Blues and Once in a Blue Moon—Medley Fox-trot.....The Happy Six 12
- A3481 My Sunny Tennessee—Fox-trot.....The Columbians 10
- Who'll Be the Next One (To Cry Over You?) (Intro.: "Daddy! Your Mammy's Lonesome for You")—Medley Fox-trot.....The Happy Six 10
- A3478 Sally, Won't You Come Back? (From "Ziegfeld Follies of 1921")—Tenor Solo.....Joe Schenck 10
- Follies of 1921—Tenor Solo.....Joe Schenck 10
- Learn to Smile (From "The O'Brien Girl")—Tenor Solo.....Charles Harrison 10
- A3475 Sweet Lady, from "Tangerine."—Tenor Solo, Frank Crumit 10
- You're Just the Type for a Bungalow—Tenor Solo.....Frank Crumit 10
- A3474 The Memphis Blues, Marion Harris, Comedienne 10
- Beale Street Blues.....Marion Harris, Comedienne 10
- A3476 I Wonder If You Still Care For Me—Male Quartet.....Broadway Quartet 10

- Jealous of You—Tenor Solo.....Charles Harrison 10
- A3479 Nervous Blues (From "Put and Take")—Comedienne and Jazz Band.....Edith Wilson and Johnny Dunn's Original Jazz Hounds 10
- Vampin' Liza Jane (From "Put and Take")—Comedienne and Jazz Band.....Edith Wilson and Johnny Dunn's Original Jazz Hounds 10
- THE MID-MONTH LIST
- A3473 Ma (Intro. "When the Honeymoon Was Over") Medley Fox-trot.....Ted Lewis and His Band 10
- Bimini Bay—Fox-trot.....Ted Lewis and His Band 10
- A3472 Say It With Music (From "The Music Box Revue")—Fox-trot.....The Columbians 10
- Just Like a Rainbow—Fox-trot.....The Columbians 10
- A3470 Canadian Capers (Intro.: "Dreaming")—Medley Fox-trot.....Paul Biese Trio 10
- Dangerous Blues (Intro.: "Sweet Love")—Medley Fox-trot.....Paul Biese Trio 10
- A3471 Saturday.....Nora Bayes, Comedienne 10
- You've Made a Chicken of Your Mother (But You Can't Make a Goose of Me), Nora Bayes, Comedienne 10
- A3477 Dapper Dan—Tenor Solo.....Frank Crumit 10
- Ten Little Fingers and Ten Little Toes (Down in Tennessee)—Tenor Solo.....Irving Kaufman 10
- SPECIAL LIST OF CHRISTMAS RECORDS
- 79373 Holy Night, Peaceful Night.....Jeanne Gordon 10
- A6169 Nazareth.....Seagle & Col. Stel. Quartet 10
- Voice of the Chimes.....Seagle & Col. Stel. Quartet 10
- A2993 Ye Olden Yuletide Hymns.....Columbia Stellar Quartet 10
- A2385 Hark! The Herald Angels Sing.....H. Kopp 10
- Adeste Fideles.....H. Kopp 10
- A2790 The Star of the East.....Maurel & Stellar Quartet 10
- The Birthday of a King.....Barbara Maurel 10
- A2789 Christmas—Pumpkin Center.....Stewart, Jones & Qt. 10
- Evening—Pumpkin Center.....Stewart, Jones & Qt. 10
- A2800 Kiddies Christmas Frolic.....Columbia Orchestra 10
- A2788 Oh! Come All Ye Faithful.....Columbia Stellar Qt. 10
- Hark! The Herald Angels Sing.....Columbia Stellar Qt. 10
- A2392 Medley Christmas Carols.....Columbia Quartet 10
- A2391 Oh! Little Town Bethlehem.....Col. Double Mixed Qt. 10
- White Shepherds Watched.....Col. Double Mixed Qt. 10
- A2801 Silent Night, Hallowed Night.....C. Harrison 10
- Oh! Holy Night.....Harrison and Stellar Quartet 10
- A2644 Christmas Chimes.....Prince's Orchestra 10
- Cathedral Chimes.....Prince's Orchestra 10

AEOLIAN CO.

OPERATIC SELECTIONS

- 30137 Tosca—Radondita armonia (Strange Harmony) (Puccini)—Tenor (in Italian), Vocalion Orch. Accomp.....Giulio Crimi 10
- STANDARD SELECTIONS
- 30136 Will You Remember? (From "Maytime") (Young-Romberg)—Baritone, Vocalion Orch. Accomp.....John Charles Thomas 10
- 30138 Chanson Provencale (Parker-dell'Acqua)—Soprano, Vocalion Orch. Accomp.....Sara Kouns 10
- 48001 Mavis (Lefevre-Craxton)—Tenor, Vocalion Orch. Accomp..... 12
- Kashmiri Song (Hope-Woodforde-Finden)—Tenor, Vocalion Orch. Accomp.....Colin O'More 12
- 30139 Last Rose of Summer (Moore)—Soprano, Harp, Flute and Violin Accomp.....May Peterson 10
- CHRISTMAS SELECTIONS
- 52020 Silent Night, Holy Night (Gruber)—Contralto, Vocalion Orch. Accomp.....Marguerite D'Alvarez 12
- 24020 Adeste Fideles (Come, All Ye Faithful) (Portugal)—Tenor, Vocalion Orch. Accomp, Colin O'More and Shannon Four 10
- Christmas Carols (It Came Upon a Midnight Clear) (There Came Three Kings) (Arr. by R. H. Bowers)—Vocalion Orch. Accomp, The Cathedral Quartet 10
- 14244 The Children's Christmas, Part 1 (Christmas Eve) (A Dream of Santa Claus) (Arr. by R. H. Bowers).....The Aeolian Concert Band 10
- The Children's Christmas, Part 2 (Christmas Morning) (The Awakening) (Arr. by R. H. Bowers).....The Aeolian Concert Band 10
- INSTRUMENTAL SELECTIONS
- 30140 Hungarian Dance, No. 5 (Brahms)—Violin, Piano Accomp. by Emanuel Balaban.....Sasha Culbertson 10
- MONOLOGUE SELECTIONS
- 14245 Me and Grant.....Frank Bacon 10
- Lightnin' Bill Jones' Escape From the Indians, Frank Bacon 10
- POPULAR SELECTIONS
- 14246 My Galway Rose (From "Irish Eyes") (Kershaw-Scanlan)—Orch. Accomp.....Arthur Burns 10
- When the Honeymoon Was Over (Fred Fisher)—Orch. Accomp.....Sam Ash 10
- 14247 Dapper Dan (Brown-Von Tilzer)—Orch. accomp, Irving Kaufman 10
- Ten Little Fingers and Ten Little Toes (Pease-White-Shuster-Nelson)—Orch. Accomp, Ernest Hare-Billy Jones 10
- 14248 Mandy 'N' Me (Kalmar-Conrad-Motzan)—Orch. Accomp.....Charles Hart-Elliott Shaw 10
- Plantation Lullaby (Stevens-Gillette-Holmer)—Orch. Accomp.....Shannon Four 10
- DANCE SELECTIONS
- 14249 It's You (Davis-Conrad)—Fox-trot, Played by Newport Society Orchestra 10
- Hugs and Kisses (Freed-Meyer)—Fox-trot, Played by Newport Society Orchestra 10
- 14252 Old Time Waltzes—Part 1—On the Bowery, Annie Rooney, When You Were Sweet Sixteen, After the Ball Is Over (Arranged by Selvin).....Played by Selvin's Dance Orchestra 10
- Old Time Waltzes—Part 2—A Bicycle Built for Two, Sweet Rosie O'Grady, In the Good Old Summer Time, East Side—West Side (Arranged by Selvin).....Played by Selvin's Dance Orchestra 10
- 14253 Bimini Bay (Kahn-Egan-Whiting)—Fox-trot, Played by Bennie Krueger's Dance Orchestra 10
- I've Got the Joys (Akst)—Fox-trot, Played by Bennie Krueger's Dance Orchestra 10
- 14254 Mississippi Cradle (Yellen-Olman)—Waltz, Played by Selvin's Dance Orchestra 10
- Song of Love (Waltz From "Blossom Time") (Schubert-Berte-Romberg).....Played by Jocker's Dance Orchestra 10
- 14255 Everybody Step (Introducing "They Call It Dancing") (Irving Berlin)—Fox-trot from "The Music Box Revue.".....Played by Jocker's Dance Orchestra 10
- How Many Times (Robinson-Tark)—Fox-trot, Played by Jocker's Dance Orchestra 10
- 52021 Song of the Flea (Moussorgsky)—Tenor, in Russian, Piano Accomp.....M. Vladimir Rosing 12
- 52022 Prince Vladimir's Cavatina ("Prince Igor") (Borodine)—Tenor, Orch. Accomp., in Russian 12

- sian.....M. Vladimir Rosing 12
- 30141 Spring Waters (Rachmaninoff)—Tenor, Piano accomp., in Russian.....M. Vladimir Rosing 10
- 35008 Poet and Peasant Overture—Part 1 (Von Suppe).....Played by Band of H. M. Life Guards 12
- Poet and Peasant Overture—Part 2 (Von Suppe).....Played by Band of H. M. Life Guards 12

EDISON AMBEROL RECORDS

REGULAR LIST

- 4383 Rainbow Isle Medley (Introducing "Like No a Like").....Waikiki Hawaiian Orchestra 10
- 4384 Ain't You Coming Out, Malinda? (H. Von Tilzer)—Orch. accomp.....Al Bernard and Ernest Hare 10
- 4385 Canadian Capers (Chandler-White-Cohen)—Fox-trot, for Dancing.....Harry Raderman's Jazz Orch. 10
- 4386 Boll Weevil Blues (Hess)—Orch. accomp.....Al Bernard 10
- 4387 Held Fast in a Baby's Hands (Perkins)—Tenor, Orch. accomp.....George Wilton Ballard 10
- 4388 Persia (Wheeler-Walsh-Young)—Fox-trot, for Dancing.....Orlando's Orchestra 10
- 4389 Sweet and Low (Barnby) and Forsaken (Koschat) Saxophone, orch. accomp.....Chester Gaylord 10
- 4390 Portobello Lassie (H. Lauder)—Orch. accomp, Glen Ellison 10
- 4391 Down at the Old Swimming Hole (Wilson-Brennan)—Tenor and Baritone, Orch. accomp, Billy Jones and Ernest Hare 10
- 4392 I Wonder Where My Sweet, Sweet Daddy's Gone (Hammed-Stark)—Fox-trot, for Dancing, Earl Fuller's New York Orchestra 10
- 4393 Mavourneen—Irish Eyes (McDonough-Scanlan)—Tenor, orch. accomp.....Walter Scanlan 10
- 4394 My Sunny Tennessee (Kalmar-H. & H. Ruby)—Fox-trot.....Broadway Dance Orchestra 10
- 4395 Yield Not to Temptation (Palmer)—Mixed voices, Metropolitan Quartet 10
- 4396 If You Only Knew (A. Von Tilzer)—Tenor, orch. accomp.....Allan Rogers 10
- 4397 Gee Willikens (Wilson-Brennan-Henshaw)—Rube song, orch. accomp.....Byron G. Harlan 10
- 4398 Tenderly (Little-Stanley-Dellon)—Fox-trot, for dancing.....Club de Vingt Orchestra 10
- 4399 In My Tippy Canoe (Introducing "Hunika")—Medley, for Dancing.....Green Bros. Novelty Band 10
- 4400 My Little Sister Mary (Wendling)—Tenor, orch. accomp.....Lewis James 10
- 4401 Merry Widow Waltz (Lehar).....Peerless Orch. 10
- 4402 Christmas Carols—Chimes, Bells of Trinity, New York.....Played by William B. Murray 10
- OCTOBER HITS
- 4378 Mandy 'N' Me (Conrad-Motzan)—Fox-trot, for dancing.....Club de Vingt Orchestra 10
- 4379 In the Old Town Hall (Johnson-Pease-Nelson)—Tenor, orch. accomp, Billy Jones and Mixed Chorus 10
- 4380 Mal (Introducing "I'd Like to Know Why I Fell in Love With You") (Conrad-Timberg)—Fox-trot.....Harry Raderman's Jazz Orchestra 10
- 4381 I Wonder If You Still Care For Me (Snyder)—Tenor, orch. accomp.....Walter Scanlan 10
- 4382 Catalina (Gay)—Fox-trot.....Broadway Dance Orch.

EDISON RE-CREATIONS

- 50843 Christmas Carols—Chimes, Bells of Old Trinity, New York, Played by.....William Murray 10
- Old-Home Songs—Chimes, Bells of Old Trinity, New York, Played by.....William Murray 10
- 50844 Chautauqua at Pun'kin Center (Stewart)—Rural Story.....Cal Stewart 10
- Laughing Girl Has Her Picture Took—Norwegian-English Monolog.....Ethel C. Olson 10
- 50845 Rainbow Isle Medley (Intro.: "Like No a Like"), Waikiki Hawaiian Orchestra 10
- Dreamy Hawaii (Vandersloot)—Waltz, Waikiki Hawaiian Orchestra 10
- 50853 Invincible Eagle March (Souza), New York Military Band 10
- Here, There and Everywhere March (Bosc), New York Military Band 10
- 80638 Ride of the Valkyries (Wagner), American Symphony Orchestra 10
- Prelude to Faust (Gounod), American Symphony Orchestra 10
- 80643 Nazareth (Gounod)—Baritone, Thomas Chalmers and Chorus 10
- Silent Night (Gruber)—Soprano, Tenor and Baritone, Elizabeth Spencer, John Young, Vernon Archibald 10
- 80645 Some Day (Wellings)—Violin, Violoncello, Flute and Harp.....Venetian Instrumental Quartet 10
- Tango Triste (Vecsey), Armand Vecsey and his Hungarian Orchestra 10
- 82237 No Night There (Danks)—Soprano.....Anna Case 10
- Love Lifted Me (Smith)—Soprano, Anna Case and Lyric Male Quartet 10
- 82238 Scène du Miroir (Mirror Scene) (Thais) (Massenet)—Soprano (in French).....Alice Verlet 10
- Duo de L'Oasis—Thais (Massenet)—Soprano and Baritone (in French), Alice Verlet and Arthur Middleton 10
- 82239 Largo—Xerxes (Händel)—Violin.....Albert Spalding 10
- Indian Lament (Dvorak-Kreisler)—Violin, Albert Spalding 10
- 82240 Angel's Serenade (Braga)—Soprano, with Violin Obligato.....Frieda Hempel-Albert Spalding 10
- Merry Widow Waltz (Lehar-Eisler)—Soprano, Frieda Hempel 10
- 82241 Quartet—Bella figlia dell' amore—Rigoletto (Verdi)—Mixed Quartet, Odette Le Fontenay-Elizabeth Spencer-Max Bloch-Arthur Middleton 10
- Quand' ero paggio—Falstaff (Verdi), and Deh vieni alla finestra—Don Giovanni (Mozart)—Bass and Baritone (in Italian).....Arthur Middleton 10
- MANDY 'N' ME AND ELEVEN OTHERS
- 50825 My Daddy (Norworth-Swanstrom-Morgan)—Tenor.....Jim Doherty 10
- I'm Looking for a Bluebird (To Chase My Blues Away) (Rich).....Aileen Stanley 10
- 50846 Mal (Intro. "I'd Like to Know Why I Fell in Love With You") (Conrad-Timberg)—Medley Fox-trot, for Dancing, Harry Raderman's Jazz Orch. 10
- Apache Love (Kendis-Krueger-Weslyn-Dyson)—Fox-trot, for Dancing.....Harry Raderman's Jazz Orch. 10
- 50847 Mandy 'N' Me (Conrad-Motzan)—Fox-trot, for Dancing.....Club de Vingt Orch. 10
- Tenderly (Little-Stanley-Dellon)—Fox-trot, for Dancing.....Club de Vingt Orch. 10
- 50848 I Want My Mammy (Breau)—Tenor, Vernon Dalhart 10

ADVANCE RECORD BULLETINS FOR DECEMBER—(Continued from page 190)

- My Little Sister Mary (Wendling)—Tenor, Lewis James
50849 Mother, I Didn't Understand (Piantadosi)—Tenor, Walter Scanlan
Kentucky Home (Brashen-Weeks)—Male Voices, Crescent Trio
50850 Three o'Clock in the Morning (Intro. "Swanee River Moon") (Robledo-Clarke)—Medley
Waltz, for Dancing.....Club de Vingt Orch.
Rosy Cheeks (Squires)—Fox-trot, for Dancing, Club de Vingt Orch.
EDISON FLASHES FOR OCTOBER
50842 Merry Widow Waltz (Lehar).....Peerless Orch.
Maid of the Mountains (Fraser-Simson)—Selection.....Peerless Orch.
50851 Sweet Lady (Intro. "Listen to Me") ("Tangerine") (Crumit-Zooh-Carlo-Sanders)—Medley
Fox-trot.....Broadway Dance Orch.
By the Waters of Killarney (Sanders-Carlo)—Waltz.....Broadway Dance Orch.
50852 On a Little Side Street (Harris-Howard), Ada Jones-Billy Jones
When Francis Dances With Me (Violinsky), Ada Jones-Billy Jones
50854 Fancies (Spencer)—Fox-trot, for Dancing, Green Bros.' Novelty Band
Mississippi Cradle (Intro. "Always in My Dreams") (Olman-Cooke), Green Bros.' Novelty Band
50855 Plantation Lullaby (Stevens-Gillette-Holmer)—Male Voices.....Crescent Trio
Ten Little Fingers and Ten Little Toes (Down in Tennessee) (Pease-White)—Tenor and Baritone.....Billy Jones-Ernest Hare
50856 Somewhere in Naples (Zamecnik)—Fox-trot, for Dancing.....Lanin's Orch.
Yoo-Hoo (Jolson)—Fox-trot, for Dancing, Lanin's Orch.

BRUNSWICK RECORDS

- TWENTIETH RELEASE
30018 Carmen—Air de la fleur (Flower Song) (Act II) (Bizet)—Tenor, with orchestra, in French, Mario Chamlee
16044 Tosca—Vissi d'arte (Love and Music) (Act II) (Puccini)—Soprano, with orchestra, in Italian, Florence Easton
30020 Pagliacci—Prologo (Prologue) (Leoncavallo)—Baritone, with orchestra, in Italian, Giuseppe Danise
30019 Liebestraum (A Dream of Love) (Liszt)—Piano-forte solo.....Leopold Godowsky
30021 Meditation (From "Thais") (Massenet-Marsick)—Violin solo, with orchestra.....Max Rosen
13029 Bohemian Girl—Then You'll Remember Me (Act III) (Balfe)—Tenor, with orchestra, Theo Karle
Love's Garden of Roses (Rutherford-Wood)—Tenor, with orchestra.....Theo Karle
5047 Mighty Lak' a Rose (Stanton-Nevin)—Soprano, with orchestra.....Irene Williams
Lullaby (From "Erminie") (Jakobowski)—Soprano, with orchestra, Irene Williams and Brunswick Light Opera Co.
2145 On the Campus March (Sousa)—Concert Band, Walter B. Rogers and His Band
Legion of Honor March (Sousa)—Concert Band, Walter B. Rogers and His Band
2146 Herd Girl's Dream (Labitzsky)—Violin, flute, harp.....Gondolier Trio
Love's Dream After the Ball (Czibulka)—Violin, flute, harp.....Riviera Trio
2140 Ain't You Coming Out, Malinda? (Sterling-Moran-Von Tilzer)—Tenor and male trio with orchestra.....Billy Jones and Male Trio
Ten Little Fingers and Ten Little Toes (Pease-White-Schuster-Nelson)—Tenor and baritone, with orchestra.....Billy Jones and Ernest Hare
2147 Don't You Remember the Time? (Williams)—Soprano and tenor, with orchestra, Irene Audrey and Charles Hart
Love Sends a Little Gift of Roses (Cooke-Openshaw)—Baritone, with orchestra.....Ford Palmer
2141 Swanee River (Clarke)—Tenor and baritone, with orchestra.....Charles Hart and Elliott Shaw
Gone, But Not Forgotten (Grant)—Baritone, with orchestra.....Ernest Hare
5067 I Wonder If You Still Care for Me (Ted Snyder)—Fox-trot, for dancing.....Isham Jones Orchestra
June Moon (Magine-Straight-Lyons)—Fox-trot, for dancing.....Isham Jones Orchestra
2144 One Kiss (Burnett-Arnheim)—Fox-trot, for dancing.....Selvin's Orchestra
Love Will Find a Way (From "Shuffle Along") (Sissle-Blake)—Fox-trot for dancing, Selvin's Orchestra

PATHE FRERES PHONOGRAPH CO.

- CHRISTMAS RECORDS
A22433 Christians Awake, Salute the Happy Morn, Shannon Four
God Rest Ye Merrie Gentlemen.....Shannon Four
A22432 Excelsior.....Lewis James and Elliott Shaw
The Voice of the Chimes.....Acme Male Quartet
A20472 How Santa Claus Makes His Toys—Descriptive.....Gilbert Gerard and Russell Hunting
How Santa Distributes His Toys, Gilbert Gerard and Russell Hunting
A22191 Christmas Eve in the Toy Shop—Descriptive, Gilbert Gerard and Russell Hunting
'Twas the Night Before Christmas—Descriptive, Gilbert Gerard and Russell Hunting
A29219 Adeste Fideles (O Come, All Ye Faithful), Shannon Four
The Holy City.....Helen Clark
A40058 Hark! the Herald Angels Sing, Tempo Male Quartet
While Shepherds Watched Their Flocks By Night.....Tempo Male Quartet
A40186 Silent Night, Holy Night, Mendelssohn Mixed Quartet
It Came Upon the Midnight Clear.....Charles Hart
Noel (O Holy Night).....Percy Hemus
Star of Bethlehem.....Percy Hemus
62005 La Charité—In French.....Noté
Noel (Adam)—In French.....Noté
54058 Silent Night, Holy Night.....Margaret Matzenauer
40209 March of the Toys (From "Babes in Toyland") Waldorf-Astoria Concert Orchestra
Habanera.....Waldorf-Astoria Concert Orchestra
20452 O Come, All Ye Faithful and Christians Awake.....Pathé Military Band
Hark, the Herald Angels Sing and While Shepherds Watched.....Pathé Military Band
49204 Christmas Spirit.....Harmony Orch. 12
Christmas Chimes.....Harmony Orch. 12
1065 Oh, Tannenbaum.....Chor der Oper, Berlin 10
Stille Nacht, heilige Nacht, Chor der Oper, Berlin 10
1066 Zu Bethlehem geboren.....Chor der Oper, Berlin 10
Eine feste Burg.....Chor der Oper, Berlin 10

- STANDARD VOCAL
A20635 My Pretty Jane (The Bloom Is on the Rye), Charles Harrison
Sweet Genevieve.....Charles Harrison
A20636 Long Ago in Alcalá.....Wilfred Glenn
The Ringers.....Wilfred Glenn
A20607 Mah Lindy Lou.....Lora Hoffman
Mighty Lak' a Rose.....Lora Hoffman
INSTRUMENTAL
A20638 Three o'Clock in the Morning—Waltz, mandolin and guitar, DePace Brothers
Moon River—Waltz, mandolin and guitar, DePace Brothers
BAND AND ORCHESTRA
A20637 Anvil Chorus (From "Il Trovatore") (Verdi) Empire State Military Band
The Jolly Coppersmith (Peters)—March, Empire State Military Band
NEW DANCE RECORDS
A20630 Say It With Music (From Irving Berlin's "Music Box Revue")—Fox-trot, Casino Dance Orch. 10
Apache Love—Fox-trot, Joseph Samuels' Music Masters 10
A20628 Yoo-Hoo—Fox-trot, Ernest Hussar and His Hotel Claridge Orch. 10
When the Honeymoon Was Over—Fox-trot, Joseph Samuels' Music Masters 10
A20633 Sweet Lady (From "Tangerine")—Fox-trot, Markels' Society Orch. 10
Dream (From "Sonny")—Fox-trot, Markels' Society Orch. 10
A20632 Tenderly—Fox-trot.....Merry Melody Men 10
Bimini Bay—Fox-trot.....Merry Melody Men 10
A20629 Mississippi Cradle—Waltz, Green Brothers' Novelty Band 10
I Want My Mammy—Fox-trot, Green Brothers' Novelty Band 10
A20631 It Must Be Someone Like You—Fox-trot, Joseph Samuels' Music Masters 10
I Wonder if You Still Care for Me?—Fox-trot, Markels' Society Orch. 10
A20634 Wang Wang Blues—Fox-trot, The Seven Black Dots 10
Shake It and Break It—Fox-trot, Lanin's Southern Serenaders 10

- "POP SUPPLEMENT" FOR JANUARY, 1922.
POPULAR VOCAL
A20645 Baby Face.....Carlton Williams
Birds of a Feather.....Lewis James and Elliott Shaw
A20646 Ten Little Fingers and Ten Little Toes (Down in Tennessee).....Billy Jones and Ernest Hare
Dapper Dan.....Billy Jones and Ernest Hare
A20647 Brother Low Down.....Al Bernard
I've Got the Blues (But I'm Just Too Mean to Cry).....Al Bernard
A20648 Pretty Little Honey Lou.....Vernon Dalhart
On a Little Side Street.....Charles Hart-Elliott Shaw
A20625 Cry-baby Blues—Dance Rhythm.....Ernest Hare 10
I Ain't Nobody's Darling.....Byron G. Harlan 10
A20626 Plantation Lullaby.....Crescent Trio 10
Down in Happy Valley, Charles Hart-Elliott Shaw 10
A20639 When Francis Dances With Me.....Patricola 10
I Ain't Gonna Be Nobody's Fool.....Patricola 10
SPECIAL (NEGRO COMEDIENNE)
A20627 He Took It Away From Me—Dance Rhythm, Lavinia Turner and Jas P. Johnson's Harmony Seven 10
If I Were Your Daddy (And You Were a Mamma to Me)—Dance Rhythm, Lavinia Turner and Jas P. Johnson's Harmony Seven 10

- DANCE RECORDS
A20649 I've Got the Joys—Fox-trot, Lanin's Southern Serenaders
Mandy 'N' Me—Fox-trot, Lanin's Southern Serenaders
A20650 Tuck Me to Sleep in My Old 'Tucky Home—Fox-trot.....Merry Melody Men
Fancies—Fox-trot.....Merry Melody Men
A20652 Roses and You—Fox-trot, Vernon Country Club, Cafe de Paris, New York
Mister Minor—Fox-trot, Green Brothers Novelty Band
A20653 It's You—Fox-trot, Vernon Country Club, Cafe de Paris, New York
June Moon—Fox-trot.....Selvin's Novelty Orchestra
A20654 Song of Love (From "Blossom Time" Waltz)—Selvin's Novelty Orchestra
Good-bye, Pretty Butterflies—Fox-trot, Selvin's Novelty Orchestra
A20655 Love Will Find a Way (Introducing "In Honey-suckle Time")—Fox-trot.....The Seven Black Dots
Bandana Days (Introducing "Gypsy Blues")—Fox-trot.....The Seven Black Dots
A20651 Leave Me With a Smile—Fox-trot, Woodland Trio
Teach Me—Fox-trot.....Woodland Trio

- HAWAIIAN
A20643 Dream Kiss—With saxophone, Ferera and Franchini
In My Tippy Canoe—With saxophone, Ferera and Franchini
Records marked "A" may be obtained as Actuelle (steel-needle-played) records as well as Pathé Sapphire records.

- 6481 It's You (Davis-Conrad)—Fox-trot, Lanin's Famous Players
Bimini Bay (Whiting-Kahn-Egan)—Fox-trot, Lanin's Famous Players
4782 Little Orphan Annie (James Whitcomb Riley)—Recitation.....Harry Humphrey
Just 'Fore Christmas—Recitation.....Harry Humphrey
4783 The Forge in the Forest (Michaelis)—Knights of Columbus Band.....Paul Clifford, Conductor
Anvil Chorus (From "Il Trovatore") (Verdi)—Knights of Columbus Band.....Paul Clifford, Cond.
4784 Knights of Columbus March (Clifford)—Knights of Columbus Band.....Paul Clifford, Conductor
Sabre and Spurs (Sousa)—Knights of Columbus Band.....Paul Clifford, Conductor
10051 Alma Mater (University of Pitt) (Baird)—Band accomp.....Criterion Quartet
Hail to Pitt (University of Pitt) (Kirk-Taylor)—Band accomp.....Criterion Quartet
10052 Alma Mater (Carnegie Tech) (Taylor)—Band accomp.....Criterion Quartet
Dear Old Tech (Carnegie Tech) (Cameron-Cornwall)—Band accomp.....Criterion Quartet

CARDINAL PHONOGRAPH CO.

- THREE BIG SPECIALS
2061 Say It With Music (From Irving Berlin's "Music Box Revue")—Fox-trot, Cardinal Dance Orch.
Direction Maurice C. Rumsey
Tenderly—Fox-trot.....Cardinal Dance Orch.
Direction Maurice C. Rumsey
2064 Who'll Be the Next One to Cry Over You?—Fox-trot.....The Merry Melody Men
I Wonder if You Still Care?—Fox-trot, The Merry Melody Men
2066 When Francis Dances With Me—Orch. Accomp., Billy Jones
Figaro.....Arthur Fields
Accomp. by The Merry Melody Men

- CARDINAL VOCAL HITS
2067 Ten Little Fingers and Ten Little Toes—Duet, With Orch. Accomp.....Ernest Hare-Billy Jones
Weep No More, My Mammy—Orch. Accomp., Ernest Hare
2065 Mandy 'N' Me—Duet, With Orch. Accomp., Arthur Fields-Chas. Harrison
Bimini Bay.....Arthur Fields
Accomp. by The Merry Melody Men

- SACRED CHRISTMAS SELECTIONS
2068 Safe in the Arms of Jesus—Orch. Accomp., Reed Miller
The Ninety and Nine—Orch. Accomp.....Reed Miller

- CARDINAL DANCE HITS
2062 When the Sun Goes Down—Fox-trot, Cardinal Dance Orch.
Direction Maurice C. Rumsey
June Moon—Fox-trot.....Ben Selvin's Novelty Orch.
2063 My Sunny Tennessee—Fox-trot, Ben Selvin's Novelty Orch.
Figaro—Novelty One-step, Ben Selvin's Novelty Orch.

OKEH RECORDS

- OPERA—STANDARD—INSTRUMENTAL
50003 O Lovely Night (Landon Ronald)—Tenor with Orchestra.....John McCormack 12
52201 Martha—M'appari (Like a Dream) (Flotow)—Tenor (Italian) with Orchestra, Alessandro Bonci 12
52801 Otello—Morte d'Otello (Death of Othello) (Verdi)—Tenor (Italian) with Orchestra, Giovanni Zenatello 12
72102 Trovatore—Il balen del suo sorriso (The Tempest of the Heart) (Verdi)—Baritone (Italian) with Orchestra.....Riccardo Stracciari 10 1/2
72701 Tannhauser—Oh! tu, bell'astro (The Evening Star) (Wagner)—Baritone (Italian) with Orchestra.....Pasquale Amato 10 1/2
72303 Souvenir (Franz Drdla)—Violin Solo, Piano Accomp.....Jan Kubelik 10 1/2
(Above recordings were made in Europe)
4435 Minuet (Beethoven)—Violin Solo, Piano Accomp.....M. Michailow 10
Carnival of Venice—Violin Solo, Piano Accomp.....M. Michailow 10
4436 Am Meer (Schubert)—Piano Accomp., Cello Solo 10
Spring Awakening (Bach)—Piano Accomp., Cello Solo 10
4432 Comin' Thro' the Rye (Humoresque), Conway's Band 10
The Observing Visitor.....Conway's Band 10
4423 Wang Wang Blues—Octo Corda and Guitar Duet.....Sam Moore-Horace Davis 10
Tuck Me To Sleep in My Old Kentucky Home—Octo Corda and Guitar Duet, Sam Moore-Horace Davis 10

- VOCALS
4430 O Mary, Don't You Weep, Don't You Mourn—Spiritual Colored Quartet, Virginia Female Jubilee Singers 10
Lover of the Lord—Spiritual Colored Quartet, Virginia Female Jubilee Singers 10
4437 Go Down, Moses, Way Down in Egypt Land—Spiritual Colored Quartet, Virginia Female Jubilee Singers 10
When Jesus Christ Was Born—Spiritual Colored Quartet.....Virginia Female Jubilee Singers 10
4431 Saved By Grace—Sacred Baritone with Organ, Wilfred Glenn 10
Just As I Am—Sacred Baritone with Organ, Wilfred Glenn 10
4434 On the Road to Mandalay (From Kipling's "Barrack Room Ballads")—Baritone with Orchestra.....Bernard Ferguson 10
Armorer's Song (From Opera "Robin Hood")—Bass.....Charles E. Gallagher 10
4433 Macushla—Lyric Tenor with Orchestra, Gerald Griffin 10
Come Back to Erin—Lyric Tenor with Orch., Gerald Griffin 10
4176 Little Town in the Ould County Down—Tenor with Orchestra.....Henry Burr
Nora Acushla!—Tenor with Orchestra, Will Oakland 10
4439 On a Little Side Street—Contralto with Orchestra.....Ada Jones 10
Dozing—Contralto with Orchestra, Vaughn de Leath 10
4427 Mamma Wbip! Mamma Spank! (If Her Daddy Don't Come Home)—Popular Blues Vocal, Mamie Smith and Her Jazz Band 10
I'm Free, Single, Disengaged, Looking for Someone to Love—Popular Blues Vocal, Mamie Smith and Her Jazz Band 10
4422 My Sunny Tennessee—Baritone with Orchestra, Ernest Hare 10
Oh! Brother, What a Feelin'!—Baritone with Orchestra.....Ernest Hare 10

(Continued on page 192)

GENNETT LATERAL RECORDS

- 4778 Tuck Me to Sleep (Young-Lewis-Meyer)—Fox-trot.....Harry Raderman's Orchestra
Cho Cho San (Puccini)—Fox-trot, Falcone's Metronome Orchestra
10049 Hail, West Virginia (Miller-McWhorter-Deem)—Band accomp.....Criterion Quartet
Old Gold and Blue (Doxsee-Dexter)—Band accomp.....Criterion Quartet
4775 Peggy O'Neil (Pease-Nelson-Dodge)—Waltz, Joseph Knecht's Waldorf-Astoria Dance Orch.
That Haunting Waltz (Goldstein)—Waltz, Joseph Knecht's Waldorf-Astoria Dance Orch.
4746 Sweet Lady (From Musical Comedy "Tangerine") (Crumit)—Fox-trot, Lanin's Famous Players
Say It With Music (Berlin)—Fox-trot, Lanin's Famous Players
4774 Yoo Hoo (De Sylva-Jolson)—Tenor, with orch. accomp.....Arthur Fields
Wha Wha (That Imaginary Isle) (Furman-Stevens)—Tenor, with orch. accomp.....Arthur Fields
4776 Who'll Be the Next One to Cry Over You?—(Black)—Fox-trot.....Black Hawk Inn Orch.
I Wonder If You Still Care for Me (Snyder)—Fox-trot.....Black Hawk Inn Orch.
4779 O Sanctissima (Florida)—Chimes, Sterling Brass Quintet
Adeste Fideles (O Come All Ye Faithful) (Florida)—Chimes.....Sterling Brass Quintet
4780 Ten Little Fingers (and Ten Little Toes) (Pease-White-Schuster-Nelson)—Tenor, with orch. accomp.....Charles Harrison
When Francis Dances With Me (Ryan-Violinsky)—Tenor, with orch. accomp.....Arthur Fields

ADVANCE RECORD BULLETINS FOR DECEMBER—(Continued from page 191)

- 4429 I Ain't Nobody's Darling—Rube Song, Tenor with Orchestra.....Byron G. Harlan 10
- Down Where I Belong—Rube Song, Tenor with Orchestra.....Byron G. Harlan 10
- 4428 Darktown Court Room—Talking Record, Shelton Brooks & Co. 10
- You Can't Come In—Dialogue, Miller & Lyles 10
- DANCE SELECTIONS**
- 4444 Drowsy Head—Waltz....Okeh Marimba Band 10
- Sleepy Head—Waltz....Okeh Marimba Band 10
- 4440 Cho Cho San (On Melodies by Puccini, Arranged by Hugo Frey)—Fox-trot, Harry Raderman's Jazz Orchestra 10
- Glow, Little Lantern of Love—Fox-trot, Green Brothers' Novelty Band 10
- 4438 Yoo-Hoo—Fox-trot....Rega Dance Orchestra 10
- Say It With Music—Fox-trot, Rega Dance Orchestra 10
- 4442 Mississippi Cradle—Waltz, Green Brothers' Novelty Band 10
- Stand Up and Sing for Your Father (An Old-Time Tune)—Waltz, Green Brothers' Novelty Band 10
- 4443 Fancies—Fox-trot.....Damon's Orchestra 10
- Figaro—Italian Novelty One-step, Jos. Knecht's Waldorf Astoria Dance Orch. 10
- 4441 My Sunny Tennessee—Fox-trot, Harry Raderman's Jazz Orchestra 10
- I Wonder If You Still Care For Me—Fox-trot, Jos. Knecht's Waldorf-Astoria Dance Orch. 10
- 4424 Remember the Rose—Fox-trot....Ray Miller, Melody King, and His Black and White Melody Boys 10
- If You Want Me, Whistle—Fox-trot, Ray Miller, Melody King, and His Black and White Melody Boys 10
- 4425 Ma—Fox-trot.....Jos. Samuels' Jazz Band 10
- I've Got the Joys—Fox-trot, The Tampa Blue Jazz Band 10
- 4426 Just Like a Rainbow—Fox-trot, Damon's Orchestra 10
- Sunny Side Sal—Fox-trot...Damon's Orchestra 10
- 4420 Hello! Little Girl of My Dreams—Fox-trot, Damon's Orchestra 10
- Gruwald's Serenade (Intro.: "Mighty Lak" a Rose")—Medley Fox-trot, Damon's Orchestra 10
- 4421 Canadian Capers—Fox-trot, Damon's Orchestra 10
- Dixie—One-step.....Markel's Orchestra 10

EMERSON PHONOGRAPH CO., INC.

DANCES

- 10450 Ma (Con. Conrad)—Fox-trot, Piano Solo, Eubie Blake
- Sweet Lady (From Musical Production "Tangerine") (Johnson-Crumit-Zoob)—Medley Fox-trot, Piano Solo.....Eubie Blake
- 10452 Tuck Me to Sleep (In My Old Tucky Home) (George W. Meyer)—Fox-trot, Bennie Krueger's Orchestra
- Glow, Little Lantern of Love (Fred Fisher)—Fox-trot.....Bennie Krueger's Orchestra
- 10453 When the Honeymoon Was Over (Fred Fisher) Fox-trot.....Joseph Samuels' Music Masters
- Tenderly (Little-Stanley-Dellon)—Fox-trot, Joseph Samuels' Music Masters
- 10454 Baby Face (Benson-Howard)—Fox-trot, Van Eps Specialty Four
- How Many Times (Intro.: "Mamma Whip, Mamma Spank") (Robinson-Turk)—Fox-trot, Van Eps Specialty Four
- 10455 Rosy Cheeks (Young-Parish-Squires)—Fox-trot, Jos. Knecht's Waldorf-Astoria Dance Orchestra
- Love Me All of the Time (A. MacIntosh)—Fox-trot, Jos. Knecht's Waldorf-Astoria Dance Orchestra
- SONG HITS FOR DECEMBER**
- 10451 Bimini Bay (Whiting-Kahn-Egan)—Novelty Song, Orch. Accomp.....Arthur Fields
- Mandy 'N' Me (Kalmar-Conrad-Motzan)—Tenor Solo, Orch. Accomp.....Irving Kaufman
- 10456 Cry Baby Blues (Young-Lewis-Meyer)—Character Song, Orch. Accomp.....Eddie Nelson
- What I Want to Doodle Do For You (Von Tilzer-Brown)—Comedy Song, Orch. Accomp., Fred Hillebrand
- 10457 I Wonder If You Still Care For Me (Smith-Snyder)—Tenor Solo, Orch. Accomp....Sam Ash
- Ten Little Fingers and Ten Little Toes (Down in Tennessee) (Pease-White-Schuster-Nelson) Novelty Song, Orch. Accomp., Ernest Hare and Billy Jones
- 10458 Plantation Lullaby (Stevens-Gillette-Holmer)—Tenor Solo, Orch. Accomp.....Vernon Dalhart
- On a Little Side Street (Harris-Howard)—Tenor Solo, Orch. Accomp.....Charles Harrison

STANDARD AND HOLIDAY NUMBERS

- 10459 Kiddies' Patrol (Christmas Eve) (Walter Rogers)—Descriptive.....Emerson Concert Band
- Kiddies' Dance (Christmas Morning) (Walter Rogers)—Descriptive.....Emerson Concert Band
- 10460 Lead, Kindly Light (Newman-Dykes)—Male Quartet.....Trinity Quartet
- Almost Persuaded (P. P. Bliss)—Male Quartet, Trinity Quartet
- 10461 My Faith Looks Up to Thee (Palmer-Mason)—Tenor and Contralto Duet, Orch. Accomp., Reed Miller-Nevada Van der Veer
- The Lord Is My Shepherd (Smart-Passmore)—Tenor and Contralto Duet, Orch. Accomp., Reed Miller-Nevada Van der Veer
- 10462 Rustle of Spring (Sinding)—Piano Solo, Mana Zucca
- Valse Brillante (Mana Zucca)—Piano Solo, Mana Zucca
- 10463 Barcarolle (From "Tales of Hoffmann") (Offenbach)—Instrumental Trio.....Longo Trio
- Were My Song With Wings Provided (Reynaldo Hahn)—Instrumental Trio.....Longo Trio
- 10464 The Last Rose of Summer (Moore)—Soprano Solo, Orch. Accomp.....Vivian Holt
- Just A-Wearyin' For You (Stanton-Jacobs-Bond)—Contralto Solo, Accomp. by Piano, Violin and Cello.....Corinne Morgan Welsh
- 1087 Holy Night, Peaceful Night (Mohr-Gruber)—Male Quartet.....Shannon Four
- Adeste Fideles (Come, All Ye Faithful) (J. Reading)—Male Quartet.....Shannon Four
- 10270 Hark! The Herald Angels Sing (Mendelssohn)—Male Quartet.....Stellar Quartet
- Joy to the World (Handel)—Male Quartet, Stellar Quartet

CONNORIZED MUSIC CO.

- 3019 Bimini Bay—Orch. accomp...Sung by Irving Kaufman
- Wha Wha—Orch. accomp....Sung by Arthur Fields
- 3020 Yoo-Hoo—Orch. accomp....Sung by Arthur Fields
- When the Honeymoon Was Over—Orch. accomp., Sung by Sam Ash

- 3021 Sweet Lady (From "Tangerine")—Fox-trot, Lanin's Famous Players
- Say It With Music—Fox-trot...Lanin's Famous Players
- 3022 When Francis Dances With Me—Orch. accomp., Sung by Arthur Fields
- Ten Little Fingers and Ten Little Toes (Pease-White-Schuster-Nelson)—Orch. accomp., Sung by Charles Harrison
- 3023 Peggy O'Neil—Waltz....Waldorf-Astoria Dance Orch.
- Why, Dear?—Fox-trot.....Merry Melody Men
- 3024 Tuck Me to Sleep (Lewis-Young-Meyer)—Fox-trot.....Harry Raderman's Orchestra
- My Sunny Tennessee (Kalmar-Ruby)—Fox-trot, Benny Krueger's Orchestra
- NUOVI DISCHI ITALIANI**
- 121 Mistere 'E Marechiaro (Raffaello M. Grimaldi, L. Donadio)—Accomp. Dell' Orchestra Napoletana, M. Scialpi, Tenore 10
- Tradimento E' Ammore (Raffaello M. Grimaldi, L. Donadio)—Accomp. Dell' Orchestra Napoletana, M. Scialpi, Tenore 10
- 122 Sorrisi Di Culla—Mazurka, Orchestra Degli Arditi, J. Cassara 10
- Stella Lucente—Mazurka, Orchestra Degli Arditi, D. Jetti 10
- 123 Diamond Walzer (J. Tripepi), Orchestra Degli Arditi 10
- Tea Party Walzer (L. Vitak), Orchestra Degli Arditi 10
- 124 Cara Piccina (Bovio, Lama)—Accomp. Dell' Orchestra Napoletana, Frances De Palma, Soprano
- Come Le Rose (A. Cenise, G. Lama)—Accomp. Dell' Orchestra Napoletana, Frances De Palma, Soprano 10
- 125 E Caruso' O Rre D' 'O Canto (L. Cica, L. Canora)—Accomp. Dell' Orchestra Napoletana, M. Scialpi, Tenore 10
- Cavalleria Rusticana (Mascagni)—Intermezzo, Symphony Orchestra (P. Florida, Director) 10

OLYMPIC DISC RECORD CORP.

DANCE RECORDS

- 15130 Everybody Step (From "Music Box Revue" (Irving Berlin)—Fox-trot....Club Maurice Orch.
- Stars (Gillespie-Alden)—Fox-trot, Club Maurice Orch.
- 15131 It's You (Davis-Conrad)—Fox-trot, Yerkes' Jazzrimba Orch.
- Leave Me With a Smile (Koehler-Burnett)—Fox-trot.....Yerkes' Jazzrimba Orch.
- 15132 How Many Times (Turk-Robinson)—Fox-trot, Yerkes' S. S. Flotilla Orch.
- Have You Forgotten (Burtlett-Cooper-Stevenson)—Fox-trot.....Yerkes' S. S. Flotilla Orch.
- 15133 Wabash Blues (Ringle-Meiken)—Fox-trot, Club Maurice Dance Orch.
- When Francis Dances With Me (Ryan-Violinsky)—Waltz.....Palm Beach Dance Orch.
- 15134 Sal-O-May (Costello-Stolz)—Fox-trot, Club Maurice Dance Orch.
- Stop! Rest a While (Gilbert-Brymn)—Fox-trot, Palm Beach Dance Orch.

POPULAR SONGS

- 14116 Birds of a Feather (MacGowan & Moran)—Tenor with orch.....Vernon Dalhart
- Weep No More (My Mammy) (Mitchell-Clare-Pollock)—Tenor with orch.....Vernon Dalhart
- STANDARD VOCALS**
- 17114 A Song of India (From "Sadko") (Rimsky-Korsakow)—Contralto with orch. accomp., Enid Johnson
- Oh, Dry Those Tears (Del Riego)—Contralto with orch. accomp.....Enid Johnson

INSTRUMENTALS

- 18115 Dream of Love (Liebestraum) (Franz Liszt)—Piano solo.....Joseph Kardos
- Waltz (No. 14) (Chopin)—Piano solo...Joseph Kardos
- 18116 Serenade (Drigo)—Violin, cello and piano, Philharmonic Trio
- Silent Night, Holy Night (Franz Gruber)—Violin, cello and piano.....Philharmonic Trio
- OPERATIC**
- 19109 Toreador Song (From "Carmen") (Bizet)—Baritone with orch.....Greek Evans
- 19110 The Tempest of the Heart (Il balen del suo sorriso) (From "Il Trovatore") (Verdi)—Baritone with orch.....Greek Evans

ARTO RECORDS

DANCE RECORDS

- 9106 Weep No More, My Mammy (L. Pollock)—Fox-trot.....Louis Cohen and His Orchestra
- Crooning (Intro.: "Love Me All of the Time") (W. F. Caesar-R. Perkins)—Medley fox-trot, Merry Melody Men
- 9107 Birds of a Feather (J. McGowan-E. Moran)—Fox-trot.....Louis Cohen and His Orchestra
- Glow, Little Lantern of Love (F. Fisher)—Fox-trot.....Louis Cohen and His Orchestra
- 9108 Everybody Step (From "Music Box Revue") (I. Berlin)—Fox-trot.....ARTO Dance Orchestra
- Song of Love (From "Blossom Time") (S. Romberg)—Waltz.....ARTO Dance Orchestra
- POPULAR VOCAL RECORDS**
- 9104 When Francis Dances With Me (B. Ryan-Violinsky)—Baritone solo, orch. accomp....Arthur Fields
- Ten Little Fingers and Ten Little Toes Down in Tennessee (Pease-Schuster-Nelson)—Tenor solo, orch. accomp.....Arthur Hall
- 9109 That's How I Believe in You (Dubin-Cunningham-Rule)—Duet, tenors, Charles Harrison and Everett Clark
- Feather-Bed Lane (Bryan-Paley-Gumble)—Tenor solo, orch. accomp.....Sam Ash
- 9110 I Ain't Gonna Be Nobody's Fool (F. Davis-G. Bennett)—Vocal blues, contralto solo, orch. accomp.....Dorothy Dodd
- I've Got the Blues, but I'm Just Too Mean to Cry (Parish-Young-Squires)—Vocal blues, contralto solo, orch. accomp.....Dorothy Dodd
- COLORED VOCAL "BLUES" RECORD**
- 9105 Mississippi Blues (Spencer Williams)—Vocal blues, contralto solo, orch. accomp., Alice Leslie Carter, accomp. by Jimmie Johnson's Jazz Boys
- Decatur Street Blues (Clarence Williams)—Vocal blues contralto solo, orch. accomp., Alice Leslie Carter, accomp. by Jimmie Johnson's Jazz Boys
- HAWAIIAN RECORD**
- 9111 Susquehanna Shore (H. D. Squires)—Waltz, duet, Hawaiian guitars.....Ferera and Franchini
- When Sweethearts Waltz (C. De Voll-L. Breau) Waltz, duet, Hawaiian guitars, Ferera and Franchini
- CHRISTMAS NOVELTY RECORD**
- 3089 Santa Claus Arrives (G. Gerard)—Descriptive specialty.....Gilbert Gerard
- Santa Claus Builds His Toys (G. Gerard)—Descriptive specialty.....Gilbert Gerard
- STANDARD VOCAL RECORD**
- 3084 Silent Night, Holy Night (F. Gruber)—Contralto solo, orch. accomp.....Nevada Vanderveer

- O Holy Night (A. Adam)—Contralto solo, orch. accomp.....Nevada Vanderveer
- OPERATIC ARIAS**
(Sung in Italian)
- 3085 Rigoletto ("La Donna Mobile") (G. Verdi)—Tenor solo, orch. accomp.....Antonio Rocca
- Rigoletto ("Cortigiani Vil Razza Dannata") (G. Verdi)—Baritone solo, orch. accomp....Carlo Ferretti
- 3086 Cavalleria Rusticana ("Brindisi") (P. Mascagni)—Tenor solo, orch. accomp.....Antonio Rocca
- Il Flauto Magico ("Aria Della Regina") (W. A. Mozart)—Soprano solo, orch. accomp....Eva Leoni
- 3087 Zaza ("Piccola Zingara") (R. Leoncavallo)—Baritone solo, orch. accomp.....Carlo Ferretti
- Cavalleria Rusticana ("Voi Lo Sapate") (P. Mascagni)—Soprano solo, orch. accomp., Mme. Genie Fonariova
- 3088 Faust ("Dio Possente") (C. Gounod)—Baritone solo, orch. accomp.....Milo Picco
- La Tosca ("Vissi d'Arte e d'Amor") (G. Puccini)—Soprano solo, orch. accomp., Mme. Genie Fonariova

WHY THE HAPPY MEDIUM IS BEST

There are some merchants who are optimistic no matter how bad conditions may be and there are others who are pessimistic all the time. Comparatively few dealers, however, adopt the happy medium. It is all very well to be optimistic, but there must be a clear understanding of the seriousness of the problems which the merchant must face if he would place his business on a profitable basis. The business man endowed with a superabundance of optimism, who sits back and takes life easy, sure that things will right themselves without his co-operation and help, is due for an unpleasant awakening when it is too late. Optimism is a good thing for a merchant to have and a very necessary quality, but it must be mixed with sound common sense and energy to overcome unfavorable conditions.

On the other hand, pessimism is just as bad, if not worse. When a man is pessimistic he naturally becomes discouraged and he soon adopts the "what-is-the-use" attitude. He does not go after business because he is sure in his own mind that there is no business to be had, and if he does not change his attitude and methods he will soon be classed among the failures.

The happy medium consists of facing the difficulties squarely and being actively on the job every minute. In short, it means a sane degree of optimism and confidence that business can be had if the proper steps are taken to secure it.

Advertising, properly conceived and placed, is the thing that builds reputation. Reputation is the force that influences a banker when it comes to extending credit.

Why Break Records? Just File Them!

That is if you have the wonderful Record filing system which is a feature of

The Marvelous MAGNOLA



Watching the Music Come Out

This is only one feature of many that will command your interest and attention. Let us send you handsome illustrated catalog and information as to our plans for helping you to make money with MAGNOLA.

MAGNOLA TALKING MACHINE COMPANY

OTTO SCHULZ, President
General Offices Southern Wholesale Branch
711 MILWAUKEE AVENUE 1530 CANDLER BLDG.
CHICAGO ATLANTA, GA.

Some Leading Jobbers of Talking Machines in America

TEST IT. OUR VICTOR Record Service

has a reputation for efficiency.
Suppose you try it.
E. F. DROOP & SONS CO.
1300 G. STREET, WASHINGTON, D. C.
231 N. HOWARD STREET, BALTIMORE, MD

Sherman, Clay & Co.
San Francisco, Los Angeles, Portland, Seattle, Spokane
PACIFIC COAST DISTRIBUTORS OF
VICTOR PRODUCTS

The PERRY B. WHITSIT CO.
Distributors of
Victrolas and Victor Records
COLUMBUS, OHIO

W. J. DYER & BRO.
DYER B'LD'G, ST. PAUL, MINN.
NORTHWESTERN DISTRIBUTORS
OF THE
VICTOR
Machines, Records and Supplies

Shipped Promptly to all
Points in the Northwest

Mickel Bros. Co.

Omaha, Nebraska
Des Moines, Iowa

Victor Distributors



Where Dealers May Secure **COLUMBIA** Product

Ready, Full Stocks, and Prompt Deliveries
from Convenient Shipping Centers
all over the United States.

Distributors

- Atlanta, Ga., Columbia Graphophone Co., 561-563 Whitehall St.
- Baltimore, Md., Columbia Graphophone Co., 16 South Howard St.
- Boston, Columbia Graphophone Co., 1000 Washington St.
- Buffalo, N. Y., Columbia Graphophone Co., 787 Main St.
- Chicago, Ill., Columbia Graphophone Co., 325 W. Jackson Blvd.
- Cincinnati, O., Columbia Graphophone Co., 317-321 East 8th Street.
- Cleveland, O., Columbia Graphophone Co., 1812 East 30th St.
- Dallas, Tex., Columbia Graphophone Co., 316 North Preston St.
- Denver, Colo., Columbia Stores Co., 1608 Glenarm Ave.
- Detroit, Mich., Columbia Graphophone Co., 115 State St.
- Kansas City, Mo., Columbia Graphophone Co., 2006 Wyandotte St.
- Los Angeles, Cal., Columbia Graphophone Co., 809 S. Los Angeles St.
- Minneapolis, Minn., Columbia Graphophone Co., 18 N. 3rd St.
- New Orleans, La., Columbia Graphophone Co., 517-525 Canal St.
- New York City, Columbia Graphophone Co., 121 West 20th St.
- Omaha, Neb., Columbia Graphophone Co., Eighth and Jackson Sts.
- Philadelphia, Pa., Columbia Graphophone Co., 40 N. 6th St.
- Pittsburgh, Columbia Graphophone Co., 632-640 Duquesne Way.
- Salt Lake City, Utah, Columbia Stores Co., 221 South West Temple.
- San Francisco, Cal., Columbia Graphophone Co., 345 Bryant St.
- Seattle, Wash., Columbia Graphophone Co., 911 Western Ave.
- Spokane, Wash., Columbia Stores Co., 161 South Post St.
- St. Louis, Mo., Columbia Graphophone Co., 1127 Pine St.
- Tampa, Fla., Tampa Hardware Co.

Headquarters for Canada:
Columbia Graphophone Co., 347 West Adelaide St., Toronto, Ont.

Executive Office
COLUMBIA GRAPHOPHONE CO.
Gotham National Bank Building New York

Wholesale Exclusively
EASTERN TALKING MACHINE CO.
85 Essex Street, Boston
VICTOR DISTRIBUTORS

Every talking machine jobber in this country should be represented in this department, no matter what kind he handles or where he is located. The cost is slight and the advantage is great.

CONSTRUCTIVE ARTICLES IN THIS ISSUE OF THE WORLD

Ready Reference for Salesmen, Dealers and Department Heads

Where the Talking Machine Does the Lecturing	3	Convention of Nebraska Victor Dealers	59-60-61
What Are You Doing to Make the Holidays One of Your Greatest Selling Periods?	4	Some Worth-while Sales Ideas.....	69
Music as an Aid to Workers.....	4	The Advertising Man Analyzed.....	76
The Importance of Knowing Human Nature in the Selling of Talking Machines	6	How Records Aided Young Tenor...	77
Business Developments and Prospects	8	Why the Talking Machine Business Should Be Clean.....	80
How the Wholesaler Helps the Dealer	8	Getting in Touch with Prospective Buyers	81
Why the Musical Season Should Interest the Dealer.....	8	Interesting Trade News from New England	83
Maintenance of Sound Credit Policies	9	A Sales Boosting Idea.....	89
Concentrating on the Holiday Business	9	Preventing Frosted Windows.....	92
The Value of the Really Personal Letter in Meeting Selling Problems	11	The Selections of Business Locations Important	96
Fundamentals of Salesmanship.....	14	Robert Gordon's Page of Merchandising Suggestions	109
An Idea for a Window Display.....	14	Photophone Combines Records of Sound and Action.....	110
Reaching the Slow Customer.....	15	Senate Votes to Free all Musical Instruments from Excise Taxation.....	111
How a New Talking Machine Store Was Successfully Put Over in a Novel Way	17	The Mid-West Point of View.....	114
Musical Interest Intensified by the Talking Machine	23	Distributors Service for Talking Machine Dealers	135
Planning an Especial Appeal for Juvenile Record Trade During the Holidays	25	News from the Dominion of Canada..	146
How to Transform the Thanksgiving Spirit Into Talking Machine Sales..	29	Featuring the Musical Possibilities of the Talking Machine.....	154-155
Financing Plan for Dealers.....	46	Record Music Spans Continent.....	159
Importance of Credits and Terms in Making a Talking Machine Store Pay	49	The Talking Machine Situation in Europe	184-185-186-187
		Late Patents of Interest to the Trade.	188
		Advance List of December Bulletins of Talking Machine Records.	190-191-192



15125
SOUTH SEA ISLES
My Sunny Tennessee
(Dance Record)

What Record Company Issues the
New Hits First?

OLYMPIC

What Record Is the Best Quality?

OLYMPIC

What Record Gives Best Results?

OLYMPIC



15126
MA!
Who'll Be the Next One
to Cry Over You
(Dance Record)

What Is the Fastest Selling Line of Records, Considering
the Time They Have Been on the Market?

WHY! **OLYMPIC** Of Course!

OLYMPIC produced the best Wang-Wang Blues, Peggy O'Neil,
When You and I Were Young, Maggie, Prelude in C-Sharp, Minor,
and many other well known compositions

Have You Compared Them?

(Dance Record)
SAY IT WITH MUSIC
Who Believed in You
15127



Write for Full Particulars

**OLYMPIC DISC RECORD
CORPORATION**

1666 Broadway
New York

We Have A Jobber In Your Section

The Capital Stock of the Olympic Disc Record
Corporation Is Controlled by Remington
Phonograph Corporation.

(Dance Record)
Song of Love
BIMINI BAY
15128





Remember this—

When people buy phonographs they want music exactly as the artists, themselves, render it.

The New Edison, before more than 5 million people, over 5 thousand times, and in comparison with over 75 prominent artists, has proved that there is no difference between the artist's actual singing or playing and the Edison RE-CREATION of that performance. It is the only phonograph which dares this test of direct comparison.

THOMAS A. EDISON, Inc.

ORANGE, NEW JERSEY

JOBBER OF THE NEW EDISON, EDISON RE-CREATIONS, THE NEW EDISON DIAMOND AMBEROLA AND BLUE AMBEROL RECORDS

CALIFORNIA
Los Angeles—Edison Phonographs, Ltd.
San Francisco—Edison Phonographs, Ltd.

COLORADO
Denver—Denver Dry Goods Co.

CONNECTICUT
New Haven—Pardee-Ellenberger Co., Inc.

GEORGIA
Atlanta—Phonographs, Inc.

ILLINOIS
Chicago—The Phonograph Co. Wm. H. Lyons (Amberola only).

INDIANA
Indianapolis—Kipp Phonograph Co.

IOWA
Des Moines—Harger & Blish.
Sioux City—Harger & Blish.

LOUISIANA
New Orleans—Diamond Music Co., Inc.

MASSACHUSETTS
Boston—Pardee-Ellenberger Co.
Iver Johnson Sporting Goods Co. (Amberola only).

MICHIGAN
Detroit—Phonograph Co. of Detroit

MINNESOTA
Minneapolis—Laurence H. Lucker

MISSOURI
Kansas City—The Phonograph Co. of Kansas City.
St. Louis—Silverstone Music Co.

MONTANA
Helena—Montana Phonograph Co.

NEBRASKA
Omaha—Shultz Bros.

NEW YORK
Albany—American Phonograph Co.
New York—The Phonograph Corp. of Manhattan.
Syracuse—Frank E. Bolway & Son, Inc. W. D. Andrews Co. (Amberola only).

OHIO
Cincinnati—The Phonograph Co.
Cleveland—The Phonograph Co.

OREGON
Portland—Edison Phonographs, Ltd.

PENNSYLVANIA
Philadelphia—Girard Phonograph Co.
Pittsburgh—Buehn Phonograph Co.
Williamsport—W. A. Myers.

RHODE ISLAND
Providence—J. A. Foster Co. (Amberola only).

TEXAS
Dallas—Texas-Oklahoma Phonograph Co.

UTAH
Ogden—Proudfit Sporting Goods Co.

VIRGINIA
Richmond—The C. B. Haynes Co., Inc.

WISCONSIN
Milwaukee—The Phonograph Co. of Milwaukee.

CANADA
Montreal—R. S. Williams & Sons Co., Ltd.
St. John—W. H. Thorne & Co., Ltd.
Toronto—R. S. Williams & Sons Co., Ltd.
Vancouver—Kent Piano Co., Ltd.
Winnipeg—R. S. Williams & Sons Co., Ltd.
Babson Bros. (Amberola only).