

# The TALKING MACHINE WORLD

For the makers & sellers of talking machines

Published Each Month by Edward Lyman Bill, Inc., at 373 Fourth Ave., New York, April 15, 1920



The best-known trade-mark in the world designating the products of the Victor Talking Machine Co.



THE INSTRUMENT OF QUALITY  
**Sonora**  
 CLEAR AS A BELL



**P**ERIOD Sonoras continue to increase in popularity. If you haven't already stocked them it is only a question of time—and a short time at that—until you do.

Sonora period styles are of superb elegance to the eye, they are wonderfully beautiful to the ear, and are designed for people whose requirements, in the selection of musical instruments, are far above the average.

No attempt has been made to reduce quality to fit a low price on these models. They are marked at fair figures, they are splendid values, they sell without difficulty and *completely satisfy* the most exacting purchasers in every respect.

The following period styles are available:

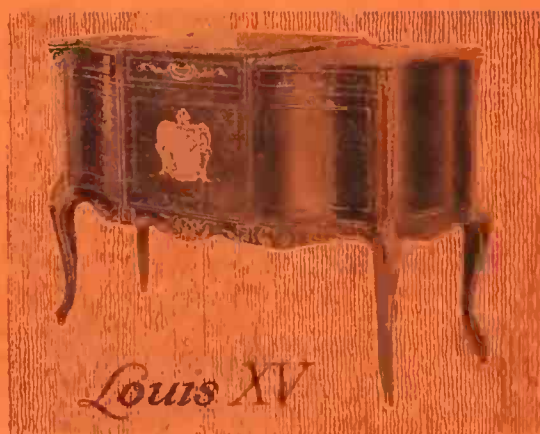

*Louis XV*



*Chippendale*



*Gothic*

- |                    |                            |
|--------------------|----------------------------|
| <i>Gothic</i>      | <i>William &amp; Mary</i>  |
| <i>Louis XV</i>    | <i>Italian Renaissance</i> |
| <i>Louis XVI</i>   | <i>Adam</i>                |
| <i>Jacobean</i>    | <i>Sheraton</i>            |
| <i>Queen Anne</i>  | <i>Colonial</i>            |
| <i>Chippendale</i> | <i>Duncan Phyfe</i>        |

Sonora is licensed and operates under BASIC PATENTS of the phonograph industry

Matchless upright and period designs \$60 to \$2,500

Special designs will be made to order. We are also prepared to place Sonora equipments in treasured cabinets which your customers now own.

**Sonora Phonograph Co., Inc.**

GEORGE E. BRIGHTSON, President

New York: 279 Broadway Fifth Avenue at 53rd St.

Canadian Distributors  
 I. MONTAGNES & CO.  
 Toronto

DEALERS EVERYWHERE

*The Highest Class Talking Machine in the World*



# The Talking Machine World

Vol. 16. No. 4

New York, April 15, 1920

Price Twenty-five Cents

## TALKING MACHINE EXPORTS GROW

Exports, Including Records, for Seven Months Ended January 31, 1920, Total \$4,260,671

WASHINGTON, D. C., April 6.—In the summary of exports and imports of the United States for the month of January, 1920 (the latest period for which it has been compiled), which has just been issued, the following figures on talking machines and records are presented:

The dutiable imports of talking machines and parts during January, 1920, amounted in value to \$102,657, as compared with \$26,299 worth which were imported during the same month of 1919. The total for seven months ended January, 1920, showed importations valued at \$459,684, as compared with \$143,312 worth of talking machines and parts imported during the same period of 1919.

Talking machines to the number of 5,980, valued at \$371,202, were exported in January, 1920, as compared with 3,904 talking machines, valued at \$114,311, sent abroad in the same period of 1919. The seven months' total showed that we exported 44,907 talking machines, valued at \$1,982,326, as against 26,391 talking machines, valued at \$779,605, in 1919, and 54,976 talking machines, valued at \$1,520,738, in 1918.

The total exports of records and supplies for January, 1920, were valued at \$364,181, as compared with \$330,829 in January, 1919. For the seven months ended January, 1920, records and accessories were exported valued at \$2,278,345; in 1919, \$1,540,787, and in 1918, \$1,171,138. This shows a steady gain.

## MAKE TALKING MOTION PICTURES

New Company With Capital of \$1,000,000 Just Incorporated in New York City

A new firm known as Kinephotolog has been incorporated in New York to make talking motion pictures; capital, \$1,000,000. The incorporators are B. L. Bloch, J. G. Saltzman and A. E. Epstein, 132<sup>1</sup> South Ninth street, Brooklyn.

## HOW WRITERS IN "SYSTEM" WOULD HELP THE INDUSTRY

R. Cantwell Tells What He Would Do if He Made Records, and Walter Engard Discourses on the Selling of Talking Machines—Some Editorial Criticisms and Commendations

In the interesting department conducted by System, "What I Would Do," Mr. R. Cantwell thus tells what he would do if he made records for talking machines:

"I would furnish with each record the words of that particular song. Sheets could be run off at small cost with my name upon them in large type. These copies would be very popular with customers. Dance records and many others give the tune but not the words, and those who buy them—to hear them again and again—usually want to know the words. Even with vocal records the words are often not clear enough to be fully understood, and owners of such records would be glad to have a copy of the words. Some very good records may be played any number of times without the listeners knowing just what the words are in certain parts of the song.

"I would emphasize this point of service to dealers, since sales would, I feel, increase in the stores where my records were sold. I would not only gain a lot of valuable publicity at small cost by this unusual service, but I would also feel reasonably sure that my sales would increase appreciably over those of competitors who did not provide the words with records."

The only trouble with this suggestion of Mr. Cantwell's is that the words of all the popular songs of the day are copyrighted and cannot be reprinted, even in part, without the consent of the publisher; otherwise the user is liable to a

## STRAWN-TUCKER CO. ADDS VOCALION

Little Rock Furniture House Becomes First Aeolian-Vocalion Representative in That City—Service Department Will Be Maintained

LITTLE ROCK, ARK., April 3.—The formal opening of the handsomely arranged new Aeolian-Vocalion department of the Strawn-Tucker Furniture Co., of this city, was held the middle of last month at 609 Main street. Although there are many Vocalions in the homes of music lovers here, there has never been an agency devoted to the retail sale of the instruments. The opening of the Vocalion department of the Strawn-Tucker Co. adds to the list of talking machine and phonograph stores, bringing to this community an instrument which has earned a reputation for musical excellence. A pleasing musical program was a feature of the opening event at which several prominent artists were present.

Miss Bertie Ivey, who has been with the Guy Blass Co. and the O. K. Houck Music Co., is in charge of the Vocalion department. In connection with the service department Miss Ivey has offered to assist on musical programs by presenting studies of the well-known operas, together with records by the great artists, or a study of one particular artist. She will also assist in arranging programs for clubs or other organizations looking toward the advancement of music generally.

## ORGANIZE WITH \$100,000 CAPITAL

The First National Piano Phonograph Music Co. has been incorporated to do business in Wilmington, Del., with a capital of \$100,000. The incorporators of the new company are Ferris Giles, M. Butler and L. S. Dorsey.

Siegel Bros., Livingston Manor, N. Y., have taken over the Victor and Columbia stock of the Lathrop Pharmacy, including all records and accessories, and will conduct a music business in the store on Main street.

fine of one dollar for every printed copy of the words. With this exception the idea is a good one.

In the same department of System for April, Walter Engard tells what he would do "If I Sold Talking Machines." He says:

"In a small city or town or in some outlying district of a larger city, I would offer to furnish the music for the local moving picture theatre. In exchange for this I would ask only that two or three different advertisements which I would have made would be thrown on the screen each evening.

"I would have an electric bulletin board upon which I would announce the name and price of each piece that was being played. I would select a large assortment of records, and give the audience a variety of good music. Too much repetition, no matter how popular the piece, would hurt the sale of the record; while only a very few repetitions would give the hearer just enough of a taste so that he would like it. He would then have to buy the record if he wanted to hear it any more."

Mr. Engard's suggestion is well worthy of consideration, and there is no question but that the dealer could in co-operation with the local moving picture theatre do much to advertise his store and the line of machines and records handled. Mostly every theatre boasts of either an orchestra or an organ these days, but in such cases talking machine music could be satisfactorily placed in the lobby of a theatre.

## TRY A RECORD CURE THIS SUMMER

Value of the Talking Machine as a Therapeutic—Dealers Should Point Out How the Public Can Be Saved From the Sanitarium

If you insist upon having or taking some kind of a cure this Summer, believing that unless you spend a lot of money and get the doctor to prescribe a lot of medicine which you promptly store away on the pantry shelf, you will be in your grave in a fortnight—if you still insist upon a cure, why not take a record cure and do the job right? And think of all the advantages this record cure has to recommend it! In the first place, you don't have to go away to a sanitarium, you can take it in your own home. You can send your wife to the country, thereby giving her a new idea of your generosity, and then go out and buy all the latest music and attachments for your talking machine and go home again. If you are restless, irritable, discontented, music will make a new man of you.

Those who have made a study of music and its workings prescribe it for these modern human ills. Music works benefit for real bodily ills, they point out, and call attention to the wonderful results that have been achieved. Then why shouldn't those ills which are more or less of the mind respond to the same treatment?

They declare they will.

This does not take into consideration the real pleasure that comes to every member of the family from having music in the home. Many homes avail themselves of hearing the best bands and the leading artists in this way. Many, however, do not, and it is precisely in these homes where the presence of music would work wonders.

Americans are traveling at too high a rate of speed in their everyday lives. They are in a chronic state of tension. Music in the home eases this condition, brings the individual to normal and thus keeps him from joining that large army of unfortunates who besiege the nerve specialist.

If they can be induced to play, so much the better. At any rate, music in the home would make things easier for them and for all those about them. There is nothing like music to tranquilize the mind and soothe the nerves.

Why not try it?

## TAKES OVER TAVERNER MUSIC CO.

Newland-Fooshee Music Co. to Continue Business as an Edison Dealer in Phoenix

PHOENIX, ARIZ., April 3.—The Newland-Fooshee Music Co., composed of Fred L. Newland and Grover Fooshee, has taken over the business of the Taverner Music Co. The announcement that Mr. Fooshee, who was formerly a partner in the Barrows-Fooshee Furniture Co., has again become interested in business in this city will be of interest to his many friends here. Mr. Newland, together with Mr. Fooshee, was associated with the Ballong-Fooshee Furniture Co. in San Bernardino, where the former was in charge of the talking machine department. In taking over the business of the Taverner Music Co. there will be no radical changes in policy and the Edison line will still be carried.

## RECORDAPHONE CO. INCORPORATED

The Schuler Recordaphone Co., Buffalo, N. Y., has been incorporated. The active capital is \$55,000 and the incorporators are A. W. J. and D. D. Schuler and E. R. Conley, Springville. It is said that the new company will make a special device to be used in recording.

The Harbour-Longmire Phonograph Co., Oklahoma City, Kan., has increased its capital stock from \$50,000 to \$100,000.



# Put Action Into the Show Window and Make It a Genuine Trade Developer :: By Courtney Harrison

A recent investigation made by a prominent talking machine manufacturer, the results of which were published in *The Talking Machine World*, showed that windows play a vitally important part in selling talking machines at retail. While this was not particularly astonishing news of itself, it was news to the degree that it demonstrated show windows are far more effective in producing sales than is commonly supposed by a great many dealers. So potent is this fact that one dealer claims that very often it would pay to lop off a bit of the advertising appropriation spent in other publicity mediums and add it to the amount contributed toward the upkeep of the show windows.

When you stop to think of it, the show window is in a class by itself as a trade bringer, and its upkeep, compared to what it can be made to produce in sales, is far below the expenditure necessary in almost any other sort of advertising. In the first place, the show window is a part of the store itself; its rent costs, practically speaking, nothing extra, and to realize this fact and accordingly be willing to spend liberally for "dressing it up" is merely jumping at the same opportunity you would hasten to grab if a quarter-page of newspaper space were turned over to you by your leading newspaper to use free of all charge every day in the year.

Then, too, the show window is a peculiarly strong and "pulling" ad because it is located right at your store. When people pass by and "read" it, your store is directly back of the window and it is the most natural thing in the world to come in and investigate right then. When people read your ads in the newspapers, on street cars and at home, they are far from your store, and though this sort of advertising is undeniably good and has its effect, a hundred different things could happen to keep readers from "getting contact" with your store a day or a week later.

These are arguments in favor of spending more on the show window set down a little differently just to make you ponder upon the big asset your windows can really be made into.

Knowing these things a great many dealers, handicapped by small or poorly constructed show windows—which for physical reasons cannot be made into anything else—deplore the fact that nothing they do will apparently put

the "pep" into their windows that they would like to have there.

I have always been glad to make a suggestion to these dealers that has been of service to them, and I pass it along to you. The suggestion is: Try to get action into each and every one of your windows. For there is nothing that will stop passers-by like action of any sort in a show window. Old as the hills, this, and yet as great a drawing card for the average American to-day as the "dollar ninety-eight" price tag continues to be. By action, I do not mean that a demonstrator must be installed in the window, necessarily, though it is not a bad idea to

*Anything That Will Take the "Stillness" Out of the Window Display Will Make It More Interesting*

do this occasionally. But what I do mean is that something should be done to take the "stillness" out of the picture your window offers to be viewed by passers-by.

An open machine, tilted a bit so that the turntable can be seen, and equipped with a replaying device to keep a record in continuous operation, will attract a person passing your window where a machine set up in straight position and silent would not, just as a moving picture will get immediate attention where a "still" thrown on the screen gets a yawn. Besides, when the little stunt is pulled that I have just outlined—and it is pulled successfully occasionally by a dealer in a western Iowa town that I am acquainted with—the music penetrates softly through the window glass and adds to the "life" of the window.

Another stunt used by a Chicago concern to stop passers-by is the placing of a row of rec-

ords of different makes upright in the window, each record being directly behind a brilliant electric-light bulb. The bulbs are strung along on a piece of 2x4 painted the same color as the floor of the window. A sign leaning against the machine in the window says "Plays all records," and through a switching arrangement supplied by any electric company, the lights in front of the records are flashed on one at a time showing that each record is a different make, and that it can be played on the machine displayed—that's the action I am talking about.

Still another retail talking machine store I know, occasionally in Summer time fixes up a window like this: In the center a phonograph is placed and a background of lattice and vines to represent a porch screen is installed. A porch swing is hung to one side of the machine and in it are installed several life-size dolls. Intertwined among the vines on the screen are numbers of red and green "streamers" of paper and two electric fans on stands back of the window are kept oscillating and blow the streamers and vines sufficiently to give a life-like appearance to the scene and to put "atmosphere" and action into it. A sign says "Keep the little folks contented and happy in Summer-time with a Victrola—fine for porch parties for the kiddies."

These are just two or three examples where action added 100 per cent to the selling powers of a window. Others will occur to you once you determine on adding zest to your windows in the future.

## DENISON GOES TO CALIFORNIA

Former Manager of Columbia Branch in Buffalo to Open Retail Store in California

BUFFALO, N. Y., April 2.—Fred A. Denison, who recently resigned as manager of the local branch of the Columbia Graphophone Co., after having been with the company for eighteen years in various capacities, has gone to California where he will open up an exclusive Columbia retail store of his own. Before leaving Buffalo, the staff of the local branch tendered Mr. Denison a dance and party, on which occasion he was presented with a beautiful gold watch, chain and charm as a testimonial of their esteem.



## Ain't He a Gosh Darn Fool!

**T**HE Kid is sure a nut this month—straw hat, fur benny and bare feet.

All dressed up for the First.

Kidding yourself on April 1st is one thing. To do it all the year 'round is 365 things, and the wise dealer knows that hard work put in on selling records gives the most satisfactory profits.

Pearsall Service is a valuable aid EVERY DAY except April 1st.



**SILAS E. PEARSALL COMPANY**

**DISTRIBUTORS**

WHOLESALE ONLY

Victrolas and Victor Records

10 East 39th Street, New York



# Victor Supremacy

The enormous public demand for the Victrola is an endorsement of its supremacy.

Victor retailers are successful because they give the public what it wants.

"Victrola" is the Registered Trademark of the Victor Talking Machine Company designating the products of this Company only.

Warning: The use of the word Victrola upon or in the promotion or sale of any other Talking Machine or Phonograph products is misleading and illegal.

Important Notice. Victor Records and Victor Machines are scientifically co-ordinated and synchronized in the processes of manufacture, and should be used together to secure a perfect reproduction.

## Victor Wholesalers

Albany, N. Y. .... Gately-Haire Co., Inc.  
 Atlanta, Ga. .... Elyea Talking Machine Co.  
 Phillips & Crew Piano Co.  
 Baltimore, Md. .... Cohen & Hughes.  
 E. F. Droop & Sons Co.  
 H. R. Eisenbrandt Sons, Inc.  
 Birmingham, Ala. ... Talking Machine Co.  
 Boston, Mass. .... Oliver Ditson Co.  
 The Eastern Talking Machine Co.  
 The M. Steinert & Sons Co.  
 Brooklyn, N. Y. .... American Talking Mach. Co.  
 G. T. Williams.  
 Buffalo, N. Y. .... W. D. & C. N. Andrews.  
 Buffalo Talking Machine Co., Inc.  
 Burlington, Vt. ... American Phonograph Co.  
 Butte, Mont. .... Orton Bros.  
 Chicago, Ill. .... Lyon & Healy.  
 The Rudolph Wurlitzer Co.  
 Chicago Talking Machine Co.  
 Cincinnati, O. .... The Rudolph Wurlitzer Co.  
 Cleveland, O. .... The Cleveland Talking Machine Co.  
 The Eclipse Musical Co.  
 Columbus, O. .... The Perry B. Whitsit Co.  
 Dallas, Tex. .... Sanger Bros.  
 Denver, Colo. .... The Knight-Campbell Music Co.  
 Des Moines, Ia. .... Mickel Bros. Co.  
 Detroit, Mich. .... Grinnell Bros.  
 Elmira, N. Y. .... Elmira Arms Co.  
 El Paso, Tex. .... W. G. Walz Co.  
 Honolulu, T. H. ... Bergstrom Music Co., Ltd.  
 Houston, Tex. .... The Talking Machine Co. of Texas.  
 Indianapolis, Ind. ... Stewart Talking Machine Co.  
 Jacksonville, Fla. ... Florida Talking Machine Co.  
 Kansas City, Mo. ... J. W. Jenkins Sons Music Co.  
 Schmelzer Arms Co.  
 Lincoln, Neb. .... Ross P. Curtice Co.  
 Los Angeles, Cal. ... Sherman, Clay & Co.  
 Memphis, Tenn. .... O. K. Houck Piano Co.

Milwaukee, Wis. ... Badger Talking Machine Co.  
 Minneapolis, Minn. ... Beckwith, O'Neill Co.  
 Mobile, Ala. .... Wm. H. Reynolds.  
 Newark, N. J. .... Collings & Co.  
 New Haven, Conn. ... The Horton-Gallo-Creamer Co.  
 New Orleans, La. ... Philip Werlein, Ltd.  
 New York, N. Y. ... Blackman Talking Mach. Co.  
 Emanuel Blout.  
 C. Bruno & Son, Inc.  
 Charles H. Ditson & Co.  
 Knickerhocker Talking Machine Co., Inc.  
 Landay Bros., Inc.  
 New York Talking Mach. Co.  
 Ormes, Inc.  
 Silas E. Pearsall Co.  
 Omaha, Nebr. .... A. Hospe Co.  
 Mickel Bros. Co.  
 Peoria, Ill. .... Putnam-Page Co., Inc.  
 Philadelphia, Pa. ... Louis Buehn Co., Inc.  
 C. J. Heppe & Son.  
 The George D. Ornstein Co.  
 Penn Phonograph Co., Inc.  
 The Talking Machine Co.  
 H. A. Weymann & Son, Inc.  
 Pittsburgh, Pa. .... W. F. Frederick Piano Co.  
 C. C. Mellor Co., Ltd.  
 Standard Talking Mach. Co.  
 Portland, Me. .... Cressey & Allen, Inc.  
 Portland, Ore. .... Sherman, Clay & Co.  
 Richmond, Va. .... The Corley Co., Inc.  
 Rochester, N. Y. ... E. J. Chapman.  
 Salt Lake City, U. ... The John Elliott Clark Co.  
 San Francisco, Cal. ... Sherman, Clay & Co.  
 Seattle, Wash. .... Sherman, Clay & Co.  
 Spokane, Wash. .... Sherman, Clay & Co.  
 St. Louis, Mo. .... Koerber-Brenner Music Co.  
 St. Paul, Minn. .... W. J. Dyer & Bro.  
 Syracuse, N. Y. .... W. D. Andrews Co.  
 Toledo, O. .... The Toledo Talking Machine Co.  
 Washington, D. C. ... Cohen & Hughes.  
 E. F. Droop & Sons Co.  
 Roht. C. Rogers Co.



Victrola IV, \$25  
Oak

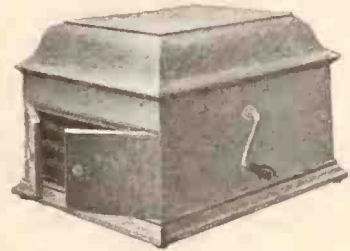

Victrola VIII, \$50  
Oak

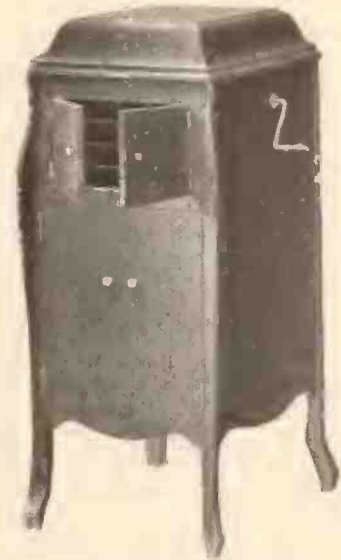

Victrola X, \$125  
Mahogany, oak or walnut



Victrola XVI, \$275  
Victrola XVI, electric, \$337.50  
Mahogany or oak

Victor Talking Machine Co.  
Camden, N. J., U. S. A.





## AN IMPORTANT ACCESSORY—ALBUMS FOR FILING DISC RECORDS

The enormous demand for "National" Record Albums keeps pace with the ever increasing demand for machines and records, and our output capacity has been enlarged to meet the greater needed supply. Record Albums have proved themselves to be the best and most convenient, as well as economic, method of filing and keeping disc records.



### MAKING THEIR SELECTION

*Illustrating the daily actual usage of the Album, the most convenient and satisfactory record filing system extant.*

### THE ALBUM

*soon pays for itself in time-saving and preserving records. The initial cost is really an investment which comes back four-fold.*

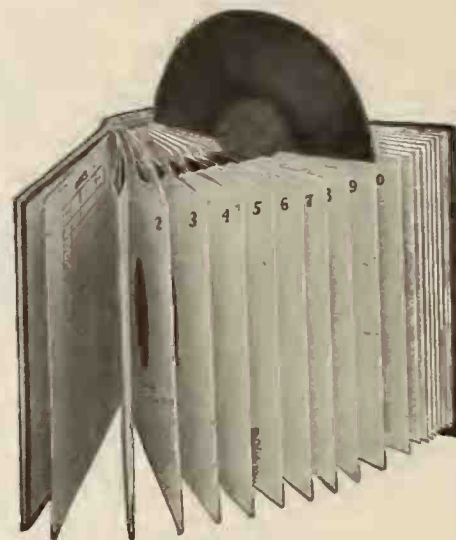

### THE PERFECT PLAN

*The pockets holding the records are substantially made from strong fibre stock, firmly joined together and bound in attractive covers.*

### A PLACE FOR EVERY RECORD AND EVERY RECORD IN ITS PLACE

Albums are an Indispensable Requisite in the talking machine business and wherever records are sold. An accessory that is necessary and worth while. Practical and handy. Save time and records. A profitable adjunct to the business. All owners of machines and records want Albums to file and preserve their records.

We manufacture disc Record Album containing 12 pockets to fit cabinets of all sizes and styles. We also make Albums containing 17 pockets. With the indexes they are a complete system for filing all disc records.

For durability, finish and artistic design, our Albums are unsurpassed. We have unexcelled manufacturing facilities, and considering quality our prices are the lowest. Write us, giving quantity you may desire, and we will quote prices.

WE MAKE ALBUMS TO CONTAIN VICTOR, COLUMBIA, EDISON, PATHE, VOCALION AND ALL OTHER DISC RECORDS

**NATIONAL PUBLISHING CO. - 239 S. American Street - PHILADELPHIA, PA.**  
**CHICAGO OFFICE: 508 S. Dearborn Street**

### ANALYSIS OF MICA SITUATION

**Increasing Demand for Quality Mica for Sound Boxes Has Assumed Enormous Dimensions—Brazil and India Main Sources of Supply—Interesting Chat With M. C. Faraci**

M. C. Faraci, president of the American Mica Works, New York City, recently outlined the mica situation of the present day in a very comprehensive manner in an interview with The World.

"Mica discs for talking machine sound boxes are very scarce, as everybody in the trade is well aware," said Mr. Faraci. "The reason for this scarcity is not because mining operations are curtailed in any manner, but is rather due to the greatly increased demand on the part of the talking machine industry. Judging from the tremendous quantity of discs which are being ordered from us, it would seem as though every man, woman and child in this country would

be an owner of a talking machine in a very short period.

"More mica is being mined at the present day in both the domestic and foreign fields than ever before, but, of course, it must be realized that the proportion of mica suitable for talking machine sound boxes constitutes only a small percentage of the amount of mica that is mined. It seems as though no matter how much mica is produced the demand in the talking machine industry still keeps considerably ahead of the production. Another phase of the mica situation which is brought to our attention is the matter of prices. Prices are going up and I look for further increases. One of the most important factors affecting the steadily increasing prices is the cost of labor. In Brazil and India, the main sources of supply, where labor was formerly obtained very cheaply, producers are experiencing the same demands on the part of labor that are evidenced throughout the entire world. The laborers in these countries

exact four times as much for the same services as they did before the war. We secure the greater part of our mica from Brazil and India. The output of domestic mica is not as yet large enough to play a very important part in filling the demand. I personally look to Africa for relief from this shortage. In that country there are extensive mica fields which will doubtless yield handsomely and which are as yet hardly worked. I am very optimistic as to the future of the talking machine industry and am perfecting plans for the years that are ahead to secure for the industry the necessarily fine quality of mica needed."

### BUILDING A LARGE PATHE TRADE

YORK, PA., April 1.—The Weaver Piano Co., Inc., Pathé distributor, reports a steadily increasing demand for Pathé machines and records with the coming of Spring. Many dealers are making canvasses with good results.

**PEERLESS**  
Metal Back Album

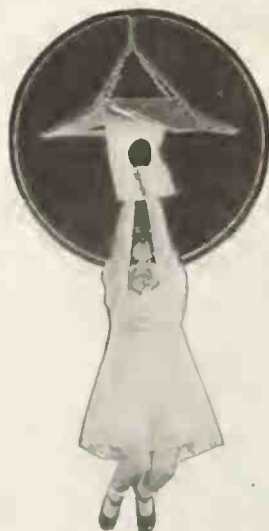

*Does it stand the strain?  
I'LL SAY IT DOES!*

## Albums Sell Records

The largest talking machine manufacturers have recognized this by equipping their most expensive models with albums—most of them using Peerless Albums.

### MR. MANUFACTURER:

Have you ever stopped to think what a beautiful and exclusive album would do towards putting your machine in the supremacy class?

## PEERLESS ALBUM COMPANY

PHIL RAVIS, President

43-49 Bleecker Street

NEW YORK CITY

Representatives: BOSTON, L. W. Hough, 20 Sudbury Street;  
 CHICAGO, W. A. Carter, 57 E. Jackson Blvd.; SAN FRANCISCO, Walter S. Gray Co., 942 Market St.

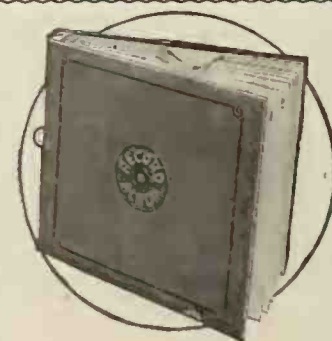

**Our Standard Grade**

*Lowest-Priced Quality  
Album on the Market*





**Victrola IV, \$25**  
Oak



**Victrola VI, \$35**  
Mahogany or oak



**Victrola VIII, \$50**  
Oak



**Victrola IX, \$75**  
Mahogany or oak

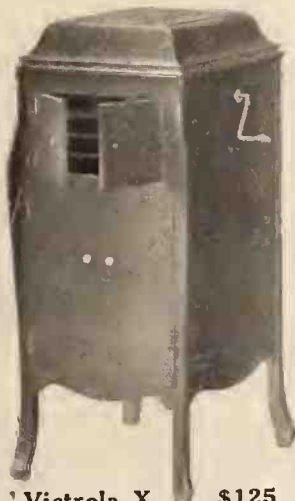

**Victrola X, \$125**  
Mahogany, oak or walnut



**Victrola XI, \$150**  
Mahogany, oak or walnut



**Victrola XIV, \$225**  
Mahogany, oak or walnut



**Victrola XVI, \$275**  
**Victrola XVI, electric, \$337.50**  
Mahogany or oak



**Victrola XVII, \$350**  
**Victrola XVII, electric, \$415**  
Mahogany or oak

# Victor Supremacy is real

It is backed by its wonderful musical achievements.

It is the power behind the success of every Victor retailer.

"Victrola" is the Registered Trade mark of the Victor Talking Machine Company designating the products of this Company only.

**Warning:** The use of the word Victrola upon or in the promotion or sale of any other Talking Machine or Phonograph products is misleading and illegal.

**Important Notice.** Victor Records and Victor Machines are scientifically co-ordinated and synchronized in the processes of manufacture, and should be used together to secure a perfect reproduction.

## Victor Talking Machine Co.

Camden, N. J., U. S. A.



# The TALKING MACHINE WORLD

For the makers & sellers of talking machines

**PUBLISHED BY EDWARD LYMAN BILL, Inc.**

President and Treasurer, C. L. Bill, 373 Fourth Ave., New York; Vice-President, J. B. Spillane, 373 Fourth Ave., New York; Second Vice-President, Raymond Bill, 373 Fourth Ave., New York; Assistant Treasurer, Wm. A. Low.

**J. B. SPILLANE, Editor**

**RAYMOND BILL, B. B. WILSON, Associate Editors**

**L. M. ROBINSON, Advertising Manager**

Trade Representatives: WILSON D. BUSH, C. CHACE, EDWARD LYMAN BILL, V. D. WALSH, E. B. MUNCH, CHAS. A. LEONARD, SCOTT KINGWILL, L. E. BOWERS, A. J. NICKLIN

Western Division: Republic Building, 209 So. State Street, Chicago, Ill. Telephone, Wabash 5774.

Boston: JOHN H. WILSON, 324 Washington Street

London, Eng., Office: 2 Gresham Buildings, Basinghall St. W. LIONEL STURDY, Mgr.  
The Talking Machine World has regular correspondents located in all of the principal cities throughout America.

Published the 15th of every month at 373 Fourth Ave., New York.

**SUBSCRIPTION** (including postage): United States, Mexico, \$2.00 per Year; Canada, \$3.00; all other countries, \$4.00. Single copies, 25 cents.

**ADVERTISEMENTS:** \$5.50 per inch, single column, per insertion. On quarterly or yearly contracts a special discount is allowed. Advertising pages, \$150.00.

**REMITANCES** should be made payable to Edward Lyman Bill, Inc., by check or Post Office Money Order.

**NOTICE TO ADVERTISERS**—Advertising copy should reach this office before the first of each month. By following this rule clients will greatly facilitate work at the publication headquarters.

Long Distance Telephones—Numbers 5982-5983 Madison Sq.  
Cable Address: "Elbill," New York.

**NEW YORK, APRIL 15, 1920**

## ADVANCED POSITION OF THE TALKING MACHINE

THE standing of the talking machine as a musical instrument *par excellence* is being exemplified in various ways these days. When one considers that more than a quarter of a century ago the talking machine was looked upon by the public merely as a toy of great attractiveness one stands amazed at the enormous growth of the industry with the recent years. The coming census of manufactures will illustrate this development by facts and figures that are bound to create considerable comment—amazement, perhaps.

Fabulous sums are invested here and abroad in the manufacture and exploitation of talking machine products, and that the industry has won a fixed and permanent place in the musical domain is evident from the marvelously faithful reproduction of sound which is possible in present-day instruments and records. Indeed, the talking machine is now recognized by its opponents of years ago as a tremendous factor in musical appreciation. Its educational power is being demonstrated in various ways—in public halls, in school rooms, in colleges and, of course, in the home.

The talking machine to-day is the culmination of years of study and experiment by inventors and scientists in all parts of the world, but more particularly in the United States. In the face of criticism and the old phrase, "It can't be done," these men concentrated on their work and have brought the technical side of the instrument to a high degree of perfection. But even this did not satisfy them and attention has been centered on the artistic side, both architecturally and acoustically. The structural beauty of each model now represents an artist's masterpiece and there are machines made to fit into all surroundings—to satisfy all tastes and fancies. Appearance has been combined with improved tone volume and quality, so that harmony of line has been made equal to the harmony of tone.

In the great campaign which is now under way the people of America are being educated to realize the practical and esthetic value of music—and this need can be very satisfactorily supplied by the talking machine, for through this medium they can have in their own homes the best that music affords. In addition, public demonstrations have made our people familiar with the talking machine, its possibilities and advantages and, consequently, have brought about a greatly increased demand for the instrument. The old doubts

and prejudices, largely due to ignorance, are being dispelled by the convincing proofs submitted by the manufacturers, dealers and salesmen everywhere.

There is no doubt that the modern talking machine has won by merit a place in the every-day life of the people, which it will never lose so long as music lives. The success of the talking machine and the industry generally is a distinct tribute to the grit and courageous spirit of those early pioneers whose undaunted determination, combined with faith in the ultimate triumph of the art, has made the talking machine industry a most vital and fascinating adjunct of modern civilization.

## INSIST ON LARGE INITIAL PAYMENTS

FOR many months past practically all merchants who have been engaged in selling on instalments, including talking machine dealers, have insisted on substantial initial payments and shortened terms to a point where accounts are cleaned up in a comparatively short few months. Thus the purchaser has an equity in the instrument at the time of delivery sufficient to influence him to keep up his payments rather than to chance the repossession of the machine with a consequent loss of at least part of the investment.

Not a few retailers, handling stock from hand to mouth, as it were, have seen no reason to encourage trade by offering any sort of instalment terms—they have been demanding cash and getting it. Those who have had experience in selling conditions in the past, however, are apprehensive, with the turning of the tide in the matter of supplies, and with stock equaling or being slightly in excess of current demands, that there may be a tendency to go back to long time and small payment instalment practices and are warning dealers to be careful. However real the danger may be, the warning is nevertheless well worth heeding. When the tide turns, the retailer may have hard work to sell, but he will need cash quite as much as he will need sales.

With his business at present on practically a cash basis, he cannot afford to take the chance of again turning to long time business without endangering his credit status. He must be prepared above all things to finance his business during any temporary period of depression that may come with unexpected reaction. He must be either independent of his bank, or be in a position to talk business in a way that the bank will like and appreciate—with collateral that is to be considered more or less liquid.

The Association of Credit Men has for some time past been carrying on a campaign urging the establishment by every business man of an adequate cash surplus or reserve to meet emergencies, or at least a reserve that can be turned into cash on short notice. The tying up of capital in long time accounts, or even in permanent improvements from which it cannot be easily released, is declared to be poor business just now. It is well enough to go ahead and expand an institution and the business it handles, but the expansion must be along conservative lines and not so extravagant that it eats up all the liquid assets of the house. A good business is not necessarily the largest, but rather the best protected.

## MAKING TRADE ADVERTISING EFFECTIVE

TALKING machine manufacturers who are already carrying on advertising campaigns in the trade mediums, as well as those who are contemplating making such a move, must have read with interest the very timely comments on trade paper advertising offered by Charles E. Byrne, of the Steger & Sons Piano Mfg. Co., which appeared in *The World* last month.

Mr. Byrne's statements are particularly valuable because they are based upon actual experience and tell of a campaign that proved a distinct success in selling talking machines as well as pianos. For the manufacturer who is in doubt as to just how to proceed in making his trade paper appropriation and in preparing copy, the article is to be accepted as a most satisfactory primer. The dominating fact is that all is not accomplished by buying space in the trade paper, regardless of how high is the standing of the medium itself. It rests with the advertiser to give thought to his copy—to make a careful study of the selling arguments that can be offered most fittingly through the medium of type—to lay out a connected and comprehensive campaign that will lead to the desired end and bring results.

It is not the novice, or the small advertiser, alone who is to be



charged with carelessness in the handling of his trade paper publicity, for there are big advertisers who are not getting proper returns in proportion to the volume of expenditure, for no other reason than that the preparation of copy does not receive the attention it deserves. Concerns who would not think of sending out a salesman with simply a business card and uninstructed regarding the details of the product he has to offer send out advertising that so far as it helps the advertiser simply gives his name and address and is absolutely devoid of selling argument.

When the product is far oversold it is quite well enough simply to keep the name of the product before the trade and the public for the cumulative effect and with a view to having the name impressed firmly upon the mind when the time comes that an extra demand may be handled. When it is desired to actually sell goods, however, it is as important, if not more important, to have the proper sort of trade paper ad as it is to give thought to daily newspaper copy. The merchant wants facts, and being experienced in the trade knows when he is reading facts and not plain hot air. The average layman, however, reading the daily newspaper may not be so sure of his ground. Telling the merchant the story and telling it in the right way is the function of trade paper advertising.

#### AROUSING AN INTEREST IN MUSIC

MEMBERS of the talking machine trade should be deeply interested with members of other divisions of the music industry in the announcement that a budget of \$50,000 has been fixed by the Music Industries Chamber of Commerce for the National Bureau for the Advancement of Music to carry on the work of that Bureau during the current year. At first glance it seems like a substantial amount, and yet the Bureau has already proven that the results obtained are of the sort that could not be purchased outright for many times this substantial sum.

The publicity for the cause of music that grew out of the Music Week celebration in New York some few weeks ago could not have been bought for \$50,000 in cash. In fact, much of the editorial comment in the newspapers could not have been secured at any price. And it must be remembered that it was the National Bureau for the Advancement of Music that started the campaign, and while keeping its identity in the background saw to it that the details were carried out successfully.

Talking machine men should be interested quite as much as the piano men in any movement calculated to arouse a more general interest in music—more so, in fact, because in many respects the talking machine has been recognized as a pioneer in bringing to the masses of the country their first or greater knowledge of the better things in music. The fact that more attention is constantly being given by the newspapers to music, particularly in its more popular form, and that in giving this attention the importance of the talking machine and player-piano is not in any sense overlooked, is serving

to arouse in the hearts of millions an interest in, if not a longing for, some form of music in the home. In the great majority of cases this demand is fully met by the talking machine. To sum up, the advancement of music means the advancement of the music trade, although indirectly, and for that reason everyone engaged in selling talking machines should take a personal interest in the movement.

#### THE IMPORTANCE OF GOOD SALESMANSHIP

MEN who have entered the talking machine field from other lines of business or who have given more or less study to the distributing branches of the trade have maintained that to all intents and purposes salesmanship in the retail branch of this industry is practically a lost art, with a few notable exceptions. Such statements have not been made in the sense of reflecting upon the progressiveness of the trade, but rather to emphasize that conditions generally have not demanded the development of the selling sense to any pronounced degree.

There have been good salesmen in the trade and there still are whose success has been noteworthy, but the rank and file have been satisfied to depend upon the advertising of the manufacturer and their own publicity to take care of new business, with clerks of the ordinary type to fill the customer's orders in the store proper. There are some factors in the trade who have already sensed that there is right now a need for more skilled salesmanship and that this need will increase as time goes on. These factors in turn have set about solving the problem and the result has been the establishment of a number of schools in salesmanship where facts replace theory in the instruction of the students.

Good salesmanship can do much to offset the effect of the record shortage by placing with the public records not generally advertised or not cataloged prominently. Good salesmanship demands that the salesman know about these records and be ready to talk about them convincingly. In other words the need of more advanced salesmanship is apparent and various schools and classes have been established with a view to meeting the situation. This is a move that is going to prove valuable before many months have passed.

#### RECORD DEMAND STEADILY EXPANDING

A DEMAND for records that is absolutely unprecedented is a notable feature of the trade these days and the best efforts of manufacturers seem unable to satisfy the needs of the jobbers, the dealers and the public. The call is not wholly for records of the popular compositions, inasmuch as the recordings of the great vocal artists and leading instrumentalists are demanded in a way that is simply amazing in its volume and persistency. While shellac and other materials entering into the manufacture of records are still scarce and tremendously high in price, larger shellac supplies with downward price tendencies are looked for, which may bear on increased production.

**Ormes**  
**Really**  
**Means**  
**Exceptional**  
**Service**



“The power of co-operation is man's highest manifestation of intelligence and wisdom.”

*Elbert Hubbard*

**ORMES, Inc.**

26 East 125th Street

NEW YORK

*Victor Wholesale Exclusively*



# There Is a Sale for Every Record Made Provided It Is Rightly Sold :: :: By W. E. Standke

I was recently asked to express myself regarding records that move slowly and for which there is little demand. I have given the matter considerable thought and it is my honest belief that there is a sale for every record that was ever made. But it depends almost entirely upon the salesman to find those sales. Every shop has a percentage of trade that is steady and the steady trade of any shop is so widely different and variable that it calls for almost the utmost on the part of the salesman to cater to that trade with some degree of intelligence. There are those who buy only heavy compositions, such as grand opera records; others desire a majority of the humorous selections.

"Too many establishments have taken the attitude that their customers should know what they want before they come to buy; that they should have some idea from the new catalogs and supplements of what they would like to hear, and hence know what to ask for. This is hardly true of any division of the record purchasers, but it is up to the salesman to discover how best he can meet the trade and best cater to it.

"We will first consider the class which buys grand opera records. This is in many instances considered the educated class and the amateur salesman has a general idea when he has such a customer that the customer knows just about what he wants and can ask for it right off the bat. This is just as great a mistake as it would be for the dealer to catalog the customers who usually demand light music and dance numbers as less educated than the first class. After years of experience I have found that even those customers who have a liking for the

heavier compositions are apt to forget some beautiful classic that might be of a comparatively old recording. However, the salesman with a knowledge of his stock and who can judge the type of music suited to his customers can make sales of a pleasing nature and keep his entire catalog moving continuously. For instance, a transient customer may visit the store

*Salesmen Who Know  
Their Stock and Can  
Judge Customers' De-  
sires Can Keep the  
Catalog Moving.*

to-day and ask to hear several records played and the salesman, while demonstrating the records, may have some particular one called to his attention that would just suit Mrs. Brown, (Mrs. Brown, of course, being one of the steady customers). The wide-awake salesman will either make a mental note of the record or place it, if the stock permits, in such a position that he can find it quickly. The prime feature is that he must not forget it.

"It may seem absurd to some that such a system can be worked out in a large establish-

ment with any degree of success, but because I have applied it I know that it can. Often it may happen that when the particular customer arrives the salesman is busy with another customer, but there are various ways that the record he has selected for that customer may be called to her attention. This, too, has caused another feature in the trade and that is the habit a customer develops of asking for a certain salesman or saleslady. The careful manager will note that this is because the customer has come to rely more or less upon the salesman."

## NEW VICSONIA DISTRIBUTORS

Wholesale Representatives Appointed for the Pacific Coast and for Pennsylvania and Neighboring States—Big Increase in Sales

In order to insure the many talking machine dealers handling the Vicsonia the maximum of service in the matter of filling orders the Vicsonia Mfg. Co., Inc., New York, is constantly adding to its list of distributors in various sections of the country. Among the recent exclusive distributors appointed by the company are the Pacific Accessory & Supply Co., Portland, Ore., for the entire Pacific Coast, and Newton B. Heims, of Pittsburgh, Pa., for the States of Pennsylvania, Ohio and West Virginia.

The demand for the Vicsonia, and particularly for the new Model "B," is developing rapidly and W. J. Sess, head of the company, states that sales have increased 200 per cent during the past six months. The company is having no trouble in the matter of production and is, therefore, able to fill orders promptly.



Style A

*Dulcitone*

Dulcitone Walnut, Rich Mahogany,  
Red or Brown

# Dulcitone

Tone    Appearance    Superiority

The wonderful tone of the Dulcitone is not an accident, but the result of right development of known principles governing tone production. The especially constructed tone chamber, embodying proper dimensions, shape and quality of material, is the medium by which tone once properly started in the reproducer is amplified and brought out full, clear and rich.

Dulcitone appearance is one of the prime factors in its popularity. Veneered in beautifully matched genuine Walnut and Mahogany veneers, it appeals instantly to the eye and commands admiration. DULCITONE WALNUT IS THE MOST BEAUTIFULLY FIGURED AND PERFECTLY MATCHED VENEER IN THE ENTIRE PHONOGRAPH INDUSTRY.

The combination of wonderful tone and incomparable beauty of finish places the Dulcitone at the head of the list of all Phonographs and explains its unquestioned popularity with both dealer and customer.

Write for prices and further interesting information.

PROMPT SHIPMENTS.

## Dulcitone Phonograph Company

Chicago Office, 404 Republic Bldg.

SOUTH HAVEN, MICHIGAN





THE  
BRUNSWICK-BALKE-COLLENDER  
COMPANY

General Offices: 623-633 S. Wabash Ave., Chicago

Branch Houses in Principal Cities of United States,  
Mexico and Canada

Canadian Distributors: Musical Merchandise Sales Co.,  
819 Yonge St., Toronto





The Ultona Playing a Brunswick Record

## Why people prefer The Brunswick

Brunswick has won its everlasting position in the music world, not merely by filling a temporary need, but by a big vision plan.

First came improvements, such as the Ultona and the Brunswick Tone Amplifier. And many more new-day developments.

These met with instant approval. Brunswick led the way in all-record playing. The Ultona showed people that a fine phonograph could play all records—that one need not be confined to one make of record.

Remember how we blazoned "The Brunswick Plays All Records" across the country. We brought it out as a new idea. It created a sensation.

Now, of course, many phonographs play all records. But none have equaled

the Ultona, an exclusive Brunswick feature, because it is a Brunswick invention.

Another appeal that won approval was the finer tone. In the Brunswick Method of Reproduction, which combines all tonal factors, we brought new standards.

Part was due to the Brunswick Oval Tone Amplifier, built entirely of wood. That was an innovation. The old-time practice was to connect tone arm and amplifier with a cast metal throat.

The Brunswick way ended harsh, strident notes. And people quickly realized Brunswick superiority.

These are some of the many reasons for Brunswick popularity. And they are factors not merely of today but of tomorrow. They insure the Brunswick dealer a permanent, growing business.

THE BRUNSWICK-BALKE-COLLENDER COMPANY

General Offices: 623-633 S. Wabash Ave., Chicago

Branch Houses in Principal Cities of United States, Mexico and Canada

Canadian Distributors: Musical Merchandise Sales Co.,  
819 Yonge St., Toronto

# Brunswick

PHONOGRAPHS AND RECORDS



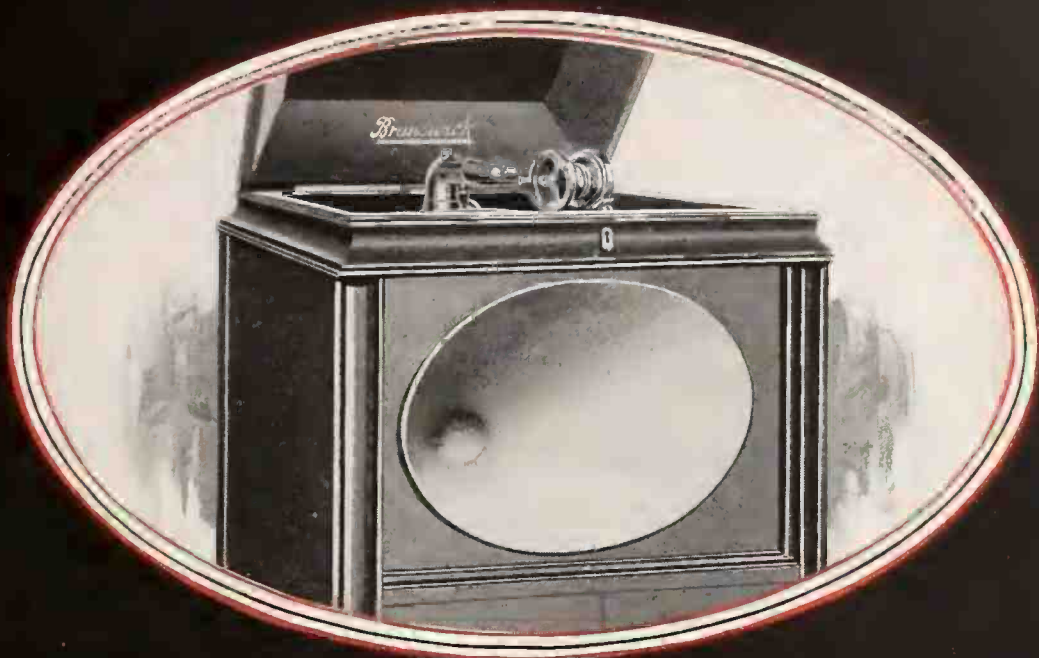

**The Tone Amplifier Built Entirely of Wood**

## Why The Brunswick is in such demand

The House of Brunswick is wise in planning first to please the critical customer. In The Brunswick it gives a superior instrument.

But larger wisdom is shown by Brunswick advertising. It tells the Brunswick story in a vivid, appealing manner. It has acquainted the millions with the Brunswick betterments.

It sends people to Brunswick dealers. People want to know the facts.

For all Brunswick advertising arouses curiosity. It tells people to make comparisons. It advises people to hear The Brunswick, then others. It says that people will quickly realize the tonal beauties of The Brunswick.

The Brunswick advertising concentrates on the Ultona and the Brunswick Tone Amplifier. It makes people want to become acquainted with these features.

One of the first principles of salesmanship is to arouse curiosity. And that is the keynote in all Brunswick advertising. That is what makes it so valuable to Brunswick dealers.

We invite you to study Brunswick advertising. It is backed by one of the largest appropriations. It is written to sell Brunswicks. We think it is the finest phonograph advertising in the field.

And we know that it helps Brunswick dealers because they constantly tell us so.

THE BRUNSWICK-BALKE-COLLENDER COMPANY

General Offices: 621-633 S. Wabash Ave., Chicago.

Branch Houses in Principal Cities of United States, Mexico and Canada  
Canadian Distributors: Musical Merchandise Sales Co.,  
819 Yonge St., Toronto

# Brunswick

PHONOGRAPHS AND RECORDS



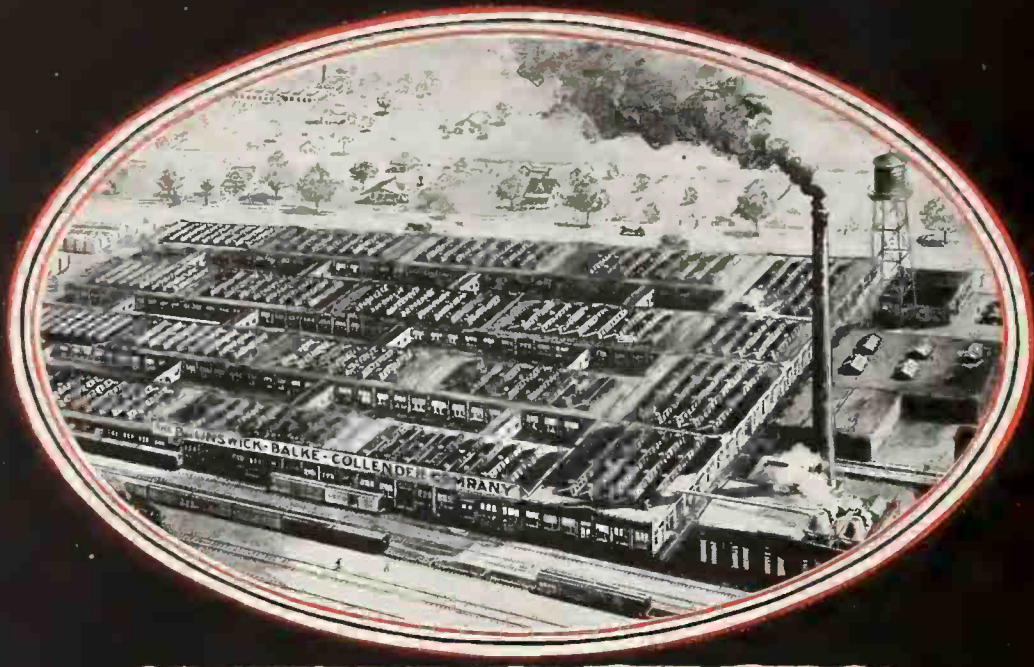

Brunswick Phonograph Factory at Dubuque, Iowa

## Brunswicks are built complete by Brunswick—not assembled

Maybe you do not realize it, for it has come about in the last three years, but Brunswick is now one of the foremost builders of phonographs in the industry.

In fact, the Brunswick factory is one of the finest, one of the most complete, one of the most efficient production bases to be found.

Brunswick is now one of the very few builders making its product *complete*. The general practice is assemblage.

We know of only one other phonograph maker having as complete a plant as Brunswick.

Brunswick has risen to this place in but a fraction of the time it took to build other businesses.

This is not said boastfully, but to acquaint phonograph dealers with the phenomenal reception given The Brunswick by the people.

We tell you also to show how sincerely the House of Brunswick goes into a proposition. The House of Brunswick has built its immense factories for the future. Brunswick has won a commanding place, and we intend to hold it.

We build our own motors, our own cabinets, our own Ultonas—every part, every feature. We are not dependent upon parts makers. We control every standard, every inspection. We do not have to compromise on quality.

Brunswick success is growing constantly. It hasn't reached our height yet. The momentum is carrying Brunswick on, and we are adding to that momentum by far-vision plans.

Thus we insure an enviable place for the Brunswick dealer. His franchise is becoming more and more valuable every day.

THE BRUNSWICK-BALKE-COLLENDER COMPANY

General Offices: 623-633 S. Wabash Ave., Chicago

Branch Houses in Principal Cities of United States, Mexico and Canada

Canadian Distributors: Musical Merchandise Sales Co.  
819 Yonge St., Toronto

# Brunswick

PHONOGRAPHS AND RECORDS



# Widespread Rebirth of Musical Interest in America Is Helped by the Talking Machine

Probably the most comprehensive and enlightened view of the present musical status of the American public and also of the part that has been taken by the talking machine in bringing about a more general appreciation of music among the American people that has yet appeared in the public press was found in a lengthy editorial in the New York Tribune of recent date under the caption: "Are Americans Musical?"

The editorial, which had its inception in the general success and wide influence of the recent Music Week in this city, agrees with certain critics that there is an undoubted lack of widespread musical training, technically speaking, in the country, and that we are neither a singing nor a playing people. It admits that the American home heard little of music until recent years and that where there was music it was of the crude sort, usually represented by the elementary playing of the son or daughter on this or that instrument.

The interesting feature of this editorial is the frank credit paid to the influence of so-called mechanical music in giving Americans a new and more intimate aspect of music generally. Following a discussion of the various criticisms, the editorial says:

"These criticisms are all true, and yet the concert record of New York is not an isolated and unrepresentative fact. To the contrary, it is a true indication of a widespread rebirth of musical interest in America, due entirely to the mechanical music so foolishly disdained by some musicians. It is not with a musical country like Italy that America of to-day is to be justly compared. The fair comparison is with America of

a generation ago. Any such checking up will reveal the very real progress which Music Week is recording wherever it is held.

"The supercilious folk who suspected 'canned' music of all sorts of evil influences lacked faith in their art, as a matter of fact. There is only one way to develop taste in any art, and that is by saturating one's self in it. To learn rules,

*There is Really Only  
One Way to Develop  
Taste in Any Art and  
That Is by Saturat-  
ing One's Self in It*

or hear an occasional concert, or memorize a few pieces on a piano after years of disagreeable endeavor, is not to become musical. The beauty of the talking machine and the player-piano, artistically speaking, was that they laid down no rules whatever. They simply filled the American home with music—good, bad, indifferent, as the taste of the owner elected. Taste does not remain stationary, however. There would be no progress in any art if it did. Music develops its own standards; it improves ears, comprehension, taste, as it goes along. That is

the experience and testimony of everyone who has watched the progress of mechanical music.

"The development of community singing is an interesting by-product that confirms this view. So in its way is the revival of dancing. And, best of all, here, as throughout this whole renaissance of music in America, pleasure is the motive and goal of those who participate. We should rate this as the most important fact in the present rise of America from being one of the least musical countries toward, we hope, becoming one of the most musical. We are not taking our music sadly, as a painful duty to the gods of uplift. We are listening and singing and playing because we enjoy it. This is as music was intended. We may have still a long way to travel. But we are on the right road."

This editorial again brings to attention the new and pleasing attitude of the newspaper press toward the great campaign for musical advancement inaugurated by the music industry and affords a convincing argument as to the worth and value of music which can be used effectively by the talking machine dealer and by advocates of music generally. Editorials such as this are well worth reprinting by members of the industry, not alone because of their business-getting value, but because their intrinsic worth warrants their receiving the widest possible circulation.

The Carroll Music Store, Appleton, Wis., has purchased the former post office building in that city and possession will be taken in a few months. At that time the stock of Victor talking machines and records will be transferred from the present location at 874 College avenue.

## Do you want these good Customers?



Playing hill-and-dale record

Edison Owners are good Customers for YOU if you sell them the

### KENT Master Adapter

The illustrations show how it is instantly adjusted to play ANY kind of disc record.

And when these Customers, come back for more and more records they'll tell you that the "Kent Master" plays each record *at its best.*

That pleases *them* and pays *you.*



Playing lateral-cut record

May we tell you about it?

Here is another message to  
**DEALERS and MANUFACTURERS**

Besides the Kent Master Adapter we manufacture several other attachments for Edison and Victor Machines, as well as Tone Arms and Sound Boxes. When you know about these you will agree that they "*Win their way by their play.*" Furthermore, we carry large stocks of steel, sapphire and diamond points.



Registered in U S Pat Office

## F. C. KENT COMPANY

Mulberry and Chestnut Sts.

Newark, N. J.



# The Only Non Set Automatic Stop

This long-wanted improvement is now a part of the new Columbia Grafonola. Built right into the motor. Invisible. Automatic. Operates on any record, long or short. Nothing to move or set or measure. Just put on your record and the Grafonola plays and stops itself.

No other phonograph has it. All other stops must be set by hand for every record. No other phonograph can get it. Basic patents protect the Columbia Non Set Automatic Stop. It is the last touch of comfort and convenience added to the greatest of all musical instruments, the Columbia Grafonola.

*Exclusively on the*  
**Columbia**

COLUMBIA GRAPHOPHONE COMPANY, NEW YORK

---



## *A Great Selling Point of Columbia Grafonolas*

Your customers cannot resist that last touch of convenience which the Non Set Automatic Stop gives the Columbia Grafonola. Always tell them all about this *exclusive* Columbia feature. Demonstrate it in your store and see the number of sales it clinches. We have already told its advantages to more than twenty-one million people in the current magazines.

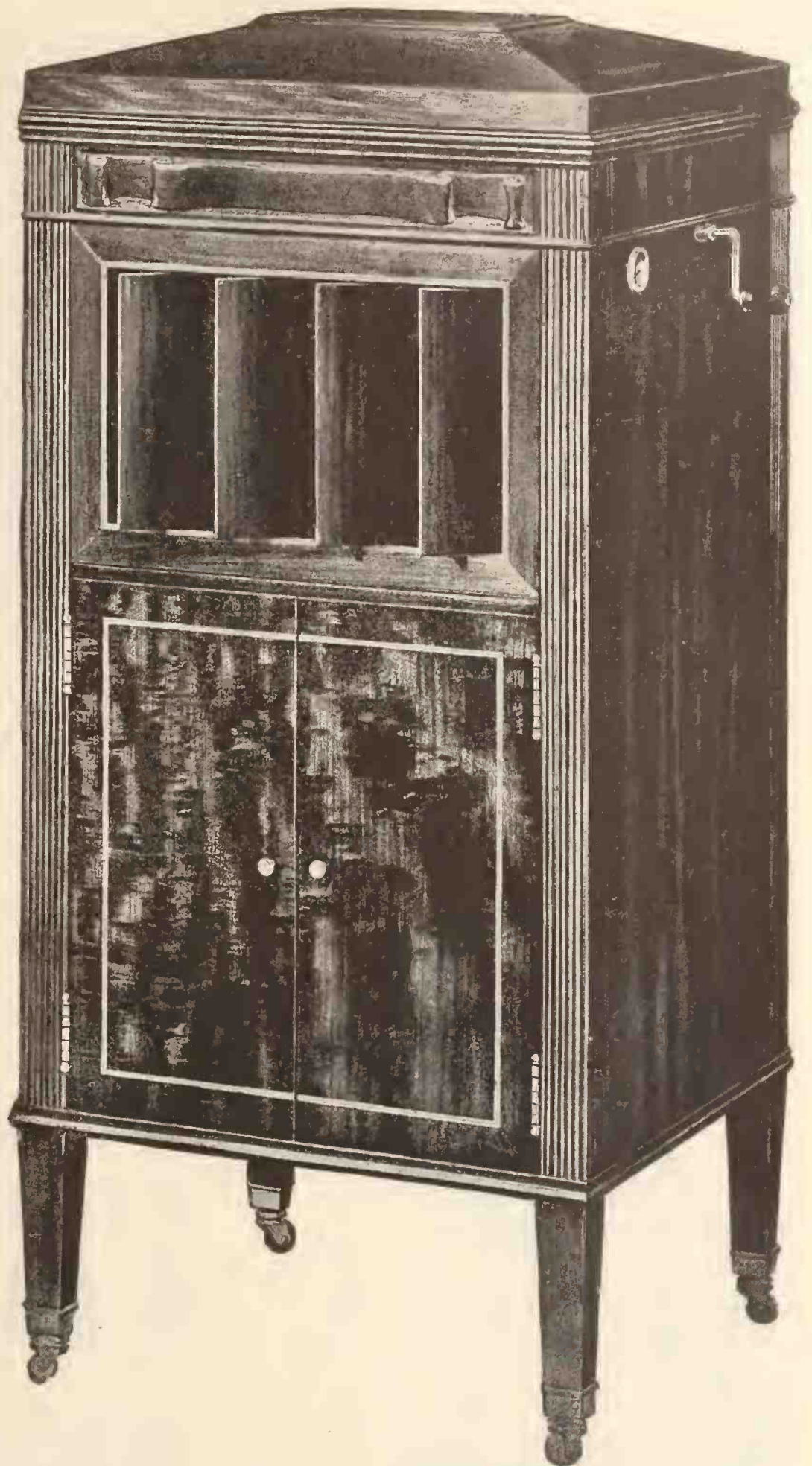

# Grafonola

COLUMBIA GRAPHOPHONE COMPANY, NEW YORK



# Strain



## AVOID IT!

**D**ID you ever hear a table groan as it was pushed across the floor? It's a plea for better treatment.

Strain is the arch enemy of good furniture. It splits joints and mortises, cracks glue, makes legs wobbly and militates against sales in the show room and the customer's satisfaction with her purchase at home.

But strain in all its ill effects can be avoided by using

# DOMES of SILENCE

They cost little, their efficiency is high, and they free dealers and housewives from worry. They are made of case hardened steel and are as easy to put on as they are simple in construction.

Most furniture manufacturers equip their products with Domes of Silence. They are just as much a necessity as a selling argument.

**HENRY W. PEABODY & CO.**

Domes of Silence Division

17 STATE ST.

NEW YORK



*The above is an example of the vigorous national advertising appearing in a long list of the best consumer magazines. This, in addition to the many million sets already in use, has taught the public to expect these slides on their furniture.*

IN ALL YOUR FURNITURE ORDERS

# SPECIFY DOMES OF SILENCE



# Interesting Comments on Various Phases of Talking Machine Progress :: By W. Bliss Stoddard

How to get the man interested in the talking machine is a problem that presents itself to every dealer. Most men have their music, like their religion, in their wife's name, and when it comes to buying an instrument of any kind say, "Oh, go on and get what you want—I wouldn't know anything about it anyway." Of course they criticize the selection after it is made—but that is merely masculine nature. The Mackay Furniture Co., St. Louis, Mo., however, solved the problem of how to get men into the store—and alone at that. This they did by sport bulletin boards. They arranged with one of the newspapers for a telephone service regarding leading football games in the Fall, boxing matches in the Winter, while this Spring they will have the baseball news. On the platform with the board they have a first-class talking machine, and between the scores and points they give a program of the best music, both classical and popular, in order to appeal to all tastes. As a result of this novel method of advertising eighteen talking machines were sold within two weeks, to say nothing of the scores of records that were purchased. Many of the men who dropped in to hear and see the returns had Victrolas at home, and after they had heard an air that struck their fancy several times they were pretty sure to inquire about the record. A clerk was always on hand at the record counter—and although no effort was made to sell either talking machines or records they sold themselves by their mere presence.

## What a Western Druggist Thinks of the Talker

In the West they are not so afraid of innovations as in other sections of the country, and as a result most of the better class of druggists

are stocking with a good supply of talking machines and records, recognizing that it is a line which is constantly increasing in popularity. It is therefore interesting to hear what one of the druggists in one of the smaller progressive cities of the Western Coast has to say on this subject. E. R. Howell, of Pullman, Wash., said recently:

"To-day the talking machine is one of the ideal side lines for the drug store. I have known some of the old-timers of the drug trade to look aghast at the idea. To these I come back with the fact that music has a definite therapeutic use, and the Victrola has even been used as an adjunct to the operating room. With what other side line can you turn a sale in from fifteen to thirty minutes that will show a very substantial profit? I have taken a new prospect to the Victrola balcony, showed the advantages of the various sizes, and closed a \$130 sale, while a fellow salesman was trying to sell an uncertain damsel a 50-cent box of powder. Most likely I would arrive on the scene in time to hear her say, "Charge it, please!" The purchaser of the powder might return for other purchases and she might not. The Victrola purchaser is a tangible good-will asset. He will return many times, eventually averaging \$50 for purchases of records.

"One of the fundamentals of success in handling talking machines, as I see it, is the selection of a quality line—and I would suggest an advertised line whenever possible. A customer may take a bottle of perfume on your recommendation, but when he is sinking from \$100 to \$200 in a talking machine he wants additional assurance in most cases. Don't con-

tract for a line that gives 10 per cent. profit over the margin you would receive on the best line you can secure—as the better line may yield four times the sales and a net profit far exceeding the other. In other words, get the very best line you can and then push it for all you are worth."

## Old Customers' Week

There is a prestige which comes from long establishment of which every merchant should take advantage. It was with this idea in mind that James Hart & Sons, Long Prairie, Minn., determined to use their long location in the town not only to hold their old, but to obtain new customers.

They accordingly inaugurated an Old Customers' Week, when they invited all their old customers, people who had traded with them ten years or more, to visit them. They wrote letters to sixty or seventy of the older residents, asking them to give their recollections of the inception of the talking machine business, and when they first remembered hearing the little phonographs with horn attachment played in the Hart store. They also asked these old settlers, as a favor, to send their photos and a note telling how long they had traded at the store, and what was their general impression of it. The response was decidedly gratifying. About 75 per cent of the people replied and the great majority sent their photos. The letters and pictures were published in Hart's Rinkels—their monthly store publication. Some of them were very interesting, showing people 80 years of age and over who had traded with the firm for more than a quarter of a century. Their recollections of the birth of the talking machine and the wonderful progress that had been made since then focused the attention of all readers on these products—and, of course, the firm was wise enough to see to it that there were several good cuts of the latest models run in this particular edition.

## Talking Machines Were the Attraction

During Old Customers' Week there were displayed in the salesroom models of talking machines from the first crude specimen to the present human tone instrument. They were the magnet that drew old and young, and when some of the younger generation talked with the old inhabitants and learned of the long years of fair dealing of the firm, as related by them, they gained the idea that it was a pretty good place at which to trade—which was precisely the object of inaugurating the week. Another illustration of the fact that a satisfied customer is the store's best friend.

## BROOK MAYS & CO. ORGANIZED

Branch of D. H. Spencer & Sons Formed to Distribute Mandel Phonographs in Southwest

DALLAS, TEXAS, April 2.—D. H. Spencer & Sons, of this city, have established a new wholesale phonograph department to distribute the Mandel phonograph in the Southwest. This department is known as Brook Mays & Co. and is under the direction of D. H. Spencer, 105 South Murphy street. At the present time a large line of Mandel phonographs is carried and it is the intention of the firm to add a stock of records, parts and accessories.

## "ANGELICO" IS INCORPORATED

A new talking machine house has been incorporated under the laws of New York State to do business in Brooklyn under the name of Angelico. The capital is \$30,000 and the incorporators are W. J. Hollister, P. L. Greiner and J. L. Cooke, 13 Middagh street, Brooklyn.



## Better Advertising—"The Victrola Visitor" and Other Features

WE believe that every real Victor merchant needs distinctive advertising—something that is unlike the advertising of his competitors, no matter how cordial his relations with fellow-merchants may be.

And so, a part of our program is to provide attractive advertising that contains much in small space.

Ask us for proofs of special newspaper advertisements, about the new prices on Red Seal Records, quick delivery of purchases, and No. IV and VI Outfits; also for a copy of "The Victrola Visitor"—a unique house-organ booklet for dealers who maintain live mailing-lists.

If you haven't seen the first issue of *The Victor Turnover*—our Dealer Bulletin—we'll be pleased to send a copy.

THE CLEVELAND TALKING MACHINE CO.  
1125 Oregon Avenue, Bingham Building, Cleveland, O.



# Four New Ways of

*For the Manufacturer*

## Eleven Amazing Features of New COPPER Tone Arms

Only one manufacturing process yet discovered can successfully produce this wonderful product, the *copper* tone arm. Only one man in the world ever learned this secret process. Only one plant on earth has the right and the facilities for fabricating copper this new, secret way.

Through a wonderful new secret process of fabricating copper into any shape desired, talking machine manufacturers are now offered the opportunity of obtaining the fruits of this invention for their own priceless benefit. Copper Process Tone Arms possess eleven amazing features which no phonograph manufacturer can afford to ignore. And not least of all is the fact that any design required can successfully be produced, very quickly and in whatever quantity desired.

Below are listed briefly these eleven features. Every manufacturer will immediately realize their immense importance both from a production standpoint and from the advertising and selling angle. The coupon on the opposite page will bring you full information about this *copper* tone arm. Mail the coupon at once if you are a manufacturer looking for a product which will transform both the appearance and the performance of your phonograph.

### Isn't Every One of These 11 Features of Big Importance to You?

- (1) Greater manufacturing *speed* and *production*.
- (2) Adaptable to any design you submit—through new secret process of fabricating copper.
- (3) No liability of breakage. Could hammer it flat, same way as gold, without its breaking.
- (4) No possibility of imperfection in manufacture.
- (5) No peeling of the plating.
- (6) Lighter in weight.
- (7) Smaller assembling costs.
- (8) No leakage—seamless copper arms specially moulded or of our regular stock designs.
- (9) Can be brought to a higher polish.
- (10) Produces better tone—more natural, mellow and full.
- (11) Real advertising and selling strong points which will prove just as evident to and effective with your dealers as with their customers.



C O N D O N ' S      S U R E T Y      E X P R E S S



# Boosting Profits

and for the Trade—



## The Steel Needle With the Ball Point

Torrington Uniform Needles are the only steel needles made with the ball point. That harsh, grating scratch which costs dealers so many phonograph and record sales is eliminated. Tone value is improved and each shading of sound in the recordings is reproduced perfectly.

### EACH NEEDLE UNIFORM

Each Torrington Uniform Needle is exactly the same as another. Through a special method of manufacture all needles are made perfectly uniform—in size, finish, tone value and merit. You could line up a million Torrington Uniform Needles and not a hair's breadth of difference would there be between them.

Don't rob yourself of your own rightful profits by supplying your customers with the sort of needles which discourage record and machine sales. Let us send you some samples of Torrington Uniform Needles—then judge for yourself! Our Plan K will interest you. The coupon will bring you samples and this special plan.

## How GROOVITE Sells More Records

"Groovite" is increasing record sales of hundreds of dealers because it makes every record the customer hears "taste like more." This wonderful new liquid cleans each record groove as the needle goes over it—and improves the record tone over 30 per cent.

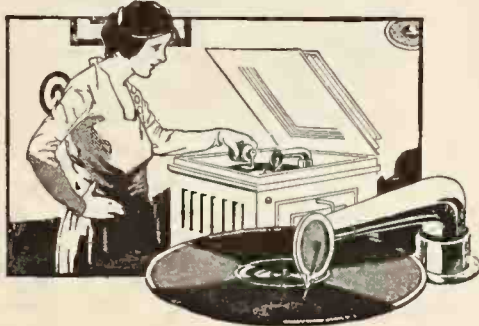

No mess or trouble in using "Groovite"—altho the difference in results would be well worth it. It is a liquid which runs around the grooves, absorbing and dispelling all the tone-killing dust and grit particles, and making each groove as

clean as a whistle—enabling the needle to bring out over 30 per cent more sweetness and purity of tone.

### Mail Coupon for Special Proposition

This coupon, mailed promptly, will bring you full information about our special proposition on "Groovite." Learn how "Groovite" boosts record sales for those who sell it. Let us tell you more about "Groovite" and our special proposition.

## The New Kind of Cabinet Polish

What is the biggest point about this new cabinet polish which is meeting with such favor from dealers and consumers? Why is "Gliss" being called, "the polish that makes the dealer the customer's friend"?

The one big point about "Gliss" that is winning so much favor is the fact that—the luster lasts. Not only does it produce a bright, glistening luster—but the polished surface stays that way. A special chemical compound insures this amazing result.

"Gliss" is being used in thousands of households for polishing the finest fur-

niture and is guaranteed absolutely free from injurious substances.

Fill out the coupon and mail it at once. Learn more about our special plan of marketing this new kind of cabinet polish. "Gliss" is made so that your customers are pleased with their purchase—and marketed so that you are pleased with your profit. Mail coupon to-day for full information about it.

(COUPON)

CONDON & Co., Inc.,  
200 Fifth Avenue, New York City.

Please tell us more about  Copper Process  
Tone Arms,  Gliss,  Torrington Uniform  
Needles,  Groovite. I understand, of course,  
that this request obligates me in no way.

Name .....

Address .....

City .....

MAIL COUPON AT ONCE TO  
**Condon & Co., Inc.**  
200 Fifth Avenue  
NEW YORK



The Line to Greater Profits





**Charles Hackett's first record in English is that beautiful love ballad "I'd Build a World in the Heart of a Rose." Columbia Record 78929.**

**Columbia Graphophone Co.  
NEW YORK**

**THE MAGNIFICENT BRUNSWICK DISPLAY AT THE NATIONAL MUSIC SHOW IN NEW YORK**



This Artistic Exhibit So Much Admired by Visitors to the Recent Music Show Also Marked the First Presentation of Brunswick Records

**AEOLIAN-VOCALION IN MANISTEE**

MANISTEE, MICH., April 2.—J. and A. J. Piotrowski, of this city, who have for some time past been retail merchants handling the Pathé phonograph and records, have recently added Aeolian-Vocalion phonographs and Vocalion records and are displaying a very fine stock.

**MUSIC HALL FOR CANTON STORE**

Klein & Heffelman Co. Building Auditorium in Store Building for Use of Musicians

CANTON, O., April 5.—An innovation in Canton music stores is announced by the Klein & Heffelman Co., which will install a music hall in the new store now in process of construction on Market avenue North. The music hall will be independent of the music department and will serve several purposes. Local musicians and students of music will be permitted to give recitals there instead of engaging an auditorium. The music hall will have a large stage, attractively designed, and special scenery will be provided. The company will encourage private recitals and an adjoining room will be fitted up where refreshments will be served.

**NEW CONCERN IN CANTON, O.**

The Woomer Phonograph Co. to Specialize in Retailing Talking Machines

CANTON, O., April 2.—The Woomer Phonograph Co., Canton's newest music concern, has been incorporated at Columbus, O., with a capitalization of \$5,000. The officers of the company are S. C. Woomer, president; E. H. Woomer, vice-president and general manager, and V. A. Woomer, secretary and treasurer. The firm plans to remodel its present place of business at 123 Cleveland avenue S. W. and will handle several of the leading makes of phonographs. Approximately 1,000 square feet of space will be added to the present quarters when the store is remodeled and the most improved form of equipment installed.

REGINA

Phonograph



Plays all disc records with an unusual clearness, richness and beauty in tone.

*Attractive Proposition for active Dealers*

The REGINA Co.  
47 W. 34th St.,  
New York

209 S. State St.,  
Chicago

AUTOMATIC STOPS

The simplest and most efficient Automatic Stop on the market. They give excellent service, are easily installed and are absolutely guaranteed.



*Send 50 cents for Sample Stop*

**Kirkman Engineering Corporation**  
484-490 Broome St., New York





## Eighth Supplement

Ready Soon

# Okeh Records

### LATERAL CUT

- 4079 { I'LL SEE YOU IN C-U-B-A—Tenor, with Rega orch.,  
10-in. Billy Murray  
\$1.00
- 4081 { SEE OLD MAN MOON SMILE—Baritone duet,  
10-in. Al. Bernard-Ernest Hare  
\$1.00
- 4082 { ALL I WANT IS YOU—Tenor, with orch.....Henry Burr  
10-in. WHEN MY BABY SMILES—Baritone, with orch..Bert Franklin  
\$1.00
- 4083 { OLD FASHIONED GARDEN—Tenor, with orch.....Sam Ash  
10-in. VENETIAN MOON—Baritone, with orch.....Joseph Phillips  
\$1.00
- 4084 { MELODIOUS JAZZ—Vocal Quartette, with Rega orch.,  
10-in. Peerless Quartette  
\$1.00
- 4085 { HE WENT IN LIKE A LION AND CAME OUT LIKE A  
LAMB—Tenor, with orch.....Billy Murray

- 4080 { MY ISLE OF GOLDEN DREAMS—Waltz, Saxophone  
10-in. sextette.....Joe Thomas' Sax-o-tette  
\$1.00
- 4085 { IN AND OUT—One-step, Saxophone sextette,  
Joe Thomas' Sax-o-tette
- 4086 { SEE-SAW (Intro.: "When Two Hearts Discover," from  
10-in. Musical Comedy, "See-Saw")—Fox-trot,  
\$1.00 Green Brothers Xylophone Orchestra
- 4087 { KORINTHIA—One-step,  
Joseph Knecht's Waldorf-Astoria Dance Orchestra
- 4088 { LONE STAR (Intro.: "Just Say the Word")—Fox-trot,  
10-in. Rudy Wiedoeft's Palace Trio  
\$1.00
- 4089 { DESERT DREAMS—Fox-trot.....Selvin's Novelty Orchestra
- 4090 { AFGHANISTAN—Fox-trot .....Selvin's Novelty Orchestra  
10-in. BUDDHA (My Own)—Fox-trot.....Van Eps Quartette  
\$1.00
- 4091 { WAITING UNDER WESTERN SKIES—Waltz,  
10-in. Green Brothers Xylophone Orchestra  
\$1.00
- 4092 { SOMEBODY—Novelty One-step.....Rega Dance Orchestra

**Dealers' Service** { Every Okeh Dealer should use our Window Display Service. It has tremendous sales value. The Eighth Bulletin Display is now ready. Order from your distributor. } **Dealers' Service**

## General Phonograph Corporation

OTTO HEINEMAN, *President*

Factories:  
NEWARK, N. J.  
ELYRIA, OHIO  
PUTNAM, CONN.  
SPRINGFIELD, MASS.  
KITCHENER, ONT.

25 West 45th Street  
New York City  
N. Y.

Branch Offices:  
CHICAGO, ILL.  
SAN FRANCISCO, CAL.  
TORONTO, CAN.

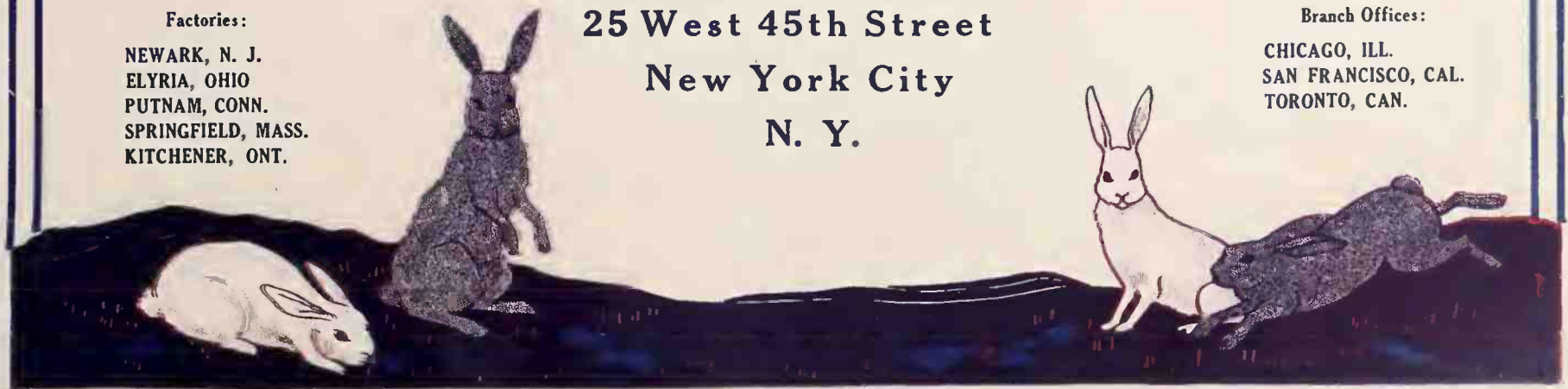







FOUR PROMINENT VICTOR MEN PROMOTED TO IMPORTANT POSTS IN THAT COMPANY



Ralph L. Freeman, Distribution

C. G. Child, Director

Walter J. Staats, Treasurer

Edward E. Shumaker, Director

LEADING INDUSTRY IN LEOMINSTER

Manufacture of Talking Machine Cabinets Fast Becoming One of the Most Important—Development Has Been Rapid in Last Few Years

LEOMINSTER, MASS., April 4.—A new industry which is fast becoming important in the industrial life of this city is the manufacture of talking machines. Steele & Monroe were the pioneers in this business, starting a few years ago in a small way in the old Lockey piano factory and later branching out into the factory of the Smith Piano Case Co., on Granite street.

The concern started first with the manufacture of small box-like machines, gradually developing to the more expensive machines which it now makes exclusively. At first only the cabinets for the talking machines were made, but as the firm developed the business the assembling of the complete machine was entrusted

to them and now this concern turns out nearly 100 machines a week, ready for the market. The motors are installed and tested at the factory and every machine is ready to play before it is shipped.

There is apparently an ever-increasing demand for the machines and the business promises to develop here to unexpected dimensions. Many who have been watching this industry for the past few years predict that the time is fast coming when it will be just as important as the piano industry.

The making and finishing of the cabinets are similar in many respects to piano making, and for this reason it is not difficult to secure trained workers in this city, which has long been a big piano manufacturing center.

Other woodworking concerns here are now considering taking over the manufacture of talking machines, and it is believed that more than one Leominster concern is now endeavor-

ing to arrange contracts for their manufacture.

The Ross Mfg. Co., one of the largest toy manufacturers of this city, has already undertaken the manufacture of talking machine cases in a limited degree and if the experiment proves successful it is likely that it will be added as one of the features of this concern.

INVALUABLE AS AN EDUCATOR

As a means of inculcating a love for music among the children, the talking machine is absolutely invaluable. Every family possessing a talking machine is insuring the musical education of the younger members of the family. As Thomas Whitney Surette says: "Music is the only form of beauty by means of which very young children can be educated, because it is the only form accessible to them." Children who early acquire musical appreciation find life more worth while in later years.

We Build PHONOGRAPHS to an Ideal—  
At a Price That Will Appeal!

We won't say we build the best as we do not deal in superlatives (there's too much competition in that line) but when it comes to Phonographs, well—we will leave it to your judgement as a connoisseur and business man.

"WE DO CLAIM SUPERIORITY  
WHEN IT COMES TO SERVICE"

Three big plants operating continuously give us an output that enables us to supply some of America's biggest jobbers promptly.

THREE LARGE



Plays  
All Records  
Correctly

Retailers—We have a jobber in your territory who can supply you over night with big value phonographs at a liberal discount.

6 Models—Retail Prices \$85 to \$200

FACTORIES

— ADDRESS —  
GENERAL SALES  
CORPORATION  
1520 Buffum St.  
MILWAUKEE, WIS.

OWNING AND OPERATING  
General Mfg. Corporation  
Recorderon Phonograph Co.  
Heaney-Schwab Billiard Mfg. Co.  
Makers of Billiard Tables Since 1882



# HIAWATHA



HIAWATHA, STYLE AA

THE Models we shall put out during 1920 will in no essential differ from the very successful Hiawathas of 1919. The 1920 line comprises five models. They are built and sold on the one basis of Quality; the basis on which Hiawatha prestige and commercial success have been founded.

## HIAWATHA PHONOGRAPH COMPANY

Offices 209 South State Street, CHICAGO



## THE MARKET FOR "TALKERS" AND RECORDS IN CHINA

While Records in the Chinese Language Are Preferred, There Is Quite a Market for American Popular Records—Dialects Should Be Watched—America's Unsold Records Not Wanted

WASHINGTON, D. C., April 3.—The market for talking machines and records in China is referred to most interestingly in a report sent the Department of Commerce by the United States Consul in Chungking. He makes a number of suggestions of exceeding importance to exporters of records which are well worthy of their consideration, as follows:

### Chinese Records Preferred

"A great deal of confusion has been caused by the failure of gramophone manufacturers to distribute Chinese records in a judicious manner. Having gramophone records in the Chinese language is an excellent plan and greatly increases their sale. Few Chinese enjoy and understand foreign music, and the Chinese records on this account are usually preferred. The records, however, are much more enjoyed if the language of the record is familiar locally.

"It is therefore necessary that special records be made for different parts of China. This is probably already known to many manufacturers, but many records intended for Canton and other cities in South China have been sent to Chungking, with unfortunate results. The Cantonese dialect is not understood in West China, the language here being much like Pekingese. Records prepared in the latter dialect, therefore, enjoy a wider sale in this district.

### Cantonese Records Returned to Manufacturer

"One firm in Chungking placed an order with an American manufacturer for Chinese records in the so-called Mandarin dialect, which is practically the same as Pekingese. He received, however, Cantonese records instead. He tried for many months to place them on the market, but was unsuccessful and was, therefore, obliged to return them to the manufacturer. A great deal of correspondence resulted and the local dealer was unable for a time even to get his money back or the records which he had previously ordered. As far as I know the case is still outstanding and the local dealer, who is a European, is likely to place his future orders with some other manufacturer.

### Popular Music Should Be Sent

"Many foreign dealers are not familiar with American popular songs and cannot, even with the aid of a catalog, order to advantage. They are sometimes obliged, therefore, to place a general order for a certain number of records without making any specifications as to tunes. Where this is done, the records should be selected with special care, for if they are easily sold more orders are sure to follow. In many cases, how-

ever, the home manufacturer exports old records which remained unsold because of their unpopularity in the United States. These records cannot be disposed of even in China, and while they remain in stock new orders are not placed.

"A large number of records are sold to foreigners in China, and their tastes are much like those of the people in the United States. To send out old records which do not sell at home is therefore a mistake. It is more profitable in the long run to send the very best class of records to the foreign market. It is not necessary that the records be of the most expensive kind,

## WIDELY KNOWN IN THE INDUSTRY

Harold Lamor, New Manager at Collings & Co., Newark, N. J., Popular and Capable

Harold Lamor, who, as referred to in last month's World, has recently joined the forces of Collings & Co., Victor distributors of Newark, N. J., as manager of that very important estab-



Harold Lamor

lishment, is one of the most popular men in the Victor business and has always been looked upon with favor and esteem by his former associates in the Victor Co.

It is interesting to note that Mr. Lamor made his first important business connection with the Victor Co. several years ago, and prior to his recent move he covered Michigan, Wisconsin, New York State, Pittsburgh and western Pennsylvania as representative of the traveling department of that company. Through his good work he has risen rapidly in the trade.

but popular airs should be selected for export whenever the selection is left to the discretion of the manufacturer."

The great commercial awakening that has taken place in China shows no sign of abating and American manufacturers are beginning to recognize that in China lie greater opportunities probably than anywhere else in the world. For the fiscal year ending June 30, 1914, the United States imported nearly \$40,000,000 and exported \$25,000,000 worth of merchandise; but in 1919 our imports and jumped to over \$145,000,000 and the exports to nearly \$110,000,000.

The Chinese, says the National Foreign Trade Council, look with great favor on American goods and would rather trade with us than with any other nation in the world. In view of this fact they should receive the best.

## BLESSED IS THE PATIENT SALESMAN

Store Life Page of Women's Wear Has Following Psalm for the Salesman

Blessed is the salesman who is patient, courteous and efficient, who rises when a customer enters and stands until the customer has been served, for he is a diamond in the rough, and will be cherished and sought out from all the others.

His "call trade" will make the boss sit up and take notice and his check book will outshine all those of his associates.

His bonus at the end of the year will swell his meager bank account so that the cashier at his bank will greet him with a smile and call him his friend.

Raises in his salary will come thick and fast and he will have things his own way all the days of his life.

Promotions will come to him regularly. Success will mark him. He will stand out among his fellow employes.

## HOW TO USE TUNGS-TONE STYLUS

Victor Co. Issues Careful Instructions for Victor Owners in April Supplements

In order to instruct Victor owners in the use of the Victor tungs-tone stylus the Victor Co. has issued a special booklet on this subject and has incorporated it in its April literature for dealers. The regular April supplement has for its cover design a picture of Geraldine Farrar as "Zaza" in the opera of that name. Appropriate selections for Easter are suggested. The usual list of foreign language supplements and the newspaper advertisements and review are included.



NYOIL is put up in the following sizes:

- No. 32 (Can) 1 Quart
- No. 128 " 1 Gallon
- No. 540 " 5 Gallon

# NYOIL

is the last word in the refining of high-grade oils, for every impurity is taken from it, leaving nothing but what is required to keep machines in perfect condition, being combined of four oils perfectly blended.

Will not Gum, Chill or become rancid; is free from acid. It is colorless and has no sickening smell, being absolutely odorless.

"The finest and most delicate pieces of mechanism do not prove efficient unless properly lubricated. Skill, Genius, Invention and Workmanship must have the proper Oil. Stop and consider this when you have to buy an Oil for household use."

Hundreds of satisfied customers have written us that they would never use anything else for Talking Machines, Graphophones, Phonographs and Sewing Machines

NYOIL will lubricate the machinery and polish all woodwork

and can be obtained of any "Up-to-date" Talking Machine Dealer in the world, and is manufactured by Wm. F. Nye, who for 50 years has made 80% of all the Watch, Clock and Chronometer Oil that is used in America.

WM. F. NYE, NEW BEDFORD, MASS., U. S. A.



NYOIL is put up in the following sizes:

- No. 1 Bottle 1 ounce
- No. 4 " 3 ounces
- No. 8 " 8 ounces







# Telling the Story of the Talking Machine to the Public by Means of Motion Pictures

In these days all classes of society have become devotees of the motion picture, and business interests, quick to appreciate this fact, have seized the opportunity to have films made telling the story of their industry and their product in a way that both appeals and carries the message convincingly. While many lines of business have made use of the motion picture the talking machine industry has not done as much as it should. To convey the message of music by means of the film and the shadow screen is one of the best ways possible to reach the public.

Manufacturers in their national advertising campaigns dwell on the advantages of their product and do much toward educating the general public about the talking machine industry. But the results could be greatly increased were the story told by means of the motion picture. Of course, in the past there has been the difficulty of getting these films into the theatres because of the fact that they were not in story form. But modern methods have found a way to produce films which not only tell the story of the merchandise and its manufacture, but tell it in a way that interests everyone. The industrial photoplay has its theme and interest just the same as the five-reel serial. The story part of the film is just as well done as the regular dramas and only the best actors and the most careful direction and staging are used. Nothing which smacks of the crude or the unfinished can stand before the critical public of to-day. It is economy to have the best and because these films are the best they can gain entrance to the best theatres and can travel in the same company as the feature film. Everyone who goes to the movie theatre has seen industrial films which gave him a new idea of this or that industry. Many a dealer in talking machines and other musical instruments has walked out of a movie theatre after seeing such a film and has longed to have one bearing on his own industry. He has seen visions of increased sales if he could only harness the power of the screen to advertise his goods.

Talking machine dealers might do well to consider what has been done in other lines and then they can judge for themselves what could be done in their own. Retailers in many cities have been able to reap the benefits of screen

advertising because their manufacturers had had short films prepared exploiting their respective brands. This was all right as far as it went, but these films were scarce and were available for the same dealer only at long intervals. Consequently there was no chance to put into operation the fundamental principle of advertising—repetition—so as to gain cumulative advertising value.

It was with the coming of the short playlet that the retail dealer was able to advertise his wares on the screen as regularly as he did in the local newspapers. These playlets were run

*To Convey Message of Music Through the Film Is One of the Best Ways to Reach the Public*

through the machine at the end of the regular films and their brightness and originality served to illustrate their message perfectly.

Why not have such films to illustrate the message which every talking machine dealer is trying or should try to convey in his advertising and back up the personal efforts of the manufacturer in his plea for music in the home? A brief consideration of the value of the visual against the printed argument can leave little room for doubt. Even manufacturers who pay thousands of dollars for a page in a national publication fill this page largely with an illustration, realizing that the picture tells their story as no words can do. In a motion picture theatre the mind of the patron is in a receptive mood. The theatregoer is at ease and has come to be entertained. If the advertising playlet affords this entertainment he remembers its message and also the name of the merchant who identifies himself with the film.

In addition to the value of these films in advertising to the general public they have another use of equal importance. It is in instructing employes in selling methods and in the history of the product that the screen can also play an important part. Here the playlets are not needed, but the longer films should be used. Details of the screen are retained in the mind much longer than would be similar details given orally. A lesson in salesmanship could be taught visually better than orally. It follows, also, that if the sales force in the talking machine department could see the story of the making of machines and records, the sources of the raw materials and the history of the machine or record from the time the material is in its primitive state to the day when the machine takes its place in the home, if they could see and know all this, they would be able more intelligently to guide the choice of their customers.

So both with the manufacturer and the retailer the film has its place. The great success with which other lines have used films should be an incentive to the talking machine industry to make use of one of the most vivid advertising mediums of the present day. The manufacturer can tell the story of the making of his product and the retailer can show clearly how his service department delivery system and other features operate to the public's interest and he can create the desire to buy by showing the results in the home following the possession of what he is trying to sell.

## PRICE INCREASE GOES INTO EFFECT

Unit Construction Co. Announces New Price Schedule on Equipment, Starting April 1

PHILADELPHIA, PA., April 6.—The Unit Construction Co. announces an increase in the prices of Unico equipment, effective April 1. This company reports that in spite of the magnitude of production and its exceptionally fine sales record, the great increase in the cost of labor and materials entering into Unico products has made necessary a raise in prices. The company reports, from present indications, that the demand for Unico booths, record racks and complete talking machine department equipment will this season exceed all former records.

*Schmelzer Arms Co.*

Kansas City, Missouri

Exclusively Wholesale  
Victrolas and Victor Records



## TALKING MACHINE AS FIRE ALARM

Clever Utilization of Machine in Ingenious Invention of Automatic Fire Alarm to the Credit of W. J. Luse, New York—How It Operates

The latest utilization of the talking machine as a factor for public good is illustrated in a patent for an automatic fire alarm, recently secured by Wm. J. Luse, of Engine Company 19, New York, who has had many years' experience with fires. His device is worthy of close consideration, and, in fact, already has been commended by a number of prominent publications

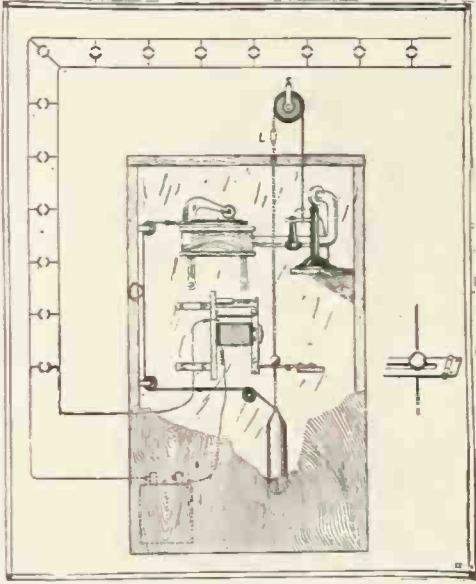

Fire Alarm Mechanically Operated and notable men, the Sunday World of March 21 giving a lengthy description and illustrations of this invention.

In conversation with The Talking Machine World Mr. Luse pointed out that the invention is in two forms, one mechanical and the other electric. The object of both is to telephone central that a fire has broken out in a particular building. The heat generated by the conflagration is made to do this automatically. So sensitive is the apparatus that Mr. Luse has set it

off by lighting a newspaper in his bathroom. The most important parts of it are a phonograph bearing a ten-inch disc with repeating attachment on which have been recorded words such as "Hello, Central! Notify Fire Headquarters, 1000 Rhinelander, that there is a fire at No. 312 West Twentieth street, fourth floor, rear, apartment ten," repeated as many times as the record will hold, and a telephone receiver so hung that the instant the phonograph starts it swings into position, rings "Central" and catches the words as if a human mouth had spoken them.

This operation which seems complex, nevertheless simple, is performed in the mechanical type by the mere dropping of a weight. The weight is hung from a chain or cable in which are several links made of one of the metal amalgams that melt at a comparatively low temperature—that used by Mr. Luse melts when the temperature is raised suddenly to 112 degrees F. When a link melts, the cable is broken and the weight drops, releasing a brake upon the phonograph and raising the receiver of the telephone. That is all, and it is very simple.

The electric device is only slightly more complex. In this common battery wire is strung along the ceilings of as many rooms as desired, and on the wire are thermostats at intervals of about twenty-five feet, or one to a room. When one of these thermostats closes, as it does with an increase in heat, an electric circuit is closed, exciting an electric magnet. This draws over a commutator arm which supports the free end of a hinge. The dropping of this hinge releases a slot which supports a small ball, this again supporting the weight. The fall of the weight sets the phonograph in motion and lifts the telephone receiver as before.

One or two dry batteries of from one and one-half to three volts are sufficient for this. Then, when the heat gets much more intense, that is, when the fire is thoroughly under way, another fuse burns out, cutting the weight off from the arm of the telephone receiver, which drops back in its neutral position.

To put the apparatus into service, all one has to do is to place the telephone on its shelf beside the phonograph, hook the cable to the receiver arm and forget it. A gradual rise in heat, such as might take place in hot weather in a house closed for the Summer, does not cause the fuses to melt, this taking place only when the heat comes suddenly.

Among the advantages claimed for this invention are its economy and simplicity. In country

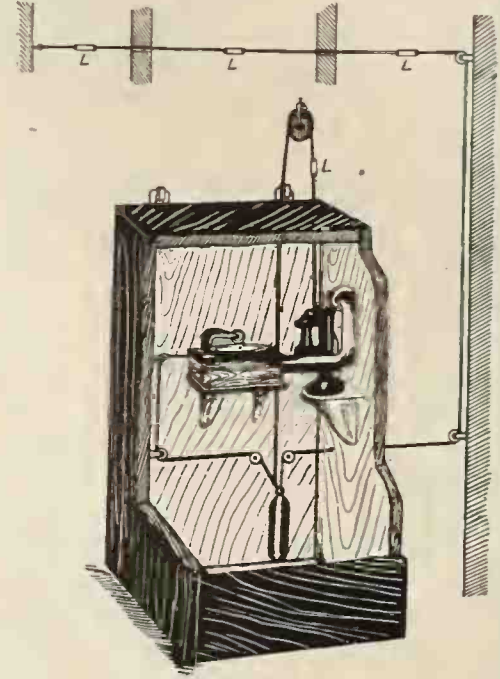

Electric Automatic Alarm

homes and isolated country factories, particularly, it is almost invaluable, as there is invariably delay in transmitting fire messages by ordinary means. It is also invaluable in high loft buildings where a fire cannot be seen from the street, with possibilities of delay in sending in alarms and damage from the sprinkling system. In fact there are a great many uses to which the new automatic fire alarm applies most effectively.

# Roly Boly Eyes in Bedford, Pa.

FOLKS in Bedford have found out that Emerson Standard 10-inch Gold Seal Records furnish the right kind of inspiration for dancing.

And no wonder! Look at the musical combinations now playing exclusively for Emerson Records.

Continental Military Band  
Emerson Military Band  
Plantation Jazz Orchestra

Sanford's Famous Orchestra  
Emerson Xylo-Phiends  
Emerson Dance Orchestra



**Emerson Sales Company**

4018 JENKINS ARCADE BUILDING  
PITTSBURGH, PA.

It's the same everywhere. Emerson dance hits have a way of getting dancers on the floor—and keeping them there.

A good way to pass up some nice easy money is to refrain from handling Emerson Records. But why refrain? Write us for facts.



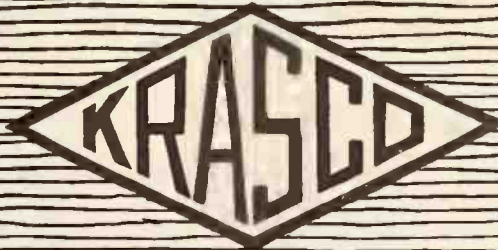

# The Phonograph Salesman

## SAYS:

“Talking Machines are sold through confidence. When selling a Phonograph equipped with a KRASCO Motor you have confidence in its absolutely dependable and artistic performance. The prospective purchaser may not know that the Motor is the very heart of a Phonograph, but you do, and it’s the salesman’s confidence in the KRASCO that makes the sale easy.”

And *again* he’s right.

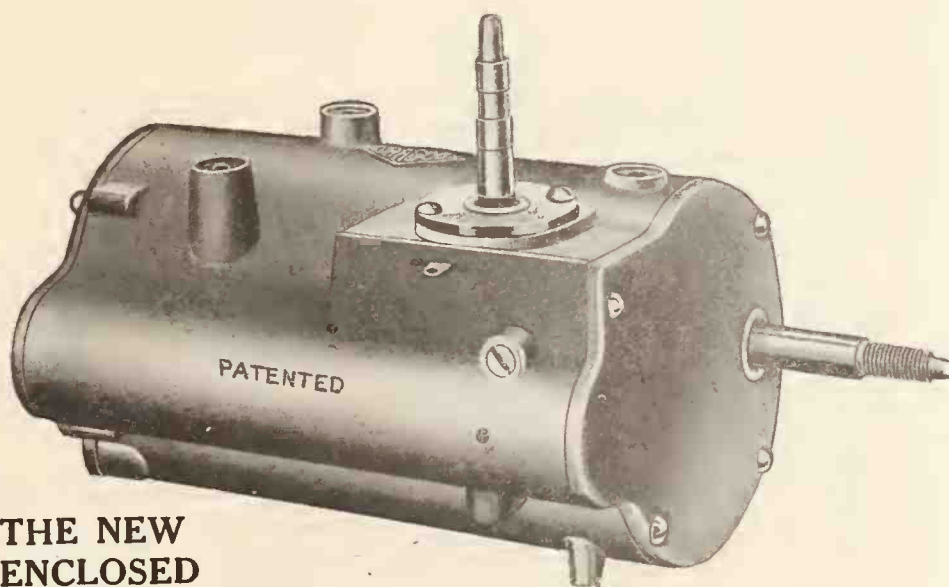

Send for Literature on KRASCO Open and Enclosed Motors, Sterling Reproducers and Tone Arms.

THE NEW ENCLOSED KRASCO MOTOR— THE SENSATION OF THE NEW YORK SHOW

Krasberg Engineering & Manufacturing Corporation

536 Lake Shore Drive

Chicago Illinois U.S.A.

# Krasberg



# How the Record Album Has Become an Effective Vehicle for Record Sales :: By Phil Ravis President, Peerless Album Co.

At this particular time when there is so much speculation as to the possible extension and future of the talking machine business it seems pertinent to say a word about record albums, which have played so important a part in the development of the industry, and to point out certain outstanding features of interest in their relation to record sales as revealed in a recent careful analysis of the subject.

As the dealer is always of prime consideration in the mind of the manufacturer his position was taken up first and considered from every angle where the future and stability of talking machine progress were involved. What the album means to the life and permanency of the individual dealer's trade was the subject of our

first investigation. We visited perhaps a hundred city dealers and half as many country dealers, interrogated them on phases of record merchandising as affected by the introduction of albums, and compiled this consensus of opinions on album questions, as follows:

1. The album as a safe, compact and convenient means of classifying and keeping records is distinctly in public favor.
2. The cabinet type machine equipped with albums, except in rare cases where the element of extra expense solely is considered by the prospect, is easier and more satisfactory to sell.
3. Albums do sell records. The empty album in the home is a constant reminder to the owner to fill it with records.

4. The classification habit of owners, whereby they devote one album to each distinct class of music, is developing record business along sound and permanent lines.

Our investigation was next concentrated on the standard talking machine lines and a comparison of the styles that provided storage space for records. Working on thirty-five complete lines (exclusive of period models) a digest was made as follows

Average number of cabinet types:

In each line.....	6
With albums .....	3
With album shelves.....	2
With other interiors.....	1

Average record capacity of types:

In each line.....	66
With albums .....	72
With album shelves.....	68
With other interiors.....	60

This tabular review of current talking machine models shows first of all that types with albums or shelves for albums are in the majority; second, that the record-filing capacity of the album types is greater than that of those with other interiors, allowing dealers a far more extensive scope for record sales.

### The Album and the Cabinet Phonograph

It would be a rash assumption to say that the record album has been wholly accountable for the popularity of the cabinet type phonograph. The greatest single achievement of the industry, namely, the successful combination of a piece of ornamental furniture with the "universal instrument of music," is certainly deserving of recognition on its own merits. Yet, in looking back over the past few years of evolution, it is a toss-up whether the cabinet type made the albums or the albums made the all-in-one machine. At any rate, they were introduced at about the same time and have developed, grown together and become so intimately associated as to be thought of as one and inseparable to-day.

It is a matter of history that the manufacturers who conceived, introduced and promoted the first cabinet types looked immediately with favor upon the album, giving up the cloth covered box interior and installing albums just as soon as the success of the cabinet machine was assured. It should be a fact of potential significance to the trade in general that these manufacturers are using albums to-day even in their highest priced models.

### Dealers' Interests Considered

Incidentally, those first in the field with the cabinet types were also makers of records and therefore felt a responsibility and obligation to the dealer to afford him means of quickly and profitably moving record stocks. Primarily,  
(Continued on page 27)

# FAULTLESS PIVOT BEARING CASTERS

Casters that roll easily across the floor—and smoothly. No chatter—no unsteadiness.

Simple construction—no complicated parts to get out of order, nothing to retard easy movement. Strong—plenty of metal in required places to resist strains.

Silent—neat appearing—a real necessity to YOUR talking machine, these FAULTLESS CASTERS.



Full Size—C-65

Made with leather, fibre, felt, steel and lignum vitae wheels. A word from you puts all our caster experience at your service and brings you a copy of Faultless Catalog "G".

**FAULTLESS  
CASTER COMPANY**  
EVANSVILLE, INDIANA

"Move the FAULTLESS Way"

Eastern Sales Office:  
Geo. Mittleman, 487 Broadway, N. Y.

## ROTTEN STONE

We are the only miners and manufacturers in this country of Rotten Stone for use in Phonograph Record making. Our product is now in use by practically every record manufacturer in this country. We are also headquarters for all other minerals for record making and everything we handle is made especially for this purpose and absolutely guaranteed. Expert advice given upon any formula.

**KEYSTONE MINERALS CO.**  
41 Union Square, New York City





# Blue Bird Talking Machine Company

Los Angeles, U.S.A.

—Territory open to dealers and jobbers

## Sells on Sight

IT is the favorite of dealers on the Pacific Coast.

There is instant demand wherever it is shown to the public—justified by its unusual merits.

Its distinctiveness is marked by its beautiful cabinet—its graceful lines—its high finish. The panels are full three-quarters—equipment the best.

—but the real reason of its popularity lies in its most remarkable tone, due to an unseen device that produces

## “The Tone That Thrills”

The BLUE BIRD will be the favorite in your city and prove as profitable to you as it has to the dealers along the “Golden Shore.”

Write today for a descriptive folder with discount sheet.

*The Blue Bird Plays All Makes of Records and Plays Them Better Than Any Other Phonograph*

BLUE BIRD TALKING MACHINE CO.  
Manufacturers  
Los Angeles, California

A. VAILLANCOURT









Oscar Seagle's "Golden Crown" and "Standin' in de Need o' Prayer" are real, honest-to-goodness negro revival hymns. They're going big. Order that way. A-2889.

Columbia Graphophone Co.  
NEW YORK



## RECORD ALBUM A TRADE DEVELOPER

(Continued from page 26)

these manufacturers saw the immediate advantage to the dealer in producing, along with the machine, a convenient storage space for large quantities of records. They also sensed the less apparent record sales possibilities of the album, which was radically sound in the principle of encouraging record buying. Opposed to the rack or other interior the album was superior; it was something to be taken from the machine and laid around the house—something to be seen, empty or full. As an ever-ready reminder to the owner to purchase more records the album put a profitable dealer selling element in each cabinet type so equipped. It was, therefore, with the fullest conviction on the part of the dealer that albums do sell records that so many cabinet types with albums came upon the market.

### Dealer Demand Satisfied

Dealer demand more than public opinion is a prevailing influence on manufacturers' policy. What the dealer wants he usually gets in spite of the fact that an article without merit will burden his sales floor. In the case of albums they have met with public approval and from the first added impetus to the dealers' preferential leaning toward cabinet types equipped with albums.

The record album, beyond the shadow of a doubt, has been thoroughly established as an indispensable accessory of the business. It is a manufacturer's sales argument to the dealer, a dealer sales stimulant and first, last and always a welcome and lasting convenience to the talking machine owner, the ultimate consumer.

### Non-record Manufacturers' Policy

Nor have those talking machine manufacturers who have no commercial interest in the sale of records totally ignored the necessity of "record seating" capacity in the form of albums. They, too, have gripped the sales angle that albums apply to cabinet types and have accord-

ingly adjusted their product to the requirements of the market.

Among these types it is interesting to note that more than 78 per cent contain either albums or shelves for albums. Linked right into this policy also is definite realization that the thousands of records now being merchandised by dealers must be accommodated and that the buying public is interested no more in the phonograph for its musical value than it is in its capacity for containing a large assortment of records.

Just so long as the dealer knows that by placing an empty album in the hands of one of his good customers he is exposing himself to the additional sale of twelve good records, every manufacturer will find it policy to associate albums with his product in one way or another.

### A Dealer Sales Plan

Following the classification idea suggested in another paragraph of this article it is interesting to note that several of our dealers have worked this up into an elaborate sales plan and actually increased their record sales substantially as a result. No doubt other dealers could use it to advantage. The separate steps to be followed are:

A. Arrange with the album manufacturer or procure locally a supply of neatly printed gummed labels, just the width of an album, bearing titles such as "Dance," "Opera," "Humorous," etc.

B. Place these on a dozen or so albums and place them on a table in the center of your sales floor.

C. Have a neatly worded card alongside which will read to this effect: "An exceptional album at actual manufacturing cost. To all who wish to start a classified record selection and whose purchases consist of three or more records of any distinctive class, one of these albums will be sold at actual cost of . . . ."

D. Dress your window accordingly and have a duplicate card made for the trim, displaying it with albums the same as inside the store.

The results of the plan will be these: First, you will sell three records of a standard class to those who wish to procure an album at cost. These records, because they belong to a standard class, will come out of your old stock and not put any pressure on scarce new hits. Second, you will be putting the "album temptation" before your best customers, encouraging them to buy whole sets of records covering extensive classes of music.

### New Uses of Albums

Albums, constantly before the patrons of your store, will keep the classification idea moving and carry with it many records that have long laid dormant on your shelves. One of our big dealers in the Middle West recently gave us some new uses of the albums that seem worthy of mention. As a record carrying case let the instalment collector take an album with him on each call and play over one or two records for the new phonograph owner; he usually leaves them and brings in the cash. As a silent salesman, an album, full of records on a table in the booth, labeled, "Our Best Selections," will attract customers' attention and make many "self-service" sales while the clerk is busy in other parts of the store.

A résumé of the album proposition as it affects the future of the phonograph industry may be made in the following terse sentence "Albums sell records."

### A TEXAS INCORPORATION

A charter has been granted to the Trussell-Jackson Phonograph Co., Dallas, Tex., with a capital of \$10,000. The incorporators are G. M. Jackson, E. E. Trussell and E. T. Martin.

### DRUGGISTS ADD COLUMBIA LINE

In order to handle a full line of Columbia Grafonolas and records Golden & Perry, of Georgetown, Ky., are planning to alter their present drug store.



## BEAUTY and TONE Combined

The VICSONIA is the recognized reproducer for playing Edison disc records on Victor and Columbia Machines.

NO LOOSE PARTS JUST SLIPS ON A CHILD CAN DO IT

## "VICSONIA" REPRODUCER (Model "A")

### ANOTHER SUCCESS!

MODEL "B" VICSONIA—Plays both Pathe and Edison disc records.—Order sample NOW. Retail Price \$7.50

A sample reproducer Model "A" or "B" will be sent on receipt of \$4.50

VICSONIA MFG., CO., Inc., 313 E. 134th St., New York, N. Y.



Edison Message No. 68

The new edition of "Edison and Music," which is coming off the press at this time, contains the following:

Careful calculations of the various cost elements (diamonds, genuine mahogany, quarter-sawed white oak, walnut, special steel and bronze, skilled labor, etc., etc.) involved in the manufacture of the New Edison, indicate that the prices noted in this book reflect only 50% of the increases in manufacturing cost that have occurred during the past eighteen months. In other words, it has been our policy to absorb and write off, as a loss, 50% of the increased cost of manufacture. However, conditions are such that we are obliged to reserve the right to advance our prices at any time, without notice, and all orders are subject to the prices effective when executed, irrespective of the date of receipt.

THOMAS A. EDISON, INC.

February 16, 1920.  
Orange, N. J.

We have, in fact, absorbed **more** than 50% of the increased cost of manufacture and the selling prices of Edison Phonographs (including War Tax) have been increased less than 15% since 1914. This Company has foregone enormous profits, which it might have taken.

It may be necessary for us to increase our prices during the present year, but we shall avoid this action as long as possible, and, if it does become necessary to make increases, they will be carefully calculated, with a view to making them permanent prices. In other words, we are willing to sacrifice immediate profits, to stabilize the Edison Phonograph business.

---

**THOMAS A. EDISON, Inc.**

ORANGE, N. J.



**WILL BE POPULAR WITH FARMERS**

**Erstwhile Jersey Politician Discovers Secret of the Barnyard and Makes Some Cackling Records—Hopes to Equip Every Henhouse in the Country With a Talking Machine**

Every henhouse in the United States will soon carry a talking machine and a set of records as a part of its regular equipment if the plans expressed by Frank McDermott, late candidate for Governor of New Jersey, live up to the inventor's expectations. Farmers have written him many letters inquiring for particulars outlining the advantages of a poultry yard musically directed. During the decidedly unpleasant weather this winter Mr. McDermott decided that he was thoroughly tired of cold storage eggs and longed for the kind fresh from the nest. Breakfast eggs are proving such uncertain factors these days that anything which will enable a hard working man to approach this morning ceremony with greater courage and a smile is welcome. Mr. McDermott figured that if he could bring it about that the hens could be made to produce to capacity he would be doing humanity a great service.

So he investigated and found that when a hen cackles this sound has marvelous effects. It induces other hens to proceed to their nests and do their patriotic duty. It follows that the more hens you have cackling in your barnyard, the more eggs you will have. In these days of trouble with organized labor it might happen that all the hens would elect to cackle in the yard rather than remain on their nests. And then the plan would fail dismally. But

Mr. McDermott has foreseen every possibility. He will have his talking machine produce alternate sounds like the cackling of hens and the crowing of roosters. An automatic device relieves him of the minor details and causes the machine to operate each morning. In this way there is no loss of efficiency, for all the hens can devote their time to their eggs and need not be detailed for cackling in the yard. It is said that records have been made and are now being tried out. Without doubt we can look for some startling fall in the price of our favorite breakfast food!

**REPEATERSTOP CO. IN NEW YORK**

Open Office at 1170 Broadway, With Robert Mautner as Manager

The Repeaterstop Co., of Chicago, Ill., manufacturer of the Repeaterstop, has opened a New York office at 1170 Broadway, with Robert Mautner as manager. He will travel Eastern territory in addition to covering New York City, and according to present plans the export business of the company will also be handled through the New York office.

**A NEW YORK INCORPORATION**

The Nightingale Phonograph Co., Manhattan, has been incorporated with a capital of \$10,000. The incorporators are M. Amster, A. S. Lester and J. Staal, 157 West 123d street, New York.

Glynn Cremer and W. Koehler will soon open an Edison store in Red Wing, Minn. Later on it is hoped to add other musical lines.

**NEW BUFFALO CORPORATION**

**Walters & Barry Corp. Takes Over Jobbing Business of Belmont Walters & Co. and Will Handle the Brooks and Starr Phonographs**

BUFFALO, N. Y., April 5.—There was recently incorporated under the laws of New York State the Walters & Barry Corp., which was formed to take over the talking machine jobbing business of Belmont Walters & Co. This move was found imperative in view of the tremendous demand in this territory for the Brooks automatic repeating phonograph. The new corporation is the distributor for the Brooks phonograph in this territory, and in addition has acquired a franchise for Starr phonographs and Gennett records, which have won a large measure of favor.

The officers of the corporation are Belmont Walters, president, formerly president of the Belmont Walters & Co.; Wilbur E. Houpt, vice-president, well-known attorney and counsel for the Buffalo Terminal Station Commission, and Edward H. Barry, secretary and treasurer, formerly assistant superintendent of the Buffalo Weaving & Belting Co. The salesrooms, offices and warerooms of the company are located at 256 Main street, in the Associated Service Building.

The Walters & Barry Corp. is now making arrangements for an intensive campaign in behalf of the Brooks automatic repeating phonograph. This instrument has attained much success in this territory and its distinctive features, particularly the Brooks automatic repeater, have won the commendation of the trade and the public.

**The Motrola**

will be backed up with a big National Advertising Campaign during 1920

Ask your jobber to tell you all about the *big profits* other dealers are receiving through the sale of the Motrola, or drop us a line direct and give the name of your jobber.

**JONES-MOTROLA, Inc.**

29 West 35th Street  
New York City





# Successfully Developing a Sales Force by Reaching Their Hearts :: :: By Frank K. Pennington

From Interview in *Printers' Ink*

There appeared in a recent issue of *Printers' Ink* a very interesting interview with Frank K. Pennington, assistant general sales manager of the Columbia Graphophone Co.—a gentleman who has been identified with some of the greatest sales organizations in the country, and whose intimate familiarity with every phase of merchandising and salesmanship has won for him an enviable position in the sales world. Some of the many valuable nuggets in this interview are extracted and presented herewith:

Mr. Pennington confesses privately that the use of the word "efficiency" more than nine times in one conversation wearies him, and that if anything goes wrong he subjects himself to a thorough inspection first before turning the magnifying glass on his men. This is enough to indicate that Mr. Pennington doesn't follow any rules but makes them up as he goes along.

No two cases are ever alike to me, he says. Men don't come in standardized patterns. You can't deal with them as if they were a garage full of motor cars all made by the same manufacturer. Human nature is too varied and too full of unsuspected knobs and corners to permit its being gauged always by the same measure.

A man is more than a machine. But suppose, for a moment, that we compare him to one. If you own an automobile and you find that the engine is knocking or that friction is causing a loss of power, you don't punish the car. You don't fine it, or lay it off for a week and expect to find it running as good as ever. You find out what the trouble is and remedy it.

But a man is more than a piece of mechanism. He is different from a machine in that he has a heart. I am not primarily interested in a man's

body, not even in his mind. What I want to reach is his heart.

Loyalty, faithfulness, devotion and steady ser-



Frank K. Pennington

vice do not emanate from a man's legs or his head. They come from his heart. When you have that, you have all the rest of him. I look upon human nature as fundamentally good. It

will always work out in the right direction if it is given a decent chance to operate.

We can afford to be at least as merciful as a surgeon. When a doctor discovers that a patient's physical properties are not functioning normally, he does not cut off the patient's head or lose his temper with him. He studies the case until he learns what is the matter and then he does those things which will allow the sound bodily forces to reassert themselves. I try to follow that plan in dealing with men. If I find a salesman is not working up to standard I do not attempt to pass judgment on him until I learn what is interfering with his usual good performance.

You always take risks in trying to discipline a man. For discipline is not something that can be imposed on him from without; it must proceed from inside the man.

When I was a boy I was employed in a small printing establishment. It was my function to kick the job press. One day I put a small job on the press and started off. But I had neglected to adjust the paper fingers properly, with the result that when the jaws of the press closed, the metal fingers were jammed into the form, ruining the face of some of the type.

The owner of the establishment came at me like a whirlwind. He bawled me out in the presence of the whole force. He couldn't have made me feel worse if I had committed murder. The result was that instead of ruining a little type, I wished that I had smashed the whole press and made the ruin complete. I was never a satisfactory employe after that. I was too full of resentment to do good work. I have never

(Continued on page 32)

## Fast Shipping Service

## Okeh Records

We have been able to give our dealers exceptionally good service in the shipment of Okeh Records. Our deliveries total 85% of orders and this should mean much to you in ordering these fast-selling records.

**Order New Okeh Special Release Records Now**

4079 { I'LL SEE YOU IN C-U-B-A (Tenor) with Rega Orchestra  
Billy Murray  
DARDANELLA (Tenor) with Rega Orchestra Billy Murray

4080 { MY ISLE OF GOLDEN DREAMS (Waltz)  
Joe Thomas' Sax-o-tette  
IN AND OUT (One-Step). Joe Thomas' Sax-o-tette

**Stoffer & Stackhouse Co., Inc., Bourbon, Ind.**



THE ORIGINAL  
**THE WINDSOR PHONOGRAPH**  
 THE ARISTOCRAT.

**They All  
 Follow the Leader**

Have you noticed how many makers who formerly considered themselves leaders in the phonograph industry are now following the leadership of the Windsor Console Phonograph?

The success of the Windsor Console Phonograph seems to have inspired these makers to accord the Windsor the most sincere form of flattery.

When we decided to make phonographs we did not try to copy or imitate the cabinets of some other maker, but we originated a cabinet of our own, the Windsor Console Phonograph, patented November 9, 1915, and September 24, 1918.

The acknowledged leader of all phonographs, "The Windsor," is sold direct from the factory to the dealer, no jobber's profit to pay.

We invite progressive dealers to consider the Windsor when making their plans for the coming year.

An attractive catalogue on request to dealers only.

**THE WINDSOR FURNITURE COMPANY,**  
 1420. CARROLL AVE. CHICAGO, ILL.:  
 :ESTABLISHED 1885:

LIST OF THE WINDSOR PHONOGRAPH CABINET PATENTS  
 48122 • 49655 • 50479 • 1279743 • 50480 • 50481 • 50483 •  
 49654 • 50478 • 50482 • 50484 •

*F. A. Meyersheim*





## DEVELOPMENT OF A SALES FORCE

(Continued from page 30)

forgotten that episode in dealing with other men. Whatever the circumstances, I guard myself against wounding their pride and destroying their self-respect.

I have learned that the old beliefs are best. There is no better guide than the Golden Rule, which when applied, simplifies all human relations. I not only try to observe it myself but I try to teach my men to observe it in their relations with each other. I do not emphasize its sanctimonious aspect, but point out its practicability and common sense.

I said a while ago that I seldom deal with two cases in the same way. But that does not mean that there are not certain principles that govern every action. I try to decide what the principles behind each case are, and then I use that as my guide. When you work with principle you become invincible. Policies may be temporary but principles are eternal. I like to sum it up this way: Principles always work; policies may not.

After all, getting men to work for you, or rather, with you, is a matter of using common sense, together with an understanding of human nature. You have as much human nature as anybody else. Therefore, when you have a decision to make, I always say, "Try it on the dog." That is, try it on yourself first. Put yourself in the other fellow's place. You'll find the results are always good.

I've been dealing with men for a good many years, but I have never yet deliberately fired a man. I've never found it necessary to do so. If a man has sufficient opportunity and has not made good, I simply call him in and tell him the facts. I point to his record and let him see for himself how much he has fallen short. It seldom takes such a man long to arrive at the necessary decision by himself.

I do not like the expression "handling salesmen." I object to handling men. I try to get along with them. To get along with them you must trust them, and they must trust you. You will get from them what you are looking for. Expect 100 per cent delivery from them and you will get 100 per cent performance. I have

sometimes tried this principle at theatre box offices, where mutual trust between seller and buyer does not always prevail. When I find myself in a strange town, and have an evening to spare, I go to a theatre and say to the box-office man:

"I'm a stranger here and I don't know your theatre or the location of your best seats. But I would like a good seat on an aisle if possible, and in a part of the house where I can enjoy the performance."

Other people have told me sad tales about box-office men, but in every case where I have put it up to the ticket seller, I have invariably gotten first class seats, or else he frankly told me that he didn't have what I wanted.

If I find that a man for some reason is mentally or physically unable to deliver the goods, I tell him to go home or to go on off and play. I tell him to blow himself to a trip or get a change of atmosphere. I leave it to him to decide when he is feeling fit again. A man is a battery, and sometimes he needs recharging.

Mr. Pennington's methods sound almost ridiculously simple. They consist in following the easiest way. Yet, after viewing the results obtained, who shall say that they are not effective?

### The New Model "E"

# Garford Phonograph

*The Greatest Value on the Market*

IMMEDIATE DELIVERIES IN ANY QUANTITY

High  
in  
Quality  
Low  
in  
Price



High  
in  
Quality  
Low  
in  
Price

*New Model "E" Garford Phonograph*

The New Model "E" Garford Phonograph has every desirable feature of the high price phonograph

- 1 Plays all makes of records without an attachment.
- 2 Superior Tone Quality.
- 3 Standard Motor of Recognized Merit.
- 4 Artistic Appearance.
- 5 Guaranteed to Give Excellent Service.

*Order Now for Immediate Delivery*

SELLS LIKE "WILD-FIRE" THE YEAR ROUND

*We have an Attractive Dealer Proposition*

## The General Phonograph Mfg. Co.

(FORMERLY NAMED THE GARFORD MFG. CO.)

ELYRIA, OHIO

### TO BUILD NEW STORE IN BROOKLYN

Baim Bros. & Friedberg, Inc., Brooklyn, N. Y., Victor, Columbia and Sonora dealers, are erecting a new building just across the street from the branch store at Utica avenue and St. John's Place. The rapid growth of the talking machine business in that section of the city made larger quarters imperative. Irving Feinson has been engaged as manager of the new store. Baim Bros. & Friedberg, Inc., operate three stores in Brooklyn at 1525 and 1658 Pitkin avenue and 235 Utica avenue. In all three stores are carried the Victor, Columbia and Sonora products.

### INCREASE BOOTH EQUIPMENT

Four booths, sound-proof and finished in gray, for demonstration of Victor records have been added to the music department of the Gintz Co.'s store at New Philadelphia, O., one of New Philadelphia's most modern music stores.

F. E. Tompkins, of Rice Lake, Wis., is establishing a new talking machine and piano store at Barron, Wis.

### "The Music Without the Blur!"

This ideal of talking machine manufacture is attained more nearly than by any other, in the construction of the

### MARVELOUS MAGNOLA

*"Built by Tone Specialists"*

"Magnola's Tone Deflector eliminates the scratch"

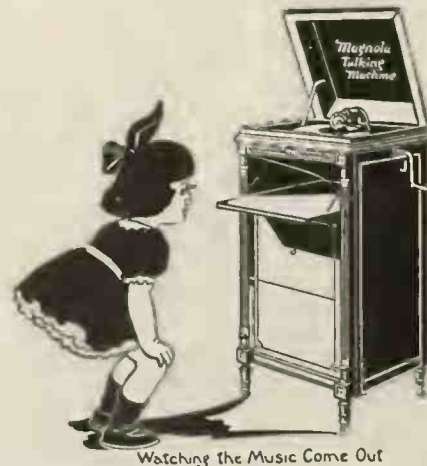

Watching the Music Come Out

We want to show you how to make money with MAGNOLA; and how MAGNOLA is the best buy on the Talking Machine Market to-day.

Send us your name and let us send you some real Talker Tips.

### MAGNOLA TALKING MACHINE COMPANY

OTTO SCHULZ, President

General Office  
711 MILWAUKEE AVENUE  
CHICAGO

Southern Wholesale Branch  
1530 CANDLER BLDG.  
ATLANTA, GA.



# ANNOUNCING NEW CHARMAPHONE MODEL

"THE UNIVERSAL PHONOGRAPH"

*A machine with many sales features. Make  
it your leader and cash in the profits*

Height  
42 inches

Width  
18 inches

Depth  
23 inches



High Grade  
Mahogany  
Finish  
Workmanship  
and  
Construction  
the Best



Equipped  
with Famous  
Smooth  
Running  
and Noiseless  
Heineman  
No. 36 Double  
Spring Motor



New  
Charmaphone  
Tone Arm  
and  
Reproducer

CHARMAPHONE MODEL No. 4—RETAIL PRICE \$75.00

*Write For Our New Catalog Illustrating Our 1920 Line*

## CHARMAPHONE

39 West 32nd Street, New York City

## COMPANY

Factory: Pulaski, N. Y.





Al Jolson not only sings but whistles "Swanee," his latest *Sinbad* hit. You'll whistle, too, when you count your receipts. A-2884.

Columbia Graphophone Co.  
NEW YORK

### STOCKHOLDERS HOLD MEETING

General Phonograph Corp. Stockholders and Directors Meet—Otto Heineman Re-elected President—W. G. Pilgrim Becomes Treasurer

The annual meeting of the stockholders of the General Phonograph Corp. was held recently

W. G. Pilgrim, Jacob Schechter, Jos. W. Harriman, A. W. Fritzsche and G. P. Rowell.

At the meeting of the board of directors, held the same day, the following officers were elected for the coming year: President and general manager, Otto Heineman; vice-presidents, W. A. Nieracher, Adolph Heineman, A. G. Bean, A. F. Meisselbach and Bernard Benson; treas-

as a director and the election of Mr. Pilgrim as treasurer of the corporation. Mr. Benson is an executive of Merrill, Lynch & Co., and was elected a director in place of Mr. Merrill.

The announcement of Mr. Pilgrim's election as treasurer of the General Phonograph Corp. will be welcome news to the talking machine trade everywhere, as Mr. Pilgrim has a host of friends in the industry who appreciate and recognize his remarkable executive acumen and thorough knowledge of the business.

The financial report submitted to the stockholders indicated that the General Phonograph Corp. had closed in 1919 the best year in its very successful history, the figures showing a very substantial increase over 1918, the previous high-water year. The outlook for 1920 is very gratifying, and the sales totals for January and February were far in advance of the figures for the corresponding months of last year.

### EDWARD H. DROOP HONORED

WASHINGTON, D. C., March 23.—Edward H. Droop, of E. F. Droop & Sons Co., Victor distributors, is a member of the Advertising Club of this city, and has been appointed to serve as a member of the special committee on clean advertising. Mr. Droop is much interested in the civic affairs of the nation's capital and has given much of his valuable time to their betterment. The recognition of the value of his services is to be found in his appointment by the president of the Washington Board of Trade as national councilor and delegate in full to the eighth annual meeting of the Chamber of Commerce of the United States, to be held in Atlantic City during April of this year.



Otto Heineman

at the office of the company, 25 West Forty-fifth street, New York. At this meeting the following directors were elected: Otto Heineman, W. A. Nieracher, Adolf Heineman, A. G. Bean, A. F. Meisselbach, Bernard Benson,



W. G. Pilgrim

urer and assistant general manager, W. G. Pilgrim; secretary, Jacob Schechter.

There are no changes in the personnel of the directorate and officers for the coming year with the exception of the election of Mr. Benson

From "The Total Eclipse"  
for February

*Eclipse Certainly Leads In Personal Service Everytime*

THE ECLIPSE MUSICAL CO.  
Cleveland, Ohio,  
VICTOR  
WHOLESALE





# The Heineman Motor



*Gives Universal Satisfaction*

The unvarying quality and mechanical precision of the Heineman No. 77 Motor have been recognized by the phonograph manufacturing trade of the world.

More than 1,000,000 of these motors have been sold.

The sales value of your phonographs will be enhanced by the use of this motor.

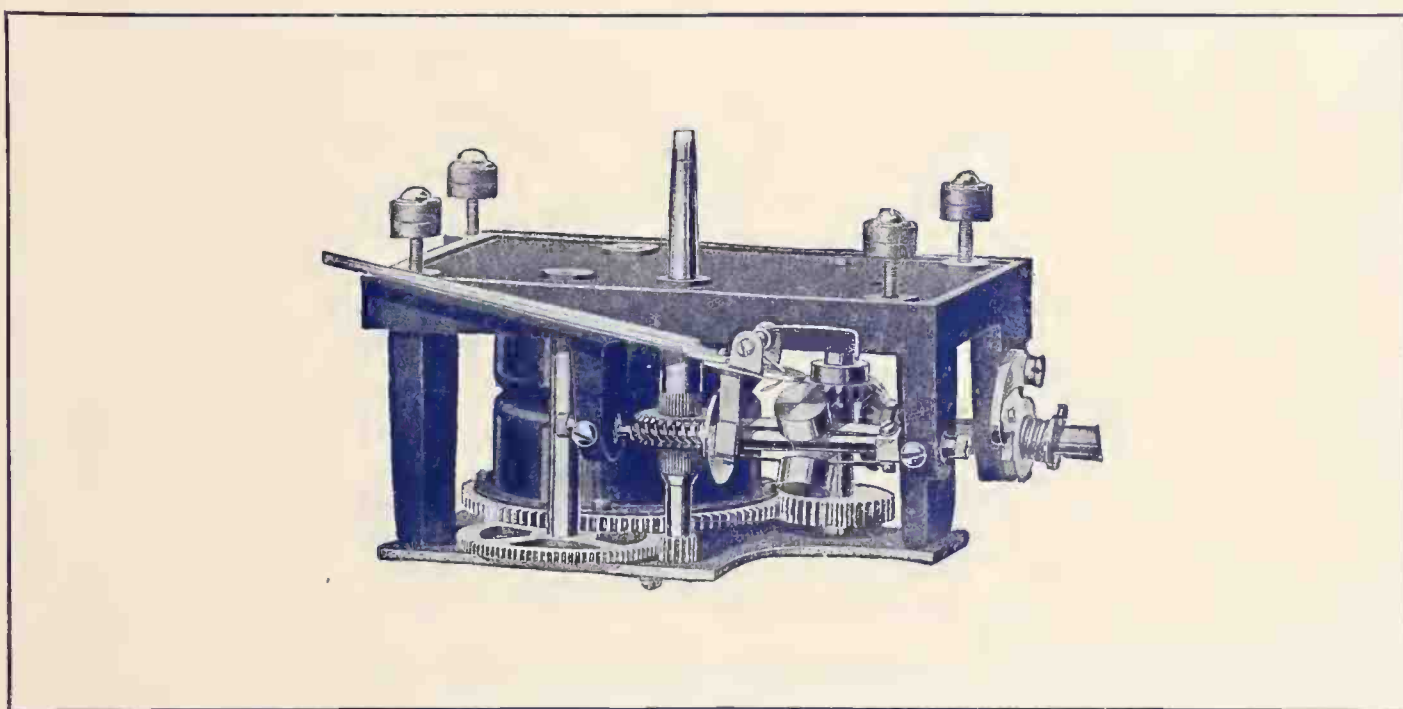

THE HEINEMAN MOTOR No. 77

Our Service Department will help you with your manufacturing problems. Trained men, skilled in phonograph building, will give you their opinions on any points you desire.

This service is valuable although free, and involves no obligation on your part. Write us today.

## GENERAL PHONOGRAPH CORPORATION

25 West 45th Street

OTTO HEINEMAN, Pres.

New York City, N. Y.

FACTORIES: Newark, N. J. Elyria, Ohio Putnam, Conn. Springfield, Mass. Kitchener, Ont.

BRANCHES: Chicago, Ill. San Francisco, Cal. Toronto, Can.







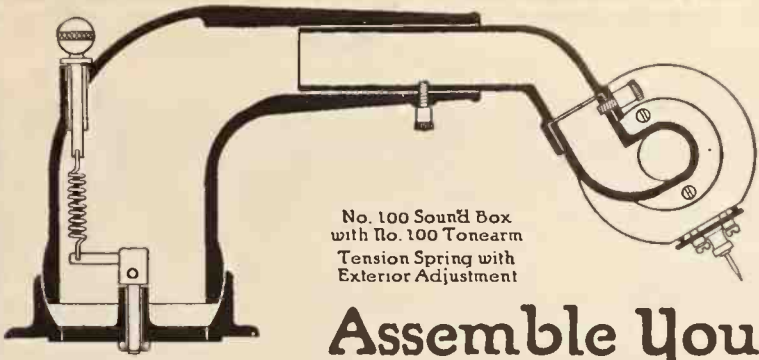

No. 100 Sound Box  
with No. 100 Tonearm  
Tension Spring with  
Exterior Adjustment

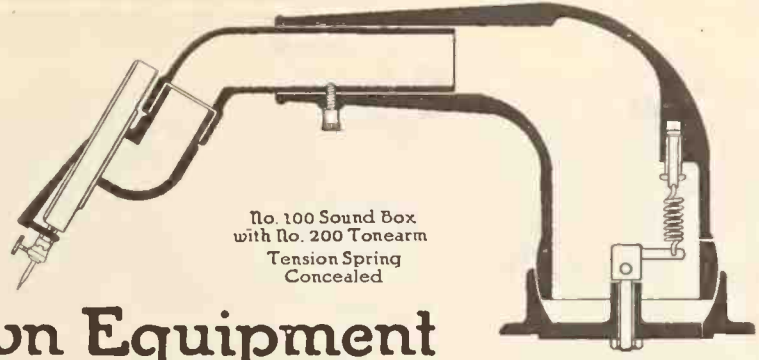

No. 100 Sound Box  
with No. 200 Tonearm  
Tension Spring  
Concealed

## Assemble Your Own Equipment

WE OWN the Dies for producing the Die Cast parts of the above Sound Box and Tonearm designs, and furnish Die Castings to large users at no expense for Dies

SPECIAL Connections can be produced for adapting any make of Sound Box to these Tonearms. Prices on application. Samples sent prepaid upon deposit of \$1.50

Die Casting  
Department

**Barnhart Brothers & Spindler**

Monroe & Throop Streets  
CHICAGO

### EIGHTEEN BASIC CLAIMS ALLOWED

Patent Office Informs Arrow Corp., of Cleveland, That Its Eighteen Basic Claims for Lateral Records Have Been Allowed

CLEVELAND, O., April 5.—The Arrow Phonograph Corp., of this city, manufacturer of Arrow records, was advised recently by its attorney, George W. Case, that the eighteen essential, basic claims for Arrow lateral records have been allowed by the Patent Office at Washington. F. W. Matthews is the inventor of this record and is also in charge of the company's recording laboratories. The eighteen claims allowed by the Patent Office are as follows:

1. A master sound record having a laterally undulatory record ridge formed from the surface layer of the record body.
2. A master sound record having a laterally undulatory record ridge formed integral with the body of the record.
3. A sound record having a laterally undulatory record ridge formed integral with the body of the record by the action of a recording tool.
4. A sound record having a laterally undulatory cut sound record ridge.
5. A sound record having a laterally-undulating cut sound record ridge of substantially uniform height.
6. A sound record comprising a body portion and a laterally undulatory record ridge, the record-forming sides of which are below the original surface of the record body.
7. A disc sound record having a laterally-undulating spiral cut sound record ridge of substantially uniform height.
8. The herein described improvement in the making of sound records, which consists in cutting a laterally undulatory record ridge into the surface of a suitable material, by means of a stylus vibrated in accordance with the sounds to be recorded, and producing from the ridge record thus obtained, a reversed or grooved record adapted to play in conjunction with a single-point reproducing stylus.
9. A sound-recording stylus having two cutting prongs arranged side by side.
10. A sound-recording stylus having two prongs arranged side by side and provided with converging cutting edges at their adjacent or inner portions.
11. A sound-recording stylus having two prongs arranged side by side and provided with converging cutting edges at their adjacent or inner portions and with diverging outer edges.
12. A sound-recording stylus having an arched groove in its lower surface, forming cutting prongs at each side of said groove.
13. A sound-recording stylus grooved or notched at its lower end to form cutting prongs.
14. A sound-recording stylus having its lower surface inclined upwardly and rearwardly, and grooved in direction from front to rear to form prongs.
15. A sound record comprising a body portion and a

record ridge whose record-forming portions are below the original surface of the record body.

16. A sound record comprising a body portion and a record ridge having a transversely rounded outer surface and substantially parallel side walls extending from opposite sides of said outer surface to the body portion of the record.

17. A sound record comprising a body portion and a laterally undulatory ridge corresponding to sound waves and projecting from and integral with said body portion, and outer surface of said ridge being transversely rounded in cross-section.

18. The method which consists in cutting simultaneously like undulations in both sides of a cutting ridge by means of a laterally-vibrating tool having cutting edges in simultaneous engagement with opposite sides of such ridge.

### WM. PHILLIPS' IMPORTANT POSTS

William Phillips, of the Mutual Talking Machine Co., Inc., New York, states that he is not the selling agent for the various companies he is connected with, as an unfounded rumor in the trade describes. Mr. Phillips is president and general manager of the Mutual Talking Machine Co., Inc., and the Supreme Phono Parts Co., Inc., and is treasurer of the Manhattan Phono Parts Co., Inc. Mr. Phillips is also actively in charge of the William Phillips Service. This service is for the talking machine manufacturer and has an engineering department acting in an advisory capacity to manufacturers in the various problems which may arise from time to time. Its especial mission has already been greatly appreciated.

### McCARTNEY RIVALS PAUL REVERE

Drives From Los Angeles to San Francisco in One Night to Attend Sales Conference

The midnight ride of Paul Revere was tame in comparison with the midnight ride recently taken by Charles McCartney, who is in charge of the Walter S. Gray Co.'s business for Southern California, and Mr. Gray, the president of the company, who had been visiting Mr. McCartney in Los Angeles. They left the Alexandria Hotel at 2:45 o'clock on Thursday afternoon; had dinner at Lebec's, midnight supper at Fresno, and arrived in San Francisco at 10:15 Friday morning, covering a total of twenty and one-half hours in fifteen and one-half hours' running time. Mr. McCartney drove the entire distance the whole night long to get to San Francisco to attend a sales conference of the Walter S. Gray Co. forces. This is somewhat of a record.

### RASHALL SALES CORP. ORGANIZED

Among the recent incorporations in the music trade in New York City is that of the Rashall Sales Corp., which has been organized with a capital of \$10,000 to do a general business in pianos and talking machines. The incorporators are F. Klein, D. Price and E. G. Wigan, 253 West Forty-second street.

## Announcing



## THE JOHN ELLIOTT CLARK CO.

156 S. W. TEMPLE STREET  
SALT LAKE CITY - UTAH

## A NEW HOME FOR VICTOR SERVICE

This organization is equipped to give exceptional service to Victor Dealers. It is a service directed along practical, efficient lines, and is based on ideas and policies that will interest and please the progressive Victor Merchant

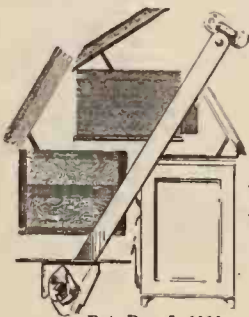

### New Automatic Cover Support

Practical—Inexpensive  
Fool Proof

Made in two different styles  
No. 1 Fit Cover at any angle  
No. 2 Hinge Plate bent to Fit Cover

Samples on Request  
Quantity Discount

Pat. Dec. 9, 1919

AUTOMATIC COVER SUPPORT MFG. CO.

77-81 MILL STREET

BLOOMFIELD, N. J.



## TWO OHIO DEALERS WHO VALUE UP-TO-DATE EQUIPMENT

C. J. Schmidt Co., Tiffin, O., and Aldrich-Howey Co., Cleveland, Have Attractive Establishments in Which Modern Equipment Is Utilized to Advantage in the Development of Sales

There are presented herewith illustrations showing the warerooms of these two very successful Victor dealers in Ohio. These Victor representatives, the C. J. Schmidt Piano Co., Tiffin, O., and the Aldrich-Howey Co., Cleve-

the city of Tiffin and at the entrance of the store a bulletin board is placed upon which are listed all of the musical events which are scheduled for that city. Mr. Schmidt, who is a thorough musician, is working in close co-opera-



A Portion of the Victrola Department, C. J. Schmidt Piano Co., Tiffin, Ohio



A Corner of Demonstration Booth of the Aldrich-Howey Co., Cleveland

land, O., are handling Victor products exclusively and through the use of progressive merchandising methods and consistent advertising have built up profitable clienteles in their respective localities.

In a recent issue of *The Total Eclipse*, the house organ published by the Eclipse Musical Co., Cleveland, O., Victor wholesalers, there appeared an interesting résumé of the ideals and accomplishments of these "live" dealers. The Schmidt store has a reputation of having the most novel and attractive window displays in

tion with C. H. Hershberger, manager of the store.

The Aldrich-Howey Co. became a Victor dealer in September, 1918, by taking over the Cleveland Piano Co., and at that time three small booths served their purpose. From this modest beginning the business developed so rapidly that they installed a separate and exclusive Victor department, which is one of the finest in the Cleveland district. Mrs. Loretta B. Flading is the manager of the department, assisted by Miss Beatrice Mowatt.

## A. H. DODIN IN NEW QUARTERS

Well-known Repairman Opens Retail Store at 28 Sixth Avenue, New York

Andrew H. Dodin, the well-known talking machine and repairman, has moved from 176 Sixth avenue to new quarters at 28 Sixth avenue, near Fourth street, in the heart of the rapidly developing Greenwich Village section, where he has opened an attractive store and will sell talking machines and records, in addition to continuing his repair work.

In his new quarters Mr. Dodin will feature the Orea and other makes of talking machines, together with Emerson and other lists of records. He has installed two booths and will pay particular attention to the handling of Italian records among the foreign lists.

Mr. Dodin's repair business has increased steadily and he now handles the work of dealers throughout Greater New York and a wide suburban district. The new store

provides room for the increase of facilities for making rapid repairs for the trade.

### INCORPORATED

The Century Talking Machine Co., New York, has recently been incorporated by H. Gray, S. H. and P. Bergmann, 109 India street, Brooklyn, N. Y. The capital is \$10,000.

Emerson records are now carried in Detroit, Mich., by six Adora Phonograph stores.

# SWISS JEWEL COMPANY

165 BROADWAY, NEW YORK, N. Y.

MAIN OFFICE AND FACTORIES:

Locarno and Geneva, Switzerland

Capital Frs. 2,250,000

The largest manufactory in Switzerland of high grade

## PHONOGRAPH NEEDLES

in Diamond and Sapphire. Watch, meter and compass jewels.

Our goods are manufactured of the very best material.

Quick deliveries, reasonable prices.

Ask for our price list and samples.





OUR NEW ADDRESS  
**347**  
**Fifth**  
**Ave.**  
 SUITE 1003  
*at 34th Street*  
 NEW YORK CITY

# BRILLIANTONE

## STEEL NEEDLES

- SOFT TONE
- LOUD TONE
- MEDIUM TONE
- EXTRA LOUD TONE
- COMBINATION TONE
- PETMECKY MULTITONE
- UNIFORM HARDNESS
- UNIFORM POINTS
- UNIFORM LENGTH

*Admittedly*  
*Just a Little*  
*Better Yet They*  
*Cost No More*

*Made in America by Americans*

**BRILLIANTONE STEEL NEEDLE CO.** OF AMERICA INCORPORATED

**REMOVED TO** **347 Fifth Avenue**  
 SUITE 1003 *at 34th Street*  
 NEW YORK CITY





THE FULTON-DRIGGS & SMITH CO., WATERBURY, CONN.

LETTERS such as the one reprinted here and illustrations of Unico Equipped stores such as shown above are constantly coming to us. They are testimony from progressive men in your own line of business, and therefore of the most direct bearing and real value for you, when contemplating improvements in the sales efficiency of your store.

Unico Equipment will help you to handle bigger business to best advantage. It has been devised and designed to utilize to the utmost all the available floor and wall space. It facilitates orderly stock display and easy handling of your wares. This means quicker and better service to your customers and less waste of time for your employees.

Prompt shipment from stock in ten designs enables you to complete your improvements quickly, Unico Equipment reaching you finished, glazed, and fitted ready for assembly and use.

Write for our booklet "Musical Merchandising." It contains full information concerning the vital Unico Advantages.

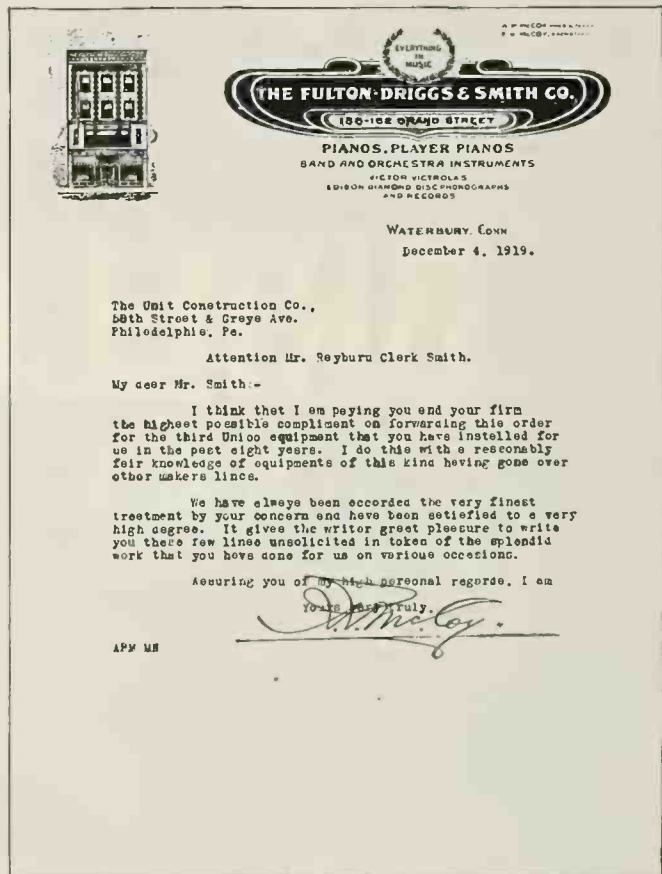

Send us today dimensions of your floor space. Plans and estimates will be submitted promptly without cost.

# UNIT CONSTRUCTION COMPANY

Unico Construction is Patented

NEW YORK  
299 Madison Ave  
Corner 41st St.

Rayburn Clark Smith...President  
58<sup>th</sup> Street & Grays Ave.  
PHILADELPHIA

CHICAGO  
Lyon & Healy Building

Unico Designs are Patented





## FATE GRANTS A SOLDIER'S WISH

Popular Columnist in Evening Sun Pictures Dramatic Episode in Life of Hurrying Crowds—Ponselle Has One Sympathetic Hearer

Impatiently awaiting the turn of the tide that would allow her to cross Fifth avenue and keep an engagement for which she was already late, the Woman teetered on the curb at Forty-second street. Near her stood a pleasant-faced chap with a silver star in his lapel. He was in no hurry to go anywhere at all, to judge by his attitude. Just as the policeman blew his whistle a taxi came to a stop beside the pavement and from it stepped a lady and a gentleman. He was in faultless evening dress. Beneath her fur wrap gleamed a gown of metal brocade.

"We will decide it now," said he. "Will you come or will you not?"

"Oh," she entreated, "couldn't we go some place else first? We could dance and go there afterward, couldn't we?" Her voice was discontented—almost a whine.

"Betty," said he, "you are simply trying to be as disagreeable as you know how. It may please you to hear that you are succeeding admirably. We are now going home."

He took two tickets from his pocket and looked around irresolutely. The Woman and he of the silver star were the only observers of the little scene, and to the obviously interested youth he handed the tickets.

"These are for a concert at Carnegie this evening," said he. "Ponselle is to sing; I hope you'll like it." And helping the astonished young lady into the taxi, he drove off.

For a moment the youth stared at them in amazement. Then he exclaimed, "Ponselle! Oh, by gosh. I never expected to hear her except on a Columbia record. That guy must be my fairy godmother." Then to the Woman, who was listening in amusement, "Say, lady, will you come?"

"Sorry," she returned, "but I have an engagement."

"Well. I can get a buddy to go," said he, and strode off.

Whereupon the Woman hurried on her way, wondering what was taking place between Betty and her escort in the taxi.

Ordinary ability, backed by the driving power of concentration, will accomplish far more than extraordinary ability that is flung broadcast. Will some trade members take notice?

## JOINS IROQUOIS SALES STAFF

Harry H. Dahl Has Been Closing Number of Important Accounts in Eastern New York and Eastern Pennsylvania—Outlook Pleasing

BUFFALO, N. Y., April 5.—Harry H. Dahl, who was recently appointed a member of the traveling staff of the Iroquois Sales Co., of this city, is achieving pleasing success, and has been closing important deals in his territory.



Harry H. Dahl

Mr. Dahl covers eastern New York and eastern Pennsylvania, and during the past few weeks has signed up contracts with representative dealers who will handle the Master-Tone phonograph and Okeh records in their respective territories.

L. M. Cole, general sales manager of this company, reports a constantly increasing demand for the Master-Tone phonograph, and according to present plans an intensive merchandising campaign will be inaugurated whereby maximum co-operation will be offered Master-Tone dealers. Mr. Cole states that the demand for Okeh records is far beyond expectations, and that it is solely a question of receiving sufficient merchandise to supply the requirements of the company's dealers.

## VICTOR CO. VS. JOHN WANAMAKER

The Victor Talking Machine Co. has been awarded a preliminary injunction against John Wanamaker, New York, from infringing the Johnson Talking Machine Patent, No. 814,786. This patent had been previously sustained in the same court against other defendants after final hearings.

The present decision was handed down on March 13 by Judge Learned Hand, of the United States District Court, New York, after a spirited contest. This is the suit which was filed in January, 1920.

Jansen & Joosten, prominent talking machine dealers of Bloomington, Ill., have purchased the O'Reilly building in that city and will open a greatly improved store in that location in a few months.



## Putnam-Page Company

VICTOR DISTRIBUTORS  
PEORIA, ILL.

¶ Roy Page, secretary of this company, has returned from a month's stay at the Victor factories in Camden, where he went to augment his already wide knowledge of Victor retail sales methods. ¶ His factory work included a thorough study of the course in Red Seal record selling—a comprehensive survey of modern Victor educational methods and a general survey of dealer helps as advocated by the Victor Sales experts. ¶ Since his return from serving as a lieutenant in the navy, Mr. Page has been building on his former retail knowledge. Our established service department will have the full supervision of Mr. Page, and dealers and dealers' employees will find us well qualified to give them constructive help in promoting their Victor knowledge—as well qualified as the best effort on our part can make us. ¶ You can expect to hear more of our service work later.

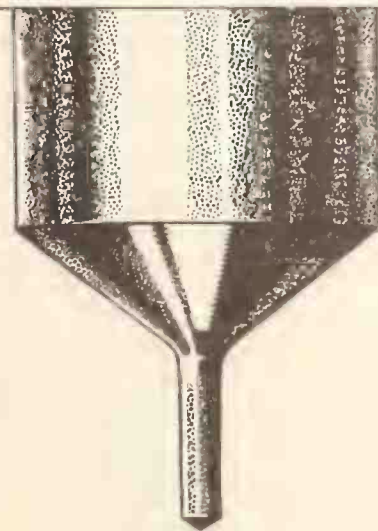

## Moneymakers!

THAT'S what these needles are—moneymakers for you. In distributing these needles you have the benefit of adding to your list of patrons and satisfied customers. These needles are for use on ALL MAKES of steel needle lateral cut records.

# Sonora

Semi-Permanent

## NEEDLES

give wonderful satisfaction. They are preferred by the public. They are well known through extensive, continuous advertising.

They are put up attractively and sell easily and quickly. No matter what makes of phonographs you handle you need these famous Sonora needles.

They play many times, sweeten the tone and increase the records' life.

Your customers are asking for these. Place your order at once to secure prompt delivery.

Loud — Medium — Soft

25c. per card of 5  
(40c. in Canada)

Sonora Phonograph  
Company, Inc.

GEORGE E. BRIGHTSON, President  
279 Broadway, NEW YORK

Canadian Distributors:  
I. Montagnes & Co.  
Toronto

**Caution!** Beware of similarly constructed needles of inferior quality.



**HELPFUL SUGGESTIONS ON GETTING FARMER BUSINESS**

Prosperity of Farming Community Illustrated in Striking Figures Demonstrates That There Is a Big Field for Sales of Talking Machines and Records if Developed

The Dealer Service department of the Columbia Graphophone Co. recently prepared an interesting sales argument for Columbia dealers, entitled "Getting Farmer Business," reading as follows:

"The farmer as a class has the financial power to procure the finer things of life and to purchase expensive commodities and luxuries that, a few years ago, were far beyond his reach.

"At the present time in the United States there are more than 6,000,000 farms. There are more than 15,000 farms of 1,000 acres and over 800,000 farms of 20 acres or over, the farms of 50 acres or over reach a total of more than 1,400,000. This is a small indication of the vast field for farm business that is open to phonograph dealers.

"The more efficient conduct of farm work has produced an average per capita income of the farmer of \$1,600 per annum in the agricultural

sections and not far below this average taking the country as a whole. The actual purchasing power of this sum equals the four or five thousand dollar city worker's income. Living under moderate conditions, he is receiving a salary equivalent to that of the city business clerk, whose living expenses are much heavier. The farmer, therefore, is really financially better off to-day than the city man.

"The farmer has in recent years been educated to an appreciation of the highest type of merchandise. He is just as discriminating in his choice as those in other walks of life, is the reader of all high class magazines and the advertisements that they carry. He is characteristically a careful buyer, showing great deliberation in his final choices, which incidentally must be the choices of his family. A special appeal to the farmer's family is therefore necessary and nothing is better than to get a Grafonola and

some Columbia records right into the farmer's home on a week's or ten days' trial.

"The education of the farmer's family is a greater factor to-day than ever before, which fact has considerable bearing on the question of merchandise. The educational value of the Grafonola and Columbia records is a strong point to play up in going after farmer business.

"While it is true that the farmer is necessarily a large mail order purchaser, he does, nevertheless, considerable shopping. The sale of really expensive necessities or luxuries is usually made personally, either in the farmer's home or when he visits the city shop. At any rate, the rural, like the city trade, demands strictly personal selling. Quite naturally the greater bulk of farmer business is done by the nearest general stores, but the city dealer has an advantage over the country dealer on account of the prestige that the city location has established.

"The Columbia Graphophone Co. is giving its dealers advertising representation in farm papers, which places Columbia product, the Grafonola and Columbia records as the third largest advertised product in the country.

"For Columbia dealers who wish to capitalize on our large advertising investment among the farmers we are suggesting the following selling plans:

"No. 1.—Circularization is perhaps the greatest medium aside from farm papers that is offered dealers for getting in touch with the farmer. In order to build up a farm mailing list local county voting poll lists may be consulted and other sources for securing names of prosperous nearby farmers are available from church registers, municipal directory books and real estate records.

"No. 2.—The rolling store offers excellent possibilities for 'buy-in-the-home' service. It is quite a simple matter for any dealer to take his large delivery truck, fit it out with several cabinet type Grafonolas and a substantial selection of records, principally those listed in the booklet, 'Musical Menus,' published by the Columbia advertising department, and go out into the rural districts installing complete outfits on trial in the homes.

"No. 3.—In that the farmer gets around more in the Summer than during the hard Winter months, the bid for a large volume of farmer business can be made by direct invitation to the store. The arrangement of suitable concerts and recitals given on certain days, advertised through the farm mailing list by means of a neatly printed invitation card, will attract many from the outlying districts."

**DOING WELL WITH THE PATHE**

Economy Variety Store, Centralia, Ill., Selling Large Numbers of Pathé Machines

CENTRALIA, ILL., April 6.—The Economy Variety Store, of this city, is doing big things with the Pathé line which it carries. The latest census reports give the population of Centralia as 12,000, and there are seven other lines of phonographs sold in this town. E. S. Holland, manager of the phonograph and record department, is successfully meeting this competition and has laid plans for 1920 that will enable his firm to eclipse all former records.



**HIGHEST QUALITY—LATEST HITS  
A LIVE ORGANIZATION**

*Write At Once for  
Dealer's Terms, Etc.*

***Immediate Deliveries***

**Lyraphone Co. of America**

117 Mechanic Street

Newark, N. J.

**TALKING-MACHINE**

**CABINETS**

**FOR THE TRADE**

**GLENWOOD CABINET MFG. CO.**

S. E. Cor. 22nd and Glenwood Ave.  
PHILADELPHIA, PA.



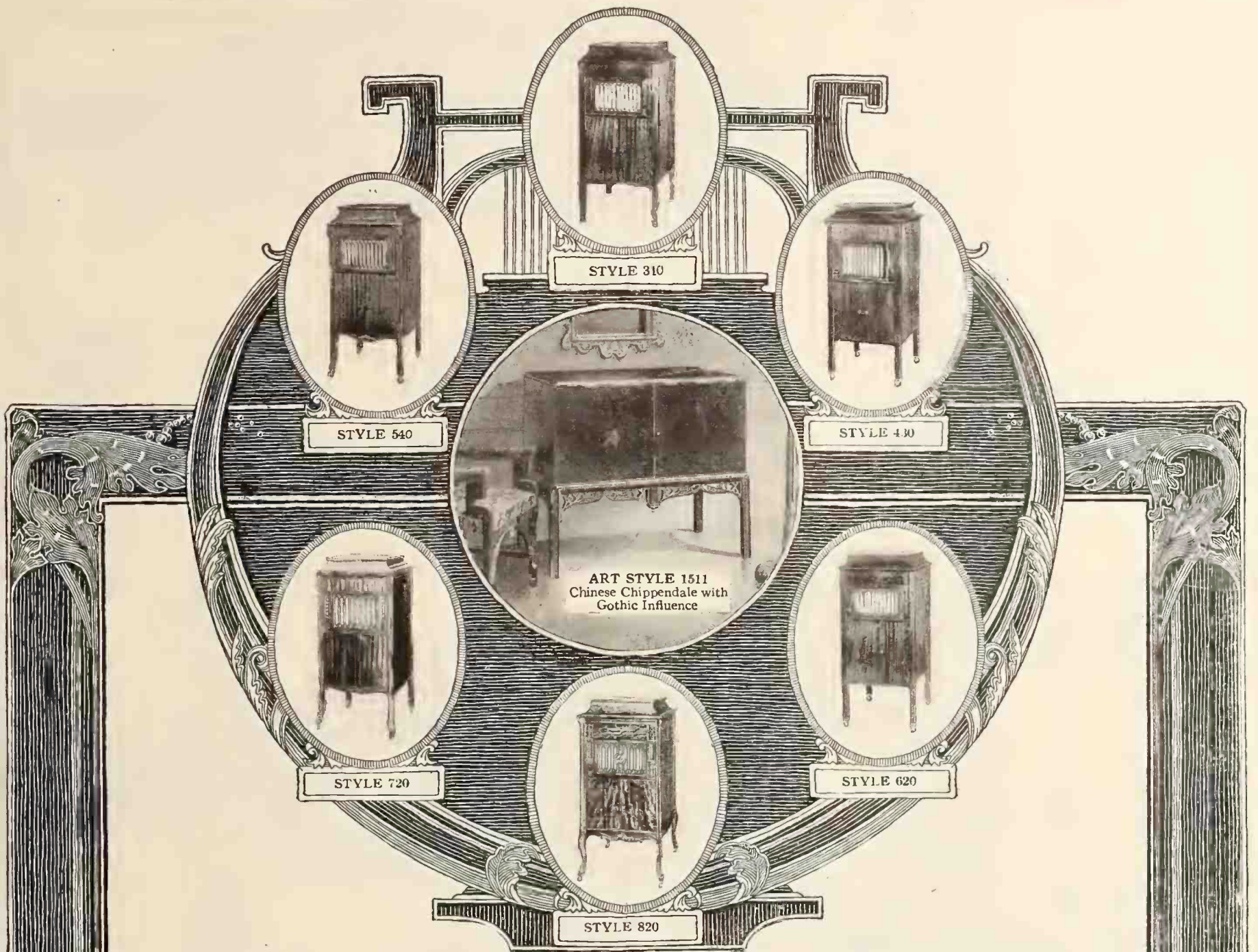

# THE AEOLIAN-VOCALION

*The Phonograph Created and Manufactured  
by Master Musical Instrument Makers*

**DISTRIBUTORS**

*for*

SOUTHWESTERN OHIO  
SOUTHEASTERN INDIANA  
KENTUCKY and TENNESSEE

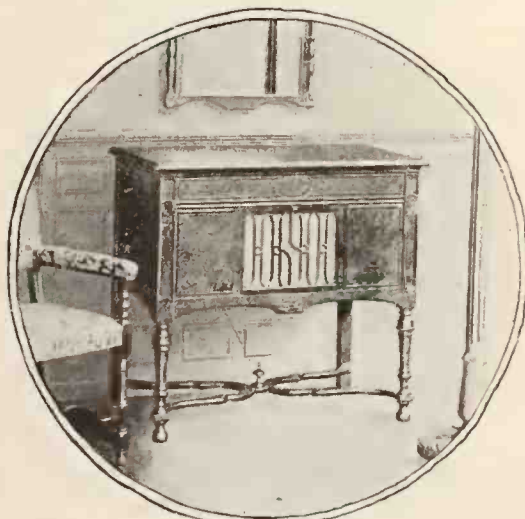

ART STYLE 1497  
William and Mary—1689-1702

**The AEOLIAN  
COMPANY**

25 WEST FOURTH ST.  
CINCINNATI

## VOCALION RECORDS

LATERAL CUT

PLAY ON ANY STANDARD PHONOGRAPH

*Made by Tone Production Experts*



**PRESENT FEDERAL TAX A BURDEN**

President of Columbia Graphophone Co. Points Out Need for Legislative Action

The report of the Columbia Graphophone Co. for the year ended Dec. 31, 1919, shows a net profit after the deduction of all charges and Federal taxes amounting to \$3,624,202, which, after the deduction of preferred dividends, was equivalent to \$3.32 a share earned on the 858,471 shares of common stock of no par value outstanding.

The company's earnings from all sources during the year, before the deduction of any charges, were \$7,793,044. A reserve of \$3,624,202 was set aside to meet Federal taxes and the report shows a profit and loss surplus of \$2,864,544.

Francis S. Whitten, president of the company, in his remarks to stockholders said:

"The year just closed has been in many respects a most unusual one, and your company would have shown much larger net earnings were it not for the unfavorable Federal tax law now in operation, which resulted in over 45

**"A Million A Year"**  
WHAT'S YOUR SHARE OF  
**MICA DIAPHRAGMS OF BEAUTY**  
—Phonographically Speaking—They Talk for Themselves—  
*Manufactured for over ten years for the larger consumers by the*  
**INTERNATIONAL MICA COMPANY**

Factory and	{ 37th & Brandywine Sts.	Mines,	Executive	{ 1228 Filbert St.,
Sales Dept.	{ W. Philadelphia, Pa.	Amelia Co., Va.	Dept.	{ Philadelphia, Pa.

*Send for samples and quotations now and eliminate your diaphragm difficulties*  
Immediate delivery of small quantities can be made in the following districts.  
SAN FRANCISCO, CALIF.—WALTER S. GRAY  
CHICAGO, ILL.—LAKESIDE SUPPLY COMPANY  
MONTREAL, CAN.—ARTHUR K. KEMPTON

per cent of the company's net profits in 1919 being paid the Federal Government as taxes.

"It is to be hoped that Congress will take action in 1920 which will change this unwise law and permit your company to show earnings which will reflect the unceasing effort of the management during the last three years to make your company the leader in the talking machine industry."

**THAT DIFFICULT NAME WINS AGAIN**

Reinald Werrenrath Finds Hostile Cop Turns Friendly as He Recognizes the Owner of the Famous Voice—License Plates Forgotten

In the past belligerent years Reinald Werrenrath found his voice valuable for entertaining soldiers in hospitals and camps and other purposes, but never until recently did he realize that it was potent to prevent his arrest.

The baritone had just returned from a concert tour of the Middle West and during his absence the 1919 license of his motor car had expired. Not having been in the city to get new plates, Mr. Werrenrath ventured down town in his car with his old plates. Within a few blocks of the license bureau a policeman stopped him and ordered him up to the nearest curb.

"But just a minute," protested Mr. Werrenrath, trying to interrupt the policeman's note-taking. "I am on my way now to get new plates. I was out of town when my license expired, and my official notice failed to reach me because my name was incorrectly spelled. It isn't an easy name . . ." ("Old stuff," said the policeman) . . . "and to prove it, I'll let you be the judge," and Werrenrath held out his card.

The policeman looked him in the face for the first time since taking out his little black pad.

"Say," he burst out, "your records are getting too expensive, and I wish you'd do something about it, because I like 'em. Oh, well, I can't give a pal a summons. I couldn't give any one with a voice like yours an 'order.' I used to be your cop up at New York University Heights, and I always came over to the university for all your concerts. Sure, I know 'Big John,' the night watchman, and you and the whole crowd. Oh, it's all right. Go over and get your license, and if any of the other fellers stop you, just tell them old D—said it was a go."



**OPEN NEW BRUNSWICK DEPARTMENT**

PADUCAH, Ky., April 3.—The E. Guthrie Co., Inc., is making preparations to open a large talking machine department under the direction of J. H. Switzer, where the Brunswick line of machines and records will be carried. The opening of this new department of the E. Guthrie Co. marks a considerable expansion in the business policy of the company, and Manager Switzer is laying plans which call for intensive cultivation of his territory, which is an extensive one.



**ASTORIA MAHOGANY**

**LUMBER and VENEERS**

Left: Logs in Africa ready for delivery to coast.  
Right: Raft of logs being towed out to steamer in Mexico

**Serving You at the Source of Supply**

I N dark Africa and turbulent Mexico our trained experts are constantly exploring the important mahogany producing timber lands, selecting logs for direct shipment to us—frequently in our own bottoms.

This is another element in the service which, after nearly half a century, has made us the largest complete organization in the United States.

**Astoria Mahogany Company, Inc.**  
347 Madison Avenue, New York

Successors to  
Huddleston-Marsh Mahogany Co.  
Astoria Veneer Mills and Dock Co.  
F. W. Kirch, Inc.

Mills and Yards, Long Island City, New York

**BRANCHES:**

44 North Market Avenue  
Grand Rapids, Mich.

2256 Lumber Street  
Chicago, Ill.

CAST

PRECISION

CAST

---

PRECISION CASTINGS COMPANY, INC.  
SYRACUSE, N. Y. NEW YORK.

Manufacturers of Die Castings in  
**Aluminum, Zinc, Tin, Lead Alloys,  
Babbitt Bearings**



NEW YORK

CHICAGO

QUINCY, ILLS.

OTSEGO, MICH.

DAYTON, OHIO.



**TRADE MARK**

MODEL A

MODEL B

MODEL C

MODEL D

MODEL E

MODEL G

# THE PHONOGRAPH OF PERFECTION

SCIENTIFICALLY CONSTRUCTED      PIANO FINISHED  
 WHOLESOME NATURAL TONE      LOUDEST OF VOLUME  
 LATEST AND BEST MODIFIER  
 OUR OWN PATENTED HORN  
 IMPROVED PERFECT SOUND BOX  
 BALL-BEARING TONE ARM  
 LATEST TYPE OF GUARANTEED MOTOR  
 NEW BEVEL EDGE TURNTABLE

**KESNER & JERLAW**  
 PRODUCERS OF  
**Exclusive Phonographs**  
 FOR THE  
**Jobbers and Large Distributors**

Every Phonograph Is  
**GUARANTEED FOR ONE YEAR**  
 Against All Manufacturer's Imperfections

Write For All  
 Information and Particulars to Either Address

**M. L. KESNER**  
 47 West 34th Street  
 New York  
 Telephone Greeley 6251

**N. JERLAW**  
 316 So. Clark Street  
 Chicago  
 Telephone Wabash 2646







**Rosa Ponselle's greatest record yet is that tragic aria "Suicidio" from Ponchielli's *La Gioconda*. Columbia Record 49735.**

**Columbia Graphophone Co.  
NEW YORK**



### THE TRADE SITUATION ANALYZED

W. P. White, Sales Manager of Paramount Talking Machine Co., Discourses on Conditions Observed on Recent Visit to Important Trade Centers Throughout the Country

PORT WASHINGTON Wis., April 5.—W. P. White, sales manager of the Paramount Talking Machine Co., of this city, manufacturers of Paramount talking machines and records, returned recently from an extensive trip, which included a visit to Kansas City, Oklahoma City, Dallas, Houston, New Orleans, Birmingham, New York, Philadelphia, Pittsburgh and other important trade centers. On this trip Mr. White made a careful investigation of general trade conditions and his reports of the industrial outlook in different parts of the country are very optimistic.

Referring particularly to the talking machine industry, Mr. White made the following pertinent comments, based on his observations on this trip.

"We are going to remain in business just as long as we continue to make money; enough money to justify the overhead expense, carry the interest on the investment and show a satisfactory margin of profit, sufficient to enable us to branch out and grow.

"Progress? For the past few years there has been a continual storm of 'monkey wrenches' directed toward the talking machine industry. We have been at war; we have had law suits; we have had to contend with competition of an extremely disagreeable nature; we have been troubled with industrial unrest; transportation

difficulties and what not. It became necessary for large manufacturers to curtail their output of machines and records to assist the Government, much to the detriment of jobbers and dealers, who lost heavily.

"Manufacturers, wholesalers and dealers, the trinity were dashed into a period never to be forgotten in our history. Analyzing causes removes all doubts of the source from which the situation developed. It remains for us to analyze the existing situation, endeavor to eradicate that which causes the difficulties and make a strenuous effort again to place the industry on the dignified basis which it assumed in 1915.

"Dealers in every city have been menaced. They have been unable to secure enough goods of a thoroughly reliable nature to operate intelligently. Because of this condition their future reputations have been placed in jeopardy, but it was essential for them to remain in business regardless of this, in order to pay expenses.

"Next question. Are the dealers in favor of permitting this same condition to continue? Is it possible they are blind to its pitfalls? No sane business man will jeopardize his reputation or the firm's good will. America is not a nation that, willingly or knowingly, steps backward. The disposition is to develop and improve. What are talking machine dealers doing to improve their own condition and that of the industry?

"A concerted movement must be instituted to stop this backward movement and State organizations should become active immediately unless they countenance the existing degrading influences. There are many thousands engaged in this business who are well-educated men, men

who conduct their business on a dignified basis and continue to develop the dignity of the industry. These are the men who should take action. They are making money now, but what of the future? At the present rate of speed, which has been checked, fortunately, the industry would have sunk to a level beneath the dignity of the higher type of organizations.

"The talking machine business is intensely interesting. Those engaged in it love it. It is music; it is art; it is pleasure; it is business, and a mighty good-paying business. Why, then, permit it to lose that quality when it is possible to maintain it?

"Suppose the large manufacturers of talking machines and records were to close down their plants because no one would buy. Jobbers and dealers would have to do likewise. It's a poor rule that does not work both ways.

"Immediate large returns are forerunners of commercial black eyes. What about the future? Better take this into consideration when you place your orders for stock: Is the manufacturer thoroughly reliable? Can he guarantee the product? Is his guarantee substantial? How substantial is it? What future service will be secured? What service can be rendered to customers in the future? How rapidly will the manufacturer expand? Can he expand to meet the growth of the dealer? What is the manufacturer doing to develop the dignity of the industry? This is just as important as any of the above.

"Let every dealer ask himself the same question—What can be done to dignify the industry and develop it?

"It is a most pertinent topic."

*The Needle Once Used—Always Enjoyed*

**BEST SEMI-PERMANENT STYLUS**

*Plays 300 Records*

*No Scratch, No Hiss*

You owe it to yourself and to your customers to sell "THE MOST SATISFACTORY NEEDLE ON THE MARKET."

After once using the "BEST semi-permanent STYLUS" your customers will never use any other.

The attractive discounts, coupled with the superiority of our Needles, make the handling of the "BEST STYLUS" an asset in your business.

Samples and full particulars upon request

**THE ANSONIA NEEDLE CO.**

**ANSONIA, CT.**



# "A new Gennett!"



## ANTICIPATION

is justified by realization when the record is a **Gennett**.

If you have never heard a **Gennett** treat yourself to No. 9021. When you hear "Echoes From the Alps" and "Weymouth Chimes," played with chime effects by His Majesty's Scots Guards Band, you will have the Gennett habit.

They do *better* all phonographs—*Hearing is Believing*. Any STARR dealer will gladly play for you.

*Write for Gennett Catalog*

**THE STARR PIANO CO., Richmond, Indiana**

Los Angeles      New York      Birmingham, Ala.  
London, Canada



**ATLANTA TRADE IS OPTIMISTIC**

**Business Is Running at High Water Mark With All the Leading Establishments**

ATLANTA, GA., April 7.—Reports from the trade in this city indicate that business is running at high water mark and that the outlook for some time to come is good.

The Cable Piano Co., Victor dealer, is enjoying excellent business. Its big store has been the center of activity for some weeks on account of the sale of grand opera tickets conducted there as well as the natural activity in the talking machine business and the heavy demand for Victor product. This firm has received in the past few weeks shipments of some of the most salable models of Victrolas and has disposed of them as rapidly as they came into the Victrola department. The store has been recently entirely remodeled and the company is in position to care for a greatly increased business.

The Haverty Furniture Co., Columbia and Pathé dealers, sold during March a substantial quantity of phonographs and records and the outlook for spring business is very fine. The demand for popular records is exceedingly good and the sale of high-class records has been stimulated by the approach of the grand opera season, which begins here April 26.

The Delpheon Shop, Columbia dealers, is enjoying as fine a business as it has ever had, the holiday season not excepted, and the sale of Columbia records is steadily increasing. Miss Bannie Hood, in charge of this department, is an expert and her knowledge of records and her high-grade sales ability are putting her firm in the front rank as record seller. The sale of instruments with this firm is also continuing in nice volume.

The Phillips & Crew Piano Co., the oldest Victor dealers in Georgia, opened in Savannah, Ga., during March a branch store, fully stocked and equipped with musical merchandise, the leading lines being the Victrola as well as pianos. They anticipate doing a good business in their new store. Business in the Atlanta store is running into new figures and with some relief in sight as to available stock they hope to maintain a new and constantly increasing standard for new business.

Atlanta and the whole South Atlantic States are eagerly awaiting the annual visit of the Metropolitan Opera Company, which organization will be here the last week in April. Stars such as Caruso, Ponselle, Barrientos, Farrar, Mardones and others will arrive on April 26 and will sing for one week here, Atlanta being the only city outside of New York which has its season of Metropolitan Grand Opera.

**HOMEWARD BOUND**

B. R. Forster, president of the Brilliantone Steel Needle Co. was recently in San Francisco. From that city he visited Los Angeles and then returned East.

**ST. JOSEPH DEALERS HOLD MEETING**

**Advocate Charging of Interest on Instalment Sales of Talking Machines—Called Together by Earl Elsham of Leader Department Store**

St. JOSEPH, Mo., April 6.—The talking machine dealers of this city met in a convention called by Earl Elsham, manager of the talking machine and piano department of the Leader Department Store during the last week in March, and discussed many matters of interest to the trade. The matter of charging interest on talking machine accounts was discussed and the giving away of free merchandise with sales was condemned. It was also suggested that the Chamber of Commerce secure Frank E. Morton, acoustical engineer of the American Steel & Wire Co., to address local business men. Mr. Elsham urged very strongly that a music week be instituted in this city and all dealers expressed themselves as heartily in favor of the plan. During their stay in St. Joseph the visiting dealers were entertained at luncheon by Mr. Elsham in the tea room of the Leader Department Store. Other meetings will be held at intervals in the future.

Among the men attending the meeting were: Fred Schneider, of Townsend, Wyatt & Wall; Manager Helsell, of the J. W. Jenkins' Sons Music Co.; Manager Conner, of the Olney Music Co., and Earl Elsham, manager of the talking machine department of the Leader store.

**FAMOUS ARTISTS ARE HEARD**

**Singers Well Known Through the Talking Machine Appear in Concert to Aid Italian Loan, at Which \$3,415,450 Was Realized**

A great number of well-known artists who are popular favorites with talking machine record users helped to realize \$3,415,450 in the great drive for subscriptions to the Italian \$25,000,000 loan at a concert at the Lexington Theatre, New York, the closing Sunday of last month. Enrico Caruso sang an Italian love song which brought in \$50,000 from one of his countrymen; a lump sum from various subscribers amounting to \$50,150 was realized by Stracciari for his singing of an aria from the second act of "The Barber of Seville," and it aroused such acclaim that an encore realized \$45,000. Justice Freschi, who presided, had little difficulty in selling a song by Mme. Tetrizzini for \$30,000 to Felice Bava and in getting a \$20,000 subscription from Caruso. He also disposed of a song by Galeffi to a group of individual subscribers for about \$50,000. The Metropolitan opera chorus and others assisted. It was a wonderful evening of emotion and music, and evidenced not only the patriotism of the Italian people in America, but also their keen appreciation of the very best in music.

John Shepard, of the G. T. Williams Co., Brooklyn, N. Y., Victor distributors, was among the trade visitors in Providence last month.



**I'll Tell The World**  
 You don't need our wrapping envelopes—if you take no pride in your store or in the appearance of your package.  
 You don't need our envelopes—if you are content to sell only the record your customer asks for.  
 You don't need our envelopes—if you don't believe in advertising.  
 And don't clip this coupon—unless you are willing to rise above the level of the ordinary Victor dealer.

My Name is.....  
 The Firm name is.....  
 Our Address is.....

**LU-FRANC SALES SERVICE**  
 1231 Dime Bank Bldg. Detroit, Mich.

**DAVEGA TO HANDLE PATHE LINE**

**Machines and Records Will Be Retailled—Will Feature the Pathé in Its Four Stores**

The S. B. Davega Co. of New York City has arranged to carry a full line of Pathé phonographs and records which will prove an important acquisition to its already extensive business. The Davega Co. conducts a chain of successful stores in New York at 111 East Forty-second street, in the Hotel Commodore, 831 Broadway, 15 Cortlandt street and 125 West 125th street.

**TWO CA-NINES BATTLE ON DIAMOND**

**Two Teams of Victor Dogs in Window of Wiley B. Allen Store Make Clever Display**

SAN DIEGO, CAL., April 6.—"Vic" must have "scored a single," said an elderly gentleman in the crowd that assembled in front of the Wiley B. Allen Co. music store windows Saturday afternoon admiring the clever display showing a baseball game in progress between two teams of Victor dogs representing the Victrola and Brunswick teams. A background executed by Clyde Hill added to the setting and the little Victor trade mark dogs seemed to be enjoying themselves immensely.

The batteries for the Victrolas, Kindler and Guy, for the Brunswicks, Porter and Duryee. These are the names of talking machine salesmen and salesgirls working for the local Wiley B. Allen store. Mr. Young, manager, says the game was called on account of darkness in the fourth inning and the score ended a tie with the Brunswicks having two dogs on bases.

Miss Marie Michaud, who left the sales force of the Shepard Co., Providence, R. I., in order to attend the courses in salesmanship held at the Victor school in Camden, has completed her work and has returned to Providence and resumed her work there.



**Pathé PHONOGRAPHS**

REG. U.S. PAT. OFF.



*Plays all records—No needles to change*

**GRAY & DUDLEY CO.**  
 Distributors for The South

**NASHVILLE**      **TENNESSEE**



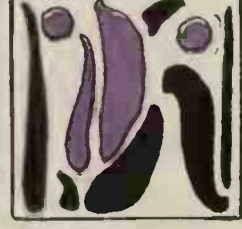
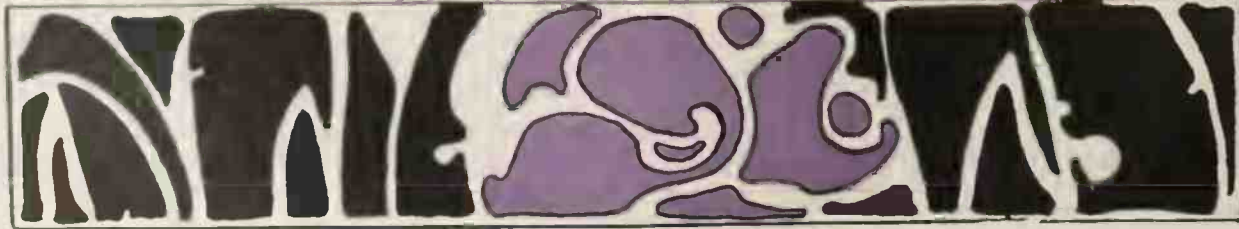
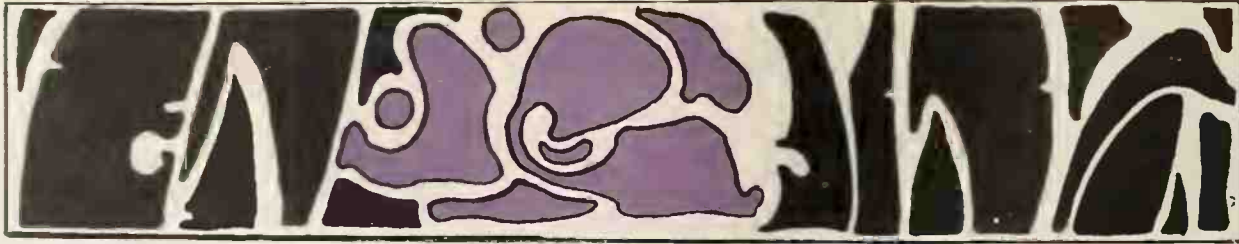
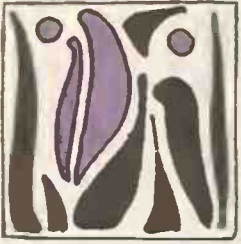

*Made right, sold right!*

“FAME is the perfume of heroic deeds,” said Socrates. “Wonderful sales are the reward of extraordinary merit,” say those fortunate dealers who handle the famous instrument which won highest score for tone at the Panama Pacific Exposition.

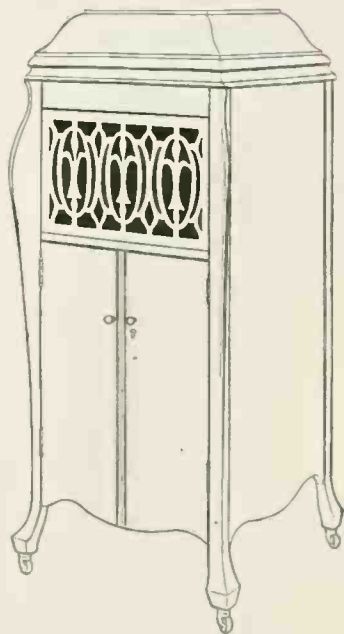
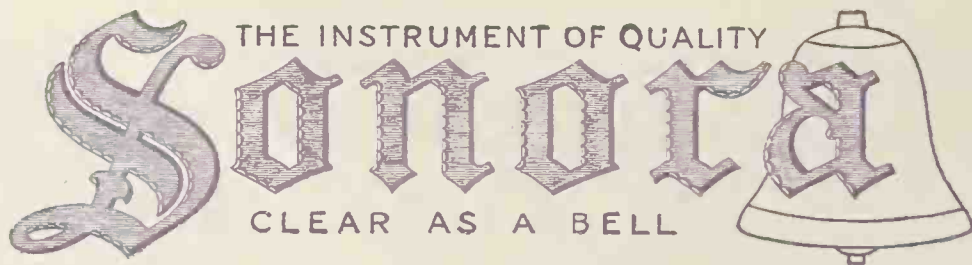

NOCTURNE

is designed—not adapted—to play ALL MAKES of disc records perfectly without extra attachments.

It is supreme in tone, unequaled in beauty of design, and unrivaled in its important features of construction.

The Sonora is sold easily, and because of its matchless value there is no difficulty in getting cash for it.

Prices \$60 to \$2500

*Sonora is the phonograph that keeps your bank balances high.*



THE INSTRUMENT OF QUALITY  
**Sonora**  
 CLEAR AS A BELL

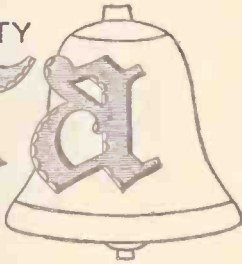

**T**HIS instrument is the only one sold without offering "easy payments" as the leading attraction. It is made for those who want the best—for those to whom quality and not terms is the important consideration. If you wish to handle the Sonora, write to the distributor for your territory.

**Gibson-Snow Co.**  
 Syracuse, N. Y.  
 State of New York with the exception of towns on Hudson River below Poughkeepsie and excepting Greater New York.

**W. B. Glynn Distributing Co.**  
 Saxtons River, Vt.  
 States of Maine, New Hampshire, Vermont and part of Massachusetts.

**Griffith Piano Co.**  
 605 Broad St.,  
 Newark, N. J.  
 Northern New Jersey.

**Hessig-Ellis Drug Co.**  
 Memphis, Tenn.  
 Arkansas, Louisiana, Tennessee, Mississippi.

**Hillman Phonograph Co.**  
 Wheeling, W. Va.  
 Virginia and West Virginia.

**Kiefer-Stewart Co.**  
 Indianapolis, Ind.  
 Entire State of Indiana.

**Lee-Coit-Andreesen Hardware Co.**  
 Omaha, Neb.  
 State of Nebraska.

**The Magnavox Co.**  
 616 Mission St.,  
 San Francisco, Cal.  
 Washington, California, Oregon, Arizona, Nevada, Hawaiian Islands, Northern Idaho.

**C. L. Marshall & Co.**  
 82-84 Griswold St., Detroit  
 409 Superior St., Cleveland  
 Michigan and Ohio.

**Minneapolis Drug Co.**  
 Minneapolis, Minn.  
 States of Montana, North Dakota, South Dakota, Minnesota.

**I. Montagnes & Co.**  
 Ryrie Building,  
 Toronto, Can.  
 Canada.

**M S & E**  
 221 Columbus Ave.,  
 Boston, Mass.  
 Connecticut, Rhode Island and eastern Massachusetts.

**Robinson-Pettet Co., Inc.**  
 Louisville, Ky.  
 State of Kentucky.

**American Hardware & Equipment Co.**  
 Charlotte, N. C.  
 North Carolina and South Carolina.

**C. D. Smith Drug Co.**  
 St. Joseph, Mo.  
 Missouri, northern and eastern part of Kansas and five counties of northeastern Oklahoma.

**Smith, Kline & French Co.**  
 Philadelphia, Pa.  
 States of Pennsylvania, Maryland, Delaware, District of Columbia and New Jersey, south of and including Trenton.

**Sonora Phonograph Company, Inc.**  
 279 Broadway,  
 New York.  
 Distributors for Greater New York.

**Southern Drug Co.**  
 Houston, Tex.  
 Southeastern part of Texas.

**Southern Sonora Co.**  
 Atlanta, Ga.  
 Alabama, Georgia and Florida.

**Southwestern Drug Co.**  
 Wichita, Kans.  
 Southern part of Kansas, Oklahoma (except five northeastern counties), and Texas Panhandle.

**Strevell-Paterson Hardware Co.**  
 Salt Lake City, Utah.  
 Entire States of Utah, Colorado, Wyoming, New Mexico and southern Idaho.

**C. J. Van Houten & Zoon**  
 Marquette Bldg.,  
 Chicago, Ill.  
 Illinois and Iowa.

**Sonora Distributing Co. of Texas**  
 Dallas, Tex.  
 Western part of Texas.

**Yahr & Lange Drug Co.**  
 Milwaukee, Wis.  
 Wisconsin, Upper Michigan

*The Highest Class Talking Machine  
 in the World*

Sonora is licensed and operates under BASIC PATENTS of the phonograph industry





## Announcement

**C. C. MOIR**

**181 Tremont Street**

**Boston, Mass.**

*Has been appointed*

**Exclusive New England Distributor**

*of the*

**L'Artiste Phonograph**

Made in Grand Rapids, Mich.

Dealers in the New England territory are invited to communicate with Mr. Moir regarding an Agency for the L'Artiste. Mr. Moir is well equipped to give the maximum of service and personal attention to dealers in his territory.

**THE PHILADELPHIA SHOW CASE CO.**

*Distributors*

Main Office:

127 NORTH 13th STREET

PHILADELPHIA, PA.

New York Office  
THE BUSH TERMINAL BUILDING  
Room 845

Pittsburgh Office  
JENKINS ARCADE BUILDING  
Pittsburgh, Pa.



**JAMES MONTGOMERY FLAGG SKETCHES MISS ANNA CASE**

Following the remarkable Edison tone test held at Carnegie Hall on March 10, the story of which appeared in full in The World last month, Anna Case, the famous American soprano

pressed by the tone reproduction of the New Edison. In the photograph he is seen drawing Miss Case as she stands beside the instrument. The inserts show, left to right: Arthur Walsh,

**FREAR BILL WOULD FIX PRICES**

**Proposes to Give Federal Trade Commission Power to Arbitrarily Fix Maximum Sale Price on Any Commodities—Drastic Penalty Would Take Away Firm's License to do Business**

WASHINGTON, D. C., April 3.—A bill has been introduced in the House of Representatives by Representative Frear which would give the Federal Trade Commission the same rights to fix the maximum price on commodities said to be unduly high priced as the Interstate Commerce Commission now has in fixing railway freight rates. Complaints would have to be made to the Federal Trade Commission that the production or price is controlled so that free competition ceases to exist before it could take steps to declare the schedule of rates under which such commodities could be sold.

The bill would provide that within 30 days after public notice of the commission's findings the prices so fixed will become effective and the monopoly or group of interests combining to keep prices up would have to cease charging the higher prices. Provision is also made for a review of the commission's findings by the circuit court, but if the decision is in favor of the Government, the manufacturer or merchandiser would have to pay the excess amount collected during the interim into the Federal Treasury.

**LIVE CONCERN IN HARRISBURG**

**C. M. Sigler, Inc., Occupies Five-Story Building With Excellent Line of Instruments**

HARRISBURG, PA., April 3.—One of the active music houses in this city is C. M. Sigler, Inc., which was established about twenty-five years ago by C. M. Sigler and operated by him until 1914, at which time it was incorporated. C. M. Sigler, founder of the business and president of the corporation, is also head of the Sigler Player Action Co., Grand Rapids, Mich. The other members of the local company are N. B. Kurzenknabe, M. A. Sigler, W. T. Rodgers and G. P. Schaeffer.

The Sigler house occupies an entire five-story building, the basement being devoted to the music roll department, first floor to Victrolas, the second and third floors to pianos, and the fifth floor to the repair department. The lines handled include the Steinway, Steinert, Christman and Apollo pianos and the Victrola.

At the present time arrangements are under way for the installation of three new booths in the talking machine department, as well as three new booths in the music roll department.



Miss Anna Case, Posing for James Montgomery Flagg and popular Edison artist, posed for James Montgomery Flagg, who is one of the most widely known modern illustrators. Mr. Flagg, who was present at the recital, was greatly impressed by the tone reproduction of the New Edison. In the photograph he is seen drawing Miss Case as she stands beside the instrument. The inserts show, left to right: Arthur Walsh, director of the recital department of Thomas A. Edison, Inc., who was in charge of the Carnegie Hall recital; Victor Young, pianist, and William Reed, flutist.

**PATHE IN MONTANA SCHOOLS**

**W. H. Wallace, Progressive Miles City Dealer, Enters a New Field of Music Advancement**

Dealers in Pathé phonographs and records will be interested to hear of the success of W. H. Wallace, the progressive music merchant and distributor of Miles City, Mont., who has installed Pathé instruments in the schools of four counties adjacent to his city. The departure has been hailed with joy by the pupils, as

the charming selections lighten their studies and add zest to the routine of the schoolroom, and it has, of course, met with the approval of their parents and teachers. Mr. Wallace has found the work so pleasant and profitable that he will follow up the plan by placing phonographs in the schools over a wide range of territory.

Under Opportunity No. 32363, the Bureau of Foreign and Domestic Commerce reports that a firm in India desires to secure the sales agency for phonographs and accessories.

**THE WALTERS & BARRY CORPORATION**

**256 MAIN STREET**

**BUFFALO, N. Y.**



PLAYS ANY MAKE OF RECORD ANY DESIRED NUMBER OF TIMES . . . . . THEN STOPS AUTOMATICALLY WITH TONE-ARM SUSPENDED IN AIR.

The First Really Complete Phonograph

**Largest Distributors of Brooks Automatic Repeating Phonographs in the United States**



The "Buddha-Dardanella" fox-trot by the Columbia Saxophone Sextette is a musical combination that means big sales. A-2876.

Columbia Graphophone Co.  
NEW YORK



### DEALERS MEET AT WILKES-BARRE

Columbia Retailers Hold Interesting Session Under Auspices of Philadelphia Branch of Columbia Graphophone Co.—Listen to Some Excellent Talks on Business Plans

WILKES-BARRE, PA., April 1.—A most interesting meeting of Columbia dealers of this city and vicinity was held recently at the Hotel Redington under the chairmanship of C. E. Sheppard, Columbia salesman covering that territory, and was attended by several executives of the Columbia Co. branch in Philadelphia.

E. A. Manning, credit manager, gave a very good detailed address on the method of placing orders and the channels through which different items should be presented to receive recognition.

W. A. Schreiner, manager Dealer Service department, gave a most instructive talk on the work and purpose of the department, explaining the origin and going into detail as to what

trouble and expense a dealer had in writing advertising copy, procuring the different fixtures, window dressing, etc., before the company established the Dealer Service department.

N. J. Wilcox, manager of the Philadelphia branch, was the next speaker to be introduced by Mr. Sheppard, and his address was based on Columbia representation. "The time has come when we can safely tell you that during the year of 1920 we will be in a position to supply you with all the products you can use. We set our quota for the year." Mr. Wilcox said, "at 100 per cent increase over 1919 and it is imperative for you to increase your sales 100 per cent for us to do this."

The meeting was a huge success and every dealer present voiced his opinion that the idea of these meetings was indeed a welcome one. Those present included Ford Price, of Fowler, Dick & Walker Co., and Joseph Corner, C. & S. Furniture Co., Wilkes-Barre; Mr. Lewis, Lewis & Kuschel Co., of Pittston; P. C. Peuser, the P. C. Peuser Store, of Scranton; William Chal-

lenger and Robert Owen, the Challenger Store, of Nanticoke; R. W. Yohn, Oliver Yohn & Co., Danville; L. P. Maynard, D. S. Andrus & Co., Williamsport; Harry Seebold, Seebold Music House, Sunbury; M. Meiser and J. W. Lewis, Meiser's Music House, Northumberland; J. W. Maus, the J. W. Maus Store, Shamokin; W. E. Watkins, the W. E. Watkins Store, Mahanoy City; John M. Hough, the John M. Hough Store, Shenandoah; George W. Kellmer, the Kellmer Piano Co., Hazleton; James H. Powers, the Prince Furniture & Carpet Co., Hazleton, together with Miss Alta Robbins, Miss Clara G. Maguire, Miss Matilda Wardell, representing the same company; Nathan Gottlieb, the Nathan Gottlieb store, of Glen Lyon; Neal Connaghan and James Connaghan, Neal Connaghan store, of Mt. Carmel, and S. S. Lowry, prospective dealer from Berwick, Pa.

After the meeting the speakers were in session to answer any questions the dealers asked and they took advantage of the opportunity and gained some very useful knowledge. This meeting was preliminary to a larger meeting to be held in Philadelphia for all dealers of the Philadelphia branch in the near future.

### DEATH OF MRS. GEO. A. KELLEY

George A. Kelley, manager of the record ordering department of the New York Talking Machine Co., Victor wholesaler, is receiving the sympathy of his many friends in the trade upon the death of his wife, Mrs. Elizabeth Kelley, who died suddenly March 18 at her home in Rockville Centre, L. I. Mrs. Kelley, who was thirty-eight years of age at the time of her death, had a host of personal friends, among whom were the employes of the New York Talking Machine Co. She is survived by two children.

### YVONNE GALL HURT IN TAXI CRASH

Yvonne Gall, French prima donna and Pathé star, had a narrow escape from a serious accident in New York recently when a taxicab carrying her crashed head-on in Central Park with a machine driven by Otto Beeler.

The singer was taken in an ambulance to Flower Hospital, but left after an X-ray examination showed no bones broken. Both taxicabs were smashed. Beeler was arrested.

SEND FOR ILLUSTRATED PRICE LIST  
AND FREE SAMPLE

### "GLOBE" TRANSFER NAME PLATES

DEALERS EVERYWHERE APPLY THEM  
ON PHONOGRAPHS, PIANOS, ETC.

GLOBE DECALCOMANIE CO.  
JERSEY CITY, N. J.

### COTTON FLOCKS

.. FOR ..

Record Manufacturing

THE PECKHAM MFG. CO., 238 South Street  
NEWARK, N. J.

## Ward's Khaki Moving Covers

### Distributors

BRISTOL & BARBER, INC.  
111 E. 14th St., New York City

YAHN & LANGE DRUG CO.  
207-215 E. Water St., Milwaukee, Wis.

COHEN & HUGHES, INC.  
Washington, D. C.

BECKWITH-O'NEILL CO.  
Minneapolis, Minn.

STREVELL-PATERSON HARDWARE CO.  
Salt Lake City, Utah

OHIO SALES CO.  
Beckman Bldg., Cleveland, Ohio

THE REED CO.  
237 Fifth Avenue, Pittsburgh, Pa.

SONORA DISTRIBUTING CO. OF TEXAS  
Dallas, Texas.

CHAS. H. YATES  
311 Laughlin Bldg., Los Angeles, Cal.

W. D. & C. N. ANDREWS  
Buffalo, N. Y.

SACHS & CO.  
425 So. Wabash Ave., Chicago.



Grade "D" Cover with No. 3 Straps.

### THE C. E. WARD CO.

(Well-Known Lodge Regalia House)

101 William St., New London, Ohio

Also Manufacturers of Rubberized Covers  
and Dust Covers for the Wareroom





REG. U. S. PAT. OFF.

*The Standard by Which All  
Phonograph Motors are Judged and Valued*

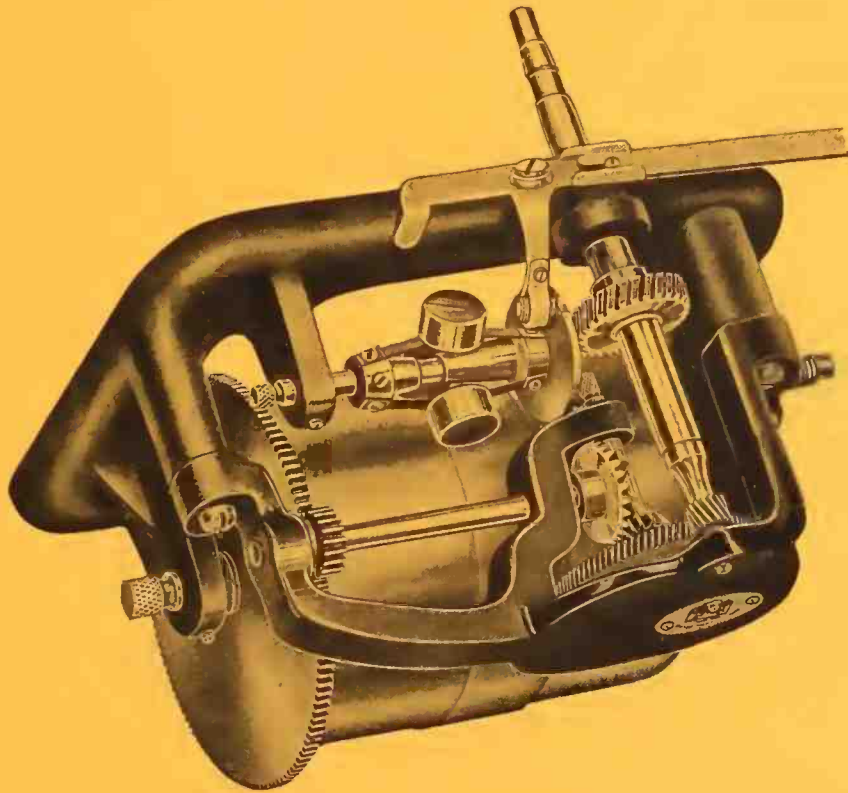

## *Strong Selling Features of The Sphinx Gramophone Motor*

Without its motor a phonograph is merely a piece of furniture. Therefore its strongest selling features should be *in the motor*, for it is the motor that makes the phonograph a musical instrument.

What is the strongest possible "talking point" in a motor? Obviously, the absolute *provable* elimination of those motor faults which make people hesitate about buying phonographs. What are those faults? Mechanical noises; the lack of uniformity in speed; the need of frequent adjustment, "tuning up" and repairs.

The Sphinx Motor absolutely *does* eliminate these motor faults, fully and finally, and has *proved* that fact by the most drastic tests to which a motor could possibly be put. The manufacturer who fails to see it, investigate it and *adopt* it, loses the opportunity to avail himself of the only *real* "talking points" a motor can offer him.

The Sphinx Motor is now in process of commercial manufacture and will shortly be ready for quantity delivery. Write for catalog describing and illustrating this motor in all its details.

**SPHINX GRAMOPHONE MOTORS, Inc.**

512 Fifth Avenue

••

••

••

••

New York







**NEW HOMES FOR COLUMBIA IN CINCINNATI AND DALLAS**

Cincinnati Branch Will Be Located in a Six-story Building at 317-321 East Eighth Street, and the Dallas Branch Will Occupy a Three-story Structure at 316-320 North Preston Street

The general sales department of the Columbia Graphophone Co., New York, announced this week that arrangements have been completed whereby the company's Cincinnati and Dallas branches will occupy new homes. These arrangements were pending for several months and were closed after Robert E. Rae, of the general sales department, made a careful investigation of the facilities afforded the branches in their new quarters.

The new home of the Cincinnati branch will be located at 317-321 East Eighth street, in the heart of the wholesale jobbing district of that city. The company will occupy a six story and basement building, having a total area of 35,000 square feet. This is three times the space now at the disposal of the branch in its present home, and E. F. Dawson, manager of the Cincinnati headquarters, is delighted with the accommodations which will be afforded his organization.

The new Cincinnati branch faces a proposed boulevard, and is ideally situated from an advertising viewpoint. Included in the equipment of the building will be the Columbia model shop, special Columbia steel racks for records and distinctive furnishings and fittings. In fact

every detail will be representative of the most modern ideas in wholesale talking machine equipment.

The Dallas branch will occupy a four-story building at 316-320 North Preston street, having a floor space of 23,200 square feet. This is three times the space afforded the company in its present home, and it is interesting to note that the new building is provided with ideal trackage facilities. Fred R. Erisman, manager of this branch, and his sales staff are enthusiastic regarding the many desirable features of the new building.

These important moves were made in order to afford the Cincinnati and Dallas branches of the Columbia Graphophone Co. an opportunity to develop the fast growing trade in their respective territories. The demand for Columbia products in all parts of the country has been far beyond expectations, and during the past year the great majority of Columbia branches in the leading trade centers have been obliged to seek new quarters in order to accommodate this trade. According to present plans the Cincinnati and Dallas branches will occupy their new homes during the month of May.

**A. J. CRAFTS CO. ACTIVITIES**

Recent Official Changes—Plant Very Busy—  
A. J. Crafts Returns From Southern Trip  
—Other News of General Trade Interest

RICHMOND, VA., April 1.—The regular monthly meeting of the board of directors of the A. J. Crafts Piano Co., manufacturers of the Crafts and Ludlow lines of talking machines was held on March 24. A quarterly dividend of 2 per cent. was declared payable on this date. The following officers were elected to fill vacancies: R. A. Garber, treasurer, to succeed A. E. Roeber, resigned; F. M. Wilson, secretary, to succeed Richard Riley, resigned. The Crafts factories are reported very busy and rapid progress is being made in the construction of the new plant. The general offices of the A. J. Crafts Co. have been moved to advantageous quarters on the second floor of the Commercial Building, in this city. These offices are nicely appointed and are laid out with efficiency in view.

A. J. Crafts, president of the company, has

returned from a Southern trip. He brought back with him a very satisfactory amount of orders and reports that he found trade conditions very good wherever he visited. He expressed much gratification at the steadily increasing demand for Crafts phonographs.

Theodore H. Bower, vice-president and district manager for North Carolina with headquarters at Raleigh, has taken up once more his accustomed duties and is recovering nicely from his serious illness of several weeks' duration.

**TO OPEN BRANCH IN WASHINGTON**

WASHINGTON, D. C., April 5.—A large and fully equipped branch store will be opened soon in this city by the Sport Mart, large Columbia dealers. The new branch will be located at Fourteenth street and New York avenue in the Bond Building.

One of the callers on the talking machine trade in Providence, R. I., recently was Eastern Representative Frye, of the Victor Talking Machine Co.

More than a fair proportion of the new Records are finding their way into

**Udell Cabinets**

because our Cabinets fill Every Need of the Record Owner.

MANY SIZES and DESIGNS  
PLUS  
PERFECT  
WORKMANSHIP



No. 1415  
[Horizontal Shelves]  
For Victrola IX-A

Height, 31 in. Width, 19 in. Depth, 22 in. Mahogany. Quartered Oak. Holds 5 Victor albums. Average weight, crated, 60 pounds. [If vertical interior is desired, order No. 415.] [When felt interior is wanted, order No. 415F.]

The Udell Works  
1205 W. Twenty-eighth St.  
Indianapolis :: Ind.

**IOWA DEALERS  
LOOK US OVER**

We are the Iowa Distributors of

**Vitanola Phonographs**

"THE PHONOGRAPH OF MARVELOUS TONE"

—AND—

**Story & Clark Pianos**

"MANUFACTURED SINCE 1857"

*We Are Equipped To Give You Service*

**E. H. JONES PIANO CO.**

DES MOINES

Shops Building

IOWA



# CRIPPEN'S



THIS double page advertisement shows for the first time my complete line of Crippen "Interpretone" Talking Machines.

I did not expect to be able to show these entire six styles before July first. But here they are, three months ahead of schedule, owing to the efficiency of our factory organization.

Style RR is the machine I began business with on January first.

This is the style with which I placed representations in every state in the union since the first of the year and with which I established over 70 representatives in Greater New York in two weeks' time.

To the best of my knowledge and belief, Style RR is the best individual machine in the talking machine world.

I claim that in size, character and finish of cabinet work, quality of tone and general all-round salability, it is not equaled in the market at within twenty-five (\$25) dollars of its value.

And I can prove this, to your absolute satisfaction, in the following way:



STYLE No. 3—Mahogany, Height, 45"; width, 19"; depth, 20". ADAM—Mahogany. Height, 45"; width, 20½"; depth, 21½". STYLE RR (revolving door)—Mahogany. Height, 45"; width, 20"; depth, 22".



# SEXTETTE

I will ship any reputable talking machine dealer in the United States a Style RR Crippen "Interpretone" (or any other of these six styles he prefers).

I will ship it by express at my expense for a ten-day comparative test. If after comparing it with any other talking machine he wishes, if after testing it with any and all makes of records he wishes, he does not readily see that mine is a better machine by twenty-five (\$25) dollars than any other talking machine he has ever seen, he may ship it back, also, at my expense.

If, on the other hand, he likes it and sees that it is the money maker that I claim it is, I will then lay our selling plans and other details before him.

**Write or wire, at once.** The longer you delay the longer you put off the opportunity for big and active money making.

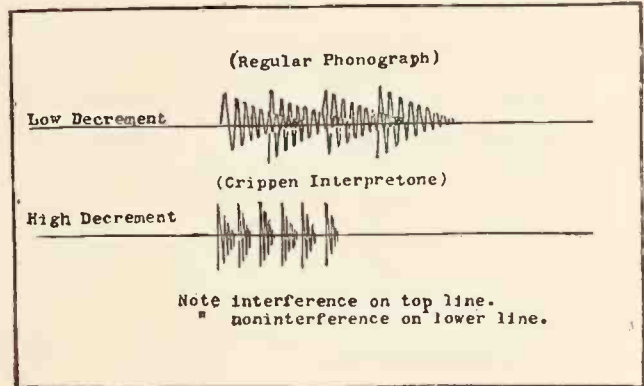
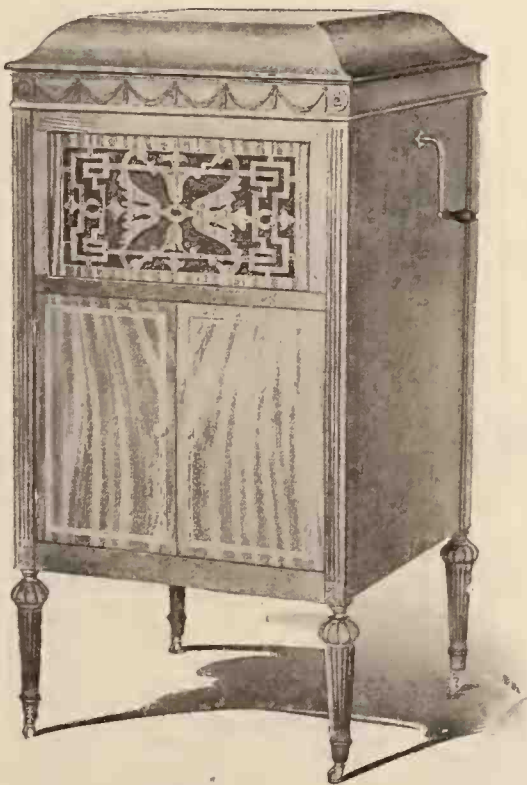

Diagram shows the difference between the sound waves coming from the talking machine as you know it and from the Crippen "Interpretone." In the latter the tail end of one tone does not collide with the front end of the succeeding tone. This results in clearer and more distinct reproduction.

**Metal work of all models heavily gold plated. Machines guaranteed for one year, which includes spring breakage.**

*Walter Crippen*  
President

THE CRIPPEN COMPANY, INC., 437 Fifth Avenue, New York



LOUIS XVI—Mahogany-Walnut. Height, 47"; width, 23½"; depth, 24½".



WILLIAM & MARY—Mahogany. Height, 49"; width, 23½"; depth, 24½".



QUEEN ANNE—Mahogany-Walnut. Height, 49"; width, 25¾"; depth, 26¾".





"Serenade" and "The Old Refrain," two violin solos by Eddy Brown, are good for steady sales for years. A-2882.

Columbia Graphophone Co. NEW YORK

TO BUILD PLANT IN NEW HAVEN, IND. STRIKING SERIES OF SONORA WINDOW AND CAR CARDS

Machines to Be Manufactured by Waggoner Talking Machine Co.—Work to Begin at Once

The advertising department of the Sonora and car cards interchangeably—an excellent idea. Phonograph Co. has just prepared a set of The new series consists of six attractive cards, window display cards about the same size as featuring Sonora product in a dignified, effec-

FORT WAYNE, IND., April 6.—The William A. Waggoner Talking Machine Co. has contracted for the building of a factory building at New Haven, Ind., which will begin at once. The factory building will be built of tile and will be but one story high, measuring 100x300 feet. The company will also build two standard dry kilns measuring 17x23 feet and a heating plant. The company will buy its lumber direct from the mills and it will be taken to New Haven where it will be dried in the dry kilns.

The ground on which the buildings will be built is just west of the Ohio Electric railway station at New Haven. The company has approximately six acres of ground. The location is ideal, the factory being situated on the Wabash, Nickel Plate and Ohio Electric railways and the Lincoln highway. The credit for locating the factory at New Haven is given to William Schnelker, of that place.

The directors of the company are Fort Wayne and New Haven men and are as follows: William A. Waggoner, John C. Waggoner, George Buechel, W. L. Henry, John R. Pulver, L. H. Zwick, of Fort Wayne and Herman Good-year, of New Haven.

INCREASES OUTPUT OF CABINETS

McHENRY, ILL., April 6.—The Everett Hunter Mfg. Co., of this city, has completed the remodeling of that part of its plant given over to the manufacture of talking machine cabinets and is now in a position greatly to increase its output.

This company has been for years manufacturing power boats and launches, and is known all over the world for its high-class products. The part of its plant wherein it carries on the business of making talking machines has been equipped with the most modern wood-working

machinery and the finishing rooms have more than trebled their capacity. This company has been manufacturing cabinets for some time now, and has now decided to go after this business on a larger scale. It furnishes cabinets in all woods and finishes, or in the white, and recently closed contracts to furnish cabinets for several well-known western companies.

Selection of Cards Which Are Favored by Sonora Dealers

the standard cards. These cards were prepared in accordance with the suggestion of Sonora dealers, who desire to use their window display

in a dignified, effective manner. The cards are multi-colored, and can be used to advantage in the windows of the dealers, and also as car cards.

WILL HANDLE VOCALION LINE

The Cunningham Piano Co., Scranton, Pa., has recently placed the Aeolian-Vocalion in its talking machine department. This is one of the thriving talking machine centers of the State of Pennsylvania, hence there is a large market for the Vocalion.



FOUNDED 1835



ARMSTRONG'S

Distributors

There are certain desirable localities still open for wide-awake Pathé dealers in the South.

Our Superior Service, co-operation and jobbing experience enable us to give all dealers the right start. A good start is half the game. Write today for full information.

ARMSTRONG FURNITURE CO. 59 and 61 North Main Street Memphis, Tenn.



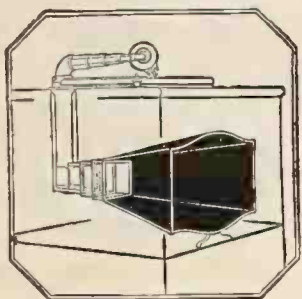

*The violin-shaped resonator of The Cheney creates true tonal beauty and adds rare quality to vocal or instrumental records.*

*To its exquisite beauty* of tone and distinct excellence of finish, The Cheney has added the third requisite to widespread appreciation. It is being presented to persons of musical discrimination by an extensive campaign of national advertising.

Paintings in oil are used to portray The Cheney in the appropriate environment of well appointed homes. Word pictures convey the fidelity of tonal reproduction achieved with The Cheney.

In consequence, dealers who stock The Cheney are enjoying an even more insistent demand for these wonderful instruments.

CHENEY TALKING MACHINE COMPANY - CHICAGO

# The CHENEY



# Demand for Better Furniture Stimulated by the Artistic Talking Machine Cabinets

The talking machine, which has long been recognized as a missionary for good music, is now beginning to shine in a new role as a missionary for good furniture. Almost from the start considerable attention has been given to the casing of the talking machine. Then, before the coming of the period models, the manufacturers clung to certain prescribed rules of artistic furniture design in the production of their cabinets. There was little or no attempt to produce simply the ornate, but rather an earnest endeavor to offer something considered elegant from its very simplicity. We may say that up to a couple of years ago there was little attempt at variety in talking machine cabinets, with several manufacturers clinging closely to standardized forms, but these forms, so far as the cabinet maker is concerned, were correct.

Now there are furniture manufacturers and dealers who are frequently inclined to admit that the placing in homes of the better classes of talking machines, with their richly finished and carefully designed cabinets, has stimulated a demand for better things in the general line of furniture, and it is natural that such should be the case. There are few talking machine dealers who have not had the experience of placing a machine valued at \$150, \$200 or \$250 in a room that even the most kindly critic would admit was poorly furnished. When installed in such a room the machine naturally looked out of place—painfully so—and it is now realized that many machine purchasers have through that fact been moved to refurbish their apartment to an extent at least that would prevent

the talking machine from appearing to be so glaringly out of place.

Then there is the influence of the talking machine design upon the taste of the home owner. There is, has been, and always will be a certain inartistic element who believe that richness means gaudiness—that much carving and gilt are necessary if art is to be repre-

## *Richness of Design and Finish of Talking Machines Arouses New Desires For Home Furnishings*

sented. Except in rare instances they have been unable to get this over-abundance of cheap carving, or gold leaf, in talking machine cabinets, and have thus been forced to accept models simple but really artistic in their design. The association with cabinet work of this type has naturally had its effect in many cases, a fact reflected in the demand for other furniture in keeping. Whether or not the placing of the richly finished talking machine in the home has resulted in the purchase of

new furniture, the fact remains that it has in many cases stimulated the desire for furniture of the better class—a desire that will be fulfilled at the first opportunity.

There is still a question as to just how far the newer period styles will serve to influence the selection of furniture of the period type, for it is to be assumed that in a great many cases period models are purchased to harmonize with established room furnishings. It is extremely unlikely that a customer would insist upon a machine of the William and Mary design, for instance, unless the machine was to be placed in an apartment where the furnishings of that period, or of a harmonizing period, were already in place. There are undoubtedly, however, numerous cases where a period model has been bought for its own attractiveness, and where it will inculcate in the new owner a desire for period furniture of a general nature to bring about at least a semblance of harmony.

Just as the talking machine brought into the mind of many average citizens a desire for the best in music, where before only popular airs were wanted, so may the same talking machine be credited with bringing into the home a desire for simple, artistic and harmonious furnishings where previously buying had been haphazard through lack of a guiding influence.

The Nostrand Phonograph Co., Brooklyn, N. Y., begins business with a capital of \$25,000 and the incorporators are: L. Wharton, M. Schenckman and S. M. Krasner.

# ANDREWS



Record Department

## VICTOR SERVICE

*A record department, constructed in accordance with the most modern ideas; so as to keep the records in excellent condition, yet make them accessible so as to fill orders immediately. Another part of*

*Andrews Victor Service*

**W. D. & C. N. ANDREWS - Buffalo, N. Y.**





# The Cardinal

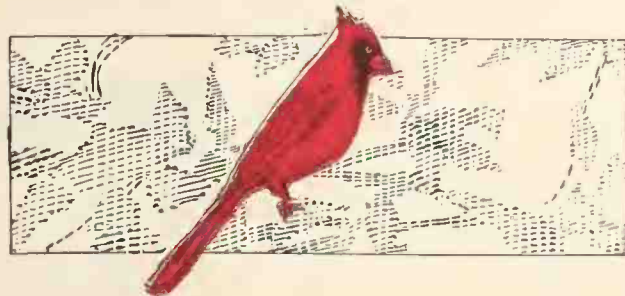

## The Cardinal

ARE you interested in doing a bigger, better-paying business? The Cardinal Phonograph offers you an exceptional sales possibility—one that you should investigate today. With this unusual instrument, prompt deliveries, a liberal sales policy and a complete dealers' service, there is a live opportunity for someone in your territory.

Real value is so obvious in Cardinal Phonographs that they always find ready sale wherever they are displayed. To a customer they immediately look like *more for his money*—they sound like better instruments than he thought such a price would buy. He *sees* the quality—hears it—and buys the Cardinal on the strength of it.

If you are looking for a strong, co-operative connection, take up the Cardinal agency. A card from you will bring detailed information of our proposition.

The Cardinal  
Phonograph Company

NEWARK, OHIO

*Factories at Zanesville, Ohio*



*The Manor Model—An excellent piece of cabinet work and an instrument of perfect reproduction*



### GALLI-CURCI REPLACES THE "BLUES"

Colored Woman Displays Quick Appreciation of Better Class of Music and Proves It by Buying Second Record When First Breaks

Mrs. Rose, wife of a Victor dealer at Jackson, Tenn., tells the following interesting story. One day an old colored woman came in whom Mrs. Rose knew quite well, and asked for some "Blues." Mrs. Rose happened to be out of the "Blues" asked for, and quite as a venture said: "Mary, why do you colored people get nothing but 'Blues'? Why don't you buy some good music?" The old woman looked at her and then said suddenly, "I hate 'Blues'." At the time a customer was playing Galli-Curci's "La Partida." The old woman pointed at the machine and asked "What's that piece?" Mrs. Rose told her. "I want that," said the woman. "But," said Mrs. Rose, "the piece is in Spanish. Are you sure you want it? I'm afraid you won't understand it." But the old woman insisted she wanted it and carried it off, the first Red Seal record she had ever bought.

Mrs. Rose thought she had bought the record merely from some sudden whim and dismissed the incident from her mind. But in a few days she was surprised to see the old Negress come in again. "Mrs. Rose," she said, "you know that piece I got Friday; well, my old man went and set on it and broke it, and I wants another just like it right now." And she bought her second copy of that Galli-Curci record and went off happy.

### TO MAKE KANAWHA PHONOGRAPHS

CHARLESTON, W. VA., April 6.—The T. & H. Specialty Mfg. Co., of this city, has taken over a building containing 30,000 square feet of floor space and will manufacture the "Kanawha" phonograph. The company expects to start the actual production of machines about June 1, and is now placing orders for a large supply of raw materials.

### \$13,000 PER BOOTH PER YEAR

This Gives a Partial Idea of the Great Talking Machine Business Done by Stix, Baer & Fuller —To Have Thirty-five Booths by July 1

A recent visitor to the executive offices of the Sonora Phonograph Co. was J. W. Medairy, of the talking machine department of Stix, Baer & Fuller, of St. Louis, who was most enthusiastic regarding the prospects for 1920, stat-



Stix, Baer & Fuller Sonora Display

ing that the business closed by Stix, Baer & Fuller during 1919 was limited only by the capacity of the building.

In the phonograph department they did a business of \$13,000 per booth per year and could have sold many more instruments had they been able to accommodate customers. It was no infrequent thing for the phonograph department to be jammed so full of people that the health department complained to the management and insisted that more room would have to be provided or the crowds thinned out. Customers waited patiently for several hours to hear favor-

ite records played and to have Sonoras demonstrated.

Mr. Medairy sprang a novelty on the people of St. Louis last year by securing two baby grands and one grand in what might be called a raw state—that is, in the white wood without varnish or polishing. These unfinished instruments were artistically arranged in a window with a Sonora motor and a Sonora semi-permanent needle display, the whole window being artistically draped with dark purple velvets, and there was a continual crowd before this display.

The large business done by the phonograph department has caused the management to decide to have thirty-five booths in place by July 1. This new department is expected to be the handsomest West of Chicago and will use bronze as the color motive. Solid mahogany booths will be erected with double panels, having air space between, making the booths not only convenient, but sound-proof, handsome and efficient.

### PROBLEM OF SECURING A JOB

"Selling Your Service" is the title of a new book which has recently made its appearance on the market, and several paragraphs of which have been written by a well-known talking machine man. The book, published by Jordan-Goodwin Co., New York, covers a series of lectures and constitutes a comprehensive treatment in all its phases of the problem of securing a job.

Progressive and successful sales methods in merchandising are clearly shown to be immediately and effectively applicable in selling one's services and in the simple and logical development of a sales campaign for that purpose a great variety of new ideas and angles in the job seeker's problem are presented. Many model and successful letters of application, advertisements, follow-ups, etc., are reproduced, and the book as a whole well merits the praise which it has received from students of economics.

**T**HE unquestioned acceptance accorded the MARVELON PHONOGRAPH in the past three years is indicated by the fact that in the face of ever increasing production we have, until recently, been unable to keep pace with the demand to establish new agencies for the Marvelon.

Grateful as we are for this recognition, we hold more precious the necessity of preserving the standard that has made our success possible.

Having again increased our production, we are in a position to care for the requirements of a limited number of new dealers —dealers who are able to sell a quality Phonograph.

Such dealers will find it to their interest to correspond with an organization that is inspired by an ideal in the producing and marketing of its product.

**Marvelon Phonograph Co.**  
508-510 Arcade Bldg.  
St. Louis



# Another *Tonofone* Message

## At Last the Secret is Out! People Now Know That the Weak Spot in Every Phonograph is the Needle!

G. C. KENNEDY, PRESIDENT      P. G. CLEGGAN, SECRETARY      G. C. HOLMES, VICE-PRESIDENT  
3084 16TH AVENUE, HEMMETT 2328



**GLENVIEW IMPROVEMENT CLUB**  
THE RESIDENTIAL DISTRICT SURROUNDED BY PARKS  
**OAKLAND, CALIFORNIA**

March 22, 1919.

R. C. Wade Co,  
Chicago, Illinois.

Gentlemen:-

Kindly mail me five packages of "Tonofone" needles, for which I enclose fifty cents in postage stamps. I have tried out various makes of so-called semi-permanent needles, including the much advertised "Needles", but have found nothing that in any way can compare with the "Tonofone" samples received from you a short time ago through your advertisement in the Talking Machine World. You simply cannot boast the "Tonofone" needle enough.

It takes only a trial to convince one of this. Kindly advise me by whom the Tonofone is carried in stock in either San Francisco or Oakland, Calif. If you are not represented by a jobber in this locality, may I take the liberty to suggest your taking up the matter with Mr. Walter S. Gray, Jobber of Talking Machine Accessories, Chronicle Bldg., San Francisco? I do not wish to appear presumptuous, but would like to see your product on sale in every phonograph store in the country, that is how much I think of it.

Yours truly,  
*P. G. Cleggman*

Tonofone is positively the best needle made. We don't think it—we know it. We're not arguing—we're telling You. But it isn't what we think or You think — it's what others think that counts, and counts big. It's their trade and their money that keeps business going — if we don't satisfy them— **Good Night!**

PETER H. RIPKE  
CHIEF OF POLICE  

**OAK PARK, ILLINOIS**  
DEPARTMENT OF POLICE

CHIEF'S OFFICE  

January 17, 1920.

The R. C. Wade Co.,  
110 S. Wabash Ave.,  
Chicago, Ill.

Gentlemen:-

Please accept my sincere appreciation for the wonderful Phonograph needle you have produced, and which is now selling on the market under name of "TONOFONE".

I am the owner of a cabinet size Victrola and have close to 500 records in my collection. I have tried every needle on the market, and have had more or less satisfaction, according to length of time a certain needle was used. I recently noticed your Ad in one of Chicago's local news papers, and immediately purchased a package of your needles, and to my great delight, I had new born music, yes music I never knew existed in any phonograph record, and without the usual scratching.

Therefore, Gentlemen, allow me to congratulate you, upon your wonderful achievement, in producing this NEW BORN MASTER OF PHONOGRAPH NEEDLES, for the music loving public.

Very truly yours,  
*T. Lindhe*  
Sergt., of Police.

Thure Lindhe  
210 Marion St.,  
Oak Park, Ill.

**Tonofone Satisfies** where other Needles disappoint—makes Music where others just make a scratchy somewhat musical noise.

**Stock up on Tonofone** — use its Superior qualities for demonstrating. It sells records and machines.

**Our Advertising** is distinctive and different—it is honest—it commands attention—it gets business for you.

### Our Wholesale Distributors Cover the Earth They Reach Every City, Town and Hamlet All Over the World

EASTERN AND EXPORT REPRESENTATIVES  
**EMERSON INTERNATIONAL, INC.**  
 1780 BROADWAY, at 57th STREET  
 NEW YORK CITY  
 PHONE, CIRCLE 3822

**DON'T LOSE TIME**  
 WRITE FOR FULL PARTICULARS  
 AND NAME OF NEAREST  
 DISTRIBUTOR  
 TODAY

INVENTORS AND SOLE MANUFACTURERS  
**R. C. WADE CO.**  
 110 SOUTH WABASH AVENUE  
**CHICAGO**  
 PHONE RANDOLPH 2045



# H.K. Lorentzen

Manufacturer of  
**Exclusive Cabinet Hardware and Accessories**  
60 Grand Street  
New York City

### COST OF SHELLAC RISES 1,212%

Imports Into Great Britain in January 1920 Only One-half Those of Same Month in 1913 but Value Increases Over Twelve Times

Some idea of the soaring cost of shellac in the last few years may be obtained from a study of the import statistics of Great Britain for the years from 1913 to 1920. In January, 1913, 1,280,000 pounds of shellac were imported into the United Kingdom. This shellac was valued at \$42,007, or about three and one-third cents a pound. In January, 1920, only 670,000 pounds were imported, practically one-half of the amount imported in the same month in 1913. This 670,000 pounds, however, was valued at \$254,010, making the price of each pound about forty cents. From these figures it may be seen that shellac rose approximately 1,212 per cent in that time.

### VICTROLA AIDS IN ORGAN RECITAL

A Victor XVI Electric has recently been used with very satisfactory results in conjunction with a series of organ recitals held in the Evansville, Ind., Coliseum, the Victrola being furnished by C. A. Phelan, of the R. & G. Furniture Co., Evansville. The organ recitals are held weekly and invariably attract large audiences.

R. and E. Michnoff and H. S. Dreyer, 9400 Lafayette avenue, Brooklyn, N. Y., have incorporated the Michnoff Talking Machine Co., which has a capital stock of \$25,000.

### INTRODUCE NEW NEEDLE REST

Product of Acme Engineering & Mfg. Co. Contains Several Important Improvements

The Acme Engineering & Mfg. Co., Chicago, Ill., has just placed on the market a new needle rest which is being adopted by many of the leading talking machine manufacturers. This needle rest is more attractive than the old type, as it eliminates the old model cup and felt pad.



Needle Rest

In addition to its attractiveness this needle rest has won favor because it has the fastening stud incorporated and saves the nail—a blow with a hammer secures it in place on the motor board. It is furnished with felt to match the trim of the cabinet or the regulation green.

### MAKES A HIT WITH SCOTCHMEN

Abe H. Williams, of Williams' Music House Birmingham, Ala., recently assisted in making the program of the local Civitan Club a very enjoyable one. The occasion was termed "Scotchman's Day," and Mr. Williams immediately got busy and sent a Victrola XVII and five of the best of Harry Lauder's records to the clubroom. While the members were busily engaged in eating he slipped on a Harry Lauder record. Naturally, everybody was surprised and left the meeting with a better idea of just what the Victrola was capable of doing. Very naturally, Mr. Williams was able to cash in on Harry Lauder's records later.

### FLEET OF SONORA MOTOR TRUCKS

The transportation department of the Sonora Phonograph Co. recently made arrangements whereby it will secure a new fleet of motor



First of Sonora Co.'s New Fleet trucks. The first one of these trucks is shown herewith, and additional trucks are now on order. The truck shown in the illustration is a three-ton Mack and will carry at least forty Sonora phonographs.



## Okeh Records



We have the latest new records all ready for your approval. Come in and hear them and let us demonstrate their superior quality.

### Send Your Orders Now for TWO OKEH SPECIALS

Get them while they have the Best Selling Value

4079 { I'll See You in C-u-b-a  
(Tenor) with Rega Orchestra - - BILLY MURRAY  
Dardanella  
(Tenor) with Rega Orchestra - - BILLY MURRAY

4080 { My Isle of Golden Dreams  
(Waltz) - - - - - JOE THOMAS SAX-O-TETTE  
In and Out  
(One-Step) - - - - - JOE THOMAS SAX-O-TETTE

## The Steinola Company, Inc.

1113 WALNUT STREET

KANSAS CITY, MO.



NO PHONOGRAPH  
COMPLETE  
WITHOUT IT

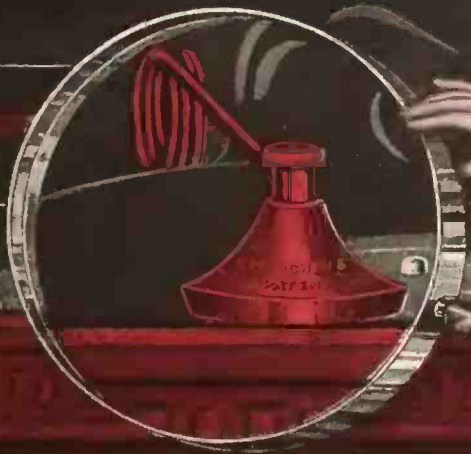

*Invented by JOSEPH MENCHEN inventor  
and patentee of the first liquid fire  
appliances used by the Allied armies*

## VACUUM RECORD LIFTER

THE FIRST RECORD LIFTER ON THE MARKET

IT RAISES THE RECORD WITHOUT TOUCHING  
THE TONE ARM · IT PREVENTS SCRATCHING  
THE RECORD · AVOIDS SOILING YOUR FINGER  
NAILS · NOTHING TO GET OUT OF ORDER,  
NEVER WEARS OUT · CAN BE ATTACHED TO  
ANY MACHINE WITHOUT THE USE OF TOOLS.

*Its a 1919 Master Patent!*

**DIRECTIONS :**

Press your finger downward on the lifter until the cup  
grips the record, place other hand beneath the record,  
remove finger slowly from the vent and record is released.

*Price: Nickel plated \$2.50 complete. Gold plated \$3.50*

To obtain more detailed infor-  
mation concerning the Record  
Lifter write your jobber—or  
better still, write directly to us.



VACUUM RECORD LIFTER Ltd.  
701 SEVENTH AVENUE, NEW YORK CITY, U.S.A.

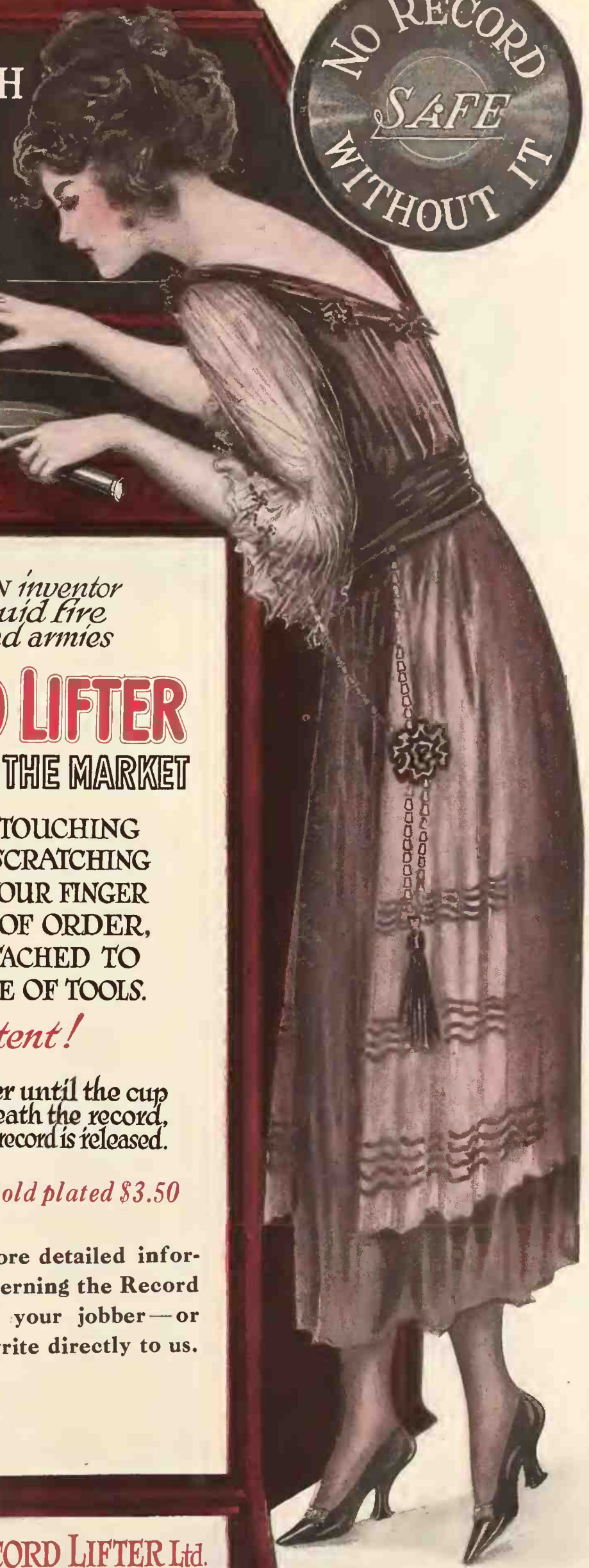





## Investigate this: it is worth while

**B**Y the use of the reed cabinet, the Heywood-Wakefield Phonograph is made free of those discordant vibrations of sound which take place in the closed-in, sealed-up air spaces of a wood cabinet. The music flows through the open spaces of the reed without any vibratory interference, thus retaining its purity and fullness of tone.

The Heywood-Wakefield "cushioned" reproducer has been built with scientific exactness to parallel the human organs of sound. It is absolutely non-resonant. No detail of a record, no matter how delicate, escapes the reproducer—and there is no "screech" to mar it.

There is moreover an added appeal in the Heywood-Wakefield. The cabinet can be had in three hundred different shades of color, and possesses the distinct selling-feature of harmonizing with every style of wood furniture, as

well as fitting in happily with the growing demand for reed and wood combinations, or reed alone.

It is equipped with electric or spring motor. For those who prefer an electrically driven instrument, the dealer will find the Heywood-Wakefield motor alone making many a sale. It is a universal motor, never heats, is silent in operation and uniform in speed.

The purity of tone obtained through the reed cabinet and the non-resonant reproducer—the decorative value of reed work—and the perfected electric motor, make this instrument, from a practical sales angle, a valuable addition to every dealer's line.

The Heywood-Wakefield is made under the Perfek'tone patents.

Write today for details of models, prices and specifications. Address the nearest office of

### HEYWOOD BROTHERS & WAKEFIELD COMPANY

New York Philadelphia Boston Baltimore Buffalo Chicago Portland, Ore. San Francisco Los Angeles

Factories: Gardner, Mass.; Chicago; Wakefield, Mass.

When you visit Atlantic City see all models of the Heywood-Wakefield at the Perfek'tone Store, 517 Boardwalk

*The Heywood-Wakefield*



## OPTIMISM REIGNS SUPREME IN SAN FRANCISCO TRADE

Welcome Rains Help Agricultural Prospects—Stock Conditions Steadily Improving—Demand Continues for High-grade Machines and Records—Phonograph Studio Holds Formal Opening

SAN FRANCISCO, CAL., April 4.—A decided toning up of business in all branches of the music trade is noticeable this month. The rains, coming after an unusual Winter drought, have restored confidence in the never-failing California climate and those who recently essayed the role of pessimist have retired to the rear. The stock situation has greatly improved in San Francisco, yet standard goods are still short in many lines. High-class records sold exceptionally well during the month by reason of the many concerts given in the city by noted record artists. Violin records, especially, scored heavily. The demand for Heifetz records is greatest in the instrumental line, "Dardanella" shows no signs of waning popularity and the new jazzy stuff is certainly "getting by."

### Dealers of Bay Cities Hold Dinner

The talking machine dealers of the San Francisco Bay district assembled at a rousing dinner at the "States" café on the evening of March 30 and discussed many problems of the trade. Billy Morton, chairman of the entertainment committee, was pleased that so many representatives of the talking machine establishment in the Bay cities attended the dinner. Covers were laid for fifty-two guests.

### Conducts Successful Victor Shop

A. G. Prouty, the well-known dealer of Napa, frequently visits the trade in San Francisco. On a recent visit here he commented on the success he is enjoying in conducting an exclusive Victor shop. Even in the smaller communities, he believes, it is profitable to have at least one exclusive establishment.

### Kane Causes a Sensation

Fame and success are often purely accidental, but in the case of Robert E. Kane of the traveling force of the wholesale Victor department of Sherman, Clay & Co., both these coveted prizes are the direct result of genius. Mr. Kane is known from one end of his territory to the other as the Beau Brummel of the trade and the dealers bow to his dictum in all matters sartorial. His latest sensation is a pint-and-a-half derby.

### Blue Bird Ambassador in City

Fred L. Christianer, sales manager for the Blue Bird Talking Machine Co. of Los Angeles, is in San Francisco for a week or two, and he announces that the new machines which will shortly be ready for distribution will embody several important improvements that will greatly interest the trade. A new traveler for this company is Marshall Breeden, who will cover the Southwest territory.

### A Policy That Is Winning Out

James L. Loder, manager of the Sonora Phonograph Shop, says the policy of not exchanging or sending records on approval is a real business getter. Since this idea was introduced at the Sonora shop three months ago

he has had a number of customers express delight that now they are absolutely assured of obtaining unused records when they make purchases. The shop, of course, guarantees the perfection of each record sent out.

The sales force of the Sonora Phonograph were entertained at a theatre party and supper on March 22 by Mr. Schumway, manager of the Western Jobbing & Trading Co., distributors of Emerson records.

### Manager Gruen Convalescent

L. Gruen, manager of the Pacific Coast office of the General Phonograph Corp., has been on the sick list lately, but is now pulling himself into shape again. He reports a most encouraging opening demand for the new motor which has just arrived at the San Francisco office.

Joseph M. Abrams, manager of the talking machine department and wholesale record department of Kohler & Chase, is supplied with the full Okeh catalog and in a position to make prompt deliveries on all orders. He says the new record, "Fast Asleep in Poppyland," promises to make a big success on the Coast.

### Celebrate Seventieth Anniversary

Kohler & Chase are celebrating the seventieth anniversary of the firm, which was established in 1850, by an introductory offer on Amphona talking machines. With the purchase of every machine the customer is given free twelve dollars' worth of records and a thousand needles.

### Talking Machine Business Grows

Since moving to the new store on O'Farrell street, the Hauschildt Music Co. has had a 50 per cent. increase in its talking machine business, notwithstanding the chaotic condition of the store. The alterations are about finished now and business can be transacted with more convenience and comfort. Mr. La Roche, the new manager, is developing policies of harmony and co-operation in the sales and mechanical departments and the results already show a big improvement over former conditions.

### Formal Opening of Phonograph Studio

The Phonograph Studio on Powell and O'Farrell streets held its formal opening on March 12 and business ever since has been very good. This shop is located on what is termed by the manager, William Quarg, "seventeen-hour-a-day corner" and accordingly the concern operates two shifts in the sales force. The shop keeps open until 11 o'clock at night. A booth for the sale of theatre tickets is located just inside the O'Farrell street entrance.

### Talking Machine Department Redecorated

The San Francisco talking machine department of the Wiley B. Allen Co. has been partly redecorated this month and the department in the Los Angeles store is about to be greatly enlarged by the addition of eight more record demonstration rooms. To provide for the needed extra space the company has had to

Well Rated Dealers  
Can Discount Their

## PHONOGRAPH INSTALLMENT CONTRACTS

WITH US

Thereby Turning Their Accounts  
INTO WORKING CAPITAL



take over floor area which has been occupied by the Lindsay Music Co. for ten years. This concern handles sheet music and small goods.

### To Increase Capital Stock

The Mercantile Finance Co. of San Francisco, of which Frederick Stern is president, held a stockholders' meeting on March 9 and at that meeting it was voted to increase the company's capitalization from one million to ten million dollars and to issue nine million additional shares of stock.

### Walter S. Gray Co. Increases Capital

The Walter S. Gray Co. has been authorized to issue \$200,000 worth of stock, preferred and common.

### Columbia Brieflets

Miss Estelle L. Windhorst, who is an educational specialist with the Columbia Graphophone Co., is visiting the San Francisco office. She is active in promoting the use of Columbia goods in the schools.

W. C. Henry, who has long been a member of the Coast staff of the Columbia Co., has retired to "private" life and will devote his great store of energy to developing his ranch in southern California.

### B. R. Forster Visits Walter S. Gray

B. R. Forster, president of the Brilliantone Steel Needle Co., was a visitor to the Walter S. Gray Co., his local agency, during the month, and from here he went to Los Angeles.

## VICTROLA BACK FROM THE WAR

The Victrola which wiled away many a long hour for the members of Base Hospital 57 during their stay in Paris is back where it started from—the store of George J. Veach, Oil City, Pa. The instrument, which was presented to the men who made up that unit when they left Oil City on May 29, 1918, by George Veach, was placed on display in one of the Veach show windows on Seneca street. It will be returned to the men as soon as it is taken out of the window.

Mr. Victor Dealer:—

Have your apparent profits on the sale of other lines been misleading?

If so, prepare for the future and future profits by tying up to "Victor Exclusively"



THE TOLEDO TALKING MACHINE CO.

VICTOR WHOLESALE

TOLEDO, OHIO





# UNITED

## Phonograph Motors

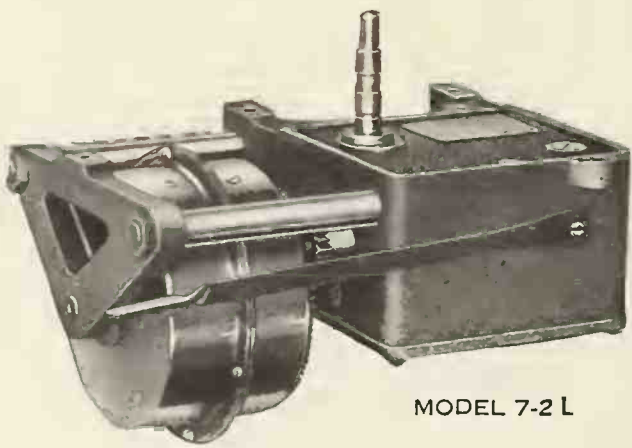

MODEL 7-2 L

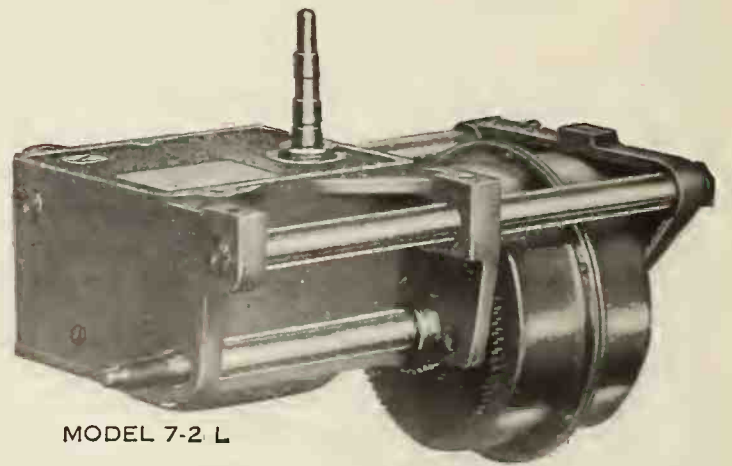

MODEL 7-2 L

### Compact—Silent—Self-Lubricating—Enclosed

The design of this new UNITED product makes a big step toward perfection in Phonograph manufacture. In this motor we have eliminated noise and have insured against trouble not only in the design but by the self-lubricating feature which all Engineers admit is essential.

Our production on this motor will be very large this year and we can assure phonograph manufacturers of a dependable source of supply—a silent, high quality, guaranteed motor which will do away with most of the present motor troubles. We have been big manufacturers of standard open type motors and the quality of our product is an indication of what may be expected in the way of mechanical perfection in this new motor.

Correspondence from interested manufacturers is invited.

SALES DEPARTMENT

**UNITED MANUFACTURING & DISTRIBUTING Co.**  
LAKE SHORE DRIVE AND OHIO ST. CHICAGO, ILL.



## COLUMBIA TO OPEN IN OMAHA

Columbia Graphophone Co. to Open Wholesale Distributing Branch in Omaha—Schmoller & Mueller, Former Wholesale Distributors, to Concentrate Activities Along Retail Lines

The general sales department of the Columbia Graphophone Co. announced last week that arrangements have been consummated whereby the company will open a wholesale distributing branch in Omaha, Neb. The location of the new branch has practically been decided upon and full details regarding the executive personnel, etc., will be announced in the very near future.

The Schmoller & Mueller Piano Co., of Omaha, Neb., was formerly the wholesale distributor for Columbia products in Omaha territory, but subsequent to this company's fire a few weeks ago the officers decided to concentrate their activities upon their retail business, paying particular attention to the development of their extensive piano interests. The company will handle the Columbia line at retail in a very large way.

According to present plans, the Omaha branch of the Columbia Graphophone Co. will be housed in one of the most modern and up-to-date wholesale establishments in the country. One of the features of the Omaha branch will be the installation of a model shop. Robert Rae, of the general sales department, who spent three weeks in Omaha investigating every angle of the situation carefully, visited the Columbia dealers in the Omaha district and assured them that nothing would be left undone to co-operate with them in every possible way.

For the present all Columbia dealers in the Omaha district are being served from the Kansas City branch. Several travelers have already left Kansas City to concentrate their activities in the Omaha territory and a foundation is now being laid for an efficient sales organization at the Omaha branch. In addition to Columbia Grafonolas and Columbia records the Dictaphone will also have its home in the new Omaha branch.

## "THE PHONOGRAPH WITH A SECRET"

This Slogan Is Being Featured by The Music Table Co. to Advantage—Business Active

GREENFIELD, O., April 2.—A steadily growing business and big demand for the Waddell phonograph are reported by The Music Table Co., manufacturers of this line. The ingenious slogan adopted by this company, "The Phonograph With a Secret," is becoming quite popular and is proving a real asset to the business. The company reports that increased capacity of manufacturing is being given more attention than the sale of their product, which seems to be taking care of itself.

## A NEW USE FOR BROKEN RECORDS

In Augusta, Ga., a use has been found for broken phonograph records. At least it would seem so, or perhaps it was merely an advertising venture, when the Criterion Theatre of Atlanta, one of the finest motion picture playhouses in the South, advertised that every broken phonograph record would be accepted at the box office one day recently for admission to the theatre. "Don't throw away your broken melodies," the theatre's advertising stated. "Don't pitch them out the window into the garbage can. If baby breaks your favorite Caruso, save it because it is valuable."

## TAKES STARR AGENCY IN ST. LOUIS

St. Louis, Mo., April 7.—The Connorized Music Co. has secured the local jobbing agency for the Starr talking machines, manufactured by the Starr Piano Co., of Richmond, Ind. These instruments were formerly handled by the Thiebes Piano Co., but for some time past have not been represented to any large extent in this city.

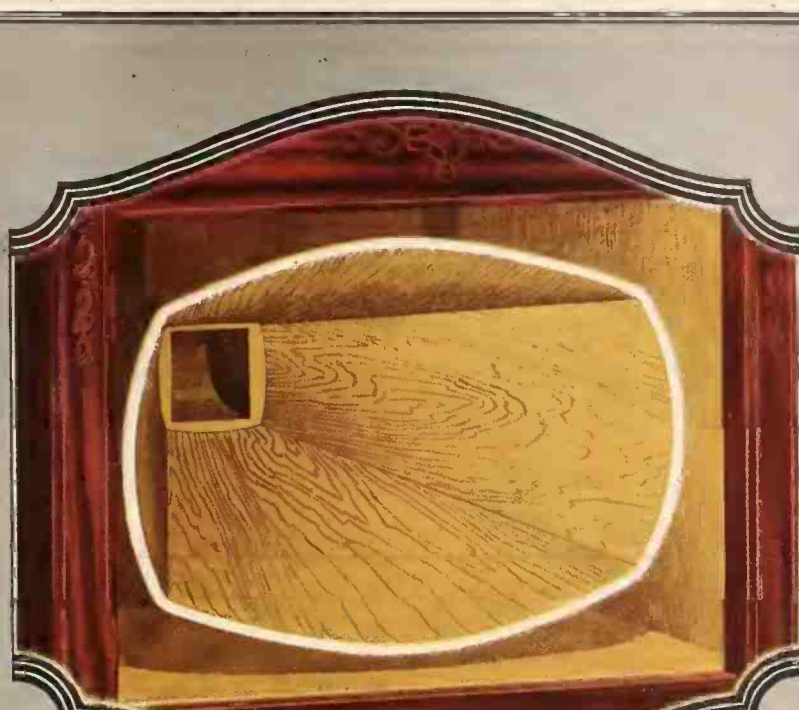

# HARPONOLA

Harponola's Golden Horn  
Holds a Golden Opportunity  
For You

HARPONOLA dealers have come to realize that the right to sell the "Phonograph with the Golden Voice" is a valuable franchise.

They have found that customers thrill with approval when Harponola's grille is removed and its beautiful horn of golden spruce is brought to view.

This golden horn is the heart of Harponola's sweetness. For the rich, well-seasoned spruce of which the horn is built is the one wood that responds most perfectly to tone vibrations.

Quite naturally, the machine that possesses a feature of such unquestioned superiority is likewise mechanically perfect. It plays all records. Has automatic stop and plush turn-table. Cabinets are built by the Mersman Brandts Brothers in a separate factory.

Write for further information. Also for details of our jobbing arrangements on the well-known OKeh records.

**THE HARPONOLA CO.**

EDMUND BRANDTS, President  
CELINA, OHIO

The  
PHONOGRAPH  
with the  
**GOLDEN  
VOICE**





## NEW ENGLISH CORPORATION

General Phonograph Corp., Ltd., Organized With Headquarters in London—A. J. Balcombe Appointed General Manager

Coincident with the recent visit of A. J. Balcombe, general manager of the Great Britain interests of the General Phonograph Corp., Otto Heineman, president of the corporation, announced the formation of a new company, which will be known as the General Phonograph Corp., Limited, with headquarters in London. The new corporation will be in charge of the Great Britain interests of the General Phonograph Corp. and A. J. Balcombe will be general manager.

Mr. Balcombe is one of the veterans of the talking machine industry, having been associated with the trade for over twenty-five years. He is thoroughly conversant with every phase of the field and has a host of friends abroad who will undoubtedly co-operate with him to excellent advantage in developing a demand for the General Phonograph Corp.'s products. Mr. Balcombe, who returned to England recently on



A. J. Balcombe

the "Baltic," commented upon the enthusiastic reception being accorded the motors, tone arms and sound boxes manufactured by the General Phonograph Corp. He stated that the outlook for the talking machine industry in Great Britain gives every reason for optimism, as the talking machine manufacturers throughout England are planning for a healthy future business.

The Mica Import & Export Corp. has been formed in New York by C. Kenney, S. Collora and M. C. Faraci, 475 West street.

## A TONE ARM OF QUALITY FEATURES

The Universal Tone Arm we offer manufacturers provides a distinctive sales advantage for their campaign because our tone arm is distinctive and possesses, aside from an attractive appearance, numerous unique and genuine sales-promoting features.



Patent Applied For  
Presto Universal All-Brass  
Ballbearing Base Tone Arm No. 11

The all-brass construction insures supreme tone qualities; a patented ball-bearing base provides the ideal record trackage; the non-blasting, superbly constructed reproducer has a perfected universal adjustment for playing all makes of disc records.

The result is a tone reproduction of quality and volume which cannot be surpassed. Why not investigate these distinctive features and have an arm that is different and better?

## Presto Phono Parts Corporation

124-132 Pearl Street

BROOKLYN, N. Y.

## TELLS OF BUSINESS PROGRESS

Harvey L. Morse Reports Great Activity in Newburgh, N. Y., and Gives Reasons

Harvey L. Morse, of the Columbia Music Store, Newburgh, N. Y., was a recent visitor to New York, calling at the executive offices of the Sonora Phonograph Co., where he gave an interesting account of the progress achieved by the Sonora phonograph in this territory.

"It's an actual fact," said Mr. Morse, "that every Sonora we sell means a sale of at least two or three more. This instrument in itself is the best possible salesman anybody can want. Our store is only one story high, and as we liked the Sonora twenty-four sheet poster we put a signboard right over our store and had a billposter put up this attractive advertisement.

"One of our townspeople saw the sign going up and came in to see us. He said that he was thinking of buying a Sonora but didn't know that we handled this instrument. He looked over our stock, bought a fine model and had it sent up to his home. This happened the first day the sign was up. We have since that time sold four other Sonoras to members of his family who admired the instrument which he had secured from us.

"We notice that there is an increasing demand for period models and have already sold several. Although our store is a little one, it is in a good location and it is not unusual for us to make as

many as 350 sales on a Saturday in our various music departments."

As may be seen from the accompanying photo-

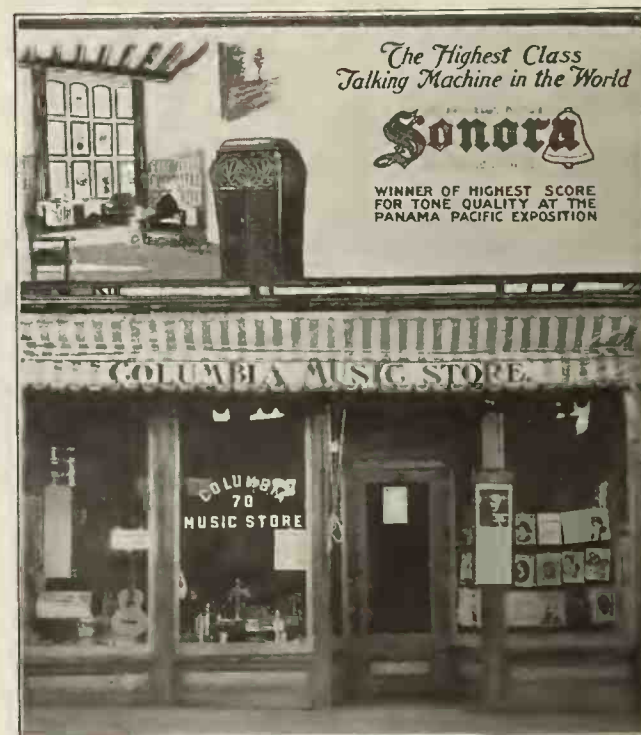

How Columbia Music Store Features Sonora graph, this large sign affords an excellent opportunity to convey to the public the message of Music and is a distinct asset to the dealer.

## Deliveries from Stock of High-Grade Low-Priced Table Machines

THE GREATEST VALUES ON THE MARKET



WONDER No. 15

WONDER No. 15—All metal machine, splendid tone quality, cast iron cabinet and cast iron frame motor. *Universal* tone-arm playing all records.

WONDER No. 23—Highly polished mahogany finished cabinet, all cast iron frame, *worm gear* motor. High-grade *Universal* tone-arm.

Priced from \$4.20 up

Write for catalog and dealer's proposition



WONDER No. 23

WONDER TALKING MACHINE CO., Inc., 109 East 12th St., New York





## Window Display Service for Eighth Bulletin

# Okeh Records

TWO DOLLARS MONTHLY

The new Okeh Window Display Service is meeting with great success. Okeh dealers tell us it is the brightest and liveliest bit of service they have ever used. A group of the best artists in New York is always at work devising new ideas and new art treatment.

The subject of window decoration and display is not new. Every dealer knows that a clean, attractive window draws business. This new service will sell more Okeh records, at the

same time solving your problem of window decorating. Each display will be in several colors and so designed as to fit into any size window. Easy to set up—easy to “read.”

**YOUR WINDOW IS 80% OF YOUR RENT. IT IS EASILY WORTH \$2.00 MONTHLY TO MAKE IT THE LIVELIEST WINDOW IN YOUR NEIGHBORHOOD. TELL YOUR DISTRIBUTOR SO — T O - D A Y.**

NOTE:—The photo shows the Eighth Bulletin Okeh Window Display now ready

## GENERAL PHONOGRAPH CORPORATION

25 West 45th Street

OTTO HEINEMAN, President

New York City, N. Y.

FACTORIES: Newark, N. J. Elyria, Ohio Putnam, Conn. Springfield, Mass. Kitchener, Ont.

BRANCHES: Chicago, Ill. San Francisco, Cal. Toronto, Can.







**MICA DIAPHRAGMS**

*Absolutely Guaranteed Perfect*  
We get the best India Mica directly.  
We supply the largest Phonograph Manufacturers.  
Ask for our quotations and samples before placing your order.

**American Mica Works**  
47 West St. New York

**MOTOR WOULD RUN FOR 2500 YEARS**

Machine Started in November, 1916, Runs for Eighteen Months Continuously

The Electrical Experimenter tells of the invention of a new type of talking machine motor by a New England man. This invention is the outcome of many years of experimentation. Gears have been eliminated entirely, the drive being transmitted from the electric motor at the left of an endless belt to the governor and friction rolls. Provision is made for adjusting the belt, for keeping the friction wheels in contact automatically, and for supplying the bearings with oil from saturated cushions.

One of these machines was started on a continuous-running test November 16, 1916, and ran continuously for eighteen months. At the end of this time it was operating quietly and perfectly in every way.

During this time the turn-table made over 64,000,000 revolutions, or enough to roll more than around the earth. The electric motor made over 1,475,000,000 revolutions. Allowing that the average phonograph is run one hour per week, this machine, at that rate, would (bar accident) have lasted its owner and his descendants over 2,500 years!

**INSTALLS ADDITIONAL BOOTHS**

The United Talking Machine Co., 19 Main street, Brockton, Mass., has again been forced to increase its facilities through the installation of five additional demonstrating booths, making fourteen booths in all now in operation. The company deals in talking machines and records exclusively and handles the Victor, Columbia, Edison and Sonora lines.

**Why Break Records?  
Just File Them!**

That is if you have the wonderful Record filing system which is a feature of

**The Marvelous MAGNOLA**



Watching the Music Come Out

This is only one feature of many that will command your interest and attention. Let us send you handsome illustrated catalog and information as to our plans for helping you to make money with MAGNOLA.

**MAGNOLA TALKING MACHINE COMPANY**  
OTTO SCHULZ, President  
General Offices Southern Wholesale Branch  
711 MILWAUKEE AVENUE 1530 CANDLER BLDG.  
CHICAGO ATLANTA, GA.

**TEXAS DISTRIBUTORS FOR VOCALION**

Deal Whittle Music Co. to Carry on Strong Campaign of Exploitation Throughout Their Territory—To Open Elaborate Department

The Deal Whittle Music Co., Dallas, Tex., have been appointed Texas distributors for the Vocalion phonograph, and have arranged to open an elaborate department for the exploitation of that instrument, under the management of H. D. Gupton, an experienced Vocalion man, formerly connected with the Titcher-Goetting Co., of Dallas.

The Deal Whittle Co., who also sell the Aeolian Co.'s piano and Pianola lines, have arranged to cover the territory thoroughly with a large corps of salesmen, and are developing plans for a thorough exploitation of the Vocalion throughout Texas.

The original arrangement was made recently by Charles H. Tracy, of the wholesale Vocalion department of the Aeolian Co., in the course of an extended trip through the Southwest and South. On the trip Mr. Tracy took advantage of the opportunity to visit a number of the company's distributors and dealers, and found them all enjoying a volume of business that taxed their abilities to secure sufficient stocks of machines and records.

**Make a Record Salesman**



out of every repairman. Equip him with an AUTOMATIC CASE, carrying records to demonstrate on your customers' talking-machines. Leatherette and Full Leather finish.

Dealers, jobbers write for prices

**AUTOMATIC CONTAINER CO.**  
29 So. La Salle St. CHICAGO

**REVISED LIST OF SONORA PRICES**

Sonora dealers received recently a communication from Frank J. Coupe, manager of the Sonora Phonograph Co.'s sales department, which gave a revised list of prices for Sonora phonographs, these prices taking effect April 1. These prices are the same as heretofore, with slight changes in the Trovatore, Minuet, Baby Grand and Elite models. The Minuet (new model) replaces the old type by the same name and folders are being sent to dealers. Judging from the enthusiastic comments of the Sonora representatives, this instrument will be one of the popular sellers in the Sonora line.



Sone

SHEER beauty of tone has given the Bush & Lane Phonograph its high rank in the world of music. There may be phonographs which are higher in price, but none which excel the Bush & Lane in faithful reproduction of music. Made in the same factory that produces Bush & Lane Pianos and Cecilian Player-Pianos, this phonograph is a worthy member of a "family" of perfect musical instruments. BUSH & LANE PIANO COMPANY, HOLLAND, MICH.

BUSH & LANE



# L'Artiste

THE ARTIST IN REALITY

## The Outstanding Values in the Realm of Phonographs

L'Artiste phonographs are the one big outstanding value in the phonograph market. Like cabinet beauty in woods, workmanship and design are not offered at their prices.

As musical instruments they are superior to any but the best. L'Artiste reproduction is incomparably satisfying to the most critical. It has mechanical improvements, conveniences and refinements that bring it up to the minute. To show and play the L'Artiste is to make a sale. Its superiorities are irresistible.



**Nine superb models**  
**Five uprights**  
**Four consoles**

All popular woods.

Every model a correct reproduction of popular period designs.

A Beautiful Illustrated Catalogue with Dealer Proposition Sent on Request.

**GRAND RAPIDS PHONOGRAPH COMPANY**  
GRAND RAPIDS, MICHIGAN

**THE PHILADELPHIA SHOW CASE COMPANY**  
DISTRIBUTORS

New York office, 841-845 Bush Terminal Sales Bldg. Philadelphia office, 127 North 13th Street Pittsburgh office, 2002 Jenkins Arcade New England distributors, C. C. Moir, Cambridge, Mass.



## THE SHELLAC MARKET—CONDITIONS AFFECTING SUPPLY

Present Scarcity and General Prospects in the Shellac Field Discussed for The World in an Authoritative Way by D. W. Mulford, of Henry W. Peabody & Co., New York

One of the problems of vital interest to manufacturers of talking machines and records to-day is the question of the shellac market and the conditions affecting the supply. Shellac is an essential in the making of all records and although laboratories have been hard at work day and night seeking a substitute, none has as yet been found. All this is no new story to members of the trade, but the causes for this condition and the contributing factors in the present shortage are not so widely known. In a special interview with *The World*, D. W. Mulford, of the shellac, alcohol and oil import department of Henry W. Peabody & Co., New York, outlined the conditions of the present market and its application to the record industry. Few men are better qualified by knowledge and experience to speak on the subject of shellac than Mr. Mulford. Henry W. Peabody & Co. supply the leading manufacturers and record makers with shellac and need no introduction to the talking machine trade.

In beginning his analysis of the shellac market, Mr. Mulford considered first the matter of supply. He said: "The country to-day is facing a general shortage of shellac because the *Kushmi* crop last Fall was only one-quarter of normal. No large shipments can be looked for from Calcutta, India, until June. This means that the market here can not be replenished until August. It is evident, therefore, that the small *Kushmi* crop must suffice to meet the demands of the trade until late this Summer. Unfortunately the demands last year were so great that there was no balance carried over into this year and this imposes an even greater strain on the small Fall crop.

"In May the *Bysacki* crop is gathered in India and will arrive on the market here some time late in July. This *Bysacki* crop will be 40 per cent of the total production, supposing,

of course, that shipments are normal and there is no undue loss from transportation difficulties. This crop must suffice until January, 1921. With the demands growing steadily, especially in the record field, it can be seen that there is grave danger of a general shortage. This shortage will not be felt in a marked degree till about November of this year, supposing again, that the supply comes through normally. All our predictions must rest upon this basis.

"Now consider for a moment the question of demand. During the war the demand for shellac in the making of munitions and other materials of war diverted a great amount of shellac into military channels. Then in April, 1918, the demand began to be felt everywhere and by June the demand was enormous. Naturally the price rose, for there was only a certain amount of shellac to be had, no matter what the demands upon the supply were. To industries such as the record industry, the electrical insulating industry, emery wheel making, hat making and the like, shellac is absolutely essential. Seventy to seventy-five per cent of the total demand comes from these industries. If the record industry increases with such continued rapidity as it has during the last twelve months, we will face another shortage which will be serious, so serious that it will probably continue to call for more shellac than can possibly be supplied. These industries must have shellac, for they cannot use substitutes as can the paint and varnish industries.

"India is the chief source of supply and here we run up against the difficulties of production. The human factor in the equation here causes all the trouble. The native of India has no ambition to make money. He goes out and makes a few baskets of shellac and sells these for enough money to satisfy his simple wants. To go out and gather twice the number of baskets

and earn twice as much money never even occurs to him. There are here and there a few enterprising natives with some business sense, but the great majority are supremely indifferent.

"As to prices, I would say that the market will be cheapest when the June or *Bysacki* crop is on sale. After that a general rise may be looked for. Exact figures cannot be given or foretold on account of the varying exchange factors. Three elements enter here, the Indian rupee, governing the price in India; the exchange of the rupee into pounds sterling, and the exchange of sterling into American dollars. As all these factors are so unstable no definite predictions can be made. Transportation from distant India is another factor which must be considered. As I have said, our plans must be based upon normal conditions, both of supply and transportation. Damage in transit may materially affect our supply, or shipments may be delayed by shortage of ships. But with the best of luck we will not find the market seriously short until November. After that—but perhaps these record makers will have discovered their substitutes by that time."

### NEW SONORA DISTRIBUTORS

The Sonora Phonograph Co. announced recently the appointment of the American Hardware & Equipment Co., Charlotte, N. C., as distributors for Sonora products in North and South Carolina. This company has an efficient sales organization that has laid out extensive plans for developing Sonora business in its territory.

### TO HANDLE VOCALION LINE

The Stern Furniture Co., of Jackson, Mich., has recently been appointed representative for the Aeolian-Vocalion. The company has arranged to open an attractive department for the exploitation of those instruments. With the addition of the Aeolian-Vocalion the department is preparing for increased business.

**"I may not know much about music,  
but I know what I like."**

Mr. Average Man knows what he likes, and so do we. It's what we specialize in—Emerson Standard 10-inch Gold Seal Records.

In other words—HITS. Song hits—dance hits.

You know, as well as we do, how fast the "hit" records waltz off your shelves. They're always waving goodbye to the more dignified records.

In fact, if it were not for the HITS, you probably would not be selling phonograph records at all. For the record business is built on HITS—the

music 8 out of every 10 people like to listen to.

If you are not handling Emerson Records, you ought to be. May we tell you why? It's a matter of dollars and sense.

There's money as well as music in the two Emersons below:

(10145)  
**You're a Million Miles from Nowhere**  
Tenor Solo.....Walter Scanlan  
**Somebody** Tenor Solo.....Walter Scanlan

(10146)  
**Venetian Moon**  
Fox Trot.....Plantation Jazz Orchestra  
**Rose of the Orient**  
Fox Trot.....Plantation Jazz Orchestra

**Emerson Record Sales Company, Inc.**

EXCLUSIVE METROPOLITAN DISTRIBUTORS

6 West 48th Street, New York City





# Tone Arms that will add Selling Value to your Talking Machines!

## The Mutual

TONE ARMS & SOUND BOXES

### NOTE THESE IMPROVED FEATURES—

1. New, improved Swivel Joint.
2. Insulated Ball Joint.
3. Patented Spring Lock, holding the sound box to the tone-arm.

These patented devices help to eliminate blasts and vibrations. The Mutual Tone Arm is as good as it looks!

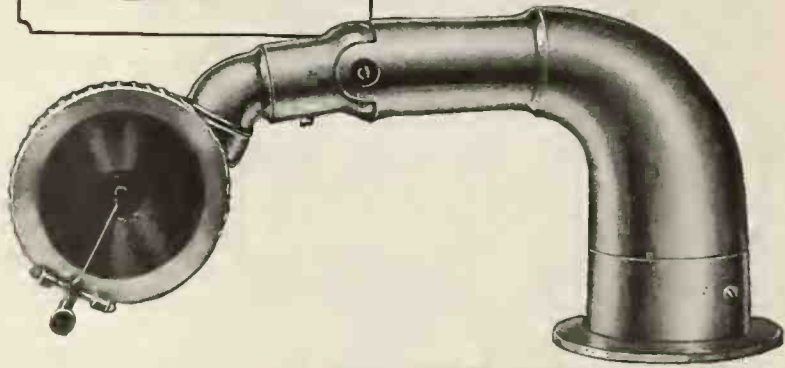
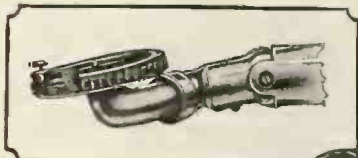

### SURE-FIRE TALKING POINT!

That's what you get when you put this beautiful wooden tone arm on your machine. The eye is pleased with the fine appearance of the Manhattan Tone Arm—the ear is enchanted with the rich, mellow tone.

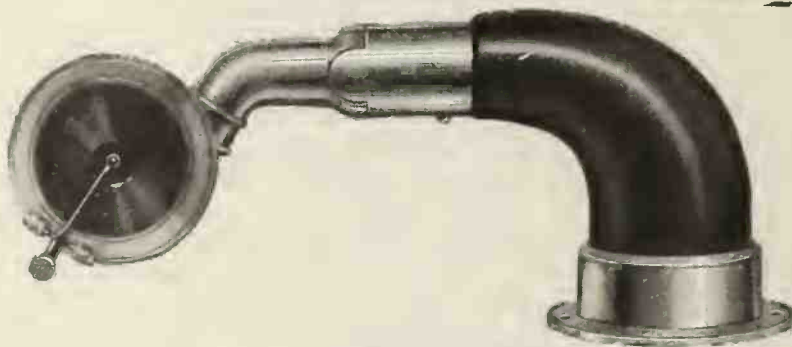

## SUPREME

TONE ARMS & SOUND BOXES

Rugged and simple in design, powerful and appealing in tone—the Supreme Tone Arm is all that its name implies.

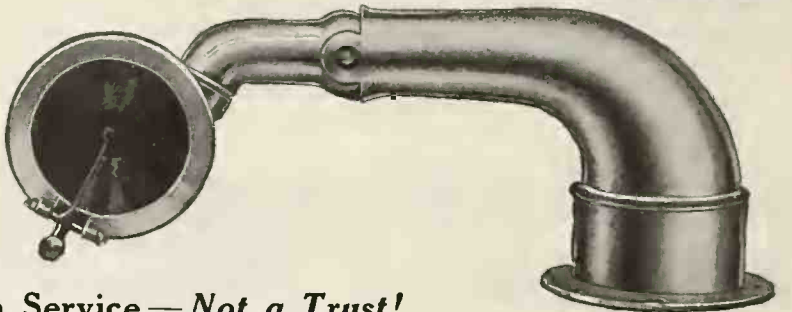

### A Tone Arm Service — Not a Trust!

We admit the claim that one or another of our tone arms is a standard part of many talking machines. Does that prove anything more than that **QUALITY TELLS?**

TONE ARMS OF EXQUISITE SYMMETRY—  
TONE REPRODUCTION OF REMARKABLE ACCURACY—  
TONE ARMS THAT ADD SELLING VALUE TO YOUR TALKING MACHINES—

**PRICED IN QUANTITIES \$2.50 up** *Write at once for further information relative to sizes and prices. Let us know your requirements—we're equipped to solve your tone arm problems*

As manufacturers of the Mutual, Supreme, and Manhattan Tone Arms, we sell direct to talking machine manufacturers. Wm. Phillips, President and Gen'l Mgr. of the Mutual Talking Machine Co. and Supreme Phono. Parts Co., Treasurer of Manhattan Phono. Parts Co.

## WILLIAM PHILLIPS SERVICE

*Manufacturers ~ ~ Engineers ~ ~ Consultants*

145 West 45<sup>th</sup> Street  
New York City

Chicago Representative: H. Engel, Republic Building.



**HOSPITAL PATIENTS ENJOY MUSIC**

New Invention Installed in Walter Reed Hospital in Washington Enables Patients to Hear and Enjoy Concerts and News of the Day

WASHINGTON, D. C., April 6.—The Walter Reed General Hospital has recently installed an electro-static talking machine which makes it possible for every patient in the institution to enjoy musical concerts daily and also hear the news



**Aeolian-Vocalion Electrically Equipped** of the day as read in the hospital library. An Aeolian-Vocalion has been placed in the library and has been equipped with a special electrical device. At each bed there is a bedside receiving set which is connected with the master instrument. When the machine is playing a record the music may be heard at any bedside in the hospital by merely raising the small receiver to the ear. The invention was designed particularly to entertain the outdoor patients who were deprived of the pleasure of the indoor concerts which were a feature of the daily

entertainment. Now it is possible for every patient to enjoy the music.

Another use to which the invention has been



**Enjoying Vocalion Through Bedside Set**

put is a most interesting and valuable one. A recording attachment has been devised and each morning the news of the day is read aloud into the receiver in the library and is transmitted to every bed in the hospital. It has been found very successful and the patients are now able to keep up with what is going on in the outside world, not only in the way of news, but also with the latest music. The photographs show the Aeolian-Vocalion with its electric attachment and also a patient listening to one of the latest songs through the bedside receiving set.

**OPEN NEW PLANT IN CANADA**

Lyrphone Co. of America, Establish Well Equipped Plant in Toronto to Take Care of Growing Trade Over the Border

The Lyrphone Co. of America, Newark, N. J., manufacturers of the well-known Lyric lateral record, early this month opened a new factory in Toronto, Canada. While the factory is already in operation, much equipment is being added, and when the capacity of the plant is reached there will be over seventy record presses in service.

The Lyrphone Co. tell of a constant increase in the demands for their products during the past few months, and for some time they have felt the necessity for opening a Canadian plant, in order to better care for dealers there.

In addition to the above, the Newark plant of the concern is being equipped with many new presses and some of these are of an improved type which will almost double the present daily output of records.

**NEW BUILDING IN DALLAS, TEXAS**

Texas-Oklahoma Phonograph Co. to Erect New Home for Its Growing Business

DALLAS, TEX., April 3.—The Texas-Oklahoma Phonograph Co., jobbers for the Edison line in Oklahoma and Texas, with headquarters in this city, has completed plans for the erection of a commodious new building to house the company's business. The new building, which is to cost \$200,000, will be erected in the financial district of the city, where switching facilities are available to simplify the shipping question.

The Texas-Oklahoma Phonograph Co. was organized in 1915, and has grown and made steady progress since that time. The officers of the company are: A. H. Curry, president and general manager; F. C. Beattie, assistant general manager; O. C. Feltner, chief of accounting department; John R. Spann, sales manager; W. F. Taylor, advertising and promotion manager; C. L. Rankin, traffic manager; A. C.

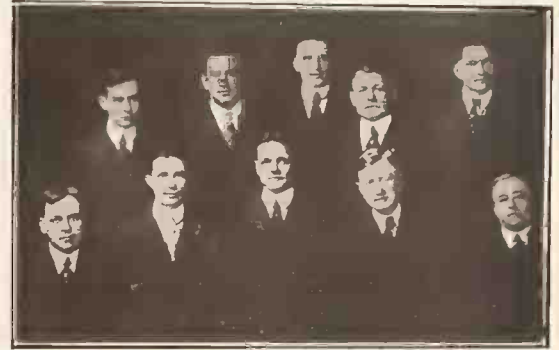

Officers and Representatives of the Company Dennis, Oklahoma representative; J. K. Patterson, south Texas representative; O. P. Curry, east Texas representative, and B. A. Ward, west Texas and New Mexico representative. The board meets four times a year to discuss matters of interest to the company and to the Edison trade.

**SPECIAL ROOMS FOR DEALERS**

BALTIMORE, MD., April 1.—Cohen & Hughes, Victor wholesalers, have opened a private room in their headquarters, in this city, which will be entirely at the service of the Victor dealer. This room is to be known as Victor Dealers' Baltimore Headquarters, and is richly furnished and decorated. Cohen & Hughes recently entertained their dealers for the second time at a record recital at their headquarters, at which a luncheon was also served. The success of both these affairs was so pronounced that I. Son Cohen, president of the company, has decided to make these meetings regular. They will be presided over by Manager Elmer Walz.

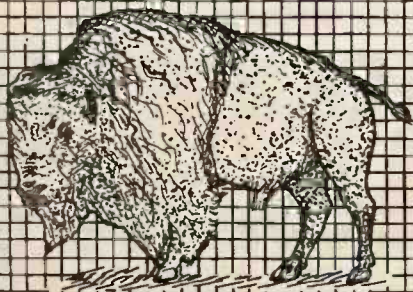

**Wholesale**

**Victor**

**Service**

**BUFFALO TALKING MACHINE CO., INC.**

BUFFALO, N. Y.





## VICTOR JOBBERS' ASS'N HOLDS IMPORTANT MEETINGS

Executive Committee of National Association Meets With General Membership in Both Chicago and New York—Enthusiastic Over Plans for the Future

What are declared by the members of the National Association of Talking Machine Jobbers to have been the most successful and resultful meetings ever held in the history of that or-



Geo. E. Mickel, President

ganization were the sessions held in Chicago on Monday and Tuesday, March 22-23, and in New York on March 24, attended by the Executive Committee of the Association and by the membership in the East and West respectively.

The Chicago meeting was held at the Sherman House, the arrangements for the session being made by Leslie C. Wiswell of Lyon & Healy. The meeting, attended by thirty-eight members, was announced as an educational session and the results measured up to promises. Instead of devoting themselves to a discussion of factory conditions and the question of stock shortage, the jobbers proceeded to forget those matters and devote themselves entirely to a discussion of their own situation as distributing factors.

At both the Chicago and New York meetings, the latter being held at the Hotel Knickerbocker, the jobbers were very frank in their talks on business conditions as affecting their interests, and particularly frank in placing their cards on the table and telling what must and what must not be done to enable them to make definite progress along lines that can be recognized as constructive. It was realized that the question of distribution will have added importance as the output of the factory is increased and begins to catch up with the demand, and that this is the time for the jobbers to put their

businesses on a most efficient basis, in order to take full advantage of the opportunities for business development that will assuredly come to them.

There was notable at both meetings a distinctly better feeling among the jobbers regarding the general supply situation as well as the outlook for the future. There was likewise in evidence a spirit of co-operation and a willingness to exchange business ideas of value that bode well for the future of the organization and for the trade as a whole. The discussion was general and practically everyone took part.

Gilbert H. Montague, general counsel for the



Wm. H. Reynolds, Treasurer

Association, was present at both the Chicago and New York meetings, and analyzed the general legislative and legal situation and offered some valuable suggestions and advice for the guidance of the jobbers in their affairs.

The New York meeting was the largest ever held outside of the regular annual conventions of the general body, sixty-eight jobbers being present.

The Executive Committee, consisting of George E. Mickel, Omaha, president, who presided; Thomas H. Green, New York, vice-president; A. A. Trostler, Kansas City, secretary; W. H. Reynolds, Mobile, Ala., treasurer, and P. B. Whitsit, J. N. Blackman, Louis Buehn, Daniel Creed, A. A. Grinnell, Burton J. Pierce

### ILSLEY'S GRAPHITE PHONO SPRING LUBRICANT

Ilsey's Lubricant makes the Motor make good  
Is prepared in the proper consistency, will not run out, dry up, or become sticky or rancid. Remains in its original form indefinitely.  
Put up in 1, 5, 10, 25 and 50-pound cans for dealers.

This lubricant is also put up in 4-ounce cans to retail at 25 cents each under the trade name of

### EUREKA NOISELESS TALKING MACHINE LUBRICANT

Write for special proposition to jobbers.

ILSLEY-DOUBLEDAY & CO., 229-231 Front St., New York

and H. A. Winkelman, attended both the Chicago and New York sessions, leaving the former city via the Broadway Limited over the Pennsylvania road on March 23 and going immediately into session on their arrival in New York. The only absentees from the committee were James F. Bowers, J. C. Roush and Andrew J. McCarthy.

Those who attended the Chicago meeting in addition to the Executive Committee included: C. W. Miller, Penn Phono. Co., Philadelphia, Pa.; W. Zitzman, A. Hospe Co., Omaha, Neb.; J. P. Keper, A. Hospe Co., Omaha, Neb.; C. K. Bennett, Eclipse Musical Co., Cleveland, Ohio; John Elliott Clark, John Elliott Clark Co., Salt Lake City, Utah; H. B. Sixsmith, Mickel Bros., Omaha, Neb.; Lester Burchfield, Sanger Bros., Dallas, Texas; Ross P. Curtice, R. P. Curtice Co., Lincoln, Neb.; George A. Mairs, W. J. Dyer & Bro., St. Paul, Minn.; J. F. Houck, Houck Piano Co., Memphis, Tenn.; Jack Fisher, C. C. Mellor Co., Pittsburgh, Pa.; G. H. Rewbridge, Frederick



A. A. Trostler, Secretary

Piano Co., Pittsburgh, Pa.; Chas. Womeldorf, Toledo Talking Machine Co., Toledo, Ohio; G. F. Ruez, Badger Talking Machine Co., Milwaukee, Wis.; R. A. Bryant, Knight-Campbell Music Co., Denver, Colo.; E. H. Uhl, Rudolph

(Continued on page 74)

If you want the Best, insist on getting

# The De Luxe Stylus

THE BEST SEMI-PERMANENT NEEDLE MADE

Plays 100-200 Records

FULL TONE

Produces Rich, Clear Tone

MEDIUM TONE

## 3 for 30 cents

LET THE "DE LUXE" SPEAK FOR ITSELF AND  
SEND FOR FREE SAMPLES, DISCOUNTS, ETC.

**DUO TONE COMPANY, Inc.**

Sole Manufacturers of the De Luxe Needles

ANSONIA, CONN.



# VITANOLA

The Phonograph of Marvelous Tone

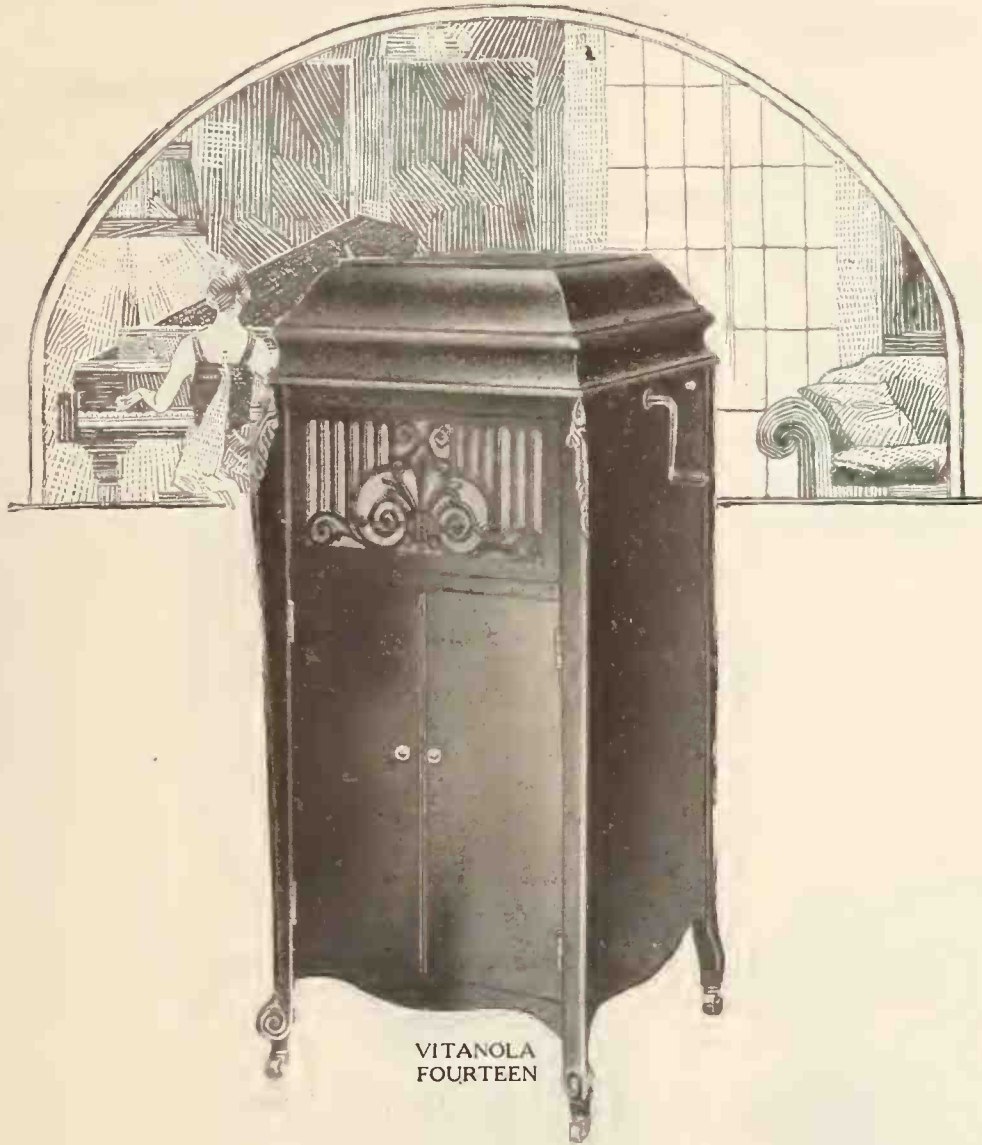

VITANOLA  
FOURTEEN

## *Cash In On Vitanola Advertising*

A six-figure fortune is being spent this year in the largest magazines and best metropolitan newspapers of this country to make Vitanola quality known to the buying public everywhere.

If you are already handling the Vitanola line, connect up your store with this powerful publicity campaign—get Vitanolas in the window—on the floor—so people who have read about Vitanola in the publications will come in your store to see them. Ask us for our dealer helps—they're trade builders.

If you're not selling Vitanolas and the agency in your vicinity is open, you're missing opportunity if you don't investigate and act.

Write for the new book, "How to Make a Phonograph Department Pay Big." It's yours for the asking.

VITANOLA TALKING MACHINE COMPANY, 508 West 35th Street, CHICAGO, U. S. A.

Metropolitan Sales Representatives: M. M. ROEMER SALES CORP., 332 8th Ave., New York, N. Y.





**Bert Williams can't borrow any money in his song "I'm Sorry I Ain't Got It, You Could Have It If I Had It" Blues, but you'll be wise to borrow a lot to invest in this unique record. A-2877.**

**Columbia Graphophone Co.  
NEW YORK**

**MEETINGS OF VICTOR JOBBERS**

*(Continued from page 72)*

Wurlitzer Co., Chicago; J. F. Bowers, Lyon & Healy, Chicago; W. C. Griffiths, Chicago Talking Machine Co., Chicago; L. C. Wiswell, Lyon & Healy, Chicago; A. R. Boone, Talking Machine Co., Birmingham, Ala.; H. J. Shartle, Cleveland Talking Machine Co., Cleveland; F. H. Putnam, Putnam & Page, Peoria, Ill., and W. Geissler and M. Denham, Chicago Talking Machine Co.

Among those who were present at the New York session were E. H. Droop, of E. F. Droop & Sons Co., of Washington; Ernest Urchs, of Phillips & Crew, Atlanta, Ga.; L. G. Collings, Collings & Co., Newark, N. J.; Elmer Walz, Cohen & Hughes, Baltimore; C. B. Snow, Cressey & Allen, Portland, Me.; Frank Corley, the Corley Co., Richmond, Va.; F. P. Oliver, Blackman Talking Machine Co., New York; Florence Heppie, C. J. Heppie & Son, Philadelphia; Emanuel Blout, New York; C. L. Price, Ormes, Inc., New York; W. D. and C. N.

Andrews, of Buffalo; E. J. Chapman, Rochester, N. Y.; George Stewart, Stewart Talking Machine Co., Indianapolis, with his bride; E. C. Rauth, Koerber-Brenner Co., and many others.

After the meeting in New York the Executive Committee left for Philadelphia, where an extended conference was held with Charles K. Haddon, Ralph L. Freeman, B. G. Royal and C. G. Child of the Victor Co.

**TALKING MACHINE MEN, INC., MEET**

**Nominations of Officers Made—Annual Banquet Planned for April 14—Considerable Interest Shown in Matter of Charging Interest**

At the regular monthly meeting on Wednesday, March 17, at the Hotel Pennsylvania of the Talking Machine Men, Inc., composed of dealers from New York, New Jersey and Connecticut, the nominations of officers for the coming year were made as follows: President, Sol Lazarus; vice-president for New York, M. W.

After the session held in Chicago a dinner party was given at Terrace Gardens, and after dinner all present attended a performance at Cohan's Grand Opera House. In the afternoon the ladies were entertained by Miss Elizabeth Wiswell, daughter of L. C. Wiswell, who took them for an auto ride throughout the boulevard system of Chicago. She was assisted by Miss Ada Mack, Mr. Wiswell's secretary.

Gibbons; vice-president for New Jersey, Emil Perkin; vice-president for Connecticut, James Donnelly; secretary, E. H. Brown; treasurer, A. Galuchie. Nominees for the executive committee were: Irwin Kurtz, J. Schick, E. Leins, Paul Helfer, William Berdy, Harold Bersin and S. Goldfinger. In a petition presented by M. Max, another ticket was offered, being substantially the same as that offered by the regular nominating committee, with the following changes: A. P. McCoy, vice-president for Connecticut; Irwin Kurtz, secretary; Messrs. Hunt, Arison, Perkin, Clinton and Mielke were added to the executive committee. These nominations will be voted on at the next meeting on April 21.

The matter of charging interest on talking machine sales took up a great part of the afternoon, the general opinion being that dealers should charge this interest and that mention of the interest charge should be incorporated in all advertisements in order that the general public should be informed and that all dealers might be on the same footing. It was decided to find out the opinion of the trade and call a special meeting to settle the matter once for all.

Plans were announced for the annual banquet scheduled to be held at the Hotel Pennsylvania on April 14. J. J. Davin, for the entertainment committee, outlined the program, which was designed to entertain, business being barred. The program was brightened by such stars as the All Star Trio; the Landauettes, a novelty orchestra composed of members of the Landau stores in Wilkes-Barre and Hazleton, Pa.; Al Bernard; Ted Moses, with some of Leo Feist's songsters; the Sullivan Orchestra from the Moulin Rouge; Edna Darch, of the Chicago Opera Co.; Elsie Baker and others.

All members of the industry were invited and a special invitation was sent to the heads of the large manufacturing companies.

**MAKE COLUMBIA RECORDINGS**

The Original Six, a jazz orchestra from Wilmington, Del., were recently in New York City to make recordings for the Columbia Co.

Joseph C. Smith has just opened a new talking machine store in La Porte, Ind., at 1013 Lincoln Way.

**"WHAT ARE YOU SHORT?"**

Get in touch with us. We have everything in the phonograph line—Needles, Tone Arms, Motors, Cabinets, all kinds of accessories and repair parts. We specialize on Main Springs, Bettertone Phonographs. Let us do your repairs.

**PLEASING SOUND PHONOGRAPH CO.,**  
204-206 East 113th St., New York.



**THE VENUS BELLE**

(SHAPED LIKE A BELL)

is a remarkable instrument in **Tone and Volume Design and Finish**

Because of its bell-shaped construction it is acoustically correct. Its long and tapering horn of TEMPERED wood affords a clarity and resonance that are so marked that one demonstration results in

**Instant Sales**

Three models in mahogany, walnut, oak and ebony.

Dealers who desire exclusive territory should make application at once.

**The VENUS CO.**

*Also Makers of The VENUS Phonograph Needle*

**Factory and General Offices: Liberty & Western Aves. Cincinnati, Ohio, U.S.A.**

**Chicago Sales Office: Room 435, Fine Arts Bldg.**

**MODEL-B, VENUS BELLE**

Showing Record Compartment holding 70 records.

Equipped with Modulator.

Height 35 inches. Width 2 feet 7 inches. Length 3 feet



# Cleartone

PHONOGRAPH  
SPEAKS FOR ITSELF



No. 150—\$85



No. 100—\$75



No. 135—Price \$135



Model 105—Price \$105



No. 200—\$100



Model 175—Price \$175

THE MOST WONDERFUL TALKING MACHINE OF THE PRESENT AGE  
AT THE PRICE. AN INSTRUMENT OF SUPREME  
VALUE, TONE AND QUALITY

The CLEARTONE has become very popular because of its quality, splendid value and the advertising sales campaign that now stands in back of it. DEALERS! Watch us grow—write for our agency and grow with us.

LATEST 84-PAGE CATALOG NOW READY!

LUCKY 13 PHONOGRAPH CO., 46 East 12th Street, New York





NEEDLES

SAPPHIRES

DIAMONDS

## SPECIAL OPPORTUNITY

Sell Highest Grade Needles Packed in Envelopes.  
We Are Getting 100 Million Per Month—All Live  
Dealers Are with Us—Send for Samples and Particulars

### Opera Needles

are made to our own specifications.

They are highly-polished, nickel-plated needles.

A glance at a sample will convince you that they are the finest finished needles on the market.

You can be assured of the quality by sending for free samples.

We are the largest jobbers of Steel Needles in the world

Must sell one billion needles in 1920  
2 customers 100 million each;  
who's next?

Prices as follows:

10,000 lots, 45c. per M  
1,000,000 lots, 35c. per M

100,000 lots, 40c. per M  
5,000,000 lots, 32c. per M

We are the largest jobbers of Sapphires and Diamonds in the world

We are the original headquarters for genuine Clearartone Sapphires and Diamonds

All our genuine Diamond and Sapphire Points are absolutely uniform, silver-plated and the highest quality jewels on the market

Prices subject to revision without notice

Sapphire Balls	Sapphire Points	Genuine Diamonds
Each	Each	Each
Dozen Lots..... 16c	Dozen Lots..... 18c	Sample..... \$1.75
Hundred Lots..... 13c	Hundred Lots..... 15c	Dozen Lots..... 1.50
Thousand Lots..... 12c	Thousand Lots..... 13½c	Hundred Lots..... 1.40
5-Thousand Lots..... 11c	5-Thousand Lots..... 12c	Thousand Lots..... 1.25
		5-Thousand Lots..... 1.15

SPECIAL PRICES ON LARGER QUANTITIES

1920 Catalog Listing Everything a Phonograph Man Needs

LUCKY 13 PHONOGRAPH CO., 46 East 12th Street, New York



# Cleartone

PHONOGRAPH  
SPEAKS FOR ITSELF

## Motors, Sundries and Supplies

### STOP! LOOK! READ!

Something new for Lucky 13!  
We are now manufacturing our own motor, and can offer immediate deliveries in any quantity.

Send for samples—you can't go wrong.

This is the best buy on the motor market to-day.

Half Dozen, \$9.75 Each.

Dozen, \$9.00 Each.

100 Lots, \$8.50 Each.

1000 Lots, \$8.00 Each.

Bevel-gear wind; plays seven 10-inch records without re-wiring. Complete with all parts including 12-inch turn table.

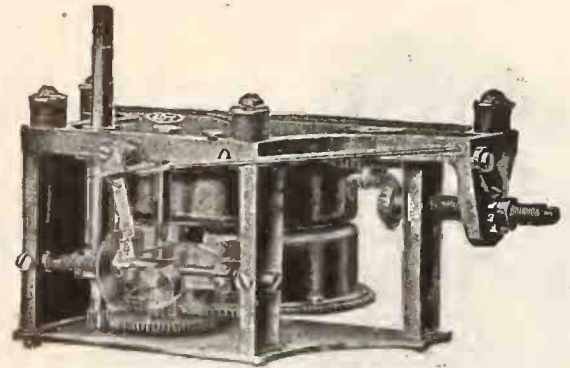

CLEARTONE MOTOR NO. 11

### SPECIALS FOR MOTOR, TONEARM, REPRODUCER AND CABINET MANUFACTURERS

Cast-iron Turn Tables in any quantity at the right price. Felts in Discs or Squares, 10 and 12-inch, all-wool.

Mica, first and second quality, clear, in any size.

Main springs and governor springs to fit any motor  
Tone modifier rods.  
Continuous hinges.  
Cover Supports.

Your inquiries will have our best attention.

### SUNDRY DEPARTMENT

#### MOTORS

- No. 1, double-spring, 10-inch turntable, plays 2 10-inch records ..... \$3.75
- No. 2, double-spring, 10-inch turntable, plays 3 10-inch records, \$4.00, with 12-inch turntable ..... 4.25
- No. 9, double-spring, 12-inch turntable, plays 3 10-inch records, castiron frame ..... 7.85
- No. 3, double-spring, 12-inch turntable, plays 4 10-inch records, castiron frame ..... 9.85
- No. 11, double-spring, 12-inch turntable, plays 7 10-inch records, castiron frame, bevel gear wind..... 9.75

#### TONE ARMS AND REPRODUCERS

(Play All Records)

- No. 2 .....Per set \$1.75
- No. 3 .....Per set 1.95

- No. 4 .....Per set 4.00
  - No. 6 .....Per set 3.75
  - No. 7 .....Per set 3.75
  - No. 9 .....Per set 2.95
- Sonora tone arm with a reproducer to fit

#### MAIN SPRINGS

- No. 00, 5/8 in., 9 ft. .... 29c
- No. 01, 3/4 in., 9 ft. .... 25c
- No. 02, 3/4 in., 7 ft. .... 25c
- No. 1, 3/4 in., 10 ft. .... 39c
- No. 01A, 3/4 in., 10 ft. .... 49c
- No. 2, 13-16 in., 10 ft. .... 39c
- No. 3, 7/8 in., 11 ft. .... 49c
- No. 4, 1 in., 10 ft. .... 49c
- No. 5, 1 in., 11 ft., heavy ..... 69c
- No. 6 1 1/4 in., 11 ft. .... 99c
- No. 7, 1 in., 25 gauge, 15 ft. .... 89c

We also carry other size main springs to fit Victor, Columbia and all other motors.

Special prices on springs in large quantities.

#### RECORDS—COLUMBIA

10-inch double disc records, 42c each; 12-in., 60c each.

We also manufacture special machine parts, such as worm gears, stampings, or any screw machine parts for motor; reproducer and part manufacturers.

Special quotations given to quantity buyers in Canada and other export points.

Write for our 84-page catalog, the only one of its kind in America, illustrating 33 different styles of talking machines and over 500 different phonographic parts.

# LUCKY 13 PHONOGRAPH CO.

46 East Twelfth Street

New York





## The Best Talking Machine Needle on the Market

PACKED IN COUNTER SALESMEN

50 Needles to a box and they retail at 10 cents per box.  
60 boxes to a package, \$6.00. This package costs you \$3.90 net.  
Your profit is \$2.10 and your customer gets a needle that will give satisfaction.

### THE FRED. GRETSCH MANUFACTURING COMPANY

60 Broadway *Manufacturers of Musical Instruments* BROOKLYN, N. Y.  
Canadian Wholesale Agent, H. A. BEMISTER, 10 Victoria Street, Montreal, Can.  
Western Distributor: WALTER S. GRAY, 530 Chronicle Building, San Francisco, Cal.

#### GOING STRONG IN WASHINGTON

O. J. DeMoll & Co. Doing Big Business as Distributors for Aeolian-Vocalions, Melodee Rolls and Other Aeolian Co. Products

WASHINGTON, D. C., April 3.—O. J. DeMoll & Co., distributors of Aeolian-Vocalions and Melodee music rolls, as well as retailers of Pianolas and other Aeolian Co. products, have assumed



Home of O. J. DeMoll & Co.

a very strong position in the local trade through such connections and have built up a volume of business that is taxing the capacity of the large six-story building occupied by the company.

The company maintains an elaborate Vocalion department on the fourth floor of its building with a wholesale record department on the sixth floor, and the wholesale Melodee roll department on the second floor of the building. In addition a large warehouse is maintained in an-

other section of the city for the storing of reserve stock, but the demands of the business have increased so largely that plans for a larger warehouse are under way. This has been found absolutely necessary.

K. C. Markward is in charge of the Aeolian wholesale departments, which cover the territory embracing Virginia, North and South Carolina, Georgia, as well as Washington, D. C., proper. Howard R. Green looks after the details of the shipping, and O. J. DeMoll, head of the company, maintains an active supervision over the business as a whole.

Mr. DeMoll reports that the new lateral cut Vocalion records have made a particular appeal to the dealers and the public, and that heavy orders have been and are being received for the selections offered in the latest lists, which have been found most interesting.

DeMoll & Co. have long been prominent in the local field as retailers of the Aeolian Co. Pianolas and pianos.

#### NEW PLANT FOR F. C. KENT CO.

Modern Factory Being Erected on Large Site Recently Purchased in Irvington, N. J.

Following the recent purchase of a plot of ground containing 17,500 square feet in Irvington, N. J., the F. C. Kent Co., Newark, N. J., well-known manufacturers of phonograph accessories, is now erecting a modern factory on the site. According to the statement of W. S. File, secretary of the above company, this step has been made necessary on account of the increased business and because of the fact that its present plant, although quite large, will not permit of further expansion.

The new factory will be ready for occupancy in May of this year, and is being equipped with the most modern machinery, much of it specially designed. The plant will be what is known as a daylight factory. All the equipment as well as the arrangements are being made with an eye to giving the greatest efficiency. The production of this concern will be greatly increased, and it is thought that with added facilities it will be able to take good care of its constantly increasing business.

#### MAKE A PERMANENT DISPLAY

Walters & Barry Corp. Featuring Brooks Phonograph Line at Headquarters in Buffalo

BUFFALO, N. Y., April 5.—A permanent display of Brooks automatic repeating phonographs has been installed by the Walters & Barry Corp. in the Associated Service Building, where this company makes its headquarters. This display is attracting considerable attention, and many



Display of Walters & Barry Corp.

out of town visitors have commented upon the distinctive features of the Brooks phonograph.

The Walters & Barry Corp., which is the local distributor for the Brooks repeating phonograph has closed several important deals as a direct result of this exhibit, and invitations have been extended the dealers throughout the State to examine the display at their convenience. The company expects to change the display from time to time in order to give the public and the trade a fair idea of the diversity of the Brooks product.

#### WILL HANDLE EMERSON RECORDS

The Emerson Record Sales Co., New York, local Emerson distributors, announced this week that the Central Music Shop, which is the retail establishment of the well-known house of G. Schirmer, Inc., 3 East Forty-third street, New York, will handle the complete line of Emerson records. This deal was closed after investigating the many makes of records.

Announcing the Eighth Release of

# OKeh Records

- 4081 { See Old Man Moen Smile.....Vocal
- { Chasing The Blues.....Vocal
- 4082 { All I Want Is You.....Vocal
- { When My Baby Smiles.....Vocal
- 4083 { Old Fashioned Garden.....Vocal
- { Venetian Moon.....Vocal
- 4084 { Melodious Jazz.....Vocal
- { He Went In Like a Lion and Came Out Like a Lamb.....Vocal
- 4085 { See Saw.....Fox-trot
- { Korlutha.....One-step

- 4086 { Lone Star.....Fox-trot
- { Desert Dreams.....Fox-trot
- 4087 { Afghanistan.....Fox-trot
- { Buddha.....Fox-trot
- 4088 { Waiting Under Western Skies.....Waltz
- { Somebody.....One-step
- 4080 { My Isle of Golden Dreams.....Waltz
- { In and Out.....One-step
- 4079 { I'll See You in C-U-B-A.....Vocal
- { Dardanelle.....Vocal

Phone Barclay 2493

## ZIEGLER, BAKER & JOHNSON

Service In or Out of Town

100 Chambers Street, New York City



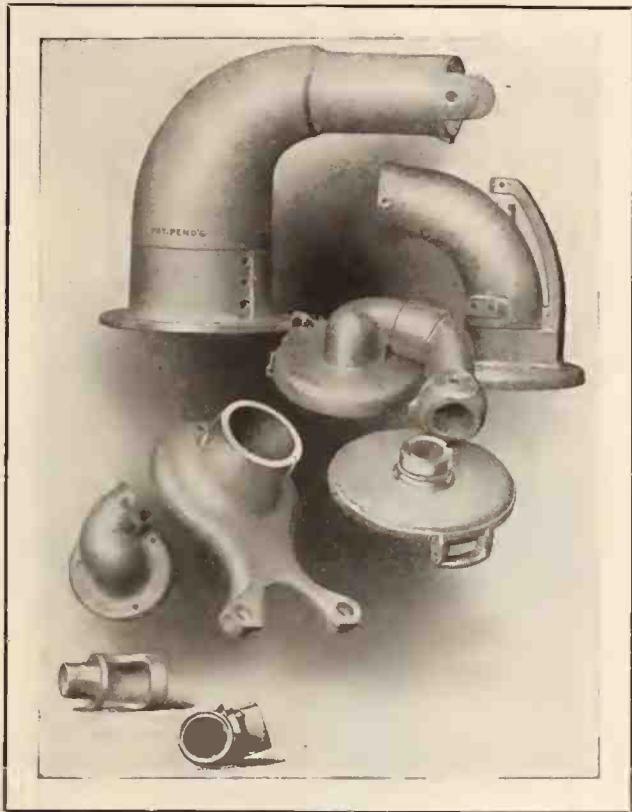

*When you need  
Die Castings—  
you need Doehler*

DOEHLER is more than a plant which produces Die Castings in quantity—it is the largest Die Casting concern in the world.

Its trained and efficient personnel is prepared to design, produce and deliver your die castings in whatever quantity you need—in a practically finished state.

Are you aware of the possibilities of Doehler Die Castings? Write us for information today

THE WORLD'S LARGEST MANUFACTURERS OF DIE CASTINGS  
**DOEHLER DIE-CASTING CO.**  
HEAD OFFICE AND EASTERN PLANT: BROOKLYN, N.Y. CENTRAL PLANT: TOLEDO, OHIO. WESTERN PLANT: CHICAGO, ILL.  
SALES OFFICES IN ALL PRINCIPAL CITIES

DDC-17

**QUITE AN INFLUX OF VISITORS**

Prominent Sonora Jobbers at New York Headquarters of Sonora Co. Tell of Prosperity

During the past few weeks, quite a number of Sonora jobbers have visited the executive offices of the company at 279 Broadway, and discussed plans and policies for the coming year with the executive officers. Frank J. Coupe, manager of the sales department, conferred at length with these jobbers, and was gratified to learn that in every instance the outlook for 1920 is excellent. The demand for Sonora product is far beyond all expectations, and one of the prime objects of the jobbers' visits to New York was to impress upon the

Sonora executives the necessity of securing immediate shipments of merchandise.

Among the callers were Fred E. Yahr, Yahr & Lange Drug Co., Milwaukee, Wis.; Frank Steers, Magnavox Co., San Francisco, Cal.; J. O. Morris, M. S. & E., Boston, Mass.; E. N. Upshaw, Southern Sonora Phono Co., Atlanta, Ga.; R. R. Ellis, Hessig-Ellis Drug Co., Memphis, Tenn.; Graham French, Smith, Kline & French, Philadelphia, Pa.; C. L. Marshall, C. L. Marshall & Co., Detroit, Mich., and I. Montagnes, I. Montagnes & Co., Toronto.

**NEW PATHE DEALERS' ASSOCIATION**

Retailers in Southern Territory Meet in Nashville, Tenn., and Organize

NASHVILLE, TENN., April 3.—At the headquarters of Gray & Dudley, Pathé distributors, a Dealers' Association was recently formed. The following officers will direct the destinies of the new association: W. A. Broyles, of the Broyles Furniture Co., of Birmingham, Ala., president; J. W. Cook, of the Cook Furniture Co., of Mt. Pleasant, first vice-president; M. B. Botts, of the Buler Drug Co., of Sheffield, Ala., second vice-president; Jeff Martin, of the Martin Drug Co., of Pulaski, secretary-treasurer. Meetings of the Association will be held once or twice each year. At the first meeting of the Association Walter L. Eckhardt of the Interstate Phonograph Co., Pathé distributors for Philadelphia, and W. V. Plyant of Petersburg, gave a very interesting demonstration of the proper selling of Pathé machines. Addresses were also made by James Watters, secretary of the Pathé Frères Phonograph Co.; O. N. Kiess, field supervisor of the Pathé Frères Phonograph Co.; M. L. Willis, of the Unit Construction Co., and B. E. Hill, of Gray & Dudley.

**SECURE AGENCY FOR VOCALION**

Adams & Allcorn, prominent music dealers of Waco, Tex., have recently secured the agency

for the Aeolian-Vocalion and intend to devote an attractive department to that instrument.



**That's What They All Say!**

- THANKS! "for such prompt shipment." Ordered March 3rd, shipped March 20th.
- THANKS! "for such good envelopes." Heavy grey, brown and manila paper.
- THANKS! "for the attractive design; our envelopes are now an asset to our business."
- THANKS! "for that list of Easter records: it helped us to sell MORE Easter records. Will you feature Bridal music on your June envelopes?"

It's thanks for this and thanks for that. Our many satisfied customers see a real lasting sales-aid in the original service we are rendering Victor dealers thru the medium of specially prepared wrapping envelopes with advertising "punch" printed all over them.

You will thank us, too, after you have learned from experience how much real good this service renders to your record department.

For envelopes quite a bit different Clip coupon on Page 45, or pin this ad to your letter-head and mail to

**LU-FRANC SALES SERVICE**  
1231 Dime Bank Building Detroit, Mich.

*Announcing—*

to dealers that we are the Sales Managers in the New Jersey District for



*"It's the best Talking Machine after all."*

**NEWTON - ELTING**

DISTRIBUTING CORPORATION

114 N. Broad St. Trenton, N. J.



# The MODERNOLA

*A Home Delight to Ear and Eye*

---

## *Sales and Satisfaction—*

The phonograph prospect becomes enthusiastic about the Modernola at first sight. That enthusiasm carries with it desire for ownership. Sales are quickly made.

And the Modernola *stays sold.*

Placed in the home its wonderful beauty and the cheerful atmosphere created by the silk lamp shade at once make it a fixture—one of the prized possessions of the home.

There are many, many instances where Modernolas are replacing instruments nationally popularized through publicity. Unique design and the lamp feature, as well as perfection of tone and fineness of finish, give The Modernola an irresistible appeal.

Sales rights are constantly becoming more valuable.

---



## MODERNOLA COMPANY

JOHNSTOWN, PA.

*Eastern Representative, Geo. Seiffert*

Greeley 2978

45 West 34th St., New York



**“Christ in Flanders” and “In Flanders Fields” are two Charles Harrison tenor solos that will sell and keep on selling. Order big. A-2892.**

**Columbia Graphophone Co.  
NEW YORK**



**SALESMANSHIP CLASSES A SUCCESS**

The Classes Organized by the Koerber-Brenner Co. Listen to Addresses by T. Maetten and Joseph F. Kieselhorst—Plan and Scope of This Progressive Sales Organization

Sr. Louis, Mo., April 6.—The class in Victor salesmanship recently organized by the Koerber-Brenner Co., of this city, is proving to be quite a success. It is a continuation of the work done by the service department. The classes,



Salesmanship Class in Session

which are limited to eight people, are held in the service shop on the main floor of the Koerber-Brenner Building, which has been furnished with all the necessary equipment for an intensive study of the business. The course is planned to reach the sales people who find it impossible to attend the classes at the Victor factory just at present, and to the end that the benefit to the dealer of such sales help may not be delayed until they can go to Camden.

The curriculum is based as far as possible on that of the Red Seal School of the Victor factory and has as its prime object the adding of knowledge of more records, especially red seal records, to the salesman's working capital. Many records are heard carefully, discussed, descriptions searched for and all information finally written out and filed so as to be of easy access when the salesperson goes back to work. Such other subjects as Victor artists, Victor policies, the differences in Victor salesmanship, pronunciation of titles and names of foreign artists, how to approach customers and how to analyze their attitude and influence them, how to introduce a customer to better music, balancing the customer's record collection, the order in which records should be played, and other vital topics.

T. Maetten, secretary of the Tri-State Dealers, Association, addressed the first class on "Application of Knowledge," and J. F. Kieselhorst of the Kieselhorst Piano Co. of Alton the second class on the "Value of Study."

The people shown in the illustrations herewith are Miss Eleanor S. Caldwell, with Stix, Baer & Fuller; Miss Marian Cartwright, of the Kieselhorst Piano Co.; Harry S. Hunter, of the Tower Talking Machine Co.; Miss Aurelia Lippscomb, Miss Jane Thomas, of Scruggs-Vandervoort & Barney; Miss Laura Hagge, of Stix, Baer & Fuller; Miss Helen Heet, of the DeMerville Piano Co., all of St. Louis, and Stephen Paridy, of Lehman's Music House, East St. Louis, Ill.

In addition to these the following have taken the course: Miss Emma Hemmer and Miss Ethel Repple, of the Kieselhorst Piano Co., St. Louis; Miss Ida Kayser, Miss Ella Marklin, Miss Marie Aubermann and Miss Raeburn Car-

son, of Scruggs-Vandervoort & Barney; Miss Ione Maupin, of Park's Music House, Hannibal, Mo.; Mrs. Margaret Paridy, of Lehman's Music House, East St. Louis, Ill.; Miss Frances Schaeffer, of Wathen Drug Co., Morganfield, Ky.; Miss Mary Henry, of Smith-Reis Piano Co.; Henry Beardslee, of Koerber-Brenner Co.; Miss Virginia Adams and Miss Anna Schwab, of the Kieselhorst Piano Co., Alton, Ill.; Miss Orpha Hopkins, of Haussler Bros., Centralia, Ill.; and Miss Olivia Wagner, of W. L. Rhein Piano Co., Belleville, Ill.

The classes will continue until a better way to meet the needs of sales people is found.

**EMERSON RECORDS WITH DAVEGA**

Prominent Talking Machine Retailers of New York to Handle Line in Their Four Stores

The Emerson Record Sales Co. of New York, local distributors of Emerson records have through their special representative, Frank Elliott, placed Emerson records in the four stores of S. B. Davega Co., located in West 125th street; Commodore Hotel; 15 Cortlandt street; 831 Broadway, New York City. This means that the live Davega organization will push the sale of Emerson records with characteristic energy and their customers can rely upon getting the latest song and dance hits in good quantities at the earliest possible moment.

**NEW VOCALION DEALERS**

Among the recent additions to the list of Aeolian-Vocalion dealers in the Ohio territory is the Windsor Jewelry Co. of Lima, O., who have arranged to feature the line in a big way.

**D  
I  
T  
S  
O  
N**

**Humanly Efficient**

*Best Describes the*

**DITSON VICTOR SERVICE**

DITSON SERVICE does not confine itself to the work of forwarding goods from the factory to the dealer, but goes beyond and offers to the dealer that personal interest that helps him meet problems and make profits.

*Ideal for New England Victor Dealers*

*Victor Exclusively*

**OLIVER DITSON COMPANY, Boston**

CHAS. H. DITSON & CO., New York

**S  
E  
R  
V  
I  
C  
E**



# REPAIRS

TALKING MACHINE TROUBLES AND HOW TO REMEDY THEM

Conducted by Andrew H. Dodin

[This department of The Talking Machine World is designed for the service of all classes of our readers, including those who make, and those who sell, talking machines.]

Andrew H. Dodin, who conducts this department, has a wide and enviable reputation as a repairer of talking machines at 176 Sixth avenue, New York. Tell him your troubles through The World and he will help you if possible. The service is free.—Editor.]

## QUESTIONS AND ANSWERS

Regarding Reproducers

TRAER, IA., March 16, 1920.

Editor, Talking Machine World:—

I have been making numerous experiments with phonograph reproducers and am puzzled regarding the means for controlling the volume of tone. Can you give me an idea how I can regulate the tone? By that I mean I want a reproducer as loud as the Columbia, while the one I am experimenting with is softer than the Brunswick, although very distinct. Does the size of the needle arm, the thickness of the mica, or the distance of the mica from the back of the reproducer make any particular difference?

LELAND Q. SELZER.

Answer:—You will find by experimenting that the size of the mica diaphragm and of the needle arm makes a great difference in the results obtained with the reproducer. The thickness of the diaphragm must be accurate to scale and conform to its diameter. The space left between the diaphragm and the back of the sound-box is also very important and is determined by the diameter of the diaphragm, as is also the hole, or sound outlet, into the tone arm. The weight of the needle bar, the distance between the fulcrum point and the needle point and from the fulcrum to the point attached to the diaphragm are all important and require very accurate figuring to produce the best results. Another point of great importance is the material of which the needle arm is constructed. A point often neglected is the amount of pressure placed on the diaphragm of the gaskets:

it is often made so tight that diaphragm cannot vibrate freely—just enough pressure is required to hold diaphragm firm.

It is only by experimenting that you can find the various sizes and materials to give best results and it is a good plan to use some of the well-known sound boxes as a guide.

Regarding a Book on Repairing

SOUTHBRIDGE, MASS., March 21, 1920.

A. H. Dodin, care Talking Machine World:—

Are there not some books published on the repair of talking machines, as in other lines of repair work? I think it would be of great advantage to repairmen to have a book of that kind. We get some good points through The

Talking Machine World, but would like to have the information together and easily available. I do all the repairing in my town and would like to get a book on talking machine repairing similar to the books on piano repairing and would pay any price for a volume of that kind.

Answer:—I do not know of any book published on the repair of talking machines. Nearly all the large talking machine companies publish booklets on the repair and care of their own particular make of motor or sound box and I am sure that if you were to communicate with some of the larger companies they would be pleased to furnish you with this information.

## COMPLIMENTS FOR DETERLING

Zig-Zag Record File of This Concern Contains Many Distinctive Features

TIPTON, IND., April 5.—During the past few months, the Deterling Mfg. Co. of this city, manufacturer of the Deterling talking machine,

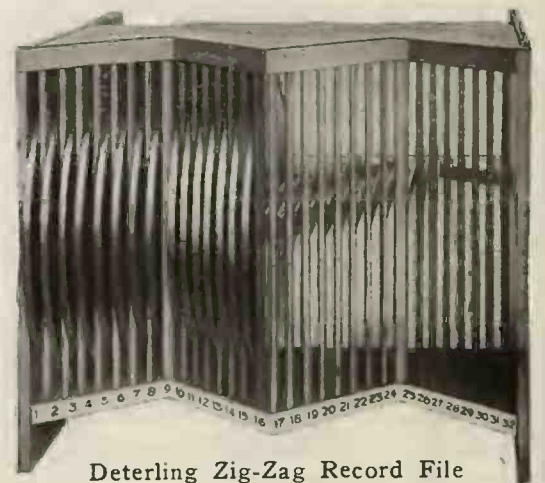

Deterling Zig-Zag Record File

has received many letters from its dealers complimenting the company upon the zig-zag record file while is one of the distinctive features of this machine. The company's representatives state that this record file is proving an effective sales argument, and has contributed materially to the success of the instrument.

The purpose of this unique filing system is to provide a place for every record, with an arrangement whereby the owner of the machine can obtain any record without disturbing the other records. The file is attractive in appearance, and is being featured to advantage by Deterling dealers.

Are you laying plans for your Summer campaign? The sooner the better.

**BANG!**

**HERE IT IS!!**

**The "Hustylus"**

THE little wonder-device that makes Pathé records playable on practically every instrument. The greatest thing that has yet happened for the Pathé dealer. Sweeps all clumsy "adapters" into the discard. As simple to use as any steel needle. It adds many million instrument owners to the Pathé dealer's market.

Ask your Jobber

**Herbert & Huesgen Co.**  
Sole Sales Agents  
18 East 42nd Street  
New York

# The Booth Felt Company, Inc.

## Mechanical Felt Products

Turntable Felts

Motor Felt Washers

Motor Brake Felts

Needle Rest Felts

Cabinet Strip Felt

We carry a large stock of well assorted merchandise which insures prompt deliveries.

If interested in Velour or Velveten Discs we can supply them.

## FACTORIES

BROOKLYN, N. Y.

463-473 Nineteenth Street

CHICAGO, ILL.

732 Sherman Street



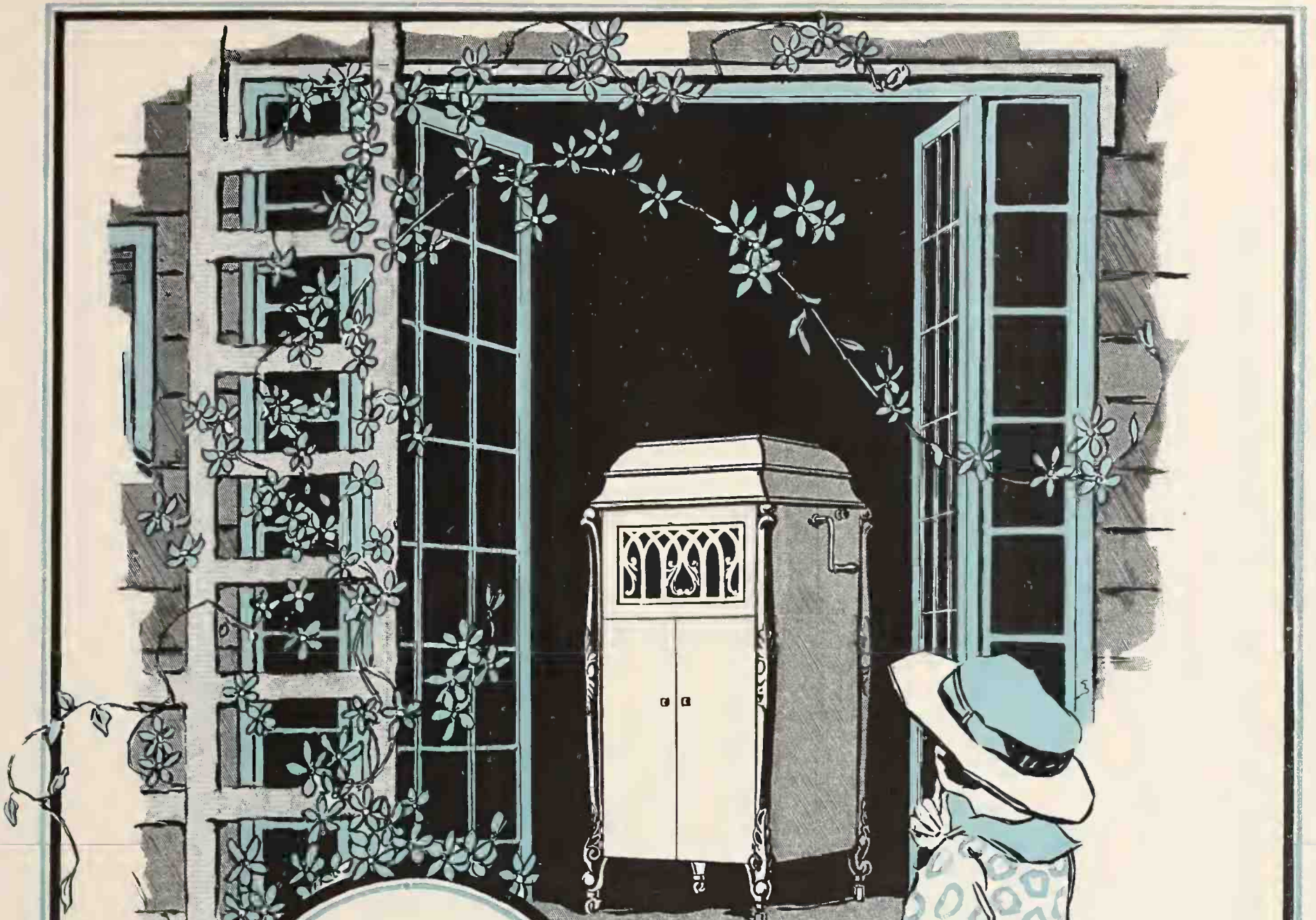

## Spring

Summer, Fall or Winter  
you will find  
No Deviation

In the uniform high Quality of  
**Stradivara Phonographs**

Built in a factory devoted for several decades to the production of art piano-fortes of superlative merit.

Above we present the handsome Model 200 Stradivara. You will find combined in it for your selling advantage such quality features as: 7/8-inch case stock—five ply; genuine veneers; flawless finish; genuine gold-plated trimmings; extra large 4-spring motor; velvet-covered turn-table; filing device; and other splendid features too numerous to mention here.

If you wish to represent a quality phonograph for 1920, and to reap the profits therefrom, a post-card will bring you full details. Write to-day—it will pay you!

Complete line                      Advertising service

**The Compton-Price Company**

COSHOCTON, OHIO

Built for the Pacific Coast

trade by

The Pacific Phonograph Mfg. Co.  
Portland, Ore.

# STRADIVARA

"KNOWN FOR TONE"







*The Trade in* **BOSTON** *and* **NEW ENGLAND**  
 JOHN H. WILSON, Manager  
 324 WASHINGTON ST., BOSTON, MASS.

BOSTON, Mass., April 10.—March has a better story to tell than had February so far as detriments to business are concerned. There have been mild days aplenty and with the let-up of frigid weather and the melting of the snows so as to let the cargoes of freight proceed to their destination things are beginning to get back to normal. In the early part of the month, with the freight embargo carried over from the latter part of the previous month, there was quite a period when some of the local distributors did not receive a single talking machine from their respective factories. But all that is a thing of the past. In the meantime there has been no complaint about business; there has been plenty of it, but facing such conditions there was not the goods to supply the demand. All the distributing centers report that the factories are adding considerably to their output, which means that there will not be any long delays in getting orders filled.

**H. W. Lunn to Visit London**

H. W. Lunn, one of the valued members of the Vocalion staff at the Boylston street headquarters, is looking forward eagerly to a trip to his home in England this summer. Mr. Lunn, who has been in this country six years, plans to sail on the Cunarder "Kais. Aug. Victoria" from New York June 12 and to be away three months. He will pay a visit to Aeolian Hall in London and make a careful study of the talking machine conditions in Great Britain.

**Reports Better Tone to Business**

Manager Fred E. Mann, of the Columbia Co., is back from a tour among some of the western Massachusetts centres and he reports a better tone in business than he has found in some time; everybody is happy because machines can be shipped more expeditiously than in a long

**Steinert Service Serves**

**M. STEINERT & SONS CO.**

35 ARCH ST.



BOSTON

**WHOLESALE HEADQUARTERS**

With our newly completed service department, a reality and a model for the good of the retailer, we are prepared to offer valuable ideas to our retailers to help resell such goods as are now obtainable.

time and dealers can therefore satisfy their customers. The new headquarters at 1000 Washington street are gradually getting into shape and it is hoped that in the May issue of The World there will be some pictures giving the

Columbia enthusiasts some adequate idea of the fine quarters the company now has in its new location. It is a satisfying thought that with all the disadvantages of moving so large a plant the dealers were inconvenienced only to the smallest degree.

**Alexander Steinert Returns**

Alexander Steinert, head of M. Steinert & Sons Co., returned home yesterday from Pinehurst, S. C., where he has been for six weeks. During his absence his place at the Boylston street establishment was assumed by his son, Robert Steinert, who to-day, now that his father is back, has returned to work in his accustomed place in the Arch street quarters, where Kenneth Reed, as head of the Victor wholesale department, has been finding business unusually good.

**Business Makes Encouraging Progress**

Under Manager Wheatley's supervision the wholesale and retail business of the Vocalion is making encouraging advances. Especially is the wholesale end big, this being largely accounted for by the fact of the popularity of the lateral cut records, which are selling fast. Manager Wheatley has lately arranged for a wholesale department in West Brookline street, at the South End of the city, where a large consignment of goods can be kept for immediate needs.

**Roxbury Store Falls Into Line**

The Prest Music Shop, at 187A Dudley street, Roxbury, is one of the latest talking machine headquarters to be opened in that part of the city. The store carries the Steger and Columbia lines, Emerson records and Q R S rolls and is building up a large business.

**March Made Great Showing**

Manager Joseph Burke, of the Musical Supply & Equipment Co., says that business has shown a big improvement lately, not only because orders have increased, for they have been doing that for some time, but because these same orders can be filled better since shipments are being received with more regularity due to the improvement in the weather conditions. March, for instance, was quite the biggest month his department has yet experienced and this was

(Continued on page 86)

"New England Service for  
 New England Dealers"

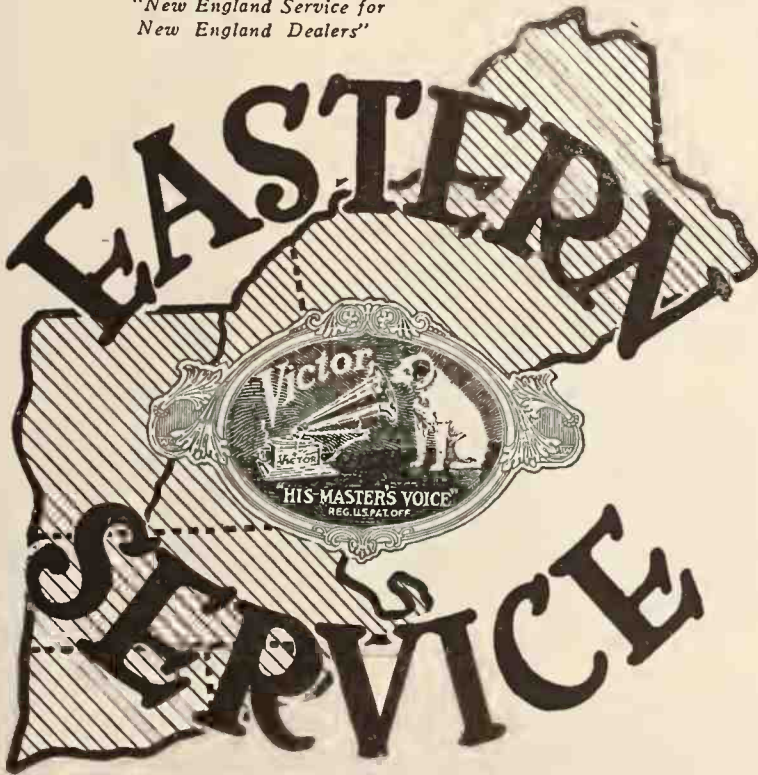

A SLOGAN  
 Ad. Ever  
 noticed our  
 slogan?—New  
 England Serv-  
 ice for New  
 England Deal-  
 ers!

**WE** limit our territory only, but are  
 unlimited in our desire to help you.  
 It is a good habit to use Eastern Service.

**The Eastern Talking Machine Co.**

VICTOR WHOLESALERS

85 Essex Street

BOSTON



1879  
1920

The  
POINT  
MEASURING  
GAUGE

**A. E. BAGSHAW**  
*Laboratory Expert & Mfg. Superintendent*

**A.** E. BAGSHAW, laboratory expert and superintendent of manufacturing of the W. H. Bagshaw Co., Lowell, Mass., is here seen measuring the fineness of the point of a talking machine needle. Needles cannot be larger in diameter at a given distance from the point than the groove itself. So, all needles are inspected to see that only perfect needles leave the Bagshaw plant. The temper and finish of Bagshaw needles are also passed upon by him. The close-up view of the needle measuring machines shows a needle in the process of being measured. Bagshaw needles are the best and are made in the greatest quantities, this honor being due to our policy of shipping only super-tested needles. A. E. Bagshaw is a stockholder in the company; has been with this organization over 32 years, and is one of the sons of the late Walter H. Bagshaw.

W. H. BAGSHAW & COMPANY



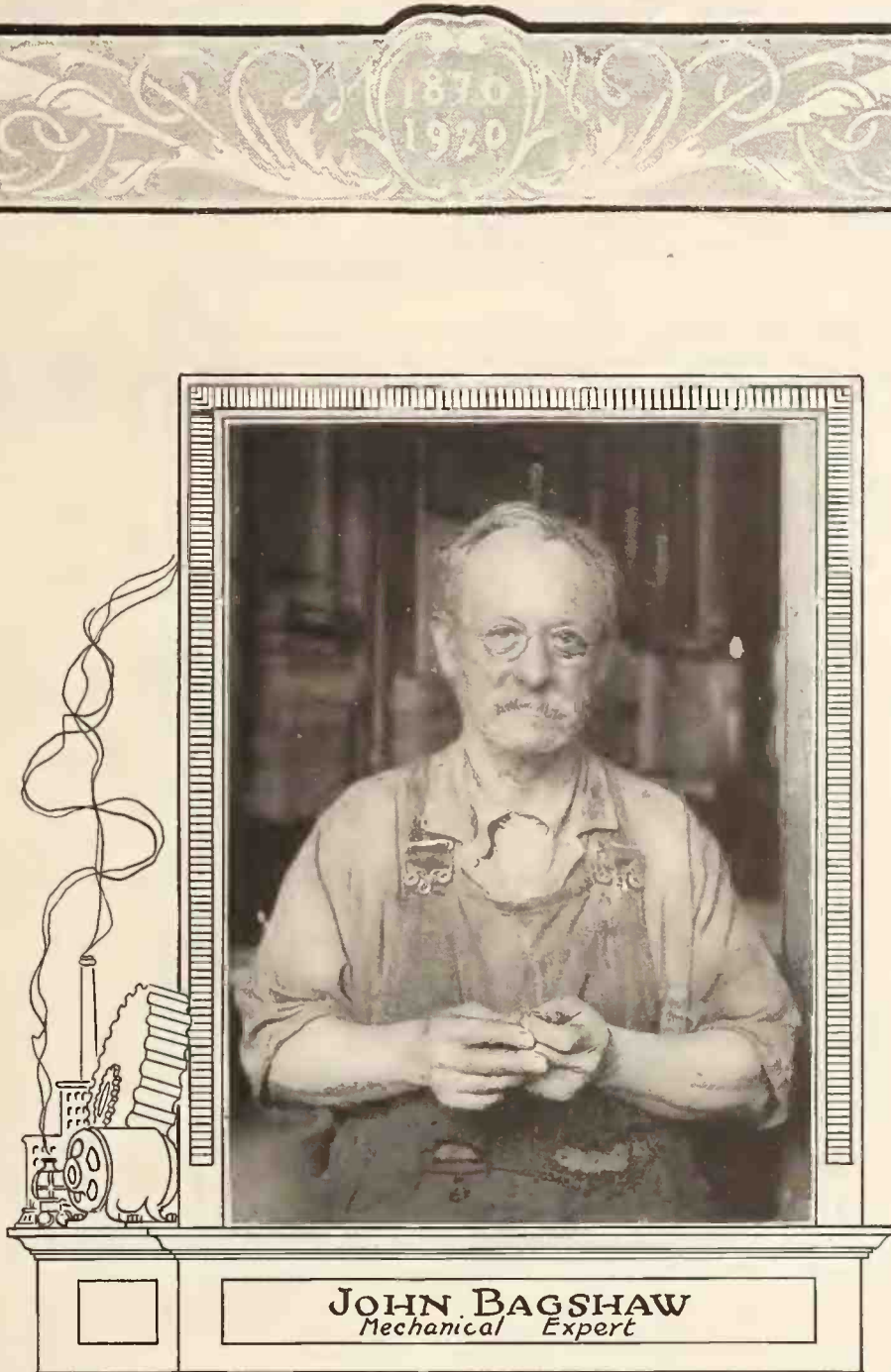

WHEN Walter H. Bagshaw, founder of the W. H. Bagshaw Co., started in business in 1870, he had one employe at that time. This man is John Bagshaw, mechanical expert, and after 50 years of continuous service, he is still in the employ of this organization. He is of the old school type, with an up-to-date polish, and it is safe to say that billions of talking machine needles have passed through his hands. Hale and hearty, he is ever on the job, and always insisting that only the best needles pass through his hands. Mr. Bagshaw to-day works, and works hard, because he likes work. He also enjoys his reputation of being able to wear out a pair of overalls faster than any one in the plant.

W. H. BAGSHAW  
COMPANY  
LOWELL, MASS.



THE TRADE IN BOSTON AND NEW ENGLAND—(Continued from page 83)

**NEW ENGLAND DEALERS!**

We beg to announce that we  
have secured the distribution of

**Phonographs**

For the New England Territory

**“A Quality Line for High Class Dealers”**

**9 Period Models—5 Uprights, 4 Consoles**  
Cabinet Work, Equipment and Tone Unsurpassed

Liberal Discounts—Exclusive Territory—Boston Shipments

**C. C. MOIR****181 Tremont Street**

..

..

..

..

**Boston, Mass.**

Write for Catalog and Discounts or call and see the Line

especially true in the Sonora machines and Emerson records and Q R S rolls. J. O. Morris, president of the company, was in town recently for a few days.

Manager Burke says that the appearance of Eddie Cantor with the “Follies,” which comes here in a few weeks, has stimulated a great demand for this artist’s numbers as recorded on the Emerson records.

**Joins the Beacon Organization**

George W. Orcutt, formerly connected with the Sherman Service, Inc., production efficiency engineers, has recently been taken into the Beacon organization.

**Victor Shipments Speeding Up**

Wholesale Manager Herbert Shoemaker, of the Eastern Co., on his last return from the Victor factory, stated that while there had been a slight lull in business for a brief period goods were coming along very well and this was

especially true of the records; and that arrangements had been made whereby the Eastern Co. was to get its April first allotment through in a single shipment instead of being split up, which Mr. Shoemaker thought was a good evidence that the factory was speeding up.

**Enjoy Visit to Victor Plant**

J. E. Dunham, the hustling traveling representative of the Eastern Co., personally conducted a group of Victor dealers over to the factory the latter half of the month. In the party were Mr. Titus, head of the talking machine department of the Jordan Marsh Co., of this city; P. J. Mann, of Worcester; Raymond Heidner, of Holyoke, and Mr. Emery, of Orange. As this was the first visit of these four gentlemen everything they saw was of special interest and their visit was made the more valuable because of several talks which some of the Victor officials found time to give

them. All the departments were carefully inspected and the representatives returned better able than ever because of a new fund of information to exploit the virtues of Victor goods.

**Have Greatly Increased Business**

The Phonograph Supply Co. of New England, so ably conducted by Ralph Silverman and George Rosen, has recently put out a price list to the trade which is proving a great aid to dealers in checking up their stock of repair parts, accessories and supplies. These young men, who are known as “Two Live Wires,” have increased their business tremendously in the last six months.

**Distinguished Visitor from Chicago**

R. J. Waters, of the Moeller-Waters, Inc., which house has lately been appointed representatives in the Western territory for the Beacon Phonograph Co., was in Boston for

(Continued on page 89)

**VITANOLA**  
The Phonograph of Marvelous Tone

Vitanola  
Phonographs

Records  
Mysto Needles

**S. W. SHARMAT & SON**

Wholesale Distributors

5 Bromfield Street, Boston, Mass.

From Sharmat's Golden Treasury.

**Soliloquy from “Hamlet”**

(with apologies to Shakespeare)

To be or not to be! That is the question,  
Were it not better to raise loud the cry  
Of value, tone, construction, before all  
Than to degrade in low and nimble traffic?  
Cheating the public of their honest shares  
Because of an extra discount, laid out in  
repairs,

Thus cupidity doth make sluggards of us all  
While VITANOLA dealers watch the  
others fall.

A machine that plays all  
makes of records and gives  
their full tone-value—in short,  
absolute satisfaction.

**Dealers! Get in touch with  
this HOUSE**



# S-O-N-A-T-A

## THE PHONOGRAPH OF PERFECTION

*Deliveries when you need them*  
*Product of highest quality*  
*Price under standard machines*

### YOU NEED THIS FULL LINE

After looking over the entire field, we have selected the SONATA line for New England distribution because we believe that it offers to the dealer the best opportunity available for quick sales; because the tone producing quality is unsurpassed by any machine; because we can deliver to the dealer when he needs deliveries; because he can sell it at prices below the prices of other standard makes.

### SPECIFICATIONS

**Motor.** Best type, with every known improvement—double springs, bevel gears, heavy cast steel frame—plays five 10-inch records with one winding; fully guaranteed for one year.

**Tone Arm.** Patented reproducer—only one known that will reproduce exact quality of the human voice and instruments, and give big volume; plays all records.

**Horn.** Constructed of chemically treated wood, scientifically designed on model of the human throat.

**Cabinets.** Made of best kiln dried woods, heavy and durable—put together by skilled artisans.

**Designs.** Six machines in the line, graceful and attractive—harmonious with any period of furniture; special period designs now under way.

**Record Shelves.** Large record chamber with heavy shelves for record albums.

**Price.** Less than any standard phonograph of the best quality.

THE LINE YOU HAVE BEEN HOPING FOR

*Write or wire us today—our salesman will see you*

EXCLUSIVE NEW ENGLAND DISTRIBUTORS

MUSICAL PRODUCTS COMPANY

134 SUMMER STREET (Temporary address)

BOSTON, MASS.



# KRAFT-BATES AND SPENCER INC.

## NEW ENGLAND DISTRIBUTORS

*Brunswick*  
PHONOGRAPHS AND RECORDS

### Dealer Confidence and Comparisons Sell

*Brunswick*  
PHONOGRAPHS AND RECORDS

The chance sale, the substitute, the premium phonograph is *not* The Brunswick.

Dealer confidence and comparisons compel its purchase.

Straight merit—very little selling talk—and performance, close Brunswick sales.

#### The Method of Reproduction

It is the Brunswick Method of Reproduction that has captivated phonograph marts. The method is exclusive, scientific, simple, practical.

It interprets music in a language anybody can understand. It doesn't require an expert to appreciate how it gives color, charm and exquisiteness to tone.

Furthermore, The Brunswick opens up an entire world of phonograph music.

Heretofore the instrument determined one's range of selection. On The Brunswick any make record can be played.

These accomplishments are made possible by the two features comprising the Method of Reproduction. They are the Ultona and the Tone Amplifier.

#### The Ultona

The Ultona is an all-in-one patented reproducer which plays all records with faithful regard for the requirements of each make.

A simple turn of the hand gives the proper needle, diaphragm and weight.

#### The Tone Amplifier

This is an oval, all-wood, vibrant throat moulded to meet musical and acoustical laws. Being entirely free from metal, harsh rasping noises are avoided.

Phonographic tones, hitherto lost, are restored by the Tone Amplifier.

#### Brunswick Dealers

Brunswick Dealers take pride in selling and demonstrating this super-phonograph.

They capitalize its reputation, its performance, its all-round superiority.

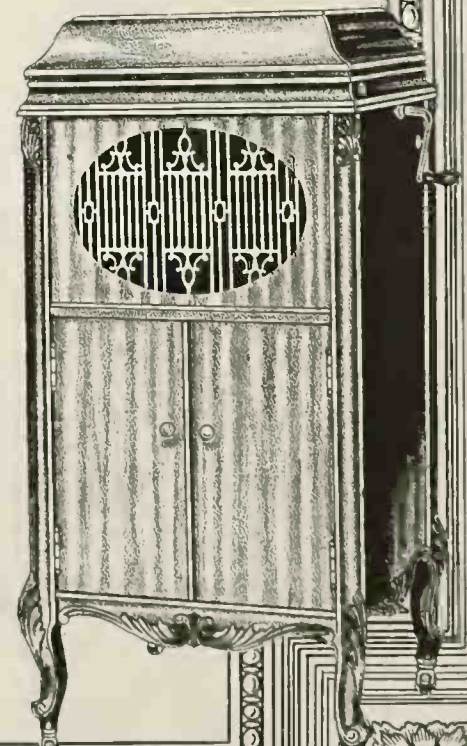

### KRAFT-BATES & SPENCER

INCORPORATED

156 Boylston Street, BOSTON, MASS.

NEW ENGLAND DISTRIBUTORS

TONOPHONE, VICTROLENE, MOTROLAS

Steel Needles Jewel Points Albums

Record Brushes Khaki Covers



THE TRADE IN BOSTON AND NEW ENGLAND—(Continued from page 86)

**LONG**  
TRADE MARK

Disc Record, Player Roll and Sheet Music Cabinets. The Best in the Market  
*See Display Ad in This Issue*

**Peerless Record Album**

Standard of Quality to preserve the Records  
*See Display Ad in This Issue*

Send your orders for both these lines to  
**L. W. HOUGH, 20 Sudbury St., Boston, Mass.**  
New England Representative

several days the latter part of March arranging for the supply of talking machines for his territory. Mr. Waters formerly was connected with the Brunswick-Balke-Collender Co., and his partner, Mr. Moeller, was for a number of years director of sales for the Carson Pirie Co., of Chicago. Moeller-Waters, Inc., plan to do a large amount of circularizing and advertising throughout the Middle West states.

**New Pathé Dealers in New England**

Here is a list of the Pathé dealers that have been established by Manager Ainslie in New England during the last month: Bowdoin Music Supply Co., 148 Court street, Boston, of which Mr. Mondello is the owner; W. S. Underwood Co., 18 Holden street, North Adams, Mass.; New England Phonograph Shop, 85B Green street, Boston; Charles H. Prew, Foxboro, Mass.; W. A. Burbank, 627 Main street, Worcester; E. Ledaux, Nashua, N. H.

Manager Ainslie reports that March was the biggest Pathé month in the history of the business of the Hallet & Davis Co. and the sale of records and machines has been highly satisfactory, the latter having been limited only by the lack of consignments, which was due in large degree to the freight embargo. For more than a month there wasn't a machine reaching the local headquarters, but within the space of a week lately there were five carloads arriving,

and all these machines are being shipped out as fast as the cars can be unloaded.

Manager Ainslie has lately moved into larger offices and Miss Taylor, his secretary, has secured an assistant because of the rapid growth of the work. A new man on the selling force is J. A. Towle. He will spend his time in New England and will call regularly on the trade. Mr. Towle has been with the Hallet & Davis Co. since his return from France, where he was gassed while in service.

**L'Artiste in New England Territory**

C. C. Moir, who has a large Cambridge establishment and who was mentioned last month as having just taken over L'Artiste for the New England territory, has arranged to come into the retail section of Boston and has opened quarters at 181 Tremont street, which is near the corner of Boylston street and in the very heart of the retail music section of the city. Attractive quarters have been opened on the second floor and will be in charge of R. H. Monroe, who will be very active in placing L'Artiste before the New England public. Mr. Moir will make a special bid for the best distributors throughout the New England territory and attractive literature exploiting the merits of this talking machine is being distributed.

**Open Important Distributing Branch**

The New England Piano & Phonograph Co., of Boylston street, has opened a branch headquarters near the Italian end of the city, which will cater almost entirely to the musical needs of the sons of Sunny Italy. This branch is located at 205 Hanover street and is in charge of Adolph Sansinnatti, who has lately been with the Hallet & Davis Co., where he built up the Italian trade considerably. In his new post he will push the Empire and the New England talking machines. Two other distributing places which the company has just opened up are at Hyde Park, conducted by George Fisher, and in Medford, where Clare & Peters are the

**MICA**  
**DIAPHRAGMS**

**Watson Brothers, Inc.**  
170 PURCHASE ST.  
BOSTON - - - MASS.

managers. R. C. Rose, traveling representative for the New England, spent a part of March in Maine, and before returning he arranged for opening an office at Portland for the benefit of Maine dealers.

**Now the Lansing Co.**

The talking machine trade that has used the khaki coverings handled by E. H. Lansing, who died in New York, following the piano men's convention, will be interested in learning that the business heretofore conducted at 611 Washington street has been taken over by the Conway Co. and hereafter will be known as the Lansing Co. The Conway Co. has leased quarters at the corner of Eliot and Warrenton street and the Lansing Co.'s business will hereafter be conducted from this address. A. J. Cullen, who came East from Chicago a couple of months ago to associate himself with the Pathé department of the Hallet & Davis Co., is the president of the Lansing Co. and Miss Paresky, long with Mr. Lansing, will be the vice-president and manager.

**Big Orders for Beacon Co.**

Richard Nelson, head of the Beacon Phonograph Co., states that up to the present time orders have been received from distributors for  
*(Continued on page 90)*



**The Phonograph of Quality**



Discriminating, wide-awake dealers will welcome the opportunity of selling the Pathé Talking Machine—a phonograph that has won the endorsement of the world's most prominent musicians and music lovers everywhere.

The dealer who has the Pathé agency is assured of a profitable increase in sales and a distinct lead over local competition. The completeness of the Pathé line of phonographs and records and Pathé Service offer a distinct selling advantage.

Add the Pathé to your other line of Phonographs and Records—You'll find that it will not only prove a Best Seller but will put you in touch with a clientele that will prove a decided asset to your business.

Write us for particulars. Our dealers' proposition will be of interest to you.

**Hallet & Davis Piano Co.**

146 BOYLSTON STREET, BOSTON, MASS.

Exclusive Distributors for New England States for **Pathé Phonographs and Pathé Records.**

New York Office:  
Hallet & Davis Bldg., 18 East 42d Street





THE TRADE IN BOSTON AND NEW ENGLAND—(Continued from page 89)

nearly \$2,000,000 worth of business for the current year and besides it has had many applications for agencies which have not been accepted because of the large volume of business already booked. Some of the dealers recently given franchises for the Beacon are F. H. Tucker & Son, Haverhill; Knuepfer & Dimmock, Lawrence; C. A. Peabody Co., Brockton; C. H. Norris, Boston, and John J. Kelly, Lynn.

Attended the Jobbers' Convention

George A. Dodge, of the Eastern Talking Machine Co.; Henry A. Winkelman, of the Oliver Ditson Co., and Kenneth Reed, of the Steinert house, all Victor representatives, were over in New York for the meeting of the National Association of Talking Machine Jobbers. Mr. Winkelman, who is a member of the executive board, also was over in Chicago before stopping in New York. Charles Snow, of Cressey & Allen, of Portland, Me., also was one of those from New England who got over to the New York meeting.

Attended Supervisors' Convention

Miss Grace Barr, of the educational department of the Steinert Co., attended the Music Supervisors' Convention in Philadelphia the middle of March.

Joins Horning Forces

L. M. Evans has joined Frank Horning's new Victor shop in Boylston street. Evans is a member of the Harvard Quartet, one of the most popular singing organizations in the city.

Returns From Business Trip

John W. Canivan returned yesterday from a business trip to Providence, Fall River and New Bedford, where he found Victor dealers quite encouraged over the way goods are coming along.

Chamberlain Visits Steger Factory

A. W. Chamberlain, manager of the Iver Johnson Sporting Goods Co., recently returned from a trip to the Steger factory.

Brunswick Records Gain in Favor

There has been a big run on the Brunswick records and the new list containing fourteen numbers is being eagerly scanned by those who have become convinced of the high merit of these records. "Swanee" is proving one of the

**PERFECTION BALL-BEARING TONE ARMS**  
**PERFECTION FLEXI-TONE REPRODUCERS**



**Manufacturers—** The Perfection Flexitone reproducer No. 7 attached to the Perfection ball-bearing tone arm No. 4 plays all lateral cut records on all types of Edison Disc Machines. Made in nickel and 24 carat gold finish, extra fine quality disc.

**Jobbers—**

**Dealers—**

These reproducers and tone arms are the very finest made, mechanically—reproducing as the records were recorded in the recording room—Clarity of sound with great volume.

WRITE FOR QUANTITY PRICES

Manufactured by

**New England Talking Machine Co.**  
*Largest Manufacturers of Phonograph Accessories*  
**16-18 BEACH STREET BOSTON, MASS.**  
*Pacific Coast Distributor: WALTER S. GRAY*  
942 Market St., San Francisco, Cal.  
**Phoenix Trading Co., 1265 Broadway, New York**  
Eastern and Export Office

most popular hits in the Brunswick list and it is difficult to keep enough of these records in stock. A forthcoming artist to be heard in

the May list of the Brunswick catalog is Theo. Karle, tenor, and anticipating his records there was a recital by him in Jordan Hall on the evening of April 7, for which a fine program covering a wide variety of songs was arranged.

Returns From Western Trip

H. Leon Sharmat, of S. W. Sharmat & Son, who handle the Vitanola for this territory, has just returned from a trip taken as far West as Chicago, where he went to secure larger consignments of Vitanola machines. On his way home he stopped off at Buffalo and New York for a day or two to meet some of his Harvard classmates.

**CRESSEY & ALLEN**



Portland  
**COVERS**  
New ENGLAND  
CONN. RI.

**The SPIRIT of SERVICE**  
prevails throughout our  
**ORGANIZATION**  
**CRESSEY & ALLEN**  
Victor Distributors  
**PORTLAND MAINE**

**REMEMBER**  
IF IT'S A  
*Phonograph, Accessory or*  
*Repair Kit, WE HAVE IT*  
Full line of  
*Needles, Motors, Tone Arms,*  
*Attachments, Main Springs,*  
*Repair Parts and other Accessories*  
*always in stock*

We are in a position to serve you  
Write for our latest Monthly Bulletin  
**Phonograph Supply Co.**  
of New England  
Court Square Boston, Mass.

Send for Descriptive Circular

*Curry* **DEMONSTRATION BOOTHS**  
**AND RECORD CASES**  
IN STOCK OR TO ORDER

"SOUND PROOF"

FRANK B. CURRY  
72-74 Oedham St. Boston, Mass.



## New England Dealers!

We have a most unusual plan of financing your phonograph department

*Write for Particulars*

New England Phonographs

Empire Phonographs

### New England Piano and Phonograph Co.

*Largest Distributors of Phonographs in New England*

405 Boylston St.

Boston, Mass.

#### THE VICTROLA IN AMERICANIZATION

An Elaborate Booklet on This Particularly Timely Subject Just Issued by the Victor Talking Machine Co.—Of Great Value

There has just been issued by the Victor Talking Machine Co. a carefully compiled and most valuable booklet covering the question of "The Victrola in Americanization," a subject that is of such vital and widespread interest just now. The booklet, with a foreword by Mrs. Frances E. Clark, director of the Educational Department of the Victor Co., was designed especially for the guidance of those engaged in Americanization work in community centers, night schools, continuation schools, Y. M. C. A.'s, Y. W. C. A.'s, social service, etc., and wherever the attempt is being made to mold the foreign born into good citizens.

The booklet is divided into various sections, the first being "The Victrola and Americanization," wherein the subject is discussed at considerable length, and the national and folk songs of a score or more of the foreign nations listed. Next comes "Community Singing in Americanization," with special reference paid to what may be described as the folk songs of America, including "My Old Kentucky Home," "Old Black Joe," "Battle Hymn of the Republic," etc., and then "Folk Dancing in Americanization."

A particularly interesting section is that devoted to "The Victrola in the Study of American History," with special reference to music representative of the various stages of the coun-

try's development, from the landing of the Norse about 900 years ago to the period of the great World War, which is represented by the two wonderfully popular numbers, "Keep the Home Fires Burning" and "There's a Long, Long Trail."

This interesting booklet is copiously illustrated and should be in tremendous demand with educators generally as soon as brought to their attention by the Victor dealers.

#### OPENS NEW STORE IN FALL RIVER

FALL RIVER, MASS., April 5.—Kaplan Brothers have just opened a new store in this city and the interior is of so highly artistic a character as to make the shop one of the handsomest in this city. There are twelve demonstration booths, all finished in a way to make them comfortably inviting. On the opening day the firm distributed little Victor dogs to its customers, which made quite a hit. The establishment features Victor and Columbia talking machines and records and music rolls.

#### NEW DEALERS IN MASSACHUSETTS

The list of Aeolian-Vocalion dealers in Massachusetts is growing steadily to a point where that territory is well covered. Among the dealers recently appointed by the Aeolian Co. to handle the Vocalion are the Bahr Piano & Music Co., Quincy, Mass.; Timothy J. Buckley, Lawrence, Mass., and E. W. Ladd, Marlboro, Mass.



## YOU Specify The Equipment

We will install the kind of motor, tone-arm, reproducer or accessory you want; and deliver you this splendid machine fully equipped, in the finish and with the trimmings you like best.

#### We Can Make Prompt Deliveries

*Watch The Talking Machine World for our big offer each month. Something you have been looking for.*

**SINGER**  
Talking Machine Co.

579 Market Street

MILWAUKEE, - - WIS.

## Lansing Khaki Moving Covers

Despite the obstacles that have arisen during the past year have maintained their high standard of

### QUALITY

The Quality of the LANSING cover has given it leadership in the field



No. 3 Carrying Strap Shown in Cut

These covers are made of Government Khaki, interlined with heavy felt in Grade A, or cotton in Grade B, fleece lined, quilted and properly manufactured under the personal supervision of E. H. Lansing, the originator of the Talking Machine Cover for protection in moving. Made in two grades.

*Write for prices and descriptive catalogue*

**LANSING COMPANY**  
611 Washington St., BOSTON

San Francisco Representative: WALTER S. GRAY  
942 Market Street  
PHOENIX TRADING COMPANY  
1265-69 Broadway, New York



# Lundstrom

## CONVERTO

PATENTED DEC. 11, 1917

### Talking Machine CABINET



One of the advantages of the Converto is that the Portable Victor that fits into it *remains* portable. People who want a machine which they can easily move to other parts of the house, out on the porch, into the garden or summer house, and about vacation camps and bungalows, may still have a neat cabinet and record file for it in its more usual place.

**The C. J. Lundstrom Mfg. Co.**  
LITTLE FALLS, N. Y.

*Lundstrom "Converto" Cabinets are broadly covered by patents. Infringements will be promptly prosecuted.*

## Converto Wholesale Distributors

Albany, N. Y. .... Gately-Haire Co., Inc.  
Atlanta, Ga. .... Elyea Talking Machine Co.  
Phillips & Crew Piano Co.  
Baltimore, Md. .... Cohen & Hughes, Inc.  
E. F. Droop & Sons Co.  
Birmingham, Ala. .... Talking Machine Co.  
Boston, Mass. .... Eastern Talking Machine Co.  
Buffalo, N. Y. .... W. D. & C. N. Andrews  
Burlington, Vt. .... American Phonograph Co.  
Chicago, Ill. .... Lyon & Healy  
Cincinnati, Ohio. .... Rudolph Wurlitzer Co.  
Cleveland, Ohio. .... Cleveland Talking Mach. Co.  
The Eclipse Musical Co.  
Columbus, Ohio. .... The Perry B. Whitsett Co.  
Dallas, Texas. .... Sanger Bros.  
Denver, Colo. .... The Knight-Campbell Music Co.

Des Moines, Ia. .... Mielke Bros. Co.  
Elmira, N. Y. .... Elmira Arms Co.  
El Paso, Texas. .... W. G. Walz Co.  
Houston, Texas. .... The Talk. Mach. Co. of Texas  
Jacksonville, Fla. .... Florida Talking Machine Co.  
Kansas City, Mo. .... J. W. Jenkins' Sons Music Co.  
Schmelzer Arms Co.  
Memphis, Tenn. .... O. K. Honck Piano Co.  
Milwaukee, Wis. .... Badger Talking Machine Co.  
Mobile, Ala. .... Wm. H. Reynolds  
Newark, N. J. .... Collings & Company  
New Orleans, La. .... Philip Werlein, Ltd.  
New York City. .... Emanuel Blout  
Cabinet & Accessories Co., Inc.  
Knickerbocker Talking Machine Co.  
Omaha, Nebr. .... Mielke Bros. Co.

Pearia, Ill. .... Putnam-Page Co.  
Philadelphia, Pa. .... C. J. Hepp & Son  
The Geo. D. Ornstein Co.  
Penn Phonograph Co.  
H. A. Weymann & Son, Inc.  
Pittsburgh, Pa. .... W. F. Frederick Piano Co.  
Standard Talking Machine Co.  
Portland, Me. .... Cressey & Allen, Inc.  
Providence, R. I. .... J. Samuels & Bro., Inc.  
Richmond, Va. .... The Corley Co., Inc.  
St. Paul, Minn. .... W. J. Dyer & Bro.  
San Francisco, Cal. .... Walter S. Gray Co.  
Sioux Falls, S. D. .... Talking Machine Exchange  
Syracuse, N. Y. .... W. D. Andrews Co.  
Toledo, Ohio. .... Toledo Talking Machine Co.  
Washington, D. C. .... Cohen & Hughes, Inc.  
E. F. Droop & Sons Co.



NEW FOREIGN RECORD CATALOGS

Up-to-the-Minute Listings of Victor Records in Twelve Foreign Languages Now Available—The Value of Foreign Record Business

New foreign catalogs listing Victor records in the following twelve languages have been issued by the Victor Talking Machine Co. and are being distributed to the trade through the wholesalers: Armenian, Bohemian, Cuban, Danish, Finnish, French, Hebrew, Italian, Mexican, Norwegian, Polish and Swedish. Others are available in Arabian, Croatian, Dutch, Greek, Lithuanian, Portuguese, Porto Rican, Roumanian, Russian, Ukrainian, Serbian, Slovak.

In connection with the featuring of foreign records, the Victor Co. makes some timely comments as follows:

"There is no reason in the world why every Victor dealer should not handle a foreign record business. There is plenty of money in it. All that's necessary is to make known the fact that you carry foreign records in stock. And one of the best ways to bring about this object is to get these foreign catalogs into circulation.

"The first thing, of course, is to find out what nationalities are included among the foreign population of your city, and then order catalogs in those languages. Get one into the home of every foreigner in town, for they all love music and the catalog listing the music of their native land will be as welcome as it would be to you in a far country. And printed matter is not a drug on the market with the foreigner; it's something of a novelty.

"Foreign catalogs serve a double purpose—not only do they list all the foreign records in the particular language, but they contain illustrations of some of the most popular type Victrolas and prices of the entire line.

"Possibly you have not gone after this business because of your inability to speak any foreign language. This difficulty is not insurmountable. Suppose, for instance, the foreign element of your town is composed largely of Swedes, with quite a sprinkling of Norwegian, Danish and Finnish people. These four languages are all very similar in character and they constitute what may be called a national group of tongues. There are other groups, especially the Bohemian and Hungarian group, the Italian group of dialects, the Russian, Polish, Ukrainian group, etc. Generally speaking, a resident familiar with one language of a group will know the others."

The Period Tone Arm Corp. has incorporated with a capital of \$10,000 and the incorporators are: M. Borris, A. Rabinowitz and D. Goldenberg, 148 Amherst street, Brooklyn, N. Y.

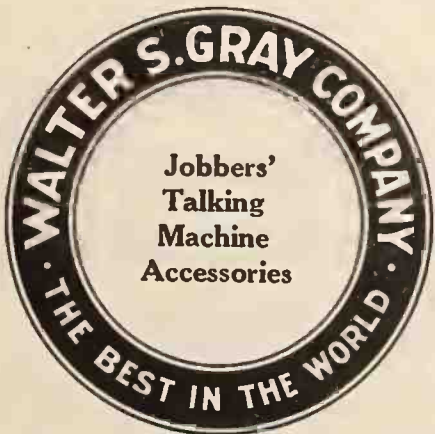

NEEDLES

and The Best in the World in Talking Machine Accessories AND

United States Music Co. Player Rolls

The retail price of these rolls runs from fifty cents to one dollar each. Your discount 40% f. o. b. San Francisco.

942 Market St., San Francisco, California

CONDON & CO. REPRESENT SHERMAN-CLAY IN NEW YORK

Sherman, Clay & Co., the Great Pacific Coast Music House, Appoint Condon & Co. as Their Representatives in the Metropolis—An Important Arrangement of Mutual Advantage

It was announced recently that Sherman, Clay & Co., San Francisco, Cal., had appointed Condon & Co., Inc., 200 Fifth Avenue, New York, their Eastern representatives. This important deal was closed a few weeks ago when Wm. A. Condon, head of the company bearing his name, visited the Pacific Coast.

Sherman, Clay & Co. have manifold interests in the East, all of which will be in the hands of Condon & Co. One of the most important Eastern activities will be the sale of the mechanical reproduction rights for the compositions published by Sherman, Clay & Co. to the manufacturers of talking machine records and player rolls. During the past few years this famous house has published many compositions that have achieved countrywide success, and Condon & Co. will devote a considerable part of their time to handling the details incidental to the

reproduction of these compositions on rolls and records. All necessary details pertaining to the shipment of pianos, player-pianos, etc., from New York to the Pacific Coast will be handled by Condon & Co. in conjunction with their other activities as Eastern agents.

This important deal marks another step in the signal success of Condon & Co., which was formed less than a year ago by Wm. A. Condon, who is one of the best known members of the talking machine industry. During the past few months, Condon & Co. have built up a profitable demand for all of their products, and under Mr. Condon's able guidance have laid the foundation for a permanent business that is steadily increasing.

The Morgan Music Co., Murphysboro, Ill., has just enlarged its record department.

Advertisement for The SCOTFORD Tonearm and Superior Universal Reproducer. Includes images of the tonearm and reproducer, descriptive text, and a testimonial from Frank D. Perry.

The SCOTFORD Tonearm and Superior Universal Reproducer

"WE ATTRIBUTE a large part of our success to the improvement in our machine from the first Scotford Tonearm received from you. We are positively satisfied, and our only fear is that in the face of the multitude of competition temporarily on the market you may try in some way to cheapen to meet this. DON'T DO IT! The writer has been connected with "tone" all his life—and you have it"

Frank D. Perry—Hudson, New York

The Scotford Tonearm and Superior Universal Reproducer will not be cheapened. We know that the field is amply filled with Tonearms and Reproducers that sell on price. We are serving that better class of trade which is building on quality. They appreciate the fact that only those who build the Phonograph as an Instrument of Music will survive the tests of time.

Table with 2 columns: Item, Price. Rows include Sample Set with Black Composition Diaphragm (\$8.50 Nickel, \$10.50 Gold) and Extra Reproducer with Mica Diaphragm (5.75 Nickel, 6.75 Gold).

Quantity Prices on Application

Barnhart Brothers & Spindler

Makers of Superior Specialties for Phonographs



Monroe and Throop Streets Chicago, Illinois



# PHILADELPHIA SHOW CASE COMPANY

127 North 13th Street

Philadelphia, Pennsylvania

Pittsburgh Branch: 2002 Jenkins Arcade Building

*WHOLESALE DISTRIBUTORS*

---

*Come in With Us  
Okeh Record Dealers  
and be Assured of  
Real Record Service*

We have a live wire sales organization, thoroughly experienced in merchandising from all angles of the phonograph business and we're all set, just waiting for the pass-word, to give you our co-operation and help you develop a profitable business in

## Okeh Records

The Okeh library comprises the most popular hits of the day recorded by the most popular artists. Musically these records are the best on the market, and represent the acme of perfection.

*A New Complete Catalog  
of the Latest Okeh Records—Now Ready*

**WE HAVE THEM**



# The Trade in PHILADELPHIA and LOCALITY

PHILADELPHIA, PA., April 7.—The talking machine business continues to move apace and with a rapidity that is most gratifying to every one engaged in the business, whether it be the jobber, the retailer, or both, for there is activity in every line. In March the talking machine factories gave a splendid account of themselves, sending both machines and records to this city in quantities larger than they did at any time within the past fifteen months.

From the retail standpoint the first two weeks of March were very satisfactory, but the Easter preparations butted in the last two weeks to put a little crimp in the selling, and then a great many people were preparing for their April "fitting" and still more were concerned about the payment of their income tax, as on the whole it threw the talking machine business as well as every other business of a like character out of joint. But this did not seem to disturb the dealers very much for they realized that it was merely a repetition of what had been the condition just prior to Easter for the past few years.

Everyone in the trade here believes that this Spring is going to see an unusual business, with the factories in such shape that they will be able to supply all the needed machines and records.

#### Emerson Dealers to Meet in Convention

An event of unusual interest for Philadelphia is the announcement that the Emerson dealers will hold the first convention yet held by dealers in these popular records in this city on May 7. If it is successful similar meetings will be held in every section of the country. The sessions will be held in the auditorium of the Parkway Building, in which the Emerson Philadelphia Co. occupies almost the entire third floor. The

entire personnel of the Emerson Co. will be here, including Victor J. Emerson, the founder and president of the Emerson Co.; H. T. Leeming, vice-president and general manager; Arthur H. Cushman, director of sales; Joseph I. Carroll, manager of sales; Arthur Bergh, director of recordings, and Paul F. Wiggin, manager of advertising.

#### Cantor Publicity Week

Another interesting item in connection with the Emerson here is the extensive preparation that Manager Fox, of the Emerson Philadelphia Co., has been, and is, making for the coming visit of Eddie Cantor. There is going to be a Cantor week here the week of May 3 and each day there will be special advertising features. Manager Fox is going to try to outdo all other Emerson branches in his Cantor publicity week.

#### Closed Big Record Business

The Emerson Philadelphia Co. report that its business has been very good all through March. Mr. Fox has just been to New York, and had a chance to see and examine the new Emerson machine, shortly to be placed on the market. He says that it has really gone much beyond the mark that he had set for the Emerson phonograph. "If we can get deliveries," he says, "I feel sure that we will be able to put them in the very best stores in this city and secure our full share of representation."

O. W. Ray, of the Emerson Phonograph Co. executive office, is at present covering eastern Pennsylvania with William D. Neff, and from the reports that Mr. Neff is sending in they must have been able to secure the very best accounts in the various towns visited.

#### Returns From Honeymoon

George Gewehr, who was recently married,

has returned to his Wilmington home from his honeymoon trip spent in Florida with his bride. The Benedict beam on his countenance, say those who have seen him at his West Ninth street store, is beatific.

#### T. W. Barnhill Back From Coast Trip

T. W. Barnhill, of the Penn Phonograph Co., is expected home on Saturday of this week from close to two months' absence. He journeyed by way of the Southern route to the Pacific Coast and returned by the Northern route after visiting all the places of interest. He was accompanied by Mrs. Barnhill and reports that it was a most delightful trip and that he is returning fully rested.

#### Conditions With the Penn Co.

The Penn Co. reports that business was a little quiet the last week, but not more so than, if as much as, last year. It is selling all the goods it can get, and remarked that the advance in Victor prices has not in any way affected business. M. Roce, manager of the Benesch & Sons Co., of Pottsville, was a Penn visitor last week.

#### Peerless Record Makers in Concert

"The Peerless Record Makers," a concert company made up of some of the best talent of the Victor Co., gave a concert in this city at the Academy of Music on the evening of Tuesday, April 6, under the management of Philip W. Simon, a Victor dealer in Uniontown, Pa. It was a great success and helped local record business.

#### Weymann Tells of Active Demand

H. A. Weymann & Sons report that their talking machine business in March, like every other department in their store, went way ahead of last year. H. W. Weymann says:

(Continued on page 96)

## 500 PENN-VICTOR-DOGS

(WITH YOUR NAME CAST IN PEDESTAL)

IN 500 HOMES  
ARE 500 BOOSTERS *for you*  
NOT FOR AN HOUR  
NOT FOR A DAY  
*But PERMANENTLY*  
DO YOU GET THE VISION?

Order Penn Victor Dogs NOW for Your Spring Windows

**PENN PHONOGRAPH CO., Inc.**  
913 Arch Street, Wholesale Only—Victor Exclusively Philadelphia

#### PENN-VICTOR DOG DISTRIBUTORS

- |   |  |
|---|--|
| Atlanta, Ga.....Elyea Talking Machine Co.           | Minneapolis, Minn.....Beckwith-O'Neill Co.       |
| Baltimore, Md.....Cohen & Hughes.                   | Mobile, Ala.....Wm. H. Reynolds.                 |
| Birmingham, Ala.....E. F. Droop & Sons Co., Inc.    | New Haven, Conn.....The Horton-Gallo-Creamer Co. |
| Boston, Mass.....Talking Machine Co.                | Newark, N. J.....Collings & Co.                  |
| .....Oliver Ditson Co.                              | New Orleans, La.....Phillip Werlein, Ltd.        |
| .....Eastern Talking Machine Co.                    | New York City.....C. Bruno & Son, Inc.           |
| .....The M. Steinhilber & Sons Co.                  | .....Knekerbocker Talking Machine Co.            |
| Burlington, Vt.....American Phonograph Co.          | .....New York Talking Machine Co.                |
| Butte, Mont.....Orton Bros.                         | .....Ormes, Inc.                                 |
| Chicago, Ill.....Chicago Talking Machine Co.        | Philadelphia, Pa.....H. A. Weymann & Sons        |
| Cleveland, Ohio.....Cleveland Talking Machine Co.   | Pittsburgh, Pa.....W. F. Frederick Piano Co.     |
| .....The Eclipse Music Co.                          | Portland, Me.....Cressey & Allen, Inc.           |
| .....The Knight-Campbell Music Co.                  | St. Louis, Mo.....Koeber-Brenner Co.             |
| Denver, Colo.....W. G. Walz                         | Toledo, O.....Toledo Talking Machine Co.         |
| El Paso, Texas.....Stewart Talking Machine Co.      | Washington, D. C.....Cohen & Hughes.             |
| Indianapolis, Ind.....Florida Talking Machine Co.   | .....E. F. Droop & Sons' Co.                     |
| Jacksonville, Fla.....J. W. Jenkins' Sons Music Co. | .....Robt. C. Rogers Co.                         |
| Kansas City, Mo.....O. K. Houck Piano Co.           |  |
| Memphis, Tenn.....Badger Talking Machine Co.        |  |
| Milwaukee, Wis.....Badger Talking Machine Co.       |  |





# Mother Machree of A. C.

Mother Machree and Walter Scanlan are great favorites in Atlantic City and vicinity—just as they're great favorites *everywhere*.

Walter Scanlan sings for many of the "first families" of Eastern Pennsylvania and Southern New Jersey. Not personally, of course, but via Emerson Standard 10-inch Gold Seal Records.

Wherever the hit's the thing, you'll find Emerson Records putting joy in life.

Our job is to supply these much-wanted records to dealers handling the Emerson line.

We hope that includes you. If it doesn't, the adjustment is easily made. Write us at once.



## Emerson Philadelphia Co.

Parkway Building

BROAD and CHERRY Streets -:- PHILADELPHIA, PA.

Distributors of EMERSON RECORDS

### THE TRADE IN PHILADELPHIA AND LOCALITY—(Continued from page 95)

"There has been no let up in the demand for Victrolas and Victor records, and this department of our business has been kept busy every minute of the day during the business hours." They have been able to very nearly supply all of their back orders.

#### Wilkinson With Cheney

G. Dunbar Shewell, the representative here of the Cheney, states that he is still short of machines, and that the demand continues to be greater than the increase in production. He has secured C. J. Wilkinson, who was formerly connected with G. A. Barlow's Sons Co., of Trenton, N. J., as a salesman to cover his territory.

J. G. Widener, of Boston, visited the Widener Columbia house here the past week.

#### Busy Times With Buehn Co.

Louis Buehn, of the Louis Buehn Co., reports that its business in March was as active as could be expected for the season and better

than it was last year, limited, naturally, to the amount of stock being received. This month, however, is increasing in a satisfactory way right along. Mr. Buehn says the future outlook is encouraging. Although there has been considerable comment by the dealers regarding the increase in Victor prices, yet, he says, they are more concerned about getting machines than they are about being able to dispose of them. He holds that the dealer in the Victor believes that he can sell all the machines he can get his hands on, and at any price. During the month Mr. Buehn attended jobbers' conventions in Chicago and New York City.

#### Purchase Their Own Buildings

T. Connell, the Victor dealer at 2633 West Girard avenue, has purchased the building he has occupied for some time, and is about to make extensive alterations which will include the installation of ten additional hearing rooms.

Charles E. Robertson has also purchased the building he has occupied for several years at 3851 Lancaster avenue, and is also going to make extensive alterations, including the addition of a number of hearing rooms. John T. Gallagher, of 4066 Lancaster avenue, will be compelled to vacate shortly and will move to a new building which he has just purchased at 4226 Lancaster avenue.

Herman Cole, talking machine dealer at 6018 Market street, who had been ill for a number of weeks, is again able to attend to business.

Clement Beecroft, the talking machine accessory man of 5546 North Fifth street, is considerably improving his new display rooms. He is erecting six hearing rooms and is operating as an exclusive Victor dealer.

#### The Brunswick in Atlantic City

C. P. Chew, the distributing representative

(Continued on page 98)



## Superior Service in Vitanola Talking Machines

OUR TERRITORY COVERS

EASTERN PENNSYLVANIA, NEW JERSEY AND DELAWARE

If you are in this territory it will pay you to write for information regarding an agency for this progressive line

VITANOLA DISTRIBUTORS COMPANY

1025 ARCH ST.

E. F. MARTIN, President

PHILADELPHIA, PA.

HELL PHONE, WALNUT 1383

KEYSTONE PHONE, RACE 5913-D



# A Business Organization

---

## *Equipped for Big Business*

---



\$125,000. Building  
Investment *for*  
**VICTOR**  
Wholesaling  
Exclusively

Ample and Available Capital  
for the Purchase and Storage  
of Big VICTOR Stock

An Organization of Character  
and Ability

Dependable VICTOR Service  
to Dealers Whose Methods  
Rate VICTOR Service

A Business Program — Big  
in its Vision — Working for  
the Better Interests of Our  
Dealers

**THE LOUIS BUEHN COMPANY**  
OF PHILADELPHIA

*Exclusive Wholesale Victor Distributors*



THE TRADE IN PHILADELPHIA AND LOCALITY—(Continued from page 96)

The greatest combination in the Musical Industry for the dealer to acquire permanent prestige and success.

VICTROLAS AND VICTOR RECORDS

**Q · R · S**  
PLAYER ROLLS

WEYMANN "KEYSTONE STATE" String Musical Instruments and specialties bearing the "W. & S." label.

Dealers in placing orders with us for their requirements have the advantage in obtaining from all three departments in one delivery goods that are unquestionably superior and best known to the entire industry.

*If you have not received our special stock list and order blank, write us*

Manufacturers  
and Wholesale  
Distributors

**WEYMANN**

Established 1864

1108 Chestnut Street  
Philadelphia, Pa.

here of the Brunswick, reports that things are coming in a little better than formerly, but not "good enough by any means," for he has been unable to accept any new representatives, in spite of the many who are clamoring for admission into the Brunswick family. Mr. Chew was recently visited by Edward Strauss, of the New York Brunswick office, and Mr. Loesch from the Baltimore branch. The Endicott Furniture Co., extensive handlers of furniture at Atlantic City, on May 1 will open an exclusive Brunswick department in their store, and are preparing for it by the erection of a number of Unico booths and a large record room.

#### New Booths for Friedenburg

S. Friedenburg, the proprietor of the Philadelphia Talking Machine Co. at present at 809-11 Chestnut street, has recently built a large office at the eastern side of his wareroom and has erected two additional booths. He has been meeting with very good success in the handling of the Modernola, an attractive circular cabinet machine which is made in Johnstown, Pa.

#### Edison Dealers Plan Meeting

The Philadelphia Edison dealers are arranging for a meeting to be held here on the second Tuesday in April at the Bingham House, at which a number of new Edison policies will be explained to the dealers.

Mr. Waltz, for a number of years connected with the Victor Co., but at present with Cohen

& Hughes, Baltimore, was a recent Philadelphia visitor, where he has many friends.

#### Activities of Columbia Co.

The Columbia Co. has been enjoying an excellent business in March. It is getting stock through in great quantities, both records and machines, and is keeping its dealers very well supplied. Auditors from the New York offices have been here several weeks in March, Messrs. Smediken and Monroe. Mr. Lynch, of Bridgeport, Conn., was a recent visitor, also Charles J. Stone of the record service department who is devoting special attention to foreign record service.

#### Preparing for Local Columbia Meeting

The local Columbia branch is preparing for a big dealers' meeting in Philadelphia shortly to which will be invited all the dealers in this city and adjoining territory. The Big Four of New York—Messrs. Hopkins, Tuers, Benz and Bolton—will be present, and each will address the dealers on subjects that will be sure to be of great interest to them as well as advantage in their business. Recent Columbia visitors were Mr. Grim, of the Regal Umbrella Co., of York, Pa.; Mr. Kades, of Miller & Kades, Harrisburg, Pa., and John Wuchter, of Allentown, Pa.

The Dictaphone section of the Columbia, which is in charge of C. A. Malliet, has had a very good business in March, much better than the same month of last year. W. C. Kabin, of

## DECALCOMANIA

Name Plates for Talking  
Machines, Pianos, etc.

High Class Workmanship

*Write us for further information*

**National Decalcomania Co.**

220-230 N. 60th St., Philadelphia, Pa.

the New York offices, was a recent visitor. Mr. Malliet has added several new salesmen to his outside force. The department is preparing an elaborate display for the annual Business Show which is to take place here the week of April 19.

#### To Attend Salesmanship Course

Jacob Sitnek, of Altoona, accompanied by two young ladies from his record department, came to Philadelphia ten days ago, the ladies to enter the salesmanship course of the Victor and Mr. Sitnek to see that they were properly housed.

#### Buys Fitch & Lamb Store

Joseph Freed, of Pittston, Pa., has purchased the talking machine business in that city of Fitch & Lamb, and is adding a number of new booths and otherwise improving the warerooms.

#### New Pathé Representative

The local retail Pathé business has been very brisk all month, and, while the Interstate Phonograph Co. has been getting liberal shipments of machines, it is still considerably behind in orders of some types. Walter Eckhardt, the general manager, does not believe that the increase in Pathé prices that has recently gone into effect is going to in any way interfere with the demand. The latest from here to take on the Pathé is the Derbyshire Brothers, who have a fine store at 2418 North Front street. A recent visitor to the Pathé offices was L. A. Sterchi, of Sterchi Bros. & Co., of Bristol, Tenn. This firm has a chain of stores in that section.

#### The Demand for Okeh Records

A. J. Heath, the Philadelphia Okeh man, says that while he found a little let up in the business the end of March, he believes that April is going to show up very big, and that there is going to be a phenomenal business during the

#### MOTORS—TONE ARMS

Double spring motors, complete, including 12 in. T. T. samples \$5.00, dozen lots \$4.50, 100 lots \$4.25. No. 6 tone-arm and reproducer, first quality, samples \$3.75, dozen \$3.50. No. 7 tone-arm and reproducer, best, samples \$5.50, dozen \$5.25.

#### EVERYBODY'S TALKING MACH. CO.

Authorized Distributors  
Heineman & Melsselbach Motors  
38 N. 8th Street, Philadelphia, Pa.

**F**OR the progressive dealer who likes to be known for the quality of his goods, who is constantly seeking to increase the prestige of his name, we have a real contribution to offer.

On our floors we have thirty custom-built Solotones in period designs, finished in mahogany and walnut. These impressive phonographs measure nearly 60" over all, and are of distinctive design and finish. They will be sold to dealers who appreciate the value of an art phonograph as a beautiful display piece.

*F. P. Allenian*

SOLOTONE MANUFACTURING CO.

PHILADELPHIA, PA.



THE STEEL NEEDLE WITH THE GOLD FINISH

# MAGNEDO

EACH NEEDLE GUARANTEED TO PLAY 10 RECORDS

**“The Original and Fastest Selling Multi-Playing Needle”**

Retails at 10c per box of 50

“You Can Sell **More** Magnedos **Easier** Than Any Other Brand of Needle.”

**Extra Loud, Loud and Medium**



### PACKING

Our Attractive 2-Color Display Carton Sells the Needles on Sight.

### ADVERTISING

**Magnedos** are well known all over the country. There is a ready market for them.

### PROFIT

Costs \$3.90 per Carton  
**54%** Profit  
Liberal Discounts to Jobbers

## Magnedo Means Profit

### ORDER NOW!

We have distributors in every big city ready to supply you. Send us your order on this coupon and we will forward it to your nearest jobber for his prompt attention.

#### COUPON ORDER BLANK

Please ship.....cartons

To.....

Via..... City.....

Supertone Needle Works, 23 W. 19th St., N. Y.







**THE TRADE IN PHILADELPHIA**  
(Continued from page 98)

Spring. He has not been able to get enough Okeh records to supply the demand. W. C. Fuhri, general sales manager of the General Phonograph Corp., was recently here, accompanied by his assistant, R. S. Peer. Another visitor was Mr. Stanton, manager of the dealers' service department. Mr. Fuhri had just returned from a trip through the West, and he says that the Okeh records are meeting with a big demand in that section. L. M. Huggins has been added to the sales force of Mr. Heath's establishment.

**Growth of United Music Stores Business**

The United Music Stores, at 1124 Walnut street, report considerable success with the Lyric records, for which they have exclusive jobbing rights in this city. Their dealers report that these records are giving considerable satisfaction and the United Music Stores are organizing their facilities to provide the maximum service in supplying these records. The United Music Stores have also been distributors in

Philadelphia for Connorized music rolls for a long period and have made these rolls popular throughout the Quaker City.

O. Kearns, head of the organization, who is also the president of the Music Roll Dealers' Association in this city, is an enthusiast on service and protection for the dealer. In speaking recently with The World he attributed the success of his company to the fact that it has co-operated with the dealer and did not appoint nearby

competitors in any locality. Mr. Kearns is optimistic over prospects for the future and predicts that the volume of business both in records and music rolls will be tremendous. The company has already outgrown its once ample quarters and plans are on foot to secure a building with four times the present facilities.

O. Kearns, president of the United Music Stores, distributors in this city of Lyric records and Connorized music rolls, announces that George F. Fields is now connected with the United Music Stores. The latter has long been associated with the music trade as a dealer in this city, and in his new connection he will be manager of the Lyric record department.

**Take on the Cirola Line**

The firm of N. Stetson & Co., long exclusive handlers of Edison phonographs and records, have added the Cirola machine, which is made by the Cirola Phonograph Co. of Philadelphia. The Stetson department is in charge of Luke Moore, with Katharine Funcheon as his assistant.

**EXPANSION OF STERN CORPORATION**

**Celebrates Fourth Anniversary with Eclat—Increase Capital From \$100,000 to \$200,000**

SAN FRANCISCO, CAL., April 5.—The Stern Talking Machine Corp. of this city celebrated its fourth anniversary last Saturday, and the executives of the company received messages of congratulations from the trade in all parts of the country. The business of the Stern Talking Machine Co. has grown by leaps and bounds, until now, at the completion of its fourth year in business, the volume of sales compares favorably with the figures of the most successful retail concerns in the industry.

During the past few weeks the Stern Talking Machine Co. has received several car loads of phonographs and five car loads of records, constituting one of the largest shipments ever received by any member of the trade in the Far West. The Stern Talking Machine Co. attributes a considerable measure of its success to its systematic campaign of advertising in the columns of the daily newspapers of San Francisco, Oakland and Richmond. The company recently increased its capitalization from \$100,000 to \$200,000 in order to accommodate its fast growing business.

**VISITING CHICAGO HEADQUARTERS**

Geo. A. Kelley, head of the record ordering department of the New York Talking Machine Co., Victor wholesalers, left recently for Chicago, where he will spend ten days at the headquarters of the Chicago Talking Machine Co., Victor wholesalers.

**LYRIC RECORDS**

The Lyric records are lateral cut and will play on any machine. New issues March 1st, 1920. Write for catalogs and discounts

**UNITED MUSIC STORES**

1124 Walnut Street

Philadelphia, Pa.

Exclusive Philadelphia Jobbers of

**LYRIC RECORDS**

**CONNORIZED MUSIC ROLLS**

**The Franklin**

A PHONOGRAPH OF DISTINCTION



LOUIS XVI

You can dance or play the most delicately shaded selections with equal satisfaction on the New Franklin, as we have at last combined volume and tone in the new horn or tone chamber of the Franklin.

When do you want your sample shipped?

**The Franklin**

**Is Different**

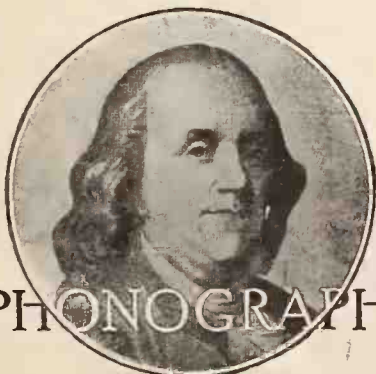

**FRANKLIN PHONOGRAPH COMPANY**  
INCORPORATED

10th and Columbia Ave.

PHILADELPHIA, PA.

NEW YORK OFFICE — 253 West 42nd St., New York City

WM. RASHALL, Manager

**REPAIR PARTS**

For All Machines  
New or Obsolete

ALSO

**QUALITY MOTORS**

TONEARMS, REPRODUCERS

**The Val Accessory House**

1000-1002 Pine Street  
St. Louis, Mo.





Crimi

Peterson

Raisa

Easton

Rimini

## THE NEW VOCALION RECORD

*Lateral Cut, Playable on All Standard Machines*

THE development of the phonograph has been one of the most interesting and far-reaching events in musical history.

The phonograph and the phonograph record are practically one—that is, neither is of value without the other. An improvement in either directly affects both. While this is true, however, the most obvious improvements in recent years have been connected with the instrument. A notable illustration of this is furnished by the *Aeolian-Vocalion*, which is recognized both here and abroad as representing a definite and decided advance in phonograph construction.

It is significant that from the source that produced this new phonograph should emanate a Phonograph Record of improved type.

The importance of the New Vocalion lateral-cut Record may hardly be overestimated. To



Nellie

Kous





Dambois



D'Alvarez



Sundelius



Scotney



O'More

the public it means that the most perfect record ever put upon the market is now available for use with all standard phonographs. To the music-trade it means one more vital sales feature added to the many included in the representation of the Aeolian-Vocalion. The new Vocalion Record is a super-record. In true musical quality, in durability, in content and timeliness of issue it is not equalled in the whole phonograph field.

Up-to-date merchants who are not in the phonograph business, and those who are, but are not handling the Aeolian-Vocalion, will see in this new record one more cogent reason for securing Vocalion representation before territory is all assigned.

### THE AEOLIAN COMPANY

NEW YORK · LONDON · PARIS · MELBOURNE · SYDNEY · MADRID

#### DISTRIBUTORS

- |   |   |
|---|---|
| Nordheimer Piano & Music Co., Ltd.<br>Toronto, Canada | Emerald Co. . . Birmingham, Alabama                     |
| The Aeolian Co. . . . . Chicago, Ill.                 | Guest Piano Co. . . . Burlington, Iowa                  |
| The Aeolian Co. . . . Cincinnati, Ohio                | D. H. Holmes Co., Ltd., New Orleans, La.                |
| The Aeolian Co. . . . . St. Louis, Mo.                | O. J. DeMoll & Co., Washington, D. C.                   |
| The Aeolian Co. . . San Francisco, Cal.               | Stone Piano Co.<br>Fargo, N. D., and Minneapolis, Minn. |
| Consolidated Music Co.<br>Salt Lake City, Utah        | R. W. Tyler Co. . . . . Wheeling, W. Va.                |
| B. Dreher's Sons Co. . Cleveland, Ohio                | Vocalion Co. . . . . Boston, Mass.                      |
|   | D. L. Whittle Music Co., Dallas, Texas                  |



Sara

Kouns



# HIGH GRADE MACHINES

## PRICED RIGHT

THE

# WADEROLA



WADEROLA—G25  
Height 50", Width 23", Depth 23"



WADEROLA—A7  
15x17x20½ Inches

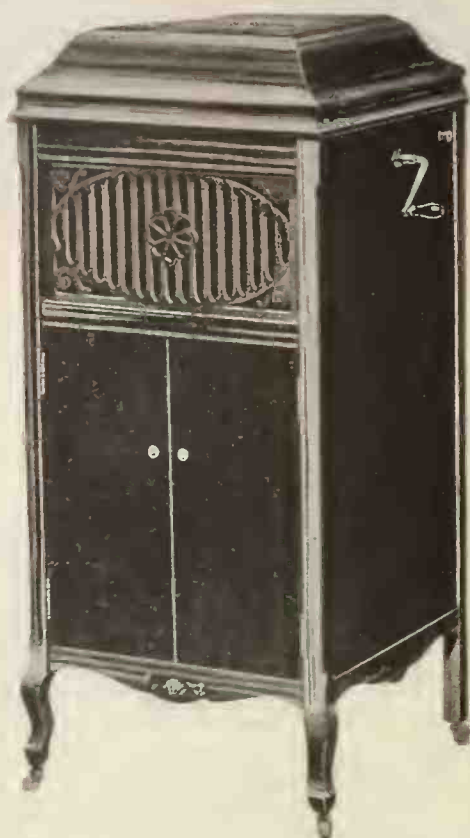

WADEROLA—D16  
Height 48", Width 21", Depth 21"

Write for Catalogue  
and Prices of this  
very Profitable, High-  
grade, Complete Line of  
Phonographs

**BETTER** TONE  
FINISH  
PROFITS

GET  
"WADE"  
SERVICE

# Okeh Records

A PROFIT WINNER

Become  
an authorized Okeh Dealer  
Don't say, "We are just out"  
Get

Wade "Coast to Coast" Service  
CHICAGO DISTRIBUTORS

Anticipate your future  
requirements in all De-  
partments of your Phono-  
graph Business. We are  
in the centre of everything  
We ship promptly

**ANYWHERE**

GET  
"WADE"  
PRICES

## ACCESSORIES—NEW "WADE" BULLETIN

YOU WILL FIND IN OUR NEW BULLETIN EVERYTHING DESIRABLE IN  
ACCESSORIES FOR THE PHONOGRAPH—OUR PRICES WILL SURELY  
INTEREST YOU—DON'T FAIL to WRITE IMMEDIATELY for this BULLETIN

# Wade Talking Machine Co

**WHOLESALE DISTRIBUTORS.**

12-20 NORTH MICHIGAN AVE., CHICAGO



**“Dunque lo Son,” the Barrientos-Stracciari duet from *The Barber of Seville* is such a brilliant aria that you’ll find it hard to keep stocked up. Columbia Record 49612.**

**Columbia Graphophone Co.  
NEW YORK**



**LARGER QUARTERS FOR THE COLUMBIA CO. IN CINCINNATI**

Will Remove to 319-321 East Eighth Street June 1—Chain of Suburban Wurlitzer Stores—Pathé to Establish Jobbing Headquarters—Increasing Aeolian Activity—Huss Bros. Expansion

CINCINNATI, O., April 3.—Announcement has been made that the local branch of the Columbia Graphophone Co. will, some time before June, move to much larger quarters at 319-321 East Eighth street, this city, the lease on the new building having already been signed. The new home of the local branch will be located on the principal automobile thoroughfare of the city and will contain 40,000 square feet of floor space. Division Manager F. F. Dawson of the Columbia house states that he is not yet ready to make a formal announcement of the arrangement of the new building, but there is no doubt that it will be on an elaborate scale.

The building which is occupied by the present branch at 427 West Fourth street, has been leased by the Ohio Talking Machine Co., a new organization of Victor wholesalers which has come into the local field.

The Rudolph Wurlitzer Co. has arranged to open a chain of stores in the suburbs, the first one, already announced, being at 904-906 McMullan street at Peeble's Corner. This new branch will carry a general line of musical instruments and supplies, but will specialize on Victor machines and records.

The Pathé Phonograph Co., through the Park Phonograph Co., Columbus, Ohio, will establish jobbing headquarters in Cincinnati. The district, to include parts of Indiana and Kentucky, will be in charge of E. L. Hanover, formerly of Columbus. Mr. Hanover has already bought a home in this city, but is yet to secure loft quarters. He is searching the market for accommodations to meet his requirements, desiring at least 5,000 square feet of floor space.

Geo. H. Link, one of the oldest Victor merchants in Cincinnati, is also going to carry a line of Columbia supplies. In order to do this

he has leased the storeroom immediately south of his present place of business, which is located at 1711 Vine street. Neither departments will be under the same roof. “Coming and going” evidently is the motto of Mr. Link.

The Baldwin Co. will soon come forth with an announcement relative to its phonographic plans before the end of another month, it is believed. Negotiations for the line are now under way. This department will be housed in the building adjoining the Fourth street offices on the east.

Since the embargoes have been lifted on shipments made from the East, the Aeolian Co. has been receiving goods very promptly, and this, together with the shipments made from the Grand Rapids factory, has made it possible for the dealers in the territory to receive very satisfactory service. Manager DeVine, of the local Aeolian store, and Mr. Stephens, of the wholesale Vocalion department, paid a short visit to the Grand Rapids factory last week and were very much gratified to find the production greatly improved and a carload of Vocalions started for Cincinnati.

The splendid output of the new lateral cut records and the demand for same has caused the utilization of the entire fifth floor of Aeolian Hall and the wholesale department is now in excellent shape to take care of both old and new dealers.

Quite a few new dealers have been signed up in the territory lately, and the road men report a very bright outlook for the coming year. There has been quite an enlargement in all orders received from the established dealers.

The Phonograph Co., handling the Edison line, does not expect to occupy its new home on West Fourth street, near Plum street, before

May, for Cincinnati has numerous carpenters who are on a “vacation,” to the annoyance of Manager Oelman.

The Huss Bros. Phonograph & Piano Co. reports a wonderful increase in sales over last year. The deal for another factory to take care of the increased demand for the Re-Call phonograph has been practically completed. The purchase of this plant will increase production one hundred fold, and the company feels that with this increased capacity it will be able to take care of all orders and insure prompt deliveries for the time being at least.

“March Victrola business,” the Rudolph Wurlitzer Co. states, “everything considered, was very good. The increase in the sale of the small Victrola IV was so great that we were entirely sold out of them. We have a number of orders on our back order file awaiting additional shipment of this attractive Victrola from the factory. There was also a very noticeable increase in the sale of the Victrola IX. Portable Victrolas will continue to sell very readily for the next six months, for they will be in great demand by the vacationist and camper. Popular priced records in the ten and twelve-inch double face numbers are still very scarce, and the sales naturally fell off, owing to our inability to get them in sufficient quantities.”

**ARRANGE FOR LARGER QUARTERS**

H. Rau, 110 Monticello avenue, Jersey City, N. J., retailer of Victor products exclusively, has filed plans with the building department whereby he will add another story to the building he now occupies, and will make several other important alterations. Mr. Rau expects to have a Victor Temple of Music which will be one of the most attractive Victor establishments in this section of the country. Additional booths will be installed and in fact every detail of the new building will be in thorough accord with the prestige of the Victor product.



**PORTOPHONE**  
Open

## The Portophone

### A High-Grade Portable or Home PHONOGRAPH

Plays all records. Record container in lid holds twenty-four selections. Built in handsome chemically treated Leatherette case. Unexcelled motor. Fully guaranteed.

*Dealers—Write for Prices*

**The Tri-Sales Company**  
Victoria Building  
St. Louis, Mo.



**PORTOPHONE**  
Closed



# A Guaranteed for Pacific

## The Nucleus of a Great New Pacific Coast Industry



**T**HIS splendid plant of the Pacific Phonograph Manufacturing Company is the first unit of a big Phonograph industry.

Ample capital and experienced management are back of it. The experimental stage is passed; a definitely favorable market is established through dealers who recognize a rare quality instrument in the Stradivara.

The present output will be sold to Pacific Coast dealers on an unusual *guarantee of delivery*, that is worth your immediate investigation.

*The*

# STRAD

*Made in the West at  
— and for the East at*



# Delivery Plan Coast Dealers

**T**HE Pacific Phonograph Manufacturing Co., Pacific Coast makers of the supreme Stradivara, "Known for Tone," announces a unique scheme that assures the dealer west of the Rockies an adequate stock of easy-selling instruments at the time they are wanted. Every instrument you contract for will be delivered.

The STRADIVARA is made in six beautiful models, retailing at \$135 to \$300. The model illustrated is the Mozart—\$250.00 retail. Cabinet of African Mahogany, golden or fumed oak; 49" high, 23" wide, 24" deep.

For details, write or wire

## The Pacific Phonograph Manufacturing Company

*Western Makers of the Stradivara*

PORTLAND

OREGON

### The TONE

is the big talking point of the Stradivara; and it keeps the instrument permanently sold.



**"KNOWN FOR TONE"**

# STRADIVARA

*Portland, Oregon  
Coshocton, Ohio*



Edison Message No. 69

Our selling prices on The New Edison (including War Tax) have increased less than 15%, since 1914. We hope it will not be necessary to make further increases in our prices, but, should we be forced to do so, the prices which we establish will be such as, in our opinion, will be "right" for many years to come.

During the period of inflation, we have foregone large profits, which we might easily have made. We have absorbed more than 50% of the increased cost of manufacture. We believe that this policy is appreciated by the public and that it will be particularly appreciated by our dealers, when deflation sets in.

The Wall Street Journal might very well have had us in mind, when it recently said: "While these corporations are probably not making as much money as others, they are building up good-will, which will undoubtedly stand them in good stead later on."

**THOMAS A. EDISON, Inc.**

ORANGE, N. J.



## EDISON JOBBERS AND DEALERS MEET IN INDIANAPOLIS

Kipp Phonograph Co. Acts as Host to Dealers, Who Were Addressed by Wm. Maxwell and Others—Edison Jobbers Also Hold Successful Convention at Claypool Hotel

INDIANAPOLIS, IND., April 6.—With a dealers' convention held on March 12, followed by the first regional group meeting of the Great Lakes group of Edison jobbers, Indianapolis was a hot spot for Edison activities this month and the Kipp Phonograph Co., as host to its dealers and to the jobbers, saw to it that both conventions were highly successful.

At the annual dealers' convention of the Kipp Phonograph Co., William Maxwell, the chief of

son retail store. A sample of each model in the entire Edison line was on display.

The business sessions were held at the Athenaeum of Indianapolis, where a noon luncheon was served. The convention ended in the evening with a banquet in the Riley room at the Claypool Hotel, where the dealers and their wives, sisters and sweethearts as guests of Walter E. Kipp had a most enjoyable time. Vaudeville actors put on a number of stunts and following the banquet there was dancing until midnight.

The group meeting of Edison jobbers was held at the Claypool Hotel, March 15 and 16. Mr. Kipp acted as chairman of the meeting. An important decision in the policy of the Edison Co. in holding annual dealers' conventions in New York was announced. Hereafter instead of the one big convention in New York, there will be five dealers' conventions held by the company throughout the country. The convention for dealers in the Middle West will be held in Chicago in June, affording the dealers in this

was analyzed and discussed in every way. The outcome of the meeting was that every distributor and salesman left Indianapolis with a more complete and intelligent idea of the Edison plans for this year than they had had before. The presence of Mr. Maxwell at the meeting proved a big inspiration and if there was any doubt as to the length the Edison Co. was prepared to go in backing up its distributors, it disappeared in the wave of enthusiasm that swept the conference.

Those in attendance at the conference included B. W. Smith, L. N. Bloom, M. G. Kreusch, Richard C. Goss and E. S. Hershberger, of the Phonograph Co., of Cleveland; M. E. Mikesell, S. H. Buck and R. B. Alling, of the Phonograph Co., of Detroit; William A. Schmidt and G. A. Sholes, of the Phonograph Co., of Milwaukee; Laurence H. Lucker, H. E. Stinchfield, George H. Compton, A. L. Toepel and Joseph Lowry, of the Laurence H. Lucker Co., of Minneapolis; W. C. Eckhardt, R. Haislet and L. A. Suitfin, of the Phonograph Co., of Chicago; W. E. Kipp, J. Cartmill, H. G. Anderson, L. P. Bock, H. R. Bourne, Frank Carter and E. H. Garrard, of the Kipp Phonograph Co., Indianapolis; George C. Silzer, president of the Edison Jobbers' Association, of Harger &



Kipp Phonograph Co. T. & F. Supervisors

Left to Right: H. G. Anderson, J. F. Garrard, J. Cartmill, W. E. Kipp, H. R. Bourne, E. H. Garrard, L. P. Brock, F. C. Carter.

the Edison phonograph division, was present, and he gave the dealers an idea of what the Edison Co. was doing to put the Edison "over the top" in big style this year.

Andrew Smith, vice-president of the Indiana National Bank, spoke on general business conditions and E. F. Brechbeller, the enthusiastic Edison dealer of Bloomington, Ill., gave a convincing talk on the qualities of the new Edison. Most of the convention was devoted to a general discussion of dealers' problems in the form of questions and answers and all of the 248 dealers in attendance gained a world of valuable information from their exchange of ideas and experiences.

The Kipp Phonograph Co. also had a very novel feature in the form of a complete and perfect retail store set up at the convention. The dealers in this way had the advantage of seeing how an Edison department should really be conducted and how it should appear. Window displays and advertising material were all laid out just as though it were in a high-class Edi-

part of the country an opportunity to attend one of the big conventions.

Minneapolis was selected as the city for the next group meeting of the Great Lakes group of Edison jobbers, which will be held some time in August.

One of the features of the meeting was the fact that each one of the Edison distributors brought with him his sales managers and traveling salesmen. The wonderful new Edison field office which the travelers carry with them



Blish, Des Moines; M. M. Blackman, treasurer of the Edison Jobbers' Association, of the Phonograph Co., of Kansas City, Mo.; P. H. Oelman, A. R. Holbrook and Herman W. Schmid, of the Phonograph Co. of Cincinnati.

### COLLIER BROS. CO. INCORPORATES

Oklahoma Distributor of Gennett Records, Modernola and Independent Talking Machines Expands Business—H. C. Collier Is the President of This Organization

OKLAHOMA CITY, OKLA., April 7.—The firm of Collier Bros. was established here last July by H. C. and R. H. Collier, for the purpose of doing a jobbing business in phonographs, records and accessories. The business has grown very rapidly and now the company has incorporated under the laws of Oklahoma with a capital of \$10,000 and will be known in the future as Collier Brothers Co.

The officers of the new company are as follows: H. C. Collier, president and general manager; Col. W. M. Bisbee, vice-president; C. N. Mathews, secretary; Harry Lacy, treasurer, and the following named men compose the board of directors: H. C. Collier, Otis E. Hilton, C. N. Mathews, Harry Lacy, W. M. Bisbee and J. F. Burns.

This company is the Oklahoma distributor for Gennett records and the Modernola and the Independent line of phonographs. In addition to the lines of talking machines and records, accessories will be handled in a very extensive way.

H. C. Collier, the president and the general manager of this business, is one of the best-known as well as one of the best-posted musical merchandise men of the Southwest, as he has had about thirty-one years' experience in a retail and wholesale way.

Christy J. Smith has assumed the management of the Music Shop in Lockhaven, Pa. F. J. Vierra has resigned his position with this house.

## AUTOMATIC COVER SUPPORT

No. 1287

LATEST IMPROVEMENTS MAKE THIS SUPPORT MORE DESIRABLE THAN EVER

Continuous Hinges  
Automatic Stops  
Needle Rests, Etc.

Finished in

- GOLD
- SILVER
- NICKEL
- COPPER
- BRASS

Write for Catalogue

**WEBER-KNAPP CO.**  
JAMESTOWN, N. Y.

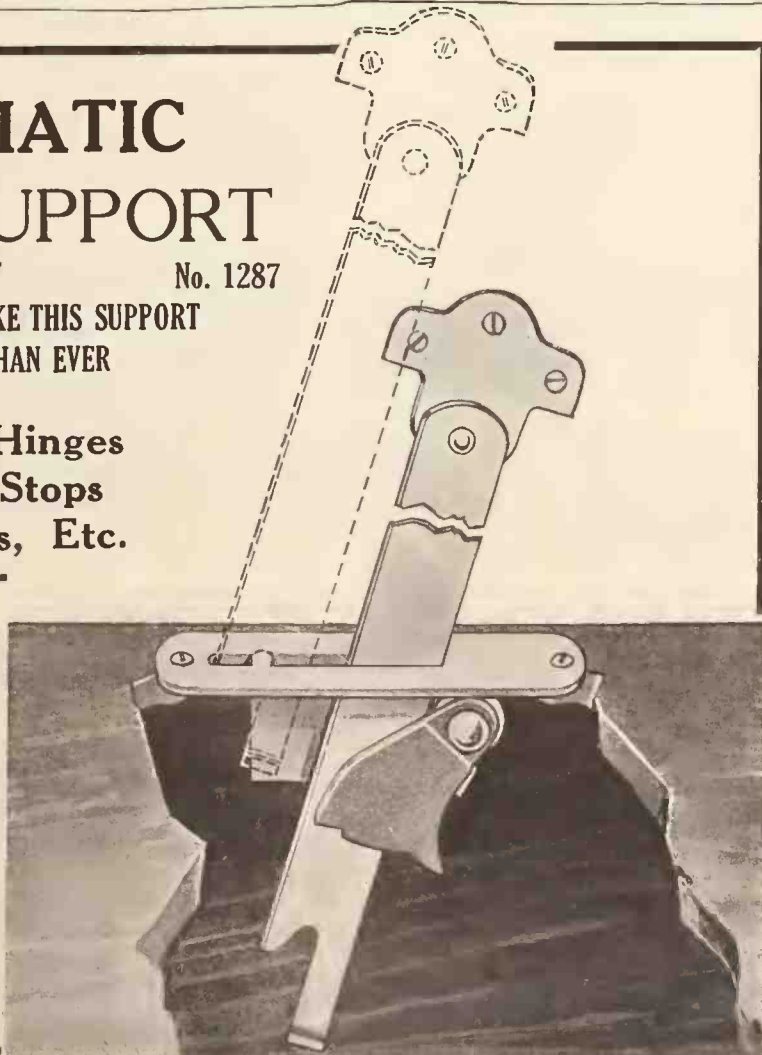



---

# An Open Letter to the Trade!

---

## WEBSTER NOVELTY COMPANY

1314-20 SEDGWICK STREET

DESIGNERS OF:  
HIGH GRADE  
TOOLS, DIES, JIGS  
SPECIAL MACHINERY  
METAL STAMPINGS  
AND MANUFACTURING

PHONE: DIVERSEY 8011

CHICAGO

March 27th, 1920

Mr. Theo. Weiss,  
President, Repeater-Stop Company,  
Chicago, Ill.

Dear Sir:-

In reply to your letter of the 20th inst., requesting information as to the facts involved in the case of the Repeatograph Company against the Webster Novelty Company as featured in their advertisements in the trade journals for March, 1920, it gives me great pleasure to state the following true and absolute facts:-

In the first place, the case referred to was decided, over a year ago in a county court which has no jurisdiction over patent matters. The suit in Judge Foell's court was brought under a contract in which the Webster Novelty Company was interested as the manufacturers of the Repeatograph for the Repeatograph Company. A controversy arose between the Webster Novelty Company and the Repeatograph Company. We had a quantity of the devices on hand for which we received no payment and which the Repeatograph Company refused to take off our hands. So to compensate us for the manufacturing costs of these instruments, we naturally, decided to sell those already made up, but immediately after this decision, came the Repeatograph Company's suit for an injunction.

This suit was brought purely under the contract and for the purpose of restraining us from disposing of the instruments which we had manufactured originally for them, and which of course were made under the Josephson patent.

I am very familiar with all the various repeating devices on the market, yours, as well. I also know that the patents under which your device is manufactured and sold, does not infringe in any way whatever, upon any patents of other repeating or stopping devices so far shown.

I sincerely trust that this information will be entirely satisfactory, thoroughly enlightening to the trade and conclusive proof of our innocence in this case.

Yours very truly,

WEBSTER NOVELTY COMPANY

By

*R. J. Blash*

President



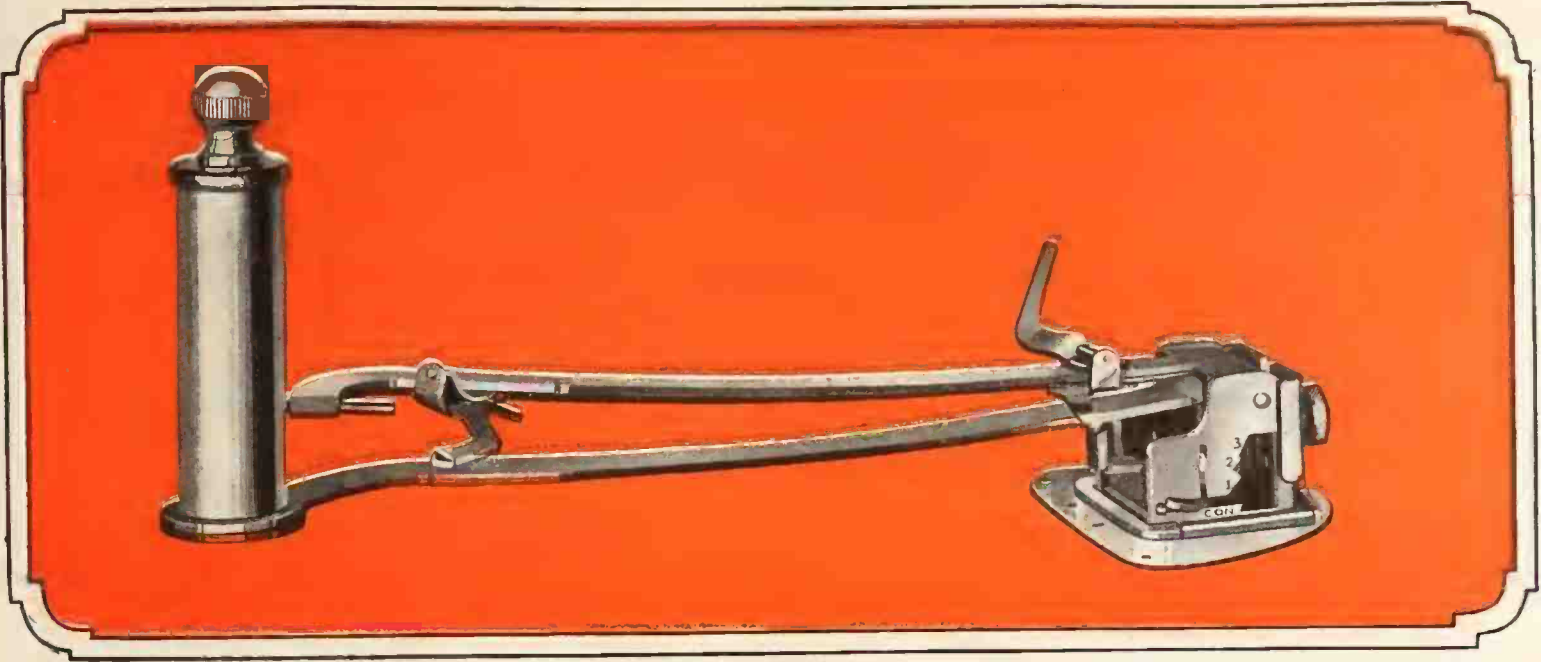

## It Sells Itself!

“The clever salesman” may be able to sell summer underwear to an Eskimo or a Winter Garden Chorus, BUT the Repeater-Stop does its own talking—You won’t have to **sell** the Repeater-Stop—it sells itself—because it fills a **real** want!

One demonstration clinches a dozen sales—one sale clinches a dozen repeat orders—and repeat orders multiply—TRY IT—the proof of the pudding is in the eating.

The combination features embodied in the Repeater-Stop—of a replayer and an automatic **positive** stop—place it in a CLASS BY ITSELF—besides; that it can be set to replay—once—twice—three times, or constantly, puts it a CENTURY ahead of anything—

A common repeater is valueless from the practical standpoint—alone—its utility likewise—

**The Repeater-Stop is not a Tin Toy—**

**It’s built like a battleship—it’s without competition—it can be attached by a child and detached as “quick as a wink!”**

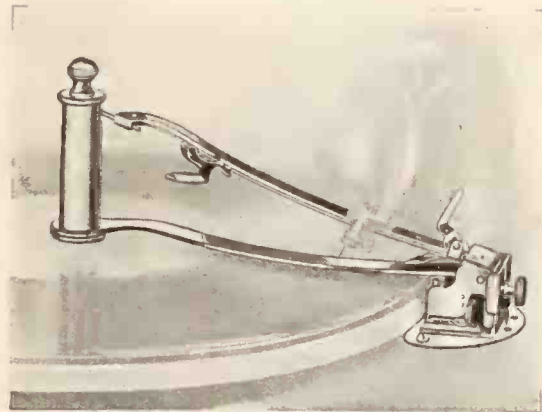

“Beware of imitations, and imitators beware!”

Protected by basic patents, which protect the Jobber, Dealer and Consumer. Under the following patent numbers:

1,060,955	1,275,823	1,317,258
1,062,369	1,317,259	1,317,257

Canadian patent  
171,377

Other United States and foreign patents pending.

**Repeater-Stop**

# THE REPEATER-STOP COMPANY

115 S. DEARBORN STREET  
CHICAGO

I. MONTAGNES & CO.  
Toronto, Canada  
Canadian Distributors



Emerson  
Records

# Northwest Phonograph Jobbers, Inc.

SPOKANE, WASHINGTON

Emerson  
Records

Thoroughly Covering Washington, Northern Oregon, Northern Idaho and  
Western Montana as Factory Distributors for

## Emerson Records, Brooks and Paramount Phonographs

and a complete line of Phonograph Accessories, including  
BRILLIANTONE AND WALL KANE NEEDLES, RECORD ALBUMS, RECORD BRUSHES, ETC.

As a \$100,000 corporation officered by men thoroughly familiar with the musical instrument  
business as a result of many years' experience, we can assure dealers in our territory at all times

**ESPECIALLY DEPENDABLE SERVICE and EXCEPTIONALLY COMPLETE STOCKS**

INQUIRIES SOLICITED FROM DEALERS ONLY

### IMPORTANT PACIFIC COAST DEALS

Wm. A. Condon Returns From Extensive Trip in Which He Closed Arrangements Whereby Many Manufacturers Will Handle the New Tone Arms and Amplifiers

Wm. A. Condon, president of Condon & Co., Inc., New York, returned recently from an extended trip which included a visit to all of the leading trade centers as far West as the Pacific Coast. While on this trip, Mr. Condon closed negotiations with Sherman, Clay & Co., whereby his company will be Eastern representatives for this well-known house.

In a chat with *The World*, Mr. Condon commented optimistically upon the general business situation throughout the country. He stated that the talking machine trade is in excellent shape, and that manufacturers, jobbers and dealers are making plans for a healthy 1920 business that gives every promise of outdistancing any previous year.

One of the features of this trip was the consummation of several important deals whereby well-known manufacturers will use the new tone arms and amplifiers which are manufactured by the Copper Process Co., under its secret process of fabricating copper. Condon & Co. recently secured the sole distributing rights for these products, and Mr. Condon was delighted with the favorable reception accorded these tone arms and amplifiers by the leading members of the trade.

Considerable success has been achieved by the manufacturers of these products in duplicat-

ing the present standard designs of tone arms and amplifiers, and Mr. Condon states that in the very near future new and original designs of tone arms and amplifiers manufactured under this secret process will be ready for the trade.

Uniform needles for which Condon & Co. are sole distributors, are increasing in popularity steadily, and on Mr. Condon's recent Western trip several deals were closed whereby these needles will receive excellent representation.

### THE SONATA IN NEW ENGLAND

Musical Products Co. Will Act as Distributors in New England Territory

BOSTON, MASS., April 6.—A newcomer into the New England territory is the Musical Products Co., which has lately been organized to act as the New England distributors for the Sonata talking machine. For the present temporary headquarters have been established at 134 Summer street. E. B. Shiddell, for many years with the Columbia as branch manager in Dallas, Tex., as representative in Cuba and more recently located in the Cincinnati field, will be the manager of the new concern. A full-page advertisement of the Sonata will be found on another page of this issue and a review of the specifications of this instrument may convince live dealers, for whom Manager Shiddell will from now on be on the lookout, that this is just the talking machine they would like to handle. Manager Shiddell, who has already arrived in town, is busily engaged in assembling a competent staff.

### PLAN FOR ADVERTISING CONVENTION

Tom Griffith of Udell Works One of the Most Active Factors in Preparing for Great Meeting of Advertising Men in Indianapolis

INDIANAPOLIS, IND., April 2.—Indianapolis worked hard to secure the annual convention of the Associated Advertising Clubs of the World for 1920, and is now working hard to make that convention a bright spot in advertising in industrial history. It is hoped to bring to the city between 5,000 and 6,000 people for the convention, and to have a program that will be helpful not only to advertising men, but to business men generally who depend for their success upon the proper sort of advertising. The convention will be held on June 6-10.

One of the hard workers on the convention plans is Tom Griffith, sales manager of the Udell Works, and a member of the National Program Committee and the Convention Board. He declared that any man interested in advertising, selling and distributing pianos, talking machines and accessories of all kinds, could not do better than come to Indianapolis on this occasion.

There has just been issued by the committee an illuminating little booklet containing twelve facts about Indianapolis, one for every hour of the clock, and all facts that reflect great credit upon the progressiveness of the city.

The Acme Phonograph Motors Corp., Manhattan, 6 East Sixteenth street, has been incorporated with \$100,000 capital, by F. H. Hedinger, C. P. Evans and M. Samuels.



Model 137

# Sona-Tone

*A faithful reproduction of all records*

Tone perfection achieved by the "Bell-Hung" amplifying chamber. Ready for immediate delivery. For better music, better entertainment, you can provide no

Wonderfully built. Moderately priced. And yielding a margin of profit beyond the average. finer instrument for your customers than *Sona-Tone*—the proven phonograph. Write for details.

MODEL 137 (as illustrated)—Solid mahogany. Needle cup indicator. No. 16 Meisselbach motor. Universal sound box. Supreme tone arm. List, \$150. Complete specifications on request.

**Sona-Tone Phonograph Division  
of American Business Corporation**

Executive Offices and Demonstration Rooms  
1780 BROADWAY NEW YORK





### PHONOGRAPHS AND RECORDS

Created for the better grade of dealer who desires a phonograph of quality.

The Empire line shows value in every way—designs, workmanship, finish—every detail will stand your examination.



**Model B**  
Mahogany, Oak or Walnut

**The Machine that Plays any Record**

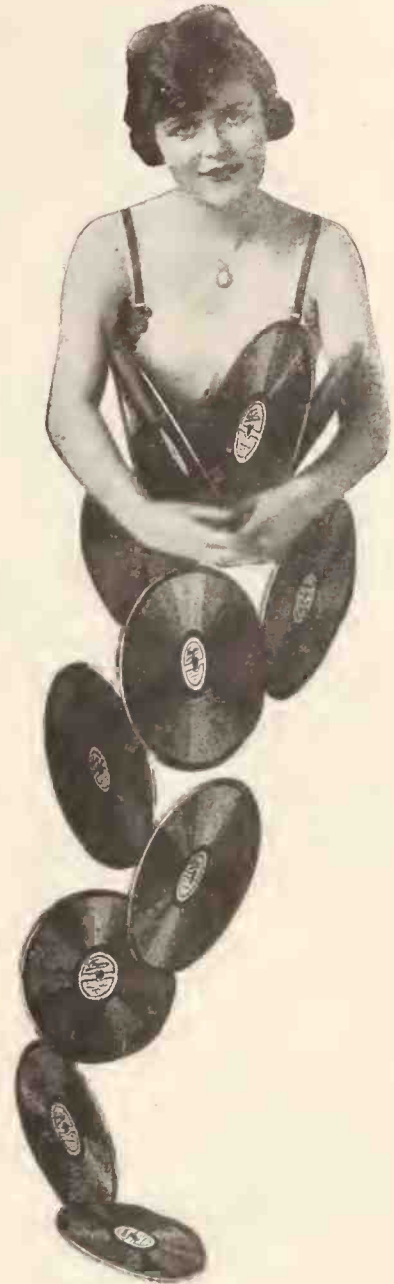

Empire Records Play on all Phonographs Using a Steel Needle.

8 Models—Retail Prices \$40 to \$300

*Write for our Catalog and Agency Proposition*

# EMPIRE TALKING MACHINE CO.

John H. Steinmetz, President  
429 South Wabash Avenue, Chicago, Ill.



THE SATURDAY EVENING POST

April 3, 1920

# SONG "HITS"

By Exclusive Emerson Stars



WE WANT to go on record (and it's true, as sure's you're born!)—the song hits that you so admire are hollered down a horn. A mammoth horn, as you can see, and wondrous patient, too. For sometimes it is hours and hours before a singer's through. But finally the task is done—the song comes flowing out; and every one in chorus yells, "A HIT, WITHOUT A DOUBT!"

No wonder Emerson song hits "go over" BIG. Look at the exclusive Emerson stars that sing 'em —Eddie Cantor, Arthur Fields, the Kaufman Brothers, "Irving and Jack," and the latest addition to the staff, the famous Irish Tenor, Walter Scanlan! Emerson records feature not only the pick of the many good songs going the rounds, but also the artists who know how to make them real hits.

Emerson records cater to the quite human desire for hits that are "hum-able" and "whistle-able." A few of these "rememberable" Emerson hits are listed below.

Ask any Emerson dealer to play them for you. And while you are listening, try to make your feet behave.

- 10145 [You're a Million Miles From Nowhere  
Somebody ..... Walter Scanlan
- 10147 [Peggy ..... Walter Scanlan  
When My Baby Smiles ..... Arthur Fields
- 10130 [Dardanella ..... Irving Kaufman  
I Never Knew ..... Arthur Fields
- 10140 [Venetian Moon ..... Sterling Trio  
If You're Only Fooling 'Round Me ..... Irving & Jack Kaufman
- 10134 [Oh! The Last Rose Of Summer ..... Eddie Cantor  
You Ain't Heard Nothing Yet ..... Eddie Cantor
- 10119 [Come On and Play Wiz Me, My Sweet Babe  
All The Boys Love Mary ..... Eddie Cantor
- 10137 [Sunny Weather Friends ..... Arthur Fields  
Luey ..... Irving & Jack Kaufman
- 10126 [Patches ..... Arthur Fields  
Why Did You Do It To Me, Babe? ..... Jack Kaufman

EMERSON PHONOGRAPH CO., Inc.

Makers of Standard 10-inch Gold Seal Records

Also records in foreign languages

Emerson Records "measure up"—a full 10 inches—and "every inch a hit."



# Emerson Records

CAN'T you imagine the hit this unusual ad will make in two million families, more or less! We're all set for "Sunny Weather, Friends," and we want you with us, if you're not already.

Look for the above good-natured full page Emerson ad in the Saturday Evening Post of April 3rd. To put a smile on your pocket-book, feature the Emerson records featured here. Talk the Emerson Stars talked in this advertisement. Successful dealers know that it pays.

EMERSON PHONOGRAPH COMPANY, Inc.

NEW YORK  
206 FIFTH AVENUE

CHICAGO  
7 EAST JACKSON BLVD.



**The Columbia Novelty Record this month is the Royal Serbian Tambouritza Orchestra's "Fast Polka" and "Grandmother's Waltz." It will bring you in receipts so fast that your grandmother well may waltz. E-4520.**

**Columbia Graphophone Co.  
NEW YORK**



**INDIANAPOLIS TRADE PLANS TO FORM AN ASSOCIATION**

**Many Subjects to Be Considered—Interest Charges to Be Adopted by Leading Dealers After April 1—Recent Managerial Changes—Record Trade Very Active—Newsy Brieflets**

INDIANAPOLIS, IND., April 2.—A movement is now under way to perfect an organization of local talking machine dealers. Carl Anderson, of the Indianapolis Talking Machine Co., said that the purpose of the proposed association would be to give protection to the public against "fly-by-night" talking machines and to benefit the trade by the adoption of uniform terms and interest charges.

Eight of the leading dealers have signified their intention of adopting interest charges in some form after April 1 and the chief question now being considered is whether the dealers should adopt a cash price on which interest is to be charged at 6 per cent, or to make the price include interest, which would be deducted on cash sales. A few of the dealers have been charging interest, but most of them, up to now, have not done so. A meeting is to be called soon to which all legitimate dealers will be invited to discuss the organization and the objects of the proposed association.

The Widener Grafonola Shops, Inc., will start remodeling the local store next week. W. G. Wilson, manager, said that twelve new booths would be installed and the store entirely re-decorated.

Morris Rosner, of the Pearson Piano Co., has been promoted to manager of the talking machine department, succeeding Mrs. J. E. Fish.

George Stewart, of the Stewart Talking Machine Co., on his return from the Victor fac-

tory, said that prospects were good for increased shipments, especially stock records. Miss Caroline Hobson, in charge of the educational department of the Stewart Co., is attending the Red Seal School at the Victor factory. Mr. Stewart was grieved to learn of the death of Ferd Imfeld, for years a Victor dealer at Hamilton, O., on March 19.

Charles B. Lang has been appointed assistant to manager of the Indianapolis branch of the Columbia Co., succeeding T. B. Niles, who was promoted to assistant manager of the Pittsburgh branch of the company.

Ben Brown, manager of the Indianapolis Columbia branch, was highly pleased with the enthusiasm displayed by Columbia dealers at the monthly meeting, held at the Lincoln Hotel March 19.

The new record releases were played for the dealers and heavy orders were taken on "Venetian Moon," the latest Columbia "hit." The chief subject of the meeting was the retail sale of a Grafonola, George I. Schuetz acting in the capacity of salesman and C. P. Herdman, of the Baldwin Piano Co., acting as the retail customer. The Grafonola was sold to the customer. Mr. Schuetz brought out one point worth special consideration in selling a Grafonola to a husband—"It was not necessary to have your wife come down and look at the instrument and if you are satisfied, in your own mind, that this is the music you want, have it

sent to your home as a surprise, as there is nothing that would please your wife or family more than this." This will close a sale in nine cases out of ten. The dealers were entertained by Van and Schenck with a number of their selections; also by Eddie Cantor and John Steel, who were in Indianapolis with the "Follies." Manager Brown says this was probably the most constructive meeting the branch has ever held.

Van and Schenck, exclusive Columbia artists, during their stay in Indianapolis with the "Follies," gave afternoon concerts at the Music Shop of the Baldwin Piano Co. and the Grafonola Shops, and many people were happy to meet them personally.

The Hook Drug Co., of Indianapolis, opened its new Illinois street store, where it will handle Columbia Grafonolas and Columbia records exclusively. Mr. Williams, formerly with Pearson Piano Co., will have charge of this department.

New representatives of Columbia in the Indianapolis territory are: Alvah Green, New Albany, Ind.; F. R. Goppel & Son, English, Ind., and the Hook Drug Co., Indianapolis, Ind.

John C. Robinson, of New York, has joined the sales force of the Indianapolis Talking Machine Co., Victor dealers.

Carl Anderson, president of the Amplifone Co., visited the St. Louis trade last week. Among the latest purchasers of the Amplifone are Lion's Department Store, of Toledo; Byron Mauzy, of San Francisco; Batterman Co., of Brooklyn, and McCreery & Co., of Pittsburgh.

In the Sonora department of Charles Mayer & Co., which handles Emerson records, Eddie Cantor sang a number of his record selections.

**STERLING REPRODUCER**

*Victor and Edison Dealers:*

**Hear the Sterling—  
Examine its  
Construction—  
Note how it plays  
both lateral and  
hill and dale records**

**—and YOU WILL  
WANT TO SELL IT**

*Attachments for either  
Victor or Edison machines*



**Plays all Records**

To adjust for the playing of different records, means just a quick, easy turn of the reproducer. No extra elbows. You ought to see and HEAR the Sterling. You will be surprised at its convenience, its beauty and wonderful improvement of tone.



*Send for circular and prices*

**Krasberg Engineering & Manufacturing Corporation**

536 Lake Shore Drive

Chicago Illinois U.S.A.



# THE DEMAND OF A NATION

## The Player-Tone Phonographs

*"It's Simply Great"*

The superior quality embraced in our line insures unequaled and permanent satisfaction. The beautiful designs, together with the wonderful tone volume, afford you complete selections. The immense output and specializing in the manufacturing of the **PLAYER-TONE** exclusively mean the **Greatest Phonograph Value** for all progressive dealers who are desirous of offering their customers the best that skilled labor and money can produce.

*"When Sold They Stay Sold."*

We have the lowest price, considering beauty, cabinet work and tone quality, after all.

Dealers, write us for our booklet and special discount, on our six models in all finishes.

Desirable territory open for live representatives. Write us today.

## The Player Tone Talking Machine Co.

Executive Office, 967 Liberty Avenue

PITTSBURGH, PA.



Model 316  
Height, 51½"  
Width, 24"  
Depth, 25"



Model 314  
Height, 49½"  
Width, 23"  
Depth, 24"



Model 311  
Height, 46"  
Width, 21"  
Depth, 23½"

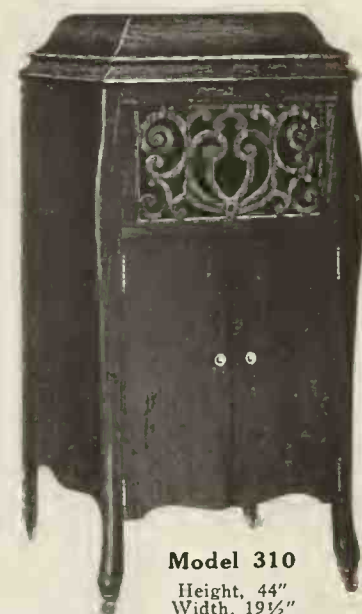

Model 310  
Height, 44"  
Width, 19½"  
Depth, 21"

### THE BRUNSWICK ART CATALOG

Handsome Volume Just Issued Presents Brunswick Phonograph Models DeLuxe in a Most Attractive Way—Regular Models Also Shown

There has just been issued by the Brunswick-Balke-Collender Co., under the title "Music Enthroned," a catalog of surpassing interest and attractiveness devoted to the exposition of the Brunswick phonograph Model DeLuxe, representing authentic reproductions of period styles in cabinet design and finish. The catalog has been produced on a most elaborate basis, rich in color, and presents the period styles in a manner that is distinctly impressive.

Shown as they would appear in the homes of

the elite, are Les Beaux Arts, of the Louis XVI period, Il Lombardi, of the Italian Renaissance, the Oxford, a handsome William and Mary model, and the Gotham, representative of the early American, or Colonial. The machines and their settings are presented in water color effect, the plates occupying four pages, while on the facing pages there are presented details regarding the designs and styles of the several models.

On the last page of the catalog there are shown in half-tone illustrations of the regular styles of Brunswick phonographs, eight of them, with the prices of both period models and regular types shown on an extra slip attached to the back cover.

The catalog as a whole should prove of dis-

tinct value to Brunswick dealers in their work of exploiting and selling the various Brunswick period models, particularly in view of the general favor that such models have found with the public. A prologue tells of the reason for the period models and the manner in which they add to the attractiveness of the home.

### REFLEXO CO. ANNOUNCES REMOVAL

The Reflexo Products Co. announces the removal of its offices in the Marbridge Building to 347 Fifth avenue, New York. These offices are located conveniently for the trade, both locally and out-of-town, and will provide increased facilities for taking care of the company's steadily growing business.



# HAAG RECORD FILES

Give your customers an opportunity to buy a *real* record file. A slight pressure on the key hands you the record from non-binding compartments.

Write for Complete Catalogue

Manufactured Exclusively by  
**HAAG & BISSEX CO.**  
PHILADELPHIA, PA.

Distributed Exclusively by  
**BLAKE & BURKART**  
Herbert E. Blake, Successor  
1100-1102 Walnut Street  
PHILADELPHIA, PA.



# ARROW LATERAL RECORDS

## *Protected by Patents*

*Dealers handling  
Arrow Lateral Records  
are protected by new  
basic patents of the  
phonograph record  
industry.*

We are receiving orders for sample records from all over the civilized world. In order to preclude an unwieldy accounting department to take care of these small shipments, dealers are requested to remit checks covering their first orders.

- |     |   |   |                         |
|-----|---|---|-------------------------|
| 501 | { | LIGHT CAVALRY OVERTURE.....                       | Arrow Military Band     |
|     |   | THE CRUSADER MARCH.....                           | Arrow Military Band     |
| 502 | { | AT THE JAZZ BAND BALL, One-step.....              | Futurist Jazz Band      |
|     |   | BLUIN' THE BLUES, Fox-trot.....                   | Futurist Jazz Band      |
| 503 | { | SLIM TROMBONE, One-step.....                      | Futurist Jazz Band      |
|     |   | MY LOVIN' ESKIMO, Fox-trot.....                   | Futurist Jazz Band      |
| 504 | { | LASSUS TROMBONE, One-step.....                    | Futurist Jazz Band      |
|     |   | BEALE STREET BLUES, Fox-trot.....                 | Futurist Jazz Band      |
| 505 | { | DARDANELLA, Fox-trot.....                         | LaSalle Dance Orchestra |
|     |   | THAT NAUGHTY WALTZ.....                           | LaSalle Dance Orchestra |
| 506 | { | MY WILD IRISH ROSE, Tenor.....                    | Charles Hart            |
|     |   | GOLDEN GATE, Duet.....                            | Burr-Campbell           |
| 507 | { | MOTHER MACHREE, Tenor.....                        | Henry Burr              |
|     |   | CAROLINA SUNSHINE, Baritone.....                  | Elliot Shaw             |
| 508 | { | OH, WHAT A PAL WAS MARY, Tenor.....               | Charles Hart            |
|     |   | I'M LIKE A SHIP WITHOUT A SAIL, Duet.....         | Hart-Shaw               |
| 509 | { | ASLEEP IN THE DEEP, Basso.....                    | W. Glenn                |
|     |   | DAVY JONES' LOCKER, Basso.....                    | W. Glenn                |
| 510 | { | YOU'RE MY GAL, Duet.....                          | Bernard-Hare            |
|     |   | SEE OLD MAN MOON SMILE, Duet.....                 | Bernard-Hare            |
| 511 | { | I DON'T WANT THE DOCTOR, Baritone.....            | J. Kaufman              |
|     |   | CHASIN' THE BLUES, Baritone.....                  | Al Bernard              |
| 512 | { | BEDOVIN LOVE SONG, Basso.....                     | W. Glenn                |
|     |   | ROCKED IN THE CRADLE OF THE DEEP, Basso.....      | W. Glenn                |
| 513 | { | IF I EVER GET YOU (Novelty Whistling Chorus)..... | F. Bowers               |
|     |   | NOW I KNOW, Baritone.....                         | Elliot Shaw             |
| 514 | { | I MIGHT BE YOUR ONCE IN A WHILE, Contralto.....   | Louise Terrell          |
|     |   | WHEN THE HARVEST MOON IS SHINING, Duet.....       | Hart-Shaw               |
| 515 | { | BAKE DAT CHICKEN PIE, Duet.....                   | Collins-Harlan          |
|     |   | THE PREACHER AND THE BEAR, Descriptive.....       | A. Collins              |
| 516 | { | HAWAIIAN MOONLIGHT, Duet.....                     | Terrell-Shaw            |
|     |   | I NEVER KNEW, Tenor.....                          | Henry Burr              |
| 517 | { | PEGGY, Fox-trot.....                              | LaSalle Dance Orchestra |
|     |   | YOU KNOW, One-step.....                           | LaSalle Dance Orchestra |
| 518 | { | OCCIDENTAL MARCH.....                             | Arrow Military Band     |
|     |   | WASHINGTON POST MARCH.....                        | Arrow Military Band     |

LABORATORY  
16-18 W. 39TH ST.  
NEW YORK

EXECUTIVE OFFICES  
1836 EUCLID AVE.  
CLEVELAND, OHIO

May we send our Dealers' Proposition?

**ARROW PHONOGRAPH CORPORATION**

*Arrow Records are made with a Lateral Groove by an entirely new method, carrying the minutest sound values to a degree of perfection hitherto unattained by any of the older processes.*



## SILVERSTONE MUSIC CO. ENTERTAINS EDISON DEALERS

Over 100 Dealers and Their Wives Attend Luncheon and Banquet as Well as Important Business Meeting—Interesting Talks by Messrs. Maxwell, Col. Hollenberg and Others

St. Louis, Mo., April 3.—An Edison dealers' convention of unusual note and great enthusiasm took place in this city last month at the Statler Hotel when the Silverstone Music Co. entertained about one hundred Edison dealers and their wives with a luncheon and banquet. The dealers met at the establishment of the Silverstone Music Co., where they registered, and souvenir badges were distributed. These badges were made from the medallion used on the official laboratory model phonographs.

William Maxwell, the popular vice-president of Thomas A. Edison, Inc., addressed the dealers at the morning and afternoon sessions, outlin-

Gordon, of Blane's Drug Store, Cadiz, Ky.; J. Fikuart, of J. Fikuart, Frankford, Mo.; A. B. Pyle, of A. B. Pyle, Forrest City, Ark.; A. W. Montgomery, of A. W. Montgomery, Louisville, Ill.; C. W. Slaybaugh, C. W. Slaybaugh, Jr., G. S. Kerwin, of C. W. Slaybaugh, Taylorville, Ill.; E. N. Webb, C. S. Glover, of Schubert Merc. Co., Russellville, Mo.; W. J. Tendick, R. T. Tendick, of Tendick Co., Greenfield, Ill.; J. D. Pope, C. C. Allison, of J. D. Pope, Searcy, Ark.; J. Magee, of J. Magee & Son, Palatka, Ark.; L. N. Rost, W. W. Gardner, R. L. Rost, of L. N. Rost & Son, Macomb, Ill.; J. W. Milligan, of Milligan & Fly, Carbondale, Ill.; W. N.

Jr., of J. W. McCombs, Jr., Jackson, Mo.; B. H. Pitt, of O. C. Wells, Murray, Ky.; H. A. Tunehorst, E. J. Tunehorst, of H. A. Tunehorst, Jerseyville, Ill.; F. H. Feraud, of F. H. Feraud, Granite City, Ill.; Miss M. Ellis, of Phonograph Co. of Memphis, Memphis, Tenn.; Col. F. B. T. Hollenberg, of Hollenberg Music Co., Little Rock, Ark.; H. H. Bright, of Cochannour & Bryant, Fairfield, Ill.; L. L. Leffler, of Lefflers', Hayti, Mo.; O. J. Falk, of O. J. Falk, Bowling Green, Mo.; Karl Miller, of Hainsfurher Bros., Winchester, Ill.; J. W. Waddell, of J. W. Waddell, Pana, Ill.; Knox W. Wyse, of Halls Hdwe. Co., Halls, Tenn.; C. R. McDonald, of C. R. McDonald, Elsberry, Mo.; W. E. Krug, of Krug Jewelry Co., Staunton, Ill.; Manuel Harbaum, of W. W. Harbaum, Wellsville, Mo.; E. L. Jacoby, Miss F. Smith, C. J. Jacoby, Jr., J. Berner, of C. J. Jacoby & Co., Alton, Ill.; J. M. Hedges, of Parks Music House Co., Louisiana, Mo.; J. W. Scott, C. Kuhn, of Thomas A. Edison, Inc., Orange, N. J.; Z. B. Reid, Lee Reid, of Z. B. Reid, Newport, Ark.; F. Sigman, of Flat River Hdwe. Co., Flat River, Mo.; M. Lowenstein, of Lowenstein & Son, Whitehall, Ill.; E. M. Reynolds, of E. M. Reynolds, Canton, Ill.; O. F. Fischer, of Fischer Bros., Beardstown, Ill.; Chas. Dusenberg, J. Barthel, of Concordia Music Co., St. Louis, Mo.; R. N. Monaghan, of R. N. Monaghan, Gillespie, Ill.; C. O. Gross, of J. Bressmer Co., Springfield, Ill.; J. M. Berger, Miss J. Brejot, of Johnson Berger Co., Jonesboro, Ark.; I. E. Hobson, of I. E. Hobson, Martin, Tenn.; F. A. Kuhlman, of Concordia Music Co., St. Louis, Mo.; Thos. McHarg, Miss Parker, of Parker Furniture Co., Columbia, Mo.; L. C. Schooler, of L. C. Schooler, Centralia, Mo.



Banquet of Edison Dealers and Their Women Folks Who Were Hosts of Silverstone Music Co. ing the promotion plans for 1920. His address was well received and the dealers were enthusiastic over the plans. A turntable demonstration was made for the benefit of the dealers present. Mr. Maxwell was accompanied by Mrs. Maxwell. A. F. O'Dell of Quincy, Ill., delivered a very interesting talk on "How I Sold \$12,000 Worth of Edisons in July," which was listened to with rapt attention. Chas. Dietzel, of Union City, Tenn., gave a talk on "Truck Canvassing."

The banquet was a most elaborate affair, and lasted the entire evening, with Mark Silverstone acting as toastmaster. Frequent reference was made in toasts and speeches to Thomas A. Edison. Talks were made by Wm. Maxwell and Col. Hollenberg, of Little Rock, Ark. A very elaborate entertainment was furnished during the banquet, with special features appropriate to the Edison. A parody, "Good Morning, Mr. Chip, Chip," was sung by an octet from Quincy, Ill., which was enthusiastically received. Z. B. Reid of Newport, Ark., recited an original and unique poem, entitled, "Why I Sell the Edison."

J. W. Scott, Amberola supervisor, and C. W. Kuhn, supervisor of discs, were present. Souvenirs were given to everybody.

The dealers present from St. Louis, Southern Illinois, Missouri, Arkansas and Tennessee were:

W. L. McFadden, E. H. Cook, of D. E. Guthrie, Raymond, Ill.; C. Durham, of Southern Illinois Music Co., DuQuoin, Ill.; R. A. Emmons, of Emmons & Hays, Marissa, Ill.; J. H. Wolff, of Hochtchen & Wolff, Astoria, Ill.; R. T. Cunningham, of Cunningham's Book Store, Flora, Ill.; C. L. Casey, of Iberia Merc. Co., Iberia, Mo.; Geo. N. Nichols, of Geo. N. Nichols, Plymouth, Ill.; John H. Carner, of O. J. Davis, McLeansboro, Ill.; C. A. Heuter, of C. A. Heuter, Greenville, Ill.; D. E. Guthrie, of D. E. Guthrie, Raymond, Ill.; R. P. Ganno, of Geo. W. Brown, Jr., Hillsboro, Ill.; R. S. Moore, F. W. Pilcher, of Pilcher Jewelry Co., Mexico, Mo.; J. D. Kuykendall, of Gibson Piano Co., Paducah, Ky.; Chas. Dietzel, of Chas. Dietzel, Union City, Tenn.; P. M. Hornbeak, of Hornbeak Furn. Co., Fulton, Ky.; M. J. Blythe, of Campbell Coates Co., Hopkinsville, Ky.; J. C.

Terry, of J. M. Terry, Elbrado, Ark.; G. W. Baker, of G. W. Baker, Loami, Ill.; R. G. Brown, of Milligan & Ely, Carbondale, Ill.; P. J. Schell, of Schell Music Co., Jefferson City, Mo.; Mrs. G. DuVall, of DuVall & Hurst, St. Charles, Mo.; Wm. Hobson, of Wm. Hobson, Greenfield, Ill.; A. F. O'Dell, C. P. Salyer, A. S. Vaughn, C. M. Stewart, H. G. Anderson, C. H. McNeall, A. C. O'Dell, Quincy, Ill.; W. G. Vincent, Mt. Sterling, L. M. Spicer, of A. F. O'Dell, Hannibal, Mo.; J. J. Gaffner, of J. J. Gaffner, St. Jacob, Ill.; Wm. Zeitler, C. Leyerle, of Zeitler Jewelry Co., St. Louis, Mo.; Jos. Madeiary, of Grand Leader, St. Louis, Mo.; Miss Mary Spicer, Mrs. Pruett, of J. R. Spicer, Paris, Tenn.; J. W. McCombs,

## COATESVILLE PATHE DEALER MOVES

Miller Piano Co., Inc., Installed in New Home in Heart of Business Section

COATESVILLE, PA., April 6.—The Miller Piano Co., Inc., which handles the Pathé line of machines and records, moved into its new quarters at 159 Lincoln Highway, one of the main business thoroughfares of the city, on April 1. The business was started five years ago by Harry E. Miller and a year ago a half interest was purchased by O. E. Klinger, formerly sales manager of Kohler & Chase in New York. The business has grown rapidly and a move into larger quarters was deemed necessary. New booths for the demonstration of Pathé records have been installed and the entire interior of the store remodeled attractively.

# VARNISH DRYROOMS

WE GUARANTEE EVERY INSTALLATION TO PRODUCE  
A BETTER QUALITY FINISH  
QUICKER RESULTS

SAVING IN WORKING CAPITAL  
SAVING IN FLOOR SPACE

These are a few advantages derived from equipment manufactured and designed by

## DRYING SYSTEMS, Inc.

322 No. Michigan Ave.

Chicago, Illinois

Address after May 1st, 11-17 So. Desplains St.

Users of our system are licensed under and protected by the GROSVENOR process patent—number 1,186,477



MOELLER  
WATERS  
INC

The OPPORTUNITY to obtain the dealer franchise on a distinctive Phonograph should not be neglected. BEACON furnishes this OPPORTUNITY now; but available territories are rapidly decreasing in number.

BEACON dealers may differ on what they like best in a BEACON—the tone, the Design, or its comparative value—but all agree that above everything a BEACON is distinctive.

To the merchant who is ever alert for the new—the better Phonograph to merchandise—The BEACON is certain to make an appeal.

There is still time, however, to investigate and decide; but delays are inadvisable, to say the least.

Opportunity only asks that you write NOW; Your inquiry will be promptly answered.

MOELLER-WATERS

INC.

*Western Representatives*

Lyon and Healy Building, CHICAGO



R. Fayerweather  
Babcock



## MILWAUKEEANS REPORT LARGER SHIPMENTS

Acute Shortage of Machines Coming to an End—Publicity in Vogue—Badger Enlargement—Yahr & Lange Advertising—New Victor Shop—Interesting Review of Conditions

MILWAUKEE, Wis., April 9.—That the long period of acute shortage of talking machines and phonographs is coming to an end is indicated by the report of jobbers as well as dealers that instruments are now coming through in much better quantity than for nearly three years and that the prospects appear to be favorable to a continuance of the increase in supply. Dealer advertisements published in Milwaukee and vicinity in the last ten days or two weeks suggest that they are now better able to fill demands than for a long time past, and in position to make deliveries with a fair degree of promptness, due to the improved condition of floor stocks.

The publicity of other jobbers and dealers likewise is significant of the coming of the day when merchandise is being supplied in greater measure in proportion to requirements. Doubtless it will be a long time before any dealer has so many instruments on hand that he will wonder what he is going to do with them all. Nevertheless it is realized that the improvement already noted means that real selling must be expected after the long season of "order-taking."

The wide publicity which retailers are giving the fact that their supplies of merchandise are increasing results to some extent from the fact that people have been pretty well "fed up" on talk of acute shortage. To offset the possible disinclination of people to buy because they feel they will not be able to get what they want, dealers are taking steps to acquaint prospective customers with the fact that stocks are now complete and selection is a relatively easy matter, with prompt delivery to the home possible.

The thought arising in this connection that the trade is facing the possibility of oversupply if improvement of recent weeks becomes greater and greater is discounted by the knowledge that the manufacturers are operating under unusually severe difficulties and handicaps and will not be able for a long time to ship all of the goods the jobbers or dealers requisition them for. The shortage of hardwood lumber, the continued shortage of competent and permanent labor, and the lack of adequate supplies of metal products which form an important part of talking machines, all combine to make the lot of the maker a hard one. Not only is the kind of lumber suitable for panels and cabinets at the highest price in history, and several times the price two and three years ago, but the sawmills are far behind on orders and in many instances have been declining to accept more business. Since Northern Wisconsin and Upper Michigan are the greatest producers of best grade hardwoods in America, members of the trade in Milwaukee and vicinity are close to the situation in this respect and know whereof they speak.

In the meantime, to sustain the demand for instruments as well as records, so an increasing supply will be readily absorbed, the dealers here are going to unusual lengths in promoting the advancement of music. The chief agency through which this is being accomplished is the Milwaukee Association of Music Industries. It is constantly doing notable things to keep the public interested in music and then converting the desire into purchases of instruments and supplies. The co-operation which the dealers' association is giving Community Service is especially of interest at this time.

The Badger Talking Machine Co., Victor distributor, has recently enlarged its office and traveling staff to handle a constantly growing volume of business through a broadening dealer organization. The Badger company prides itself upon its service to the retailer and makes it a point to select only such dealers as will make service the transcendent thought. Conse-

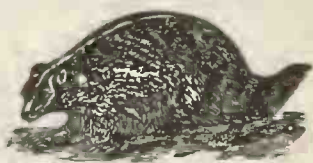

## PERSONAL SERVICE

The members of our Company are always available and will gladly see you personally or write you at any time we can possibly serve you.

Why not communicate at once with us?

EXCLUSIVELY WHOLESAL

**BADGER TALKING-MACHINE CO.** 135 Second Street  
MILWAUKEE, WIS.  
VICTOR DISTRIBUTORS

quently, out of a large number of candidates for franchises, relatively few are finally selected. These are furnishing more than enough business to keep the Badger organization fully occupied at all times.

The Phonograph Co., Edison jobber, is establishing new high water marks for business volume this year and on the basis of the first three months' trade expects to put the previous record, made in 1919, far in the shade.

Probably the most elaborate and comprehensive publicity campaign that has ever been conducted in Wisconsin and Upper Michigan by any phonograph jobber is that which the Yahr & Lange Drug Co. has undertaken in behalf of the Sonora. The famous "Clear as a Bell" trademark is flashing from hundreds of points of vantage throughout the territory and the city and county of Milwaukee are being particularly well placarded with huge signs of artistic composition and attractive design, which are focusing public attention upon the Sonora.

Manager Thomas I. Kidd, of the local branch of the Brunswick-Balke-Collender Co., is elated over the condition of wholesale trade, and the many representative retail stores in Milwaukee and throughout the territory which represent the Brunswick likewise express much gratification over the reception which the line is getting everywhere.

Decided interest in the Columbia line already has been created by the special campaign which

was launched in this territory on Thursday evening, April 1, with a big Columbia convention at the Hotel Wisconsin, Milwaukee. Although the Columbia has always had vigorous representation here, the new effort is of such proportions that it seems bound to have a marked effect in stimulating business in the Grafonola as well as extending the wide influence already held by the Columbia record.

The Playonola Talking Machine Co., one of the more recent entrants of the manufacturing field, on April 1 opened a retail store in the heart of the city on the ground floor of the Free Press Building at 98 Wisconsin street. Jack Hyland is in charge.

A new Victor shop will be opened here about June 1, when Richard H. Zinke, who started the present Badger Victrola Shop on its way six years ago, will establish a store at 410-412 East Water street. For two years Mr. Zinke has been manager of the Record-Lite Co. and Record Needle & Mfg. Co., later combined as the Interstate Music Corp. He has resigned to carry out a new idea of featuring record and player roll merchandising "over the counter," at the same time handling the Victor instrument exclusively and general musical merchandise.

The Kesselman-O'Driscoll Co., Victor and Edison dealer, has inaugurated a series of monthly social gatherings for its employes. The

(Continued on page 121)

# Delpheon

*the*  
**Incomparable**

### A Valuable Franchise

One Delpheon Dealer in a place—room for only limited number of new dealers.

An unusual opportunity for securing exclusive rights for your locality.

A contract with us means your orders filled.

*A tone that is ineffably  
exquisite—not phonographic*

STEADILY INCREASING PRODUCTION ASSURES DELIVERIES

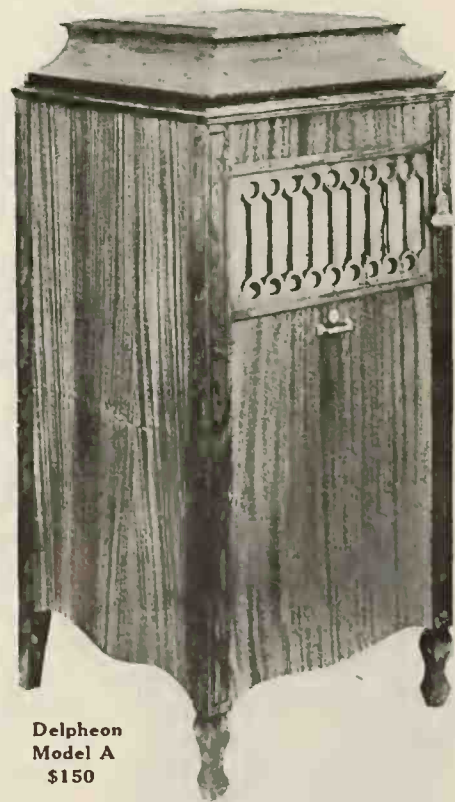

Delpheon  
Model A  
\$150

## THE DELPHEON COMPANY

Bay City, Michigan

New York Office, 25 Church Street  
Rosen Phono. Sales Co., 27-28 Court Street, Boston, Mass.  
Delpheon Shop, Peachtree Arcade, Atlanta, Ga.  
Walter Verhalen Co., 703 Busch Building, Dallas, Texas  
Verbeck Musical Sales Co., Buffalo, N. Y.



# A RECORD-FLASHER

REG U S PAT OFF

Should Be On Every  
**TALKING MACHINE**

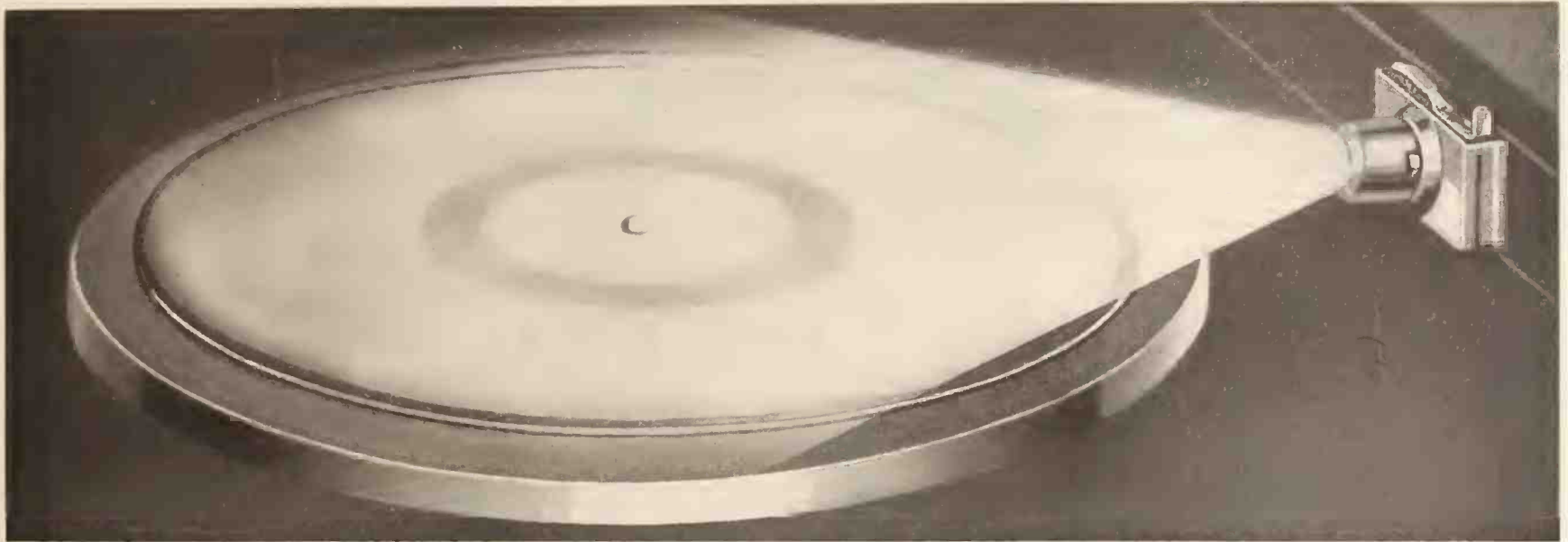

## AT LAST

A new light that will apply to every make of talking machine in the world. It is reliable, easily applied, and will give perfect satisfaction. Beautifully finished in nickel and gold. Both lights and batteries are fully guaranteed. Low in price, within reach of every talking machine owner or buyer. Big discounts to dealers. Write your jobber or direct to us for descriptive circulars outlining our selling and advertising campaign.

### RETAIL PRICES

Nickel Finish . . . . \$2.25

Gold Finish . . . . \$3.00

Battery . . . . 75 cents

ENTIRELY NEW PROPOSITION



Special RECORD-FLASHER Battery



Angular

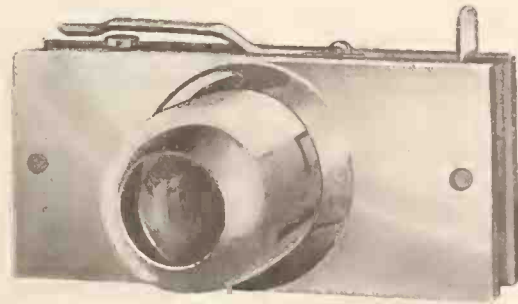

Vertical  
(Exact Size)



Horizontal

Each package neatly packed with three reflectors as illustrated above

# STANDARD ACCESSORY CORPORATION

355-357 East Water Street

MANUFACTURERS  
and  
PATENTEES

Milwaukee Wisconsin U.S.A.





Style 430  
Price \$165

## THE AEOLIAN-VOCALION

*The Phonograph that has made the Talking Machine a Real Musical Instrument. Manufactured by the Aeolian Company—Largest Manufacturers of Musical Instruments in the World*

### DEALERS EVERYWHERE ARE

successfully handling the Aeolian-Vocalion and obtaining the cream of the Talking Machine Business.

The reputation and prestige of the Aeolian Company, which has spent years building quality merchandise, is reflected in the Aeolian-Vocalion and the New Vocalion Lateral Cut Records.

*We invite correspondence from Dealers*

Ask for the Catalogue of Hits in the New Type Aeolian-Vocalion Lateral Cut Records—playable on all phonographs.

### VOCALION PRICES

*Conventional Models from \$60*

*With Graduola from: \$165.*

*Period Styles from \$280.*

*Handsome catalogue of VOCALIONS and RECORDS sent upon request*

### SOUTHERN DISTRIBUTORS

O. J. De Moll

O. J. De MOLL & COMPANY  
WASHINGTON, D. C.

Emmons S. Smith

*Aeolian-Vocalions*

*Vocalion Records*

*MELODEE Player-Piano Rolls*



**LARGER SHIPMENTS FOR MILWAUKEE**  
(Continued from page 118)

first was in the nature of a "hard times" party that brought out some real masquerade costumes. The gatherings are held at the store.

Miss Helen Gunnis, manager of the talking machine department of the C. W. Fischer Furniture Co., was soloist with the Milwaukee Elks' Band at its first public concert at the Pabst Theatre recently. This is the band organized by Richard H. Zinke, who is its conductor, and who has developed it from a sextette to a band of fifty-six pieces, making it the largest all-Elk military musical organization in the country.

Articles of incorporation were filed recently in behalf of the Phonograph Accessories Co. of Milwaukee. The capital stock is \$50,000 and the incorporators are Adolph F. Krueger, William Blatz and H. H. Karrow, attorney.

The Market Square Music Shop at Kenosha, Wis., has opened a branch on the west side at 204 Newell street, in charge of A. L. Crosby. It features the Victor line.

The Smith Piano Co. will move May 1 to its new home at 274 West Water street. Special attention is being given the Columbia department, which is planned by Secretary and Manager F. D. D. Holmes to be the largest in the city, with a battery of eighteen booths.

Gimbel Bros., formerly exclusive Victor dealers and since February 1 handling also the Brunswick, announced March 25 that the Pathé has been added as a regular line.

The Multitone Mfg. Co., Eau Claire, Wis., maker of the Multitone, recently increased its capitalization from \$100,000 to \$160,000 to accommodate increased business.

The Forbes-Meagher Music Co., 27 West Main street, Madison, Wis., has purchased the building which it has occupied for many years at a price of \$85,000. It will remodel the upper floors, using part of the space for additional talking machine booths, and the remainder for a small auditorium and several studios which will be leased to musicians and teachers. This will make the building the music community center of the State capital.

Charles J. Orth, wholesale distributor for Wisconsin and Upper Michigan, and retailer in Milwaukee of the Puritan, on March 31 published in large space the news of the arrival of a giant shipment, which statement he supported with a reproduction of a snapshot showing several motor trucks lined up before his doors, unloading Puritans by the dozen.

**INAUGURATE A NEW SERVICE**

**Collings & Co. Arrange to Supply Victor Dealers With New Sign Service**

Collings & Co., the well-known Victor distributors of Newark, N. J., have just created a sign service department which will issue monthly a service consisting of six signs, three of them twelve by fifteen inches and three fourteen by twenty-one inches. The first month's service featured "Irene," sung by Edith Day, star of the musical comedy of the same name, an April Victor release. This met with the immediate indorsement of those in the trade who had the opportunity of receiving this most attractive publicity. In future the service can be subscribed for at a very nominal price, considering the highly artistic manner in which it is produced. It is entirely individual in character, and is purposely made to advertise Victor products on a high-class plane.

L. W. Collings, general manager of Collings & Co., recently stated that from the results obtained from the initial announcement there can be no doubt that the trade is more than eager for this specially prepared publicity material.

**SECRETARY OF GOGGAN & BROS. DIES**

**Charles C. La Saliniere, for Many Years With Thos. Goggan & Bros., Passes Away**

HOUSTON, TEX., March 30—Charles C. La Saliniere, aged sixty years, for thirty-six years with the firm of Thos. Goggan & Bros., prominent music dealers, and for the past few years secretary of that company, died Thursday morning at St. Joseph's infirmary. He had been a resident of Texas for forty-five years and had lived in Houston since May, 1917. He is survived in Houston by a son, Kenneth La Saliniere, and several distant relatives.

**BRILLIANTONE CO.'S NEW HOME**

The Brilliantone Steel Needle Co. has moved its headquarters to 347 Fifth Avenue, New York. These offices are but one block distant from the former quarters and are in the midst of the new talking machine district. The location of these offices will prove very convenient to the out-of-town trade, as they are but a short distance from both the Pennsylvania Station and the Grand Central Terminal, which is now the business center of New York.



*Increase Your Record Sales*

Appearance and service are two highly important factors which enter into the success of a music dealer's store.

Unsightly, inefficient built-in shelving is not only repulsive, but invites a disorderly arrangement of your record stock and you cannot give service.



The Reed Record Rack is beautifully constructed, having five compartments of a total holding capacity of 1,250 records. Each of these five compartments has ten divisions of a holding capacity of twenty-five records each.

The side panels and top rail are grooved for the purpose of inserting in these grooves either a celluloid or white cardboard strip, which strips are to be used to show the numbers of the records contained in each division.

Cabinet is so made that additional racks can be set alongside each other, and when so placed in the store a battery of these racks has the appearance of a single unit.

The division slides are removable. This Rack can also be used for player rolls, having a holding capacity for 500 rolls.

**THE REED COMPANY INC.**

5748 Ellsworth Avenue, Pittsburgh, Pa.

**A R E Y O U**

catering only to the **high price** trade and neglecting the **popular price** customer?

For every high priced phonograph sold there is a demand for one hundred cheaper priced machines. The "RECALL" is an ideal proposition for this purpose.

It compares favorably in finish, workmanship and equipment with higher priced phonographs and sells at a price satisfactory to the majority of buyers.

Investigate our proposition; send for sample.

**The Huss Bros. Phonograph & Piano Co.**

6-8-10 W. Canal Blvd., Cincinnati, O.



Height 45" Width 18 1/2" Depth 19"

Sample \$48.50



# Universal Displayors—Talking Machine and Music Trade



No. 516. Triangular Revolving Counter Music Rack. Height, 41 inches, base 15½ inches. Consists of 15 pockets, 5 on each side, with 3 signs on top, 2 popular and 1 classical. Will hold 225 sheets of music, 15 in each pocket. Electrically welded and finished in double baked ebony enamel. Shipped knocked down. Weight, crated, 30 lbs.



No. 563-No. 563A. Universal Stock Record Rack. Something new that will fill a long-felt want. Display your stock records along your wall so that each record is visible at a glance, quickly disposing of all slow-moving records or featuring to-day's best selling records. Constructed of 7 channel steel pockets 1¾ inches deep. Electrically welded together and finished in double baked ebony enamel. Each pocket will accommodate 12 records or 84 in all. Titles all visible with sign on top. Simply fasten a shelf on bottom, place rack on top and fasten with two screws. Height, 58 inches.

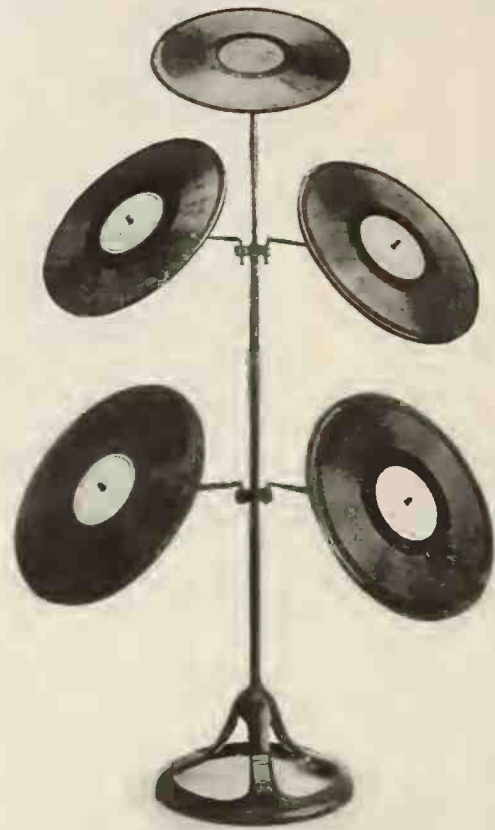

No. 501. Universal Record Displayor, for your window. Holds two 12-inch records and three 10-inch. Constructed of Bessemer steel wire, cast-iron base and sheet steel discs, preventing record from warping. Entire Displayor finished in double baked ebony enamel. Weight crated, 18 lbs. each. Height, 40 inches. Span of base, 10 inches, adjustable, and records can be raised or lowered.

*Effective Salesmen  
Working Without  
Any Expense*

*We Manufacture  
Over Thirty-five  
Different Models*

*Ask for Catalogue—Order Through Your Distributer*

**BALTIMORE, MO.**  
Cohen & Hughes  
E. F. Droop & Sons  
Eastern Music Shop

**BIRMINGHAM, ALA.**  
Birmingham Talking Machine Company  
The Emerald Company.

**BOSTON, MASS.**  
Brown, McManus Company  
Eastern Talking Machine Company  
Kraft, Bates & Spencer, Inc.  
Oliver Ditson Company  
Henderson, F. C.  
Phonograph Supply Company  
Steinert & Sons Company, M.

**BROOKLYN, N. Y.**  
American Talking Machine Co.  
Metropolitan Music Roll Corp.

**BUFFALO, N. Y.**  
Andrews, W. D. & C. N.  
Buffalo Talking Machine Company  
Buffalo Wholesale Hdwe. Co.

**BURLINGTON, VT.**  
American Phonograph Company

**CAMDEN, N. J.**  
Victor Talking Machine Company  
**CEGAR RAPIOS, IOWA.**  
The Churchill Drug Co.

**CELINA, OHIO.**  
Harponols Company.

**CHICAGO, ILL.**  
Butler Bros.  
Chicago Talking Machine Company  
Cole & Dunne Music Co.  
Cummings, Forster Co.  
Empire Talking Machine Company  
Fuller Morrison Co.  
Noble Supply Co.  
Rudolph Wurlitzer Company

**CINCINNATI, OHIO.**  
Phonograph Company  
Rudolph Wurlitzer Company

**CLEVELAND, OHIO**  
Cleveland Talking Machine Company  
The Fischer Company.

**COLUMBUS, OHIO.**  
Perry B. Whitst Company.

**DALLAS, TEXAS.**  
Harbour, Longmire Company  
Sanger Bros.  
Sonora Distributing Company.

**DETROIT, MICH.**  
Wallace Brown

**ELMIRA, N. Y.**  
Elmira Arms Company

**EL PASO, TEX.**  
W. G. Walz Co.

**HOUSTON, TEXAS.**  
Southern Drug Company.  
The Talking Machine Company of Texas

**INDIANAPOLIS, INO.**  
The Talking Machine Company

**JACKSONVILLE, FLA.**  
Florida Talking Machine Co.

**KANSAS CITY, MO.**  
Jenkins Sons' Music Co., J. W.  
Richards & Conover Hdwe. Co.  
Schmelzer Arms Company  
The Phonograph Company  
Wm. Volkor Co.

**LANSING, MICH.**  
Lansing Phonograph Co.

**LINCOLN, NEB.**  
Ross P. Curtice Co.

**MILWAUKEE, WIS.**  
Badger Talking Machine Company  
E. H. Godfrey & Sons Co.  
Hoeffler Phonograph Mfg. Co.  
Yahr & Lange Drug Company

**MINNEAPOLIS, MINN.**  
Beckwith, O'Neill Company  
Minneapolis Drug Co.  
Stone Piano Co.

**NEWARK, N. J.**  
Collings & Price Company

**NEW HAVEN, CONN.**  
Horton, Gallo Creamer Company  
Plaza Music Company

**NEW ORLEANS, LA.**  
Werlein, Ltd., Phillip  
Diamond Phonograph Company

**NEW YORK CITY, N. Y.**  
Brown, McManus Company  
Cabinet & Accessories Company  
Century Music Publishing Company  
Crown Music Company

**Columbia Graphophone Company**  
Ditson & Company, Chas. H.  
Emerson Company.

**Enterprise Music Supply Company**  
Knickerbocker Talking Machine Company  
Plaza Music Co.  
The Aeolian Company  
New York Talking Machine Company

**OGDEN, UTAH**  
Proudt Sporting Goods Company

**OKLAHOMA CITY, OKLA.**  
Alexander Drug Company

**OMAHA, NEBR.**  
Harbour, Longmire Phonograph Company

**PHILADELPHIA, PA.**  
Emerson Company

**Girard Phonograph Company**  
Grafonola Shop, Inc.  
Hoath & Gorman  
Interstate Phonograph Co.  
Penn Phonograph Company  
Smith, Kline & French Co.

**PITTSBURGH, PA.**  
Buehn Phonograph Company  
Emerson Company

**Frederick Piano Company, W. F.**  
National Phonograph Co.  
Reed Company, Inc.  
Standard Talking Machine Company

**PORTLAND, ME.**  
Cressey & Allen

**PORTLAND, ORE.**  
Sherman, Clay & Company

**RICHMOND, INO.**  
Starr Piano Company

**RICHMOND, VA.**  
The Corley Company  
Crafts Starr Phonograph Company  
Haynes & Company, C. B.  
Roundtree Cherry Corporation

**SALT LAKE CITY, UTAH**  
Columbia Stores Company  
Salt Lake Hardware Co.  
The John Elliott Clark Company

**SAN FRANCISCO, CAL.**  
Sherman, Clay & Company

**SEATTLE, WASH.**  
Sherman, Clay & Company

**SIOUX CITY, IOWA.**  
Harger & Bilsh.

**ST. LOUIS, MO.**  
Associated Furniture Manufacturers

**ST. PAUL, MINN.**  
Dyer & Bro., W. J.

**SYRACUSE, N. Y.**  
Andrews Company, W. D.

**TORONTO, CANAOGA**  
His Master's Voice, Ltd.

**WASHINGTON, O. C.**  
Cohen & Hughes, Inc.  
Droop & Sons, E. F.  
Rogers Company, Robert C.

**WHEELING, W. VA.**  
Hillman Phonograph Company  
R. W. Tyler Company

**WINNIPEG, CANAOGA**  
Western Gramophone Company

**Universal Fixture Corporation**

**133 WEST 23rd STREET  
NEW YORK**



## QUARTERS FOR NEW OHIO JOBBERS

Victor Wholesale Organization Formed by W. T. Haddon, C. H. North and A. H. Bates Secures Commodious Quarters in Cincinnati

CINCINNATI, O., April 3.—The new Victor jobbing house organized in this city with William T. Haddon and C. H. North, both formerly connected with the Victory Talking Machine Co., and A. H. Bates, recently manager of the talking machine department of John Wanamaker, Philadelphia, as the principal factors, has arranged to start in business in May with headquarters at 427-429 West Fourth street, this city, in the building formerly occupied by the local branch of the Columbia Graphophone Co.

The new concern will operate under the name of the Ohio Talking Machine Co., it is said, and will take an important part in the distribution of Victor merchandise in Ohio and neighboring States. In view of the wide experience in the handling of the Victor product enjoyed by the three members of the new company, it is believed that the move will mean much for the general advancement of Victor interests in this section of the country, and particularly in the vicinity of Cincinnati proper.

It is declared that the additional wholesaling facilities offered by the new company in the Cincinnati district will be very welcome to the dealers, for they have been working under somewhat of a handicap in the matter of sources of supply. All three members of the new company were in Cincinnati during March, but two of them became ill and were forced to return East to recuperate.

## NOTED STARS HEARD IN CONCERT

Concert Under Auspices of Emerson Phonograph Co. Delights Large Audience at Forty-fourth Street Theatre, New York

A notable music event of the current season took place last Sunday, April 11, when a concert was given by famous talking machine stars at the Forty-fourth Street Theatre, New York, under the auspices of the Emerson Phonograph Co. At this concert these talking machine stars appeared in person, and it is a tribute to the popularity of these artists that "standing room" only was available when the concert started.

The artists appearing at this concert were Elizabeth M. Murray, songs and stories; Arthur Fields, baritone; Irving & Jack Kaufman, vocal duet; All Star Trio, instrumental; Mlle. Eva Leoni, soprano; Dolly Connolly and Percy Wenrich, songs and piano; Walter Scanlan, tenor; Ruby Wiedoeft, saxophone; Perry & Peppino, accordeonists; Plantation Jazz Orchestra; Emerson Concert Orchestra and Harold Sanford, musical director, overture, selections and exit march. The Emerson Concert Orchestra, consisting of thirty musicians under the able direction of Harold Sanford, accompanied the artists and "Tommy" Gray was the master of ceremonies.

All of these artists record for the Emerson library and the majority of them are exclusive Emerson artists. Their records have met with phenomenal success and at Sunday's concert they were compelled to render many encores in order to satisfy the audience. The dance numbers by the Plantation Jazz Orchestra and the All Star Trio were enthusiastically received, and in fact the concert was such a decided success that it is possible that another one along similar lines will be given in the near future.

## OPTIMISTIC OVER TRADE OUTLOOK

An increasing demand for Victor talking machines and records is reported by C. Bruno & Son, Inc., Victor wholesalers, New York—in fact it outdistances the merchandise available. Charles Bruno is decidedly optimistic regarding the future of the talking machine industry and predicts an expansion of business for Victor dealers, not only for this year, but for many years to come.



# International Talks

Every one of our Dealers make money when they sell our Emerson Foreign Records in

Polish  
Italian  
Hebrew-Jewish  
Bohemian  
Russian  
Scandinavian  
Spanish

Every Music Dealer in the country has a public that buys only the Best—and the "best" lies right in our

## Premier Catalogue of Grand Opera Violin Orchestral Band Novelty

selections by exclusive INTERNATIONAL artists—  
by artists who sing and play in your locality—by  
the Best

We are also

## Domestic & Foreign Distributors of Tonofone Needles

The Needle you will always use  
when you use it ONCE

and

## Globe Music Rolls

Both Word and Instrumental.  
"HITS WHEN THEY ARE HITS"

Emerson  
International  
Inc.

1780  
Broadway  
New York



# The Charming BEACON

*A Musical Masterpiece*

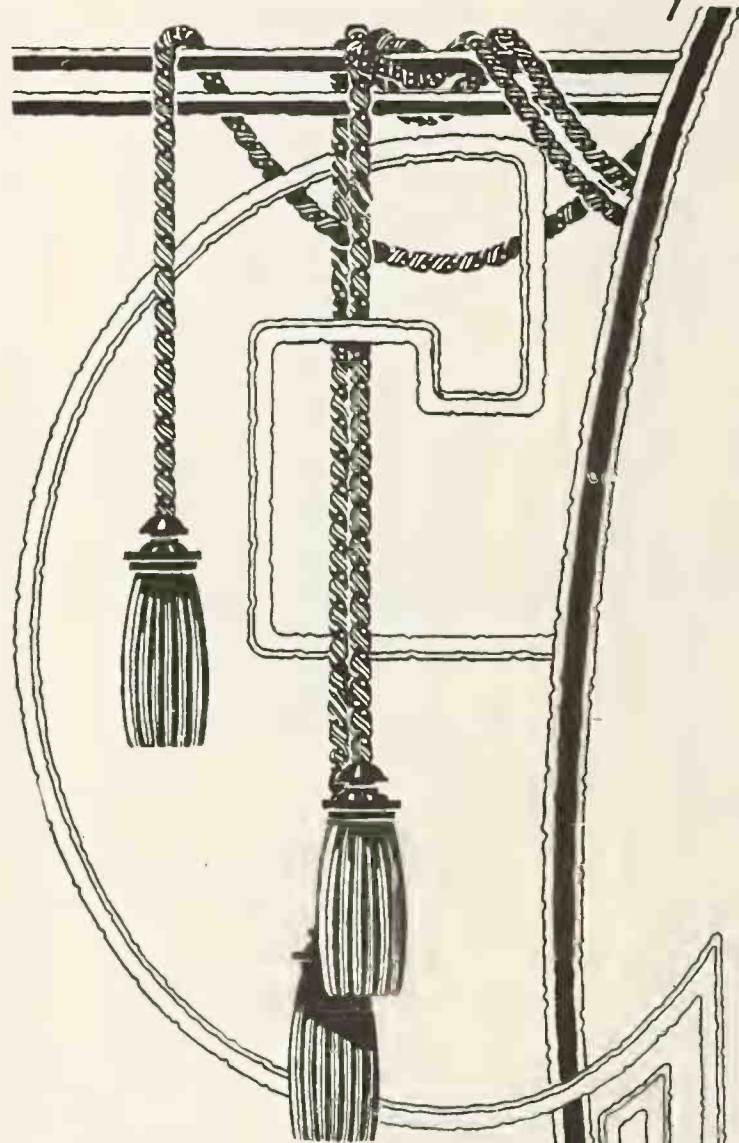

Patents Pending

Model No. 6, Price - - \$125.00  
Mahogany, Oak and Walnut

*This instrument is created for the better grade of dealer who desires to handle a phonograph that is distinctive and of unquestionable superiority to those now on the market.*

The Beacon tone is marvelously sweet, the cabinets of an exclusive design, and the motor and tonearm of the finest possible construction and workmanship.

There are four models, retailing from \$90 to \$225.

*PERIOD MODELS from \$375 to \$1500*

Dealers or jobbers, considering franchises for 1920, should send in their applications as soon as possible.

## Beacon Phonograph Company

19 Milk Street Boston, Mass.

*Factories at  
Somerville and Waltham, Mass.*

Western Representatives:  
Moeller-Waters, Inc., Lyon & Healy Bldg.,  
Chicago, Ill.



**NEW SONORA ELECTRIC SIGN**

Longacre Square, New York, Greater Center of Interest Since Appearance of Sonora Sign

There is a new Sonora electric sign on Broadway which is proving one of the most effective mediums that have yet been introduced in behalf of this well-known product. This sign is fea-

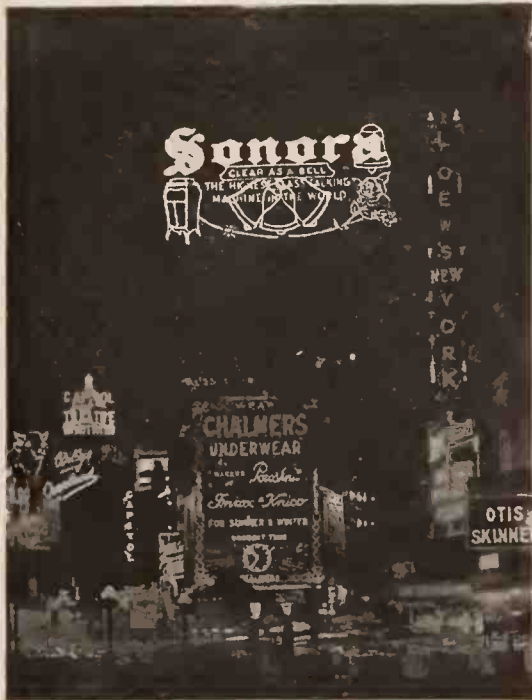

Sonora Sign at Longacre Square

tured at the base of the triangle of Longacre Square, which extends from Forty-second street to Forty-eighth street. It is considered one of the finest locations in the country, and the sign itself is exceptionally artistic. It is placed on top of the Universal Film building at Forty-eighth street and Broadway and by reason of its distinctiveness stands out from all the other electric signs on the Great White Way.

Beneath the words Sonora is the famous Sonora slogan, "Clear as a Bell," and underneath is the well-known phrase, "The Highest Class Talking Machine in the World." A giant bell swings ceaselessly from left to right. At the left is shown in red lamps against a red background one of Sonora's popular curved-side models, and at the right appears an artistic floral design.

**UNICO EQUIPMENT INSTALLED**

Complete Battery of Unico Booths Installed in the New Warerooms of the Beckwith-O'Neill Co., of Minneapolis, Minn.

In the March issue of The World reference was made to the new warerooms of the Beckwith-O'Neill Co., Victor wholesalers, Minneapolis, Minn. Through an error, the name of the manufacturer installing the booths, counters, etc., was incorrectly stated, for we have learned that the Unit Construction Co., of Philadelphia, has installed complete Unico equipment in these warerooms. An imposing battery of Unico booths, together with Unico counters, racks, etc., was ordered by Beckwith-O'Neill Co., and E. F. O'Neill states that an investigation of fixture lines convinced the company that the Unico system was the one the Beckwith-O'Neill Co. wanted, and these fixtures are being used exclusively.

**ACME-DIE**  
**CASTINGS**  
 ALUMINUM-ZINC-TIN & LEAD ALLOYS  
**Acme Die-Casting Corp.**  
 Boston Rochester Brooklyn, N.Y. Detroit Chicago

**NEW PARAMOUNT JOBBERS**

Peck & Hills Furniture Co. Become Distributors for Eastern New York and Pennsylvania, Delaware and New Jersey—Important Deal

The Peck & Hills Furniture Co., 141 Madison avenue, New York City, important factors in the local furniture trade, have been appointed distributors for the products of the Paramount Talking Machine Co., Port Washington, Wis., manufacturers of Paramount talking machines and records. This important deal was closed recently by W. P. White, sales manager of the Paramount Talking Machine Co., who visited New York.

The Peck & Hills Furniture Co. will cover as their territory eastern New York, eastern Pennsylvania, Maryland, Delaware and New Jersey. The company are well equipped to feature Paramount products to advantage, and their sales staff is enthusiastic regarding the possibilities of these machines and records in this territory. An active sales campaign is being arranged for.

**RECORDS BY HOMER RODEHEAVER**

Soloist with Billy Sunday Records Two of Evangelist's Hymns for Vocalion

Lest the music-lovers of the country forget that Billy Sunday is still with us, there appeared as one of the features in the Aeolian-Vocalion record list for April a record made by Homer Rodeheaver, whose splendid work as soloist with the evangelist is recognized throughout the country. Mr. Rodeheaver has recorded two of the best known of the hymns used by Billy Sunday, "Brighten the Corner Where You Are" and "I'm Coming Home; Mother's Prayers Have Followed Me."

**JERSEY CITY BRANCH STORE**

Newman's Music Shop, Jersey City, N. J., has opened a branch store at 92 Monticello avenue in order to extend to its customers in that section of the city the Newman service. Grafonolas and Columbia records are carried. The other store is located at 529 Jersey avenue.

**ANNOUNCEMENT EXTRAORDINARY**

**HOBSON'S**

(Trade-Mark)

**STEEL NEEDLE POINTER FOR TALKING MACHINE NEEDLES**



*Pays For Itself The First Year*

*Saves Needle Expense. Prevents Record Damage*

**Makes Ordinary Steel Needles Play Hundreds of Times**

—It Is Positively the Greatest Invention Since the Phonograph

The talking machine motor operates the needle pointer. It is small, simply constructed and practical in every way. Thousands of phonograph owners everywhere welcome this wonderful little necessity as a means of eliminating needle expense, record damage and the annoyance of running out of new needles. No phonograph is complete without HOBSON'S STEEL NEEDLE POINTER. Keep both your needles and records like new with the latest improvement on the market. HOBSON'S STEEL NEEDLE POINTER is guaranteed indefinitely. Retail price \$2.50 each. Liberal proposition to dealers and jobbers. Write for detailed information.

**The Hobson-Miller Manufacturing Company**

(Patentees and Sole Mfrs.)

LANCASTER, PENNSYLVANIA



"BUFFALO MEANS BUSINESS"

# IROQUOIS SALES CORPORATION

## TALKING MACHINES, RECORDS AND ACCESSORIES

10-14 NORTH DIVISION ST. WHOLESALE DISTRIBUTORS BUFFALO, N. Y.

# Okeh Records

### THE WINNING COMBINATION

(The Most Valuable Obtainable Agencies)

HIGH CLASS  
PROFITABLE

CLEAN CUT  
SUCCESSFUL

The increasing prestige and success of our lines indicate that

# Okeh Records

### "THE WINNING COMBINATION"

of the MASTER-TONE PHONOGRAPHS and OKEH RECORDS is proving the wisdom of our choice in selecting to offer our customers a *moderately* priced, soundly constructed instrument possessing the vital excellence of genuine TONE BEAUTY—together with what is without question the most remarkable and valuable opportunity the history of the trade has produced to build up, with OKEH RECORDS a permanent and profitable business with wonderful possibilities for future development.

### THE MASTER-TONE LINE

as offered today comprises four popular priced models of uniform, pleasing design, simple and acceptable to all classes of buyers.



Model 9—\$110



Model 11—\$125

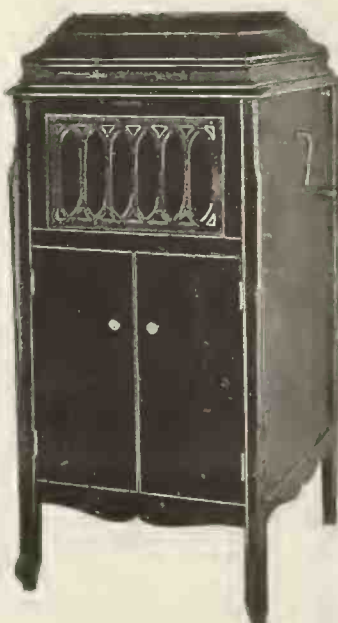

Model 12—\$150



Model 15—\$175

OKEH RECORDS are today accepted as the highest advance yet made in the art of reproducing with the least suggestion of the mechanical and the most faithful adherence to the original source—all vocal and instrumental music.

THEY STAND IN A CLASS BY THEMSELVES!

# Okeh Records

Price — ONE DOLLAR — Each

ORDER A SAMPLE INSTRUMENT, A SAMPLE (Box of 10) SELECTION OF RECORDS

TEST THEM

PROVE THEM

Let them "Speak for Themselves"

# Okeh Records



**FROM PICTURES TO PHONOGRAPHS**

How a Florida Photographer Has Registered an Impressive Success as a Talking Machine Dealer—Handles the Pathé Line

EUSTIS, FLA., April 2.—An impressive success in the retail talking machine business is that registered by B. G. Porter of this town, for within a year he has developed a business in Pathé machines and records that has forced him to secure much larger quarters. The results are particularly interesting inasmuch as the population of Eustis is only about 1,000.

Mr. Porter was enjoying a good photographic business a year ago, when a salesman selling the Pathé line called on him one morning when he was actively engaged in closing a transaction that would not make him over twenty cents profit. The salesman, noting this, inquired of Mr. Porter if he would be interested in a line that would make him twenty dollars on one sale instead of twenty cents. The sales-



B. G. Porter

man then went into detail, but Mr. Porter had been doing a business in dollars, not in hundreds of dollars, and naturally the idea of selling anything that cost a hundred dollars or over was beyond his wildest dreams at this time. However, after an hour's talk with the salesman and a demonstration of the machine, he decided to try them out, with a fear in his heart that he would be stuck with some talking machines and a big debt on his hands.

The machines came in in due time, and being a success in the photographic business in a small way, he decided to be a big success in the phonographic line—they looked so much alike in print. He unpacked the machines and put his demonstration machine right up near the door, picked out a good live "jazz" record and wondered if this was a good way to attract trade. Lo and behold, before the record was half played through there was a crowd in front of the door that looked mighty good to the man on the inside. A few of the spectators came

Perfect Uniformity and Uniform Perfection in

# Turntable Felts

You get just that in Turntable Felts made by the American Felt Company. That's why they are the choice of leading manufacturers in the Talking Machine trade.

Send us your specifications for felts for any mechanical purpose. They will have the attention of technical experts with laboratory facilities at their disposal

## American Felt Company

TRADE MARK

100 Summer Street  
BOSTON
114 East 13th Street  
NEW YORK
325 So. Market Street  
CHICAGO

in and inquired if he had such and such a record and requesting the playing of more records. That night he sold one machine for cash and from then on he was a huge success in the talking machine business.

He talked to every person he met about a machine, went out into the country and sold the country people records and machines; took a talker to the country dances and let the dancers hear and dance to the latest Broadway dance hits. Each machine sold brought him new prospects and now, one year after he placed his order for Pathé machines and records, he has a business that runs into thousands of dollars. He bought the property next to him recently and intends to remodel this into an exclusive music store. The phonograph and record business brought him new customers in the photographic business and now his store is headquarters for machines, records and photographic goods.

**ENGAGEMENT OF ETHEL M. LORD**

Daughter of George W. Lord of the G. W. Lord Co., Lynn, Mass., to Wed A. Miles Herrold

George W. Lord, of the G. W. Lord Co., Lynn, Mass., announces the engagement of his daughter, Ethel M. Lord, to A. Miles Herrold, of Everett, Mass. Miss Lord is a member of the firm and has been associated with her father for the past ten years in the Victrola business

in Lynn and to a large degree it has been due to her untiring efforts and her keen interest in the business that the G. W. Lord Co. has grown to be one of the largest talking machine stores in New England.

Mr. Herrold has been connected with the Travelers Insurance Co., as eastern Massachusetts representative for several years.

**FILES SUIT FOR DAMAGES**

Shelton Electric Co. Asks Damages of \$2,713,037 From Victor Talking Machine Co.

TRENTON, N. J., March 29.—Charging unlawful restraint of interstate commerce the Shelton Electric Co., of Chicago, to-day started suit in the Federal Court here against the Victor Talking Machine Co. for \$2,713,037 damages. The company asks \$1,000,000 damages for the alleged destruction of its business.

It is charged that the Victor Co. ordered all Victor dealers to cease handling the turntable motors of the Shelton Co. As a result the complaint alleges thousands of orders were canceled.

They say that in Albany there is agitation to add new Section 107 to the Transportation Corporation Law, making telephone companies liable to a penalty of \$10, in each case, for failure to respond to a telephone call within five minutes after proper signal is given.

**"Irene" in Lincoln, Nebraska  
"Roly Boly Eyes" in Bedford, Pa.**

Folks in Nebraska City have found out that Emerson Standard 10-inch Gold Seal Records furnish the right kind of inspiration for dancing.

Of course! Look at the musical organizations now playing for Emerson Records.



PLANTATION JAZZ ORCHESTRA  
EMERSON MILITARY BAND  
SANFORD'S FAMOUS DANCE ORCHESTRA  
EMERSON DANCE ORCHESTRA

GREEN'S NOVELTY ORCHESTRA  
THE SIX BROWN BROTHERS  
LOUISIANA FIVE  
THE IMPERIAL THREE

It's the same everywhere. Emerson dance hits have a way of getting dancers on the floor—and keeping them there.

A good way to pass up some nice easy money is to refrain from handling Emerson Records. But why refrain? Write us for facts.

**CARPENTER PAPER CO., Distributors Omaha, Nebraska**



# The Charming BEACON

*A Musical Masterpiece*

*The dealer franchise for the BEACON PHONOGRAPH is a valuable asset*

The BEACON embodies every desirable feature required to interest and maintain a profitable, high-class clientele.

Tone-quality, mechanical equipment and cabinet designs are exceptional, and the BEACON Dealer can welcome comparison with the recognized standard machines of the industry.

Five Standard Models \$90 to \$225.  
Period Models from \$375 up

*Our Dealer Proposition Will Surely Interest You  
Write for Details*

## ROBINSON & COMPTON CO.

Findlay, Ohio

*Beacon Distributors for Ohio,  
Eastern Michigan, Eastern Indiana  
and Eastern Kentucky*



Patents Pending

Model No. 6, Price - - \$125.00

Mahogany, Oak and Walnut



**ST. LOUIS REPORTS AN INCREASING VOLUME OF TRADE**

**Demand Continues to Exceed Supply of Talking Machines and Records—Cheney Distribution in Southwest Facilitated—Pathé Expansion—Tri-State Victor Association Meets—Other News**

St. Louis, Mo., April 8.—It is not a question of how good the talking machine and record business is in St. Louis, but how good it might be. It is good in the sense that there is a very good demand for both machines and records. It is not so good in volume of sales because everybody is short of the things for which there is a very good demand. Nobody attempts to estimate how good it would be if dealers had ample stocks. The situation in this respect cannot be said to be any better than it was last month. Right now it is worse, because there is an express embargo, which has been in effect three weeks. Distributors say they are getting more goods than in the past, but are very far from being able to supply the needs of the dealers. Many new accounts could be opened up, but the distributors are not going after new dealers because they are not able to satisfy the old ones. Promises are about the only things that are plentiful.

The manufacturers of the Cheney, which has been featured by Manager J. F. Ditzell of the Famous & Barr Co. music department during the Victor shortage, have just taken an important step to facilitate distribution in St. Louis and the Southwest. Arrangements have been made with the McPheeters Warehouse Co. for storage in St. Louis. Dealers in this city and the St. Louis trade territory can draw supplies from the warehouse instead of sending their orders to Chicago and incurring greater delay in delivery. The new arrangement went into effect the first of April. Manager Ditzell of the Famous & Barr Co., who recently returned from the East, says the Victor situation is not much changed, but he looks for improvement. Alterations now under way at the Famous & Barr Co. music department will provide greatly increased space and facilities for talking machines and records. A large part of the space now occupied by pianos will be given over to talking machine parlors and record counters.

E. C. Rauth, secretary of the Koerber-Brenner Music Co., Victor distributors, is on a trip to the Victor factory to see what the chances are for increased shipments.

W. H. Heiner, manager of the Pathé department of the Rice-Stix Dry Goods Co., is one man who hates to think what business he might be doing if he could get the goods. The Rice-Stix Co. took over the distributing agency for the Pathé product in September, but did not have enough goods until January to begin establishing agencies. The demand of the trade is for high-grade instruments, the higher the better, Mr. Heiner says. The firm has the agency for the entire Mississippi Valley and a branch has been opened at New Orleans for distribution in the Southern territory. It is in charge of F. S. Sims, formerly connected with the St. Louis establishment.

Manager McKenna of the Columbia Graphophone Co. is recovering at Indianapolis, Ind., from an illness with which he was stricken after the burial of his wife there. He is expected to return to St. Louis some time this month. A. W. Roos, who is in charge during his absence, says that the St. Louis wholesale department is getting more goods than formerly, but the demand keeps pace with the increased arrivals, and it is not possible to fill dealers' orders. The arrivals are pretty well distributed in the matter of styles, but the cheaper machines are the hardest to get.

The Columbia Co. recently put on a "Peggy night" at the Arcadia dance hall, with the cooperation of the Feist Co. and the B. Nugent & Bro. Grafonola department. A prize of \$5 was offered to the person who would identify "Miss Peggy" and repeat the Nugent slogan: "If it's in St. Louis it's here." A "Peggy" record, ten feet in diameter, was placed on the stage. The arrangements for the Columbia Co. were in the hands of C. R. Salmon.

The Field-Lippman Piano Co., in recognition of the increasing demand for records, is remodeling not only its St. Louis store, but its branch stores at Bonne Terre, Farmington, Flat River, Sedalia, Mo., and Fort Worth, Tex., so as to provide additional demonstration booths. The floor plans at each of the stores have been reshaped to provide a maximum of space for booths. The work has been completed at the St. Louis store and at Sedalia and Farmington.

The Artophone Co., now at 1113 Olive street, will move to the northwest corner of Eleventh and Olive streets as soon as the building at that corner, long vacant, has been made ready for occupancy. The building has a double front. It has not been decided yet whether the firm will occupy 1101 or 1103. The matter of remodeling the show windows was facilitated somewhat by the smashing of the plate glass by wind a few days ago. The company expects

to move within the next sixty days. As soon as 1113 is vacated the work of remodeling it, in connection with the store of the Baldwin Piano Co., next door, will begin. The Baldwin company will occupy both buildings.

Mrs. Mary Silverstone, mother of Mark Silverstone, president of the Silverstone Music Co., and mother-in-law of Myron Goldberg, vice-president and general manager of that company, died recently at her home, 5304 Maple avenue, after an illness of two months. She was about seventy years old. She owned considerable stock in the firm and was a member of the board of directors.

The Silverstone Music Co., the Artophone Co. and Widener's Grafonola Shop were among the fifty largest advertisers in St. Louis newspapers. During the past year the Silverstone Co. used 89,138 lines in the various St. Louis papers. The Artophone Co. used 49,384 lines. The Grafonola Shop used 40,415 lines.

The Tri-State Victor Dealers' Association held its annual meeting at the American Annex Hotel, with a large attendance from St. Louis

*(Continued on page 130)*



**Here Is the Most Profitable Phonograph Accessory**

The Repeatograph plays entire records or any part of them, over and over, as desired. Anyone can attach it permanently in place. Simply pressing on the motor spindle sets it in operation. Swings aside out of the way when not in use. No delicate parts or intricate mechanism.

Appeals to every phonograph owner and can be sold to almost every person who comes in to buy records. Ideal for Dancing, Dinner Parties, Card Parties and private receptions.

The Repeatograph works with the utmost efficiency on most all phonographs made.



HERE IS HOW IT OPERATES

**WARNING!**

The enormous success of the Repeatograph having stirred up some unfair competition, we hereby give notice that we are the sole manufacturers of all automatic repeating devices made, advertised or distributed under the original Eskil H. Josephson patent, No. 1218408, dated March 6, 1917, for a repeating attachment for sound reproducing instruments.

The trade is hereby given fair and reasonable warning that any advertisement or sale of mechanical record repeating devices infringing on the aforesaid patent will be prosecuted to the full extent of the law.

SEND FOR SAMPLE, WITH PRICES AND DISCOUNTS

**THE REPEATOGRAPH CO.**

NEW YORK 311 Hudson St. CHICAGO 664 W. Randolph St. MONTREAL 511 St. Catherine St. W.





# Crystal Edge MICA Diaphragms

THE STANDARD OF QUALITY AND SERVICE

PHONOGRAPH APPLIANCE CO.

109-113 West Broadway, New York

## BUSINESS ACTIVE IN ST. LOUIS

(Continued from page 129)

and from Missouri, Tennessee, Kentucky and Arkansas. H. A. Beach, manager of the traveling department of the Victor Co., was the particular guest of honor. He spoke on the interesting subject of production and promised more of it. Other speakers were Mr. Putnam and Mr. Ware, of the Putnam-Page Co., Peoria, Ill., Victor distributors. The old officers were re-elected, as follows: Val Reis, president; A. E. Parks, Parks Music House, Hannibal, Mo., vice-president; Theodore Maetten, Kieselhorst Piano Co., St. Louis, secretary, and Fred Lehman, Lehman Music House, East St. Louis, treasurer. J. B. Moran, Wurlitzer Co.; Charles Lippman, Field-Lippman Piano Co., and E. C. Rauth, Koerber-Brenner Music Co., were elected directors, succeeding E. C. Hammond, formerly manager of Vandervoort's music department; Joseph Hunleth, Hunleth Music Co., and J. E. Medairy, of the Grand Leader talking machine department.

The Connorized Music Roll Co. has closed a deal with the Starr Piano Co., of Richmond, Ind., to job the Starr talking machines and Gennett records, also made by the Starr Co., which the Connorized company has been handling for some time. The initial order was for \$10,000 worth of goods.

C. J. Woodward, special representative of the Emerson Phonograph Co., Chicago, spent the greater part of the past month in St. Louis. The Emerson records are handled here by the Famous & Barr Co. and half a dozen other firms. From here Mr. Woodward went to Kansas City. Eddie Cantor, the Emerson star, was here with the "Follies" during Mr. Woodward's stay. In a little speech he told the people they could get his records at the Famous & Barr store.

When Bertha Kalich came to town she felt that she could not be happy without an Aeolian-Vocalion, so she wrote the following note to W. P. Chrisler, manager Aeolian Co., which, of course, had the desired effect:

"My Dear Mr. Chrisler: I would appreciate very much if you would arrange to have an Aeolian-Vocalion placed in my apartments at the Jefferson Hotel for my personal use during my stay in St. Louis. Your new Vocalion records are remarkable. Won't you please include some of these? Thanking you in advance, I am, yours very truly, Bertha Kalich."

## JOINS VICTOR TRAVELING STAFF

Morris de C. Freeman, formerly with the Foley Advertising Co., has joined the traveling staff of the Victor Talking Machine Co. and has been assigned to represent that company in the State of Illinois.

## CELEBRATE FIFTH ANNIVERSARY

Owens & Beers, 81 Chambers street, New York, well-known Victor dealers, have been receiving the congratulations of their many friends in the trade upon the celebration of their fifth anniversary. The company started business on April 1, 1915, and during the past five years have built up one of the most profitable Victor clienteles in Greater New York. Both members of the firm are experienced talking machine men, and have concentrated all of their activities upon the Victor line. Their efforts have produced splendid results, and Owens & Beers are recognized to-day as one of the leading Victor retail houses in the East.

# Natural Voice Phonograph Co.

## ONEIDA, N. Y.



Style 175



Style 125

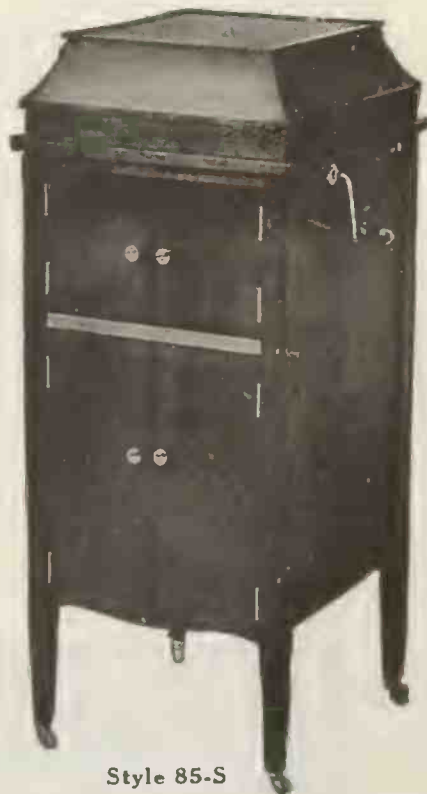

Style 85-S

Natural Voice is a splendid line of Talking Machines which will appeal instantly to your patrons. In fact, Natural Voice is as perfect as money can make it, and is worthy of its name and guarantee.

Natural Voice is the most remarkable musical instrument now before the public. For a full line of machines and price list, inquire.

## Natural Voice Phonograph Co.

### ONEIDA, N. Y.

Distributors of this Line  
Wanted in every State.

## "Does It Play All Records?"

Certainly MAGNOLA does; and without any extra attachments, too. This is only one feature, albeit a most important one, in the thoroughly up-to-date equipment of the MARVELOUS MAGNOLA.

### MAGNOLA "Built by Tone Specialists"



Watching the Music Come Out

May we send you our handsome illustrated catalog chock full of information concerning the wonderful construction system of Magnola and the beauties of its musical results, its artistic appearance and its moderate price?

Send your name and let us tell you more!

### MAGNOLA TALKING MACHINE COMPANY

OTTO SCHULZ, President

General Office  
711 MILWAUKEE AVENUE  
CHICAGO

Southern Wholesale Branch  
1530 CANDLER BLDG.  
ATLANTA, GA.



# Steinburn

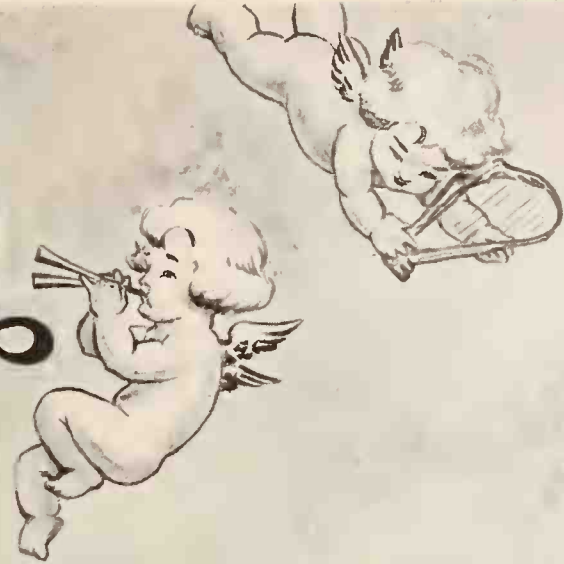
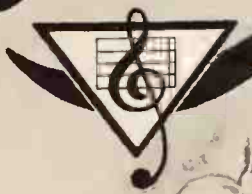

## 5-Year Guarantee Bond

The five-year guarantee bond with each Steinburn phonograph is merely evidence of the superiority of the Steinburn in every particular.

This bond covers spring motors, tone arms and cabinet. It is complete.

Steinburn phonographs are built by this old-established organization with the intent to endure competition throughout those years to come when supply will again be equal to demand.

Experience, facilities and ideals combine to make Steinburn phonographs most desirable from the standpoint of the *responsible* dealer.

Your Territory may yet be open, so write us immediately for catalog, prices and terms

### STEIN-BURN CORPORATION

Heyworth Building.

MADISON AND WABASH

CHICAGO

Eastern Distributors:  
A. M. DRUCKMAN,  
140 W. 23rd St., New York

*This is No. 70 Georgian period. The complete Steinburn line comprises 12 models, ranging from \$60 to \$300 list.*





# THE MID-WEST

WESTERN DIVISION OF THE WORLD, CHICAGO, APRIL 10, 1920. FAR be it from us to suggest that the opening of this department last month created any revolution in the views of our Mid-West friends towards us. The Western Division of The Talking Machine World is confident enough to believe that its friends think it sincere in trying to render adequate service to them. Among these possible services, surely the presentation of what we call the Mid-West point-of-view is not the smallest by any means. In this department we aim to let the talking machine industry know what is being said, thought and done by the most active men in the great territory which runs west from the Ohio Valley to the banks of the Big Muddy. The task is not small by any means, but it has its compensations. Members of the staff of this Division, as these words are written, are covering not only Chicago and its environs, but the States of Illinois, Wisconsin, Indiana, Iowa, Kansas and Nebraska. The present attempt to represent and make articulate the desires, needs and opinions of men who hail from within the wide boundaries of the middle empire, the imperium in imperio, of the United States, may be extremely imperfect. That it is being made is the important point. And it would be wholly wrong to suppose that we desire or intend to confine our vision to the territory which can be discerned with the unaided eye from the roof of the Republic Building. On the contrary, as readers will not fail to see this month, we propose to care for the interests of all the multitude of readers and advertisers within the vast lands over which the Western Division's representatives range. We shall be glad for criticism and still more glad for ideas. We exist to help; and, to work in the old saw, we aim to please.

Widening  
Scope of  
Observation

EVERY time one of our men goes to Milwaukee he comes back from that town feeling a stronger liking for it and for all that belongs therein. One of our men—no less a one than our own Carey—has just been up to the town of what-ever-they-call-Schlitz-now, to a convention of Wisconsin Columbia men; and he has come back with a very high opinion of the way in which the talking machine trade works together in those territories for the common good. Says our revered colleague: "Those Wisconsin guys are all to the custard. They work together. If one of them has a good idea he tries it out, and if it works as well as he expected, he passes it on to the bunch. Other cities might do worse than watch those fellows up there. Their team-work is ideal." Now that is very nice and we have the best reasons for believing it to be perfectly true. The music trades of Milwaukee have had for some time an association which has done all kinds of good work for the sake of all concerned. Their man who has so ably done the censor's work for them has now been promoted to a larger office in the National Association of Piano Merchants. All of which is very interesting. Wisconsin includes much lumber territory and has many large furniture factories. One can find an ideal locality almost anywhere within its borders for the establishment of a first-class talking machine plant. The spirit of the Milwaukee men is also very much the spirit of Wisconsin folks generally. They grow on one and one finds it hard to stay away from them when acquaintance has been thoroughly established. We are keeping a close watch on our Milwaukee and Wisconsin friends from out here in Chicago. There is a handy station off the North Shore Line almost at the door of our office and whenever he can one of us takes a little run up there. Incidentally our news-hound, Mr. Meyers, the gent who drops in and passes the time of day while he listens to all the exaggerated accounts of marvelous business deals which our busy trade friends hand out to him for transmission to the columns of The Talking Machine World, is a very nice man. Milwaukee readers are adjured to keep him well filled with news for the paper, so that thereby the fame of Milwaukee and of all Wisconsin men may increase mightily, not only in the West, but throughout the nation.

Carey's  
Wis-ful  
Words

WHEREBY we are reminded. We have down here in Chi. a gentleman by the name of Sebok. Our friend is in charge of the foreign record department of the big Western Columbia offices. He was up to the dinner of the Wisconsin Columbiads and had some things to say about foreign records in general which we rather suspect may have come as a bit of a surprise to some of his hearers. We have not a stenographic record of his talk, but in substance it was like this: "Some dealers, in fact a great many dealers, do not know how much money there is in handling foreign records. It must be done intelligently, of course; but if you will take the trouble to study the matter you will find that a foreign record trade is very profitable. It is more, too, than just this. For, little as you may have thought it, the foreign language record has done wonderful things in Americanization. And it will do still more wonderful things in the future. It is not necessary that you should speak the language of a foreign customer. Find out his nationality and then slip in a record to correspond. Let it be one of the folk songs or dances he knows so well and the music will sell itself. He will buy the record and perhaps one or two more and you may bank on it that he will soon come back for others. After a while he will begin to take notice of the American music. Give him encouragement as well as a little time and he will soon be a regular caller for the domestic, native stuff. If you are wise, you will see that he gets to hear some of the patriotic songs and orations, which sometimes seem such 'old stuff' to your native-born customers. Let him have some of these with him at home and you will be surprised how quickly he learns them off by heart. That sort of work is not only profitable, but it is patriotic; and every good American among the dealers ought to keep these ideas in mind."

Sebok  
the  
Sibylline

THE gentleman is certainly right. We talking machine men are no worse than men in other trades, we suppose. Every man tends to become so thoroughly penetrated with the rigors of his business that he has neither ability nor inclination to think of the hundred and one important side issues that depend upon it. It may seem absurd to say that the talking machine dealer has the opportunity to help powerfully in making the foreigner understand what America stands for and what it means to be an American. Yet it is even so. There is no need to repeat the story so well told by the expert whose remarks we have substantially reproduced above. But it is perhaps necessary to point out that the native citizen seldom stops to think that one of the reasons for the existence and propagation of radical doctrine among the foreign-speaking elements of the population is to be found in the simple fact that we have let them come over here and then have complacently assumed that they would be "Americanized" by the very act of living within the territorial limits of the United States. Of course the complacent fatuity of the notion that in some miraculous manner the "American spirit" would permeate these millions, shut off by the high barrier of foreign speech, has been disastrously exposed during the last year or two. The melting-pot does not melt. Of course not, for there never was a melting-pot. The foreign-speaking emigrant has not been assimilated. He has remained in a little enclave of foreign-speaking neighbors, often exploited, often cheated, doing better indeed than ever he could do at home; but never getting over the wall of strange speech and stranger custom. His children have gone to school and are soon "Americanized," even though perhaps the process has only been superficial. But he is out of it. We are just beginning to realize that there live hundreds of thousands among us who simply do not comprehend the meaning of America or of the ideals of democracy, who do not in the least understand those terms; hundreds of thousands speaking languages which we do not understand and dreaming dreams which are wholly alien to us. The "ignorant foreigner" is not to be blamed if his sole practical idea of our system is founded on his experiences with the policeman and the factory foreman.

Regarding  
the Non-  
Melting-Pot



# POINT OF VIEW

Americanization is a word with a thousand meanings. One of them is that we must find ways, popular and practical, for making the foreigner realize that America means something for him. We must begin by realizing ourselves that he has brought something to us from his distant home, something in the shape of music, art, culture, which we need and can use; while we must make him see that the great democratic problems which we are trying to solve can be brought to solution only when every element in the population, native and foreign-born alike, co-operates in harmonious effort. We have despised the man who speaks a foreign language. Yet this man has had the nerve to come across the ocean in search of better living conditions. We will not trouble to ask what treasures of culture he brings with him. Yet we make it as hard as possible for him to acquire what we call American culture. We allow him to be exploited in every imaginable way; yet we wonder why he does not become a loyal citizen overnight. We take as much from him as we can and we give back the minimum in everything. No wonder we have centers of radical teaching and a radical foreign press preaching revolution. How many of these men who came to find liberty have been led to believe that the new country is as little truly "free" as the old one ever was? Here is the problem of Americanization in its native aspect. Is it not plain, then, that our good friend of the Chicago Columbiads laid his finger on a point of contact between this great question and our industry? We can offer to the foreigner an unsurpassed means for acquiring an understanding of American ideas, in a way which no other agency can match. The records that he can take home and play over and over are weapons of surprising power. Let us develop our friend's suggestion into something systematic. Will the talking machine men's associations take the hint? *Verbum sat sapienti*, as they used to say in Rome.

SOME of our readers certainly—and all of them very likely—have noticed the rather striking form of publicity which is at present adorning the columns of this encyclopaedia over the style and title of Moeller-Waters, Inc. Now Moellerwatersinc is a big affair, in two senses. Both Moeller and Waters are large persons, large physically and otherwise. George Moeller is both large and impressive, while the other end of the combination is large and expressive. One impresses the beholder with a sense of achievement, large achievement naturally, while the other expresses constantly a large confidence in the future of the electric motor as applied to talking machines and talkers. Now we are of the reasonably sure opinion that the electric motor for the talking machine is about to come into its own. We do not for a moment suppose that the spring machine is to be swept off the map; far from it. But we do say that the electric motor is on the way, and coming fast. The fact is, as we have more than once remarked to both the ends of the M-W combination, the improvements which are coming within the next few years in the talking machine will make the past few years seem like ancient history. To which those personages have usually replied in the words of the poet, "jest so." Whether the discriminating reader shall detect in that terse phrase any suggestion that we are making jokes is another matter; but there is no doubt that our two earnest friends are equipped to put over more than one little proposition of the sort. George Moeller was a big man all his life, we reckon, and he used to be a very big man indeed in the very big house of Carson, Pirie, Scott & Co. Men of the sort we like to see in our industry. We have a tidy lot of sizable ones already out here in the middle territory, and we plan to have more. Youbetcha!

CHICAGO enjoys (if that is what you call it) the reputation of having founded the mail-order business and of still carrying it on as no other city ever has or is likely to. Chicago and her subordinate territory likewise have seen the foundation of the great independent talking machine industry in all its ramifications. Now it is our more or less humble opinion that talking machines and mail-orders don't

mix. At least the result of the mixture cannot be good for retail merchants. One of the very biggest institutions, which is, we believe, entitled to call itself the king-pin of the mail-order business, has been taking a great deal of space in our newspapers to advertise a line of talking machines at prices ranging from \$48 to \$195, on two weeks' trial, no money down, freight paid and from sixteen to thirty-two months' time to pay. With all due respect we beg to suggest that this is going a bit too far. It is bad enough to offer to sell on such long time. When the other considerations are added, the proposition begins to assume proportions that can only be called sinister. But this is not all. To anyone who knows anything of the margin on which manufacturing is being done it is obvious that the machines in question cannot be the highest class; yet they are advertised in the most positive terms as superior to machines selling at prices higher by from 25 to 50 per cent. This sort of statement is familiar to those who are in the game and we in the industry know how to discount it. But the public does not know and the net result tends to undermine public confidence in the stability of value for talking machines generally. The house which advertises these machines on these extraordinary terms and at these extraordinary prices says positively that 250,000 of them have been sold already. That is probably quite true. But what do the legitimate dealers think of this sort of business? Do they think it a joke? Or something that will soon pass away? If they think either they are mistaken. The newspapers which print such publicity need censors. But the fact is that our retailers are not organized to make any effective protest. The organized influence of the Chicago retail talking machine dealers is without doubt sufficiently great to insure the Chicago papers eliminating all questionable claims and misstatements inserted within the columns of the Chicago papers. This influence is not now a potential one and is not immediately available because the dealers are not united. What better argument for union and common action could be provided?

WHILE we are about it, there is just one more thing we want to gas about before the end of the page comes. Will the readers of this Hexagon of Humor and Whirlwind of Wit please note that our talented colleague, Nealy, of the A. E. F., has given in his Chicago news letter, on adjoining pages, a description of the salesmen's conferences which are being held at present in our fair city at the offices of the American Steel & Wire Co., under the auspices of the Chicago Piano Club? Now, the talker gents who read—as we hope they do anyway—these monthly inspirations (we did not say "desperations") will please note that they are invited every Friday. It is not a piano man's show exclusively. It belongs to all who dally commercially with the art of music, whether they sell pianos, talkers, mouth organs or horns. In selling any or all of them one is selling music; and at bottom there is precious little difference in the sentiments which are aroused and the desires which are stimulated. Then, of course, in a host of details, as well as in principles, the problems of the talking machine salesman are like those which perplex his piano-selling brother. It has been pleasant to note that some talking machine men have already conquered their natural timidity sufficiently to venture among the lions of the piano trade, seeking not, though perhaps expecting, to be devoured. They report that a good time was had by all. The selling of the talking machine is so emphatically a selling of music that the intelligent salesman recognizes the necessity for founding his whole method on this basis. Then again, the record is so vast and important a factor that there is no possibility of leaving it out of consideration. The conferences to which we are now referring are considering every aspect in the great business of selling music to the American people. They are trying to discover principles on which methods may be based. They are having great success. But they ought to be supported by the practical wisdom of talking machine salesmen. May we suggest that when this journal reaches its readers they will resolve to attend on April 16th and every Friday thereafter.

Two  
Large  
Gents

Messieurs  
Les Con-  
ferenciers

Some  
Bad  
Stuff



**East and West**

**NEW YORK  
TALKING MACHINE C<sup>o</sup>  
CHICAGO**

**Exclusive  
Victor Wholesalers**



# From our CHICAGO HEADQUARTERS

REPUBLIC BLDG., 209 SOUTH STATE ST TELEPHONE WABASH 5774

EDWARD VAN HARLINGEN

WILLIAM BRAID WHITE

EUGENE F. CAREY

ARTHUR E. NEALY

A. SNYDER

CHICAGO, ILL., April 8.—In a recent talk before the Advertising Men's Post, of the American Legion, L. J. Boughner, classified advertising manager of the Chicago Daily News, brought up some points of acute interest to the talking machine trade of Chicago. This was in connection with recent efforts by certain organizations of this city to curtail the advertising of "luxuries," such as musical instruments. Mr. Boughner condemned rightly this advice as a short-sighted attempt, calculated to reach the surface and not the heart of the trouble. In the first place, we, of the talking machine industry, should insist that talking machines are not luxuries, but are necessities as the widespread purchase of them by families of small means has indicated, and in the second place, the extravagance of the purchasing public in its demand for luxuries is a result and not a cause, and the cause cannot be cured by applying the remedy to the result.

Talking machine men may ask, "What has this to do with us?" claiming that talking machines not being a luxury, it is not applicable to our trade. True, but that is exactly what we have got to prove to others. We should base our selling appeal more upon the definite beneficial effects to be derived from the purchase of a talking machine, instead of extending ourselves to picture the pleasures obtainable therefrom. The pleasures are great, but the benefit resulting from these same pleasures is that type precisely calculated to mar and not enhance the spirit of public extravagance which we would seek to lessen. The public as a whole has a wrong conception of music, due entirely to the attitude which salesmen in the past have taken with customers; and it is this misapprehension which must now be combated by the trade. As a prominent Chicago music man recently stated, "The duty of the salesman is not to sell the talking machine, but to justify the purchase in the mind of the customer—the highest ideal for which we work, and the one based upon the soundest business principles for trade permanency."

The slight curtailment in the past month in retail newspaper advertising of talking machines is not, we believe, due to any such cause as Mr. Boughner has stated. The talking machine season is waning as Summer approaches,

and there is bound to be less advertising, but his warning is a good one and might well be considered by the trade.

### New Removal Ordinance

An ordinance of great interest to all firms who do an instalment business has been passed by the City Council of Chicago and should be read by all retail talking machine merchants. At a meeting of the Piano & Organ Association of Chicago this ordinance was discussed at length, and its workings explained, by Frederick Rex, head of the Municipal Reference Library, who has charge of its enforcement. The meeting was held on March 25 at the Chicago Automobile Club and the ordinance was presented in full to the assembled music men. Sections one and two of the ordinance read:

"Be It Ordained by the City Council of Chicago:

#### SECTION ONE

Every person, firm or corporation owning or operating any moving van, furniture car, transfer wagon, express wagon, delivery wagon, or any other vehicle engaged in moving or hauling for hire in the city of Chicago, shall keep a record of the place from which and the place to which he or it moves the household goods or personal property, or any of them of any person who is, or persons who are removing or vacating any dwelling, house, flat, room, rooms or place of residence, abode or place of business in the city of Chicago, which record shall show the name and address of the mover, the name of the person for whom the moving was done, the name of the person who was the owner or ostensible owner of the said household goods or personal property moved, the address from which in the city of Chicago and the place to which in the city of Chicago or outside of the city of Chicago, as the case may be, such moving was done, and the name and address of the common carrier to whom such household goods and personal property were delivered with the date of such removal or delivery and the character of the articles moved.

#### SECTION TWO

Any person, firm or corporation operating any of the vehicles aforesaid, and any person, firm or corporation not engaged in moving or hauling for hire in the city of Chicago but in control or possession of any of the vehicles aforesaid . . . shall not later than Monday following the date of such moving file in the office of the Bureau of Statistics and Municipal Reference Library of the City of Chicago, or send by registered mail to such bureau a full, correct statement of all such hauling or moving done containing the information as required in Section One hereof. Upon receipt of such statement the head of such Bureau of Statistics and Municipal Reference Library shall keep a record of all such transactions in a book or books, or other suitable form of maintaining records to be used for that purpose with an alphabetical index of the names of the persons for whom such moving or hauling has been done. Said register shall not be open to the public but the head of such bureau shall

furnish to any person inquiring therefor, information as to any particular change or removal, for which a charge of fifty cents shall be made for information concerning each change or removal."

In commenting upon the above ordinance, Mr. Rex, who will be in charge of the registers, said that if the ordinance is to be effective and a benefit to business it must be strongly supported by the various trades, otherwise it will fall into disuse. Mr. Rex showed that while the ordinance is of prime importance to houses doing an instalment business, it also will benefit the public and community in general. The police department will undoubtedly make use of it, as will also the Health Department, the Post Office Department, the county sheriff and the bailiff of the Municipal Court. Similar ordinances have been passed in the cities of Dayton, Detroit and Jersey City and have proved considerable of a success.

"Forms for the filing of such records are now being prepared," said Mr. Rex, "and we expect to be ready to function by the middle of April or first of May. It is expected that forms will be ready soon for distribution to movers."

Wm. Wade, of the Wade Talking Machine Co., who has taken an active interest in securing the passage of the bill, spoke on its value to all musical instrument houses, relating also the many difficulties that were experienced in pushing the ordinance through the City Council. Seventy-five thousand removals were estimated to have taken place last year, a number of which were "dead beats," he said, thus showing the value of the ordinance in future years to all branches of the music industry.

### The Moving Strike

Thursday, April 1, Chicago musical instrument movers went on a strike and tied up deliveries of musical instruments to a great extent. For a week previous to this, the Chicago teamsters, Local No. 711, were on strike, making it impossible to move any sort of goods from one house to another. The commercial movers, Local No. 1738, however, did not go out until Thursday.

### Starr Co. Invades Loop

Wholesale and retail offices of the Starr Piano Co. will soon be ready for occupancy at 423 South Wabash avenue. The concern has removed its retail store, located at 1228 East  
(Continued on page 137)

## Use Your Own Judgment!

Here is a fact:—

*The Wade Fibre Needle Cutter* was on the market long before any other Cutter was ever advertised. Almost everybody knows that *The Wade Fibre Needle Cutter* is not alone the ORIGINAL, but after all the most dependable Cutter on the market.

Obviously, "The Wade" gives better and longer service, as we use only the very best of materials and workmanship that money can procure.

When you buy *Fibre Needle Cutters*—just use your own unbiased judgment, buy the original and the best—and you will have no occasion to be sorry about it in the long run.

"THE WADE"—A CUTTER WITHOUT A RIVAL IN APPEARANCE AND CONSTRUCTION, TRIED, TESTED AND PROVEN TO BE THE ORIGINAL AND THE BEST.

### OUR MOTTO:

"Not how Cheap but how Good"

# WADE & WADE, 3807 Lake Park Ave., Chicago, Ill.



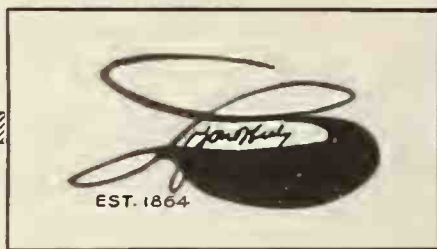

# *The Leading* Victor Dealer

In every community there is a leading Victor Dealer; to him this advertisement is addressed.

Years of specializing on Victrolas has enabled us to build up a series of dealers' helps, which has the endorsement of many of the country's largest music houses.

This advertising is available for your use. It is proven advertising which makes good. It meshes in directly with the big national advertising of the Victor Co.

## Lyon & Healy, Victor Dealers' Advertising

**Victor Newspaper Advertisements**

52 advertisements per year, complete with copy, proof sheets and matrices at \$8.33 per month. The pioneer advertising service in the Victrola field. Many of our subscribers started when the service was first issued 5 years ago and are still with us today.

**Half Newspaper Service**

Half of the service described above, 26 advertisements per year, \$4.17 per month.

**Victrola Record Art Folder**

Pronounced by many to be one of the most attractive pieces of lithography ever produced. Beautifully lithographed by the Off-

Set process in color. Use these instead of envelopes for mailing the monthly supplement. Prices on application.

**Victrola Record Art Window Cards**

Four strikingly printed colored window cards illustrating four records of the new release each month. They dress up your store or window. \$2.00 per month.

**Big 24 Sheet Posters**

Lithographed in colors. Choice of several designs. Ask for samples and prices.

**Silent Salesman Display Racks**

12 panelled display racks listing standard records. Price \$9.00.

Tear Out This Page, Mark the Square Before the Service in Which You Are Interested and We Will Send Samples Without Charge.

# LYON & HEALY

## Victor Distributors

### CHICAGO



FROM OUR CHICAGO HEADQUARTERS—(Continued from page 135)

Sixty-third street, to the more central location, and plans are being laid for considerable expansion in its Chicago business. C. O. Miller, with the company for twenty years, will be in charge of the wholesale end of the business, and Henri Rousseau, formerly connected with the Adam Schaaf Piano Co. and the A. B. Chase Piano Co., has joined the Starr forces and will be in charge of the retail department. Mr. Rousseau has taken charge of the present South Side store, where he will continue to be located until alterations on the Loop building are completed.

In the two above-named men the Starr Piano Co. gives its Chicago office two enthusiastic and capable workers. Considerable money will be spent to make the wholesale and retail offices complete and up-to-date in every way, and before long it is expected that Starr talking machines and pianos will have a strong representation in Chicago's busiest section.

**Remove to New Offices**

Drying Systems, Inc., of Chicago, manufacturers of equipment for drying varnishes, etc. will remove their offices and factory from 342 N. Michigan avenue, to 11-17 S. Desplaines street, on May 1. With increased forces and more favorable working conditions they expect to increase their output considerably, and as they will be in the center of their source of supplies they are sure that present deliveries can be facilitated. The great demand for equipment of rapid drying, also the great demand for the latest development, the drying unit, has necessitated the change.

**Lakeside Pacific Coast Representative**

The Lakeside Supply Co. is very fortunate in securing the services of Merten Corwin as Pacific Coast representative. He is a college graduate and has been affiliated with the electrical field for the past twenty years.

Mr. Corwin has traveled the Pacific Coast for a number of years and is familiar with the needs of the people. He will specialize on elec-

tric phonograph motors and completed, electrically driven machines, besides selling the Lakeside entire line of motors, tone arms, hard-



Merten Corwin

ware and accessories and will no doubt carry a small stock for immediate shipments.

**Elaborate Marvelon Catalog**

Something distinctly new in talking machine catalogs has been evolved by the Marvelon Talking Machine Co., of St. Louis. Instead of the conventional booklet the company has prepared a series of cards containing photographs of the

different models. The cards are not bound together, but each one is separate, and the whole is not bound together, but slips into a folder in precisely the same way that a photograph does. Highly artistic paper stock and appropriate type have been used, giving an effect of quality unsurpassed. Four cards, each with a photograph of a particular type of the Marvelon, open and closed, are in the series.

The catalog has been prepared at the instance of Nat Steiner and well indicates the merits of the instrument and high quality of trade to which this concern appeals. To supplement this catalog the company has issued a smaller twelve-page folder of their complete line.

**D. C. Blum With Superior Phonograph Co.**

D. C. Blum, formerly manager of the wholesale department of the Wade Talking Machine Co., of this city, and well known in the talking machine trade, is now associated with the Superior Phonograph Co., 320 South Wabash avenue. Mr. Blum is connected with the sales promotion division of this company and according to his present plans an intensive merchandising campaign will be inaugurated in the near future in behalf of the company's products.

The Superior Phonograph Co., in addition to manufacturing the Melotone phonograph, also carries a line of record needle cutters, fibre needles, record brushes and practically all standard accessories. The concern has met with pleasing success in the introduction of the Melotone talking machine, and distributors and dealers have been appointed in many of the leading trade centers.

**Demand for Repeater Stop**

Since the advent of the repeater stop on the market it has had a remarkable success. That such a refinement constitutes a strong selling factor is the decision of the many manufacturers who have adopted it as standard equipment. The actual manufacturers of talking machines as

(Continued on page 138)

**Your Account With Us**

Lateral  
Cut

**Okeh  
Records**

Lateral  
Cut

**Will Be an Insurance Policy Against  
EMPTY RECORD SHELVES                      LOSS OF CUSTOMERS  
LOSS OF PROFITS**

**Record Dealers Reach the Acme of Wisdom  
WHEN THEY STOCK UP WITH POPULAR HITS ON**



*No Waiting for Delayed Shipments When You Order From Us*

**MAGNOLA TALKING MACHINE COMPANY**

711 Milwaukee Avenue

OTTO SCHULZ, President

CHICAGO, ILL.





# NEWMAN BROS. PHONOGRAPHS

No. 2

Unusually pleasing in tonal qualities as well as in appearance.  
 Finish: Walnut, Mahogany, Oak      Height: 50 inches.  
 Plays five 10-inch records. Noiseless in winding. Plays all records. Automatic stop.  
 Tone Modifier. Other special features we shall be pleased to point out.  
 You will be pleasantly satisfied with our line of phonographs.  
 For your convenience and because of increased business, we have opened an office  
 and display rooms in the FINE ARTS BUILDING, CHICAGO.

## Newman Bros. Co.

Makers of Newman Bros. Pianos, Players and Phonographs  
ESTABLISHED 1871

OFFICES AND DISPLAY ROOMS: THE FINE ARTS BUILDING  
**410 SOUTH MICHIGAN BOULEVARD CHICAGO**

### FROM OUR CHICAGO HEADQUARTERS—(Continued from page 137)

well as dealers and jobbers have been asking for the little device, and many have gone so far as to make minor changes in the shape of their tone arms and reproducers in order to facilitate the use and quick application of the repeater stop.

The outstanding advantage of the repeater stop lies in the lever regulating feature. It can be set to re-play a record once, twice or three times, or constantly, if so desired, and after the rendition of one, two or three selections, the turntable is forced to come to a stop by an automatic brake. The latter is positive and built like a brake on an automobile. The leverage is equivalent to a pull of ninety pounds; in other words, it is said it will stop a turntable ninety pounds in weight when it revolves at full speed. The instrument works very much like a clock. The mechanism is noiseless and built to withstand long use. It is guaranteed for one year.

Perhaps the most indispensable use of the repeater stop is in connection with dance records. It has been said that 90 per cent. of the owners of phonographs are dancers. When these come to know the extent and advantages of such a repeating device, most, if not all, will undoubtedly equip their machines therewith.

The Repeater Stop Co. is operating as exclusive manufacturer and sales distributor for the instrument for the entire world, and is licensed under the Smith and Adams patents as follows: Smith Patents, 1060955 and 1062369. Adams Patents, 1275823, 1317257, 1317258, 1317259. Canadian Patent, 171377.

#### New Edison-Pathé Needle

The Red Seal Needle Corp., of this city, has produced and placed upon the market a new type combination talking machine needle, which serves reproduction purposes on Pathé and Edison machines. It is called the "twin jewel needle," and consists of a sapphire ball and

sapphire point mounted in one shank, thus eliminating constant changing of needles for playing both Pathé and Edison records, as has heretofore been necessary. Just a half turn of this needle brings the correct playing point into contact with the grooves of the desired record. The Red Seal Needle Corp. manufactures the "twin jewel needle" in two styles—loud tone, set in brass; half tone, set in fibre.

#### Now the "Dry-Ola"

Wm. Wade, of the Wade Talking Machine Co., has hit upon a novelty in the way of talk-



Immortalizes the New "Dry" Era

machines, particularly appropriate just at the present time. He has purchased the barrel stock in a local brewery, consisting of 2,000 one-quarter barrels, and has equipped them with all the essentials of a talking machine, motor, tone arm, turntable, amplifier, etc. Of course one of the greatest features of the "Dry-Ola" is

offered by its window display possibilities; but it is also a great little seller, as is evidenced by the Wade Talking Machine Co.'s sales of it. One of the "Dry-Olas" sold to the Illinois Athletic Club has been doing duty from morning to night, entertaining the members with selections apropos the present "dry" period.

Mr. Wade says he is sending one of the instruments to the chairman of the congressional committee that pushed the dry legislation through the House, and also one to Governor Lowden of Illinois.

#### Manager for Smith Piano Co.

A. J. Sharpe, formerly proprietor of the talking machine store located at 359 W. Sixty-third street, has disposed of his business to accept a position as manager of the talking machine department of the Smith Piano Co., at 311 S. Wabash avenue.

A few weeks ago Fred M. Firestone, manager of the city sales division of the Lyon & Healy piano department, resigned his position to become general manager of the Smith Piano Co., and it was through his efforts that Mr. Sharpe was induced to take over the management of the talking machine branch of the Smith Piano Co.'s business.

#### Price Should Have Been \$10

In the last issue of The Talking Machine World it was stated in speaking of the new Vitrola electric signs for the use of dealers that these were sold to the trade at a cost of \$100. This was a mistake. The cost should have been given as \$10.

#### Shines a la Mode

On the South Side, at Ashland avenue and Sixty-third street, there is a shoe-shining parlor called the "Victrola Shoe-Shining Parlor." A feature which attracts trade, and lots of it, is the talking machine music which entertains customers while their shoes are being polished.

(Continued on page 141)

# TRANSFER NAME-PLATES

We make the Transfer Name-Plates and Trade-Marks for the largest talking machine manufacturers in this country and for dealers in every state.

YOUR NAME, Mr. Dealer, on every machine brings the owner back to you or records and his friends to you for a machine.

Samples, Suggestions and Sketches Furnished Free

## THE MEYERCORD COMPANY, CHICAGO

Largest Manufacturers of **DECALCOMANIA** Transfer Name-Plates





# STEGER

*The Finest Reproducing Phonograph in the World*

The world's greatest artists, singers and musicians are at their best when they entertain you with a Steger Phonograph. It plays all disc records *correctly*, with no change of parts.

Steger Phonographs are sold at universal prices. The Steger Phonograph factories make every part of the Steger Phonograph complete.

### *Steger Wholesalers*

**EMERSON RECORD SALES CO., Inc.**  
6 W. 48th St. New York, N. Y.

**IVER JOHNSON SPORTING GOODS CO.**  
155 Washington St. Boston, Mass.

**STEGER & SONS PIANO MFG. CO.**  
867 Broad St. Newark, N. J.

**JONES BROTHERS CO.**  
317 Main St. Jacksonville, Fla.

**SMITH & NIXON CO.**  
306 Walnut St. Louisville, Ky.

**HALL MUSIC CO.**  
246 Pine Street Abilene, Texas

**WARFIELD PRATT HOWELL CO.**  
Des Moines, Ia.

**COLORADO BEDDING CO.**  
2nd St. and Grand Ave. Pueblo, Colo.

**CAMPBELL PHONOGRAPH SALES CO.**  
60 East S. Temple St. Salt Lake City, Utah

**STEGER & SONS PIANO MFG. CO.**  
Steger Building, Chicago, Ill.

MODEL 506 \$280

MODEL 505 \$210

MODEL 504 \$190

MODEL 503 \$155

MODEL 502 \$140

MODEL 501 \$110

MODEL 507 \$360

MODEL 500 \$90

MODEL 508 \$410





## In Your Store It Will Do This:

*First*—**ATTRACT** customers by its very novelty.

*Second*—**PLEASE** customers by its pure artistry of design.

*Third*—**SURPRISE** customers by its ingenious method of operation.

*Fourth*—**APPEAL** to customers by reason of its usefulness.

And last and most important of all

### The “**FAIRY**” Phonograph Lamp

**ASTONISHES** and **DELIGHTS** by reason of its mellow, voluminous tone, due to a newly patented sound amplifying chamber radically differing from the conventional designs, constructed of correctly jointed and suspended **WOOD**.

Electrically operated and equipped with a specially designed invisible switch, regulator and tone modifier.

No matter how high-grade the instruments you handle, the “**FAIRY**” phonograph lamp, musically and artistically, is equal to the best.

The best testimonial to our product is the fact that sales of the “**FAIRY**” have required our maximum output ever since its appearance in 1918.

**ENDLESS-GRAPH MANUFACTURING COMPANY**

Factory Address:  
4200 W. Adams Street

CHICAGO, ILL.

Downtown Salesroom:  
435 South Wabash Avenue

Michigan and Ohio Jobbers, FAIRY PHONOGRAPH LAMP CO., 10 Washington Boulevard, Detroit, Mich.



FROM OUR CHICAGO HEADQUARTERS—(Continued from page 138)

But another shoe-shining emporium on the North Side goes this one better. It features dancing a la talking machine for customers who have to wait their turn to mount into the chairs. The "parlor" is owned by one Robert Logan and is opposite the North Shore Hotel, Evanston. Logan bought some records and now gets all the trade of the Northwestern co-eds, who can dance or listen to operatic airs while waiting to have their shoes fixed up. Shines a la mode offer the enterprising dealer in every locality a chance to make a sale of a talking machine to his favorite boot-black. Show him this article, which tells about Robert Logan and see if he doesn't come across.

**Visits Federal Factory**

H. Schlaes, of the Schlaes Phonograph Co., of Omaha, Neb., and Council Bluffs, Ia., was a visitor to Chicago this month. Mr. Schlaes represents the Federal Phonograph & Supply Co. in the States of Nebraska and Iowa and was in Chicago for the purpose of visiting the factory headquarters here. He has made arrangements for goods to carry him through this season and is now securing samples of the Federal line to be placed in his offices at Omaha and Council Bluffs.

**Lyon & Healy Retail Service**

Lyon & Healy retail talking machine record service is known to many in the trade as being one of the most modern, efficient and pleasing in the country. The advantages of Lyon & Healy record service to the Chicago public have been featured by this company in retail advertising of recent date. In one of their ads the following is said, which we print because in it may be found ideas applicable to other dealers in their retail newspaper publicity:

"Since the earliest days of the talking machine we have been studying how to serve the public in the matter of records. We have found that the careful training of sales people, after the Lyon & Healy idea, has a great deal to do with record-buying satisfaction. It is a business of

infinite detail and we have worked out a thousand improvements. As an example: When you enter a record demonstration parlor in Lyon & Healy's and close the door behind you a felt damper attached to the door moves over into place and makes the room really sound-proof.

Then when you want records of a particular sort, they are brought to you promptly. The

sales person can furnish this service to many different customers in a day only through a solid knowledge of music and of the best records to be found in the Victor catalog.

"Our telephone service is unique. The young women who attend to the special record switch-board have before them complete lists, together with fresh special information of every kind."

(Continued on page 143)

J. E. ROBINSON                      ESTABLISHED 1879                      M. J. DECKER  
 TEL. HARRISON 420

**ROBINSON THE PLATER**  
*Platers to the trade — Gold our Specialty*  
 500 W. VAN BUREN STREET  
 CHICAGO

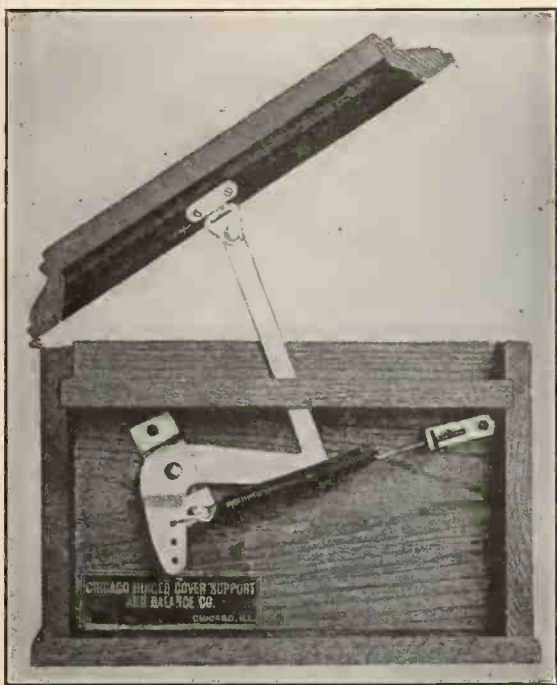

**COVER BALANCE No. 1**

Two Patents Dec. 9, 1919—One Patent Dec. 12, 1916, and Others Applied for

**Chicago Hinged Cover Support and Balance Company**

TELEPHONE PROSPECT 250

2242-44 W. 69th St. CHICAGO, ILL.

**READ THIS**

A cover balance is not a piece of hardware that can be applied to a talking machine cover in most any way and work fairly well. Owing to the different sizes and weights of covers and the different ways of making cabinets the sizes of springs and direction of pull must vary so it becomes a problem in engineering to design a support which will act properly on your machine.

We furnish diagrams and if you are a manufacturer and will give us the proper information:—

We will design a balance which we guarantee will work satisfactorily on your machine.

We will furnish you a sample to try.

We will furnish a blue print showing how to apply correctly—**AT NO COST TO YOU!**

When a balance is applied at one side, as it is in most cases, there is a tendency to warp or twist the cover so it will stand open on one corner.

We have overcome this trouble so that if our support is applied according to our blue prints

**OUR BALANCE WILL NOT WARP THE COVER**

**NOTICE OUR TOP CONNECTION, WHICH ADJUSTS ITSELF TO ANY BEVEL WITHOUT BENDING!**



# Blood

TONE ARM & REPRODUCER

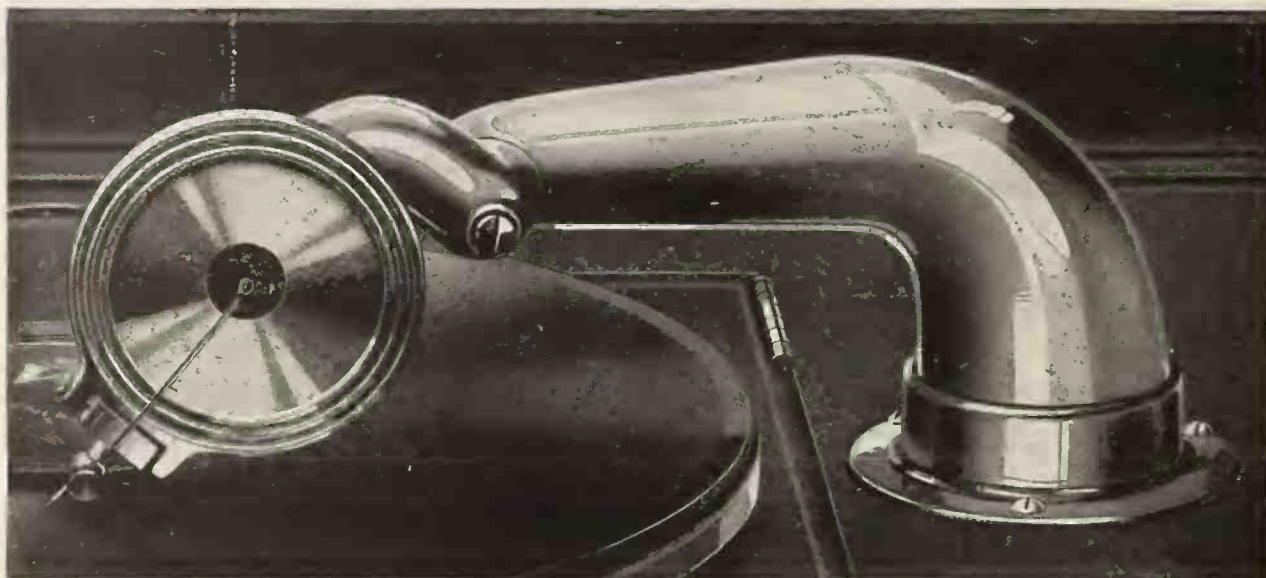

### CRITICS SAY:

“Most important improvement in Phonographs during recent years”

PHONOGRAPH manufacturers have long realized the utter inadequacy and deficiency of the present so-called tone modifier, which merely muffles or chokes the sound at entrance to tone chamber. Tonal vibrations are retained within limits of arm, causing excessive vibrations, with their resultant distortion of sound waves, harsh and indistinct tones.

NO OTHER REPRODUCER HAS IT

#### NOW THE BLOOD MUTE —

Eliminates all the objectionable features of the “choker” device, and makes possible perfect sound reproduction, which can be modified to a softness and clearness that are really remarkable. Retains high tonal quality of BLOOD reproducer.

#### HERE'S WHAT THE “BLOOD” ACCOMPLISHES:

Perfect regulation of volume while the record is being played, without in any way changing character of tone.

Enables you to build tone chamber flush with motor board and makes possible air-tight tone chamber construction.

Eliminates “choker” device and reduces manufacturing costs.

Gives you a phonograph of unexcelled tonal quality.

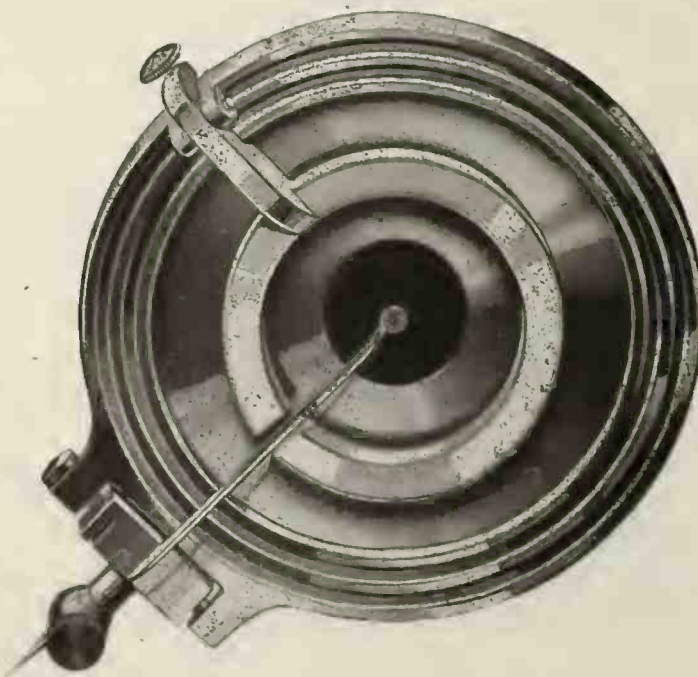

SHOWING BLOOD MUTE

*Designed and patented by Burr Blood and used exclusively in the  
BLOOD TONE ARM AND REPRODUCER*

## JEWEL PHONOPARTS CO.

59 E. VAN BUREN STREET

CHICAGO, ILL.



**Manufacturers, Assemblers, Jobbers and Big Dealers, let me help you solve your problems of buying and selling phonographs. My selling cost is the lowest of any agency in America.**

Cabinets only will be furnished to big users at a guaranteed saving of 10%.

**Line No. One:** A line of cabinets 48" high, ranging in price from \$25.00 to \$35.00.

**Line No. Two:** 50" cabinets in Golden Oak and Mahogany, ranging in price from \$35.00 to \$37.50.

Will furnish you Cabinets at the lowest cost of production and install your motors and tone arms for you at a very small cost; furnish you motors and tone arms at factory cost. Samples will be sent to well-rated jobbers and assemblers on request.

I have a selling plan which has been tried and is as nearly 100% as we can make it. My selling plan is furnished free to my clients.

**A WORD TO MANUFACTURERS OF CABINETS:** If you are now spending 10% to 25% on your sales, let me do it for you—and I will guarantee to sell your cabinets at 5%, or less. I will carry the accounts; finance the sales and can refer you to the leading bankers and manufacturers as to my financial standing and ability. Address

**NAT KAWIN, The Phonograph Man**  
 316 South Wabash Avenue - Chicago, Ill.  
 Director of Sales, Great Eastern M'frers' Co. and Associate Factories



Model 150

FROM OUR CHICAGO HEADQUARTERS—(Continued from page 141)

**Heads Wholesale Department**

H. C. Barenstecker has been appointed manager of the wholesale talking machine department of the Wade Talking Machine Co. Mr. Barenstecker comes from the Coast, where he has been connected with the Eiler's Music House, of Portland, in capacity of department manager, and also with Sherman, Clay & Co. Since the inception of the Wade Co.'s wholesale business a few months ago it has grown by leaps and bounds, and to-day requires the attention of a manager like Mr. Barenstecker. The company has put out eighteen styles of talking machines in order to accommodate the small dealer who wishes to handle more than one line without too large an investment. In addition to this, the Wade Talking Machine Co. handles all the well advertised lines of accessories, motors, tone arms, and so forth, which can be sold profitably by the retail merchant. One of the newest features added to its line has been a scratch remover, which can be used by dealers most advantageously in doctoring up any little scratches that may appear on their instruments. A refinishing outfit also has been listed in their latest catalog, especially for dealers, who will find it most convenient.

**"Fairy" Lamp Campaign**

The Endless-Graph Mfg. Co., manufacturer of the "Fairy" phonograph lamp, has been carrying on a retail newspaper advertising campaign in behalf of its product during the past month. Its store at 435 South Wabash avenue, established two months ago, has been featured in the ads, which have brought remarkable results. The store has been in the nature of a test to determine the popularity and discover the sales features of the "Fairy" phonograph lamp. In both of these things it has more than come up to the expectations of P. R. Gonsky, president of the concern.

The great difficulty has been the obtaining of enough machines to meet the large retail and wholesale demand which has been made upon

the Endless-Graph Mfg. Co. during the past couple of months. The most important item in this difficulty has been the obtaining of electric motors, with which all the machines are equipped. It is necessary to make up special motors for this lamp and equip them with parts especially designed by the inventor, Mr. Gonsky.

**Opens Offices**

The Venus Co., of Cincinnati, Ohio, has recently opened up offices in Chicago at Room

435, Fine Arts Building. The Venus Co. plans an aggressive campaign in behalf of its product in this territory, and has placed C. E. Ricksecker, vice-president, in charge of the local office. He will be assisted by O. C. Searles, formerly with the Aeolian-Vocalion department of Mandel Bros.

**Chairman of Boosters**

William Wade, of the Wade Talking Machine (Continued on page 145)

**Repair Parts**

For All and Every Motor That Was Ever Manufactured

We can supply any part. The largest and most complete assortment of repair parts—in the United States—on hand, for old, obsolete and present-day motors. If your order cannot be filled from stock, we will make it up special.

Special prices on main springs, governor springs, micras, repair parts, motors, tone arms, steel needles, etc., in quantity lots.

Expert repairing on all makes of phonographs and motors.

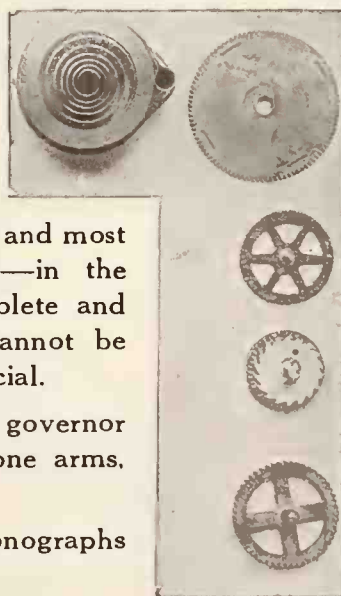
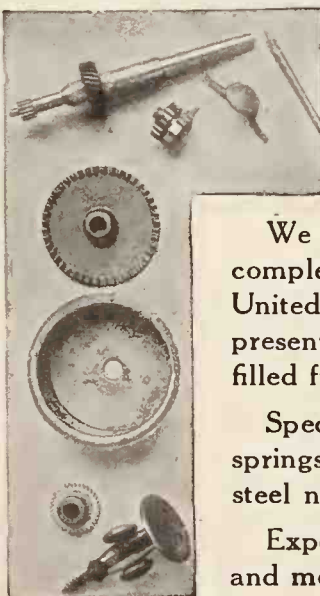

INCORPORATED UNDER THE LAWS OF ILLINOIS

**Consolidated Talking Machine Co.**  
 Manufacturers of

SUCCESSORS TO  
 Standard Talking Machine Co.  
 United Talking Machine Co.  
 Harmony Talking Machine Co.  
 O'Neill-James Co.  
 Aretina Co.

High Grade Talking Machines, Disc Records, Talking Machine Supplies, Etc.

227-229 W. Washington St., Chicago, Ill.

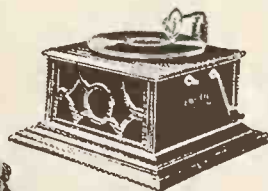

TRADE MARK "CONSOLA"

CABLE ADDRESS "CONSOLA"



# The map shows you why Chicago is the mid-western shipping center for the Aeolian-Vocalion

CHICAGO'S strategic mid-western location; Chicago's remarkable railroad facilities; Chicago's commercial prominence; all fit her pre-eminently to serve Aeolian dealers of the central west.

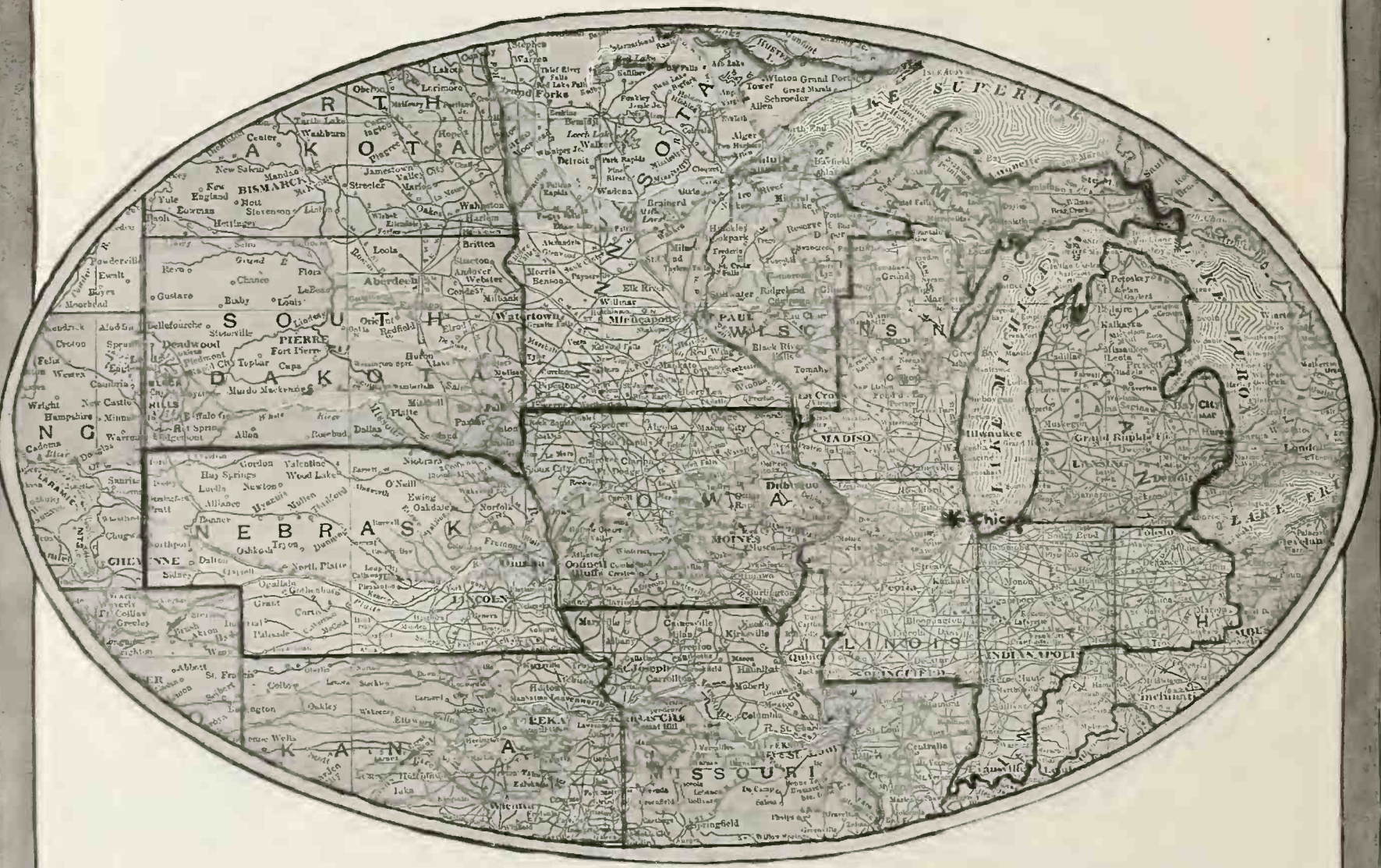

*If you're on the map, write or call on the Aeolian great Mid-Western supply house*

At Chicago is the great depot of the Aeolian Company, where Vocalions in great numbers and in all styles are assembled in readiness to meet the demand of the remarkably extensive, populous and prosperous mid-western district of the United States.

## *Dealers desiring to Secure an Aeolian Vocalion Agency*

are invited to visit Chicago headquarters and to acquaint themselves with the superb equipment and service-capacity of our Chicago shipping station. Arrange for the agency for your city—see and hear the wonderful Aeolian-Vocalion and

the new Vocalion Lateral Cut Record, secure supplies, catalogues, folders, readers, car and window cards and displays, newspaper advertisements, etc. We cooperate liberally with you on the sales of instruments and records. Or write to

## THE AEOLIAN COMPANY

529 South Wabash Ave., Chicago





# THE IRONCLAD

## ENCLOSED MOTOR

IRONCLAD equipment gives your salesmen undisputed talking points and makes the owner a booster for your machine.

Our method of installing springs eliminates all "spring kick"; they release smoothly, delivering an even flow of power, producing a constant speed of turntable.

The springs need no oil or lubrication for life of motor.

The IRONCLAD has so many merits that it can be fully appreciated only by inspection and test. Write or wire for sample to-day.

- B-2—2 spring—4 10" records
- B-3—3 spring—6 10" records
- C-2—2 spring—5 10" records
- C-3—3 spring—8 10" records
- C-4—4 spring—11 10" records
- C-6—6 spring—16 10" records

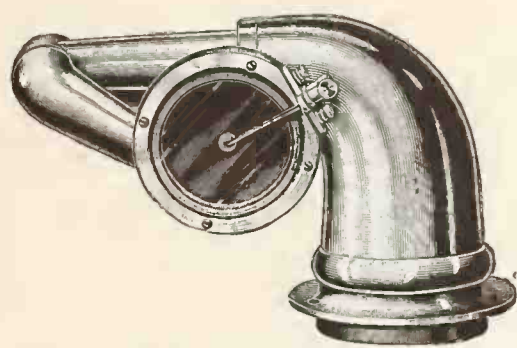

Full throw back tone arm of highest quality. Nickel or Gold Finish

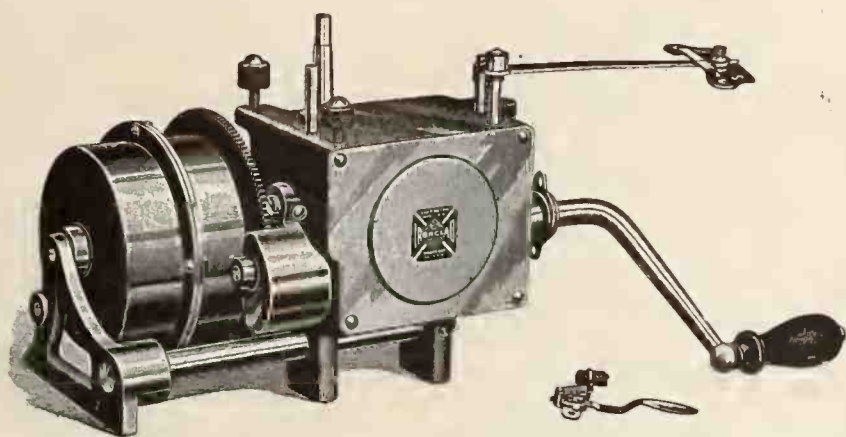

ESTABLISHED 1884

## Cherington Mfg. Co.

Main Office and Factory  
Waukegan - Illinois

Canadian Factory:  
IRONCLAD MOTOR CO.  
718 Drummond Building, Montreal.

OFFICES: NEW YORK, N. Y. 51 East 42d St. CHICAGO, ILL. 108 West Lake St. SAN FRANCISCO, CAL. 320 Market St.

### FROM OUR CHICAGO HEADQUARTERS—(Continued from page 143)

Co., has been asked by the mayor of Chicago to accept the chairmanship of the committee for a drive in the music industries of Chicago to obtain funds for the Boost Chicago Campaign now running. Ten thousand dollars is the mark set for the music industry to subscribe, which will be forthcoming from the piano and talking machine industries' committee. Mr. Wade's associates on the committee are E. H. Uhl, of the Rudolph Wurlitzer Co.; M. J. Kennedy, N. A. Fegen, of Lyon & Healy, and Harold Jarro.

#### Ship by Parcel Post

F. D. Hall, president of the B & H Fibre Mfg. Co., has lately been obliged, in addition to his other troubles, to ship fibre needles by parcel post to certain sections of the country where express and freight tie-ups have stopped delivery.

"Orders for B & H fibre needles have been

coming to us in unprecedented volume," said Mr. Hall. "We have taken increased space and added more machines, and are doing our best to keep abreast of orders. We find the recent freight difficulty very annoying. At one period we were receiving five to eight telegrams a day, urging us to rush special shipments of needles to various parts of the country."

#### Novelty Advertising

A little toy airplane recently patented in Chicago and manufactured for advertising purposes is now being used by certain talking machine companies for advertising their instruments and records. The little airplanes are made of cardboard and sold in small envelopes in knock-down form. They are prized by children everywhere, and even the older people become interested in the principles of air dynamics embodied in the gliding qualities of the little device.

C. J. Van Houten & Zoon, Chicago representatives for the Sonora line of talking machines, are sole selling agents for the airplane advertising novelty and are pushing it as one of the liveliest propositions of the year for the use of talking machine dealers in advertising their merchandise.

#### New Retail "Music Center"

J. K. Morgan has opened a new downtown retail music establishment in the old Siegel & Cooper building at State and Van Buren streets, which goes by the name of "Music Center." It is on the third floor of the building now known as the "Leiter Stores." Mr. Morgan is handling the Brunswick line of talking machines and records, also a complete line of accessories and small musical instruments. This is the only music establishment in the building, outside of the sheet music store and player roll business,

(Continued on page 147)

# The Superior Lid Support

A Spring Balance that Does Not Warp the Lid—  
No Pull on the Lid when Down

A mere touch of the finger lifts or closes the lid,  
which stops at any point desired

Sample—Nickel 75c—Gold \$1.00

Prepaid anywhere upon receipt of price. Submitted on approval, subject to return within a reasonable time, in which event the full price will be refunded  
Quantity Prices Quoted on Application

## Barnhart Brothers & Spindler

Monroe and Throop Streets, Chicago, Illinois

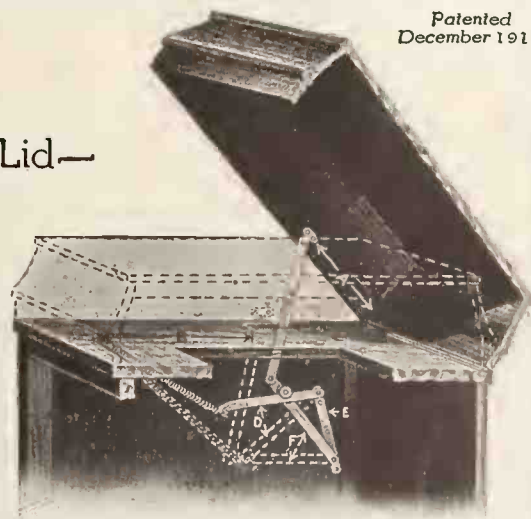

Patented  
December 1919





## New York Telephone Co. Installs Mandels in Rest Rooms

In the telephone exchanges of the States of New York and New Jersey, MANDEL Phonographs are being installed as rapidly as deliveries can be made. The MANDEL was chosen after rigid tests were made, in which some of the best known brands competed. As proof of quality, we can offer no greater testimonial.

The 1920 MANDEL line embodies bigger talking machine values than any other phonograph on the market to-day. The new MANDEL triple spring motor is the last word in phonograph motors. Runs and winds noiselessly. The new MANDEL patented reproducer plays records with a tone volume that is unexcelled.

Low retail selling prices, liberal discounts and terms to dealers, and guarantee of satisfaction to every ultimate purchaser, are three reasons why you should investigate our proposition without delay.

The new art portfolio illustrating the complete MANDEL line for 1920 is now ready for distribution. Write for your copy to-day. With it we will include our confidential proposition to dealers.

More than 3,500 dealers are now selling MANDEL Phonographs. Your territory may be available.

### MANDEL MANUFACTURING CO., Inc.

General Offices, 501-511 So. Laffin Street  
CHICAGO, ILLINOIS

F. S. HARMON & CO., Northwestern Distributors, Tacoma, Seattle, Spokane, Portland.  
HARLE-HAAS CO., Nebraska Distributors, address Council Bluffs, Iowa  
WICHITA WHOLESALE FURNITURE CO., Kansas Distributors, address Wichita, Kansas  
HARDING KIRK CO., Distributors of Utah and Eastern Idaho, Salt Lake City, Utah  
NEW ORLEANS CHAIR CO., New Orleans, La.

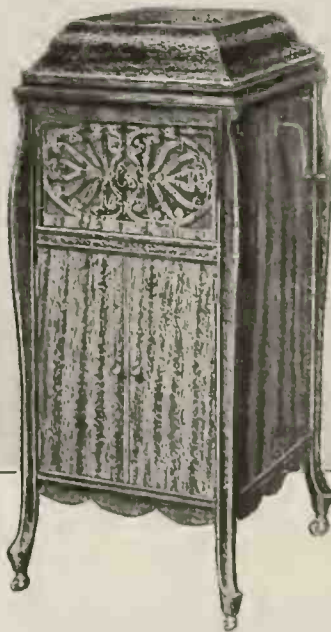
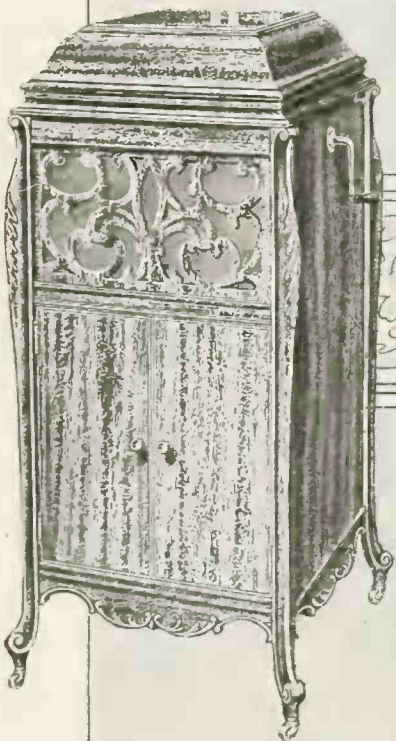



# Three World Beaters—Each a Wonderful Seller



Model 6

45½ in. high, 18 in. wide, 21 in. deep. Can be had in genuine mahogany and golden oak; equipped with double spring Cast Iron Motor and Universal Tone Arm.

Made in our own factory from Lumber to a Complete Machine.

Nothing has been left undone in the perfecting of these three very artistic models.

If you are a Live Wire Dealer, write us today, *don't put it off.*

PRICES ON REQUEST

**THE MELOTONE IS ALL ITS NAME IMPLIES**



Model 7

48 in. high, 20 in. wide, 23 in. deep. Genuine mahogany or golden oak; has the highest type double spring cast iron frame motor; guaranteed tone quality.

Distributors looking for a Phonograph with merit will find it of vital interest to get in touch with this line.

Our Factory with a capacity of 50,000 Machines yearly means much to you. Why not tie up with a concern such as we are?

**THE MELOTONE IS IN A CLASS BY ITSELF**



Model 8

51 in. high, 22 in. wide, 24 in. deep. The most wonderful conception of phonograph construction, genuine piano finish; has the very highest type 3-spring motor.

### A Few Items to Interest You

Records, Needle Cutters, Fibre Needles, Record Brushes, Steel Needles, Tonofone Needles, Albums, Store Fixtures.

### Have You Our Catalog?

Let us have your name at once, so that we can mail you our latest catalog, now on the press.

**Superior Phonograph Co.**

**320 SOUTH WABASH AVENUE CHICAGO, ILLINOIS**

FROM OUR CHICAGO HEADQUARTERS—(Continued from page 145)

known as Betty's Song Shop. The entire building contains retail stores of every kind, and while each will be run separately, the various stores will be much in the nature of the department store business. Mr. Morgan himself has an extensive acquaintance and wide knowledge of the music trade, having traveled for the Rudolph Wurlitzer Co. during a period of ten years.

#### Announce New Universal Motor

The Universal Stamping & Mfg. Co., of this city, have just announced that next month they will put on the market a new Universal motor. This motor has just been patented and bears all the earmarks of perfection. It contains one one-inch spring forty feet in length, light gears, three of which are of Bakelite and one worm. The governor is of a vertical type and is enclosed in a Bakelite casing, which prevents the governor balls from spreading beyond a certain distance. None of the shafting contained within the motor is over 1½ inches long. The casing of the motor proper, which is semi-enclosed, is approximately of the size and shape of an ordinary alarm clock. It is attached to the motor board by four screws. The turntable shaft has its bearing on the top of the spring-shaft. The manufacturers claim that

with one winding it will run continuously for from twenty-five to thirty minutes, which is equivalent to eight ten-inch records.

Sales Manager W. M. Shipley has been calling on the Western manufacturers with this little motor for the past few weeks, and he states that everywhere he went he received much encouragement.

#### A. B. O'Connor Makes Change

A. B. O'Connor, formerly in charge of sales of Central States for Charles H. Elting & Co., announces that he has become connected with the Firestone Phonograph Co., of this city.

#### Gets Legion Post

Harry L. Flentye, in charge of the talking machine department of the Commonwealth Edison Co.'s store on North Broadway, has been elected adjutant of the Wilmette post of the American Legion. Mr. Flentye has been connected with the talking machine trade in Chicago for some time and has made many friends who will hear of his activities in the American Legion with pleasure.

#### Wind Breaks Cable Company Windows

Two large windows of the Cable Company, facing on Wabash avenue, were broken by the big windstorm which hit the city Sunday, (Continued on page 149)

Magnifies Sound 50 Times  
**ACME SOUND AMPLIFIER**

Enables the repairman to locate the precise point of origin of unnecessary noise in the motor without loss of time or useless disorganization of the mechanism which results from guessing or the sense of hearing alone.  
**MAKES EVERY MOVING PART IMMEDIATELY ACCESSIBLE**

**"Guesswork Won't Do"**

The ACME allows a test with the drag of the needle throughout the length of the record.

A  
C  
M  
E

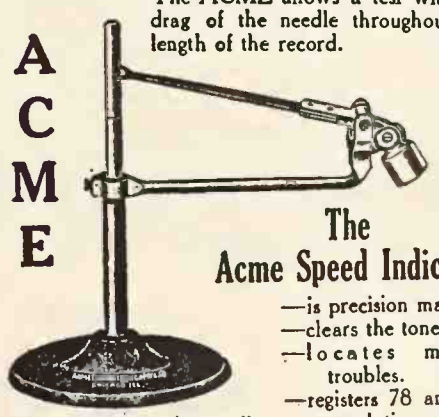

**The  
Acme Speed Indicator**

- is precision made.
- clears the tone arm.
- locates motor troubles.
- registers 78 and 80 revolutions.

"The repairman's stethoscope."  
Made by  
**Acme Engineering & Mfg. Co.**  
1622 Fulton Street CHICAGO

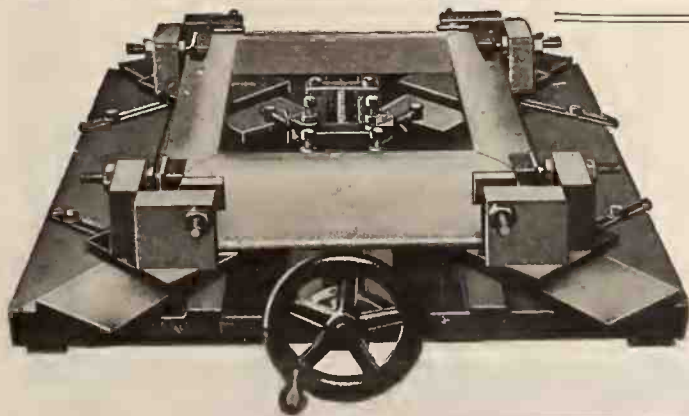

WE ILLUSTRATE THE  
**"Handy" Dome Clamp**

Quick action for clamping domes and frames on Talking Machine Cabinets  
Write for Catalogue of clamping machines for Cases and for all purposes.  
**VENEER PRESSES AND CLAMPS**  
**HANDY MFG. CO.**  
27 E. Madison St., Chicago, Ill.

## AMBEROLA SERVICE



As the Edison Cylinder products are not controlled by zone system, dealers anywhere can take advantage of **LYONS' SERVICE**, which is efficient, skilled, and up-to-date.

The Amberola is absolutely the best value offered the public today.

**J. I. LYONS**  
17 WEST LAKE STREET CHICAGO



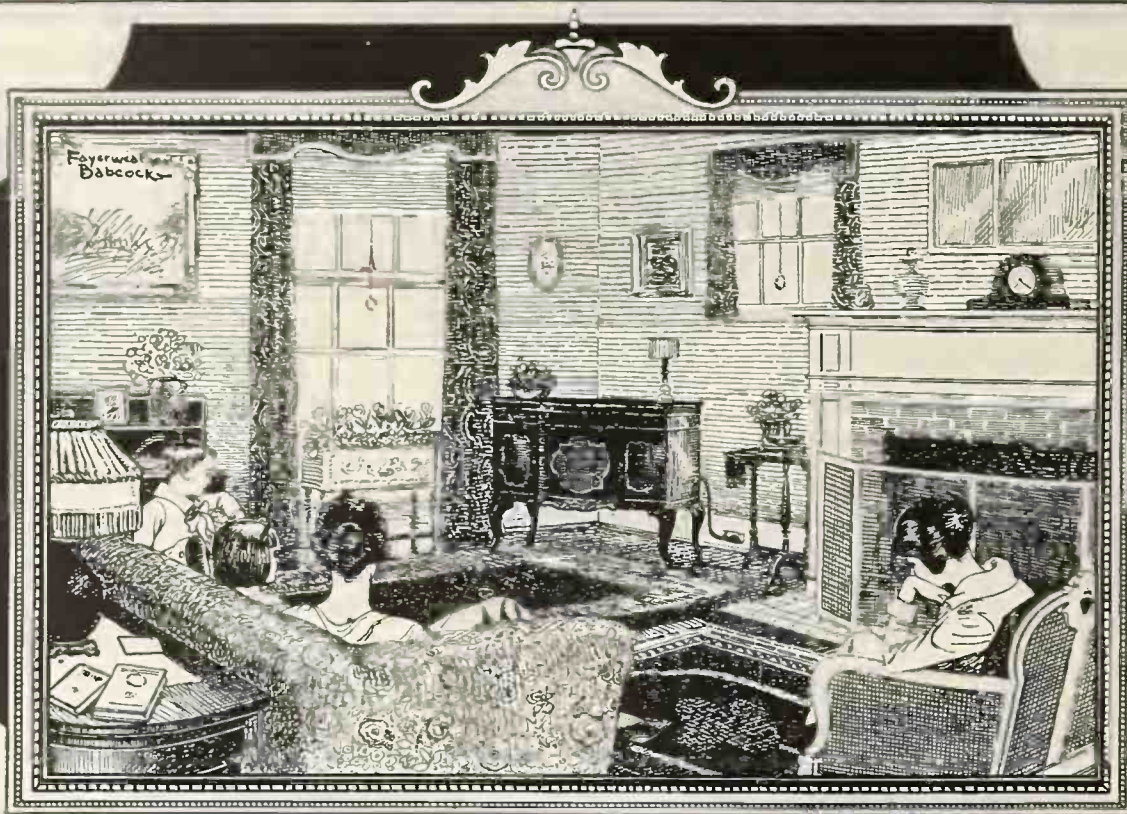

## MOELLER-WATERS, INC.

*offer*

### The Roberts Electric Phonograph Motor

which for three and one-half years has proved itself the *best* electric phonograph motor on the market

#### BECAUSE

1. Its durability and efficiency have been demonstrated.
2. It is positively noiseless.
- \*3. The installation is easy and simple.
4. It will fit any make of cabinet—nearly always without change.
5. It can be used on either direct or alternating current.
6. It will neither get hot nor burn out.
7. It runs at constant speed under all conditions.
8. It requires no attention for years—not even oiling.
9. It eliminates cranking the phonograph.
10. It is reasonable in price.
11. You can be assured of prompt delivery.
12. It is **GUARANTEED ABSOLUTELY** by its makers, who are today the largest manufacturers of electric phonograph motors.

Manufacturers of phonographs who appreciate the steadily increasing demand for electrically-driven machines can protect their own reputation by installing

*Roberts*  
ELECTRIC  
PHONOGRAPH  
MOTOR

Its Reliability and Dependability made it famous.  
(Made in gold and nickel finish)

We are accepting contracts for delivery up to January 1st, 1921.

Write or wire us for quotations or sample motor.

## MOELLER-WATERS, INC.

*Sole-Selling Agents*

LYON & HEALY BLDG.

::

::

::

CHICAGO

\*Dealers: Our replacement proposition is worth investigating. Write us for full information.



YES, THIS IS

# The Oro-Tone

QUALITY FIRST

THE PERFECT EDISON ATTACHMENT  
WE CAN PROVE IT—IF YOU WILL SAY—  
“Send sample on approval” or ask your jobber

Retail Price, Nickel Plated, \$8.50 Highest Grade Gold Plating \$12.50

The New ORO-TONE Safety Point Steel Needle Now Ready  
Sample Thousand 60 Cents

Mfrs. of highest grade tone arms, reproducers, attachments for phonographs for playing all records. Diamond and jewel point needles, motors, supplies, etc.

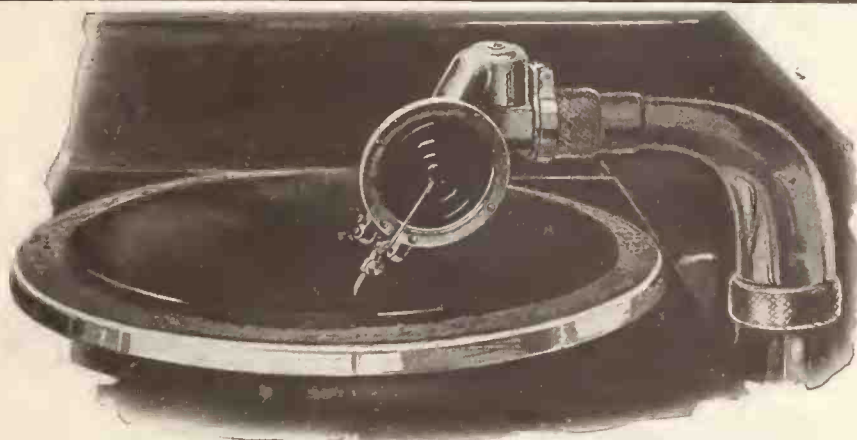

ILLUSTRATION SHOWS THE ORO-TONE ATTACHED

## The Oro-Tone Co.

QUALITY FIRST

Successors to COMBINATION ATTACHMENT CO.

1808-10 IRVING PARK BOULEVARD, CHICAGO, ILL.

### FROM OUR CHICAGO HEADQUARTERS—(Continued from page 147)

March 28. No one was inside at the time and consequently no one was hurt, but the salesmen's desks were showered with pieces of broken glass.

#### Makes Exhibit of Steger Phonographs

At the recent convention of the Retail Hardware Men's Association, held in Des Moines,

hibit had been originally planned by Warfield-Pratt-Howell, but the demand for floor space at the exposition was so heavy that only a limited section could be secured. However, the large attendance, coupled with the enthusiasm of visiting buyers, more than compensated for the lack of proper display rooms. From the

#### Dealer Helps

Cole & Dunas Music Co., of this city, has just received from its printers one of the most cleverly designed catalogs that has been seen in this section for some time. Among the many new features is their Queen Anne design console type talking machine. This instrument is made in very fine finish and comes in all woods. The tone arm and turn table, while the left half of the cover lifts up so as to give access to the tone arm and turn table, while the right half of the cover is stationary. It is equipped with the well-known Blood tone arm and “mute” attached reproducer.

The catalog is also chock full of “dealer helps” and want ad cuts, gotten up for the purpose of helping dealers in their local advertising. It is a helpful publication.

#### Gives Tone Test

The Irving Park branch of the house of James I. Lyons, Amberola jobbers of Chicago, gave a tone test at the Irving Theatre recently. Mr. Hardy Williamson, tenor, a “re-creation” artist, sang “Holy City” and “Thora.” The test proved successful in every way. Mr. Lyons, when talking to a World representative recently, said it was comical to watch the facial expressions of the out-of-town dealers who visit him, when they see the amount of cylinder business he is carrying on at his store. It seems that nearly all the dealers are under the impression that the cylinder machines are antiquated, and that the only record business going on is for disc records. “In reality I am of the opinion that the

(Continued on page 151)

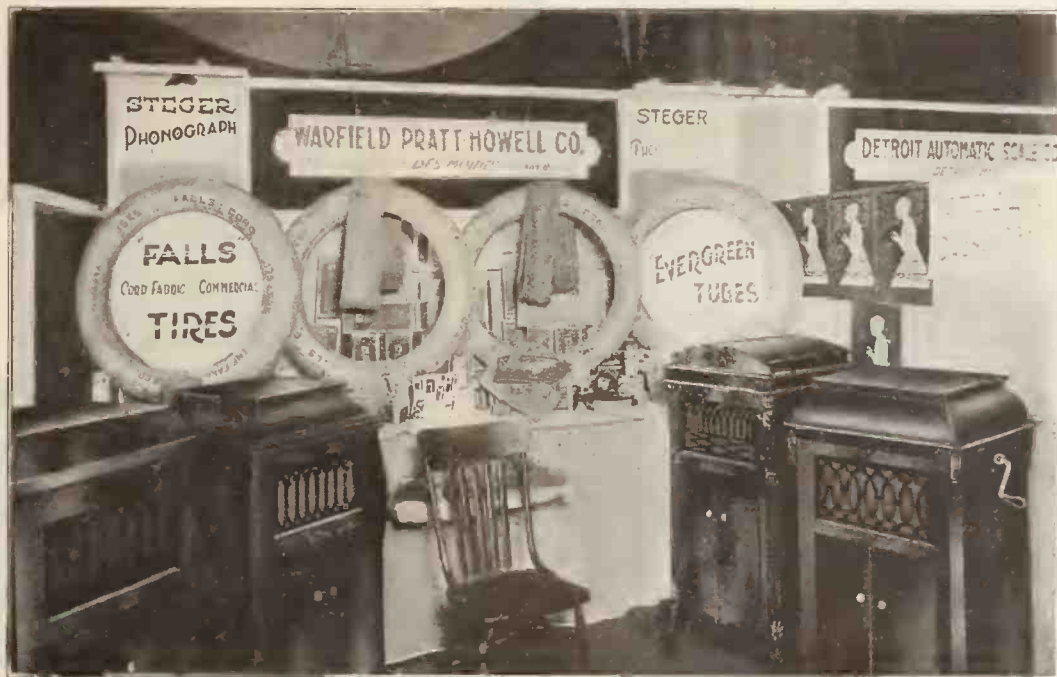

Interesting Steger Display Made by Warfield-Pratt-Howell Co.

Ia., the Warfield-Pratt-Howell Co., Iowa distributor for the Steger phonograph, exhibited a whole line of Steger phonographs. A large ex-

hibit had been originally planned by Warfield-Pratt-Howell, but the demand for floor space at the exposition was so heavy that only a limited section could be secured. However, the large attendance, coupled with the enthusiasm of visiting buyers, more than compensated for the lack of proper display rooms. From the time the convention doors opened, each morning until closing time, the Steger phonograph booth was a big center of attraction.

# MELODIA Phonograph Company

The  
**MELODIA**  
furnished in five  
styles and sizes rang-  
ing in price from  
**\$75.00 to \$325.00**  
WRITE FOR  
ATTRACTIVE DEALERS'  
OFFER

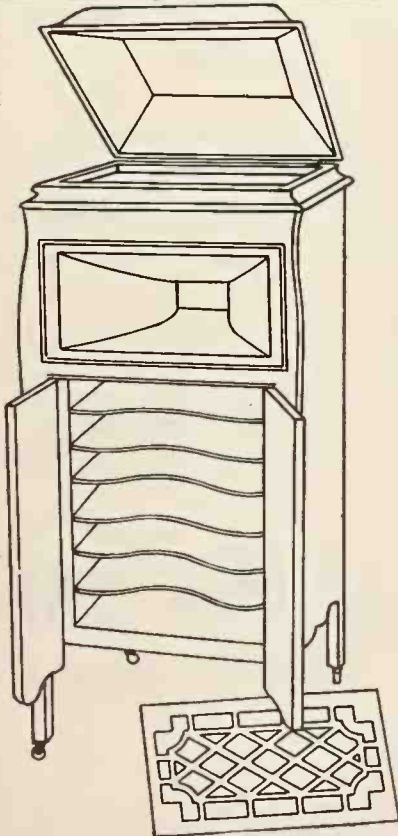

## 400 N Sangamon St. Chicago Ill.

The Melodia will now have the stage, appearing in outline, all built of heavy five-ply stock. Furnished in standard finishes. The Melodia is unsurpassed in tone on account of its “Patent Applied For” tone chamber and its equipment of the best motor and tone arm. Played and indorsed by “Marinuzzi,” director of Chicago Grand Opera Co. Live dealers wanted.  
**The Melodia Phonograph Co.**  
400 N. Sangamon Street  
CHICAGO, ILL.  
PHONE, HAYMARKET 3833



NEW      PROFITABLE      STURDY      ARTISTIC      LIGHT      RIGHT

# SOMETHING ABSOLUTELY NEW IN PHONOGRAPHS

- New Design
- New Finishes
- New Size
- New Construction
- New Price
- New Market
- New Profits



RETAIL PRICE

# \$50

\*\*\*

WHOLESALE PRICE

Satisfactory to  
Retailers

## The "VIT"

**Motor**, tone-arm and reproducer of standard make, fully guaranteed. Plays all records.

**Finishes**, Ivory Satin Enamel, panels decorated with colonial figures in dainty coloring.

French Blue Enamel, panels decorated with richly colored designs.

Oriental Black, panels decorated with Japanese designs in colors.

Mahogany Finish, without panel decorations.

**Design**, Sheraton Period, 32 inches high, 15 inches square. The ideal instrument for the greatest number of different uses, for sun porches, summer and winter cottages, small apartments, rooms, nursery. Easily carried from room to room, up and down stairs, and meets with many other purposes that other types do not.

**Window Display**, these four richly finished floor cabinet machines make such an attractive show that compels attention and sales to be had in no other manner.

**Exclusive Sales Agency** for live dealers. Quick deliveries. Be the first and only dealer in your town to offer the public something new.



Sectional Record Cabinets for stores.  
Capacity for over 200 10 and 12 inch records per section. Dimensions of cabinet 12 inch high, 36 inch long and 12 inch deep. Price per section, \$10.00

## VIT TALKING MACHINE COMPANY

123 West Madison St., Suite 412

CHICAGO . . . . . ILL.



???

**WHY  
Mr. Dealer**

Are Your Competitors Selling So Many

**Phono-Grands**

???

Simply Because They Know That



**PHONO-GRAND**

Fills a Long Felt Want

This little compact combination of a splendid Phonograph and an electrically controlled Reproducing Piano is just the thing for ice cream parlors, restaurants, cafes, etc. It fits in nicely and takes up no more room than an ordinary talking machine.

Want particulars? Write today

**J. P. Seeburg Piano Co.**  
419 W. Erie St. Chicago, Ill.

**FROM OUR CHICAGO HEADQUARTERS**

(Continued from page 149)

demand for cylinder records is greater than it ever has been, and I know for a certainty that each month the quantity of cylinder records I am disposing of increases."

**Six Best Sellers**

The six best Victor sellers for the month are: "Mystery"; "Oh"; "You'd Be Surprised" and "Keep Moving"; "I Might Be Your Once in a While" and "You Are Free"; "Was There Ever a Pal Like You" and "You're a Million Miles From Nowhere"; "Now I Know" and "I'll Always Be Waiting for You"; "That Tumble-Down Shack in Athlone."

The six best Columbia sellers for the month are: "Venetian Moon" and "Bo-La-Bo"; "Just Like a Gypsy" and "In Your Arms"; "Elder Eatmore's Sermon on Generosity" and "Elder Eatmore's Sermon on Throwing Stones"; "Chloe" and "Was There Ever a Pal Like You"; "You're a Million Miles From Nowhere" and "Once Upon a Time"; "Just Like the Rose" and "When You're Alone."

The six best Edison sellers for the month are: "Phedre Overture, Parts 1 and 2"; "In Siam" and "Tents of Arabs"; "Peter Gink" and "Yelping Hound Blues"; "Carnival of Venice" and "Silver Threads Among the Gold"; "Second Hungarian Rhapsodie, Parts 1 and 2" and "Second Hungarian Rhapsodie, Parts 3 and 4."

The six best Brunswick sellers are: "Dardanella" and "Fast Asleep in Poppy Land"; "Echoes" and "Just Like the Rose"; "Nobody Knows" and "Come to the Moon"; "Patches" and "Swanee"; "I Want a Daddy" and "Some Day Down in Carolin"; "Tulip Time" and "I Might Be Your Once in a While."

The six best Okeli sellers are: "Freckles" and "Please"; "Mystery" and "Meet Me in Bubbleland"; "Tents of Arabs" and "Nobody Ever"; "Swanee" and "Blues My Naughty Sweetie Gives to Me"; "Just for Me and Mary" and "Lullaby Blues"; "For Every Door That Closes" and "I'll Love You Just the Same."

The six best Empire sellers are: "Wonderful Pal" and "Just for Me and Mary"; "I Might Be Your Once in a While" and "A Pretty Girl Is Like a Melody"; "Dardanella" and "I Never Knew"; "Hand in Hand Again" and "We Must Have a Song to Remember"; "Dardanella" and "You'd Be Surprised"; "My Isle of Golden Dreams" and "See Saw."

The six best Emerson sellers are: "I Might Be Your Once in a While" and "I'm Always Building Castles in the Air"; "Pretty Little Rainbow" and "Mavis"; "The Last Rose of Summer" and "You Ain't Heard Nothin' Yet"; "Venetian Moon" and "Rose of the Orient"; "Bo-La-Bo" and "Sweet and Low"; "Oh" and "That Wonderful Kid From Madrid."

**Have You Citronella?**

Dardanella has been one of the most popular records of recent years. Witness the choleric temper of the talking machine record salesman when they are asked to ship quantities of this number. Apropos of this little matter, a woman was recently in a Wabash avenue music store and asked the following question:

"Have you Citronella?"

A look of blank amazement replaced the smile on the clerk's face.

"I am afraid you will have to go to a drugstore for that, madam," he stammered.

"Why a drugstore?" she said coldly.

"Because Citronella is a remedy for mosquito bites, madam."

"The very idea," she exclaimed. "Haven't you heard of the latest fox-trot?"

"Oh, you mean Dardanella, don't you?"

And she did.

**"Stubborn Facts About Prices"**

The Baldwin Piano Co. has prepared a little descriptive folder on comparative prices of materials in 1914, 1917 and 1920. It is entitled "Stubborn Facts About Prices," and illustrates the different prices in different years by means of long and short lines. For instance, lumber

(Continued on page 153)

**Announcing the**

New 1920

**Playerphone**

MANUFACTURED BY

**PLAYERPHONE TALKING MACHINE CO.**  
D.W. MCKENZIE, CHICAGO, ILL. W.D. CALDWELL, TREASURER

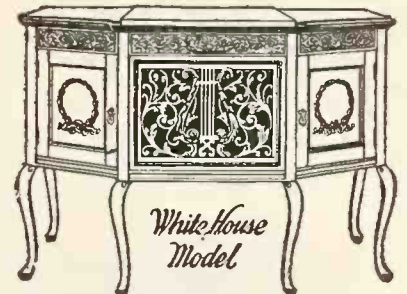
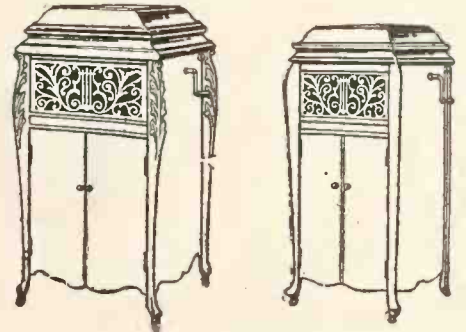

**To Playerphone's Dealers and Friends!**

Watch our big national advertising campaign beginning in the Saturday Evening Post April 24th

Other national magazines, to be announced later, will be included in our campaign for your benefit from May, 1920, onwards.

For tone, quality and beauty, Playerphone stands in a class by itself. Eleven models of original and beautiful design. Plays all makes of records perfectly.

Merchants who are looking for a thoroughly high-grade phonograph with original and exclusive features at the right price will do well to communicate with us directly or with any of our jobbers.

- Chapman Drug Company, Knoxville, Tenn.
- Clawson & Wilson, Buffalo, N. Y.
- The Day Drug Co., Akron, Ohio.
- The Des Moines Drug Company, Des Moines, Iowa.
- B. Deuter Furniture Company, Beaumont, Texas, and Houston, Texas.
- L. S. DuBois Son & Company, Paducah, Ky.
- W. J. Gilmore Drug Company, Pittsburgh, Pa.
- Healy Brothers, 13th & Hoyt St., Portland, Ore.
- Hornick, More & Porterfield, Sioux City, Iowa.
- Kauffman-Lattimer Co., Columbus, Ohio.
- Reid Lawson, Inc., Birmingham, Ala.
- Chas. Leich & Co., Evansville, Ind.
- The Murray Drug Company, Columbia, S. C.
- Oklahoma Book Company, Oklahoma City, Okla.
- Orchard & Wilhelm Company, Omaha, Neb.
- Twin City Talking Machine Co., Urhriehsville, Ohio.
- F. M. Umphred & Son, Oakland, California.
- Van Vleet-Mansfield Drug Co., Van Vleet, O.
- Western Jobbing & Trading Co., 724 S. Broadway, Los Angeles, Cal.
- H. W. Williams & Co., Fort Worth, Texas.
- Don's Music Store, Hastings, New Zealand.

The PLAYERPHONE comes in nine different styles and sizes, ranging from \$110 to \$500. Each PLAYERPHONE guaranteed to give entire satisfaction. Is now being advertised monthly in this and several other leading publications.

**SOME DESIRABLE JOBBING TERRITORY STILL OPEN**

For Further Information Address

**PLAYERPHONE TALKING MACHINE COMPANY**

4223-41 W. Lake St., Chicago

D. W. MCKENZIE, Pres. W. D. CALDWELL, Treas.



*Mechanically Perfect*

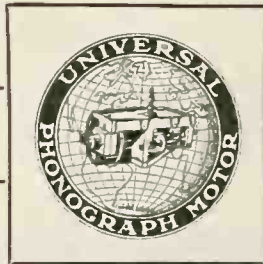

*Noiselessly Operated*

# UNIVERSAL

**The Motor that Compels the Phonograph to Perform Perfectly**

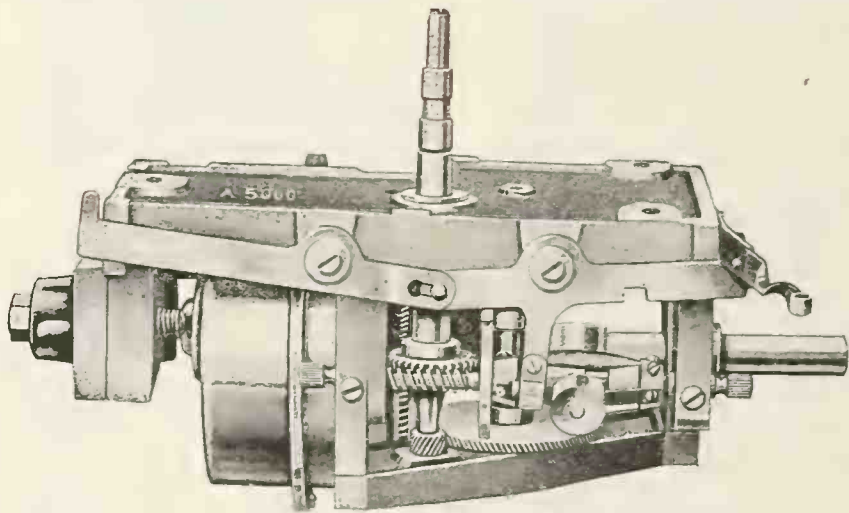

Universal Motor "A-5"

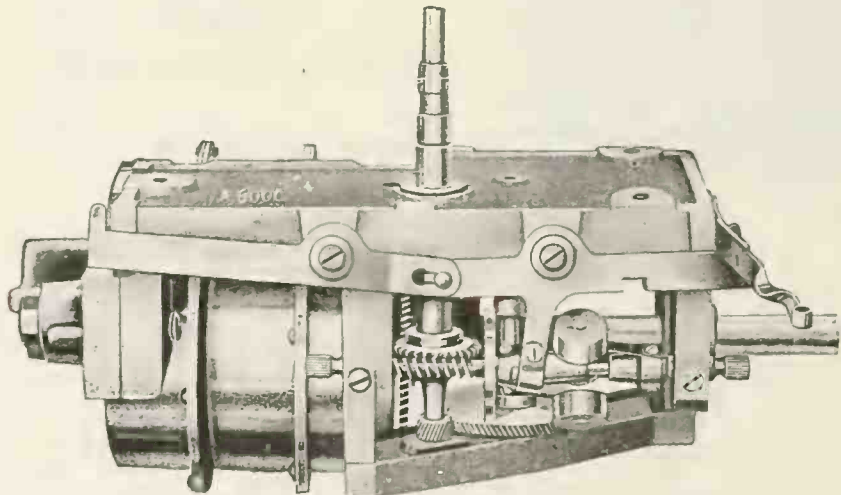

Universal Motor "A-6"

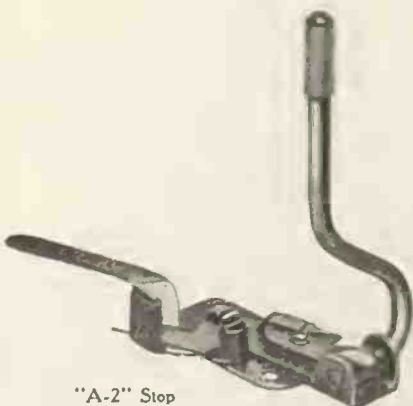

"A-2" Stop

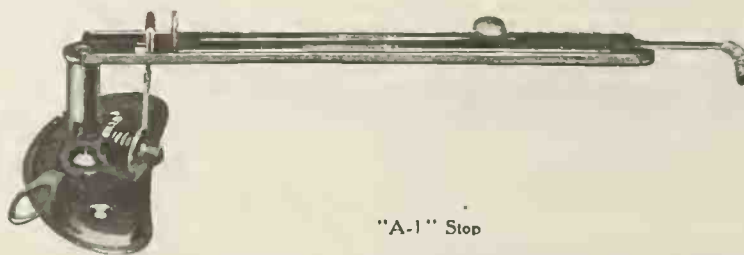

"A-1" Stop

*Simplest and most efficient stops. Easily installed and are guaranteed. Send 75c in stamps or money order for sample.*

## Universal Stamping and Manufacturing Co.

Main Offices and Factory

1917 to 1925 So. Western Avenue Chicago, Ill.

*NOTE: The Universal Stamping and Manufacturing Co. has established an EASTERN DIVISION AT WILLIAMSPORT, PA.*



FROM OUR CHICAGO HEADQUARTERS—(Continued from page 151)

selling at 100 in 1914 is given at 115 in 1917 and 3673 in 1920. In regard to the purchase of raw materials it has the following to say: First, orders for materials to be delivered during the year 1920 can only be placed on the basis of prices prevailing at the date of shipment. Second, prices quoted in response to inquiries are given only with the understanding that they must be accepted immediately. Third, acceptances of prices quoted and subsequent placing of orders do not guarantee deliveries.

**Sonora Advertising in the West**

A large number of billboards have been contracted for and erected by C. J. Van Houten & Zoon in behalf of Sonora phonographs, which are handled by this concern in Illinois and Wisconsin. The largest billboard advertisement in the city of Chicago appears on a skyscraper at Sixth street, between Wabash avenue and the "L" tracks. An immense replica of the Sonora instrument greets passersby in street ears below on Wabash and the elevated trains on the other side.

Another very large electrically illuminated sign was erected during the latter part of the

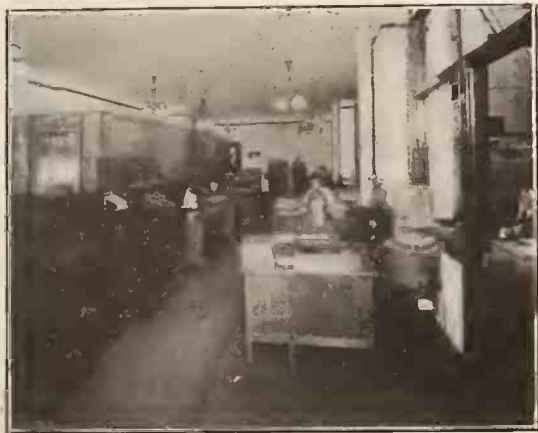

Office of Van Houten & Zoon

month on State and Madison streets in the loop, directly opposite Carson, Pirie, Scott & Co.'s big department store. This large electric sign at 20 S. State carries its message to Loop workers and visitors at night. A big mahogany machine stands out prominently on a blue background, the word Sonora being printed in white letters. There are the two largest Sonora billboard advertisements in the city and are remembered by everyone who has seen them.

In addition to the two above mentioned signs, C. J. Van Houten & Zoon have erected other smaller billboards throughout the city of Chi-

cago, and particularly along the boulevard systems. On the South Side alone they have twenty-five boards, and one in particular on the



Van Houten & Zoon's Sonora Demonstration North Side, which has brought excellent results. This is at Lincoln and Robey.

"We have found billboard advertising one of

the very best mediums," said L. Golder, of the Chicago office. "The success of Sonora billboard advertising in New York has convinced us of its effectiveness in Chicago. More people are reached effectively day after day by this sort of advertising than in any other way. Found the message of Sonora day after day into the class of people that are buyers."

The Sonora offices in Chicago were recently moved to the seventh floor of the Marquette building, at Dearborn and Adams streets, and a spacious room taken in the same building on another floor, room number 1737, which is being used solely for Sonora dealer demonstration purposes. A cut of the picture appears herewith, showing a number of Sonora models grouped within the room, and also a photograph of their main offices in 732 Marquette Building.

C. J. Van Houten & Zoon are now handling numerous accessory lines in their talking machine business, Republic player rolls and Okeh records being the chief of these.

**GREATLY INTERESTED IN CHICAGO SALES CONFERENCES**

Frank Discussion and Interchange of Selling Ideas and Information Prove of Genuine Value to the Progressive Salesmen Who Are Attending the Meetings Now Being Held

CHICAGO, ILL., April 6.—The first of a series of weekly sales conferences was started on Friday evening, March 12, in Room 1140, Continental & Commercial Bank Building, for men interested in the selling end of the music industry. Scattered among the many piano men were also a few talking machine salesmen, who gained important ideas from the discussion. So attractive, indeed, did the idea of the sales conferences look to those present, after two hours of rapid-fire discussion, that by unanimous decision it was decided to hold the gatherings every week and push the hour ahead from the time originally set from 7:30 to 7 o'clock. Frank E. Morton, of the American Steel & Wire Co., announced that Room 1140 would be available for this purpose, and invited the music men of the city to be present whenever possible. One of the most important points brought up at the meetings was the necessity for salesmen knowing more about the product they sell, although it was pointed out that some of the most successful salesmen knew less about the technical points of their instruments. This was attributed to qualities of inherent salesmanship. One of the chief topics of the first nights was the proper manner of receiving a customer who has entered

a retail store. Whether or not a regular salesman should be the first to greet the customer, whether the salesmen should receive customers in turn, or whether the first overtures should be made by an information clerk, who turns the customer over to a salesman—all these points were brought up and discussed at length, it being the consensus of opinion at the end of the discussion that the information clerk method is best.

Perhaps the most remarkable thing about this first meeting was the enthusiasm shown by those present and its effect. The spirit of cooperative discussion brought forth by the meeting imbued the participants with that particular brand of business acumen best expressed by the word "pep," whether or not they finally carried any definite ideas for improving their sales arguments.

Frank E. Morton opened the meeting with a short address, in which he stated the purposes of the gatherings, and appealed for an unprejudiced discussion of sales methods. "The great function of the progressive salesman of to-day and to-morrow," said he, "is not simply to sell his instruments; but to justify his sales in the

(Continued on page 155)

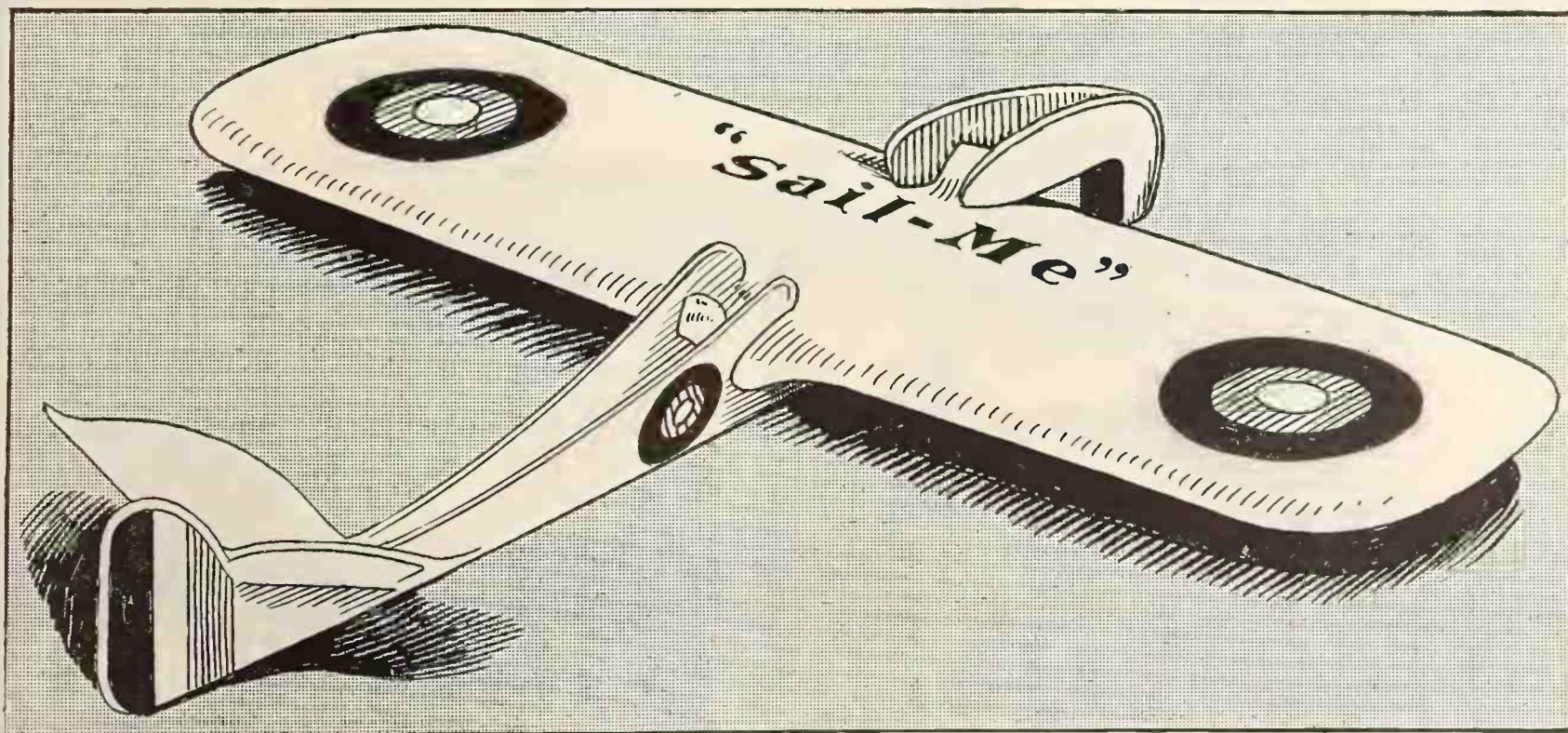

Flies as gracefully as a bird and does the stunts of an expert aviator. "Sail-Me" airplanes are the biggest little things of the year in the advertising

novelty field. Mails flat in an envelope—easily and quickly assembled. Send 15c for sample—quantity prices very low.

Your advertisement printed on the wings of the plane makes a very unique, attractive and effective advertising novelty.

New York  
105-109 Hudson Street

**C. J. VAN HOUTEN & ZOON, Distributors**

Chicago  
140 Dearborn Street South





## Phonograph Headquarters

## May Bulletin

# FREE

Every live, wide-awake Phonograph Dealer should have this *May Bulletin* from Phonograph Headquarters. *Write to-day.* From cover to cover, it is filled with hundreds of items you need—bristling with *up-to-the-minute sales ideas* and a world of dealer helps.

### Our Line

Albums	Gennett Records	String Instruments
Automatic Stops	Genuine Diamond Points	Sapphire Needles
Bell-Hood Needles	Main Springs	Ten-M Needles
Cabinet Hardware	Motors	Tone-Arms
Columbia Records	Moving Covers	Tonofone Needles
Demonstrating Booths	Mysto Needles	U. S. Player Rolls
Delivery Envelopes	Olympian Phonographs	Universal Fixtures
Efficiency Counters	Okeh Records	Victor Records
Fibre Needles	Record Lites	Violins and Bows
Fibre Needle Cutters	Record Racks	Wall-Kane Needles
	Repeatographs	

### Everything in Phonographs and Supplies

It meets that long felt want for a source of Phonographs and Supplies—always on hand for immediate delivery—at prices that set a standard of value by which all others are gauged. Send for this *Free Bulletin* now.

### 48 Hour Delivery

We aim to ship all orders in 48 hours. That schedule of quick shipment means smaller stocks for you—smaller investment and quicker turnover. Don't miss at least seeing this *Bulletin*.

### Write for *Bulletin*—TODAY!

Send a postal or a letter and get this *May Bulletin* even if only to compare values. (We will also send you our future *Bulletins* regularly.) No matter what your needs, we have it—for less—so write to-day—this minute, or you may forget.

# COLE & DUNAS MUSIC CO.

Phonograph Headquarters 50 WEST LAKE ST. CHICAGO.



FROM OUR CHICAGO HEADQUARTERS—(Continued from page 153)

minds of his customers." He pointed out that all persons in the United States who have a home are chronic purchasers of some sort of musical instrument. They may not know it, but they are potential purchasers nevertheless, and it is by the educational work by the trade and particularly by the salesmen in their selling arguments that these people are to be reached. It was said that if salesmen and merchants attending the conferences are to remain content with the class of trade which now walks into their stores, there is no need for such sales conferences; but if they desire to enlarge their scope and sell to persons of a class with which they are not doing business to-day, the conferences will be of undoubted benefit to the trade.

The second weekly discussion held on Friday, March 19, took as a topic for the evening, "The One Price System." This was of absorbing interest, and held the assembled salesmen until a late hour. The consensus of opinion at the close of the discussion was to the effect that the one-price system is supremely to be desired, but that difficulties in the way of its establishment are great; that although the salesmen now working under the multi-priced system would almost invariably oppose any change to the one-price system, the sales managers and proprietors of retail business are principally responsible for the present deplorable and far too widely spread confusion in price policies. In these sales managers and proprietors is vested power to declare in favor of the one-price system, and to force salesmen to adhere to it; furthermore, that salesmen now working under the multi-priced method can be shown where the one-price system will ease their working conditions as it has in other trades, and also put more money in their pockets. At the end of the discussion, a poll was taken of those favoring and those opposing the one-price system. There was what amounted to a unanimous decision in the affirmative. One man cast a vote in opposition, as applying the system to his own business, although he expressed himself in favor of the system generally. This gentleman held that the business of a small store outside the centrally located business district of a large city needs the multi-priced system in order to successfully combat the larger and more centrally located institution.

Another interesting topic dealt with the relative duties of city salesmen and floor salesmen. The discussion on the former was on the proper method of gaining and holding an entree into the home, the advisability of an automobile in getting a prospective customer down to the store, and the psychological effect on such a customer of an automobile in possession of the

salesman. It was generally admitted that the most and best sales come through contact with satisfied, previously sold customers. "Contact" is defined as the merchant's interest in past customers taken in the form of calls from time to time to see if the instrument is giving the proper service. The fact that a large amount of business is accomplished during evenings, led to a discussion as to keeping retail stores open after daylight. It was decided that this is advisable only in certain localities and with certain classes of people; that it could damage prestige in higher class sections. Also the desirability of music establishments maintaining smaller branches for the convenience of customers was taken up. Most of the salesmen present expressed themselves in favor of bringing the customer to the home base, where more impressive surroundings helped to make the sale sure.

**NEW BRUNSWICK CAMPAIGN READY**

Elaborate Plans for National Advertising to Reach Twenty-four Million Readers Monthly

CHICAGO, ILL., April 3.—Plans for advertising in fifty-eight different national magazines with eight full pages per magazine per year are included in the latest schedule of the Brunswick-Balke-Collender Co. advertising department. A. J. Kendrick, of this company, states that the campaign is for the purpose of enhancing the value of the Brunswick phonograph franchise, and more firmly intrenching the merits of this instrument as a standard in the mind of the general public. He believes that within a short time the trade is destined to experience a period of overproduction, when it will be a case of the survival of the fittest for dealers and manufacturers alike. Thus this policy will protect Brunswick interests by automatically increasing the demand for this particular machine through advertising, while at the same time increasing production.

Right in line with this campaign to establish the Brunswick more firmly in the favor of the general public and consequently to increase the value of the Brunswick franchise, plans are in train to make the productive power of these franchises equal to their potentially increased value and prestige. Dealers will be given opportunity to demonstrate that their interest and business-getting ability are up to the Brunswick standard. Representatives will go out to coach dealers in retail sales and service, giving actual demonstrations of how best to conduct a profitable and permanent business. If a dealer shows his willingness to co-operate with the manufacturers and is able to take a prominent place

**Equip Your Phonographs With Perfect Automatic Brakes**

Samples \$1.00 Each  
Cash with order  
State make of tone arm used



Also made with long brake shoe for 1 inch offset

Patented Aug. 28, '17

Simple construction and easily attached. Made in four styles to fit any make of tone arm.

Write for attractive quantity price

**PERFECT AUTOMATIC BRAKE CO.**  
Room 400, 425 S. Wabash Ave., Chicago

in the talking machine industry of his particular locality, he will be given the unlimited support of the Brunswick-Balke organization, but, on the other hand, if he demonstrates that he is not capable of this franchise, efforts will be made to transfer the agency.

The addition of Brunswick records to their line of talking machines has greatly increased the value of these agencies. Dealers who have already had great success with this line even without records, now expect even greater profits with them. Brunswick records as well as Brunswick machines will be strongly featured in the new national advertising campaign.

**BIG VITANOLA CO. PURCHASE**

New Property Acquired by Large Chicago Concern Adjoining Present Plant in Cicero

CHICAGO, ILL., April 5.—The Vitonola Talking Machine Co. has purchased 100 by 600 square feet north of and adjoining its plant at South Fifty-second avenue and West Nineteenth street, and will at once begin work on a \$300,000 veneer panel plant, dry kiln and lumber storage warehouse. The property was purchased from Philip A. Falk for an indicated price of \$36,000. The company has a large plant occupying over three and a half acres just south of this purchase, in addition to a plant at 503 West Thirty-fifth street, and another at Saginaw, Mich.

The recent purchase is in accordance with the Vitonola policy of expansion, and will further facilitate its plans for greatly increased production henceforth. The demand for Vitonola product has been very great during the last fourteen months, and it is still growing.



HERE IT IS

The

**FLETCHER UNIVERSAL TONE ARM and REPRODUCER**

Gives Proper Playing Weights for all Records. No Adjustment Screws or Springs.

SAMPLES \$8.00

Specify 8½" or 9½" arm

**FLETCHER-WICKES CO., 6 East Lake Street, Chicago, Illinois**

THE GEORGE McLAGAN FURNITURE CO., STRATFORD, ONTARIO, EXCLUSIVE CANADIAN AGENTS



# FERRO TALKING MACHINE PRODUCTS

A HIGH STANDARD OF QUALITY

## THE FERRO MOTOR

The LARGEST and Most POWERFUL Phonograph Motor in Existence

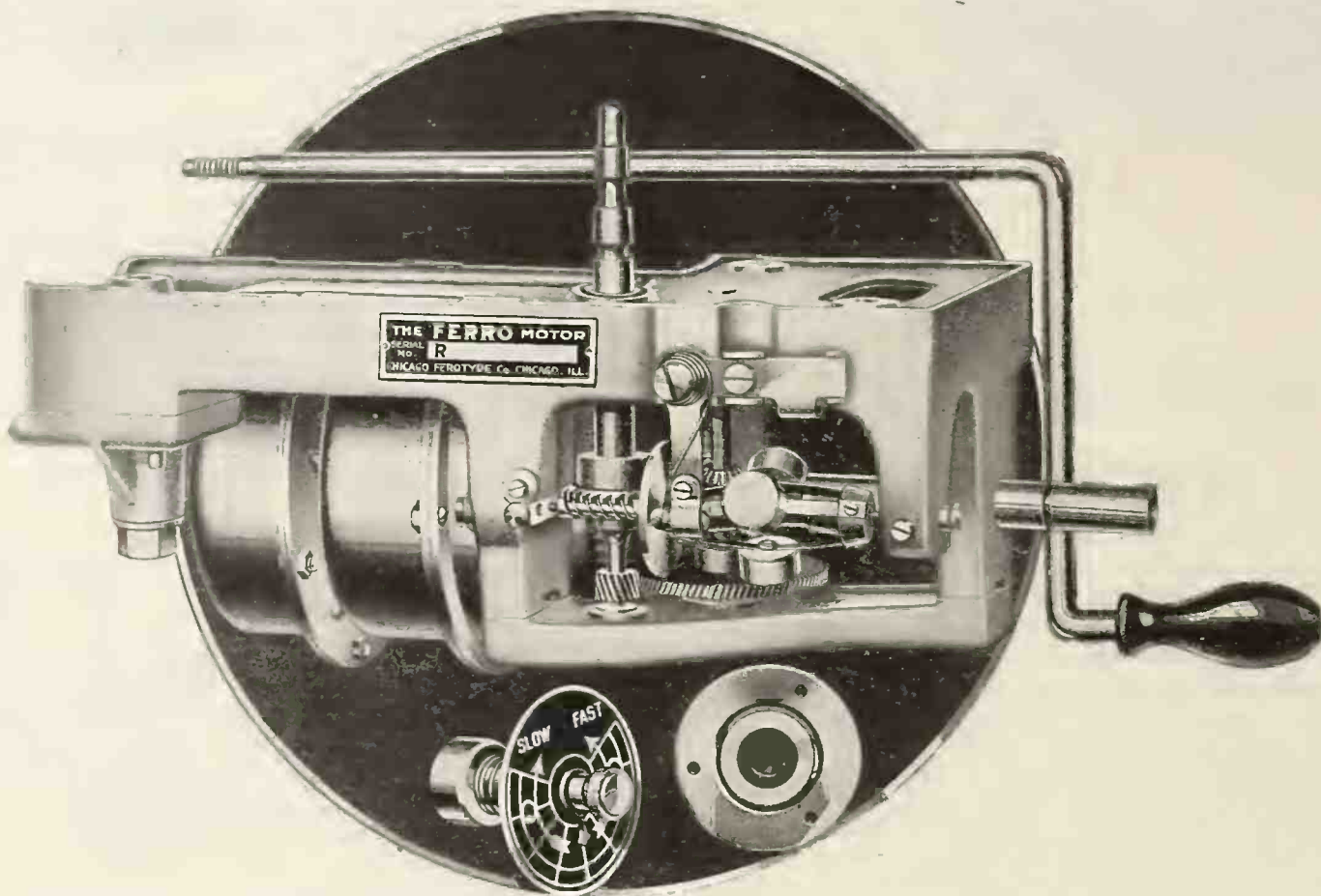

THE  
HEART  
of the  
TALKING  
MACHINE

The FERRO motor possesses all the qualifications that a phonograph motor should have—POWER—STRENGTH—DURABILITY—and it runs SMOOTHLY and NOISELESSLY.

To the phonograph manufacturer or assembler who wants a HIGH-GRADE—a BETTER motor, we say—"Don't fail to investigate our proposition."

### The FERRO Automatic Stop

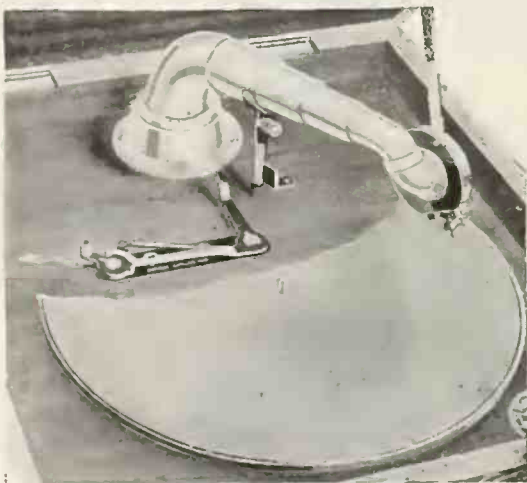

100% EFFICIENT

We are receiving nothing but praise regarding the FERRO-STOP. Why? Because it can be depended upon to stop the motor where you want it to stop; it is neat and simple and improves the appearance of the phonograph; it has no intricate mechanism, nothing to get out of order. The FERRO-STOP is guaranteed for five years.

If you want an accurate, perfect working automatic stop—one that will be an asset in the sale of your talking machines—then you want the FERRO-STOP.

### The FERRO Tone Arm and Reproducer

The FERRO tone arm and reproducer is in a class all by itself. It is a re-creator of sound waves and reproduces them exactly as they have been recorded.

A HIGH-GRADE sound reproducing unit for HIGH-GRADE phonographs.

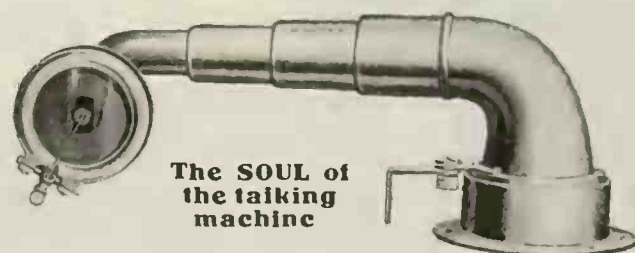

The SOUL of  
the talking  
machine

**CHICAGO FERROTYPE CO.**

**PHONOGRAPH PARTS DIVISION**

1455 W. CONGRESS STREET, CHICAGO, ILL.



FROM OUR CHICAGO HEADQUARTERS—(Continued from page 155)

## VALUE AND IMPORTANCE OF RECORD DISPLAY

By H. L. COOMBS, Assistant Sales Manager General Phonograph Corp. of Illinois

The greatest opportunity for the talking machine dealer of to-day to identify himself in his particular community as a live and progressive merchant desiring to give his customers the utmost in service is through talking machine records. Newspaper advertising and window display of instruments themselves offer great opportunities along this line, but not

sighted merchant that looks at it this way. The live dealer cannot afford to. Because he can not get all the records he can sell is no reason for a let-up in his efforts, as present conditions are not going to continue forever. The importance of good window display and local advertising is greater now than at any other time. In times of prosperity the merchant or



Artistic Display in Window of F. S. Spofford, Sonora Representative, in Republic Building nearly so great as are talking machine records, which permit of varied and attractive publicity and window display. Prestige, indeed, may be gained by the kind and character of the advertising of the instruments, but it is the records, and especially the latest hits, that enable the advertiser to put the "pep" into his business which lets the public know he is alive. The importance of record display is shown by the greatly increased service the record manufacturer is now giving the dealer along this line and by the many attractive windows which meet the eye on every side wherever talking machines are sold.

Operating under present conditions the retailers would seem to have very little incentive to increase activities and efforts in the way of pushing their records, but it is only the short-

manufacturer in any line has a golden opportunity to establish his wares on a permanent basis that will show the result when the less prosperous times come around. I mean that to-day, when records are selling big and record manufacturers are unable to supply the demand, the dealer has an opportunity, through progressive methods of advertising and window display, to establish a reputation that later, when conditions are reversed and supply is in excess of demand, will draw him the business.

Let us look at the various methods the retail talking machine merchant has of expressing himself to his clientele.

First, there is local advertising in newspapers and other mediums. By these means the merchant reaches the greatest number of people. It can be used to generally build up his record

business by advertising the comforts, conveniences, service, etc., of his particular store; or it can be used to convey information of the latest releases to the newspaper-reading public. This last is timely advertising and perhaps shows the most immediate results, but when used in conjunction with the former will prove the best in the long run. For newspaper advertising the Okeh service department prepares each month cuts suitable for appropriate display. These list the latest "hits" of the month and feature them in a way that brings them to the public eye in an attractive way, thus creating a desire to have the records in the home and "pulling" the customers into the store.

Coupled with the newspaper advertising is the window display of the dealer. This can be made further to influence the customer along the road that leads to sales. It must be timely. If a certain number is prominently featured in the dealer's newspaper advertising, so, also,

(Continued on page 159)

## LAKESIDE PHONOGRAPH PRODUCTS

WE CARRY A FULL LINE OF MOTORS, TONE ARMS, ACCESSORIES AND HARDWARE.

SEND FOR OUR NEW CATALOG NOW ON THE PRESS.

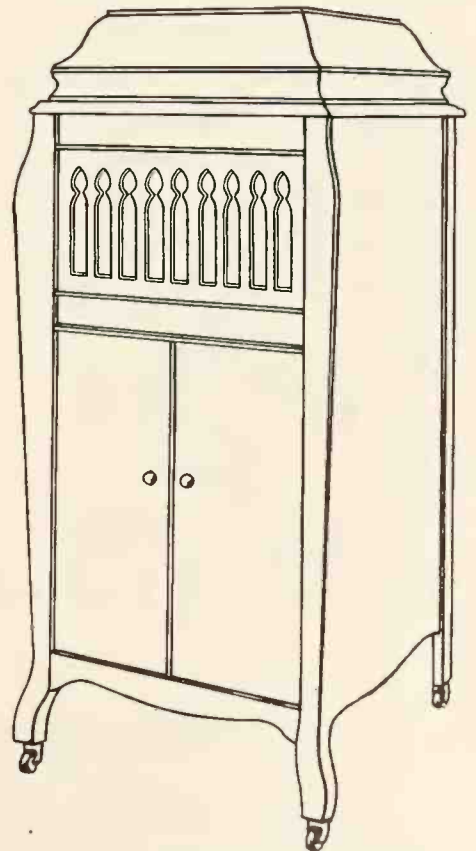

### CAN YOU BEAT IT! LAKESIDE ELECTROPHONE

An Electric Driven Phonograph

DEALERS WRITE FOR DISCOUNTS      RETAIL \$135.00

Furnished in All Standard Finishes  
45" High, 18 7/8" Wide, 21" Deep

*Lakeside Supply Co.*

Telephone Harrison 3840  
416 S. Dearborn St. Chicago, Ill.

## Prepare for Safe Handling

Insure Perfect Delivery

Khaki Moving Cover, Padded Fleeced Lined

Price \$8.50

Mention Style of Machine when ordering



No. 804



Heavily Padded and Quilted

Jobbers: Write for Special Offer

LYON & HEALY

CHICAGO



# "MAESTRO"

(The Leader)

Here is the Most Remarkable Offer ever made in the Talking Machine Trade. Just One of Six Wonderful Machines, all built in Our Own Factory with a Yearly Output of 50,000 Machines

## Read This Offer

### *Mr. Salesman:*

Are you satisfied with your present earnings and connections? Are you open for a better and bigger opportunity than has ever come your way? If so, write us to-day.

*We want men now in the \$10,000 a year class who are capable of earning more by making the change we offer.*

Three  
Upright Models  
Three  
Wonderful Sellers



MAESTRO  
140  
48" High  
20" Wide  
23" Deep

## Read This Offer

### *Mr. Distributor:*

Are you getting all that's coming to you in the way of profits — and deliveries when wanted? We have an interesting story to tell you, together with a wonderful selling plan.

*We want to get in touch with Distributors who can place our machines in their respective territories —and "clean up" on them.*

Three  
Console Models  
Three  
Trade Winners

The Cabinets for "Maestro" Phonographs are built complete in Our Own Factory—of genuine 5-ply Mahogany Veneer and are Masterpieces of Cabinet Workmanship—the equipment second to none now on the market. Make us prove this

*Write or Wire for Open Territory*

## LANSKI COMPANY, MANUFACTURERS

Sales Department, 1414-1420 So. Wabash Avenue, CHICAGO



**THE VALUE OF RECORD DISPLAY**

*(Continued from page 157)*

must it be prominently featured in his window. The one aids the other, if each is properly planned. The Okeh service department prepares each month a series of hangers, in colors, illustrating the current numbers. In addition there are large show cards which can be used from month to month and which feature no particular record, but call attention to the window by their attractive and snappy arrangement. There are also streamers supplied of each individual record which can be placed about the window calling attention to the numbers of the month. In connection with the record window display the importance of the "now-on-sale" streamers is not to be under-emphasized. This little message, if not left in the window for too long a period each month, will get passersby in the habit of watching for it.

The window display should be properly balanced, so that it is pleasing to the eye. The music lover is a natural critic of anything unharmonious, and if there is reason for artistic display in any line of merchandise it is in the display of talking machines and records. In the window and in the store the differences between a good and successful dealer and a poor and unsuccessful one are shown in the spirit of the sales force, the character of the surroundings and the originality of the window trimmer. However, if there is to be a choice between an "original" window trimmer and a "tasteful" one the latter is to be preferred. In other words, originality is no good unless it is accompanied by good taste.

Now we reach the third medium possessed by the dealer for reaching his customers: the direct-by-mail method. The Okeh service department supplies each month in this connection a series of "stuffers" for mailing out to their dealer's retail trade. The "pulling" power of direct-by-mail advertising is great and can be used by the local merchant with great suc-

cess. But the mailing of literature must be regular and not spasmodic; furthermore it must be interesting and of a nature that will be read. Every owner of a talking machine is ready to buy more records if he can be shown what he wants, and the direct-by-mail method is unexcelled in this respect.

**BRING CARUSO TO NEW ORLEANS**

Philip Werlein, Ltd., Creates Furore With Announcement of Great Tenor's Coming

They can talk about the "wait-until-to-morrow-and-I'll-do-it" spirit in the South, but Philip Werlein, Ltd., didn't show it when it signed the contract for Caruso's appearance in New Orleans, May 4. At 4:50 p. m., March 26, the contract was signed. At 8:30 a. m., March 27, it was announced with a 30-foot by 10-foot sign adorning the front of the store and the morning paper used a two-column picture of Caruso with a news notice of his coming appearance. The afternoon papers did likewise.

Then the furore started. It is conceded the coming of Caruso to New Orleans is epochal. Nothing has created such an interest since the days of Jennie Lind, before the Civil War. Never has a music house or talking machine distributor in the South received more laudatory comments than Werleins. They are distributors for the Victor line, but in none of their advertising of Caruso's coming has the word Victor been used thus far.

The record time for getting the sign painted and getting it hung was commented upon greatly and P. M. Harris, sales manager, was complimented for his ability to get it done with such dispatch. Mr. Harris attributes this to one important thing—making people like you and do things for you hurriedly.

The Oakford Music Co., Omaha, Neb., has just installed a completely new set of demonstration booths in the store at Eighteenth and Farnum streets.

**PHILADELPHIA DEALERS MEET**

Victor Dealers' Association Listens to Interesting Address by E. J. Dingley

PHILADELPHIA, Pa., March 31.—The regular monthly session of the Philadelphia Victor Dealers' Association, held at the Bellevue-Stratford Hotel on March 18, proved one of the most successful and interesting sessions yet held by that organization, attracting dealers from suburban districts as well as those in the city proper.

A large number of travelers and jobbers' representatives were present by invitation and listened to an interesting address by E. J. Dingley, manager of the machine order department of the Victor Co., in the course of which he outlined factory conditions as they affect production at the present time. He told the dealers of the successful effort being made to increase production and gave them much food for optimistic thought.

J. R. Wilson, president of the Association, presided at the session, during the course of which there was considerable routine business handled.

**VICTOR CO. VS. INDEPENDENT CO.**

Bill of Complaint, Charging Patent Infringement, Filed Against New York Concern

The Victor Talking Machine Co. filed its bill of complaint against the Independent Talking Machine Co., Inc., of New York, on April 1, 1920, in the United States District Court, Southern District, of New York, for infringement of the Johnson Talking Machine Patents, Nos. 814,786 and 814,848, and for unfair competition in "imitating the dress, appearance, ornamentation and other distinctive characteristics" of its machines.

An order to show cause why preliminary injunction should not issue has been made by the court and set for hearing on April 16, 1920.

**GUARANTEED**

Model No. 2150 D.D.  
2 Units Illustrated.

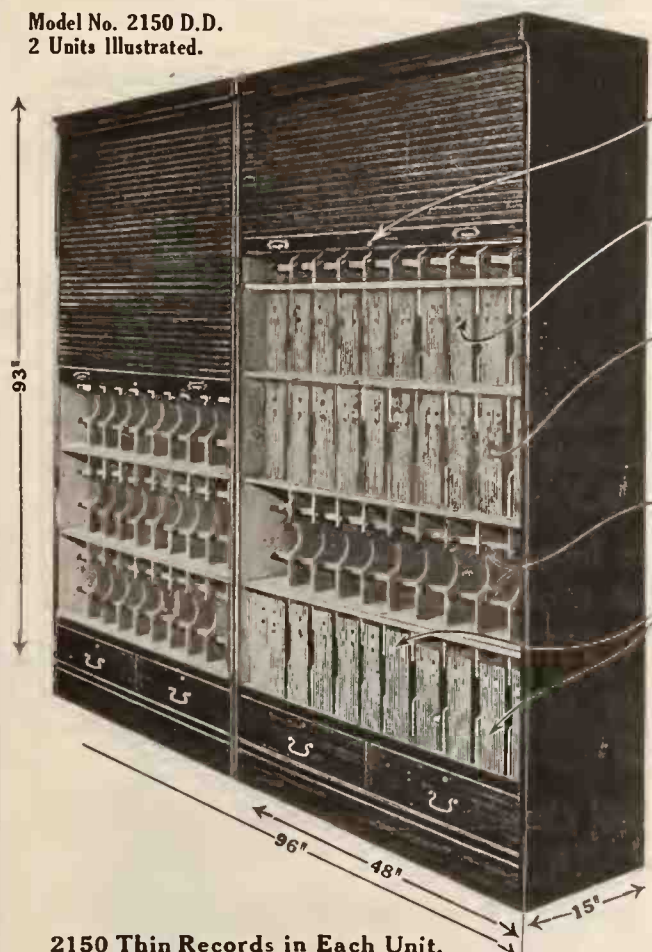

Locking RollTop Prevents Dust and Theft, also supplied with Spanish Leather Curtain.

350 10" or 10 1/2" Records on each shelf. Filed in Sales System Covers and with Index Guides.

350 10" or 10 1/2" Records on this shelf, also 3 shelves above.

Soft Flat Supporting Springs Prevent Warping (Patented). Holds 350 10" or 12" records.

10 and 12" Records Filed on same shelf. Held Flush at the front by Patented Adjuster.

Sectional Models Fit Any Size Stock and Help You Grow



The Ogden Sales System Is Equivalent to an Extra Clerk and Increases Sales.

**File Your Records so you can find them and it's easy to sell them.**

This System pays for itself by increasing Sales through better service and Automatic ordering of "Sold Out" Records.

**Secure These From Your Jobber:**

**COLUMBIA DISTRIBUTORS**

Columbia Co., All Branches.  
Tampa Hardware Co.

**EDISON DISTRIBUTORS**

Harger & Blish.  
C. B. Haynes Co., Inc.  
Laurence H. Lucker.  
Montana Phonograph Co.  
Phonographs, Inc.  
The Phono Co. of Chicago.  
The Phono. Co. of Cincinnati.  
The Phono Co. of Detroit.  
The Phono. Co. of Kansas City.  
The Phono Co. of Milwaukee.

**VICTOR DISTRIBUTORS**

W. D. & C. N. Andrews  
Badger Talking Machine Co.  
Blackman Talking Machine Co.  
C. Bruno & Son, Inc.  
Louis Buehn Co., Inc.  
The Cleveland Talking Machine Co.  
The John Elliott Clark Co.  
Cohen & Hughes.  
W. J. Dyer & Bro.  
Elmira Arms Co.  
Eclipse Musical Co.  
Elyea Talking Machine Co.  
J. W. Jenkins' Sons Music Co.  
Mickel Bros. Co., Des Moines.  
Mickel Bros. Co., Omaha.  
Putnam-Page Co.  
Stewart Talking Machine Co.  
The Toledo Talking Machine Co.  
Talking Machine Co., Birmingham.  
The Perry B. Whitsit Co.

**OTHER DISTRIBUTORS**

Buffalo Wholesale Hardware Co.  
Interstate Phonograph Co.  
C. M. McClurg & Co.  
Cabinet & Accessories Co.  
Sonora Dist. Co. of Texas.  
Yahr & Lange Co.  
Crafts-Starr Phono. Co.  
W. H. Caldwell.  
M. Sellers & Co.

**SALESMEN**

H. A. Copeland.  
W. O. Harris.

**Ogden Sectional Cabinet Co., Inc.**

LYNCHBURG, VA.



# The Puritan

## An Opportunity for Dealers

The PURITAN Phonograph literally "speaks for itself."

There is a richness and purity in the reproduction, quite different from other instruments, that invariably pleases the listener.

The most critical music-lovers declare that such smoothness, clearness and volume of tone have never been produced by ordinary phonographs.



### THE REPRODUCER

A new type of sound-box and tone arm give absolutely free horizontal and vertical movement, enabling the needle to receive ALL THE IMPULSES from the corrugations of the record. The faintest recorded sounds are faithfully transmitted to the ear. The mechanism is very sensitive to record vibrations, and is the result of long experiment.

The great clearness of tone in the PURITAN is produced by the

### LONG WOOD HORN

This is an exclusive, patented feature, and CANNOT BE USED BY ANY OTHER MANUFACTURER.

The PURITAN HORN is a rectangular channel representing an organ-pipe, extending from the tone arm to the bottom of cabinet. It has only one bend (see illustration).

### THIS IS THE MOST EFFECTIVE AMPLIFIER EVER PRODUCED

The PURITAN HORN magnifies and mellows the vibrations from the diaphragm. At the same time it absorbs all hissing and grinding sounds, delivering the MUSIC ONLY in a wonderfully realistic way.

The entire instrument, including motor, sound-box and cabinet, is made in our own factory, and we guarantee every part.

### PURITAN LATERAL-CUT RECORDS ARE BRILLIANT AND CONTAIN THE LATEST POPULAR NUMBERS

*The Puritan Phonograph plays all makes of Disc Records, with all the distinctness and volume of which the record is capable*

EIGHT BEAUTIFUL MODELS NOW READY FOR IMMEDIATE SHIPMENT  
WRITE FOR CATALOG AND DEALERSHIP PROPOSITION

# United Phonographs Corporation

Factory and General Offices: Sheboygan, Wisconsin



**REPAIRING DAMAGES TO CABINETS**

Short Cuts and Hints Which Dealers Have Found by Experience Helpful in Repairing Damage Occasioned by Transportation

The number of talking machine cabinets which are damaged in transit, in spite of careful packing and extra precautions taken by the shipping departments, makes necessary considerable repair work in the dealer's store after every shipment arrives. Freight and express handlers still seem to lack the gentle touch and to dealers who have had machines arrive slightly damaged, the following points may be of interest:

"After carefully unpacking the phonograph, wipe it off with a piece of fine cheesecloth to remove all dirt and marks of packing. Then with a clean piece of cheesecloth rub the cabinet with a small portion of cleaner. Never use ready-made liquid polishes which are so extensively advertised as wonder workers. They will make the surface sticky, spotted and clouded, and destroy the finish.

"By mixing three parts benzine to one part paraffin rubbing oil you will have the best possible cleaner and polisher for a cabinet. Rub briskly, always lengthwise to the grain, cleaning off all surplus polish. Brush out all the corners with a brush, preferably a soft, round three-bristle varnish brush. If paper has become stuck to the cabinet it can easily be removed with a cloth and water. The cabinet should then be carefully dried and the surface rubbed with a 3F pumice stone, a soft felt and paraffin oil. Care should always be taken to rub lengthwise to the grain.

"Never sponge a cabinet and then expose it to the sun in the show window. The glass intensifies the heat which will blister the varnish, fade the color and ruin the whole finish. When this happens the whole finish must be removed by an expert mechanic, refinished and French polished.

"Bruises or scratches should be rubbed out with a piece of soft felt, a 3-F pumice stone and paraffin rubbing oil. Go only so far as the body varnish will permit and rub only lengthwise. If the bruise or scratch is too deep to rub out, it will have to be burned in with shellac cement, the spot leveled up with fine sandpaper and touched up to the required color. It will then be necessary to French polish it with a solution of shellac, alcohol and raw linseed oil, using a piece of cotton covered with a piece of fine linen cloth. This requires skill and experience and should never be attempted on a large flat surface by a novice.

"Rubber spots and white corners on a red mahogany cabinet can be touched up with spirit stain made from Bismarck brown, dissolved in alcohol to which a little shellac is added. For English brown finished cabinets add a little nigrosine to the above-mentioned solution. Special finishes and oak require the color adapted to the finish. If after treating the cabinet in any or all of these ways scratches

# MORE PHONOGRAPH SALES IN 1920

## IF YOU HANDLE THE CHORISTER



**"LEADER OF THEM ALL"**

Have we told you about our new amplifying chamber?

*Write now for prices and illustrations*

**Chorister Phonograph Co.**  
336-38 West 63rd Street  
**CHICAGO**  
TELEPHONE ENGLEWOOD 1979

and marks still show it will be necessary to employ a skilled polisher to French polish the whole cabinet to the desired finish, which must then be dulled off with a soft brush dipped in 3-F pumice stone and cleaned up as before mentioned. If the finish has turned gray or become spotted by being exposed to dampness or some other unusual conditions, the whole finish will have to be removed by an experienced wood finisher and refinished as above mentioned."

**NEW ACCESSORY COMPANY**

The Esco Music & Accessories Co. has been recently formed in Brooklyn, N. Y., to conduct a general talking machine accessories business. Offices have been opened at 137 Lawrence street; the destinies of the new company will be directed by Oscar Zepernick and Joseph Kerr, both formerly connected with the Cabinet & Accessories Co. This company reports that it has already secured the agency for the Portophone and a number of well-known accessories and that this list will be added to from month to month.

The Tucker Piano Co. of Fort William, Ont., Edison and Columbia dealer, has installed new sound-proof demonstration rooms in its store. The rooms are finished in white enamel and are typical of the progressive policies of the company.

**VISITORS AT PORTLAND FACTORIES**

Industrial Development Committee Arranges Educational Program Showing Growth in Manufacturing Interests of the City

PORTLAND, ORE., April 6.—One of the interesting happenings in the talking machine circles here recently was a visitors' day at the three Portland talking machine manufacturing plants—the "Emerson" factory at 500 East Lincoln street, the "Cremona" plant at 351 East Tenth street, and the Pacific Phonograph Co.'s factory at East Thirty-third and Broadway. The three plants were open to visitors all day and the public is urged to investigate the interesting processes of phonograph manufacture.

The visit was arranged as a part of the educational program outlined by the industrial development committee of the Associated Civic clubs and was given under the direct auspices of the Portland Realty Board. Similar visits will be made to other industrial plants each Thursday during the Summer.

A feature of the visit was the gift of a mahogany "Stradivara" phonograph to one of the visitors at the Pacific Phonograph Co.'s plant under an arrangement with the Portland Realty Board.

The Ohio Talking Machine Co., Cincinnati, O., has been incorporated with a capital of \$200,000 by J. L. Lachner, C. Southworth, R. deV. Carroll, W. W. Morris and R. E. Freer.

## Mr. Dealer

**There is something you need. We cater to small and large orders with prompt service.**



*The Portophone plays any disc record with perfect tone*

Container in Lid Holds Twenty-four Selections

Attachments for Victrolas and Columbia Grafonolas to play all makes of records.

Fidelity genuine Swiss jewel Edison and Pathé needles.

Tri-Trola attachments for playing all records on Edison Phonographs.

Ragtime Rastus.

Boxers.

Tri-Trola Speed Indicators.

Phono-Movies and other Dancing Dolls.

Glo Rite—Phonograph and Piano Cream for polishing.

Highest Grade steel needles.

Tri-Trola Reproducers.

Repeater-Stop.

Albums and all Accessories.

**NEEDLE HOLDER**

*A Necessity*

Holds Edison and Pathe Needles



For All Phonographs

## The Tri-Sales Co.

**Victoria Bldg. St. Louis, Mo.**



# SOUNDNESS AND SOLIDITY

**Simple Words:**—but they stand for the most important qualities a business—an article of manufacture or a business man—can possess.

These qualities are needed today as they never were needed. The wise dealer will anchor his business to them as to a rock. He will therefore be irresistibly attracted towards

*The Widdicomb*  
A FINISHED  
PRODUCT

The product of an organization which has fifty years of splendid repute behind it, for skill in the art of wood fashioning; with mechanical equipment unsurpassed and tonal qualities superb, the WIDDICOMB is THE phonograph par excellence for the discriminating dealer who looks for Quality Trade.

~~~~~  
Pertinent details for the asking  
~~~~~

PHONOGRAPH DIVISION

**WIDDICOMB FURNITURE CO.**

GRAND RAPIDS, MICH.



WIDDICOMB No. 5.



## JOBBER VISIT PUTNAM-PAGE CO.

Several of Those Attending Sessions of Association in Chicago Stop Off at Peoria

PEORIA, ILL., April 3.—Peoria is becoming quite a center for talking machine trade and a number of people prominent in the industry have spent considerable time in and about Peoria visiting talking machine people during the last month.

Two important visitors of the month were Louis Buehn, president of the Louis Buehn Co., Philadelphia, and J. Newcomb Blackman, president of the Blackman Talking Machine Co., New York. These gentlemen visited the Victor distributing organization of the Putnam-Page Co. previous to attending the conference of the National Association of Talking Machine Jobbers in Chicago. They were guests of F. H. Putnam at a dinner at the Peoria Country Club during their stay and they were accompanied to Chicago by Mr. Putnam and P. A. Ware, sales manager of Putnam-Page Co.

A. R. Boone, president of the Talking Machine Co. of Birmingham, Ala., spent two days in Peoria, following the jobbers' conference in Chicago, during which time he inspected the Putnam-Page Co. organization. The visit was made in connection with a tour made by Mr. Boone, who is studying the best methods of Victor distribution among progressive wholesalers in that line.

Miss Esther A. Godehn and Miss Helfried Norstrom, of the Norberg Co., Victor dealers at Moline, Ill., who attended the Victor School at Camden, visited the headquarters of the Putnam-Page Co., in company with Miss Etta Park, who is a Red Seal expert in the store of Duncan & Schell, at Keokuk, Ia.

Roy Page, secretary of the Putnam-Page Co., has returned from Camden, where he took the Victor Service Course. During his trip East Mr. Page attended the talking machine conference in New York, representing his company.

## J. P. SEEBURG VISITS NEW YORK

J. P. Seeburg, president of the Marshall Piano Co., arrived in New York recently with his wife. His visit was primarily for the purpose of seeing his wife off to Europe. Mrs. Seeburg left on March 31 on the "Cretic," of the White Star Line, for Naples. She will remain in Europe about six months, spending most of her time in Italy, France and Belgium.

## HELD A SPECIAL MEETING

A special meeting of the stockholders of the General Phonograph Corp. was scheduled for April 15 at the offices of the company, 25 West Forty-fifth street, New York. The object of the meeting was to consider and vote upon a proposition whether the number of directors of the company shall be increased from eleven, the present number, to fourteen.

# Victor Dealers—

will find in our new wholesale store every facility for the marketing of

## VICTROLAS and RECORDS

Our New Location at

**Penn Avenue and 12th Street**

brings our wholesale department to within one block of the Pennsylvania Station.

**Be Sure to visit the Model Victor**

Sales Room on the first floor.

**Mellor's**  
PITTSBURGH, PA.



## ADOPTS NEW DISTRIBUTING PLAN

**Excel Cabinet Co. Now Sending Out Machines on Approval to Retailers**

The Excel Cabinet Co., 336 West Twenty-third street, New York, has recently inaugurated a new policy in introducing its products to the dealers. Under the new plan sample machines are sent to the dealers on approval, to be paid for if satisfactory, or otherwise returned. The company's sales staff has been enlarged materially during the last few months and a special point is being made of dealers' service. The three factories, in Benton Harbor and Holland, Mich., and Chicago, Ill., are said to be working to full capacity in order to meet demands. The company is now working on some live publicity material for the dealers.

## INCREASES SELLING FORCE

The Cabinet & Accessories Co. has added the new portable Cirola phonograph to the large list of phonographs and accessories which it distributes. Two new men have been added to the sales staff of the organization: E. Wilson, at one time with the S. B. Davega Co., and more lately with Ormes, Inc., and Chauncey J. Kavanagh, formerly connected with the Pathé Frères Phonograph Co. These men will succeed Joe Parr and Oscar Zepernick, who have resigned from the organization.

## INDIANAPOLIS PATHE MEN MEET

**J. M. Wallace Elected President of Retail Pathé Dealers' Association—Other Conferences Will Be Held in the East Later**

INDIANAPOLIS, IND., April 5.—The Retail Pathé Dealers' Association was organized here recently at a meeting of Pathé dealers under the auspices of the Mooney-Ward-Mueller Co., Pathé distributors of this city. The following officers were elected: President, J. M. Wallace, of the Wallace Music Co., of Marion, Ind.; secretary, H. G. May, of Princeton, Ind. These officers are authorized to speak for the Association at conferences to be held in the East. These conferences will be between the officials of the Pathé Frères Phonograph Co. and the dealers, and, it is expected, will be of great mutual benefit. One hundred dealers were present at the first meeting and the business session was followed by a banquet.

## WINS SUCCESS IN CHICAGO TRADE

One of the coming factors in the retail talking machine trade of Chicago is Nate Frank, who conducts a live store at 844 East Sixty-third street, where he features Okeh records as well as lines of machines. Mr. Frank now has two record booths and contemplates the installation of six additional booths to take care of the growing business.

# WAGNER PHONOGRAPH CO.



## Offers to the Trade:

**Motors—Double and Triple Spring, of any standard make**  
**Needles—Brilliantone, any tone :: Cabinets—Any size and price**  
**Tone Arms, Soundboxes, Springs, Lid Supports, Turntable Felts**

**Large Selections in Standard Make RECORDS**

**139 EAST FIFTY-FOURTH STREET.. NEW YORK CITY**



# Pathé Records

*Sales and Profits  
One Continuous Stream*



## Every Phonograph has a Turntable

For EVERY turntable on EVERY Phonograph is a place for you to put Pathé Records at a profit. We say Pathé Records—We MEAN Pathé Records—because:

Every day the demand for Pathé Records increases.

Every day more people recognize the exquisite tone quality of Pathé Records.

Every day more people discover that Pathé is first with the hits that make Broadway famous.

Every day people find out that they get the widest possible choice in Pathé Records—everything in music—operatic, orchestral, band and vocal—from the classical favorites and the “songs that never grow old” to the raggy, jazzy popular melodies of the day.

How are they making their discoveries so fast? The answer. Pathé national advertising: It is effectively telling the public about Pathé Records day by day, week by week, month by month. And every time every 24 hours go by, ten times that many people right in YOUR neighborhood have discovered that Pathé Records give them the music they want—and surpassing tone.

*There is no question as to Pathé Record Superiority*

### **PATHÉ FRÈRES PHONOGRAPH CO.**

EUGENE A. WIDMANN, Pres.

10<sup>1</sup>/<sub>2</sub> to 56 Grand Ave., Brooklyn, N. Y., U. S. A.

and London, Eng.

The Pathé Frères Phonograph Co.  
of Canada, Ltd.,  
Toronto

Pathé Records,  
Made in America,  
But World-wide on  
Their Repertoire



# Supreme

SUPREME in design  
 SUPREME in construction  
 SUPREME in material  
 SUPREME in repertoire  
 SUPREME in tone  
 SUPREME in prestige

**Pathé**  
 REG. U.S. PAT. OFF.  
**PHONOGRAPH**



To merchants, desirous and capable of handling a really high class proposition of national prestige, the Pathé Phonograph must prominently commend itself.

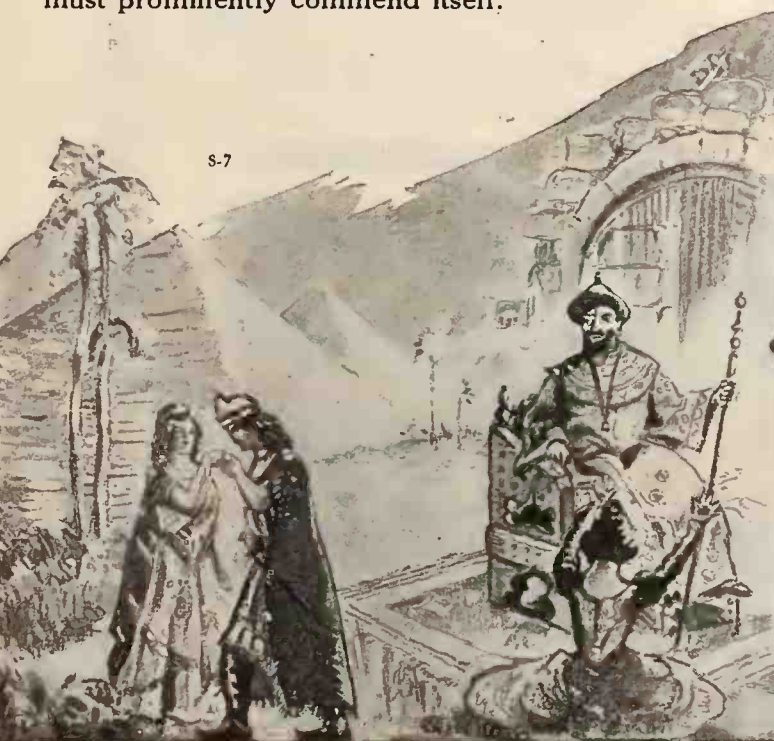

Write for the free book "The Other 20%"

**PATHÉ FRÈRES PHONOGRAPH CO.**

10-56 GRAND AVENUE  
 and London, England

BROOKLYN, N. Y., U. S. A.  
 The Pathé Frères Phonograph Co. of Canada, Ltd., Toronto



# QUALITY LEADERS IN THE CABINET FIELD



Style 71.—Mahogany, Golden Oak, Fumed Oak, Weathered Oak. Height 33 3/4 in. Top 17 1/4 x 17 1/2 in. Holds 168 12-in. Records. For Victrolas IV-A and VI-A; Columbia No. 25 and No. 35.



Style 24.—Mahogany, Golden Oak, Fumed Oak, Weathered Oak. Mahogany has Mahogany front door; Oak has Quartered Oak front door. Height 33 in. Top 17 x 17 in. Holds 168 12-inch Records. For Victrolas IV-A and VI-A; Columbia No. 15, No. 25, No. 35.



Style 72.—Golden Oak, Fumed Oak, Weathered Oak. Height 34 in. Top 16 1/4 x 20 in. Holds 180 12-in. Records. Made specially for Victrola VIII-A. Top has countersunk holes to accommodate rubber bumpers on machine.



Style 86.—Mahogany, Golden Oak, Fumed Oak, Weathered Oak. Height 30 in. Top 19 1/4 x 22 3/4 in. Holds 96 12-in. Records. For Victrola IX-A; Columbia No. 50; Pathé No. 50.



Style 79.—Mahogany, Golden Oak, Fumed Oak, Weathered Oak. Height 34 in. Top 19 1/4 x 22 3/4 in. Holds 96 12-in. and 96 14-in. Records. For Victrola IX-A; Columbia No. 50; Pathé No. 50.



Style 32.—Mahogany, Golden Oak, Fumed Oak, Weathered Oak. Height 30 in. Top 24 x 20 in. Holds 126 12-in. Records. For Victrolas VIII-A and IX-A; Columbia No. 50; Pathé No. 50, and smaller machines.

Prompt deliveries on all orders. Write for Illustrated Catalog of complete line

**The Geo. A. Long  
Cabinet Company**  
HANOVER, PA.



Style 76.—Mahogany, Golden Oak, Fumed Oak, Weathered Oak. Mahogany has Mahogany front door; Oak has Quartered Oak front door. Height 34 in. Top 19 1/4 x 22 3/4 in. Holds 96 12-in. and 96 14-in. Records. For Victrola IX-A; Columbia No. 50; Pathé No. 50.

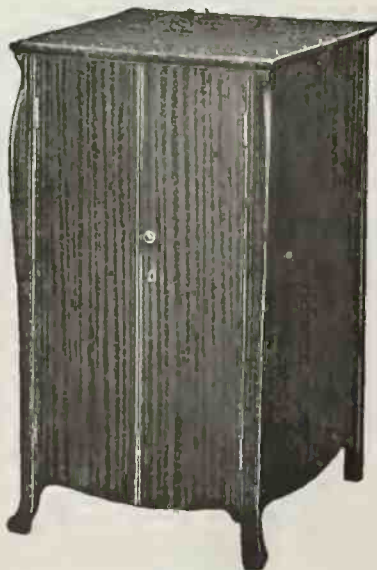

Style 77.—Mahogany, Golden Oak, Fumed Oak, Weathered Oak. Height 34 in. Top 19 1/4 x 22 3/4 in. Holds 96 12-in. and 96 14-in. Records. For Victrola IX-A; Columbia No. 50; Pathé No. 50.



Style 77.—Shows cabinet equipped with top moulding to be used only in connection with Victrola IX-A.



**PITTSBURGH HEARS ADDRESS ON IMPORTANCE OF MUSIC**

Association Listens to Address by C. M. Tremaine—Other Speakers—Leading Stores Pleased With Development of Business—John Fischer of Mellor's Tells of Sales Plans—News of Month

PITTSBURGH, Pa., April 5.—Emphasizing the need of music in the reconstruction process that is now under way in the country, C. M. Tremaine, of New York, director of the National Bureau for the Advancement of Music, made a very interesting and inspiring address before the Piano Merchants' Association of Pittsburgh at the Lincoln Club, on Monday evening last. Mr. Tremaine was the honor guest and had been invited to address the association, which is composed of the leading piano merchants of the Steel City, who also handle the standard lines of talking machines.

Mr. Tremaine's visit to Pittsburgh was primarily to speak on "Music Week," as plans are being made by the local piano merchants to hold a "Music Week" in Pittsburgh during the Fall of 1920. Mr. Tremaine spoke at some length and pointed out the advantages of a "Music Week" and asserted that the good that would accrue from it outside of the commercial aspect would be lasting and most beneficial to the trade at large. He said that the people wanted music, needed music and that the piano and talking machine were factors that could not be lightly considered in the reconstruction work. Mr. Tremaine said that the Central Powers well knew the power and influence of music and their victories in the early days of the war were principally due to music. But when the United States realized this power of music and utilized it the tide began to turn in favor of the armies of the Allies and associated powers.

Mr. Tremaine pointed out the fact that cities and towns could be stimulated to greater efforts for welfare and community work through the refining influences of good music, and stated that he would do all in his power to aid the "Music Week" movement in Pittsburgh. He made a number of valuable suggestions that were much appreciated by his hearers and at

the close of his talk he was given a rising vote of thanks.

M. V. DeForeest, of Sharon, Pa., first vice-president of the National Association of Music Merchants and a well-known Victor dealer, was present at the meeting and spoke briefly in advocacy of "Music Week" and "wished that it could be made a Music Week for the entire State." As a result of the talk of Mr. Tremaine and a brief outline of a proposed program by W. C. Hamilton, of the S. Hamilton Co., Victor and Columbia dealers, it was decided on motion of H. H. Fleer, of the C. C. Mellor Co., Victor distributors, to launch a movement to start "Music Week" in Pittsburgh. The committee named by President Hamilton will report at the April meeting. Among those present at the meeting were W. C. Dierks, of the C. C. Mellor Co.; A. O. Lechner and L. J. Schoenberger, of the Lechner & Schoenberger Co., Victor, Columbia and Edison dealers; C. L. Dawson, of Dawson Bros. Piano Co., Starr phonograph dealers; Theodore Hoffmann and Edward Hoffmann, of the J. M. Hoffmann Co., Brunswick phonograph dealers; L. H. Jacobi, Jr., of Kaufmann's, Victor dealers; E. B. Heyser and G. W. Watkins, of the W. F. Frederick Piano Co., Victor dealers; T. E. McCausland, Modernola and Empire dealer; W. H. McConnell, of Boggs & Buhl, Victor and Columbia dealers.

A. A. Buehn, president and general manager of the Buehn Phonograph Co., Edison distributors, accompanied by J. K. Nichols, E. J. Condon and Edward W. Voss, sales representatives, attended the meeting of Edison representatives in New York. Mr. Buehn stated that business conditions in his territory were very bright. At the retail store of the Buehn Co. during Holy Week there was an exhibition in the show window of a fac-simile painting of the noted work of the Hungarian artist, Munkacsy, entitled

"Christ Before Pilate," the original of which is owned by John Wanamaker, of Philadelphia. The painting attracted a great deal of interest. Wallace Russell, of the Standard Talking Machine Co., is back at his desk again, after a visit to Florida. French Nestor, also of the Standard Co., spent some time in the Sunny South prior to the going of Mr. Russell. J. C. Roush, president of the Standard Co., who is still in Florida, will not return for several weeks.

S. H. Nichols, manager of the Pittsburgh offices of the Columbia Graphophone Co., is taking a well-earned rest at Battle Creek, Mich. Edward Hoffmann, of the J. M. Hoffmann Co., Brunswick phonograph and Emerson and Okeh record dealers, returned from a pleasure trip to Bermuda.

W. H. Reed, Jr., of the Reed Co., Inc., distributors of the Regina phonographs and Operaphone records, is back from the Middle West after a very extensive and successful business trip. He reports the outlook for sales as the best in the history of the company, whose business is so rapidly expanding that new quarters in the East End district had to be secured.

J. A. Endres, district sales manager for the Brunswick, stated to The World representative that "Business in Brunswick phonographs and Brunswick records is fast exceeding our most sanguine expectations." Mr. Endres pointed out that the advertising plans of the Brunswick Co. were of so stupendous and comprehensive a nature that every Brunswick dealer would be greatly benefited and that his sales would be much increased. Mr. Endres has just returned from a trip through his territory and stated that all of the Brunswick dealers are highly pleased with the co-operation the Brunswick Co. extends to the trade. The sales and demonstration offices of Mr. Endres have been remodeled and enlarged for the convenience of the various Brunswick dealers, who will find a hearty welcome there during their visits to the city.

John Fischer, the well-known manager of the

(Continued on page 169)

**QUALITY** in the Vitaphone Motor is the result of years of mechanical manufacturing. It is a time-tested motor and not one that is slapped together and slammed into a case because many people are clamoring for motors.

**IF** we reduced our high standard of quality, we could **DOUBLE** shipments, but we want you to know when you buy or sell a Vitaphone motored phonograph that it is a distinct asset both as a profit maker and a business builder.

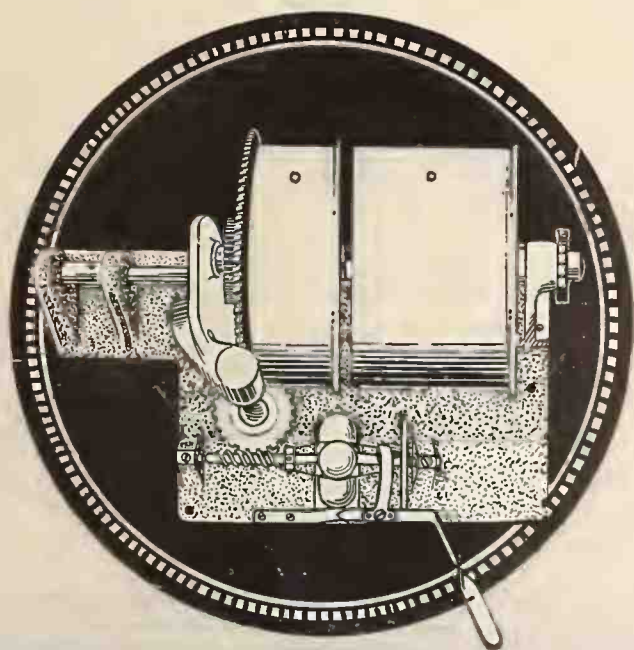

NATIONAL *Vitaphone* CORPORATION  
C. B. Repp, Pres. PLAINFIELD, N. J.





Edison Amberola Message No. 5

Cash registers of Amberola dealers are playing mighty lively tunes nowadays.

Systematic advertising, a reasonable selling price and the satisfaction of the public with both the Amberol Records and Diamond Amberola Phonographs are only a few reasons why the dealers and their cash registers are kept busy—and happy.

**THOMAS A. EDISON, Inc.**

AMBEROLA DEPARTMENT

ORANGE, N. J.



**TRADE HAPPENINGS IN PITTSBURGH**  
(Continued from page 167)

Victrola department of the C. C. Mellor Co., returned from a trip to Chicago, where he attended a meeting of the Victor jobbers. Mr. Fischer outlined a plan to The Talking Machine World representative of the methods used to dispose of the "in stock" records and records that "move slowly." The sales force of the retail department meets for a short time each morning before business starts and plans for the day are outlined in such a manner that there is perfect harmony and unity of action between the sales force the entire day.

I. Goldsmith, president of the Playertone Talking Machine Co., whose offices are located at 967 Liberty avenue, where spacious sales and show rooms are also maintained, stated to The World representative that sales of the Playertone talking machines have been most marked during the past month and that despite the car shortage and other transportation difficulties the company was able to make all shipments of Playertone talking machines practically on time. Mr. Goldsmith also referred to the fact that in response to a demand for a popular-priced phonograph a line of Master Tone phonographs was consigned to the Kaufmann & Baer Co., who placed the instruments on sale in the talking machine department.

Mr. Goldsmith stated that the demand far exceeded the supply, although several carloads formed the initial shipment. The Master Tone

line samples were placed in two of the large show windows of the Kaufmann & Baer Co.'s store and caused considerable interest on part of the public. Manager Pierce, of the talking machine department of the large store, emphasized the fact that he and his staff were kept "on the jump" for several days selling Master Tones.

P. W. Simon, the well-known Victrola man of Uniontown, Pa., who is responsible for the widespread knowledge and popularity of the Peerless Record Makers, returned recently from a trip through Eastern Canada with the entertainers. He reported packed houses at Montreal, Toronto, Ottawa, St. Catharines, London and Hamilton. The Peerless Record Makers have been assigned by Manager Simon to the following points during the next two weeks: April 12, Johnstown, Pa., Porch Bros. being the sponsors there for the entertainers; April 14, Altoona, Pa., auspices Jacob Sitnek; April 15, Latrobe, Pa., auspices G. M. Fincik & Co.; April 16, Irwin, Pa., auspices Robert Winter. On April 13 the Peerless Record Makers will appear at Cumberland, Md., under auspices of the W. F. Frederick Piano Co.

Forman Hamilton, son of W. C. Hamilton, of the S. Hamilton Co., who is an ensign in the United States Navy, is now stationed with the Atlantic fleet in Cuban waters as commander of a submarine chaser. Photographs of the young man reaching his father's desk a few days ago show the lad to be in good spirits and apparently enjoying his life on the sea.

**A. T. EMERSON'S IMPORTANT PLANS**

Head of New Organization with \$1,500,000 Capital Well Known in the Trade

As announced in last month's issue of The World, A. T. Emerson, Inc., is one of the new



A. T. Emerson

entrants in the ranks of talking machine manufacturers. This company, which was recently incorporated for \$1,500,000, will manufacture talking machines on a large scale, and plans are now under way which, when fully devel-

oped, will make the concern an important factor in the industry.

A. T. Emerson, head of this company, is one of the most popular and best known members in the talking machine trade. He is the son of Victor H. Emerson, president of the Emerson Phonograph Co., and has inherited a considerable measure of the remarkable knowledge of the industry which is possessed by V. H. Emerson.

Less than six years ago A. T. Emerson entered the employ of the Pathé Frères Phonograph Co. at a very small salary. His ability was quickly recognized and he was promoted rapidly, eventually becoming general purchasing agent of the company. In this capacity he was in complete charge of all the Pathé cabinet and equipment plants, and under his able guidance the purchasing department of the Pathé factories was established as a model department. His exceptional ability and thorough familiarity with every phase of the business gained for him the respect and esteem of every member of the trade.

As head of A. T. Emerson, Inc., Mr. Emerson will be in a position to utilize to splendid advantage his invaluable experience of the past five years. He is at present visiting the leading trade centers in the interests of his company and within a few weeks will make an important announcement regarding future plans.

The Sturgis Piano Parlor, Sturgis, Mich., has been taken over by E. J. Namey and will in the future be known as Namey's Music Store. The new Edison is carried.

The **SONATA** Phonograph



MODEL G  
ONE OF MANY GOOD STYLES

Stands or falls strictly on its PERFORMANCE FOR YOU.

You dealers KNOW good machines. SALES TALK does not swing you.

**Performance Does**

Let us have a fair chance to prove the

**Sonata Merits**

Listed Sensibly  
Liberal Discounts

We are

*Okch*

Jobbers and furnish you Records promptly and efficiently.

We also Wholesale  
Player Rolls and  
Phonograph  
Accessories

"ALL 'ROUND SERVICE"

**Kennedy-Green Co.**  
1865 Prospect Ave.  
Cleveland, O.

**Phonographs and Show Window Record Stands**

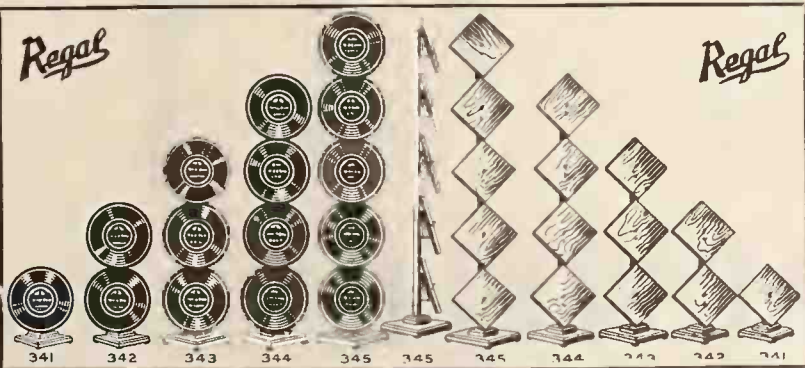

These Show Window Record Stands will increase your Sales on records and help you make attractive window displays. Send for Dealers' Price.

**THE OSCAR ONKEN CO., 6651 4th Street, Cincinnati, O.**





CABINET FACTORY



Hartzell Walnut—  
Standard for 40 Years



Hartzell Mills—  
Known for Efficiency

HARTZELL WALNUT LUMBER MILLS

## Here Is a Real Opportunity to Secure

A SOLID AMERICAN WALNUT PHONOGRAPH that can be sold at a price which will enable you to make a handsome profit and deliver to your customer a product that you can feel *proud of*.

These phonographs are equipped with Heineman motors and tone arms. The cabinets are genuine *Old-fashioned Walnut*. We will give you \$100 for every piece of imitation Walnut you can find in any of our cabinets. The side, back and door panels are 5-ply  $\frac{3}{4}$ " thick with chestnut cores and high quality Walnut face veneer.

### FINISH

We can furnish these cabinets in either a natural walnut or beautiful mahogany finish, using three coats of varnish rubbed down to a smooth egg-shell surface.

### DELIVERY

We can make immediate delivery in either the 50" or 48" model. Please write to us immediately and let us send you our proposition either on completed phonographs or cabinets shipped in carload lots or drop shipments. You cannot afford to *pass up* this exceptional opportunity.



50x22x23



48x19 1/2 x 22

# GEO. W. HARTZELL

PIQUA OHIO



**DEATH OF ERNEST E. ROBINSON**

**Valued Member of Columbia Sales Staff Passes Away—His Loss Regretted by a Host of Friends in the Industry Here and Abroad**

Ernest E. Robinson, one of the members of the export staff of the Columbia Graphophone Co., died on Wednesday, March 31, at his residence in Richmond Hill, L. I. The funeral services were held on April 3 at St. Benedict Joseph's Church, Morris Park, L. I., and were



E. E. Robinson

attended by many members of the Columbia organization.

Mr. Robinson, who was thirty-five years of age at the time of his death, was well known in talking machine circles, having joined the Columbia Graphophone Co.'s staff in 1902, when he occupied a position as clerk in the company's retail store at Eighteenth street and Broadway. He specialized in retail selling and was soon appointed manager of one of the company's branch stores in Brooklyn.

His success in the retail business and his thorough knowledge of the company's extensive catalog attracted the attention of E. N. Burns, vice-president of the company, who at that time was manager of the export department. Mr. Robinson was induced to join the staff of the export department, and started his travels abroad, spending most of his time in the Orient, where he had many friends in and out of the trade.

Mr. Robinson's natural love for music, coupled with his intimate knowledge of public taste, equipped him splendidly for his work. His familiarity with the strange music of the Orient and his acquaintance with various native artists was a material factor in the development of these markets of the Columbia Co. Mr. Robinson had a most attractive personality, and his friends here and abroad will deeply mourn his loss. He is survived by a wife and three children.

**MISS DOROTHY TREMAINE WEDS**

**Daughter of President of Aeolian Co. Becomes Bride of Robert M. Kempton**

Miss Dorothy Tremaine, eldest daughter of H. B. Tremaine, president of the Aeolian Co., was married on March 27 to Robert Morris Kempton, of Philadelphia and New York, at the home of the bride's father in Westfield, N. J. The ceremony was private and unostentatious in character and was attended only by the immediate relatives and close friends of the contracting parties. Mr. Kempton only recently joined the sales organization at Aeolian Hall, New York, as manager of the retail Vocalion department.

To give music its rightful place in the schools where children of the foreigners in our midst are being educated promotes the study of the English language, unity and patriotism.

**NEW "INTERPRETONE" JOBBERS**

**Newton-Elting Distributing Corp. of Trenton to Feature Line Made by Crippen & Co.**

TRENTON, N. J., April 5.—The Newton-Elting Distributing Corp. has been appointed distributor in this territory for the Crippen "Interpretone" phonograph, manufactured by the Crippen Co., New York. The new jobbers have established headquarters at 114 North Broad street and have already instituted an active sales campaign in behalf of the Crippen "Interpretone."

The officers of this organization are Ralph Newton, president; Louis Elting, vice-president and secretary, and Barnett Elting, Sr., treasurer. Mr. Newton was for seven years secretary to the Governor of New Jersey and is well known in civic affairs in this State. Louis Elting conducts a successful retail store in Trenton, and Barnett Elting has been a member of the Trenton business world for more than a quarter of a century. This trio of progressive business men are making plans to give

the Crippen "Interpretone" invaluable representation in this territory, and there is every reason to believe that their efforts will meet with signal success.

**NEW STORE FOR ELMIRA ARMS CO.**

**Handsome Building Constructed Specially for Needs of Talking Machine Trade**

ELMIRA, N. Y., April 5.—The Elmira Arms Co., which handles the Victor line of talking machines and records exclusively, opened its new building last Thursday. This building was specially designed to meet the needs of a talking machine store: stairways and elevators have been eliminated and all departments are on the ground floor. No expense has been spared to make the interior of the new store attractive and well equipped. The building is located at 119 North Main street and is under the direction of Miss Honan.

The Chambers Music Co., New York City, has been dissolved.



**REFLEXO PRODUCTS CO., Inc.**

**MANUFACTURERS OF  
Reflexo Polish  
Reflexo Needles**



Formerly at Marbridge Bldg., New York City



**NEW ADDRESS**

**347**

**FIFTH AVENUE**

**SUITE 1003**

**At 34th Street  
NEW YORK CITY**



THE  
**INDEPENDENT**  
 "SOUL OF HARMONY"



Our  
 Immense  
 Modern  
 Plant at  
 Canton,  
 Pennsylvania,  
 Makes  
 Model Twelves  
 Exclusively  
 at the rate of  
 4000  
 Each Month

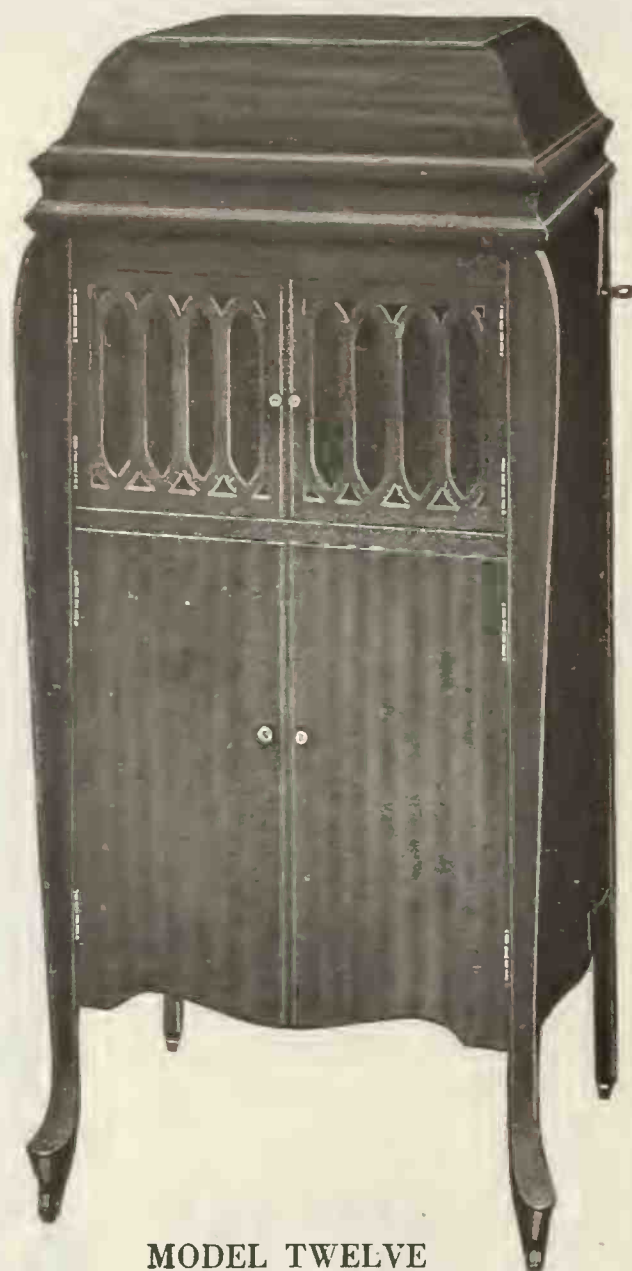

The  
 Largest  
 Best Finished  
 Best Designed  
 Best Constructed  
 Sweetest  
 Toned  
 Talking Machine  
 Offered  
 This year  
 at anywhere near  
 Our Price

**MODEL TWELVE**

Cabinet 46½x20x20½ ins. Genuine Mahogany Panels. Four doors. Heineman 33 Motor. Independent Patent Tone Arm and Sound Box. All Wood Amplifier.

To Retail at \$110.00

Manufactured in its entirety (excepting motors) in our own factories

**DEAL WITH THE MANUFACTURER**

*Write for Discounts*

**INDEPENDENT TALKING MACHINE CO., Inc.**

12 East 42nd St., NEW YORK CITY

SOUTHEASTERN DISTRIBUTORS

Independent Talking Machine Co. of Virginia  
 5 Governor St., Richmond, Va.

NEW ENGLAND BRANCH

105 Washington Street  
 Boston, Mass.



**"Cause of You," by Stracciari, is sure to cause your receipts to swell. Columbia Record 49694.**



**Columbia Graphophone Co.  
NEW YORK**

**BUILDING UP SALES ORGANIZATION**

**Lyraphone Co. of America Now Has Country Well Covered With Distributing Organization—Sales Aids for Dealers—Two Strong Members of Company's Staff**

The Lyraphone Co. of America, Newark, N. J., manufacturer of the well-known Lyric record, has in recent months added considerably to its list of jobbers and dealers in various sections of the United States, until it is now ably represented in all the larger trade centers. The greatly increased demand for this firm's



**J. M. Kohner**



**B. R. Carley**

products has placed the organization upon its mettle in order to deliver records in sufficient quantities to meet the needs of the trade. In addition to increasing the volume of production of the Newark plant, the firm recently announced that it had also acquired a factory in Toronto, Canada, in which production has already started.

Much of the credit of the sales of Lyric records must be given to the sales plans of the company. These are under the direction of Jacques M. Kohner, general manager, and include publicity material of all descriptions for dealers' and jobbers' use. Cut-outs, display cards, hangers, etc., all of attractive design and highly artistic, are issued as a service in heavy quantities. The co-operation given the jobbers is again extended and covers the various sales aids for the dealers, arranged in such a way as to serve the purposes of the individual dealer.

Mr. Kohner, by the way, is a man of long experience in the sales field, having been director of sales for some huge real estate projects in years past. Before joining the Lyraphone organization some two years ago he was connected with some very active record manufacturing concerns. His long experience in the record field places him in a position where he can form plans which at all times have an eye for the dealers' needs. His success in placing the Lyric record in the position which it now holds speaks well for his ability and qualifications as a director of sales.

In making their plans for an immediate increased production, which is to be followed by a steady increase of the number of record presses in the various factories, the firm acquired the services of B. R. Carley, who was recently appointed superintendent of the pressing department. Mr. Carley has had long experience in plastic molding processes and in the handling of technical machinery of all kinds.

He came from England about twelve years ago and for some time was with the Waterbury Button Co., Waterbury, Mass., manufacturers of buttons and phonograph records, etc. He was instrumental in starting the composition department of that firm. This was followed by experience in working on improved methods of molding celluloid, utilizing "steam-jacketed" dyes, and designing presses to replace those of the hydraulic variety. He has carried on much experimental work with some of the leading record manufacturers of the country.

**TO CELEBRATE 50TH ANNIVERSARY**

William Taylor, Son & Co., the prominent department store of Cleveland, O., has planned a ten-day celebration of the fiftieth anniversary of the founding of the business, the celebration to start on April 21. The company conducts a substantial talking machine department, under the management of T. A. Davis, who was recently elected president of the Talking Machine Dealers' Association of Northern Ohio. Victor and Columbia machines and records are handled.

**TO HANDLE LYRIC RECORDS**

The United Music Stores, 1124 Walnut street, Philadelphia, operating a chain of retail stores in that city, have taken the agency for the Lyric records made by the Lyraphone Co. of America. The Stores have long specialized in music rolls, featuring the Connorized line.

**NEW MANAGER IN PITTSBURGH**

**C. R. Parsons Appointed Manager of the Talking Machine Department of the Rosenbaum Co., Prominent Retailers in That City**

PITTSBURGH, PA., April 5.—C. R. Parsons, who is well known in musical circles in Pittsburgh, has been appointed manager of the talking machine department of the Rosenbaum Co. He succeeds P. W. Kline, who was manager for several years and who is now entering the automobile insurance business. Mr. Parsons, who is a native of Colorado, was connected some time with the Columbia recording laboratory in New York. He is a singer of note and is tenor soloist in the choir of the Shadyside Presbyterian Church, one of the fashionable churches of Pittsburgh.

The Rosenbaum Co. handles the Victrola, the Columbia Grafonola and the Pathé phonograph. Its department is one of the most complete in the city. Mr. Parsons has the best wishes of the fraternity in his new line of work.

**INVENTS A NEW DIAPHRAGM**

PHILADELPHIA, PA., April 5.—Patents have been applied for by Alexander McKay, of this city, on a new diaphragm for the talking machine. Mr. McKay has made a study of sound reproduction for the past twenty years and many individual claims are made for this new sound box.



**HENRY BURR**



**ALBERT CAMPBELL**



**JOHN MEYERS**

**PEERLESS RECORD MAKERS**

**In Concert and Entertainment  
Personal Appearance of**

**Eight Popular Favorites on One Program**

**A live attraction for live dealers and jobbers**

Bookings now for season 1920-1921

Sample program and particulars upon request

**P. W. SIMON, Manager**

1604 Broadway

New York City



**BILLY MURRAY**



**FRED VAN EPS**



**FRANK CROXTON**



**MONROE SILVER**



**FRANK BANTA**

Famous Ensembles including

**Campbell & Burr - Sterling Trio - Peerless Quartet**



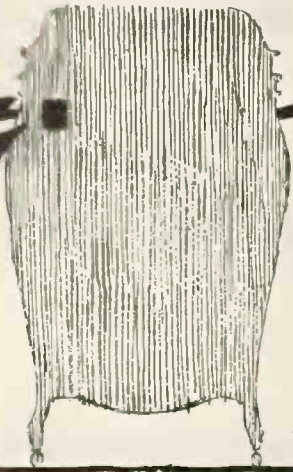

This tiny motor, which you can literally hold in your hand, stabilizes the vast power available to it and has finally solved the problem of unvarying speed on the phonograph turntable.

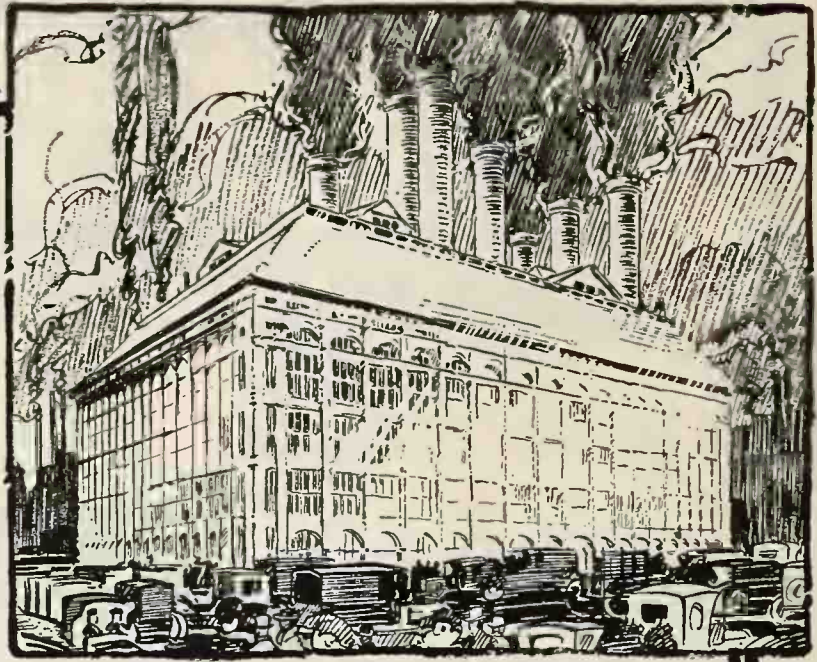

# Controlled!

Night and day, whether the load on the wires be at low or peak, an absolutely constant speed is maintained by the

## EFFICIENCY ELECTRIC PHONOGRAPH DRIVE

(FULLY PROTECTED BY PATENTS PENDING)

**T**HE ultimate quality in phonograph motors has thus been achieved. The Efficiency Electric Phonograph Drive is guaranteed to maintain constant turn-table speed on 110 volt Alternating Current, 60 cycles and under, on 110 volt Direct Current and through every variation in voltage on commercial lighting circuits.

The Efficiency Drive is enclosed in a dust-proof case and sealed.

The Efficiency Drive is further guaranteed to run without heating

up, to operate in silence, to produce perfect tone at the exact speed intended for the record, to need no adjustment, oiling or attention for at least two years and to function satisfactorily under every condition of proper usage if the seal of the motor remains unbroken.

Deliveries may be depended upon in accordance with any agreement that we make.

Send to-day for complete particulars.

### STANDARD EQUIPMENT

Manufacturers, dealers and users of talking machines have long demanded the perfect self-starting talking machine and to fill this demand manufacturers can safely install the Efficiency Electric Drive as their standard equipment.

## EFFICIENCY ELECTRIC CORPORATION

*Factory:*  
LOWELL, MASS.

*Experimental  
Laboratories:*  
124 WHITE STREET  
NEW YORK





## IMPORTANT EDISON SALES CONFERENCES DURING MARCH

Dealers, Jobbers and Travelers Hold Meetings in Various Sections of the Country and Enthusiastically Endorse Proposed Campaign for Increasing Business During 1920

The Edison sales promotion plans, known in the Edison trade as "The Fourteen Points," which were presented in elaborate form to the jobbers on March 1, have aroused enormous enthusiasm on the part of the dealers to whom the various plans have been explained. The Edison laboratories are making no public announcement of these plans, but are leaving it to the jobbers' salesmen to explain the various propositions to the dealers on whom they call.

Several of the Edison jobbers have held recent conferences with their dealers, and other meetings are to occur during April. L. H. Lucker will have a two days' convention at Minneapolis on April 20 and 21. The Edison jobbers on the Pacific Coast and in the Rocky Mountain district will meet at Ogden, Utah, during the week of April 26. April will probably wind up these preliminary conventions.

The Edison Caravan Convention will start out early in July. The exact itinerary of the Caravan Convention has not yet been determined, but it is expected that New York, Chicago and San Francisco will be among the stopping places.

Reports of the meetings of jobbers, travelers and dealers in Kansas City, St. Louis, Minneapolis and other cities appear on other pages of *The World* this month. Among other conventions, however, was the meeting of dealers in Albany under the auspices of the American Phonograph Co., Edison jobbers in that city, with practically every dealer in the territory present at the sessions at the Hotel Ten Eyck. Peter R. Hawley, traveler for the jobber, presided. An exceptional talk on Edison window displays was made by D. P. Babcock, manager of the dealers' service department for the Edison Co., and E. Trautwein, of the Edison Co., thoroughly discussed "Sales Aid Service." Frank Jewel Raymond, of East Orange, a lec-

turer on salesmanship, gave a "pep" talk on the importance of tidiness and store arrangement and display, courtesy on the part of the employees and unremitting attention to the obligations which real service to customers means. The entire afternoon was devoted to a discussion of the various 1920 sales plans, following a presentation of the plans by Mr. Leonard. The dealers were tremendously enthused and several announced their intention of subscribing to the service before the meeting adjourned.

### Jobbers Confer at Atlanta

On March 12 and 13 a jobbers' regional conference was held at Atlanta. Mr. Leonard represented the Edison laboratories. Jobbers and jobbers' representatives who were present were: W. L. F. Rosenblatt, W. B. Word, J. F. Tolle-son and A. C. Wetherington, of Phonographs, Inc., Atlanta; A. T. Donnelly, A. Schreiber, J. W. Stromberg, Justin E. Farrand and G. Russell Hardy, of the Diamond Music Co., Inc., New Orleans; P. H. Oelman, T. P. Bassett and Sales Promotion Manager Smith, of The Phonograph Co., Cincinnati; E. Bowman and F. R. Dapprich, of C. B. Haynes Co., Inc., Richmond.

Mr. Rosenblatt acted as chairman of the convention and L. G. McClair, of Phonographs, Inc., Atlanta, was secretary. Practically all of the two-day conference was devoted to the discussion of the new sales promotion plans and methods of handling them at the jobber's end with maximum efficiency and dispatch.

### Richmond Has First Convention

On March 15 Mr. Leonard attended the first dealers' convention of the C. B. Haynes Co., Inc., at Richmond. This meeting was hurriedly called when Mr. Haynes learned that Mr. Leonard was going to Atlanta and could arrange to stop off at Richmond on the way back. A good number of the dealers in the Richmond territory were present. Those at-

tending were exceedingly enthusiastic over the new sales plans and the bright outlook for the future. Following the meeting, Mr. Haynes was host at the luncheon to the dealers given at the Hotel Jefferson.

### Eastern Jobbers' Conference

Jobbers and their representatives from Boston, Philadelphia, New Haven, New York, Syracuse, St. John's, Canada, Albany, Williamsport, Toronto and Pittsburgh zones convened at the Hotel Biltmore, New York City, on Monday, March 15. E. C. Boykin, the New York jobber, presided over the meeting. The Edison laboratories were represented by John J. Shearman, assistant general sales manager; H. R. Skelton, territorial supervisor; J. B. Gregg, advertising manager; D. E. Wheeler, editorial director, and Roy T. Burke, editor of Edison publications.

The new sales promotion plans were thoroughly discussed by Mr. Shearman, and his explanations were met with marked approval by the jobbers and their travelers; W. O. Pardee, of Pardee-Allenberger Co., New Haven, gave a talk on how a jobber should back up his travelers in putting over these new plans. Mr. Pardee explained that a spirit of co-operation and a bond of sympathy should at all times exist between the house and the jobber's salesman. He showed that the service which the jobber accords his dealer, even to the smallest details, is one of the strongest acts of backing a salesman can have. Peter R. Hawley, of the American Phonograph Co., Albany, devoted a few minutes to a discussion of "The Over the Top Contest." J. B. Gregg, advertising manager of Thomas A. Edison, Inc., explained "How the Advertising Department Will Tie Up With the New Sales Plans." Mr. Boykin spoke on "A Few Thoughts on New Ideas." F. E. Bolway followed with a talk on "Quotas." He said that it was his opinion that a business without quotas was quite similar to a life without a worthy ambition. He said that from his experience he had found that the idea of

(Continued on page 177)

# STODART

PHONOGRAPH

*The sign of a quality phonograph*

Made by the makers of one of America's oldest pianos  
Unexcelled for Beauty of Case Design, Tone and Equipment

Style AA



Five handsome models in mahogany veneer, covers and cover mouldings solid mahogany.

Stephenson Precision-made motor with velour turntable. Universal Tone Arm.

A wonderful reproducing device, furnishing beautiful tone in great volume—Tone modifying rod.

The Stodart Phonograph is famous for quality  
which cannot be surpassed

Get details of our proposition and *make money*  
with this leader

## STODART PHONOGRAPH CO., Inc.

GEORGE H. BEVERLY, *General Manager*

119 West 42nd Street

NEW YORK

Style C





# TRIANGLE TONE ARM and SOUND BOX No. 2

*"The scientifically perfect sound reproducing combination"*

A fold-back arm for the critical manufacturer.

A high-grade arm that is pleasing to both the eye and ear.

An outfit that will please the most exacting. It transforms any phonograph into a real musical instrument.

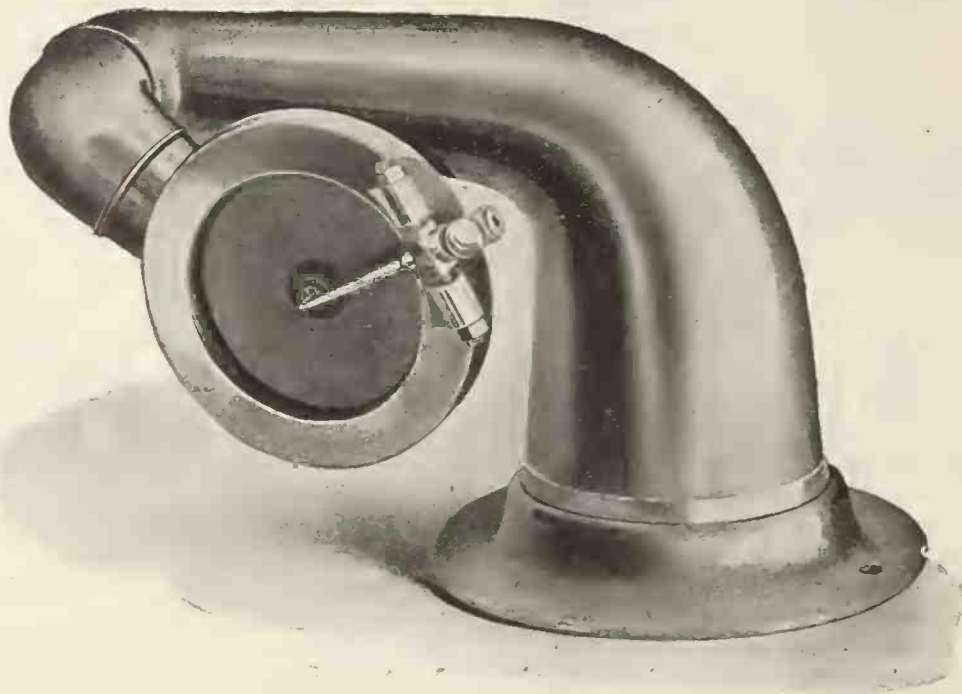

Harsh and metallic sounds so common to the average arm and box are entirely eliminated.

The Triangle Combination produces a mellow musical tone that delights the finished musician.

Only a trial can adequately prove to you the sterling quality of this tone arm and sound box. It is a marvel of beauty, with a surprising and wonderful tone as clear as a bell. Every detail of the record is brought out in a marvelous manner.

The Triangle Combination is guaranteed to play perfectly and without any blast the most difficult of any records made, a fault found in 99% of the arms and boxes made today.

Manufactured in two sizes, 8 $\frac{1}{4}$ " and 9". Diameter of base, 3 $\frac{1}{2}$ ", Opening in base, 1 $\frac{7}{8}$ ", Height over all, 3 $\frac{3}{4}$ ". Finished in nickel and satin gold.

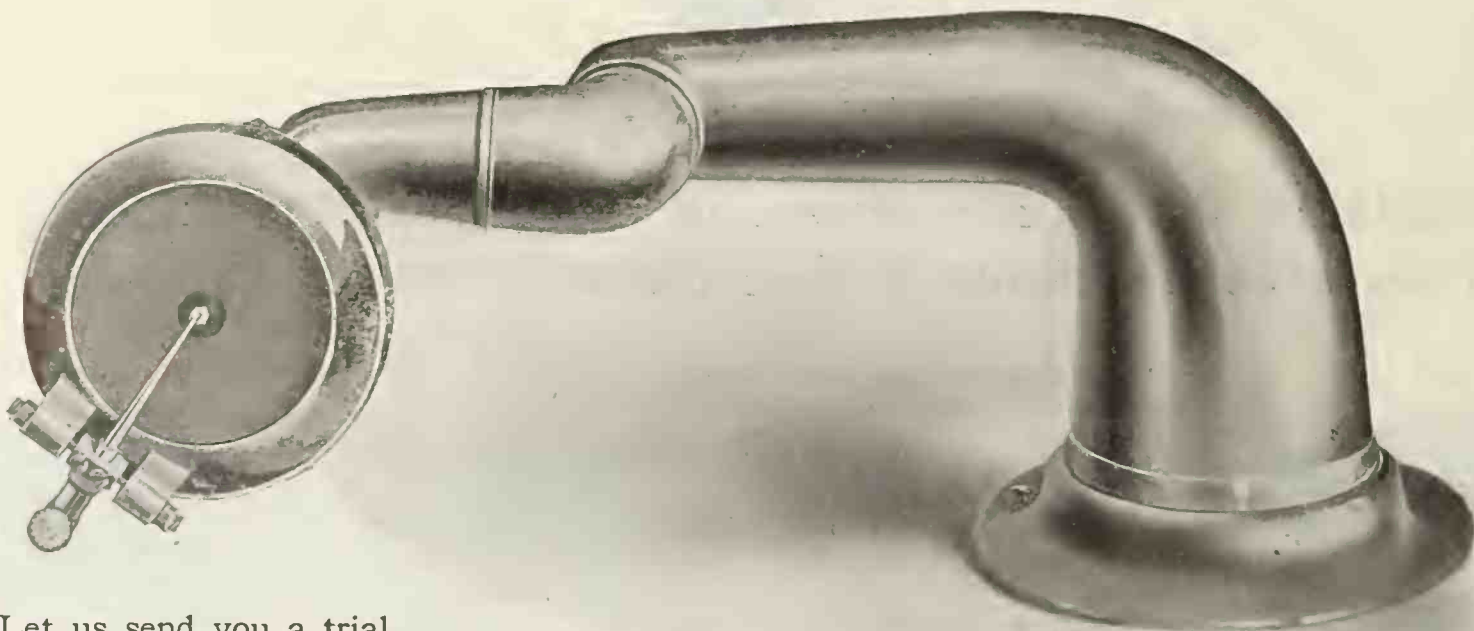

Let us send you a trial sample *at our expense* for demonstration.

MANUFACTURED BY

## TRIANGLE PHONO PARTS CO.

722 ATLANTIC AVENUE

--

--

--

BROOKLYN, N. Y.



**EDISON SALES PROMOTION PLANS**  
*(Continued from page 175)*

having quotas for business attainment makes all business men far sighted ones, because it causes them to look ahead a year and plan for a year ahead. Mr. Boykin was host at a dinner given at noon to the convention in the Hotel Biltmore. The afternoon was given to a general discussion of the new sales plans. A marked spirit of optimism was present at the conference.

Besides those heretofore mentioned, others present at the New York meeting were: F. H. Silliman, L. H. Ripley, G. R. Coner, F. S. Boyd and T. E. Dean, of the Pardee-Ellenberger Co., Boston; R. C. Cope, W. C. Stiver, Jas. Robinson and Harvey Trader, of the Girard Phonograph Co., Philadelphia; W. A. Myers, of Williamsport; Albert A. Buehn, Edw. W. Voss, J. K. Nichol and Edw. J. Condon, of the Buehn Phonograph Co., Pittsburgh; J. T. Keeney, F. L. Stoddard and C. H. De Forest, of the Pardee-Ellenberger Co., New Haven; N. D. Griffin, of the American Phonograph Co., Albany; J. G. Brown, C. L. Eddy, H. G. Emmons and H. C. Bush, of Frank E. Bolway & Son, Inc., Syracuse; J. W. Andrews, of W. H. Thorne & Co., Ltd., St. John, N. B.; T. A. Dillon and O. Wagner, of the R. S. Williams & Sons Co., Ltd., Toronto; J. B. Gowdey and A. W. Toennies, of the Phonograph Corp. of Manhattan.

**MISS GOLDSMITH VISITS CUBA**

Manager of Export Department of Aeolian Co. on Flying Trip to Havana

Miss Lucy Goldsmith, manager of the export department of the Aeolian Co., left on a short trip to Cuba last month in connection with business matters. She intended to return to New York by April 15 in order to confer with the Aeolian Co. representatives coming from Australia and other points.

**UTILIZATION OF CHIMES AND BELLS IN RECORD MAKING**

An Interesting Article on the Use of Chime Effects in Connection with Certain Victor Records —How They Have Been Adapted Successfully for Orchestra Accompaniment

The current issue of The Voice of the Victor, among other live matters, contains the following thoroughly interesting discussion of the use of chimes and bells in adding to the effectiveness of certain Victor records, together with something of the adaptation of chimes for orchestra accompaniments. The article says, in part:

The initiative and imagination shown by the Victor musicians in devising new orchestral effect or readapting old ones to Victor needs is marked in nothing so much as the increasing use of chimes in our record orchestra accompaniments. The chimes are a new arrival in the theatre orchestra, and while freely used in musical comedies and vaudeville orchestras, it has been left to the Victor Orchestra to develop their use to a fine art.

Composers have always been anxious to use bells in the orchestra, but the ordinary bell is not at all suited for this purpose. A bell is very rich in overtones (sounds additional to the fundamental note), and anyone who has lived in a European city where the church bells are loud enough to dominate the country for miles around knows how hard it would be to combine their variegated sound with the harmonies of the orchestra without one or the other seeming out of tune. As far back as Mozart efforts were made in this direction. Mozart used musical glasses in "The Magic Flute" by means of a system perfected by our own Franklin.

In more recent times the "Glockenspiel" has supplied the orchestra with chime effects. This consists of tubular bells adapted to orchestral needs. The tubes are hung in suspension and struck with a hammer wielded by a performer, usually the orchestral drummer. Their use in serious music is necessarily limited. Wagner used special forms of bells to sound ponderous tones in "Parsifal," but this is exceptional.

The Victor chimes are something decidedly unique. They are of delicious quality, of bell-like character, but without the harshness and clangor peculiar to true bell tone (and part of its charms when appropriately used out of doors in a cathedral town on a festival occasion). The function of the chimes is mainly decorative. Tunes can be, and have been, played on chimes alone and satisfactorily recorded by the Victor. Heard alone, however, their scope is limited. As part of the accompaniment, on the other hand, they can be used with ravishing effect. Sometimes a single bell note, heard unexpectedly, gives character to the entire record.

They are particularly valuable, of course, in the accompaniment of the many songs we have about weddings, but they are useful in almost any music where a dreamy effect is wanted.

To the salesman the chimes are a valuable sales aid. He has but to remark to a customer before playing a record with a chime note in it, "Listen for the bell," to ensure the customer's closest attention to the record. For some inexplicable reason all of us love to be given something definite to listen for in a piece of music, and are delighted when the long-awaited sound suddenly appears. This is a most valuable human tendency for the Victor salesman who wants to concentrate his customer's attention on a record. The chimes are particularly well suited to this purpose, because nobody can miss hearing a bell note—it is so distinctive. Those who have been trained to listen for chimes can well be trained to listen for less obvious things and the way is open for the salesman to perfect himself in musical observation so that he can find other points besides bells by which to draw his customer's attention.

**"Easier to sell**  
**than any other**  
**phonograph in the world"**

That's the way salesmen talk about

The **Aeolian-VOCALION**

*The new and greater phonograph*

**VOCALION RECORDS** Two distinct styles of records. A lateral cut and a hill and dale. You can therefore sell EVERY phonograph owner in your community.

— Ask for our Dealers' Proposition —  
We are Western Distributors, prepared to give you the goods you want WHEN YOU WANT THEM.



13 to 19 East 1st, South - - - - - Salt Lake, Utah

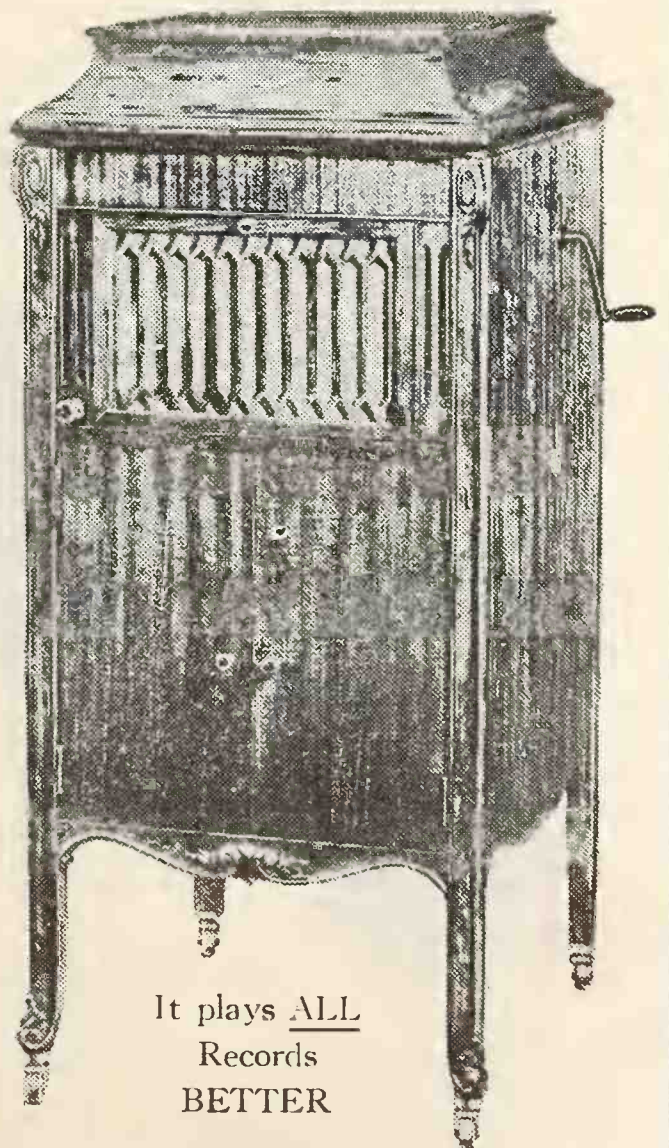

It plays ALL  
Records  
BETTER





Manufacturers



**SALES POINTS OF THE EXCEL**

Tone Quality—Artistic Cabinet Designs and Exclusive Features Make Sales. The EXCEL embodies all of these dominant qualities.

The Motors, Reproducer and other equipment make the SALES STICK. The EXCEL equipment is the highest grade the market affords.

DELIVERIES at all times in ample QUANTITIES are next in IMPOR-

TANCE. Our three factories centrally located GUARANTEE you both.

Note our offer: We will ship you one or more of the EXCEL MACHINES on APPROVAL. If satisfactory you will honor invoice at maturity. If not you return the machine AT OUR EXPENSE. HAVE YOU EVER RECEIVED A BETTER OFFER? Take advantage of it and become an EXCEL dealer by writing AT ONCE.

**EXCEL CABINET CO.**

Executive Offices: 136-140 West 23rd Street New York City

Factories: Benton Harbor, Mich.; Holland, Mich.; Chicago



Manufacturers of  
High Grade  
Talking  
Machines





**GREAT GATHERING OF COLUMBIA DEALERS IN MILWAUKEE**

Big Campaign of Sales Promotion Started at Meeting of 150 Columbia Dealers at Hotel Wisconsin on April 1—Kenneth Mills and S. Sebok, of Chicago Headquarters, Make Addresses

MILWAUKEE, Wis., April 5.—The opening gun in a big campaign of sales promotion in behalf of the Columbia Grafonola and Columbia records was fired Thursday evening, April 1, when the Columbia Graphophone Co. entertained nearly 150 Columbia dealers and invited guests at a banquet in the gold room of the Hotel Wisconsin, which was followed by a merchandising conference. The affair was in charge of Robert H. Walley, a widely known Columbia man, who is now resident representative of the Chicago

bia machines and records in this territory. Following a delectable five-course dinner, Mr. Walley as toastmaster introduced Kenneth Mills, manager of the Chicago branch house, who outlined the Columbia merchandising plan for 1920. S. Sebok, in charge of the foreign language record division at Chicago, talked on plans for an intensive campaign for the promotion of foreign record sales in Milwaukee and eastern Wisconsin, which contain a large foreign-born population. Miss Genevieve Quealy, special New



Columbia Co. Entertains 150 Dealers and Guests in Gold Room of Hotel Wisconsin, Milwaukee branch in Milwaukee, with territory embracing all of eastern Wisconsin.

The attendance showed a 100 per cent representation of Columbia dealers in Mr. Walley's territory. Not only were the dealers invited, but they were urged to bring with them their wives and their salespeople. The most extensive Columbia dealers, such as A. G. Kunde, 516 Grand avenue; C. W. Fischer Furniture Co., 207-215 Second street; Waldheim's, 210-214 West Water street, and the Bloch-Daneman Co., 282-284 West Water street, were fully represented, besides many other stores handling the Colum-

bia machines and records in this territory. Following a delectable five-course dinner, Mr. Walley as toastmaster introduced Kenneth Mills, manager of the Chicago branch house, who outlined the Columbia merchandising plan for 1920. S. Sebok, in charge of the foreign language record division at Chicago, talked on plans for an intensive campaign for the promotion of foreign record sales in Milwaukee and eastern Wisconsin, which contain a large foreign-born population. Miss Genevieve Quealy, special New York representative of the educational department, who is now working out of the Chicago branch, told of the work which the Columbia is doing in the public schools. Other speakers were J. Kapp, in charge of the English record division at the Chicago branch, and M. B. Smith, assistant manager of the Chicago branch, who reported on advertising and publicity work for 1920 in co-operation with its dealers.

A practical demonstration of selling records was given with Mr. Kapp as the salesman and Miss Quealy the customer. Mr. Kapp afterward went through a second demonstration with Miss

Gladys Kimmel, of Waldheim's, taking the part of the customer.

Miss Helen Gunnis, a noted soprano, who is manager of the phonograph department of the C. W. Fischer Furniture Co., rendered "Say It With Flowers" to the accompaniment of the Columbia record of the composition. This served to give opportunity for the explanation by Mr. Walley of the courtesy of the Milwaukee Florists' Association in sending to the banquet an exquisite floral piece which decorated one end of the banquet hall and served as the background for a Columbia Grafonola. The floral gift was an appreciation of the florists for the Columbia company's creation and promotion of the "Say It With Flowers" record. A Kittelman, 1819 Center street, exclusively Columbia dealer, also contributed a beautiful floral piece.

The movement of topical records that may become out-of-date over night was a subject of considerable discussion and explanation, Mr. Kapp and others using as an example the Columbia record, "Look What My Boy Got in France." The result was that in the days following the banquet Columbia dealers here succeeded in moving practically every one of these records in stock.

After the conference five vaudeville acts imported from Chicago by Leo Feist, Inc., for the occasion, delighted the crowd for two hours. The gathering ended with dancing to Columbia dance records.

**RECORDING FOR THE VOCALION**

Among the latest additions to the list of artists who are recording for Aeolian-Vocalion records are the Kouns Sisters, Nellie and Sarah, who have recently won success in the leading roles in the "Frvolities of 1919." The Kouns Sisters have already recorded several numbers for the Vocalion, including "Annie Laurie," Carrie Jacobs-Bond's "Just a-Wearyin' for You," "The Kiss," and "Sing, Smile and Slumber," by Gounod. The sisters have arranged to record other numbers before leaving for England.

*Just What You Have Been Waiting For*

**The GATELY Carrying Case**

for VICTROLA VI's

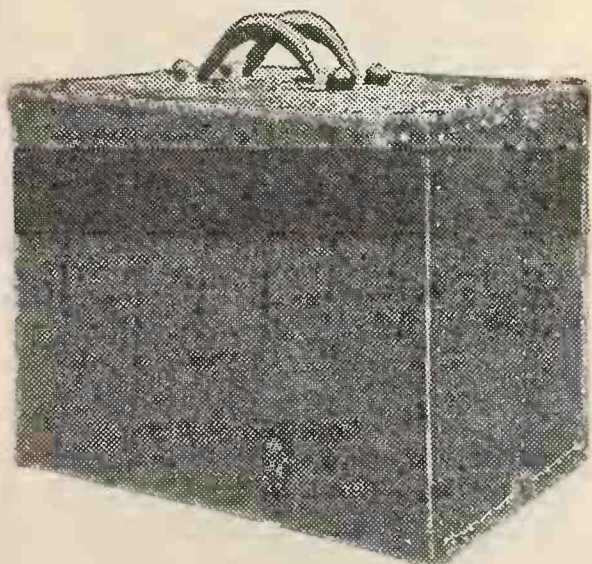

This handsome carrying case will help increase your VICTROLA VI sales.

The Gately Carrying Case is constructed of wood, covered with black waterproof fibre and substantially made so that it can be carried by one man or as baggage.

Each case is arranged to hold thirty 10-in. or 12-in. records, and has a separate place for a sound box, winding key and needles.

**Price, \$8.50 Wholesale**

*Write for Descriptive Circulars*

**GATELY-HAIRE CO., Inc. - - Albany, N. Y.**



PERMANENT EXHIBITION, BUSH TERMINAL BUILDING, NEW YORK



Style No. 95

Height 45 in., Width 19 in., Depth 21 in.  
Mahogany, Fumed or Golden Oak  
Finish. Equipped with "Krasco"  
Motor. Universal Tone Arm.

## Quality Phonographs For Less Money

There is no guess-work about the value of Operollo phonographs. Our permanent policy is concentration on quality instruments.

We are proud of our achievements for we are turning out a high grade instrument at a popular price.

Operollo phonographs are the best moderate-priced machines on the market to-day.

They give everlasting service and have met with a remarkable success. Dealers find they sell easily and have built up a large phonograph business with them.

Every Operollo Phonograph is sold under a positive guarantee.



## Lyric Records

Every phonograph dealer requires records, and here is additional profit for you.

We are distributors of **Lyric Records**. They appeal because of their wonderful natural tone and musical quality.

**Record service** insures 100% business to every phonograph dealer.

**Liberal Discounts assured. Secure sample line at once.**

The large demand for Lyric Records may soon compel us to limit our record supply to Operollo Dealers only.

*Write to-day for attractive agency proposition*



Style No. 135

Height 50 in., Depth 23 in., Width 21 in.  
Mahogany, Golden and Fumed Oak.  
"Krasco" Motor. Universal Tone  
Arm. All Wood Amplifier.

# OPEROLLO PHONOGRAPH COMPANY

54 W. LAFAYETTE BOULEVARD

DETROIT, MICH.



## PROSPERITY CONTINUES IN MINNEAPOLIS TRADE

Dealers and Jobbers Optimistic Over General Outlook—Larger Shipments Arriving—Beckwith & O'Neill Alterations Under Way—Stone Piano Co. Booming Vocalion—News of Month

MINNEAPOLIS and ST. PAUL, MINN., April 5.—Notwithstanding that Spring has appeared in the Northwest and the birds are out with their vernal music, the talking machines continue to sing right merrily—for the public and for the dealers. Truly, it is a good thing to be a talking machine dealer in the Northwest in 1920, for the facilities for obtaining and maintaining a fairly complete stock are much better than they have been at any time since early in 1917. Dealers say that they can see nothing either above or below the horizon to disturb their serenity, as the talking machine still continues to ride on the crest of public favor.

At the present rate of shipments, Laurence H. Lucker, Edison jobber, says that he should be all caught up on 1919 orders by July. That it will be possible to accumulate any general stock is not in his expectations, but he hopes that it will be possible to fill orders for 1920 with greater celerity and completeness than has been possible in the past three years. The house made its monthly record for shipments in March, which month ordinarily is the lightest of the year. The record was made possible by the filling of back orders in connection with large new ones. Mr. Lucker is especially pleased with the excellent success of the factory people in supplying records. The latter are coming through in large quantities and waiting lists are rapidly being written off the books.

All the Edison people are much interested in the coming appearance of Anna Case at the Minneapolis Apollo Club concert April 20, for they want to see and hear that Edison artist in person.

Things also look better for the Brunswick interests, according to E. L. Kern, Northwestern director for the Brunswick-Balke-Collender Co. The receipts from the factory are reported to be large and steady and enable Mr. Kern to accommodate his long-suffering but patient patrons.

"Our machines are coming in right nicely in comparison with the past," said Mr. Kern. "In fact, the situation is so greatly improved and the factory management gives such fine assurances that I have been getting ready to open some new accounts. I can't do it right away, but look for a favorable opportunity soon. We have a long waiting list of candidates for Brunswick agencies and the majority are entitled to consideration as soon as we can get the goods." George M. Nyew, Brunswick phonograph traveler, came in last week after a long road trip.

As usual, there is only one complaint against the Victor machines—there are not enough to go around, although the situation is improving

# P-A-P-E-R

We specialize on the paper requirements for talking machine manufacturers and dealers. Our experience will help you solve your paper problems.

Record Pockets and Delivery Envelopes carried in stock.

---

## H. G. NEU & COMPANY

108 Worth Street, New York 2049 Franklin

steadily, and George A. Mairs, head of the W. J. Dyer & Bro.'s Victor department, is sanguine that the Victrola millennium may be near. There is still no question, he says, of attempting to satisfy the long list of applicants for appointment as Victor dealers, as the current supply will not even go around among the old dealers, but the latter are being taken care of more generously than a year ago.

The Dyer Victrola department lost a big plate glass window in a baby hurricane a fortnight ago and was for some days concealed behind an ugly board wall, but is now looking almost as good as new. It was necessary to divide the window as the old pane was of such exceptional size that it could not be replaced at present.

A monster board wall, five stories high, now covers the building which is to house the Victor department of the Beckwith-O'Neill Co., Northwestern distributors. Behind the wall a large force of men is at work tearing out the entire front and making a new one. The remodeling work will cost between \$25,000 and \$30,000. Possibly the building may be ready for occupancy in the latter part of June.

Archie Matheis and his wife have returned from their long sojourn in the sunny Southland and he is prepared to resume management of the Talking Machine Co.

With the receipt of a goodly supply of large-sized Pathé phonographs, Jay H. Wheeler, department manager for G. Sommers & Co.,

Pathé distributors, would be quite content. He acknowledges that he is getting together a fine stock of instruments and records and that the roadmen are making excellent returns. All he needs is a greater number of big machines.

An advance in Sonora prices has been announced by Sewell D. Andrews, of the Minneapolis Drug Co., which distributes these instruments. The Sonora instruments have been going very nicely in this section.

An aggressive campaign for business has been inaugurated by the Stone Piano Co. for its Aeolian-Vocalion department. Manager Gerlach states that several men have been put on the road to spread the gospel of the Vocalion and he is confident that with the aid of the extensive advertising campaign conducted by the Aeolian headquarters excellent results will be obtained. He feels justified in going the limit, so to speak, as assurances have been given that there will be no lack of instruments, such as has handicapped him for the past six months.

The Edison dealers of the Northwest will meet April 20-21 at the Hotel Radisson to talk shop. Among the features of the musical program will be the Fleming Trio.

Announcement was made this month that the firm of Baim Bros. & Friedberg, Brooklyn, N. Y., which does a large business in talking machines, records and accessories, has arranged an increase in capital stock of the company from \$60,000 to \$130,000.



Model No. 3. Retail \$45.00

## CHARMAPHONE TABLE MODEL

"THE UNIVERSAL PHONOGRAPH"

This handsomely constructed table machine, equipped with the famous smooth running noiseless double spring Heineman No. 36 motor and the universal Charmaphone tone arm and sound box.

*Write for Illustrated Catalog—Now*

## CHARMAPHONE COMPANY

39-41 West 32nd Street, New York

**SEE OUR FULL PAGE AD—PAGE 33**



# How I Sell Records

"I've been selling records for a good many years and my business has increased steadily. But I never could start a *real boom* because I had nothing special to offer that my competitors couldn't also offer.

"But now I've got something **REALLY NEW**. I sell Grey Gull Records, Two-In-One Style, and every one of my customers gets twice more music on every record than he ever got before, at no advance in price. This is the kind of selling point that doesn't need any arguing or explaining. My business is growing rapidly because everybody that wants this 'queer new record that plays so long' has got to come right to **ME** for it."—*A Dealer.*

---

Grey Gull Records, Two-In-One Style, give from 4½ to 5½ minutes of **REAL MUSIC** on every ten inch disc—approximately twice as much as the old-fashioned kind. We often put four complete pieces on the two sides of one record—and ask no more than for records that give only half as much value.

No other record can give you this long-playing feature. It is made possible by an invention owned exclusively by us on which a patent is now pending.



INCORPORATED

295 HUNTINGTON AVE., BOSTON

FILL OUT COUPON AND MAIL

GREY GULL RECORDS, 295 Huntington Ave., Boston, Mass.

Please send to address below, an easy-selling assortment of eight Grey Gull Records, for which remittance of \$5.00 is enclosed. Privilege of returning these records within ten days, at your expense, and obtaining a refund of the remittance is reserved. Also send your two leaflets, "Distributor Proposition" and "Dealer Proposition," and list of your records.

Name \_\_\_\_\_

Address \_\_\_\_\_



**BIG EXPANSION PLANS PERFECTED BY THE EMERSON CO.**

Plants Which Will Insure a Tremendous Increase in Record Output Being Completed in Long Island City and Framingham, Mass.—Plant Being Erected in Chicago—Scranton Factory Busy

H. T. Leeming, vice-president and general manager of the Emerson Phonograph Co., New York, announced this week that the company has completed a series of important deals which are of exceptional import and significance.

With the consummation of these arrangements, the company's record output will be augmented tremendously, for at the present time a large factory is being constructed in Long Island City, which, when completed, will have a daily output of 30,000 to 40,000 Emerson records. Another large plant is now being erected in Framingham, Mass., and when this factory is completed it will provide for an output of 50,000 records daily.

Recently arrangements were made for the erection of a large plant in Chicago, which will have an output of 30,000 records daily. Mr. Leeming also states that with the closing of important deals now pending, the company will have factories on the Pacific Coast and in the South.

Aside from all of these new plants, the Scranton factory of the Emerson Phonograph Co. is working to capacity with a day and night shift. This plant, however, has been unable to keep pace with the tremendous demand of Emerson records, and the new buildings will afford the company an opportunity to co-operate efficiently with its jobbers and dealers.

A short while ago Mr. Leeming in a message to the trade emphasized the desirability of erecting record factories adjacent to centers of distribution. He pointed out the many manufacturing and shipping advantages afforded by the location of factories in the centers of trade channels, and in accordance with these ideas, started negotiations for the construction of modern and up-to-date record plants. These negotiations have now materialized, and when the new factories are in full blast the Emerson

Phonograph Co. will have one of the most efficient manufacturing organizations in the industry.

During the past year and a half the success of the Emerson record has been little short of phenomenal. The company's sales have increased by leaps and bounds, until about six months ago the matter of production became a



H. T. Leeming

most serious element in the company's future plans. Mr. Leeming, who is one of the best known members of the industry, immediately recognized the importance of bringing the production of Emerson records closer to the country-wide demand, and under his direction every effort was made to increase the output of the Scranton plant.

These efforts were very successful, but the

demand for Emerson records advanced so rapidly in recent months that additional factory facilities were absolutely imperative. Mr. Leeming, assisted by the members of his executive staff, is devoting a considerable portion of his time to the speedy completion of the new factories, and Emerson jobbers and dealers will welcome the news that the output of these records will be vastly increased within a very short time.

**ACME PHONOGRAPH CORP. EXPANDS**

Acquire Motor Factory at 243 West Seventeenth Street, New York—Offices Located Here Also—Plant Equipped to Meet Business Growth

The Acme Phonograph Corp. of New York City is expanding rapidly. During the first week of the month it acquired a large and well equipped modern talking machine motor factory as well as a plating works at 243 West Seventeenth street. This new plant occupies an entire floor in a large loft building and there is an adjacent floor that will allow for further expansion. The Acme Phonograph Corp. will move its offices to this new address and it has already efficiently rearranged the production plans of this factory to allow for an immediate large increase of production. A large supply of raw materials has been contracted for, which will eliminate all delay in this direction. The Acme motor is the culmination of much experimentation and many high claims are made for it. The motor will be made in three standard types and two springs only. The Acme tone arm will also be produced in this new factory, as will the Acme sound box. A patented tone modifier within the tone arm itself is a feature of the Acme tone arm. This new factory is the fourth to be added to the manufacturing resources of this firm. Two other factories are already working to capacity at Boonton, N. J., and the third is still under construction in this same town. By co-ordinating all these facilities greatly increased production will result.

**REAL MERIT WINS**

HIGHEST QUALITY MOTORS  
Universal Tone Arms



RECORDIONS make friends easily by their wonderful tone and stay sold on account of the unchallenged quality.

THE *Recordion* HAS IT  
TRADE MARK  
REG. U.S. PAT. OFF.

PLAYS ALL RECORDS PERFECTLY



RECORDIONS are selling fast. We have but recently enlarged our factory floor space and shall do so again. There's a Good Reason.

**OUR MOTOR TRUCK DELIVERY**

is QUICK and SAFE and has many other advantages. We therefore especially invite Dealers from GREATER NEW YORK and adjacent territories to write for the Latest Booklet and Prices or to call and see the

**1920 MODELS now on Exhibition**

at the newly-renovated office of the

**Columbia Mantel Co., Inc.**  
Leonard and Devoe Sts., Brooklyn, N. Y.

Within walking Distance from Williamsburg Bridge Plaza

**BE A LIVE WIRE—BE THE FIRST RECORDION DEALER IN YOUR VICINITY**





## Back Again—

to bring the joy of music into hundreds of thousands of homes comes the sensational Stewart Phonograph---now improved and refined at many points.

War conditions which interrupted production in 1918 no longer prevail. Today, output and sales are reaching tremendous proportions.

Write today for full particulars about one of the quickest selling propositions in the world.

# Stewart PHONOGRAPH

STEWART PHONOGRAPH CORPORATION, Inc.

LINCOLN BUILDING

--

--

--

--

BUFFALO, N. Y.



### PUBLICITY AND MERCHANDISING CO-OPERATION PLANS

Columbia Graphophone Co. Has Worked Out Many Stimulative Sales Helps Which Will Greatly Assist Its Dealers in Developing a Larger Volume of Summer Business—Interesting Details

In accordance with its custom of previous years, the Columbia Graphophone Co. has prepared for the use of its dealers during the Summer months an elaborate plan of publicity and merchandising co-operation which can be used to excellent advantage. The details of this plan have been worked out carefully by the company's Dealer Service department and are now ready for presentation to the trade. Many of the ideas advanced for the use of the dealers during the Summer months are brand new, and embody practical, stimulative sales helps which will undoubtedly assist the dealers materially in making their Summer business during 1920 exceed previous years.

In a recent chat with The World, C. Shaw, of the Dealer Service department of the Columbia Graphophone Co., outlined some of the company's sales plans as follows:

"One of the principal sales aids for our dealers during the coming season will be Grafonola trunks, which permit a concentration on the sale of small portable instruments, the advertising fan as a publicity medium to be distributed at country fairs and at local gatherings of large bodies of people, the small Grafonola exchange sales plan and special appropriate summertime window appeals issued in connection with the regular monthly display service.

"The Grafonola traveling kit or complete portable outfit opens a new field for summertime sales among vacationists who are already convinced of the indispensability of the Grafonola to every summertime occasion.

"An entirely new selling angle on the small

account of its bulk and weight, but when a complete outfit ready for shipment is offered, this objection is removed and a large field for

rect fan and the carrier of a potential selling campaign.

"Tie-up' of the fan illustration to national advertising copy, in illustration and text, serves to identify the distributing dealer whose name appears on the fan as a part of the Columbia organization and to emphasize in the mind of the public the fact that that particular dealer's es-



Tying Up Window Display With Publicity



The Grafonola Trunk

Grafonola is suggested by the trunk. While many people would take a small phonograph to the country they are often reluctant to do so on

business among phonograph owners is opened. Folks who have the large cabinet type instruments do not care to subject them to climatic changes and other liabilities of damage by shipment to the shore or country. Yet, as music is indispensable to vacation and summertime activities, the small, portable Grafonola invariably proves a welcome solution.

"The complete, small Grafonola outfit assembled in the trunk and displayed in the window, either in connection with the regular Columbia monthly window display or a special window trim, will be productive of many complete outfit sales. The accompanying photograph shows a neat window trim and the card which accompanies the June display announcing the Grafonola trunk.

"A well built and substantial fan has a definite and useful life when carefully distributed. The better the fan the longer it will be kept and used by the public. If attractive in colors and interest-compelling in copy and illustration, the fan will work continuously during the Summer. In designing the Columbia fan for 1920, the Dealer Service department has taken into consideration all details that go to make a cor-

establishment is the one market-place in the territory where Columbia products may be purchased.

"Distribution was another element of serious thought. The fan must be such as to warrant its careful preservation in the hands of the public. This point was covered by past experience, good fortune in securing an exceptional quality of cardboard stock, a strong wooden handle and a perfected method of attaching the two. An instructing folder accompanies each shipment of fans to the dealer, offering valuable sales suggestions to Columbia dealers.

"The summertime feature of the Grafonola is further elaborated upon in connection with the Columbia monthly display service. The set for June, July and August will deal especially in illustration and text with suggestions for a musical vacation with the Grafonola.

"The June display pictured in connection with this article features particularly the summertime use of the Grafonola. The large centerpiece is an exact reproduction of the June Columbia advertisement which will run in the magazines, placing right in the dealer's window the last and telling shot of the big campaign.



## THIS SALESMAN

WILL

DISPLAY SUGGEST REMIND SELL

FOR YOU

## Dulciphone Needles

"The Highest Quality Needle in America"

MADE SCIENTIFICALLY OF THE HIGHEST GRADE CARBON STEEL. GUARANTEED TO PLAY THE LONGEST RECORD WITHOUT VARIATION AND WITH PUREST REPRODUCTION.

DEALERS' PRICE 6 1/2c. Per 100 to the Package | Your Initial Order for 200 Packages Brings the Handsome Display Case Free

Jobbers and Sales Agents write for our proposition to you

GRAND TALKING MACHINE CO., Inc.

Manufacturers of Dulciphone Phonographs and Dulciphone Needles | Distributors of QRS Player Rolls and Emerson Records | 366 Adams St., Brooklyn, N. Y.







**CONDEMNS COMPARATIVE PRICES**

**Indiana Fair Price Commissioner of Department of Justice Declares Extravagant Price Comparisons Shatter Confidence in All Merchants**

Advertisements which quote comparative prices and comparative values are dangerous by way of indicating to the public that the advertiser makes an unwarranted profit at the supposed "usual price," declares a bulletin to merchants which has been issued by Stanley Wyckoff, Indiana Fair Price Commissioner of the Department of Justice.

In citing this bulletin from Mr. Wyckoff the National Vigilance Committee of the Associated Advertising Clubs of the World says this is one additional reason why such advertising should be avoided.

"The reader of such an advertisement is likely to believe one of two things," says the bulletin. "Either he believes the statement, and therefore thinks that the merchants make an unfair profit at the usual price, or he disbelieves the advertisement, which is still worse."

In sending the bulletin to Indiana merchants the Fair Price Commission of Indiana had the co-operation of the Better Business Bureau (vigilance committee) of the Indianapolis Advertising Club. Mr. Wyckoff said, in part:

"The Fair Price Committee has received many complaints of suspected profiteering by Indianapolis merchants, occasioned by the use of extreme comparative prices and values in recent advertising.

"The chairman of the Fair Price Committee conferred with the president and secretary of the Better Business Bureau on this subject and it is our joint opinion that the use of extreme comparative prices and values is not only destructive of confidence in advertising, but is also creating distrust in the minds of the public to the effect that Indianapolis merchants are charging unusual and unfair prices in the regular course of business.

"A recent case reported by the Toledo, O.,

Better Business Commission is in point. A Toledo store advertised '\$100 value coats, \$65.' One of these coats was purchased and submitted to other Toledo merchants for appraisal, who placed a much lower value than \$100 on it. The coat was then sent to the Cleveland Better Business Commission and by them submitted to several of Cleveland's leading merchants, and the average value placed thereon was \$65, or exactly the sale price. This coat had undoubtedly been marked at the extremely high price of

\$100 only to be marked down for sale purposes. Such methods of merchandising are destructive and should receive the severest condemnation.

"The average reader of intelligence in reading such advertisements of great reductions at a time when the news and advertising columns are filled with stories of advancing cost and shortage in most lines of merchandise can only conclude that the merchant so advertising has either been making an unconscionable profit or is lying."

**TALKER MAY REPLACE ORCHESTRA**

**Everett Inventor Claims Future Holds Great Possibilities for Talking Machine—New Amplifying Device Fits All Instruments**

EVERETT, MASS., April 8.—Charles W. Harper, of this town, already an inventor of considerable fame, has just completed an electrical invention designed to amplify any musical instrument, and which can be used in connection with a talking machine, a piano, banjo or harmonica with equally good effect.

The first public demonstration of the invention was in Heineman House, Somerville, recently, and a talking machine was used to produce the music that was amplified until it rivaled a jazz band in point of volume and synopated melody. Although the instrument used was designed especially for orchestral records, there are others on the same order designed by Mr. Harper to amplify the voice.

The talking machine was placed in the balcony of the hall, and the tone was magnified through intensified electro-magnetic induction. Wires conducted the sound to a major horn, which threw the sound into the room. Electrical regulators make it possible to regulate the tone so that it will be almost a whisper, or to increase it to a volume that is deafening in intensity.

Mr. Harper predicts for the future of his invention a gradual substituting of the talking machine for orchestras in dance halls, and says

that it may also be used in churches, to take the place of chimes. It will fill a definite place in concert programs as well as in dance halls, he also claims.

The first demonstration was given before a large dancing class of young people of high school age, and they danced throughout the evening to the music furnished by means of this as yet unnamed invention, alternating with the orchestra. About fifty dancing teachers of Boston were also present, and were greatly interested in the development of an invention that promises to be of such great value to them in their particular business.

Mr. Harper is known already as the inventor of an instrument used very largely in schools for the deaf and dumb, by which deaf mutes are taught to talk. He also invented a self-setting automatic target, and his Harper oraphone for deaf people is appreciated by people throughout the world, who have found in it a means of communicating with their friends and with the world in general.

Sir Harry Lauder, the famous singing comedian and Victor artist, has reached England after his sixteen weeks' tour of Canada and the United States. His next tour to America, he says, will be in 1922 and that will be his farewell. Sir Harry is now on his way to South Africa. Following upon his stay in that country he will return to London, where he will open up in one of the London theatres under William Morris' direction.

**Of Vast Importance to Edison Disc Instrument Dealers**



Showing No. 95-A

A Queen Anne Creation. Designed expressly for use with the Chalet Model Edison Instrument equipped with the famous Eject-O-File Record Filing System. Produced in natural figured Red Gum and rouge Red. Dimensions: 20" wide, 22" deep, 32" high.

**"The Eject-O-File"**

The Eject-O-File is manufactured and owned exclusively by the Eject-O-File Co. Manufactured under U. S. mechanical and design patents.

The Eject-O-File is a most simple and efficient method of "Filing & Finding" disc Records at the desired time. Mechanism controlled entirely by gravity. Has no springs to get out of order and if you do not have an Eject-O-File in your home you do not realize what is best in Record Filing efficiency.



Showing No. 95

A straight line effect conforming with the Chalet Model Edison Instrument for which it is designed and produced. Equipped with the Eject-O-File Record Filing System. Dimensions and Finish same as No. 95-A.

Manufactured by

**THE EJECT-O-FILE CO., Inc.** HIGH POINT, NORTH CAROLINA

FACTORY AND GENERAL OFFICES

NORTH CAROLINA



# SONATA

TRADE MARK

# THE PHONOGRAPH OF PERFECTION

**THE GUARANTEED INSTRUMENT**  
PLAYS ALL MAKES OF RECORDS PERFECTLY

WRITE AT ONCE  
FOR  
**PRICES**  
AND  
ILLUSTRATIONS]



MODEL A

SCIENTIFICALLY CONSTRUCTED  
PIANO FINISH  
WHOLESOME NATURAL TONE  
LOUDEST OF VOLUME  
LATEST AND BEST MODIFIER  
PATENTED CONSTRUCTED HORN  
IMPROVED PERFECT SOUND BOX  
BALL BEARING TONE ARM  
NEW BEVEL EDGE TURNTABLE  
LATEST TYPE OF GUARANTEED MOTOR



MODEL B



MODEL C



MODEL D



MODEL E



MODEL G

**STANDARD PAPER COMPANY**

INDIANAPOLIS, INDIANA

**PHONOGRAPH DIVISION**

SOLE DISTRIBUTORS IN

ILLINOIS, INDIANA, MICHIGAN, WISCONSIN AND MINNESOTA



**GENERAL ACTIVITY HELPS "TALKER" TRADE IN BUFFALO**

**Big Wages at Leading Factories a Factor in Increased Demand for Talking Machines—Winegar Corp. in New Quarters—Brunswick Week Celebrated—Victor Record Recitals Attract**

BUFFALO, N. Y., April 7.—A boom that resembles wartime activities is being enjoyed by Buffalo's plants this Spring. The employes are receiving excellent wages and have plenty of money to pay for musical instruments. The local talking machine stores are likely to have many new customers shortly on account of the influx of a small army of new workmen and their families to this city. They will be attracted here on account of the opening of many new industries. Many of the plants report that they are unable to get sufficient help and are spending a total of thousands of dollars in advertising for this purpose. Even the trade of the unskilled laborer is becoming a powerful factor at the talking machine stores. The laborers are averaging \$6 a day and are not very far below the scale of the skilled workman. There was a time when the laborer or his wife expected to receive scant attention in a talking machine store. Now, on account of their prosperity, they are being handled with the utmost courtesy. The dealers are telling the old, old story that the supply of talking machines is far below the demand. However, on account of the good times and the abundance of money, they are viewing the future with real optimism.

An association representing the music and musical instrument trade may be organized in connection with the Buffalo Chamber of Commerce. Members of the trade have received the following note from that organization: "The advantages of organization, co-operation and interchange of thought and ideas are well known to-day. The past war has demonstrated what great results can be obtained through co-operation. An association representing the music trade would be of inestimable value to every concern who joined."

The familiar character, the town crier, is being used in some of the publicity of C. E. Siegesmund, Victor dealer. The words credited to the crier are these: "Hear ye! Hear ye! All and sundry, come buy in our shoppe ye new Victor records."

The Winegar Piano Corp. has opened a new talking machine and piano store at 935 Broadway. The store is spacious, newly furnished, well equipped and has individual booths. It has a fine new front. Five thousand Polish records are a feature of the stock. Mr. Winegar sells Columbia Grafonolas. He will conduct this store as well as his present one in the Teck Building on Main street. He is building up a staff of outside salesmen.

The Household Outfitting Co., which handles the Columbia line, reports that its store will not be interfered with in any way by the new Loew Theatre to be erected shortly.

Denton, Cottier & Daniels recently received a shipment of Aeolian-Vocalions. This concern was represented at the fifteenth anniversary of the Buffalo Rotary Club.

Buffalonians are heeding the warning that "talking machines must advance—everything else is steadily increasing in price." In speeding up their purchases they are stimulated by the knowledge that \$100 to \$1,000 has been added to the price of their favorite automobiles and that every other necessity or so-called luxury costs considerably more than in former days.

On account of its prosperity this Spring, the country trade is being cultivated in a vigorous manner by some of the local talking machine firms. Excellent weather and good roads are helping these drives.

Victrolas, Columbias and Sonoras are handled at the new Hertel avenue branch of Goold Bros. C. H. Goold is manager of this store. Mr. and Mrs. T. A. Goold have returned from a honeymoon trip to Porto Rico.

Reports that the Neal-Clark-Neal Co. had bought the property at the northeast corner of Delaware avenue and Mohawk street for a big music store, which are circulating in real estate

circles, prove to be a bit premature. It was said that the proposed building would exceed in size and completeness of equipment anything as yet attempted locally in the musical instrument field.

Beginning April 4 Brunswick Week was celebrated on an effective scale in this city. The Hoffman Co. at 96 Main street made a special feature of the event, and, to accommodate the crowds which assembled to study the Brunswick method of reproduction, the store was kept open evenings. The Ultona and the tone amplifier, features of this instrument, were demonstrated. Brunswick April records, including "Dardanella" and "Fast Asleep in Poppy Land," were played.

Arthur Middleton, the New Edison star, sang at the Elmwood Music Hall Tuesday evening, April 6. By means of special publicity the following firms, New Edison dealers, used Middleton's engagement as an occasion for calling the public's attention to that instrument: Bricka & Enos, J. N. Barrett, Frank Ehrenfried, Charles J. Hereth, the Utley Piano Co. and Zittle-Kreinleder Co.

Congratulations are being extended to L. K. Scott, manager of the William Hengerer Co.'s Victrola department over the recent birth of a son. D. A. Evans, of that department, is also the proud father of a baby boy. W. H. Tyler has resigned from the Hengerer Co.'s sales force to take a position with the Victrola department of McCreery & Co., Pittsburgh. Miss Julia White has been placed in charge of Hengerer's record department. Miss Hitzel, who was absent for some time on account of illness, has recovered and is again selling records at this store.

The Victor record recitals held in the concert room on the fifth floor of J. N. Adam & Co.'s store are proving a genuine success. They are in charge of F. E. Russell, manager of the Victrola department and are held on two afternoons early each month. Recital programs of new Victor records for the current month are mailed to a large list of customers of that store and the response, so far as expressed in attendance and enthusiasm shown, is gratifying.

Mr. Russell also gives interesting information

**Pretty Messengers with Record News**

Painted by famous artists of child subjects and lithographed in full colors on

**Nursery Rhyme Blotters**

Splendid means of featuring educational records and very attractive inserts for supplements and the regular mail.

**Price Lower Than Factory Prices**

Sets of 100—12 different subjects—\$8.10, without printing, postage prepaid.

In writing for samples, address Department "C."

**Stewart Talking Machine Company**  
Victor Distributors  
**INDIANAPOLIS, IND.**

about the artist responsible for the record. He reports that by means of this data extra interest is aroused. He injects plenty of human interest into this work and the audience listens with close attention to explanations of the careers of Caruso and other Victor stars. The recitals are advertised in the newspapers and personal invitations are sent out with parcels and to those on the company's mailing list. In the management of the concerts Mr. Russell is assisted by Floyd F. Barber. On account of this enterprise they attract many new customers to their department and extensively increase their record and talking machine sales.

G. W. Lawrence, Urbana, Ill., has closed out his furniture stock and is now exclusively a talking machine dealer.



**Follow Through!**

The music trade is spending a King's ransom in national advertising which is made doubly effective when it is "hooked-up" with the dealers through window advertising. Ask *your* manufacturer about the importance of window display.

**EINSON LITHO INCORPORATED**

NEW YORK 71 W. 23rd St. Originators of Window Advertising for Phonograph and Player Roll Manufacturers CHICAGO 332 S. Michigan Ave.





# Crafts Superiority

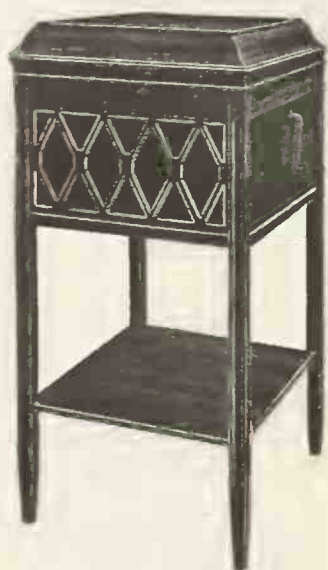

MODEL "A"

Mahogany or Oak  
17" wide; 19" deep; 42" high

This is an exceedingly artistic model, built to meet a popular demand. Nickel-Plated Hardware is used throughout, and the shelf for Albums is made of five-ply veneer.

is far-reaching, in that, regardless of territorial lines, the CRAFTS Phonograph is recognized as a leader by discriminating merchants in high-class musical instruments.

It is not difficult to convince a prospective customer of the superiority of the CRAFTS Phonograph. You have but to display the CRAFTS Phonograph in your show-room to arouse the attention of your visitors and hold their interest.

In any group of Phonographs, the CRAFTS stands prominently in the foreground because of the high-grade material used in its construction and the excellent workmanship throughout.

You work along "the line of least resistance" in handling the CRAFTS Phonograph. Your turnover, therefore, is quicker, your profit greater, with a minimum selling expense.

The above are a few of the reasons why the demand from the better class of dealers is constantly increasing and why we are arranging to have greater facilities for the manufacture of our product.

*Write Today for  
Dealers' Proposition*

**A. J. CRAFTS PIANO CO.**

Manufacturers

**RICHMOND**

**VIRGINIA**



MODEL "AA"—OPEN

Mahogany or Oak  
14½" high; 16½" wide; 20¼" deep  
Like the more expensive Models, "AA" will play all makes of Disc Records.



MODEL "B"—CLOSED

Mahogany, Walnut or Oak  
18" wide; 20" deep; 43¾" high



MODEL "C"—CLOSED

Mahogany, Walnut or Oak  
22½" wide; 24½" deep; 46¾" high



# HAPPENINGS IN THE DOMINION OF CANADA

## EVERY SIGN OF CONTINUED ACTIVITY IN TORONTO TRADE

Talking Machines and Records Figure in Easter Trade—Starr Co. Opens Western Branch in Addition to Toronto Headquarters—Tribute to the Victrola—Pathephone for Jack Norworth

TORONTO, ONT., April 8.—Nothing of an outstanding character has transpired during the past month and trade has shown signs of continued activity. Dealers reaped the benefits of a bumper Easter trade, which they claim is steadily growing every year. Records and talking machines are now accepted as appropriate Easter gifts, and a large number of dealers advertised this fact widely. Their windows bore cards advocating instruments and records as the Easter gift "supreme."

The Starr Co., of Canada, London, recently had a visit from Fred Gennett, secretary of the Starr Piano Co., Richmond, Ind., and A. F. Meyer, production manager of the same firm. Mr. Gennett spent several days in London and in that time visited three factories that are now producing Starr phonographs in Canada. He was very highly pleased with the organization in Canada and with the facilities for taking care of Starr and Gennett interests during 1920.

"While of course it is a difficult thing to say that we will have all the stock necessary to look after 1920 requirements," said W. D. Stevenson, of the Starr Co. of Canada, to The World, "we are in a position to absolutely guarantee established Starr dealers a wonderfully improved service commencing at once. We are in a position to turn out just seven times as many instruments in 1920 as in 1919. This means an increase in production of 700 per cent and will assure Starr dealers all over Canada of being in a position to take care of their trade in a very satisfactory manner."

"As you are aware we are also establishing a Western Branch, which will be in operation in the course of sixty days. This is in addition to the office opened up at 412 Ryrie Building;

Toronto, so that we expect in 1920 to be in a very admirable position to give our dealers a real service in addition to a line of merit."

Optimism means hoping. Peptimism means doing. You may hope to get value when buying a phonograph, but, if you're a peptimist you can get value by investigation, is the way D. D. Gordon, Ltd., Ottawa, Ont., advertises his new Edison and Columbia phonograph salon.

A Catholic priest in Ontario was so delighted with his Victrola that he sent a little poem about its excellencies, which expresses the matter very well. It reads as follows:

"VOX ET PRAETEREA NIHIL"  
I was old, but not forsaken,  
I had heard music by the score,  
Was too old to go and seek it;  
Could I hear it nevermore?

Yes, it comes to me in plenty,  
As I sit within my room,  
Classic, Ragtime, Bagpipes, Vocal  
All within my ear can boom.

Records of the sweetest music,  
Bring it all again to me,  
Victor Records by the dozen  
Fill my soul with ecstasy.

—Saeculum Vicesimum

It was the familiar Pathé rooster that caught his eye, so he dropped into R. F. Wilks & Co.'s store to buy a few records. The man was Jack Norworth, of the "Gaieties of 1919," and he was taking a little constitutional. Mr. Norworth is a Pathé enthusiast and always carries a Pathephone with his show to play in his dressing room during his "off stage" moments. Whilst in Toronto he was photographed listening to one of his own records in the Wilks Pathé parlors.

Max Rosen, exclusive Brunswick artist, recently appeared in recital in Massey Hall, Toronto. Brunswick dealers report an increased interest in his numbers since his visit.

## RECORD TRADE REACHES BIG DIMENSIONS IN MONTREAL

Increased Prices Help Rather Than Retard Demand—Window Signs Pay—Lindsay Concerts—Recital of Victor Artists Helps Business—Leading Establishments Augment Equipment

MONTREAL, CAN., April 6.—One of the features of the talking machine trade the past month was the unusually large sale of records. The increase of price of the Columbia records has seemed to help rather than retard sales. Almy's, Ltd., one of the largest Columbia dealers and who sells a great quantity of records, says that customers seem just as willing to pay the even dollar. It is now unnecessary to make change and this saves considerable time during rush hours. Some dealers say that this waiting for change was a good thing because it gave the salesman an opportunity to demonstrate some new record and often led to additional sales. The results of the business done the past month, however, seem to show that the increase in price has had no bad effect in this city.

"Window signs or stickers pay, and pay well," said W. W. O'Hara, the Columbia dealer, to The World, "and I'll tell you why. I had a customer come into the store the other day and before he went out he had purchased a large quantity of records and supplies. I had displayed a sticker announcing the sale of 'That Naughty Waltz,' which the purchaser had spotted from the windows of the street car. He told me that he had tried nearly every dealer on the street for this same record, but, although they had stickers on the window featuring it, they did not have it in stock, and I had hard work trying to convince him that I had it in stock, so you see it pays to stock what you advertise, rather than to advertise what you haven't got." Mr. O'Hara will shortly remove to larger premises across the way from where

he is, where he intends to put into practice several ideas which have been formulating for some time, but which have not been put into force owing to lack of accommodation. But with a store almost three times the size of his present one, he intends to carry a heavier stock of Grafonolas and Columbia records and feature this line more extensively than in the past.

In the phonograph salons of C. W. Lindsay, Ltd., free concerts are given every afternoon, except Friday and Saturday, between 3 and 5 o'clock, where admission is gratis. The Columbia and Sonora machines are being used in the demonstration with Columbia records.

The eight His Master's Voice artists who appeared personally in joint recital at the St. Denis Theatre drew capacity houses, and it has since been remarked that records of these particular artists have largely increased in sales.

Norman F. Rowell has returned to his old post as manager of the phonograph salons of C. W. Lindsay, Ltd., Columbia and Sonora dealers.

The Cowan Piano & Music Co. is doubling the size of its Victrola and record department which will make it possible to carry practically double the amount of stock now listed.

His Master's Voice, Ltd., has been incorporated for \$1,500,000.

A. C. Skinner, Ltd., Sherbrooke, Que., has installed the new self-serve stands holding 150 Columbia records.

In the circulation contest being conducted by the Sydney, C. B., Post, there figures a special prize of a new Edison diamond disc phonograph, Chippendale model, finished in mahogany, purchased from Travis Bros., of that city.

## SOME HAPPENINGS IN THE WINNIPEG TRADE

Canadian Representative of Sonora Tells of Activity in the Territory Which He Covers—Canadianization of Young Mennonites

WINNIPEG, MAN., April 5.—"No, I am not here to sell more instruments," said Emil H. Van Gelder, of I. Montagnes & Co., Canadian representative of the Sonora, who was in Calgary, Alta., for a few days on his way from Toronto to the coast, "but rather to get our Western branches to hold back on their orders for a little while since we are already oversold."

"We pride ourselves," continued Mr. Van Gelder, "on the fact that the machine we are offering the Canadian people is built of their own products, made by their own artisans in their own factories, and because of this we feel that we are entitled to receive their patronage." Mr. Van Gelder further showed what a good booster he was, not only for his own concern, but for Canada generally by declaring that it was about time the Canadian people put their buying-at-home power behind their dollar and lifted it back into the place among the moneys of the nations that it should be occupying.

A unique method of assisting the Canadianization of young Mennonites in the settlement at Wurtz, Sask., has come into use with the installation of talking machines in the public schools. "O, Canada," for example, is played on the machine first, perhaps, by a band, for band music is particularly inspiring to the young. Then a vocal record of the song is put on and when the children have learned words and melody they are taught the meaning and begin to sing. The talking machine is used also to furnish music for games and nursery rhymes, and the result of the entrance of the mechanical assistant has been the increased interest not only of the children, but the parents as well.

"The advantages of the talking machine in a place of this kind," says the teacher, "can only be faintly estimated by an outsider. Through it we have access to the best music. We hear

(Continued on page 193)

## Talking Machine Supplies and Repair Parts

**SPRINGS, SOUND BOX PARTS, NEEDLES**

---

### THE RENÉ MANUFACTURING CO.

MONTVALE, NEW JERSEY



## Announcement

Again we have outgrown our office and manufacturing facilities and have just added a third factory to our plants and have removed our offices to our new motor factory at 243 West 17th St., New York City

# Acme Motors Acme Tone-Arms Acme Reproducers

are still unexcelled and are the best value in the phonograph market today

## Acme Motors

In three types—two springs only. No untried or sensational features. Only conservative and proven designs of guaranteed dependability.

## Acme Tone-Arms

For small, medium and high-priced cabinets, all universal.

NEW FEATURE—Tone Modifier  
Embodied in the Tone-Arm

## Acme Reproducers

with mica or composition diaphragms. Five different types.

We make tone-arms and sound boxes to the manufacturer's specifications. Large manufacturing capacity and first class workmanship

# Acme Phonograph Corporation

NEW YORK CITY  
243 West 17th Street  
Tel. Watkins 6673

CHICAGO  
431 S. Dearborn Street  
Tel. Harrison 8021



**NEWS FROM DOMINION OF CANADA**  
(Continued from page 191)

the finest singers, and an idea of music as well as the other educational features of the work is instilled into the children's minds. In turn they take their little songs and stories of the good times we have home to their parents and they come eager to hear our concerts."

J. A. Banfield is running Saturday afternoon Grafonola recitals where vocal, orchestral and band music are demonstrated in this firm's new and attractive Columbia salons.

**AIDS CHILDREN IN MUSIC STUDY**

Toronto Globe Music Editor Points Out Value of Talking Machine to Lighten Labors of Arduous Study—Broadens Musical World

TORONTO, ONT., April 6.—The Music Editor of the Toronto Globe in a recent article on the Music and Drama page under the caption of "Labor Becomes Pleasure Through Services of Phonographs" said: "From a practical point of view the most valuable service that a talking machine in the teacher's studio can render is its day-by-day service as an inspiration to pupils in their work. It can add immensely to the interest of any piece that a pupil may be studying. For example, the young student who is being drilled on a small piece by Mozart may not find that particular piece very interesting, and may not know just why she is put at such a class of work. But give her an opportunity to hear one of the bigger works played by a real artist and the reason for the careful study of the little piece is plain, the labor becomes a pleasure because it is understood as a step toward the bigger accomplishment.

"If you are luckily situated you might be able to produce the same inspirational effect by sending or taking the pupil to a concert—but how much more simple to be able to produce it by merely putting a record on a talking machine, and how much more easy to explain and make your points as the record plays. Creating and stimulating interest is easy when the facile talking machine is at hand. It is always possible to bring forth ideals, to make a display of future possibilities that will pique the ambition, and make the drudgery of the hour seem less drudgery because a part of it becomes a very pleasant possibility. And the child who really knows about music is sure to be more interested than the one who does not.

but is merely slaving so many hours a day at finger exercises and study pieces, and has no vision of what the great world of music is, and what unlimited joys are in store when technique is achieved to a reasonable degree, and the power of expression gained.

"Few teachers realize how 'lonely' in a musical way most children are; how almost the only bit of the musical world they know is the little world that is presented to them by the few pieces they get from their teacher. It is in giving the pupils a broader vision into the world of music and in making them a part of a real, present and delightful universe of musical achievement that the talking machine does its finest and most helpful service. The teacher will find the talking machine and its music an invaluable aid in keeping up his own inspiration."

**R. L. KENYON AT HEADQUARTERS**

Has Completed Work of Organizing Plants of Independent Talking Machine Co. and Is Now Visiting the Various Dealers

R. L. Kenyon, who for a number of years headed some very active corporations manufacturing talking machines, and who for the past year has been in the work of organizing the various factories of the Independent Talking Machine Co., including those at Canton, Pa., and Elizabethport, N. J., has completed his work of placing that part of the firm's organizations on a most efficient basis and has returned to the home office of the company, 12 East Forty-second street, New York City. In the future he will, jointly with L. B. Williams, direct the sales of both the Independent Talking Machine Co. and the Amalgamated Phonograph Access. Corp.

Mr. Kenyon recently returned from a short trip in Pennsylvania territory, and is now planning a tour of the territories of the leading Independent dealers, for the purpose not so much of making sales as of keeping in close touch with the trade.

The Independent factories are now turning out machines of good quality, made to meet the exacting needs of the big dealers in highly competitive districts.

Kohls & Knaack, Watertown, Wis., have been appointed sole dealers in the Edison, which heretofore was handled in that city by the Stapleton Drug Co. Kohls & Knaack are one of the leading music concerns of the State.

**Disc Record  
Manufacturers  
ATTENTION**

If you are not satisfied with your product—

If some part of the manufacture needs perfection—

Let me help you.

I was the pioneer to introduce the present disc record into Europe in 1901. Successful factories were erected in England, France, Spain, Germany, Austria, and Brazil under my management. I know the record business from A to Z, and can straighten out your difficulties.

The present system of permanent masters was perfected in my laboratories in 1904 and has never been improved upon.

The double-sided record was my patent and brought out in 1903.

If you want the best to be had in recording machines; if you want the latest development in pressing records from shells; if you want increased record production in power-driven presses—I can help you.

Complete installations  
taken charge of

**F. M. PRESCOTT**  
RIVERDALE, N. J.

Phone No. 2 Pompton Lakes N. J.      Telegrams Prescott, Pompton Lakes N. J.

**THE CABINET & ACCESSORIES COMPANY**  
145 E. 34<sup>th</sup> STREET ··· NEW YORK



**LIST PRICE \$40**  
Regular Trade Discount

**THE PORTOPHONE**  
The talking machine with a double surprise  
Write for Catalogue

**'IN THE HEART OF NEW YORK'**

**GET ALL YOUR ACCESSORIES FROM ONE SOURCE**

- Standard Phonographs
- Lundstrom Converto Cabinets
- Record Albums
- Record Delivery Envelopes
- Rotolas
- Record-Lites
- Fibre Needle Cutters
- Cirola Phonographs
- Phonograph Cabinets
- Table Cabinets, All Kinds
- Talking Machine Toys
- Brilliantone Needles
- Velvetone Needles
- Red, White & Blue Needles
- Polishes and Oils
- Ready File Cabinets
- Repeaters and Rotometers
- Wall-Kane Needles
- Record Cleaners
- Dust and Moving Covers

All from One Source

**OTTO GOLDSMITH**  
President



# The Charming BEACON

*A Musical Masterpiece*

*There is considerable satisfaction in representing a line of merchandise that embodies quality and value.*

The BEACON Dealer is in a position to cater to the best trade in his locality, for the BEACON PHONOGRAPH is designed to satisfy the most discriminating and the most critical.

BEACON cabinet designs are distinctive and artistic; the motor, tone-arm and sound box are the best the market affords, and the tone quality is superb.

*We have a splendid proposition for progressive dealers. Write to-day.*

Five standard models, \$90 to \$225  
Period Models from \$375 up

## W. J. REILLY CO.

25 Sudbury Street  
BOSTON, MASS.

*Beacon Distributors for Maine,  
New Hampshire and Vermont*



Patents Pending

Model No. 6, Price - - \$125.00

Mahogany, Oak and Walnut

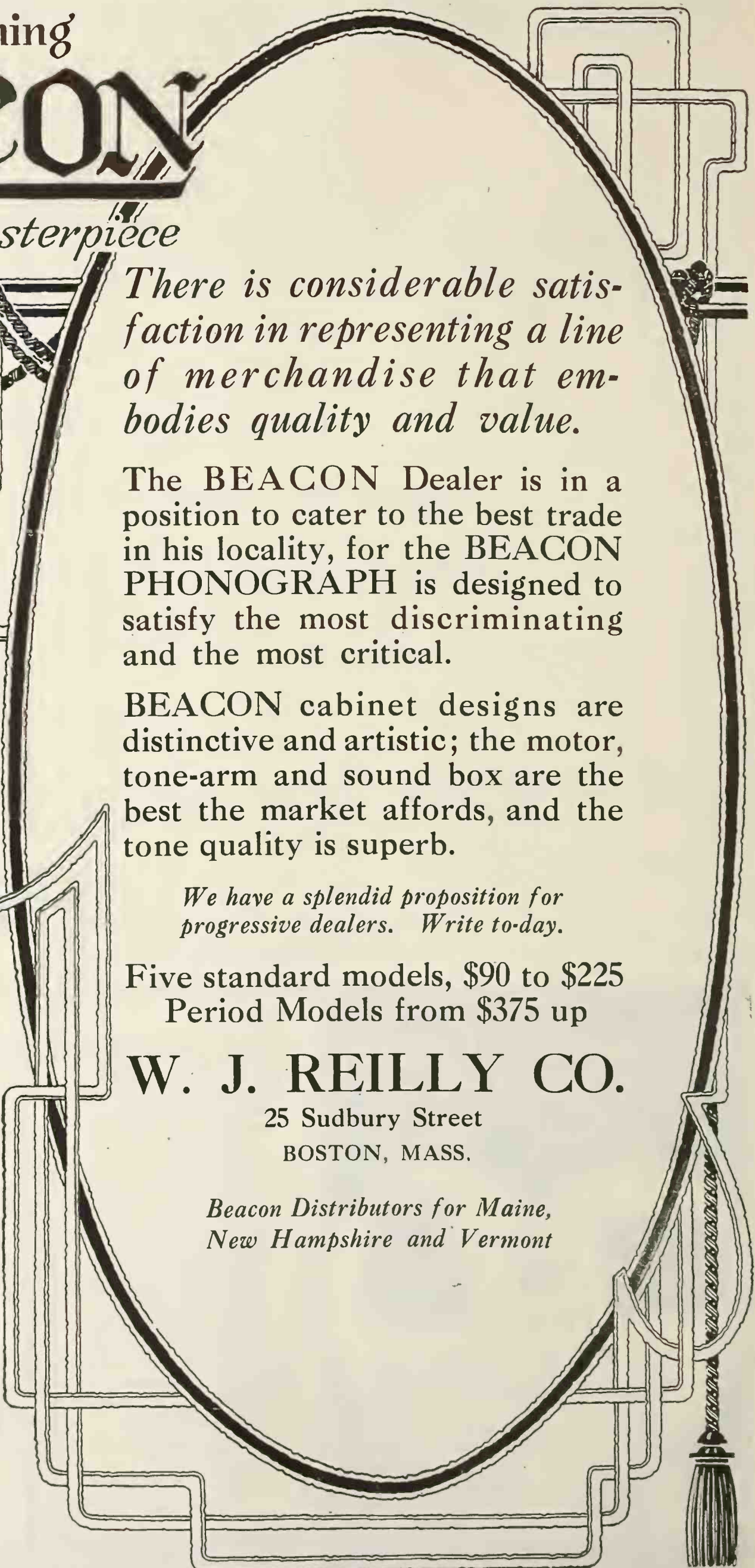



## HIGH GRADE INSTRUMENTS HAVE THE CALL IN DETROIT

The Period Designs Win Public Favor—Trade Forging Ahead Every Day—Janney-Bowman, Inc., Make Their Debut—Large Shipments of Stock Being Received—News of Month

DETROIT, MICH., April 8.—It seems to be the general report of all talking machine dealers, downtown and in the residential sections, that the public is buying the highest grade instruments. The Victrolas Nos. XIV and XVI seem to be in greatest favor, while in other lines those with period designs report a great demand. In fact, machines priced at \$150 and up are selling better than those at lower prices. In records, while the popular songs and dance numbers always lead, there is an increasing demand for the operatic records, showing that the high-class musicals and recitals given in Detroit this season are inspiring the masses to better things.

On the whole, it looks as though this is going to be the banner year for the talking machine dealer. In fact, it is the best three months the dealers have ever had and with Detroit forging ahead every day, increasing its population by leaps and bounds, and paying higher wages than ever, the talking machine dealer who properly exploits his merchandise is going to reap a harvest. Dealers say the recent advances made on talking machine prices have been a good thing for the industry because they give the dealer an increased profit, while the public is not complaining.

Janney-Bowman, Inc., have opened a Detroit store at 43 Washington boulevard, and while for the present they are confining themselves exclusively to the Knabe, Ampico, Franklin and other instruments made by the American Piano Co., they are considering installing a high-grade talking machine department.

The Adora Phonograph Co. during the past thirty days opened a new store at 683 Woodward avenue, which is in the Orchestra Hall Building, and one of the best locations in Detroit. This makes their eighth store in the Motor City.

Wallace Brown, 31-33 East Grand River ave-

nue, now has four retail stores devoted exclusively to the Brunswick. Besides his main store, he has one on Chene street in the Polish section; another in Springwells and another at 1453 West Warren avenue.

The J. L. Hudson Co., in speaking of Emerson records, recently made this interesting announcement: "Our experts studied these records, examined the list of artists singing popular songs and playing catchy dance music. They found that the Emerson ten-inch records are of a fine quality—the music is well played originally and is well reproduced. Some people prefer Emerson dance records to any other kind." This store is doing a big business with them.

### WHERE GRAPHITE COMES FROM

Some Interesting Facts Regarding the Sources of That Important Lubricating Material

Owing to the extensive use of graphite for lubricating purposes in talking machine motors, and particularly in the springs, facts regarding the source of the graphite supply should prove of interest to the general trade.

Austria gives the greatest output, but Ceylon is a close second, and we are told that the finest graphite at present mined is obtained from the latter island. The industry in Ceylon seems to be carried on by the villagers in a somewhat primitive manner, and many of the mines are worked only when the price of graphite is high. A few have been worked on European lines, but not as a rule with much success, as the deposits are irregular and inclined to soon give out. The principal deposits of Austria are in Bohemia, adjoining the graphite region of Bavaria. The most valuable deposits are the "Fürstlich Schwarzenberg'schen Werke" at Schwarzbach, where three layers are exposed. The center

Shipments of talking machines to Detroit were improved the past thirty days, but it's still the old story of a scarcity of the most popular models. This applies to all the different lines.

Buhl & Sons, who are now the Michigan distributors for the Vitanola, are putting on a great many new dealers and are reporting a very brisk business.

Burglars entered the store of Max Strasburg Co., Library avenue, Sunday evening, April 4, and took the safe to the rear of the store, but were unsuccessful in opening it.

E. P. Andrew, general manager of the J. L. Hudson music store, returned April 3 from a two months' trip to California.

"Dardanella" continues to be a big hit in Detroit, but the new hits are "Venetian Moon," "When My Baby Smiles," "Swanee" and "You'd Be Surprised."

bed yields the "fett" graphite, a soft, earthy variety of such purity that it is placed on the market in its natural state after some small concretion-like aggregates of silicates have been removed by hand. This has a fine flaky structure, and is employed for pencils. It appears to be closely allied to the Borrowdale graphite. Italy is the third largest producer of graphite, it being worked in the northwest, near Pinerolo in the Vaudois on the Cottian Alps, and near Bagnasco in the Bormida Valley, a portion of the Maritime Alps. Other smaller producers of graphite are Germany, in the neighborhood of Passau, in Bavaria; Russia in Asia, where but little work is now being carried on, though the graphite obtained from Batugol, near Irkutsk, was manufactured into pencils of the finest quality; India, where it is found in many localities. It is also met with in New South Wales, Victoria, Queensland, West Australia, South Australia, New Zealand, in various localities in Canada, United States, Mexico, South America, Cape Colony, Rhodesia and British Central Africa, British East Africa and Uganda and Northern Nigeria.

# The Brooks Automatic Repeating Phonograph

DISTINCTIVE—SUPERIOR—MUSICALLY PERFECT

The BROOKS Automatic Repeating Phonograph is the wonder instrument of the industry.

The Automatic Repeater and stop device is an exclusive Brooks feature and can be found on no other phonograph. It is not an experiment, but is a proven success, having been placed on the market over two years ago. It combines extreme simplicity with absolute accuracy.



This is only one of the many BROOKS features. The cabinet work is superb. The mechanical equipment is unexcelled, and the tone quality satisfies the most critical music lovers. The BROOKS phonograph will appeal to everyone who appreciates quality and merit.

Send for our new illustrated catalog. Showing all models.



Model 165

The First Really Complete Phonograph

Write to our nearest Jobber for dealer proposition

**Brooks Mfg. Co. Saginaw, Mich.**

### JOBBERS

Oakland	CALIFORNIA	A. Schlueter & Co.	Buffalo	NEW YORK	The Walters & Barry Corp., 256 Main St.	Pittsburgh	PENNSYLVANIA	Newton B. Heims, 3009 Jenkins Arcade
Atlanta	GEORGIA	Consolidated Phono. Co., 307 Peachtree St.	Ogallala	NEBRASKA	The Repeating Phono. Co.	Spokane	WASHINGTON	Northwest Phono. Jobbers, Inc., 911-915 Riverside Ave.
Chicago	ILLINOIS	Manufacturers Agency, 824 Republic Bldg.	Dayton	OHIO	Lawrence & Klemm, 1329 Alberta St.	Huntington	WEST VIRGINIA	Kenney Music Co., 331 9th St.
Saginaw	MICHIGAN	Morley Brothers, Brooks Mfg. Co.	Cleveland		Tiffany Phonograph Sales Co., 312 Racine Bldg.			





**George Meader sings two tenor love songs  
—“Sunrise and You” and “I’ll Think of  
You When Evening Shadows Fall.” You’ll  
sing his praise when you count your profits.  
A-2886.**

**Columbia Graphophone Co.  
NEW YORK**

## DEMAND IS FAR IN EXCESS OF SUPPLY IN NEW ORLEANS

Despite Unfavorable Weather the Standard Types of Machines and Records Are Actively Called For—Leading Concerns Are Optimistic and Perfect Plans for a Great Season of Activity

NEW ORLEANS, LA., April 6.—It isn't a question of how good business is in New Orleans. Although there seems to be some slight relief from the shortage of machines and records, due mainly to transportation congestion, the demand is far in excess of the supply. Rainy weather and several distractions have not halted the buying, and the purchasers of records as a rule are not shoppers taking home one. They don't often carry their purchases and this results in larger orders; lots of a dozen or more.

There has been quite a change in the demand for types of talking machines in this territory during the past year. The table type is not wanted to-day. As one salesman expressed it: "Purchasers have gotten the idea the table type is a plaything and now they want the cabinets." This change has been gradual, due probably more to a greater interest and desire for talking machine music than to any kind of advertising.

Philip Werlein, Ltd., Victor distributor, says business never has been better than this Spring. Likewise John V. Dugan, of Dugan Piano Co., exclusive Victrola retailer.

"In spite of the inadequate supply of instruments and their re-creations," L. T. Donnelly, manager of the Diamond Music Co., Inc. (Edison), said, "March has proved the banner month in the history of the Diamond Music Co."

B. G. Powell, manager of the talking machine department of Maison Blanche, made a trip through the East and North last month. He was in Philadelphia, New York and Chicago. He attended the Victor record salesmanship school. His department sells the Brunswick, Columbia and Victor lines.

The Dugan Piano Co., agent for the Victor machines and records, exclusively, has begun regular Saturday afternoon Victor recitals for children. Miss Mary Conway, director of music in the city's schools, lectures to the children and explains the records to them. Mr. Dugan says sales have been increased, although the scheme has been in effect only three weeks, because the children go home and tell what they have heard. Of course the recitals are free. This has been made one of the regular features of that store's educational department.

George A. Chopin, assistant manager of Holmes Aeolian-Vocalion department, has resigned. No successor has been named. R. E. Ching, manager, will handle Mr. Chopin's work temporarily.

C. H. Tracy, of the Aeolian Co.'s Vocalion wholesale department, New York, was in New Orleans last month.

Holmes advertisements will feature Aeolian-Vocalion records made by Marie Sundelius and Florence Easton, Metropolitan opera stars, when they appear in New Orleans with the Scotti Opera Co. May 4 and 5 at the Tulane Theatre.

During the past month two Columbia artists have appeared in New Orleans: Riccardo Stracciari, who was brought here by Robert Hayne Tarrant, now with the musical information department of L. Grunewald's House, and Josef Hoffman, who appeared March 3.

Dealers are expecting the Columbia record shortage, felt here because of transportation congestion, to be relieved shortly. It is reported more records came through last month than was really expected in face of the transportation conditions. The Columbia branch house still

reports considerable demand from the activities and publicity of Novelty Week.

A. B. Creal, manager of the Columbia branch, was in Mobile week before last. He says business is increasing steadily there, which, he declares, indicates a healthy condition. Mr. Creal found the Jesse French & Sons house in Mobile, managed by T. B. Parsons, doing a fine business, resulting from using original advertisements, three and four columns wide, in the daily papers, telling of the actual records the house had in stock.

E. L. Ested, salesman with the Columbia branch, has been through the rice-growing section of Louisiana during the month. He says there is every indication of increased prosperity there as the crops are in good condition.

The Sharp Furniture Co. in Natchez, Miss., retailer of the Columbia exclusively, is going to put in three more hearing rooms and has a well-equipped place.

Another Columbia dealers' meeting is to be held in New Orleans April 22, similar to the one held in February. Dealers will be asked to participate in a program along new and different lines. There will be nothing theoretical, Mr. Creal declares, but actual demonstrations of solutions of the smaller dealers' problems as well as those of the "big houses."

J. A. Abrams, who has been operating an exclusively Columbia shop in Biloxi, Miss., has opened a second store in Gulfport, another Mississippi town on the Gulf Coast.

New retailers of the Columbia line in the New Orleans territory are: The Oakdale Furniture & Trading Co., Oakdale, La., which has been successful with other lines and is now exclusively Columbia, and Charles Lewis, Magnolia, Miss.

The Diamond Music Co., distributors of the Edison line in the New Orleans territory, has added another road man, viz.: J. W. Stromberg, formerly a salesman in the Diamond Disc

**FOR VICTOR SERVICE**  
**PHILIP WERLEIN, Ltd.**  
**OF NEW ORLEANS**  
**THE LEADING SOUTHERN WHOLESALERS**



**Van Veen**  
"BED SET"

**Booths  
Sectional  
Record Racks  
Record  
Sales Counters**



**VAN VEEN "BED-SET" EQUIPMENT PAYS FOR ITSELF**

We place the proof before you. The illustration shows the second successful installation within two years for Kirsner Bros., Brooklyn, N. Y.

Van Veen "Bed-Set" Hearing Rooms sell the goods — an unsalaried selling force.

**ARTHUR L. VAN VEEN & CO., 47 West 34th Street, New York**

Telephone Greeley 4749

Shop, the retail store in New Orleans. This has been done to reach the dealers more frequently and to more thoroughly cover the territory. The section has been divided into three parts. The two other salesmen are Russel Hardy, an experienced phonograph salesman, and J. E. Ferrand, who recently was discharged from the army.

New dealers established by the Diamond Music Co. are: R. N. Hudson at Mobile, Ala., who is putting in a Diamond Disc Shop in charge of a special man, C. Greene; White Brothers Hardware Co., at Philadelphia, Miss.; Union Drug Store, Union, Miss.; Tech Music Co., Abbeville, La.; Wright & Colmer, Moss Point, Miss.; G. C. McKinnon, Marianna, Fla.; Fred W. Smith, Poplarville, Miss., and L. J. Rhoades, Houma, La.

The Diamond Disc Shop will have a tone test by Alice Verlet and Victor Young at the Little New Theatre, Grunewald Hotel, April 30. Miss Verlet will cover the greater part of the Diamond Music Co. territory in a five weeks' tour, started April 5 at Galveston, Texas.

L. T. Donnelley, manager, and A. Schreiber, secretary of the Diamond Music Co., attended a regional convention of Edison jobbers at Atlanta, March 12 and 13, at which T. J. Leonard, general sales manager, Thos. A. Edison, Inc., and the jobbers at Atlanta, Richmond and Cincinnati were present with their sales forces.

Charles Addams, wholesale Aeolian-Vocalion man, was in New Orleans three days last week at the special invitation of R. E. Ching, manager of D. H. Holmes department store's music department, exclusive Vocalion retailer and wholesaler. Mr. Ching formerly was with the

Aeolian Co. and when at a convention a few months ago invited Mr. Addams to come to New Orleans. The Holmes music department's staff entertained him and in return he spent considerable time acquainting them with Aeolian ideals. He held two classes daily for three days and brought out many points not before appreciated. When he left, the entire staff was hoping for an early return visit.

The Holmes Co. has had the representation of Vocalion four years, but in all that time the factory has been unable to completely fill all orders, and it has hindered the wholesale side of the house's music department. Despite this, there are forty dealers retailing Aeolian-Vocalions under Holmes. This has been made possible by the vigorous efforts of Mr. Ching, who retains his enthusiasm for Aeolians which he absorbed when with the factory sales force. He says there is a great future for the Vocalion in this territory.

**INCREASES EQUIPMENT**

J. J. H. McLean Co., Ltd., Winnipeg, is installing twenty-four sound-proof demonstration rooms. Twelve of these are on the ground floor and twelve on a mezzanine gallery. These rooms are being tastily decorated and fitted up in every way to make pleasant surroundings for the choosing of phonographs and records.

The Merlon Corp., Newark, N. J., has been incorporated under the laws of New Jersey to manufacture talking machines, player-pianos and other musical instruments. The capital is \$125,000.

**BLISS REPRODUCER FILES SCHEDULES**

The Bliss Reproducer, Inc., New York, manufacturer of phonograph parts, 80 Fifth avenue, has filed schedules in bankruptcy with liabilities of \$49,441, represented by wages, \$362; secured claims, \$3,983; unsecured claims, \$17,477; notes and bills, \$27,618, and assets of \$100,828, consisting of cash on hand, \$81; stock, \$17,897; machinery, tools, etc., \$3,181; patents, etc., \$24,866; accounts due, \$4,774 and \$9,007; unliquidated claims, \$50,000, and deposits of money in bank, \$298. The Credit & Finance Co. is a secured creditor for \$3,083. Among those who are unsecured are John D. Evans, \$17,000; Columbia Trust Co., \$5,000; Titan Auto. Tool Co., \$4,317, and Standard Metal Mfg. Co., \$3,991.

**UTILIZING SURPLUS RECORD STOCKS**

CLEVELAND, O., April 5.—Howard J. Shartle, manager of the Cleveland Talking Machine Co., has perfected a system whereby dealers in the territory served by the company and even further away may take advantage of any surplus stocks of records that are in the hands of brother dealers in the territory. Dealers who are in possession of certain numbers that are more than sufficient for their ordinary requirements list these surpluses with the Cleveland Talking Machine Co. These lists are then compiled into such a form that dealers can see what is available from their brother Victor representatives and take advantage upon an exchange basis. This is a move along the lines of efficiency and should be greatly appreciated by the trade.

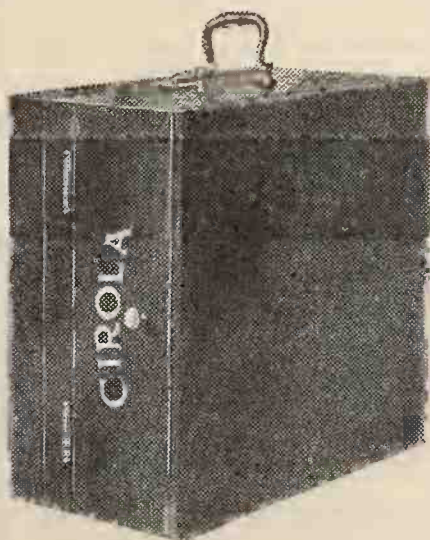

Size: 6" x 6" x 12"

**"Take Your Music With You"**

"CIROLA," the only PORTABLE Phonograph without sound chamber; has twin spring motor; highly nicked metal parts; is finished like a Piano; built like a Battleship; folds like a suitcase; weighs 16 lbs.; plays all records better because the good fresh air is its sound amplifier; and we will give \$10,000.00 for any Cabinet Phonograph at \$100.00 that will produce a larger volume of tone. Write for our proposition quickly. Enterprising dealers everywhere are rapidly stocking these Spring and Summer Whirlwinds.

**CIROLA DISTRIBUTING CO., Inc.**

Distributors of the

**CIROLA PHONOGRAPH**

PROMPT  
DELIVERIES



203-04 Colonial Trust Bldg.  
Phone Spruce 6340  
**PHILADELPHIA, PA.**  
U. S. A.





# ANALYZE SERIOUSLY

## Mr. Victor Dealer

VICTOR dealers who have been successful over a period of years or expect to build a permanently profitable business will consider seriously the best policy to encourage and protect "goodwill."

Business conditions during the last few years have been upset and former carefully guarded policies and practices have been disregarded or abandoned either of necessity or through the lure of immediate profits.

Employees have left positions after years of service regardless of the inevitable readjustment bound to occur when the law of supply and demand will give first consideration and preference to loyalty.

Some VICTOR dealers likewise have yielded to the temptation of immediate increased sales and profits by selling instruments and records of questionable quality and value.

Analyze seriously, Mr. VICTOR Dealer, the way to insure a permanent goodwill among your customers and a profitable business and adopt *now* a policy accordingly.

VICTOR production is being greatly increased but it will be some time before it will even approach the demand. Meanwhile preference in the distribution of increased VICTOR production should, in our judgment, be on a basis of reciprocity.

Take inventory, Mr. VICTOR Dealer, of your past and present policy and analyze seriously your best future policy.

It is part of our service to help you solve this problem and we welcome an opportunity to do so.



*Blackman*  
TALKING MACHINE CO.  
81 READE ST. NEW YORK N.Y.  
VICTOR DISTRIBUTORS - WHOLESALE ONLY





# GLEANINGS *from the* WORLD *of* MUSIC

## WHY DEALERS SHOULD WATCH PUBLISHERS' PUBLICITY

By Capitalizing All Available Publicity in the Field in Regard to Songs and Records the Dealer Is in a Better Position to Reach the Public Effectively and Score Satisfactorily

From time to time we have mentioned in these columns that it pays the talking machine dealer well to keep in touch with the publicity campaigns inaugurated by the various music publishing houses. By using such knowledge it is possible for the dealer to judge what numbers will be among the largest sellers. More especially, the dealer should look with eagerness for the material issued by the leading publishers and designed by them for particular records placed in the jobber's hands for the use of the trade in general. Much money is being spent in this direction and some highly artistic hangers, cutouts and other publicity material are being issued regularly.

The dealer in using such material not only creates new sales, but the attention of the public, which has already been "sold" on a particular number, is thereby attracted to his store. In this manner he cashes in on publicity which originally emanated from another source.

When a publisher issues special publicity material for a particular record, each piece of which costs from ten to seventy-five cents, often more, the dealer may realize that the publishers have the utmost confidence in the number's ability to have a large sale, for before appropriating money for that purpose, the number has demonstrated its value to them from several directions. There is little guesswork in the matter.

It is true that in publishing popular songs there is a good deal of gamble—one never knows just what will take with the public—

what the public wants. But all the gamble is eliminated by the time the publishers are ready to appropriate money for publicity of individual records.

In addition to the material coming from the publishers themselves, the record manufacturers, as well as the jobbers, often furnish such a publicity service. True, in some of these cases there is a nominal charge, but the material is elaborate, specially designed, and the numbers advertised are selected with great care.

In order to capitalize all the publicity material the dealer is able to procure from the sources mentioned some judgment must be shown in their use. For instance, material on a strictly novelty number must be used at once and placed in a conspicuous position, for the popularity of such numbers is often short-lived. The sale, however, of such numbers, when they are at their height are always in large volume. Musical comedy numbers will sell over a longer period and those especially advertised will have a steady sale with an increased demand being shown, of course, when the show itself is playing in the dealer's city. A number of the ballad order selling over a long period, as is generally the case once the song becomes popular, hardly needs a special campaign. The publicity material can be of a more permanent kind, as it will often be in use for a period of months. The sales of such numbers can be increased by special campaign but, as many of them often become practically "standards," merely calling

the attention of the trade to the title is enough to sell the goods.

Such numbers as "Kiss Me Again," "The Radiance in Your Eyes" and "Think, Love, of Me," have won a position in the standard catalogs of the houses by which they are published and their sales in record form are steady.

## SHEET MUSIC AND RECORD COMBINED

Clever Idea Put Before Publishers by the Talking Book Corporation of New York

A special meeting of the members of the Music Publishers' Protective Association, the organization composed of popular publishers with headquarters in New York, was held recently at which a proposition made by the Talking Book Corp., New York, to co-operate with the music men in the issuing of a new type of musical publication was made.

The Talking Book Corp. has on the market a combination phonograph record and Mother Goose story book; and the proposition to the music men is the publication of a song, the back page of which will be in the form of an envelope which will contain an indestructible record of an orchestration of the number.

The record will not carry the words of the song, but simply a well made orchestral reproduction by means of which the purchaser can in his own home put the record on his talking machine or phonograph and sing the song to the accompaniment of a full orchestra.

The idea is novel and attractive, and whether or not the publishers and manufacturers can come to any definite understanding, it at least is being given serious consideration.

Yes, we are traveling very fast putting them over with another **Sensational Hit by Fred Fisher**, who gave you history's quickest hit, **Dardanella**:

Entitled

# DADDY, YOU'VE BEEN A MOTHER TO ME

You are getting terrific demands for this song, IT'S a natural hit

We have several surprises that will be the talk of the music business. We are out to break all records. Keep your eye on these titles

1. **"When the Sun Goes Down in Cairo Town"**  
By Johnny S. Black and Fred Fisher
2. **"Way Down Barcelona Way"** (That Diddle-de um de-dum)  
By Harry Jentes and Fred Fisher
3. **"The Dardanella Blues"**  
By Johnny S. Black and Fred Fisher

SEVERAL IMPORTANT ANNOUNCEMENTS WILL BE ISSUED SHORTLY

**FRED FISHER, Inc.**

224 WEST 46th ST.

(Formerly McCARTHY & FISHER, Inc.)

NEW YORK CITY



OWENS' PHENOMENAL DANCE SENSATIONS OF 1920

MOONDRIFT (Waltz)

By Sidney B. Holcomb and Chas. L. Lewis

I'M ALWAYS DREAMING DREAMS (Fox-Trot)

By Chas. W. Allen and R. Joseph Mazza

Your Player Roll or Phonograph Record Counter Should Have These Numbers, Mr. Dealer!

THE DENNIS B. OWENS, JR. CO. INC., Music Publishers, KANSAS CITY, MO.

VICTOR CO. DINES SUPERVISORS

Mrs. Frances Clark of the Educational Department Is Hostess at Final Banquet of Convention Week of Supervisors National Conference—Many Victor Artists Appear

PHILADELPHIA, PA., April 6.—This city last week entertained some 1,217 professional directors of music in educational institutions who met here for the convention week of the Music Supervisors National Conference under the presidency of Dr. Hollis Dann of Cornell University. The value of the talking machine in musical education was a topic which interested the entire membership and many supervisors of music told what had been accomplished in their particular communities.

At Tuesday's sessions Dr. Dann entered his earnest plea for teachers' salaries commensurate with higher musical standards, and the potent influence of the art upon our national life, expressing the belief that community music and the music in the public schools are of fundamental educational importance. George H. Gartlan, director of music in the schools of Greater New York, deplored the low standard of taste in popular music now prevailing, and decried the business connection of supervisors of music with the educational departments of publishing houses. Dr. Frank Damrosch declared that the country is fast outgrowing the formal routine of "methods."

At the final session these officers were elected: President, John M. Beattie, of Grand Rapids, Mich.; first vice-president, Julia E. Crane, Potsdam, N. Y.; second vice-president, Peter Dykeman, Madison, Wis.; secretary, Miss E. J. Wisenall, Cincinnati, Ohio; treasurer, Frank A. Beach, Emporia, Kan.; auditor, Philip C. Hayden, Keokuk, Iowa. Mabelle Glenn, of Bloomington, Ill., was made a director for five years, and Ernest Hesser, of Bowling Green, Ohio, was also elected.

The feature of the final session was the banquet given by the Victor Talking Machine Co., at which Mrs. Frances Elliott Clark, director of the educational department of the Victor Co., presided as hostess. Mrs. Clark outlined in detail the work which her department is doing in advancing the musical education in the schools of this country and pointed out the advantages of a good system in every school. She made a plea that every supervisor of music give careful thought to the individual problems of his or her community in order that the best interests of music might be served. Other speakers were John H. Finley, New York State Superintendent of Education, and Lee Driver. Among the Victor artists who took part in the musical program of the banquet was Princess Watahwaso, of the Penobscot tribe, who appeared in native costumes and sang Indian songs. Reinald Werrenrath and Fritz Kreisler also participated.

LARGE MICA DEPOSITS IN BRAZIL

Mica of a superior quality is found in large quantities at Itapecirica, Iguape, Brazil, and in the region of Serra do Mar, especially in the municipal district of Parahybuna. Mining operations are now being carried on at Lavras, on the Sao Lourence River, in the vicinity of Itapecirica. This property, which belongs to Dr. Paulo Alvaro, of Asuncion, has already produced large quantities of mica for export. The quality of the mica from this mine is that known as ruby, but there are many other varieties found in the State. The countries to which the Sao Paulo product is shipped are England, France, Italy, Germany and the United States. says a report of the Bureau of Foreign and Domestic Commerce.

SHE DIDN'T NEED IT AFTER ALL

She was a red-checked English girl, who had come to America to stay—so she told the little man in the phonograph shop.

"I've only been here ten days, you know," she explained, "and I'm afraid this American slang of yours will be hard for me to catch on to, eh? So I thought I would like to buy some of these talking machine records of yours, do you see?—some with the newest slang on them, to help me in being—what-do they say?—oh, a hundred per cent American!"

The little man cranked up a high powered music machine and put on the latest Winter Garden hit. The damsel from Albion frowned

thoughtfully while its strains blared forth. Was the slang too complicated for her? the woman wondered.

"Can that," came the answer, in creamy English accents.

"What?" gasped the little phonograph man. "I said you could can that," reiterated the English girl.

The machine stopped with a click. The phonograph man mopped his brow. "Ten days in America!" he muttered. "Lady—believe me—you don't need any records!"—N. Y. Evening Sun.

Canadian dealers are busy with plans for "Miami Week" in the Dominion.

Alabama Moon

THAT HUMMING STRUMMING MELODY

Published Song and Waltz

Get This Right

Alabama Moon Is a Lucky Strike!

A Melodious Melody

What is a Melodious Melody? It is more than a Melody—a ringing, singing strain that you can't forget. Everybody is wild about the dreamy swing of this crooning moonlight song. It's a melody you can sing, whistle and hum.

Now Being Featured Everywhere

10,000 orchestrations and song copies sent to orchestras and singers all over the universe.

Accepted by Every Leading Talking Machine and Player Roll Company for Early Release

SEND IN YOUR ORDER—DISPLAY COPIES AND RECEIVE YOUR SHARE OF ITS GROWING POPULARITY

If You Are a Live Wire Dealer

and your name is not on our mailing list, fill in the appended coupon blank and receive advance information on our new issues and keep up-to-date on Fox features.

Please place my name on your dealers' mailing list. I am a bona fide sheet music dealer.

Name .....

Address .....

City .....State.....

Sam Fox Pub. Co. Cleveland.



**Men Who Make Popular Songs**

No. 11—L. Wolfe Gilbert

Some time ago L. Wolfe Gilbert celebrated the occasion of his writing his one thousandth popular song, which fact alone demonstrates that, despite his youth, he has been a successful, as well as a prolific, songwriter. Successful because one is not apt to brag about writing one thousand songs unless a goodly number of them were accepted as works far above the mediocre. In addition, the fact that some two years ago he



L. Wolfe Gilbert

branched out into business for himself, proves that his writings have been remunerative.

L. Wolfe Gilbert first came into the limelight as the writer of "Waiting for the Robert E. Lee," quickly followed by "My Little Dream Girl," "Hitchy-Koo," "Campmeeting Band," and the greatest "nut" song of all time, "Lily of the Valley."

More recently he has given us "Afghanistan," a number which jumped into immediate favor, "Granny," "Sunny Southern Smiles," "Mumsey," "Our Quarrels, Dear," and "Dance-O-Mania," which has promise of becoming one of the season's biggest dance hits—so they all say!

Hinds, Hayden & Eldredge, Inc.

11 UNION SQUARE, NEW YORK CITY

PUBLISHERS OF

**"SOUTHERN LULLABY"**

ANNOUNCE

**"IN THE AFTER GLOW"**

By

J. WILL CALLAHAN

Author of

"Smiles" and "Tell Me"

FRANK H. GREY

Composer of

"Think, Love, of Me" and other successes

Programmed by America's Foremost Concert Artists

**RAINBOW ISLE**

By BETTY BENTLEY and JAMES W. CASEY

Feature theme in D. W. Griffith's New South Sea Island Picture, "THE IDOL DANCER," now shown in every town. A WALTZ SONG THAT WILL SURELY SWEEP THE COUNTRY

OUR HITS: UNDER WESTERN SKIES LITTLE JO DOWN KENTUCKY WAY SANDY

Order Direct or From Your Jobber

ECHO MUSIC PUB. CO., Peoples Bank Bldg., SEATTLE, WASH.

L. Wolfe Gilbert personally enjoys a degree of popularity with the public no less great than that of his songs. He has just embarked upon another vaudeville engagement of twenty weeks, and at each theatre he will be "headlined," and it may be predicted that, upon his past performances, these honors will in each instance be proven deserved ones.

**ALBERT SPALDING TO EUROPE**

Albert Spalding, the American violinist and Edison artist, has been chosen to accompany the New York Symphony Orchestra on its forthcoming tour to Europe at the special invitation sent him by officials of the French and Belgian governments.

**CLIMB TO SUCCESS ON BELWIN HITS**

**HUNK-A-TIN**  
Lyrics JULIUS ROMANO Music SOL P. LEVY

**MADRIOLA**  
Lyrics JULIUS ROMANO Music SOL P. LEVY

**WHY**  
Lyrics PAULINE DEPIENT Music SOL P. LEVY

**MARRIAGE BLUES**  
Lyrics CARL WILDER Music JOS. SAMUELS JULIUS ROMANO HERMAN BERNIN

**WIGWAM**  
Lyrics LEON CASSETT Music JOS. SAMUELS

•GOOD•

•BETTER•

•BIG•

•BIGGER•

•BIGGEST•

**BELWIN INC.**  
701 7TH AVE  
NEW YORK

I "WILL" ORDER MEANS "LESS SALES"  
**"GET IT NOW"**



# Watch It Grow



WORDS BY  
WILLIAM LE BARON

MUSIC BY  
VICTOR JACOBI

CHAPPELL & CO., Ltd., New York, Toronto and Melbourne

## EDISON ADVERTISING DEPARTMENT CAPABLY ORGANIZED

Herewith are shown four Edison officials who are connected with the Edison advertising department as announced in The World some time

ago. Joseph B. Gregg is the new advertising manager and has had a wide experience in the printing business, being thoroughly familiar with all branches. For the past six months Mr.

Gregg has been manager of advertising production. Roy T. Burke is now editor of the Edison magazines, "Along Broadway," "Dia-

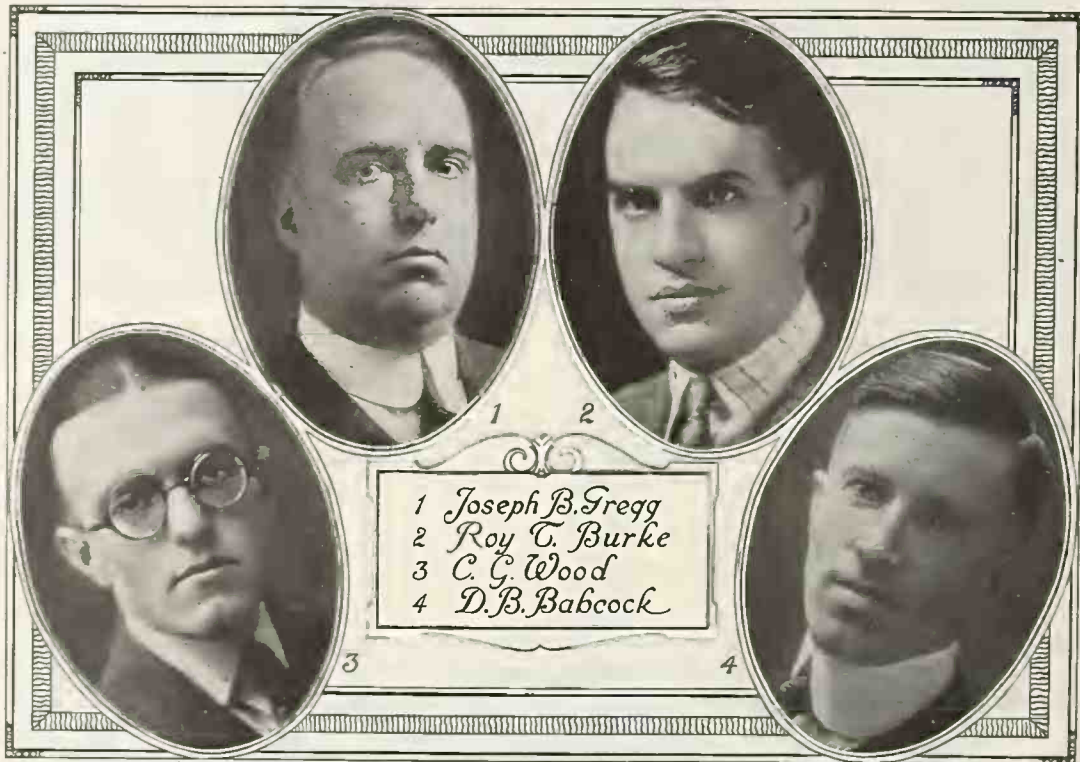

mond Points" and "Amberola Monthly." He will continue in charge of the Edison feature news service, which he originated. He will also have charge of trade paper and other publicity.

mond Points" and "Amberola Monthly." He will continue in charge of the Edison feature news service, which he originated. He will also have charge of trade paper and other publicity.

C. G. Wood, assistant advertising manager, was formerly advertising manager of the Universal Film Exchange. D. B. Babcock, who is an expert on window and store display, has been appointed manager of the dealers' service.

### VICTOR DEALER ORGANIZING BAND

A. M. Sellemeyer, of Holthouse Drug Co., Decatur, Ill., Adopts New Plan for Arousing Greater Interest in Music in His Section

Believing firmly in the advertising benefit that results from associations in musical affairs of the community, A. M. Sellemeyer, manager of the Holthouse Drug Co., Decatur, Ind., is organizing a band. He hopes to perfect an organization that will include all band instruments and will be available for concerts at county fairs and other community celebrations. As leader of the band he will gain recognition as a musical authority, to the distinct advantage of his Victor record business.

Recently Mr. Sellemeyer gave a demonstration of orchestral instruments in the high school auditorium at Decatur, using the instruments of the orchestra, charts and Victor records to demonstrate each instrument.

### SHELDON TALKS ON AUSTRALIA

The More We Buy of Australia the More We Will Sell Her, Declares Trade Commissioner at Exporters' Banquet in New York

American exports to Australia under present trade conditions were discussed by 300 members of the American Manufacturers' Export Association at a luncheon in the Hotel Pennsylvania recently. Mark Sheldon, Trade Commissioner from Australia, was the only speaker. In part, he said:

"In 1913, pre-war, your exports from the United States to Australia were only \$55,000,000. The proportion then was 13½ per cent of our total imports. I have been asked how this compares with Japan. Japan has done \$41,000,000 of trade during this last year ending June 30, 1919, as against \$130,000,000 that represented 11 per cent of our imports.

"Japan has increased her trade very largely, principally in textiles and silks, but I don't think she will hold it. The more you buy from Australia the more you will sell her."

### THE BIG-HEARTED SCHUMANN-HEINK

Many instances have been told of the great mother-heart of Madame Schumann-Heink, the famous contralto and popular Victor artist, but this one from Frank La Forge is worth relating: "It took place in Twin Falls. Madame was giving a recital and we were on the platform, all ready to begin, when she signaled to an attendant to bring a chair. What could she want with a chair? Was she tired? Did she want it to lean on? Was she going to sit down? No, she was not going to sit down. She carried the chair to the edge of the platform and signaled to a woman who sat in the front row beneath, her enraptured face peering from between two solemn babies who nearly smothered her. When she finally understood Madame's kindly intent the chair was set in the aisle, and with the plump babies enthroned thereon the concert proceeded without further interruption."

**3 "CHAMPS" IN A ROW!**

**YOU CAN SELL MORE THAN YOU ORDER!**

**RECORDS      SHEET MUSIC      PLAYER ROLLS**

**JACK CADDIGAN'S UPPERCUT**

**"BLUE DIAMONDS"**

**GENE QUAW'S BODY BLOW**

**"OLD MAN JAZZ"**

**JOE HOWARD'S KNOCKOUT**

**"WHISTLE A SONG"**

**OTHER**      "BLUES" (NAUGHTY SWEETIE)      "ONLY FOOLING ROUND ME"  
**STAR BOUTS**      "YOU DIDN'T WANT ME"      "NOW I KNOW"  
Anatol Friedland's "THANKS"      "ABADELE"

**JOS. W. STERN & CO., 102-104 W. 38th St., N.Y. C.**

**NEEDLES**

WE MANUFACTURE

Diamond needles for Edison  
Sapphire needles for Edison  
Sapphire needles for Pathe

*in stock ready for delivery*

MERMOD & CO., 874 Broadway, N. Y.



# Featuring the MUSICAL POSSIBILITIES of the TALKING MACHINE

[Note:—This is the 45th of a series of articles on the general subject of the musical possibilities of the talking machine by William Braid White. The aim of the series is to develop these possibilities from all angles, thus opening up fields for sales expansion neglected wholly or in part.—EDITOR.]

## POSSIBILITIES OF THE MUSICIAN

It is often true that we neglect the most obvious and nearest sources of success, while we exhaust our endeavors in vain striving after others which lie out of reach. Especially in the business of building demand for any kind of article which requires an educated taste is it true that we very often overlook the most patent of sources for inspiration, encouragement and success, while we give all our attention to others which are not only further distant but in every way less valuable.

So long as business acumen and the habits which go to make up the business man's method are necessary to the conducting of a talking machine selling enterprise—which means forever—there will be a sort of difficulty in bringing together in the one person the opposite ideas which are suggested by the artistic nature of what the machine does and the commercial nature of its position as a thing to be made and sold. The business man often, in fact, will have difficulty in keeping before him the plain fact that he must think and sell "music" rather than furniture. In proportion as he so neglects, however, the foundation of his business will be unsound. In proportion as he keeps this fact in mind, on the contrary, he will find himself strong and secure.

### The Feeble Arts

The influence of the arts on the life of the American people is not indeed very great. The

influence of artists, musical or otherwise, is still smaller. There is a variety of reasons for this condition of affairs. But the facts are beyond dispute. In the case of the musical industries, and especially in that of the talking machine, there has been a remarkable example of this. Although the talking machine business has been built up mainly on the prestige of the great singers and instrumentalists who have furnished the records, the influence they have had has been confined to this function. Yet it should be plain enough that every musician in the world is normally in a position to co-operate with the talking machine in the most effective manner.

Now in fact the rank and file of the musical profession is doing little or nothing to advance the cause of the talking machine, although the latter is doing a great deal to advance the cause of music. Great internationally known musicians have been and are the public friends of the talking machine. Yet the local singer or player, the local teacher of piano, violin or singing, is usually either indifferent or negative in attitude.

### The Local Musician

Yet it is surely plain that the local musician in each community, the piano, violin or voice teacher, organist or band leader, has the closest possible interest in the progress of the talking machine. No such musician can say that the talking machine has ever done him any harm. In fact, of course, it is the talking machine which has done more than any other agency to preach to the masses of the people the gospel of good music. The voices and the arias of great singers, the technic and the tone of great violinists, have been brought to thousands who would never have heard them otherwise. The

musician who has to make a living in the ordinary community by the ordinary process of teaching some practical branch of music ought rightly to be in continuous and most fruitful contact with the talking machine dealer.

Yet somehow or another one very seldom finds a dealer who has managed to make and maintain any such contact. How is this? Certainly the dealer who has been unable or unwilling in this respect has been neglecting business opportunities of the most valuable kind.

Now it seems to me that it is worth while—emphatically worth while—to go out after the friendship of every person who teaches any practical branch of musical art. In the first place such persons have a great deal of influence, often more indirect than direct, in forming the taste of the society in their community. It has often been pointed out that the best foundation of a music business lies in the cultivated taste of a community. Given this taste and the merchant may be sure that he will not suffer from the uncertainties of public caprice. Good musical taste does not alter or fluctuate. The high-class records sell year after year steadily. They are bought by men and women to whom each new acquisition stimulates the appetite for more. It is simple commonsense to see that the cultivation and improvement of this taste in every way forms one of the most important duties of the talking machine merchant.

### Bringing It to Them

And it should be cultivated through the agency of the musical profession in the community. If I were a merchant I should try to make it unusually easy for musicians to possess talking machines, and I should go to

(Continued on page 205)

## Good Profits and Satisfied Customers

Make Both by Selling This Dependable Victor Accessory

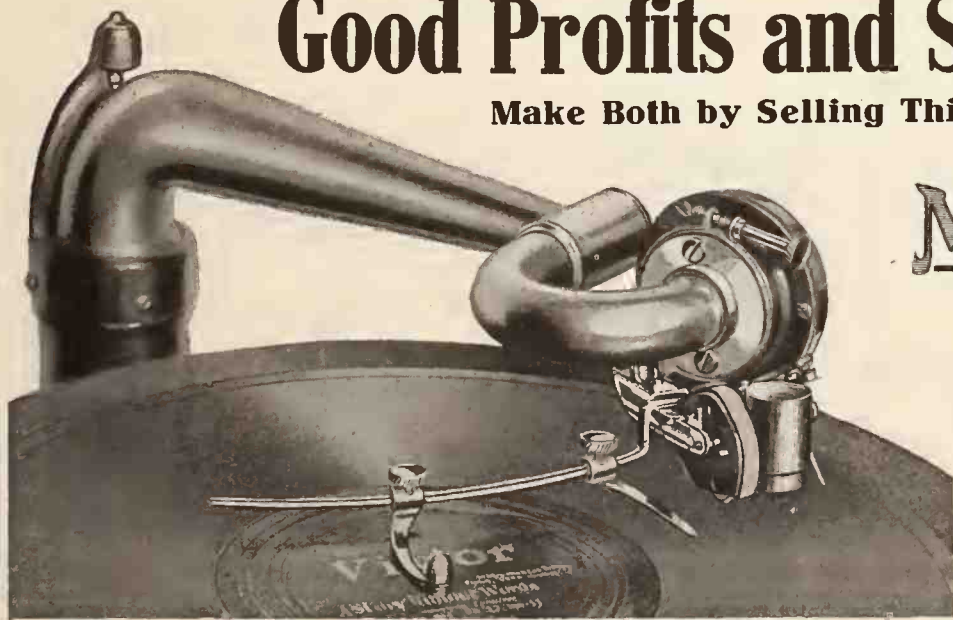

### The Myers Replayer

At last you are offered a replaying device that is not an experiment. Its growing sale is proof that it is a meritorious, dependable Victor accessory. The Myers Replayer is positive in action, though simple in construction.

#### BOOSTS RECORD SALES

The record dealer who equips his demonstrating machines with this device will find that it literally sells itself. He will find, also, that one person can attend to approximately twice the record customers heretofore possible.

### Easily Attached to Any Victrola. Provides Continuous Music for Any Occasion

#### EASY TO ATTACH

One thumb screw does it. Any child can quickly and easily attach The Myers Replayer.

#### AUTOMATIC

The Myers Replayer does exactly what its name implies—replays a record without interfering in any way with the usual operation of the machine. It does not deface or injure any mechanical part or the ornamental ap-

pearance of the machine. Attaches to the tone arm only, and with a single thumb screw.

#### PRACTICAL

Once The Myers Replayer has been properly adjusted and attached, no further attention is necessary. No need to disassemble or remove when changing records. Instantly adjusted for non-operation.

#### IMPOSSIBLE TO DAMAGE RECORDS

The Myers Replayer is equipped with a

patented air-cushion dash-pot which returns needle to record with the deftness and ease of the human fingers. This protects the needle point and prevents the defacing of the record.

#### USES ANY LENGTH NEEDLE

Any style or length of needle can be successfully used with The Myers Replayer without special adjustment or changing height of Replayer attachment.

All parts nickel plated and highly polished to correspond with similarly finished parts of machine

Present model made only for Victor Machines. Models for other machines now under construction. Dealers are requested to watch for future announcements.

Retail price \$5.00. Quickly pays for itself in the increased pleasure it brings. Sample for dealers sent post-paid for \$3.00. Send for sample. Begin now to Boost Your Accessory Profits.

**The Myers Replayer Co., Dept 184 Toledo, Ohio, U. S. A.**





# THE ELECTRIC AGE

## *Comes to the Phonograph Industry*

**T**HE electrical industry has surpassed all others in the process of commercializing its inventions and adapting them to the immediate practical needs of the world.

Electrical devices have revolutionized modern life and have made even the preceding generation seem incredibly old-fashioned.

*Roberts*  
ELECTRIC  
PHONOGRAPH  
MOTOR

took its place in the electrical industry three and a half years ago. Since then it has amply demonstrated its worth in all imaginable circumstances. Its users unite to proclaim it the best electric phonograph motor which has yet appeared, and we intend to keep it always at the head of the procession.

The Roberts stays sold. Not only so, but it is every day yielding satisfaction and genuine pleasure to thousands of progressive believers in the electrical age.

Each day shows an increase in the number of electric phonograph motors in use. The electric age in phonographs is here. Wherefore it is even more necessary to stress the fact that the ROBERTS is THE electric phonograph motor par excellence, not only for the new phonographs now in process of manufacture, but to fill the already great and rapidly increasing demand for a reliable electric unit to replace existing spring motors in the home.

**Chicago Metal Products Co.**

*Manufacturers*

426 South Clinton Street  
CHICAGO

**Moeller-Waters, Inc.**

*Sole Selling Agents*

Lyon & Healy Building  
CHICAGO



**POSSIBILITIES OF THE TALKER**

(Continued from page 203)

unusual trouble to see that they obtained all the best records, or at least as many as they could afford to buy. There are several methods to this end which will suggest themselves to the merchant. I should, if I were a merchant, see that each and every musician in my community was supplied with information on all the records connected with his or her own special line of music. I should see that invitations were sent periodically to these men and women to hear the records in which they would most likely be interested. I should try the experiment of offering "private views," or rather "auditions" of the latest high-class music to musicians on the mailing list; specifying that these were advance affairs specially arranged before the records were put on sale. I should, in fact, do everything I could to make it easy for each musician to become acquainted with the whole library of fine music at my disposal, and I should constantly emphasize the fact that these are an aid in the study as well as in the appreciation of music.

**The Result**

And what would be the result? Simply that the talking machine would be talked about by every cultivated man and woman in the community. It would be preached steadily by every musician, and in consequence there would be no knockers and no sneers. Once get the musicians to using it and there would be no trouble in selling it wherever their influence might range. And that means wherever refinement and culture are to be found.

It is strange that the talking machine business should have been unable to establish fruitful contact with the musical profession in the general run of communities. Yet the explanation is to be found in the persistent failure of American business men to see that the arts are to be taken seriously or that musicians are really flesh and blood individuals with normal thoughts and actions. To this day we find that

the old Puritan idea of the artist as probably in some way a vaguely undesirable person in the relations of daily life persists awkwardly. Many men who think themselves very clear-minded are still tainted with old-time superstitions on that point. It is time to have done with all this nonsense and to realize that a musician is not a freak or a sissy. The talking machine business has been running along very fast during the last year or two, and its course has been directed along lines of least resistance. But the day will come when the business

will need behind it all the community taste and all the educated demand it can find. Then those merchants who have developed the musical side of the talking machine by developing contact with the musicians of their communities will find that they are on the right side of the fence. The others will find something very different.

There are many ways of developing the musical possibilities of the talking machine. To develop the talking machine possibilities of the musician is one of them.

**DORIAN LEAVES THE COLUMBIA**

General Auditor to Practice Law in Washington  
—Widely Known in Talking Machine Industry—James J. Munro Named as Successor

H. L. Willson, general manager of the Columbia Graphophone Co., announced this week



Marion Dorian

that Marion Dorian, general auditor of the company, had voluntarily severed his association

with the Columbia organization to take up the practice of law in Washington, D. C. Mr. Dorian's resignation takes effect on April 15.

James J. Munro has been appointed Mr. Dorian's successor as general auditor of the company. Mr. Munro has had long experience in public and private work which eminently fits him for the position to which he has been assigned.

E. O. Rockwood, who for a number of years has handled the general credit department of the company in the auditor's office, will assume the duties of general credit manager, independent of the audit department.

In the official notification to the Columbia organization, Mr. Willson paid the following well-deserved tribute to Mr. Dorian, who is one of the most popular members of the industry:

"It is with conflicting feelings that this announcement is made, for the reason that while we are losing the services of a good friend and a conscientious, loyal and competent associate, Mr. Dorian's undertaking in Washington is the attainment of years of anticipation, and will enable him to pursue the vocation which, under the circumstances, is most to his liking. Mr. Dorian has been continuously associated with the company for more than twenty-three years, occupying important positions in Europe and America, and has done much toward the improvement and perfection of our organization. He leaves the company with the heartiest good wishes for his success and happiness."

**NOTE THE CONSTRUCTION!**

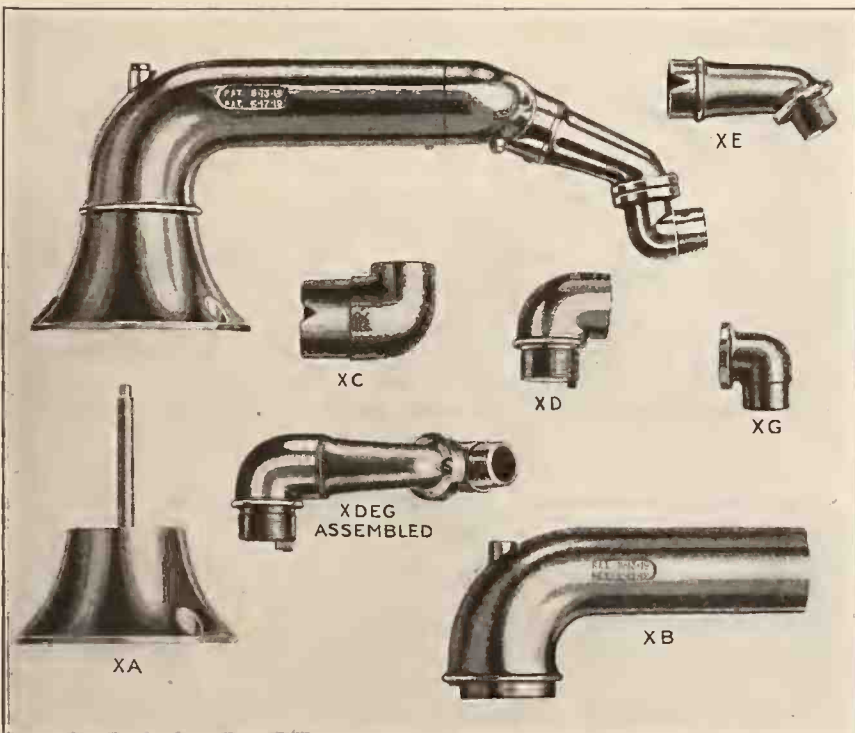

**UNIVERSAL TONE ARM AND REPRODUCER**

*Do You Realize That One of the Most Important Items of Equipment on Any Phonograph Is the Sound Reproducing Mechanism?*

The saving of a few cents on the first cost of this important item of equipment is very poor policy, especially for any firm desiring to build up a profitable and permanent phonograph business.

The EMPIRE TONE ARM AND SOUND BOX is more nearly PERFECT mechanically than any other. On performance it will reproduce all makes of disc records at their best and bring out all the beautiful overtones that are usually lost. On appearance it will appeal to your dealer customer and help him interest the best of trade.

*Write for our prices and give us an outline of the quantities you will require*

Address All Inquiries to Chicago Office  
**THE EMPIRE PHONO PARTS CO.**

Sales Office—429 S. Wabash Ave.—CHICAGO, ILL.  
Factory—1108 W. 9th St. — CLEVELAND, OHIO



---

---

# “T. M. W. S.” has made good—

---

---

Don't take our word for it—*read what the dealers say who use it!*

When we say that the Talking Machine World Service for Retail Dealers supplies you with the best advertising matter, cuts for ads, window display plans, form letters and merchandising ideas ever put on the market—don't take our word for it. Look at the opposite page. *Read what the users say!*

If the Talking Machine World Service is making a big profit for them, *it will do the same for you.*

One dealer said, “The only thing I'm sorry about is that I didn't get hold of your Service six months ago. I saw your ads in the **WORLD** but I didn't realize what a fine proposition you had, *and I didn't send in a coupon.*”

### *Talking Machine World Service Means—*

—a syndicated advertising and merchandising service. It means the reading matter for your advertising written by men who have spent a lifetime learning how to prepare ads that can and do sell talking machines and records.

It means illustrations for your advertising—the best product of famous magazine artists, cartoonists and designers—the kind of work that has charm and human appeal, along with the punch.

It means prepared layouts for your advertising that stand right up on the printed page and talk out loud.

It means merchandising ideas, plans for window displays, form letters that bring results—a new set each month, every month, twelve months in the year, and with special attention to your own problems about which you write us.

---

---



# and here's the evidence:

These testimonials prove beyond question that we can earn money for you; that we know how to sell merchandise for you, and build up your store, your name and your reputation.

Every testimonial is guaranteed to be a verbatim extract from original correspondence with our clients, the original being on file in each case in our New York office. It is open for inspection at any time.

### From New Jersey Clients:

1. "We received the special letter on moving, also the car card copy, and think both are clever and are just what we wanted. The letter is being mimeographed on our letterheads and we expect to cover our mailing list with it shortly. Thanking you for your efforts in our behalf, we remain, etc."

2. "We think the Service is Bully."

3. "Received the April Service to-day. Majority of contents valuable for Easter advertising."

### From New York Clients:

4. "In reply to your letter of 27th ult., would say that we received the copy for the fine newspaper advertisements which you got out for us pertaining to our exhibit at the New York State Fair. We will send you copies of these advertisements as soon as they appear in the newspapers. We wish to commend you on your splendid monthly service, and thank you for your co-operation."

5. "Your ads and letters speak for themselves."

6. "We are enclosing you herewith a page from one of our local newspapers containing a.....advertisement that you got out special for us. Without a doubt we think this is the most wonderful.....advertisement ever written."

7. "Bully."

8. "Your Thanksgiving ad is the best ever. Also your coupon idea is good and we like your quotation 'Not on the Main Street, but the Main Store.'"

9. "We find that our phonograph and piano business has grown to nearly three times what it was last year since using your Service."

10. "Your letters and ads are sure to be winners and I believe will bring results."

11. "Greatest thing in the world for this line of business."

12. "Bully."

13. "We think your service is great and are using it to the limit."

### From Massachusetts Clients:

14. "We are very much pleased with the Service we are getting from you people."

15. "The circular letter is a wonder."

16. "If memory serves us—we are contracted with you for some ten of our different branches and what we have heard from the various sales managers, they are all as pleased as we are. It is the fresh viewpoint—plus excellent cut service—which makes the matter so desirable. It will be our pleasure to write each one of our managers, who use the service, to express to you direct his own opinion and appreciation of it."

17. "Most of the drawings are certainly excellent."

18. "Think that your ad featuring all machines in one store very good."

19. "They (the ads) are right to the point."

20. "Think your suggestion for single column ads during Summer months is very good."

21. "Have just been looking over the Talking Machine World Service for March, which has just reached us, and it seems to me that their stuff is full of pep. In the merchandising ideas there is one item that might have been

written expressly for us and that is the paragraph referring to the advantages of a fourth floor salesroom. You know we are the only upstairs place in....."

22. "We are very well satisfied indeed with your talking machine advertising service to date. Your last presentation of matter is—in our minds—the best yet—this not excepting the very fine Christmas presentation."

23. "We are hearing nothing but praise for the Talking Machine World Service—advertising manager says it is the best thing of the kind he has ever seen."

24. "Mighty fine."

### From Connecticut Clients:

25. "We are very much attracted by the Proclamation ad for Thanksgiving and let us say the ads and letters are all good."

26. "We like the witty little ads, brief and to the point."

### From Pennsylvania Clients:

27. "Very good."

28. "I think your suggested letter for April is a dandy—am using it."

29. "We are very well pleased with your Service. It has a real 'punch' and 'pep.' Cuts are most desirable. The cuts and ads for St. Patrick's Day look like real 'business getters.'"

30. "Mighty well pleased with cut list for April."

31. "Last month we received the World Service for Retail Dealers, and were very well pleased with it, in fact we used it and obtained direct results, and we have been looking forward to the Service for October."

32. "Great stuff—and it is certainly helping. I have run it continuously since signing the contract with you, and business is picking up all the time."

33. "Our very first ad brought a \$150 sale in less than three hours."

34. "I think this month's ads and letters are splendid."

35. "Very good."

36. "R.D. 111—R.D. 110 because appeals to whole family. R.D. 111 because it's full of pep. R.D. 35 is the most attractive ad."

37. "Ads this month are real snappy. They should sell records."

### From California Clients:

38. "Very good."

### From Ohio Clients:

39. "Best ever—keep up this steady and obvious growth—your cuts are so decidedly different that they take away that commercial tenor found in so many ads."

40. "Although we may not send you the World ads at all times, we nevertheless use them all each month and are pleased with the general idea incorporated in them and the unusually attractive art work."

41. "I know we have gotten better results from the Service than the ads we used before. My actual experience has made me a booster (for the Service) of the 100 per cent type."

42. "Your ads are fine this month."

43. "Your Service is indeed complete. I intend using it extensively."

44. "As we are the largest exclusive..... advertiser in the country, who, although a virtual department store chain, run phonograph advertising entirely exclusive of our general advertising, we feel that we are competent to judge the value of your service and actually feel it of great need, particularly to the smaller dealers sometimes lacking in facilities for proper merchandising along modern lines. Thanking you for your past service in this respect and offering our co-operation at any time we can assist you in furthering the World Service, we are, etc."

### From Michigan Clients:

45. "Cuts are very good. So good in fact that I want them all. Keep up the good work."

### From Kansas Clients:

46. "We have your letter of January 10th at hand, and wish to say that we appreciate to the fullest extent the splendid co-operation which you give and the class of advertising which you are producing. Business is growing better with us every day and you can say for us to any one interested in high class, up-to-date advertising, that it is our candid opinion, that there is nothing better. It surely gets the business. We note that you are going to line up a little ad for us, and will be glad to receive same as soon as you have it ready."

### From Arizona Clients:

47. "Very well pleased with both (ads and cuts)."

### From Maine Clients:

48. "The ads this month are so darn good that we couldn't resist ordering all of 'em and what's more we will use 'em too. Snappiest stuff we ever saw."

### From Kentucky Clients:

49. "Great."

### From Washington Clients:

50. Re November Service—"Better than October."

### From Tennessee Clients:

51. "There is no denying that the service you have featured for February is wonderful and we expect to use same with big results."

### From Canada Clients:

52. "Your Service is real all right and we are going to use you until you holler 'Give us a breath.'"

## Here's the first step towards big success

**COUPON**  
 TEAR OFF—FILL IN—MAIL TO-DAY

**Talking Machine World Service**  
 373 4th Ave., New York

If your service can earn money for me, bring big results and save my time, I want to see it. Send samples and full information, without obligation on my part. What will it cost per month for exclusive use in my territory?

Population of my city is.....  
 I handle these instruments.....  
 My firm name is.....  
 By .....  
 Address .....

4-15-20



## LOS ANGELES REPORTS BIG TRADE VOLUME

First Quarter of the Present Year Shows Large Gains—New Aeolian-Vocalion Officials Visit Los Angeles—Gathering of Columbia Forces—Managerial and Sales Force Changes—Other News of Travelers and Coast Visitors

LOS ANGELES, CAL., April 1.—The reports from the various dealers in the city of Los Angeles agree in the verdict that March has been the fitting close to the excellent first quarter of this year and shows a very large increase over that of 1919. Some of the big houses claim that March sales in the aggregate exceeded those of any previous month in their history, with the exception of sales for the Christmas holiday months. The southern California dealers outside of Los Angeles are equally enthusiastic and from all parts of the country report exceptionally fine business. The visit of Aeolian officials with the resultant appointment of representative dealers in Los Angeles ushers in a new competitor in the phonograph field on the Pacific Coast.

### Association Meets

The Music Trades Association of southern California met last month and discussed several important subjects pertaining to the talking machine industry. The meeting took place in the Fitzgerald Music Co.'s store.

### Aeolian-Vocalion Officials Here

Sales Manager Alfring and H. M. Hull, of the Aeolian Co., were recent visitors in Los Angeles. H. M. Hull is to take charge of the Pacific Coast branch in San Francisco for the present. Further developments will probably take place later. It was understood that three dealers would be appointed to handle the Aeolian-Vocalion in Los Angeles.

### Columbia Branch Holds Meeting

A very attractive meeting for Columbia dealers was arranged by L. C. Ackley, city salesman, and was held in the Alexandria Hotel. The April records were first of all played to the dealers and then a model sale was demonstrated by Traveler Mack, Columbia dealer; Elliot, of Long Beach, being the buyer.

### New Assistant Manager at Barker Bros.

Captain Walter M. Mann, formerly of the U. S. Army and a member of the American Military Mission to Berlin, has been appointed by General Manager Boothe of the music department of Barker Bros. as his assistant. Captain Mann is exceptionally well qualified for his new position.

Emerson Artist Makes Hit in San Francisco Phil Baker, piano-accordion player and Emerson artist, member of the well-known Palace Trio, made a decided hit at the Orpheum in



FULTON (Model 35)

Mahogany, 16x16x10 in., double spring motor, universal tone arm. Back casting and metal horn. Discount according to quantities.

(Model 50) With Cover

Mahogany, 17x19x13 in., double spring motor, Universal Tone-arm.

Truc-tone and Clear-tone Needles, in metal boxes or packages at 50 cents per M.

Universal double and triple spring Motors, Tone-arm, Auto Stops, etc. Phono parts and accessories, as Motors, Tone-arms, Sound Boxes, Cabinets and Cabinet hardware. Repair parts for all makes.

Records—Standard make, lateral cut, at \$40.00 per 100.

Cash with order

**FULTON TALKING MACHINE CO.**

640 Broadway New York, N. Y.

## Do You Throw Money Away?

It is not a popular pastime—but still it is unconsciously done by many who just don't know that *Repair Parts* can be bought for less

**RENE MADE SPRINGS AND PARTS LAST LONGER  
COST LESS**

**RENE MFG. CO.**

**Montvale, N. J.**

San Francisco, declares I. Lesser. The latter recently visited San Francisco in the interests of his firm, the Western Jobbing & Trading Co., of this city, and stayed there for ten days visiting the trade. Phil Baker will appear at the Orpheum here during the second week in April. Barnes Music Co. to Remodel  
Extensive alterations have been commenced

on the first floor of the Barnes Music Co. This will involve an entire remodeling of the phonograph department and will enable the salespeople to handle the increased trade advantageously.

Fuller & Sunderland Aeolian Dealers

Fuller & Sunderland, of the Broadway Department Store, have obtained a dealer's agency

## AMERICAN

THE AMERICAN success has been gained through merit. It is a truly musical machine, and, owing to its excellent equipment, will enable your trade to enjoy every record to its full extent.

Seven models, mahogany, golden oak and fumed oak finishes. The AMERICAN remains sold when delivered. Grand Rapids made and guaranteed throughout. Meisselbach equipment. Are in position to make prompt deliveries and place but one dealer in a town.

Write for our 1920 catalog. Handle a line that it is a pleasure to sell and which carries with it a good profit.

**American Phonograph Co.**

17 N. Ionia Ave., Grand Rapids, Mich.



No. 5  
Height—40 in.  
Width—17½ in.  
Depth—18½ in.



No. 8  
Height—43 in.  
Width—19 in.  
Depth—20 in.



No. 9  
Height—45 in.  
Width—20 in.  
Depth—21 in.



No. 10  
Height—48 in.  
Width—20½ in.  
Depth—22 in.



No. 11  
Height—51 in.  
Width—23 in.  
Depth—24 in.



No. 14  
Height—46½ in.  
Width—19½ in.  
Depth—20½ in.



No. 22  
Height—50 in.  
Width—22 in.  
Depth—23½ in.



# CHAS. H. YATES

311 Laughlin Bldg. Los Angeles, Cal.  
Manufacturers' Distributors of High  
Grade Phonograph Accessories and Supplies.

- |                                 |                             |
|---------------------------------|-----------------------------|
| Sterling Reproducers            | Uniform Steel Needles       |
| Tone Arms and Attachments       | Liberty Stylus              |
| Kent Attachments                | Wall Kame Needles           |
| Resurrectone Reproducers        | Sapphire and Diamond Points |
| Ready Files                     | Fibre Needles               |
| Ward's Moving Covers            | Wade Needle Cutters         |
| Fearless Albums                 | Record Brushes              |
| Record Envelopes                | Tone Clear                  |
| Globe Transfers and Name Plates |                             |

## AND JONES-MOTROLAS

for the Aeolian-Vocalion. The initial order for immediate delivery amounted to several thousand dollars and included at least two each of every art model. D. G. Sunderland declared that his firm are exceedingly gratified at their success in obtaining the Aeolian-Vocalion agency. They have had experience with the line in the East and had always looked forward to the opportunity of handling it in their Los Angeles department.

### P. H. Beck Leaves Los Angeles

P. H. Beck, manager of the talking machine department of the Platt Music Co., has resigned his position in order to assume the management of a similar department with Byron Mauzy, of San Francisco. Although congratulations are extended by all to Mr. Beck on his new appointment, his loss to Los Angeles will be very much felt. He has always been very popular and was president of the Talking Machine Men's Association for one year and the present Music Trades Association of Southern California owes much to his efforts and help. Walter Evans, of the piano department of the Platt Co., will succeed Mr. Beck in the management of the talking machine department.

### New Columbia Salesman

Owing to the resignation of Newton I. Hancock, of the local branch of the Columbia Co., a vacancy in the sales force has been created. This will be filled by Frank Newman, who will

commence his new duties in Arizona. Mr. Newman is particularly well qualified to travel and visit Columbia dealers. He is not only a proficient salesman, but an expert mechanic and consequently in a position to explain the best points of Columbia motors and the popular automatic non-set stop.

### March Beats All Former Records

Excepting the months of December, 1918 and 1919, the total sales for March exceeded those of any previous month in the history of the music department of Barker Bros., according to J. W. Boothe, general manager.

### Lady Heads Salesforce

There are several cases on record of members of the fair sex becoming managers of talking machine departments, but we believe that the position of sales manager as distinctive from manager has never been filled by a lady before. Miss Dorothy Darling is sales manager or head sales person for Fuller & Sunderland at the Broadway department store. She has a number of salesmen (mere males) under her and the results and figures from month to month speak eloquently of her ability and skill. Miss Darling is heart and soul in her work and owes her present post to her untiring devotion to duty, added to her charming personality.

### Nora Bayes in Town

Nora Bayes, in her new musical comedy, "Ladies First," is at the Mason, and Nora is "packing 'em in" in her usual fashion. Among other songs she is singing "Freckles" and "Just Like a Gypsy," records for the Columbia Co.

Cowan Piano & Music Co., Montreal, are enlarging their "His Master's Voice" record department to carry double their former stock of records. A larger stock of Brunswick phonographs will also be carried.

The owner of a large new apartment house in Chicago, Ill., it is said, is providing a phonograph and set of records as part of the furnishings of each apartment.

# BEE CROFT

## Delivery Envelopes Art Series—New Designs NEW LIST OF RECORDS

# Every 60 Days

### A Selected List of Victor Records



We Will Be Pleased to Play Any of Them for You

18600-10	Dear Heart	Bliss	4:45
18600-11	Oh! What a Pal and Mary	Bliss	4:45
18213-10	When the Angel Blows	Victor	3:30
18213-11	Yellow Chrysanthemum	Victor	3:30
18213-12	New York Humorous Madly	Victor	3:30
18213-13	Victor Band	Victor	3:30
18213-14	The Mellow Humors (Best)	Victor	3:30
18213-15	Victor Orchestra Chorus	Victor	3:30
18213-16	Victor Phonograph Chorus	Victor	3:30
18213-17	Victor Male Chorus	Victor	3:30
18213-18	So Long, Long, Hello! Pat You	Victor	3:30
18213-19	Your Victory Band	Victor	3:30
18213-20	Victor Band	Victor	3:30
18213-21	Edith in a Nursery in the Zoo	Victor	3:30
18213-22	Victor Band	Victor	3:30
18213-23	Victor Band	Victor	3:30
18213-24	Victor Band	Victor	3:30
18213-25	Victor Band	Victor	3:30
18213-26	Victor Band	Victor	3:30
18213-27	Victor Band	Victor	3:30
18213-28	Victor Band	Victor	3:30
18213-29	Victor Band	Victor	3:30
18213-30	Victor Band	Victor	3:30

# PHONOGRAPH CASES

Reinforced 3 ply veneer  
**THE STANDARD CASE**  
for Talking Machine and Records



Made by

## PLYWOOD CORPORATION

GOLDSBORO, N. C.  
Mills in Va., N. C., and S. C.  
Chicago Office, 111 Monroe St.

## and Plywood Cases

ARE SYNONYMOUS

For 10 years phonographs have traveled in plywood cases and have reached destination in perfect condition.

Our capacity and experience in manufacturing insure your getting good service and well made cases.

Let us figure on your requirements.

Very attractive proposition to Jobbers

Write for trial shipment

**CLEMENT BEECROFT**  
309 W. Susquehanna Ave.  
PHILADELPHIA

### ISSUES NEW STEINBURN FOLDER

A. M. Druckman Distributes Descriptive Matter to the Eastern Trade

A. M. Druckman, 140 East Twenty-third street, New York, Eastern distributor for the Steinburn Corp., Chicago, Ill., manufacturers of the Steinburn line of phonographs, has just forwarded to the trade a new folder describing and illustrating the complete line of Steinburn machines. A special position is given in the folder to the console models. These are very distinctive cabinets in period designs, including Louis XIV and the Adam period. The exclusive equipment of the Steinburn machine is also described and illustrated, and special mention is given the motor.

The back page of the folder is given over to the reproduction of the guarantee bond which is issued with the machine, which gives the buyer protection over a period of five years, and is backed both by the distributor and the manufacturer.



# WADDELL PHONOGRAPHS

*"The Phonograph with a Secret"*

They are DIFFERENT from all other phonographs

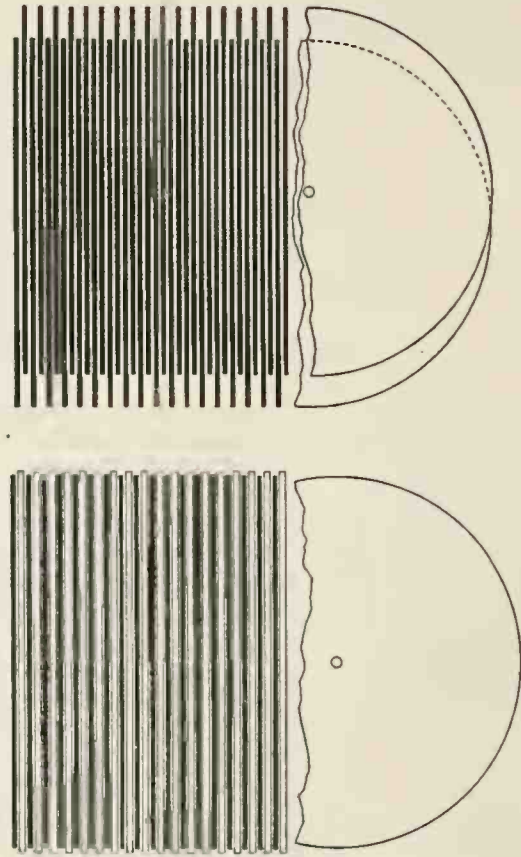
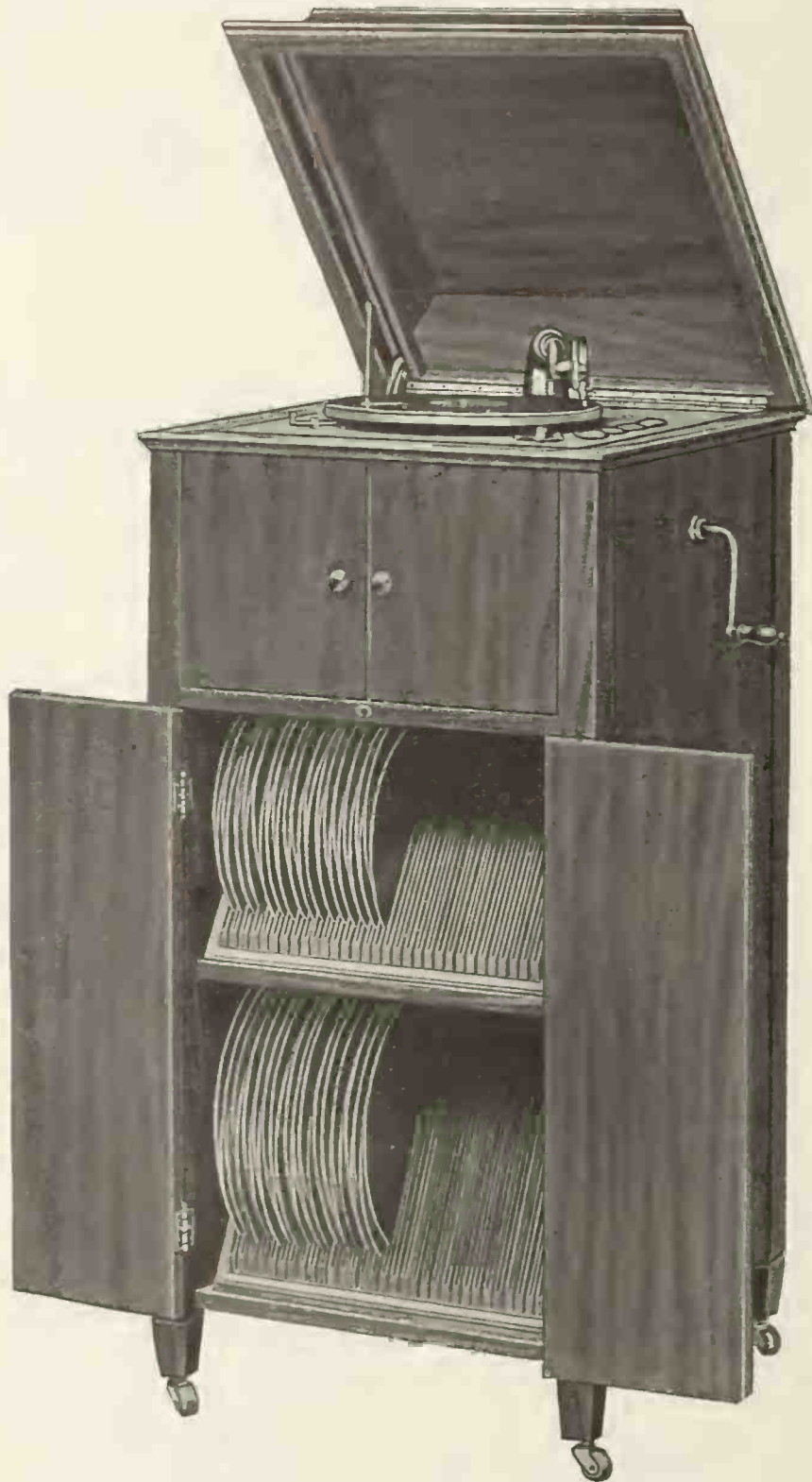

The upper drawing shows Waddell's patent record filing system; the lower drawing shows the old way of filing. The heavy black lines indicate the edges of the records. Note the staggered formation in our patented system, in which we get twice as many records in a given space, and permit just as much room for the thumb and finger. This system is used only in Waddell phonographs.

## Selling Features, only FIVE, but all good

1. Record Filing Systems are usually conspicuous by their inefficiency; ours by its superlative efficiency. Capacity, 256 selections, each record instantly accessible; every filing space numbered, sticker numerals for both sides of record and a card index furnished. Each record separately filed with partition between, keeping them in perfect condition. A wonderful feature, patented, and to be had only in Waddell phonographs.

2. And then, the Automatic Balanced Lid, working in

conjunction with the drop shutter, automatically opening and closing the mouth of the amplifying horn, doing it so easily that a three-year-old child may operate it with ease and without danger of the lid falling on its fingers. Covered by our patents. A feature with a great leverage on the selling end.

3. Tone. A much abused word. Nevertheless, we have it in that rich, colorful fullness that reveals hidden treasures in that favorite record of yours. No wonder it is called "The Phonograph With a Secret." The most important of all selling features.

4. Cabinet Work and Finishing. Thirty years' experience to back up our desire to give the best value in the talking machine field. Designs plain, but of surpassing elegance that can only be had by painstaking work. Best materials throughout. A great selling feature is a beautifully finished cabinet. Waddell phonographs excel in finish.

5. Packing. "Aye, there's the rub," but not in the packing of Waddell phonographs. We do give ATTENTION to packing, lots of it, and it's a pleasure to unpack Waddell phonographs and to note the unusual care taken to insure receipt in an unmarred and perfect condition, as we know that to save the dealer annoyance and expense our goods must reach him "in apple-pie order." A splendid feature, don't you think?

Waddell Phonographs have individuality and character. Made in four sizes and styles—the Music Cabinet No. 1 and No. 2, the Music Table and the Music Stand

Now ready: "Buying a Phonograph—Letters to Jim from Dad"  
Write for the Booklet

MANUFACTURED ONLY BY  
**THE MUSIC TABLE COMPANY**  
GREENFIELD, OHIO, U. S. A.



# Announcement

**S**ONORA PHONOGRAPH PRODUCTS will be distributed direct to the Dealers in *Oregon, Washington, Idaho*, and not through a Sub-distributor, as formerly.

Applications for Dealers' Agencies may be made direct to this office.

## THE MAGNAVOX CO.

2701-2765 East 14th Street  
Oakland, Cal.

*Phonograph Division:*  
616 MISSION STREET, SAN FRANCISCO, CAL.

Manufacturers of "The Magnavox," Loud Speaking Apparatus, Anti-Noise Telephone and Wireless Amplifier

### TALKING MACHINE MEN'S FROLIC

Local Organization of Talking Machine Retailers Enjoys Elaborate Banquet and Entertainment at the Hotel Pennsylvania

The annual frolic of the Talking Machine Men, Inc., the organization of talking machine dealers in New York, New Jersey and Connecticut, was held at the Hotel Pennsylvania, New York, on Wednesday evening, April 14, and in every particular bore out the promises made by the committee in charge, that the entertainment would surpass all previous efforts. The demand for tickets for a time proved embarrassing, and the result was that the commodious grand ballroom of the hotel was well filled when proceedings started.

The banquet began at 7 o'clock and, between and during the various courses, a number of artists well known in talking machine circles provided entertainment of a high class and interesting caliber, with the guests having the privilege of the dancing floor at intervals during the dinner. Among those who helped to entertain were: The All Star Trio, several singers, present through the courtesy of Leo Feist, Inc.; Elsie Baker, Emory B. Randolph, Israel Fein, violinist; Misses Burns and Sheppard, Al Bernard, Selvin's Novelty Orchestra, the Landauettes, an orchestra composed of salesmen from the Landau Stores in Wilkes-Barre and Hazelton, Pa., as well as several other artists not on the fixed program.

### A Period "Tone Arm"

From those manufacturers who several months hence will be in a position to use a high-grade tone arm and sound box of original design and of superior features, **WE INVITE CORRESPONDENCE.** Visitors to New York are also cordially invited to our New York offices. Samples of this new arm will be forwarded to the trade shortly after May 15th, and deliveries in quantities will follow in thirty days from that period.

PERIOD TONE ARM CORP.

55-61 W. 17th Street, New York Chelsea 4744

The floor was given over to dancing exclusively shortly before midnight, and the disciples of Terpsichore made merry until it was acknowledged to be quite late, even by the new Daylight Saving time. Full credit is due the committee for the excellence of the arrangements. Those in charge of the frolic were: John J. Hunt, chairman; J. J. Davin, who has contributed so much to previous affairs; Alfred Galuchie, C. B. Riddle, Irwin Kurtz, M. W. Gibbons and E. G. Brown, secretary of the organization.

### INCORPORATE TO MAKE PANELS

MEMPHIS, TENN., April 7.—The Memphis Plywood Corp., of this city, has been incorporated with a capital of \$100,000, to manufacture panels made from rotary gum veneers. A concrete and steel factory will be ready for occupancy in July, and the company has a number of distinctive features, including the use of waterproof glue, which will be incorporated in its product.

### A. E. GOODMAN NOW MANAGER

A. E. Goodman has assumed the management of the phonograph department of Chas. E. Austin & Co., Chatham, Ont., which firm features in that department the Pathé exclusively.

### M. L. BORIS IN NEW COMPANY

M. L. Boris, well known in the talking machine trade, has been elected president and general manager of the Period Tone Arm Corp., which was recently incorporated under the laws of New York State. This company will manufacture a complete line of tone arms, sound boxes and attachments, and headquarters have been established at 55 West Seventeenth street, New York.

M. L. Boris is one of the "veterans" of the talking machine industry, having been associated with the Columbia Graphophone Co. for many years. He is familiar with every phase of the technical production of tone arms and sound boxes, and according to his present plans several interesting features will be embodied in the tone arms manufactured by the Period Tone Arm Corp. Considerable attention will also be given to the production of sound boxes.

### TO SUPPRESS FALSE ADVERTISING

The British Association of Gramophone and Musical Instrument Manufacturers and Dealers, it is understood, is contemplating energetic action in the matter of suppressing fraudulent trading and fraudulent advertising.

## "MAGNET" DECALCOMANIE NAMEPLATES

**FOR TALKING MACHINE CABINETS ETC.**



From the  
**DORAN CO.**  
45 MICHIGAN AVE  
DETROIT

SOLD BY  
**HURTEAU, WILLIAMS & CO. LTD.**  
MONTREAL — OTTAWA



— FROM —  
**THE PHONOGRAPH CO.**  
1240 HURON ROAD (Second Floor)  
PHONES — PROSPECT 2140 — CENT 1406  
— CLEVELAND —

Pamphlets with fac-simile illustrations and prices mailed on request.



**Kabel Piano Co.**  
SOLE IMPORTERS

**SMITH-SCHIFFLIN CO.**  
126 Liberty Street New York City

SOLD BY  
**WALTER D. MOSES & CO.**  
Oldest Music House in VA and N.C.  
103 E BROAD STREET  
RICHMOND, VA.

SOLD BY  
**J. E. STRATFORD**  
— AUGUSTA, GA. —



## GREAT RECORD DEMAND IN KANSAS CITY TRADE

Difficult to Secure Stock to Meet Demands—  
Better Shipments Coming—Steinola's New  
Quarters—Portola Output Grows—Other News

KANSAS CITY, Mo., April 6.—The month of March was the heaviest record month in this city for many years, according to the talking machine dealers, and yet the month was generally of such weather that the majority of the people found the outdoors greatly to their liking. The month of April, however, has set off in just the opposite style. The first three days of the month brought an exceedingly heavy snow storm, which threatens the success of many of the crops in the agricultural region of this locality, especially in the fruit growing sections where trees were already in bloom. That this will later have an effect upon the financial condition of the territory is beyond question.

Most all of the jobbing houses in the city report that they are now getting in much better condition to take care of the trade, especially in regard to record stocks. Delayed shipments from the East and some from Chicago handicapped the jobbers and dealers alike during the past month. It is a fact that the dealers are not well stocked in the talking machine industry in either machines or accessories. However, this is being overcome as rapidly as possible, although there seems to be no apparent lull in the demand.

The Schmelzer Arms Co. report a general improvement in conditions, particularly as they affect the delivery of machines and records from the Victor factory. Shipments are still considerably behind the demand, but a steady gain is being made, proof of which is found in the greater contentment that prevails among the dealers. The increased and improved facilities which will be enjoyed by the Schmelzer Arms Co. when they occupy their new building this Spring are being depended upon to take care of any future situation that may develop, even to a 100 per cent increase in business.

Arthur A. Trostler, secretary of the company, who looks after the wholesale talking machine business personally, has returned from a visit to Chicago, New York and Camden, where he attended the meetings of the National Association of Talking Machine Jobbers and also called at the Victor factory. He came back thoroughly optimistic regarding business condi-

ditions generally and particularly the factory situation.

In their new home the company will open a school of salesmanship for the instruction of the members of the sales staffs of their dealers, and perhaps some of the dealers themselves, in the fine art of Red Seal record selling and good business practice. The school will be modeled along the line of the Victor Co.'s school in Camden.

The Steinola Phonograph Co., which has long been in the business in Kansas City, assembling machines under the trade name of Steinola, recently purchased the old Third Regiment Armory for the purpose of converting it into a factory where the company will not only do its assembling, but will also build its own cabinets. The space at 1117 Walnut street, where it has long been located, was subleased, although a business office will be maintained there.

The Acme Phonograph Co., also assemblers

of machines under the trade name of the Acme, recently incorporated. However, soon after the incorporation of the company, which has been in business here for many years, application was made to increase the capital stock of the company.

P. R. North, of the Acme Cabinet Co., which has been making cabinets for the phonograph trade in Kansas City and this immediate territory, announced that his business has been extremely good and that the capacity of his plant had been taxed to turn out the contracts that it had on hand. Mr. North has turned his entire cabinet works over to the construction of phonograph cabinets and has one of the most complete plants in the city.

J. L. Replogle, general field manager of the Vitanola Talking Machine Co., recently visited the trade in Kansas City. Mr. Replogle has been traveling through the Southwest territory for some time and reports that the business there has never been in better shape than it is at the present time, especially through Oklahoma and Texas.

C. E. Dodson, general manager of the Portable Phonograph Co., manufacturers of the Portola, recently announced that the output of the company was being increased to care for the extremely heavy demand. Mr. Dodson said: "We were under more or less of a great handicap in moving to Kansas City from Chicago, but we feel that we have got our plant under way in remarkably short time and that production has built up wonderfully well. At the present time we are making immediate delivery, but are nevertheless drafting plans to increase production to maintain a capacity in proportion to the increase in volume of business."

Allen P. Child, of the National Phonograph Supply Co., recently said: "We have been making deliveries in spite of the shortage of goods which we have been facing and the delay in receipts of shipments." The demand for small portable machines has been heavy, but we have been able to make immediate delivery within eight hours of receipt of order, which is a service which we are making every effort to maintain."

C. V. Bissell, district manager of the Starr Piano Co., declares that the Spring season will be the best season that the business has ever experienced in the talking machine and record business. Mr. Bissell has rearranged his department to take care of the big increase which he declares is no longer a thing to look for-

## PRESERVE PHONOGRAPH RECORDS

WITH A



### "TONAR"

TRADE-MARK

### RECORD BRUSH

*Our special treatment not only removes the dust but lubricates the record so as to bring out the most delicate tone qualities*

*It Not Only Cleans the Records But Preserves the Tone*

RETAIL PRICE, FIFTY CENTS

**PARKS & PARKS, Inc.**

**TROY, N. Y.**

New York Office, C. E. Peabody & Co., 143 Chambers St.



**F**OR every \$5000 Automobile sold there are 500 popular priced cars. Are you confining your efforts to the \$5000 class in the Phonograph business, overlooking entirely the low-priced field? Many are doing this, for the phonograph manufacturers have neglected the low-priced models. The demand for them is tremendous. The "CROSLEY," retailing for \$75, fits right in with any line. Read the specifications and look at the illustration.

The "CROSLEY" Phonograph is a neat and attractive mahogany-finished piece of furniture that will grace and decorate the handsomest home.

It stands 38½" high closed; is 19" deep and 18" wide. Shipping weight, about 80 lbs.

**Distributors and Dealers: Write to-day for our proposition. The discounts will surprise you**

**Crosley Phonograph Co.**

1 Vandalia Ave.

Cincinnati, Ohio



ward to, but one that is already in evidence.

A carload of phonographs consigned to the Brunswick-Balke-Collender Co., 1329 Main street, was recently broken into while standing on the railroad tracks and reports to the police stated that almost the entire carload of machines was stolen. It was evident that the thieves used motor trucks to haul the machines from the tracks. The day following the robbery two of the stolen machines were found in the possession of Thomas Veretta, an Italian, at 534 Harrison avenue. Veretta was arrested and stated that he paid \$95 each for the machines. The city detectives and the special agents of the Missouri Pacific railroad later found thirteen more of the stolen machines unpacked and piled up in the back room of a small unoccupied frame house at 2502 Grand avenue. It is stated that the remaining twenty machines stolen from the car will be found within the next few days.

Manager Hendricks, of the Boice Voice Shop, the large Victor retail establishment, gave the retail talking machine trade its first real party Thursday, April 1. Mr. Hendricks issued invitations to all the retail phonograph and talking machine dealers in Kansas City to a dance at

the Boice Shop. The dance was well attended and retailers had a social evening in good fellowship that was more than remarkable and at the same time it gave Mr. Hendricks an opportunity to show off the establishment to the retailers of the city, and to advantage, too.

The Paul Talking Machine Shop, the smallest and most attractive shop in the West, has been doing an extremely unusual business. The shop, under the direction of Mrs. M. M. Paul, has taken a position in the first rank of talking machine establishments in Kansas City, and its record department is well equipped.

**OTTO HEINEMAN ENJOYING REST**

Otto Heineman, president of the General Phonograph Corp., left New York a few days ago for a two weeks' rest in the Adirondacks. During the past few months Mr. Heineman has been working day and night in order to give his executive attention to many important matters incidental to the company's expansion and growth, and his associates urged him to take a rest and conserve his energies for the coming Spring and Summer activities.

**VICTOR STARS IN CRAWFORDSVILLE**

Reinald Werrenrath and Sophie Braslau to Appear in Concert in That City on April 29 Under the Auspices of Schulz & Schulz

CRAWFORDSVILLE, IND., April 6.—Under the auspices of Schulz & Schulz, Victor dealers of this city, Reinald Werrenrath, Metropolitan baritone, and Sophie Braslau, Metropolitan contralto, will appear in Crawfordsville, April 29, in joint recital.

It is not only the first time that these two artists have sung together on the same program, but it is the first time in the history of music in Indiana that two nationally famous musicians have sung together.

The tremendous success of both of these artists has aroused great interest in the Crawfordsville program and ticket reservations are being made from all over the State.

The recital is to be held in the auditorium of the new high school building, an immense room capable of seating more than 2,000 people.

The county is being bill-boarded and a heavy newspaper advertising plan has been prepared.

**THE MYSTO NEEDLE—  
CHANGED ONLY ONCE FOR PLAYING TEN RECORDS — AND GUARANTEED**



WE ARE GOING TO PUBLISH A BIG LIST OF MYSTO JOBBERS AND DISTRIBUTORS NEXT MONTH.

EVERY REAL JOBBER SHOULD BE LISTED.

WRITE TO-DAY FOR MONEY-MAKING JOBBERS' ARRANGEMENT.

NEEDLES FURNISHED IN COUNTER DISPLAY STAND JUST LIKE CUT SHOWN—50 NEEDLES IN EACH PACKAGE RETAILING FOR 10c.

**AMALGAMATED PHONOGRAPH ACCESSORIES CORPORATION**  
Dept. 2—12 East 42nd Street "If it pertains to a phonograph we have it" NEW YORK





### *Jobbers*

**W**ITH full appreciation of the value of the jobber's service, in that he creates a time and place utility, we have held steadfast to the plan of selling our product directly to the phonograph manufacturer. ¶ We have determined upon this policy because of our desire and ambition to keep always in touch with the manufacturers using the Stephenson Motor, that we may know intimately their problems and their ambitions and that we may receive directly from them their criticisms and suggestions. ¶ We thank the many jobbers who have asked to handle the Stephenson Motor and make this statement that our policy may be generally better known.

*STEPHENSON*  
INCORPORATED  
One West Thirty-fourth Street  
*New York City*



**REPAIRING  
AND  
REPAIR PARTS**  
*for all makes of  
Talking Machines*

**BOND'S GRAPHOPHONE SHOP**  
38 Arcade :: Nashville, Tenn.

**CONTINUING SUCCESSFUL TOUR**

**Popular Recording Artists to Cover Large Eastern Territory During Coming Weeks—Make Strong Appeal to Music Lovers**

The Peerless Record Makers, consisting of Henry Burr, Billy Murray, Albert Campbell, Fred Van Eps, John Meyers, Frank Croxton, Monroe Silver and Frank Banta, are continuing their tour of the United States. During the past month their tour has taken them into Canada, where they have met with the highest sort of praise for their work. The Ontario Times, the morning after their concert, said: "Best offering by way of entertainment ever offered in a decade. The only regret is that these artists did not make Hamilton a three-night stand." In Toronto the story of the press tells with what spirit the people attended the concert. It reads: "They played to the largest audience of the season at Massey Hall, which seats 3,400 people, and played to an overflowing audience in a special matinee to 1,400 people who were unable to procure seats for the previous evening performance." A like reception was given these record artists on their stops at Montreal and London.



P. W. Simon

No small part of the success of these artists is due to their able manager, P. W. Simon. Mr. Simon, who handles the booking, transportation and publicity, not only keeps his artists in the best of spirits, but also co-operates to the fullest extent with those who contract for the concert. He plans out press reading matter weeks in advance for the papers to use in the city where the concert is to appear. He sees to it that his artists never miss an engagement unless for some reason absolutely beyond their control. To show to what limits he will go in order to meet his obligations, it is stated that last month during the blizzard his troupe was snowbound in Canada. He finally succeeded, after much delay, in getting as far as Albany. The famous record artists were to appear that evening in Binghamton, and in order to hold to his agreement P. W. Simon chartered the special train to get to his destination on time.

The following current itinerary of the Peerless Record Makers shows the great demand and popular appeal of these artists: April 6, Philadelphia; April 7, Wilmington, Del.; April 8, Baltimore, Md.; April 9, Richmond, Va.; April 10, Norfolk, Va.; April 11, Washington, D. C.; April 12, Johnstown, Pa.; April 13, Cumberland, Md.; April 14, Altoona, Pa.; April 15, Latrobe, Pa.; April 16, Irwin, Pa.; April 17, McKeesport, Pa.; April 18, Punxsutawney, Pa.; April 21, Youngstown, Ohio.; April 22, Tiffin, Ohio; April

**A Period "Tone Arm"**

From those manufacturers who several months hence will be in a position to use a high-grade tone arm and sound box of original design and of superior features, WE INVITE CORRESPONDENCE. Visitors to New York are also cordially invited to our New York offices. Samples of this new arm will be forwarded to the trade shortly after May 15th, and deliveries in quantities will follow in thirty days from that period.

**PERIOD TONE ARM CORP.**  
55-61 W. 17th Street, New York Chelsea 4744

23, Lima, Ohio; April 24, Mansfield, Ohio; April 26, Toledo, Ohio; April 27, Sandusky, Ohio.

**NEW QUARTERS IN MILWAUKEE**

**Wm. F. Kaltenbach Leases Five-story Building to House His Jobbing Business**

MILWAUKEE, Wis., April 7.—Wm. F. Kaltenbach, of this city, has leased a five-story building, 40x100 feet, to accommodate his extensive jobbing business. Mr. Kaltenbach distributes the products of the Independent Talking Machine Co. and the Amalgamated Phonograph Accessories Corp., New York. He is also a distributor of Okeh records, Kaltenbach patent accessories, "Outingphones," Riviera knockdown cabinets, talking machine hardware, etc. Mr. Kaltenbach is also completing a new retail establishment, which he states will be one of the leading retail stores in this city.

San Diego, Cal., claims to have 350 sunny days a year. All aboard!

**TO OCCUPY NEW QUARTERS MAY 1**

M. M. Roemer Sales Corp. Will Be Located at 1123 Broadway, New York, After May 1

On May 1 the M. M. Roemer Sales Corp., wholesale distributors of Vitanola talking machines and Okeh records, will be located in its new quarters in the Townsend Building, 1123 Broadway, New York City. The M. M. Roemer Sales Corp. has built up a large trade in both machines and records and its former quarters were inadequate to handle the large volume of business received. The new offices and warehouses at the above address will provide excellent facilities for handling its business as well as for the proper display of its line. The central location of the new offices will also efficiently aid in the distribution of stock and be of great convenience to the dealer.

The store of the Leo Kahn Furniture Co., Memphis, Tenn., handling the Mandel line, was recently damaged by fire.

**A  
RECORD CABINET  
MATCHING  
VICTROLA NINE A**



309 1/2

309 1/2.—Mahogany, golden oak, fumed oak, weathered oak, nickel plated trimmings, lock and key, shelves interior, casters. Height, 33 inches. Top, 18 1/4 x 21 3/8 inches. Matches New Victrola IX A. Patented rimmed moulding with removable back piece, so machine can easily slide in, giving a perfect "Cabinet-match" appearance. Average weight, crated, 70 pounds.

MANUFACTURED BY

**SCHLOSS BROS.**

637-645 West 55th Street New York

*Cabinets of all descriptions and finishes*

Catalogue No. 20 Ready for Distribution

Have You One?



APPOINTED ADVERTISING MANAGER

J. I. Bernat Becomes Head of Advertising Department of Emerson Phonograph Co.

The Emerson Phonograph Co., New York, announced recently the appointment of J. I. Bernat as advertising manager of the company. Mr. Bernat, who is well known in the talking machine trade, will assume his new duties the end of the week.

During the past year Mr. Bernat has been manager of the dealer service department of the Pathé Frères Phonograph Co., being appointed to that position after extensive work



J. I. Bernat

with the Government. Prior to entering the Government service he was advertising manager of the Pathé Frères Phonograph Co. and in that position co-operated to excellent advantage with the jobbers and dealers throughout the country.

**DIRECT FACTORY PRICE—JUST MENTION THE QUANTITY**

<b>MOTORS</b>	<b>CASTINGS</b>	{ TURNTABLES MOTOR FRAMES TONE ARMS HORNS and THROATS	<b>Stylus Bars</b>
<b>TONE ARMS</b>	Grey Iron		<b>Screw Machine Parts</b>
<b>REPRODUCERS</b>	and Brass for		<b>Talking Machine Hardware</b>

*Direct Quantity Importations On* { **JEWEL and STEEL (Bulk or Packed)**  
**PHONOGRAPH NEEDLES**  
**GENUINE RUBY BENGAL MICA**

*EASTERN REPRESENTATIVE*  
**CHERINGTON MFG. CO.** **D. R. DOCTOROW**  
*IRONCLAD MOTORS* *Vanderbilt Ave. Bldg.*  
*51 East 42nd St., New York*  
*Tel. Vanderbilt 5462*

Mr. Bernat resigned as advertising manager of the Pathé Frères Phonograph Co. to accept a position with the War Savings Organization. He was tour manager for the Second Federal Reserve District in connection with the Victory Loan and was assistant advertising director of the War Savings Organization in the Second Federal Reserve District. As tour manager Mr. Bernat was in charge of all the operatic and concert activities incidental to the Victory Loan and under his able direction these activities contributed materially to the general success of the Loan in the Second District.

During the past few years Mr. Bernat has made a special study of dealer service as applied to the talking machine industry, and with his intimate knowledge of all phases of the advertising field he is equipped to render Emerson dealers exceptional co-operation and service. The mammoth advertising campaign inaugurated by the Emerson Phonograph Co. the first of this year will be under Mr. Bernat's immediate direction and his familiarity with the record industry will doubtless enable him to attain signal success in his new post. His many friends wish him all success.

GEO. W. HOPKINS DINES AIDS

General Sales Manager of Columbia Co. Entertains Staff at Get-Together Session

George W. Hopkins, general sales manager of the Columbia Graphophone Co., was the host at an informal dinner held a few days ago at the Advertising Club, New York. Mr. Hopkins gave this dinner to the heads of his various departments in order to have an informal "get-together" chat incidental to the activities of his department during the past few weeks. Mr. Hopkins recently returned from a fortnight's vacation at Palm Beach and the various happenings in his department during this period were discussed at length.

Among those who attended the dinner were Frank K. Pennington, O. F. Benz, C. K. Woodbridge, W. A. Willson, Lester L. Leverich, H. L. Tuers and Robert E. Rae.

RECORD OF "NIGHT BOAT" MUSIC

The Victor Talking Machine Co. has just announced a new record bearing selections from "The Night Boat," the popular musical comedy now running in New York. Inasmuch as it is believed that the greatest interest in this music will be found in the district in which the show is at present being presented, arrangements have been made to reverse the usual shipping order, beginning in New York and working toward the Western cities.

GARFORD "BABY" PHONOGRAPHS

A Line of Guaranteed Instruments

THE "BABY" MODEL  
RETAILS AT \$6



Description of "Baby" Model  
Plays Little Wonder or 7-inch records.  
Metal Cabinet finished in high grade Ebony  
Enamel with nickel trimmings.  
Length 8 3/4 inches Height 7 1/2 inches  
Width 5 1/2 inches Weight 3 1/2 lbs.  
Provided with one spring worm gear motor.  
5 1/4-inch turntable. High grade sound box,  
with wonderfully clear reproduction. Speed  
regulator.

MODEL X  
RETAILS AT \$10



CLOSED

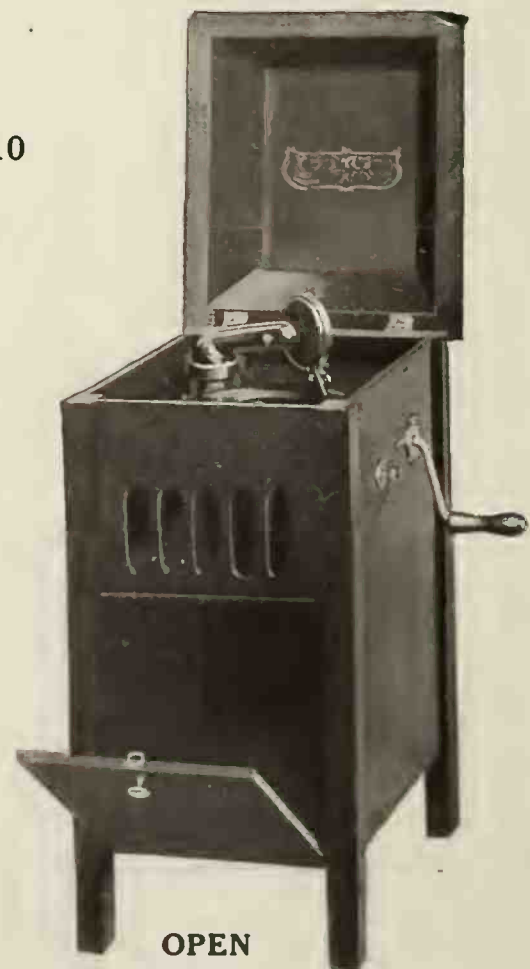

OPEN

Description of Model "X"  
Plays Little Wonder records and also 7-inch records. Cabinet finished in Mahogany  
Height 17 1/4 inches Width 8 5/8 inches  
Depth 9 3/4 inches  
Provided with one spring worm gear motor. 5 1/4-inch turntable. High grade sound box, with wonderfully clear reproduction. Speed regulator.

A LIBERAL PROPOSITION FOR PROGRESSIVE DEALERS

GENERAL PHONOGRAPH MFG. CO. Elyria, Ohio

FORMERLY NAMED THE GARFORD MFG. CO.



**PLAN PUBLIC SCHOOL CONCERTS**

Landay Bros. Arrange for Appearance of Grace Leigh Scott in Important Music Educational Work in the New York City Public Schools

Landay Bros., the prominent Victor wholesalers and dealers, New York, have arranged to present Grace Leigh Scott and an assisting artist in a series of public school concerts for Americanization and the Music Memory Contest. The program arranged for Miss Scott, who, by the way, is a distinctly popular American soprano, is divided into sections, the first, for the lower grades and designed to demonstrate the manner of getting the song message to children so they will remember, and the second, for the higher grades, designed particularly to aid in the Music Memory Contest. A special folder has been issued in connection with the concerts, on the back of which appears an official list of selections used in the Music Memory Contest in the New York City public schools, all of them obtainable on Victor records.



DETERLING  
Style 125

**DETERLING  
TALKING MACHINES**

Are selling big BECAUSE

**THEIR DESIGNS** attract and hold the eye.

**THEIR CABINETS** are built to stay built—not to sell and fall apart and cause endless trouble.

**THEIR SLIDING DOORS** are unique and attractive, and modify the volume WITHOUT MUFFLING.

**THEIR FILING SYSTEM** is very effective and is a quality point that is easy to demonstrate.

**THEIR MERITS**—and MOTORS—keep them sold.

*Send for Our Story*

**DETERLING  
MFG. CO.**

TIPTON INDIANA

**NEW JOBBERS FOR THE SONATA**

Standard Paper Co., Indianapolis, to Handle That Line in a Wholesale Way

Among the new distributors recently added to the representatives of the Kesner & Jerlaw line of Sonata machines, is the Standard Paper Co., Indianapolis, Ind.

The firm is highly gratified in being able to procure such a representative line of talking machines, and one with which they can guarantee prompt deliveries. A strong campaign has been inaugurated by the company, giving publicity to this product, and a special service department to care for the dealers handling Sonata machines has been created.

Twenty-three traveling representatives will introduce the Sonata product to the trade in the Standard Paper Co.'s territory, and deliveries on a large scale will commence immediately.

On Saturday, March 27, M. L. Kesner and N. Jerlaw, of the firm of Kesner & Jerlaw, made a special trip to Indianapolis and demonstrated sample Sonata machines to a meeting of the sales force of the Standard Paper Co. Both Mr. Jerlaw and Mr. Kesner addressed the meeting, and by their sales talk much enthusiasm for the Sonata line was created.

**NEW SPHINX MOTOR CATALOG**

Volume Just Issued Tells of the Quality and Various Features of That Product

The Sphinx Gramophone Motors, Inc., New York, manufacturers of the Sphinx gramophone motor, have just forwarded to the trade the initial catalog describing and illustrating their product. The introductory matter lays special emphasis on the silence and uniformity of speed of the motor and the permanent service which it renders. Much stress is given to the fact that the motor is the result of research and experiments of skilled and experienced motor engineers, who have endeavored to produce a motor without any defects in design and construction, the motor being turned out for use only after exacting tests which, it is stated, are equivalent to ten years' normal use. The design and construction are minutely described, closely followed by illustrations of the various essential parts.

The factory of the company is most modern and is thoroughly equipped in every detail. It has been producing high-grade engineering specialties on a large scale for over fifty-six years. The officers of the company feel certain that the Sphinx motor will be obtainable at all times in any quantities, and that the high standard of its construction will be permanently maintained. The company feels that in addition to its other qualifications, the appearance of the Sphinx motor is a strong selling point. The back page of the catalog is given over to a reproduction of a photograph of the factory at Flushing, L. I., which shows the shipping facilities of the company, both by rail and water.

**COLUMBIA MANAGERS IN NEW YORK**

N. J. Wilcox, H. E. Gardner and W. S. Parks All Bring Excellent Reports From Territories

Among the recent visitors to the Columbia Graphophone Co.'s executive offices in the Woolworth Building, New York, were N. J. Wilcox, H. E. Gardner and W. S. Parks, managers of the Philadelphia, New Haven and Baltimore branches, respectively. All of these visitors spoke enthusiastically of the business outlook in their territories, and Mr. Gardner was congratulated upon the fact that the New Haven branch has stood at the top of the list for the past three months in the reports compiled by General Sales Manager Hopkins. These lists are based on a given quota as compared with 1919 business, and the New Haven branch has stood first for the past three months.

**WARNING!**

WALL-KANE steel needles made in America of American steel, and by American workmen are, to-day the standard trade mark needles of the phonograph industry. Like any article that is a proven success, WALL-KANE steel needles are being imitated.

The highest grade steel needle of domestic manufacture, is subjected to chemical processes by which the point of the needle is greatly improved. Three different coatings of certain chemical solutions are placed on the point of the needle, softening the point so much so that the needle will positively play ten records before the friction with the grooves will wear off the three coatings and reach the original grain of the point.

The solutions placed on the point are of such character that their distribution is beneficial to the grooves of the record, thereby greatly prolonging the life of the record. The softness of the point of the WALL-KANE NEEDLES minimizes the scraping sound of the ordinary steel needle, thereby greatly improving the clearness and tone of reproduction.

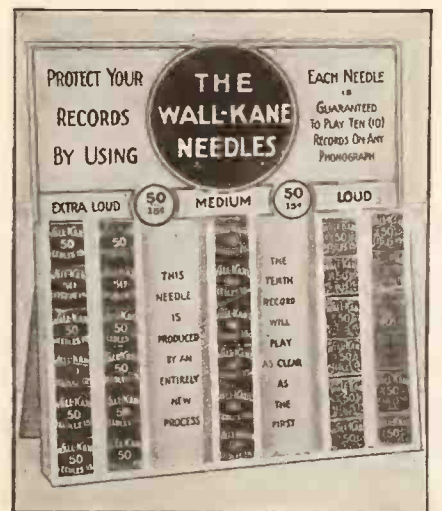

**BEWARE OF IMITATIONS**

This handsome metal enamel display stand holds 60 packages, 2 doz. extra loud, 1 doz. medium and 2 doz. loud; each package containing 50 WALL-KANE NEEDLES, retailing for 15c. Price of Stand to dealers, \$4.60. Single packages, 7½c.

*Jobbing Territory Open*

**Progressive  
Phonographic Supply Co., Inc.**

145 WEST 45th STREET  
NEW YORK



# The Melodia



STYLE F

Size 20½ x 22 inches; height 48½ inches; automatic stop; tone modifier; floating horn; powerful silent double spring motor.

Record shelves are spacious—accommodating 150 records.

**Retail Price**  
**\$160.00**

**Surprisingly Liberal Discounts**

We have been developing our line of machines for the past six years. Our output has not been large and has been absorbed by Dealers near home. This year we have made arrangements to double our capacity, and desire more Dealers.

The "MELODIA" line is one of quality throughout.

Agencies for the complete line are going fast.

Write

**THE MELODIA CO.**  
Troy - - Ohio

# YAZOO RIVER RED GUM

Specials for prompt shipment:

- 3 cars 1¼" No. 1 Common Plain Red Gum.
- 10 cars 2½" No. 1 Common and Better Plain and Qrtd. Red Gum.
- 8 cars 3" No. 1 Common and Better Plain and Qrtd. Red Gum.
- 5 cars 1" 1st and 2nds Qrtd. White Oak.
- 5 cars 1" No. 1 Common Qrtd. White Oak.
- 7 cars 1" 1st and 2nds Qrtd. Red Oak.
- 5 cars 1" No. 1 Common Qrtd. Red Oak.
- 3 cars 1½" No. 1 Common Sap Gum.
- 2 cars 1¼" 1st and 2nds Qrtd. Red Gum.
- 5 cars 1¼" No. 1 Common Qrtd. Red Gum.

Our Red Gum is of soft texture and rich, dark color. Specially manufactured and seasoned.

Send us your inquiries for all kinds of cabinet woods.

## THOMAS & PROETZ LUMBER CO.

3400 Hall St., St. Louis, Mo.

### VOCAL THERAPY FUND STARTED

Value of Music as Curative for Many Diseases  
Recognized by British Society

"The therapeutic value of singing, both by causing full expansion of the lungs and by its invigorating effect on mind and body, is not fully appreciated," writes the London correspondent of the Journal of the American Medical Association. "A vocal therapy fund has been formed with a committee containing several well-known leaders of the profession. In appealing for funds the committee points out that the work is partly curative, consisting of individual training, under medical supervision, of men suffering, through shock and strain, from stammering, aphonia or mutism, and partly restorative by instruction in choral singing, taking advantage of the well-known power of song to cure ailments affecting speech and respiration."

"Trained choirs have been organized which give concerts both in and out of hospitals, and 'song centers' have been started at general and special hospitals and hotel centers in London and the provinces. It is thought that the treatment would be especially applicable to the many thousands of medically unfit men discharged from the military hospitals who are unable to return to the full use and enjoyment of life."

### LONGEST MUSIC SEASON HERE

New York's longest as well as most prosperous music season, passing all records of former years, will continue not only through April but well on into May. Twenty-four events are now on the schedule of Carnegie Hall, and not fewer than thirty-six at Aeolian Hall. According to Rudolph Heck and Lawrence FitzGerald, of the respective box offices, the like of this never happened before and indicates unusual interest on the part of New Yorkers.

## H. J. SMITH LABORATORIES

*Jewel Manufacturer*

EXECUTIVE OFFICES,  
FINISHING and  
RECORDING  
LABORATORY JEWELS

Plant No. 1  
**833 Broad Street**  
Telephone 2896 Market  
**NEWARK, N. J.**

SAWING  
GRINDING  
ROUGHING  
ROLLING and  
EXPERIMENTAL  
LABORATORY

Plant No. 2  
**54½ Franklin St.**  
**NEWARK, N. J.**

Manufacturer of

Phonograph Diamond and Sapphire Reproducing Points—Recording Laboratory Jewels—Rough Diamond—Diamond Powder—Experimental Work. Jewels manufactured for all talking machine records. Consulting Specialist on all experiments relating to any new recording grooves. Recording problems satisfactorily worked out.



## THE VISION

Devoted to the Interest of the Educational Work Being Conducted by the Talking Machine Dealers and Jobbers

Greatest impetus was given the movement toward a more complete and comprehensive study of Music Appreciation in the schools when the National Music Supervisors' Convention met in Philadelphia for its thirteenth annual meeting, March 22 to March 26. Wednesday, March 24, was devoted to a section on Music Appreciation in the Grades by means of talking machine records. The chairman of the section was Miss Sudie L. Williams, supervisor of music, Dallas, Tex., and the secretary, Miss Alice Inskeep, of Cedar Rapids, Ia. The subjects and speakers were as follows: "How to Introduce Music Appreciation in Schools Which Have No Music," Mary J. Armitage, Bowling Green, Ky.; "Relation of Music Appreciation to Other Phases of Music Work," Ernest Hesser, State Normal College, O.; "Supervisor's Part in Making Grade Teachers Efficient in Music Appreciation," Mabelle Glenn, Bloomington, Ill.; "Relation of Music Appreciation to the Schoolroom," Agnes M. Fryberger (author of "Listening Lessons"), Minneapolis, Minn.

On Wednesday afternoon Music Appreciation in the High School was given the major portion of the program. Miss Marie F. McConnell, of Philadelphia, Pa., acted as chairman and Florence E. Baird, East Radford, Va., as secretary. The subjects used in correlation to the talking machine were: "Music as Seen Through Literature and Art," W. P. Kent, Ethical Culture School, New York City, and "The Use of the Talking Machine in Our Work," Glenn Tindall, St. Louis, Mo.

The Victor Talking Machine Co. acted as host at the convention banquet, which was given on Friday evening, March 26. Mrs. Frances E. Clark, director of the educational department and founder and past president of the National Music Supervisors' Conference, made the initial address of the evening. "Past Prophecy." Dr. Hollis Dann, of the Cornell School of Music, acted as toastmaster, while Dr. John H. Finley, president of the University of the State of New York, addressed the Convention on "The Art of Using One's Leisure Time." Princess Watahwaso, the Penobscot Indian mezzo-soprano and a Victor artist of great pop-

ularity, sang the songs of her own people and some of the harmonized Lieurance and Cadman songs for the assembled guests. Reinald Werenrath, Victor artist, brought to the Convention a new conception of American songs in his lovely rendition of "Duna," a Kentucky Lonesome Tune, a May record on the Victor supplement.

\* \* \* \* \*

A new publication of much interest just issued by the Victor Co. is entitled "Music Appreciation for Kindergarten and Primary Grades," and has been published in response to an ever-increasing demand for a textbook and guide for the presentation of this fascinating and important subject for little children. The new volume has a foreword by Miss Patty Hill, director of kindergarten and primary grades, Teachers' College, Columbia University, New York, and contains a great variety of material governing instrumental music, descriptive music, poetic thought, model lessons, fairy stories, myths of music, nature study, etc. It is a book that should enjoy particular popularity in educational circles throughout the country.

\* \* \* \* \*

It is hoped that the practice that has developed of including in concert advertisements in the daily papers information that the artist records exclusively for certain talking machine records will continue to grow, for it is the most effective sort of publicity. For many years it has been customary for such concert and recital advertisements to carry a line stating that this or that piano was used by the artist, and it is logical to assume that if such advertisements brought results for the piano houses where an investment of several hundred dollars is required, much more definite results should be realized from record announcements where the investment involved is only a matter of a dollar or so.

### RETURNS FROM TEN-WEEK TRIP

Chas. H. Huesgen Visits Every Pathé Jobber in Behalf of Hustylus—Attachment Is Meeting With Gratifying Success

Chas. H. Huesgen, secretary and treasurer of the Herbert & Huesgen Co., sole distributors for the Hustylus attachment, returned recently from a ten weeks' trip to the Pacific Coast. On this trip, Mr. Huesgen visited every Pathé jobber in the country, and conferred with them regarding the merchandising and sales plans for the Hustylus, which plays Pathé records on

## BROWN, McMANUS & CO.

51 East 42d Street  
New York

41 West Street  
Boston, Mass.

The *RIPPEN*  
"Interpretone"

It's the best Talking Machine after all.

### Portrola

A Phonograph that IS conveniently portable—"Built like a Traveling Case"

(Descriptive advertisement on page 186)

### Operathone Records

New Lateral Records of merit

### Trimpoint Needles

Phonograph Needles of superior quality



MODEL 160  
Hgt., 45 ins.; Width, 20 ins.; Depth, 23 ins.  
Mahogany, Walnut and Oak.

## Major-Tone

Represents not old ideas made over but the best ideas made practical.

This machine is designed for YOU—**THE DEALER.**

It is a machine you can honestly sell and feel sure of no come-backs.

Our discounts are all that is consistent with good business and a worthy product.

We Supply  
Pathé Machines and  
Records

**MASTERTONE PHONOGRAPH CO.**  
East Liverpool Ohio

all talking machines not equipped with a universal tone arm.

In a chat with The World Mr. Huesgen stated that the reception accorded the Hustylus has been gratifying beyond all expectations. The Pathé jobbers are enthusiastic regarding the merits of the attachment, and Mr. Huesgen received orders for over 300,000 Hustylus attachments on this trip.

Pathé distributors commented particularly upon the extreme simplicity of the attachment and its effectiveness. Pathé dealers throughout the country are using it as a stimulant for the sale of Pathé records and are featuring it in their advertising campaigns. In their newspaper advertising many of the dealers offer to give a Hustylus free of charge to all purchasers of five or ten Pathé records.

Mr. Huesgen is now making arrangements to establish representatives for the Hustylus in all parts of the world, and the distribution of this attachment in the United States is in the hands of Pathé jobbers exclusively.

Time now to plan for Summer trade.



### PLANS FOR JOBBERS' CONVENTION

Details Now Being Arranged for Annual Meeting of National Association of Talking Machine Jobbers at Atlantic City in June

Plans are proceeding apace for the annual convention of the National Association of Talking Machine Jobbers, which is scheduled to be held at the Hotel Traymore, Atlantic City, on Monday, Tuesday and Wednesday, June 28, 29 and 30. The details are being worked out by L. C. Wiswell, chairman of the arrangements committee, and it is stated that a thoroughly constructive program is being laid out for the sessions.

As was the case at the recent meetings of the executive committee of the association, particular attention will be given to ways and means for enabling the wholesalers to place their businesses on a more efficient basis, in preparation for the situation that is expected to develop as the output of the Victor factory more nearly approximates the demand. There will be scheduled a number of addresses and papers by those prominent in the industry, all directed towards that end.

The selection of Atlantic City as the convention center is in accordance with the usual policy of the Jobbers' Association, for that city is not only recognized as an ideal meeting place by the jobbers, but is close enough to the Victor factory to make it possible for the delegates to attend the convention and also take up at the same time matters with the factory.

The program will not be one of all work and no play, and, although there is no question but that the death of John Barleycorn has had its effect upon the gay life at the popular seaside resort, there will be provided plans for entertainment that should prove most satisfactory, not only to the jobbers themselves, but to the many ladies who will accompany them.

The jobbers' convention will follow the mid-year meeting of the Board of Control of the National Association of Music Merchants,

# ALBUMS



BUY DIRECT  
FROM MANUFACTURER

THE BOSTON BOOK CO. INC.

57-65 Hope Street, Brooklyn, N. Y.  
501-509 Plymouth Court, Chicago, Ill.

which will be held at Atlantic City on June 25 and 26. These dates are considered most convenient in that several members of the Board of Control are also prominent in the affairs of the Jobbers' Association.

#### INCREASES LYRE-OLA PRODUCTION

St. Louis, Mo., April 9.—The Lyre-Ola Mfg. Co., of this city, which was incorporated more than a year ago with a capital stock of \$150,000,

is now commencing to produce instruments in a large way at its factory, 1504 Pine street, where 30,000 square feet of floor space is occupied. The Lyre-Ola, which has several exclusive patented features, is made only in console types in the Adam, Queen Anne and William and Mary periods. It has won an excellent reputation in St. Louis and environs. F. La Pierre, president of the company, devotes his entire time to the management of the business and has an able staff of co-workers.

# ACME

*Stands for Highest Quality and Prompt Service*

WE MANUFACTURE

## ACME MICA DIAPHRAGMS

WE SUPPLY AFRICAN AND INDIA RUBY EXCLUSIVELY

*Any Size and Any Thickness and Quantity*

LET US HAVE YOUR INQUIRY

## ACME MICA COMPANY, Incorporated

*Importers and Manufacturers*

56 BLEECKER ST.,

Phone, Spring 7197 and 7198

NEW YORK



THE TALKING MACHINE WORLD SERVICE



Robert Gordon's Page -



A DEPARTMENT DEVOTED TO PROMOTING RETAIL SALES

# Put Your Windows to Work!

Here are half a dozen ways to make the public stop, look and buy

## YOUR MAY DAY WINDOW

A CHARMING May Pole display can be arranged for May 1 at very little expense. In the center of your window place the May Pole, which you can make out of a broomstick or mop handle, set into a flat base, so it will stand upright. This should be completely covered with white crepe paper. Flat on the floor of your window place eight or ten new records, forming a circle around the pole as a center. Each record should be three or four feet distant from the pole.

On the center of each record stand a Kewpie Doll. You can borrow or rent the Kewpies for a dollar or two from a toy dealer. These dolls have both hands outstretched. On one hand hang a small card bearing the title of the record on which the Kewpie is standing. From the other hand a strip of crepe paper leads to the top of the May Pole. The crepe paper comes in rolls of two-inch width, suitable for this purpose. Fasten it at the top of your pole, and give it a turn or two around the pole before extending it to the Kewpie's hand. Choose delicate colors for your crepe paper, such as pink, yellow, lavender, pale blue and light green. In the background place several talking machines. Do not have any other signs or cards in your window, as these will distract attention from your May Pole and weaken its effect.

## FOR "L" SHAPED WINDOWS

ONE of the subscribers to the Talking Machine World Service sent me this request: "We have an 'L' shaped window of limited size, being seven feet long and three feet wide in each wing. What display arrangement will look best and how can an effective background be made?"

Probably many of you also have "L" shaped windows to deal with, and therefore these suggestions may be of assistance:

The chief thing to remember is to make the window balance. The center of gravity should be in the angle of the "L". Try always



Linking up your window with a current musical show at one of your local theatres is bound to sell records of song bits from the show. The large photographs are loaned for the occasion. This is a well-planned window by the Cable Piano Co., of Toledo, O.

to put the largest object at that point, with one smaller one in the short wing and two smaller ones in the long wing. Keep your background simple and severe—then the objects in the window stand out more emphatically. If your background is dark, the objects merge into it and are lost. If the background is light, the objects stand out sharply. A tint about the shade of coffee with cream in it is always good and harmonizes with any colors you may use in signs or cut-outs. If you are going to do any painting of woodwork in your window, use Devoe's Jap Coach Paint. Flake white, tinted with a little crimson, orange, cobalt blue and lampblack makes a warm, pleasing tone. This is a quick-drying paint. Rub down after each coat with No. 00 American Steel Wool, and after the seventh coat, polish with Johnson's Prepared Wax. Drapes, if used, should be severe in lines and of same tone as your "café-au-lait" woodwork. Don't let the draper put in any scallops, curves, or fussy shapes. Straight lines are the thing.

Light your windows from the bottom, not from the top. This method is far more effective, just as are footlights on the stage.

## CLOSE-UP VIEWS

A WINDOW display plan that is making a big hit in other lines of business, and is equally well adapted to talking machines, is the "close-up" type of display. When merchandise is set in the rear of a window, passersby do not see it unless they stop and look. But when the objects on display are placed so



Simplicity is the chief merit of this window arranged by the Carl Newton Co., of San Antonio, Texas. It features the famous artists most effectively. Note the little Kewpie Dolls, with outstretched hands. The row of little dogs is a pleasing touch, and the big dog supplies a central point of interest.

close to the glass that you can almost handle them apparently, everybody passing your window is sure to see them. To arrange a "close-up" display make a false back for your window. This may be made of Beaver board covered with wall paper. A plain light tone or simple stripe design is best for this purpose. Count the number of talking machines that your window will accommodate when placed side by side. If your window will hold five, for example, place three of them on the floor, close against the glass. Between these three set the other two on platforms 12 to 15 inches high. These platforms are also covered with the wall paper. Above the machines display new records, fastening them flat against your false backing of Beaver board. Colored cut-outs which the manufacturers supply may also be used, or lettered signs giving the titles of the records on display. Place some strong electric lights at the bottom of your window, shaded from the street and casting their light against the false backing, after the manner of footlights on the stage. This display is such a radical change from your regular window trims that it will attract a lot of attention.

## FEATURING AL JOLSON

IF YOU sell popular sheet music, or if you sell records of Al Jolson's songs, here's a window display plan that will help you to boost your sales. All of Jolson's song hits have his photograph on the title page. Get copies of six or seven of the song hits which Jolson has made famous in the past. Set these across the center of your window, in a row. In the center of the row, and raised up a foot above the others, put Al Jolson's newest hit, "Swanee" or "Chloe." Back of this a card about 2 x 3 feet reads:

"His old hits were good,  
but his newest is the blue ribbon winner!"  
SWANEE  
is the greatest of  
AL JOLSON'S  
song successes  
COME IN NOW AND HEAR IT

On the card place a blue ribbon rosette, made up to imitate the ribbons awarded to winning horses at a horse show.

EDITOR'S NOTE—Mr. Gordon, who writes this monthly page, is also director of "The Talking Machine World Service." Mr. Gordon will publish on this page any good ideas submitted by you for the benefit of the trade, and also answer any questions you ask him concerning merchandising problems. Use this department as much as you like. It is intended to serve you.





Minneapolis, Minnesota

Fargo, North Dakota

*THE Stone Piano Company's Two Stores—the Aeolian-Vocalion on Exhibition and Sale in these Stores and the Great, World-wide Aeolian Organization Responsible for the Production of this Finest of All Phonographs*



# THE STONE PIANO COMPANY

*Wholesale Distributors for Minneapolis, North and South Dakota, Montana and Western Wisconsin*

*for the*

## AEOLIAN-VOCALION

*And the New Lateral Cut*

## VOCALION RECORD

The Aeolian-Vocalion is the finest of all phonographs. Musically and mechanically it has no serious rival in the entire industry. It is the product of the world's foremost musical instrument manufacturers. Re-inforced by the wonderful new Vocalion "lateral cut" record, its representation is the most valuable and profitable proposition in the phonograph field. Merchants in the territory specified above are invited to write either of our stores for information and a copy of our dealer service portfolio.

### THE STONE PIANO COMPANY

MINNEAPOLIS, MINNESOTA

FARGO, NORTH DAKOTA



**DEATH OF HOMER N. BARTLETT**

**Widely Known Composer of High-class Songs Passes Away in His Seventy-fifth Year**

Lovers of the best in talking machine records will regret to learn of the death of Homer N. Bartlett, the well-known composer and organist, who passed away at his home in Hoboken, N. J. on April 5, in his seventy-fifth year. Mr. Bartlett was the composer of more than eighty songs, many of which have won tremendous popularity, notably "A Dream," which, as recorded by the late Evan Williams for the Victor Co., has had, and still has, a wide vogue. It is a wonderful example of the best in recording and an admirable presentation of a very lovely song.

Mr. Bartlett was organist of the Madison Avenue Baptist Church, New York, for thirty-one years, and had written a number of oratorios and some operas, as well as a number of religious and dance numbers for the piano. He was a splendid type of American, whose passing will be greatly regretted.

**PARAMOUNT DISPLAY BY JOBBERS**

From April 19 to 28 inclusive, Paramount talking machines and Paramount records will be displayed by the Shipley-Massingham Co., Pittsburgh, Pa., distributors for Western Pennsylvania and West Virginia, in the Fort Pitt Hotel, Pittsburgh, Pa. H. W. Cross, who is in charge of the wholesale department of this distributor, and Fred Clark, the Paramount factory representative, will welcome all visitors who desire to inspect Paramount products.

Dealers in this territory will undoubtedly accept the invitation of the Shipley-Massingham Co. to visit the company's exhibit at the Fort Pitt Hotel, for this progressive jobber is planning to introduce many distinctive sales features in behalf of Paramount products.

**NEW SCHLOSS PLANT PROBABLE**

It is understood that Schloss Bros., 645 West Forty-fifth street, New York, the well-known cabinet manufacturers, who make a specialty of a product known to the trade as "Cabinetmatch," are building a factory in the upper part of New York City. When the item was called to the attention of Edwin Schloss of the above firm, he neither would confirm nor deny the veracity of the report.

**SOSS**  
**INVISIBLE HINGES**

Fine cabinet work has always demanded that hinges be as inconspicuous as possible.

**Soss Hinges are Invisible**

They are therefore ideal for beautiful cabinet work as the preservation of the beauty of unbroken lines in better grade cabinets is thus insured.

The leading manufacturers of the industry use Soss Hinges.

Soss Hinges are so accurately made and so easy to install that they save time and labor, as all mortising can be done by machine.

**SOSS MANUFACTURING CO.**  
GRAND AVE. AND BERGEN ST.  
BROOKLYN, N.Y.

**H. L. WILLSON BOUND FOR COAST**

**General Manager of Columbia Graphophone Co. to Visit Many Prominent Cities**

H. L. Willson, vice-president and general manager of the Columbia Graphophone Co., left Saturday for an extensive trip to the Pacific Coast. According to his present plans, Mr. Willson will visit Chicago, Minneapolis, Denver, Portland, San Francisco and Los Angeles. The Columbia branch managers in these cities are ready to give Mr. Willson gratifying reports as to Columbia activities in their territories.

F. S. Whitten, president of the Columbia Co., returned a few days ago from the South, and has resumed his activities at the helm of the Columbia organization.

**ANNOUNCES NEW SALES PLAN**

SAN FRANCISCO, CAL., April 5.—The phonograph division of the Magnavox Co. of this city, which is the distributor of the products of the Sonora Phonograph Co., New York, has announced a new policy of distribution in the States of Oregon, Washington and Idaho.

In the past it has been the policy of the company to distribute the Sonora products through sub-distributors, but this policy of marketing has been radically changed, and at a very early date the company will open up its own distributing headquarters in the Northwest territory. An intensive sales campaign is now under way, and applications for Sonora agencies direct from the dealers are being received from all parts of the Northwest.

**PUSH SMALLER VICTOR MODELS**

Collings & Co., the well-known Victor distributors of Newark, N. J., recently inaugurated a special sales campaign on behalf of the Victor models IV and VI, in connection with which they have issued very effective display material.

L. W. Collings, of the above company, states they found the trade to a great extent overlooking the possible sales from the models in question, and that it had invariably been the rule recently to sell such models only for cash, whereas it is the Collings & Co. belief that thousands of additional sales can be made if the goods were to be sold on easy payments.

**NEW HOME FOR GRAND T. M. CO.**

The Grand Talking Machine Co., 366 Adams street, Brooklyn, N. Y., manufacturer of "Dulciphone" phonographs and needles and distributors of Q R S rolls and Emerson records, will be located in new quarters at 268-270 Flatbush avenue, Extension, on and after April 25. Owing to the greatly increased business during the past year the company found it necessary to seek larger quarters. The new home affords greatly increased floor space and it is being equipped with special facilities for serving the trade. A modern showroom will be one of the attractions of the new quarters.

**PATHE DEALERS and JOBBERS**

**The SCOTTFORD Model I REPRODUCER**

Will be a great aid in developing the sale of Pathe Records. Made to fit the Victor gooseneck exactly—it is as quickly attached as the Victor Reproducer is quickly removable. An Attachment also made for applying it to the Columbia Tonearm. Order a sample and realize the profit for you in the richness of its tone—surpassing all in purity, sweetness and power.

**NET PRICES OF SAMPLES PREPAID**

Nickel Plated Scotford Model I Reproducer - \$5.50  
Gold Plated Scotford Model I Reproducer - 6.50  
Nickel Plated Scotford Attachment for Columbia .35  
Gold Plated Scotford Attachment for Columbia .50

Submitted on Approval, subject to return, in which event the full price paid will be promptly refunded.

Liberal Reduction on Quantity Orders  
Profitable Arrangement for Jobbers

**Barnhart Brothers & Spindler**  
Superior Specialists for Phonographs  
Monroe and Throop Streets, CHICAGO

**Announcement**

**ESCO MUSIC & ACCESSORIES CO.**

137 Lawrence Street Brooklyn, N. Y.

CARRY A GENERAL LINE OF

**Reliable Accessories**

INCLUDING

Portophones Peerless Albums  
Brilliantone Needles Arto Music Rolls

MOTTO:  
**EFFICIENCY SERVICE CO-OPERATION**  
To Dealers

PROCURE QUOTATIONS BEFORE BUYING ELSEWHERE  
OSCAR ZEPERNICK JOSEPH A. KERR



**PLANS TO INCREASE PRODUCTION**

**M. L. Kesner, of Kesner & Jerlaw, Returns from Visit to Company's Plants in the West—Big Output Necessary to Meet Demands**

M. L. Kesner, head of the New York office of Kesner & Jerlaw, manufacturers of the Sonata phonograph, returned to New York early this month after spending several weeks in the West on an inspection tour of the seven factories of the Kesner & Jerlaw organization. The purpose of these visits was to encourage production and to complete plans at the shipping points to care for several new large contracts with distributors of Sonata products.

Kesner & Jerlaw have won a most favorable reputation during the past two years not only



M. L. Kesner

for the quality of their products, but also for their promptness of deliveries and the service they render to the organizations who become their distributors.

In a recent statement to a representative of The World, M. L. Kesner said that in order for his company to fill the contracts for the year 1920 it will be necessary to ship from all their factories not less than four carloads of machines per day. Most of the territory in the United States has already been allotted to Sonata jobbers and they have now representatives in most of the large trade centers. These have been selected with great care, and these firms are amply equipped to carry out the high standard of service set by the manufacturers.

It is the aim of Kesner & Jerlaw to produce only the highest grade merchandise. The fact that the distributors who handle their products during the year 1919 readily renewed their contracts for this season, and in most instances greatly increased the size of their orders, demonstrates the standing of the Sonata line.

Jobbers are being constantly added to the Kesner & Jerlaw organization, and it is now aimed for all the various representatives of Sonata products to carry on a tremendous advertising campaign.

The factories of Kesner & Jerlaw were never in a better position to fill the demands than at present, and they promise there will be no delay in taking care of any dealer taking on their line.

**A VISITOR TO NEW YORK**

A recent visitor to New York was Frederick B. Smith, president of the Wolverine Mfg. Co., 1335 Book Building, Detroit, who is contemplating the purchase of a large plant which will be devoted largely to the manufacture of cabinets for talking machines.

The demand has been very great in Washington for the new Edison record, "Looking This Way," the favorite hymn of the late Admiral Dewey. This hymn was played by the United States Marine Band at Admiral Dewey's funeral.

**OPERA STARS VISIT CLEVELAND**

**Victor Salesmen of That City Gather in Cleveland Talking Machine Co.'s Headquarters to Greet Distinguished Recording Artists**

CLEVELAND, O., April 5.—The Chicago Opera Co. brought three famous Victor stars to this city recently, and by invitation each one paid a special visit to the offices of the Cleveland Talking Machine Co., Victor wholesalers. They were greeted by the assembled Victor dealers of this city who practically stripped their forces of sales people, that all might enjoy the unusual privilege of direct contact with these famous artists.

Mme. Galli-Curci, Edward Johnson and Titta Ruffo were the three Victor stars who were welcomed by the Victor dealers at the establishment of the Cleveland Talking Machine Co. They were all given an enthusiastic reception, and were deeply appreciative of the cordiality extended them by the Victor representatives.

This trio of celebrities represents three dis-

tinct types of artists—Mme. Galli-Curci, the famous coloratura soprano; Edward Johnson, America's great tenor, and Titta Ruffo, the renowned operatic baritone. To each was put the question: "How did you feel after making your first record?" Ruffo said, "I wanted to



Noted Stars at Cleveland T. M. Co.'s Store cry." Galli-Curci said, "A great fear—it is so permanent." Johnson said, "I sang so hard I was weak from exhaustion." In each is an artist's demand for perfection, and as a record is infallible in its reproduction of the voice.

*The*  
**PHONOMOTOR**  
 Trade Mark Registered U. S. Pat. Office

**The first and most perfect electrical equipment for the**  
**Phonograph**

(Patented 1918)

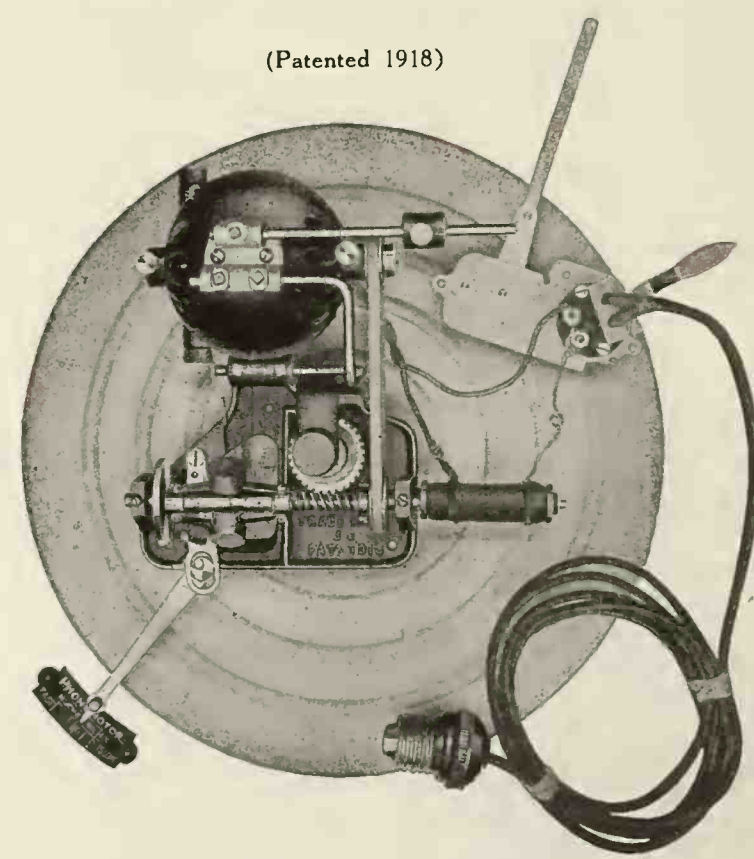

**INTERCHANGEABLE—STANDARD—SIMPLE—UNIVERSAL**  
 110-20 A. C. or D. C.: also adapted for 220 V.  
**Silent Absolutely—Regulation Perfect—Everlasting—Guaranteed**  
 Patented in United States and Canada

Discard your old Spring Motor Have our representative install a  
**Phonomotor in your Phonograph**

**AUTOMATIC STOPS** supplied on all Phonomotors and Spring Motors, an approved, reliable stop,  
**THE PHONOSTOP** Supplied to the Trade.

*Write for Quantity Prices NOW*

**G. CLAY COX** - - **73 State Street, Rochester, N. Y.**



## CLEVELAND TRADE ENLISTS IN THE CAUSE OF MUSIC

Talking Machine Dealers Take Part in Live Meeting to Start Music Advancement Campaign—Some Excellent Publicity by Local Houses—Death of Mrs. Otto May—News of Month

CLEVELAND, O., April 5.—One of the most interesting gatherings of the local music trade interests, including talking machine dealers, was the meeting and dinner held at the Mandarin Café on March 30, where plans were discussed for launching in Cleveland a campaign in behalf of better music.

The dinner was planned by George M. Ott, president of the Cleveland Music Trades Association; A. B. Bender, city commissioner for the National Bureau for the Advancement of Music, and Henry Dreher, head of the B. Dreher's Sons Co.

Rex C. Hyre, secretary of the Piano Merchants' Association of Ohio and assistant secretary of the Cleveland Music Trades Association, fathered the dinner idea.

The guests of honor were C. L. Dennis, secretary of the National Association of Music Merchants, and C. M. Tremaine, director of the National Bureau for the Advancement of Music.

Mr. Tremaine was brought here by M. V. DeForeest, of Sharon, Pa., first vice-president of the National Association of Music Merchants.

Half of the members of the Cleveland Piano Merchants' Association were present, as were several talking machine dealers, including T. A. Davies, manager of the Victrola department of the William Taylor & Sons Co., and president of the Talking Machine Dealers' Association of Northern Ohio.

The speakers included Messrs. Tremaine, Dennis, DeForeest, Ott, Bender, Davies, Dreher and others.

The guests, in addition to those already named, included E. P. White, of the Bailey Co.; Charles K. Bennett, general manager, and E. B. Lyons, sales manager, for the Eclipse Musical Co.; Otto and Fred'k Muehlhauser, of the

Muehlhauser Bros. Piano Co.; J. W. Kegel, of the Harmony Music Shoppe Co.; Walter S. Rieder, of the Hart Piano Co., and Harmony Music Shoppe Co., who is secretary of the Cleveland Music Trades Association; O. M. Mattlin, of the Home Piano Co.; C. H. Randolph, Rex C. Hyre, H. W. Jones; a representative of the A. B. Smith Piano Co., of Akron; local newspaper representatives and others.

Mr. Ott, after expressing his satisfaction over the joint gathering of piano, player-piano and talking machine merchants, urged co-operative efforts in stimulating the cause of music and said whatever is done by dealers must be done in the proper spirit, if results sought are to be achieved.

He then turned the meeting over to Mr. Bender, who called on Mr. Dennis for a talk.

Mr. Dennis discussed the wide field which the National Association of Music Merchants occupies and laid stress on the fact the Music Industries Chamber of Commerce now has within its fold eleven units of the music trade industry.

"The talking machine manufacturers have no organization," he said, "but the individual manufacturing concerns have joined. The Better Business Bureau is watching all this. We are accomplishing things through organization and that is what you are here for to-night, to organize for the business of stimulating a demand for better and more music in Cleveland."

Mr. Dennis pointed out the achievements of the Dallas Music Commission and told what had been done in Milwaukee to further the cause of music and interest in musical instruments and community singing.

Mr. Tremaine gave a short history of the origin and growth of the National Society for the Advancement of Music and said the present

### A Period 'Tone Arm'

From those manufacturers who several months hence will be in a position to use a high-grade tone arm and sound box of original design and of superior features, WE INVITE CORRESPONDENCE. Visitors to New York are also cordially invited to our New York offices. Samples of this new arm will be forwarded to the trade shortly after May 15th, and deliveries in quantities will follow in thirty days from that period.

PERIOD TONE ARM CORP.

55-61 W. 17th Street, New York Chelsea 4744

organization is far-reaching and seeks to spread the gospel of good music through many avenues and interest churches, daily newspapers, philanthropists, community and civic organizations, corporations, schools, music supervisors in educational institutions and otherwise to give publicity to the society's purposes.

The current issue of The Total Eclipse, house organ of the Eclipse Musical Co., prints the following: "Just as we go to press comes the sad news of the death of the wife of Otto May, Victor representative for the State of Ohio. They had just planned a several months' trip over the territory, when Mr. May was taken ill and confined to his bed for several weeks, during which time his wife took care of him. After his recovery, she became ill and pneumonia developed."

L. Meier & Sons, 4400 Clark avenue, have beaten other Cleveland musical instrument retailers to it in equipping a truck for delivering Victrolas. The delivery car is an idea of Louis Meier, is built on a Hudson chassis and creates somewhat of a sensation in the city, the effect not being lessened when a ten-toned Gabriel horn warns pedestrians to clear the right of way. As an advertising proposition the truck is certainly one of the cleverest ever seen in the city.

The Total Eclipse house organ of the Eclipse Musical Co., discussing "exclusive service" rendered by its service director, Mr. Savage, points

(Continued on page 226)

# Weser Phonographs

backed by 41 YEARS' experience in manufacturing pianos, recognized throughout the piano trade for their exceptional value.

We invite comparison of the Weser Phonograph with other makes. Many of our best customers have been acquired in this manner.

Our factory contains over three acres of working floor space. Send us sample order, make comparisons as you choose—we are content to abide by your decision.



WESER  
520-530



BROS., Inc.  
W. 43d St.

NEW YORK



**CLEVELAND INTERESTED IN MUSIC**  
(Continued from page 225)

out how such a method increases sales and "makes dealers' cash registers ring." Says the organ: "Millions of dollars were spent last year by talking machine dealers, in the newspapers, magazines, billboards, trades papers, street cars and certain forms of direct-by-mail advertising. It has been brought to the highest state of efficiency. The only form of advertising that has not kept pace with the general advertising stride has been window and store display. It is only in the minority of instances that the dealer has come to appreciate the tremendous selling value and advertising power of a store window.

"There is no form of advertising so rich in possibilities from every angle as window display. Arthur Freeman, the noted advertising writer, says 'The best place to advertise is the place where the merchandise is.'

"In no other line of business does the window lend itself more effectively for this purpose than it does in the talking machine trade. And especially is this true with Victor products. The Victor trademark, which has cost so many millions of dollars to establish, is so well known and readily recognized that half of the idea to be put across is already accomplished.

"But window advertising can be just as ineffective as any other sort. It must be studied and worked out systematically in order to produce maximum results."

The Wurlitzer Co. is carrying large newspaper advertisements featuring a special sale of the stock taken over when the Caldwell Piano Co. closed out its store, March 1. A large line of talking machines are featured.

The B. Dreher's Sons Co., which recently acquired a new store building in Huron road, a short distance "down the road" from its junction with Euclid avenue and East Fourteenth street, has been offered \$300,000 for the building. The Dreher's contracted to pay \$225,000 for the structure, now known as the Winton auto sales service station.

The appearance of John McCormack in a postponed recital at the new Masonic Temple auditorium and three concerts by the Chicago Orchestra Association in the same hall created a big demand for records reproducing selections by the association stars and McCormack. Seats for all three concerts were sold out.

All of Cleveland's talking machine retailers featured Easter with special window attractions and displays of records appropriate for the sea-

**C. M. GOLDSTEIN**  
Consulting Engineer

20 Years' European and U. S. Experience  
5 Years with Columbia Graphophone Co.

Raw Materials  
Recording  
Record Manufacture  
Talking Machines and Parts  
Patent Information

Room 1621  
111 Broadway  
New York

Strictly confidential advice. A-1 references.

son. Some of the window decorations were unique. The Eclipse Musical Co. exhibited a Victrola in a huge white egg shell, the machine

being exposed to view through a big crack in the shell. Easter music, reproduced in records, found an unusually big sale.

**BUST OF TITO SCHIPA FINISHED BY BROOKLYN SCULPTOR**

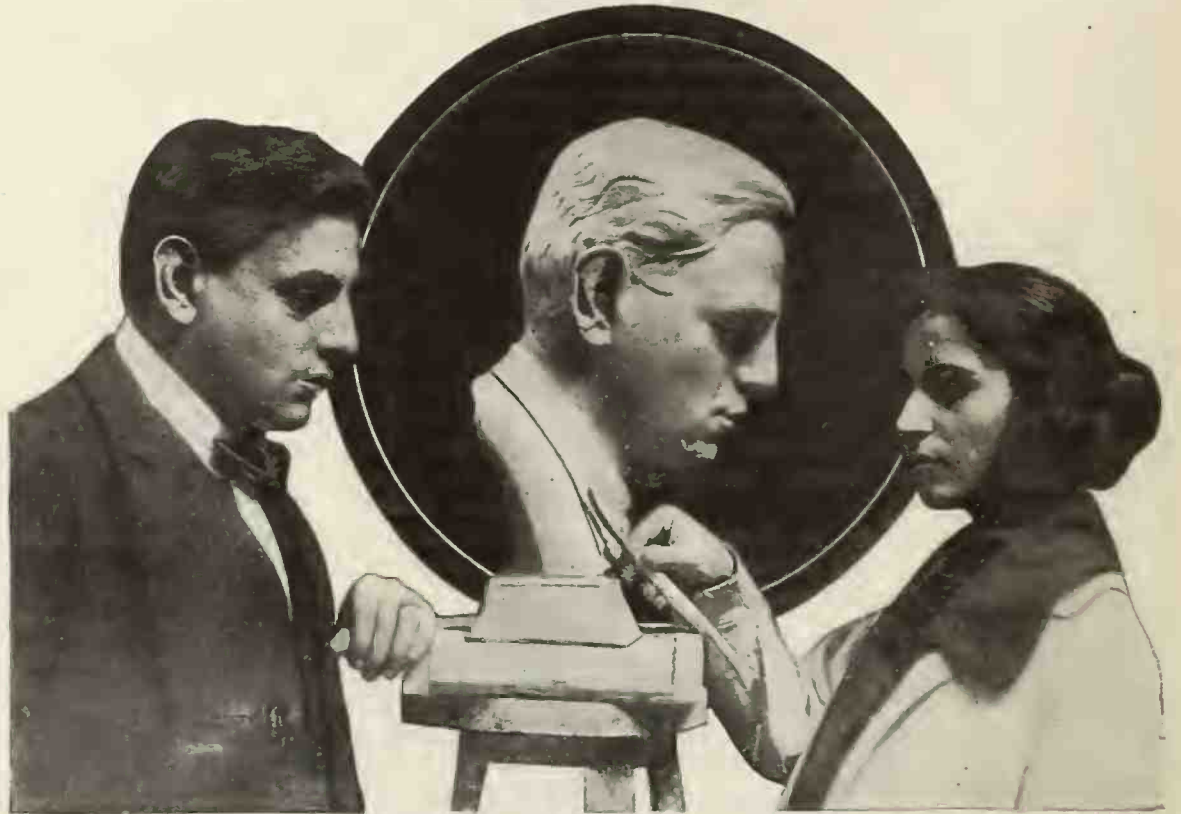

© A. B. Bogart

Miss Clara Fassano Modeling Bust of Tito Schipa

Miss Clara Fassano, the talented young Brooklyn sculptor, has recently completed a striking and life-like bust of Tito Schipa, the famous lyric tenor of the Chicago Opera Company, and the artistic and faithful manner in

which she has executed her work has won high praise from both the critics and admiring public.

Tito Schipa, whose triumphs as an opera star created such a sensation in musical circles and whose marvelous voice is duplicated exclusively on the Pathé phonograph records, has had a most interesting career. Before his American debut, when he took the public by storm, he was for several years the most popular and fascinating young tenor in Italy's leading opera houses and ere his beautiful voice had fully matured he won high honors as a musician and composer, so that he is equipped with the most valued attributes of his art, matched with youth and a charming personality.

**INTRODUCING NEW SPECIALTIES**

Brown-McManus & Co., the well-known jobbers of the "Crippen Interpretone," recently forwarded to over a hundred of their dealers samples of the above machines, closely following which their representatives called in connection with the initial demonstrations.

Brown-McManus & Co., who also have a Boston office at 41 West street, that city, are carrying on their sales and advertising campaigns from both centers. They recently took over for distribution the "Portrola" a new portable phonograph of much merit. They are shipping Operaphone records to the trade in quantities, and in this they are not confining their activities to any given territory. In addition they are giving much of their attention to their new "Trimpoint" steel needle.

The National Furniture Co., Washington, D. C., has established a large talking machine department and has added the Pathéphone.

Room No. 321  
New York City

130 Fulton Street  
Phone, 2812 Cortlandt

Clifford A. Wolf

MANUFACTURER OF

Diamond and Sapphire  
Phonograph Points



**LOESER & CO. FEATURES THE SONORA**

Brooklyn Department Store Presents That Line in Full Page Advertisements

In the daily papers last week Frederick Loeser & Co., the prominent department store of Brooklyn, N. Y., carried most attractive full page advertisements setting forth the fact that beginning April 8 they would have for display and sale a complete line of Sonora talking machines. Four of the leading styles of Sonoras were illustrated in the advertisement, which was of distinctly high-class character in every particular and made the appeal on quality rather than price. The definite statement was made "You cannot buy a Sonora for \$5 cash and \$5 monthly. It is not that kind of an instrument." There was then offered a complete description of the various features of the Sonora line.

**AN IMPORTANT ACCESSORY HOUSE**

Valentine Kusnitz, of St. Louis, Is Building Up an Excellent Repair Trade, Not Only in That Territory but Throughout State

St. Louis, Mo., April 8.—The Val Accessory House, of 1002 Pine street, this city, is a large development of the activities of Valentine Kusnitz, a man of long and practical experience in the talking machine business. Mr. Kusnitz is now handling in a wholesale way orders from dealers for repair parts of all machines, even the old ones not now on the market. He also has a line of motors, tone arms and sound boxes and other supplies. Mr. Kusnitz is to be congratulated on his keen perceptions which have brought him to a realization of the needs of the dealers in this section of the country.

Guy—What do records cost nowadays?

Mabel—Well, sir, for fifty cents you can have "Smiles"; for a dollar, "Kisses"; and for a dollar and a half "You'd Be Surprised."—Tiger.

**GOOD PATHE TRADE IN NASHVILLE**

Gray-Dudley Hardware Co. Finds Pathé Department an Important Business Feature

NASHVILLE, TENN., April 6.—The Gray-Dudley Hardware Co. of this city, one of the biggest wholesale concerns in the South, and whose slogan is "The Big House in the Heart of Dixie," distributes the Pathé on a very extensive scale. The company has something like thirty-five general salesmen, besides quite a few specialty men and the sales are rapidly increasing from month to month. The Pathé department is a hobby with W. C. Pollard, one of the principals in the house, and W. T. Crockett is the manager of the department. He has the close co-operation of H. D. Bozeman, who conducts the mail order department (to the dealer only). The Pathé business is considered one of the important departments of this house.

**BECOME PARAMOUNT DISTRIBUTORS**

The Northwest Phonograph Jobbers, Inc., Spokane, Wash., have been appointed distributors for the products of the Paramount Talking Machine Co. in the States of Washington, northern Oregon, northern Idaho and western Montana. H. C. Kent, the head of this company, is well known in commercial circles in the Northwest. Lance E. Hull has been placed in this territory by the Paramount Talking Machine Co., as factory representative, for the purpose of co-operating with the new jobbers in rendering the dealers efficient service.

**D. E. WHEELER JOINS EDISON CO.**

Daniel Edwin Wheeler, formerly associate editor of the Popular Magazine, has been appointed editorial director in the advertising department of Thomas A. Edison, Inc. He brings to his new position a wide experience in the literary world, as well as professional musical knowledge.

**TRI-SALES CO. EXPANSION**

Details About New Patented Product of Interest to the Trade May Soon Be Announced

ST. LOUIS, Mo., April 8.—J. H. Phelps, general manager of the Tri-Sales Co., of this city, announces that they will soon be able to tell the trade about a new patented product which will be of vital interest to talking machine dealers and owners everywhere. Mr. Phelps returned from a trip to Chicago last week in order to complete arrangements for some additions to their line of supplies and accessories.

This company, under the presidency of H. T. Mayer, has built up a really remarkable business on the Portophone, a small but very efficient portable phonograph, which folds up into grip form to be carried around without your knowing you are doing it. Under the energetic efforts of the Tri-Sales Co. it has proved a big seller among the dealers in the fourteen States in which the company work. They have eleven salesmen covering this territory.

**EDISON ARTISTS IN ST. LOUIS**

St. Louis, Mo., April 8.—Another Edison tone test was given Saturday night, April 3, at Sheldon Auditorium by Claire Lillian Peteler, soprano, and Miss Sybil Sanderson Fagan, whistler, under the direction of Mark Silverstone, president of the Silverstone Music Co. In spite of adverse weather conditions there was a large attendance. Unstinted approval was given to artists and instrument. Willard Osborne played with two selections on the violin to demonstrate the perfect re-creation of the true violin tones.

Albert Sichel, who for many years has conducted a retail store at 219 West 125th street, New York, is arranging to move to new and larger quarters a few doors from Seventh avenue on the same street. This establishment is now being fitted up very handsomely.



A WALNUT PHONOGRAPH CABINET

**AMERICAN WALNUT**  
 "The Cabinet-wood Superlative."

**For Phonograph Cabinets**

The qualities that make American Walnut supreme among the world's cabinet-woods are not debatable. They need no argument. Everybody knows. And everybody has known—back to the earliest name in your own family record.

DOES YOUR LINE MEET THE DEMAND created by our big national advertising campaign for high-grade furniture of American Walnut?

*Interesting data for manufacturers and dealers on request. Write us for a copy of the New Book on American Walnut. (Valuable.)*

AMERICAN WALNUT MANUFACTURERS' ASSOCIATION  
 Room 1022, 616 So. Michigan Boulevard, Chicago



# *You Ought to Know*

In case you are contemplating expanding the sphere of your business to include departments devoted to Pianos, Player-Pianos, Musical Merchandise or Sheet Music, that you'll find news and comments about them all in



ESTABLISHED 1876

The oldest and leading music trade weekly, which covers every branch of the industry.

## **It Contains**

*instructive and educational articles. Hints on salesmanship and advertising. Editorials that are timely and authoritative. Facts about the new things in the trade. Trade happenings in all parts of the United States.*

***“Review the Music Trade With Us”***

*Send your \$2 now for a full year's subscription to*

**THE MUSIC TRADE REVIEW**  
373 FOURTH AVENUE  
NEW YORK



## DISCUSS SHORT TIME VS. LONG TIME SALES IN PORTLAND

With Increased Supplies of Talking Machines, Sales Methods Are Now Up for Discussion—  
Leading Dealers in Portland and Vicinity Well Pleased With Business Prospects

PORTLAND, ORE., April 5.—A "Merry War" or a good-natured rivalry, as some choose to call it, is going on among the talking machine dealers this month. Some of them have been having special price sales, offering machines for small first payments and very small monthly payments. Other dealers protest against this method of securing trade—insisting upon regular methods—good first payments and large monthly payments which they declare were agreed upon by dealers at the meetings of the Portland Talking Machine Dealers' Association, which, however, is apparently defunct, as no meetings have been held for about a year. Some of the conservative dealers insist that special sales are detrimental to the business; that good first payments and good monthly payments assure a class of trade worth while. On the other hand, many of the most reliable dealers in the city are advertising machines, offering them for \$5 down and \$5 a month and some of them offering them for \$1 down and \$1 a month. There is no doubt that this has temporarily increased the sales of those houses pursuing this method, but whether final results will be satisfactory remains to be seen. Hyatts, Bush & Lane, Reed-French Co. and Eilers all approve of these special inducements, considering them good business.

The Reed-French Co. believes that special sales whereby instruments can be bought for \$1 down and \$1 a week payments are profitable, as by this manner a large number of small machines have been disposed of and the buyers are purchasing records so fast that it is hard to supply them. A big business in the talking machine department has been the result of the experiment and not alone low-priced machines have been purchased. The month has been a remarkable one all through. The record rooms did a business that has not been equaled for some time. The percentage of cash sales is as large as ever.

E. W. Barlow, manager of the Pacific Phonograph Mfg. Co., which manufactures the Stradivara phonographs, has just returned from a visit to New York, Chicago and Grand Rapids. He visited factories in Chicago and Grand Rapids, being particularly interested in motors and tone arms. While enormous strides have been made in the talking machine business since his last visit to the East, he found the situation very acute in the manufacturing end, and he believes that there will be a great shortage during the Fall and Winter and necessarily an increase in prices. The price of shellac has increased so much that manufacturers of records have found it absolutely necessary to increase their prices. A striking feature, said Mr. Barlow, is the great improvement in motors.

In the Stradivara factory many innovations have been introduced tending toward the improvement of the plant and the happiness and well being of those connected with it. A social organization, known as the "Stradivarians," is one of the new features. Various interesting details of the business are discussed at the monthly meetings and a general good time indulged in. It is planned by the company to provide a library for the benefit of the employes. A paper called the "Stradivara Record" is another special feature. Items of interest pertaining to personal affairs as well as factory matters will be printed. The employes appreciate the efforts made by the Stradivara people to make their work enjoyable as well as productive and the "Stradivarians," which include officers, clerks, workmen and their families, is a lively and popular organization.

Frank M. Case, manager of the Wiley B. Allen Co., has had a two weeks' vacation which he spent in California. He, in company with Frank Anrys, general manager of the Wiley B. Allen Co.; Mrs. Anrys, James Black, treasurer of the company, and Miss Mae Shintaffer, of the mail order department, went from San

Francisco to Los Angeles, and on the return trip motored from Los Angeles to San Francisco by the coast road, stopping at Santa Barbara and other interesting points on their way. Mr. Case reports excellent business in the Portland house.

The Columbia Graphophone Co. is never behind when it comes to demonstrating modern ideas. It is showing a "Model Store" in Seattle which is attracting the attention as well as the admiration of the dealers. This "Model Store" is shown in the wholesale building and is a marvel of efficiency, expediency and artistic effort. Dealers are expected to study the arrangement and as far as practicable arrange their stores in a similar manner.

The new manager of the talking machine department of the Meier & Frank Co., Lester S. Shroeder, is already planning great improvements for his department. The Vocalion line has been added to the department now handling the Victor, Columbia and Edison machines. Mr. Shroeder has some splendid plans prepared for improving and remodeling the department. No expense is to be spared and after the elaborate plans have been carried out there will be no handsomer department in the West.

Records which may be borrowed by schools for educational purposes will be added to the central public library if certain plans discussed by the directors mature. A request from the State music teachers brought the matter to the attention of the directors. The music teachers are working on a plan to have each public school supplied with a talking machine. It will be of great advantage to the schools if the plan suggested is carried out.

The Pacific & Accessory Supply Co., which was considered by the investors a rather small affair, has grown to such an extent during the last few months that it has been recapitalized,

and it is now double what it was originally. The new manager, C. D. Wood, has returned from a recent visit to the East, where he made some valuable connections in accessory lines. In addition to the present stock of phonograph supplies, it is the intention of the company to add band instruments and all kinds of small goods. Emerson records are so much in demand that to fill the orders is an impossibility.

The Bush & Lane Piano Co. has appointed H. T. Campbell manager of the local branch of the company. Thomas Wilkinson, who has been manager for about eight years, has severed his connection with the company. Mr. Campbell comes from the Seattle branch, where he was sales manager; H. A. Smith, who has been sales manager of the Portland branch, will take Mr. Campbell's place in Seattle. H. T. Campbell was presented by the employes of the Seattle house with a handsome Masonic emblem before leaving that city.

The big trade in talking machines continues at G. F. Johnson's. In a single day twelve machines were sold, the aggregate sales for the department that day being in excess of \$2,500.

The Cheney Phonograph Co. has been incorporated under the laws of Oregon. The concern will have a capital of \$60,000, with main offices in Portland. It will handle in a wholesale way the Cheney phonograph in Oregon, Washington, Idaho and Montana.

Miss Jessie A. Meighen, now with the Reed-French Co., has sent out cards to her many friends and patrons announcing her connection with that company.

M. Seller & Co., the Northwest distributors of the Pathé, report a steadily increasing demand for Pathé records and phonographs, but on account of scarcity of stock are having difficulty in keeping up with orders, due to the universal shortage.

M. W. Davis, manager of the Brunswick Co., who recently visited Eastern cities, has just recovered from a severe illness and is now in eastern Oregon establishing Brunswick agencies and visiting dealers.

# "LIBROLA"

A Library Table PHONOGRAPH at a Reasonable Price

Two thirds of top is stationary, no need to move anything when playing phonograph.

Fully equipped to play all disc records, satisfaction guaranteed.

62% re-orders to date.

Write for prices and exclusive territory.



No. 250T. Patent applied for.  
48" long, 28" wide, 31" high. Finished all around  
Mahogany or Walnut

SEABURG MANUFACTURING COMPANY  
JAMESTOWN, NEW YORK



## The Romance of Adora

### A New Phonograph with a Remarkable Sales Record

Slightly over a year ago the first ADORA phonograph was offered for sale in Detroit.

It was marketed with an entirely new idea, namely, of selling the finest phonograph that could be produced at a price within the reach of the average buyer.

The ADORA embodies certain new and patented improvements in tone chamber and tone arm construction which give it a decided advantage over any other phonograph in quality, clearness and volume of tone.

When these tone qualities were officially tested before musical critics and experts, in comparison with nationally famous and much higher priced phonographs, the ADORA created a sensation.

The critics were unanimous in the opinion and declaration that the ADORA was the finest, clearest, fullest toned phonograph they had ever heard—bar none.

And the Detroit public was equally quick to recognize this important fact. So quickly did the fame of this remarkable instrument spread that the factory was kept busy filling local orders.

From a beginning of practically nothing, within one year's time, more than four thousand ADORA phonographs have been manufactured and sold to the Detroit public.

By more than doubling our manufacturing facilities, we will be in a position shortly to offer these instruments for sale through reputable dealers throughout the United States.

Judging by the response to its appearance in Detroit, the ADORA will enjoy an equally successful sale when it is marketed nationally.

Because the ADORA is unquestionably a step forward in phonograph progress, and a revolutionary improvement over any other phonograph offered for sale.

**Adora Phonograph Co.**  
242 Jefferson Ave., East  
Detroit, Michigan

## PERRY B. WHITSIT CO.'S NEW WHOLESALE VICTOR HOME

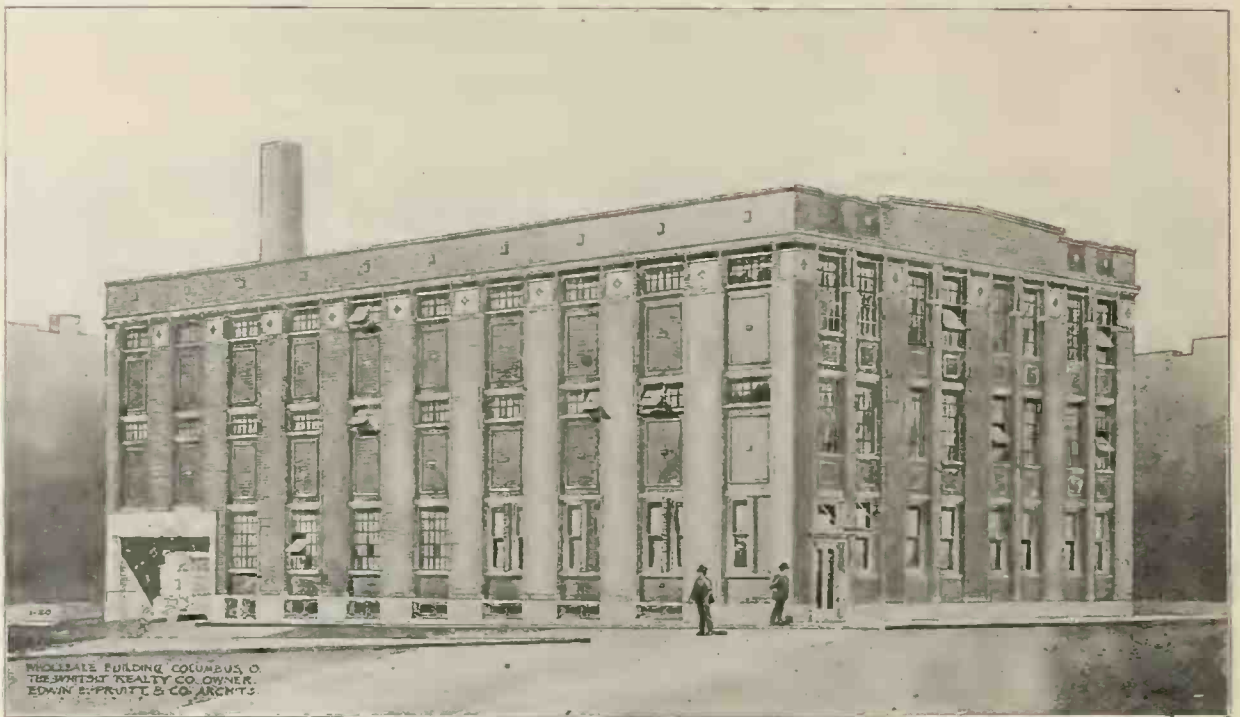

Through the courtesy of the architects, Edwin E. Pruitt & Co., of Columbus, O., we are able to present an illustration of the building now under construction for the Perry B. Whitsit Co., Victor distributors in that city.

### JUNE 6 FOR AD CLUBS' CONVENTION EXTENSIVE PARAMOUNT TERRITORY

No matter how successful the advertising system employed by any business house may be, it never is perfect. Constantly changing conditions among consumers demand corresponding changes and modifications in producing and selling methods, according to Charles H. Mackintosh of Chicago, who is chairman of the national exhibits committee for the sixteenth annual convention of the Associated Advertising Clubs of the World at Indianapolis, June 6 to 10.

Recognizing the fact that the small advertiser—who cannot afford to experiment extensively—can learn much from the national advertiser's time, money and labor-saving devices, and that the big advertiser can get new glimpses of human nature from his little brother who comes in closer personal contact with his customer, the exhibit committee is arranging for an extensive display.

#### HARGER & BLISH NOW WHOLESALE

Harger & Blish, Inc., Edison jobbers of Des Moines, Ia., have found their Edison wholesale business growing so rapidly that they have decided to relinquish the retail end of their establishment. The Massey Piano Co. will become the Edison retailers.

#### AN ORIGINAL WINDOW DISPLAY

DeForest Store in Warren, O., Makes St. Patrick's Day Display Sell Records

An unusual and very attractive St. Patrick's Day window display recently appeared in the

It was announced this week that the Peck & Hills Furniture Co., New York, which was recently appointed distributor for the products of the Paramount Talking Machine Co., will cover as its territory from its New York headquarters the States of New York, New Jersey, eastern Pennsylvania, Delaware and Maryland. The company has four other stores, which are located in Chicago, Denver, San Francisco and Los Angeles, and from its San Francisco store it will cover the States of California and southern Oregon.

P. H. McCulloch, Paramount factory representative, will co-operate with Peck & Hills by rendering service to the dealers in New York and southern New Jersey. C. F. Adams, Paramount factory representative, will co-operate with the trade and the jobber in eastern Pennsylvania, southern New Jersey, Delaware and Maryland. E. E. Graham, Paramount factory representative, will occupy a similar capacity in the territory handled from the Peck & Hills' San Francisco store.

Edward Caldwell, a Victor dealer of Stoneham, Mass., has increased the equipment of his store by adding three Unico booths together with Unico record racks.

Cormack appeared in the central display and his records were grouped about him. Around the picture was a large frame of green, which, when illuminated at night, brought forth a large number of shamrocks. All of the records that were featured were appropriate songs, such as "Tumble Down Shack," "Song of

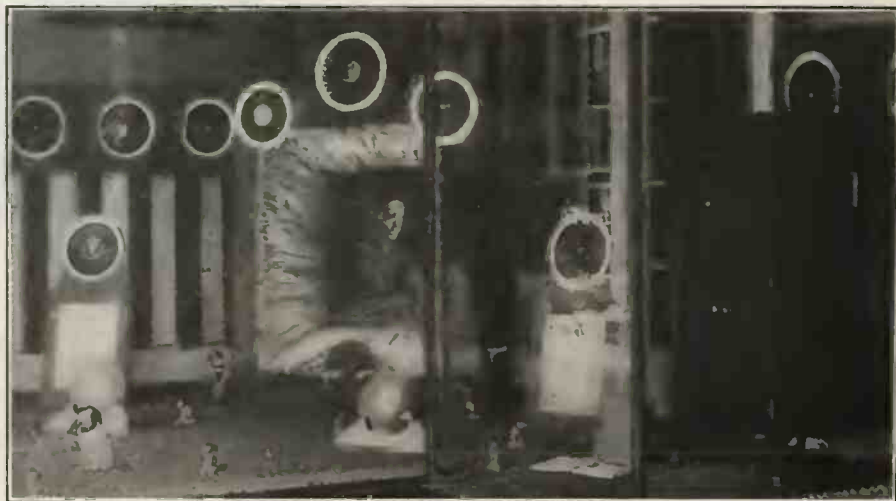

Window Display at DeForest Store Featuring Victor Records

DeForest Pioneer Music House, Warren, O. This window was prepared by R. N. Markley, manager of the store. As the accompanying photograph shows, a large picture of John Mc-

Songs," and like numbers. These records were mounted with a green border. Small Victor dogs with chains of green and white ribbon stood in front of the picture.



## STRIKING BRUNSWICK POSTER FOR USE IN STREET CARS

The Brunswick-Balke-Collender Co. have prepared for the use of their distributors and dealers a most attractive street car card that is also adaptable for showroom and window display. The card features both the Brunswick

right is shown one of the popular types of Brunswick phonographs. The name Brunswick phonographs and records appears prominently in the center of the card under the slogan, "Hear—then compare." Room is left for the



Reproduction in Black and White of Brunswick Poster

phonograph and the Brunswick record. On the left is a half-tone picture of the Brunswick girl standing entranced over the music of the phonograph, while immediately underneath appears a reproduction of the Brunswick record. On the

name and address of the distributor or dealer. The illustrations are in sepia and the printing in black over a lavender tint block. The accompanying illustration gives some idea of the attractive appearance of the card.

### TRADE NEWS FROM BIRMINGHAM

Preparing for Convention of Victor Dealers in May—Bromberg Expansion—Banquet of Victor Association—Emerald Booms Vocalion

BIRMINGHAM, ALA., April 7.—Dealers in this vicinity are now preparing for their second annual convention, which convenes here on May 6 and 7. This convention is to be held under the auspices of the Southern Victor Dealers' Association, which Association now covers nine Southern States. Several Victor officials will be in attendance as well as representatives of trade journals and many accessory manufacturers. The Birmingham Victor Association has planned many entertaining features for the visitors and a pleasant and profitable visit is promised all those dealers who will attend. Owing to the extremely congested condition which exists throughout the country as regards hotel accommodations, the local committee are very much concerned as to whether or not the hotels here will be in position to accommodate all the guests. They point out that reservations should be made at once, otherwise there will be disappointment. According to present plans the principal addresses will be made by F. A. Delano, in charge of the Victor salesmanship courses, and Mrs. Frances Elliott Clark, head of the educational department.

The Birmingham Victor Association held its second banquet at the Hillman Hotel on March 30. Every Victor dealer in the vicinity was present and with the exception of two or three every member of the Association was seated around the horseshoe table which held forty-two. A. R. Boone, president of the Birmingham Victor Association, acted as toastmaster. During the evening Abe Williams entertained the diners with several vocal selections and several selections on the ukulele. John M. Goude-lock recited in a very interesting way many of the incidents of his recent course in salesmanship at the Victor factory, which he thought would be of interest to the members. Ben Hammond told the dealers of what he had learned at the Victor factory on his recent trip there regarding production. The Association voted to meet each week from now until after the convention of the Southern Victor Dealers' Association.

Reid Lawson, distributor for Playerphone talking machines and Okeh records, reports a very brisk business for this season. Mr. Lawson also conducts a retail establishment in his jewelry rooms on the fifth floor of the First

National Bank Building. He has several trucks that scour the district around Birmingham and few sales get by this live and energetic dealer.

Bromberg & Co., Aeolian and Columbia dealers, report a 100 per cent increase in record sales since the installation of Earl Silliman as manager of their phonograph store. Mr. Silliman has had a wide experience, having been connected with the Columbia Graphophone Co., in its stores in Boston for a number of years.

The Emerald Co., Vocalion distributors, now have several men on the road looking after the

increasing trade of this progressive house. They have recently established an accessory department and are now in position to supply their dealers with every phonograph want.

Mrs. Myra Treadwell has recently returned from Jacksonville to resume her duties with the Cable-Shelby-Burton Piano Co.

Mrs. Mattie Wright, saleslady for Bromberg & Co., recently underwent a serious operation and her many friends in and out of Birmingham will be glad to know she is improving.

R. P. McDavid, secretary of Clark & Jones Piano Co., Victor dealers, has recently returned from a visit to Atlanta in an effort to secure some goods. Mr. McDavid states that he is very well satisfied with the development of Birmingham after looking over the Georgia metropolis.

All Victor dealers are very jubilant over the apparent increase in the production of Victrolas. The cry still seems to center over the record situation, but all are living in hopes that the Victor Co. will soon be in position to supply greater quantities of the more salable records.

### KEMENY VS. VICTOR SUIT

Treble Damages Asked in Suit Under Clayton Act Results in Verdict for \$2,000

A verdict has just been handed down by the jury in the United States District Court for the District of New Jersey in the suit of Louis Kemeny vs. The Victor Talking Machine Co. The plaintiff was formerly a dealer in Victor goods at Perth Amboy and sued for \$300,000 as treble damages under the Clayton Act, alleging that his supply of Victor merchandise had been cut off.

After a trial extending over almost two weeks, the plaintiff was awarded as treble damages the sum of \$2,000. It is understood that the Victor Co., while it won a substantial victory in the amount of the verdict, will nevertheless appeal the case to test the legal questions involved.

## Improve Your 1920 Production WITH PARR PRODUCTS

The Solution  
of True  
Reproduction  
of Tone  
Qualities

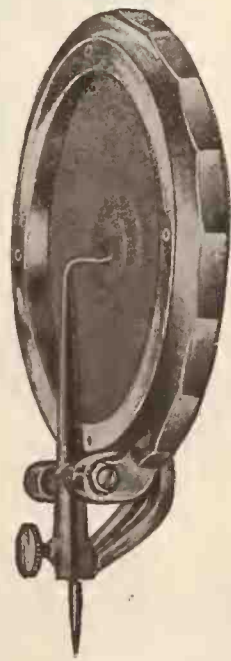

Factories  
New York City.  
Latrobe, Pa.  
Newark, N. J.

OUR MAGNETIC REPRODUCER: Produces pure tone qualities and wonderful volume. The method of constructing the reproducer and the pivotal arrangement of the stylus bar allow the vibrations to pass without interruption from the needle to the diaphragm. The magnetic attraction of the needle arm gives an outward strain on the diaphragm, making it more sensitive to vibration influences.

THE UNIVERSAL TONE ARM: The only arm on the market with an automatic change of weight. The weight to play either vertical or lateral cut records is automatically and accurately changed. It centers in either position. Our new and improved arm is made entirely of brass, producing a rich, mellow tone and presenting a neater and more beautiful appearance. Can be furnished in any length desired.

OUR VIBRATONE DIAPHRAGM: Eliminates the troubles encountered with mica; is light, elastic and flexible; will not crack, blister or develop inequalities. Produces a more beautiful tone and greater volume. Not affected by atmospheric changes.

## Parr Manufacturing Corporation

MAIN OFFICES:

100-108 WEST 23rd STREET

NEW YORK CITY



# IMPORTANT NOTICE

## TO THE AMERICAN TRADE

**The Sterno Manufacturing Company**  
19 CITY ROAD . . . . . LONDON, E. C. ENGLAND

Manufacturers of the world known COMPACTOPHONE—the most complete portable gramophone extant—beg to announce the conclusion of arrangements for the EXCLUSIVE SELLING RIGHTS IN THE UNITED STATES OF THE

**High Grade Motors** <sup>Manufactured</sup> **By** **Mermod Freres** <sup>St. Croix</sup> <sup>Switzerland</sup>

### WONDERFUL MECHANISM

These motors represent the acme of workmanship and quality. Each part is made to the finest gauge limits and assembled to run with the precision of a watch—silent and true. Messrs. Mermod Freres is an old established Swiss manufacturer. Back of their motors are years of hard practical experience. The experimental stage was left behind a decade or more ago. Reliability and quality are therefore assured.

### DIFFERENT MODELS

Mermod Freres motors comprise several types—single and double spring worm and pinion-gear drive, the very latest and scientific method of construction.

### CONSULT US

Before placing your orders elsewhere consult us as to prices and terms of trading. We are out for quick shipments and prompt delivery direct from the factory to the buyer.

### SPECIAL TERMS TO JOBBERS

Within the near future it is proposed to establish  
**A CENTRAL DISTRIBUTING DEPOT IN NEW YORK**  
Meanwhile trade inquiries should be directed to

**THE STERNO MANUFACTURING CO.**  
19 CITY ROAD . . . . . LONDON, E. C., ENGLAND



## Snare Drum and Trap Cases

Made of vulcanized fibre, with tray and partition, fibre corners, cowhide handle, heavy brass trimmings. Any size. This case will last a lifetime and the price will surprise you.

We are manufacturers of all kinds of Musical Instruments, Cases and Covers. Write for Catalogue and Prices.

HARD FIBRE RECORD CARRYING CASES A SPECIALTY

J. D. HUNT MANUFACTURING CO., Indianapolis, Ind.

"A SAMPLE WILL CONVINCCE YOU"



No. 1078-A

## MARCH PROVED AN EXCEPTIONAL MONTH IN BALTIMORE

Increased Business Registered Despite Stock Shortage—Contract Let for Portion of New Columbia Co. Plant—Victor and Columbia Dealers Hold Interesting Meeting—General News

BALTIMORE, Md., April 8.—March proved to be an exceptional month for business with the talking machine dealers in the Baltimore territory, and all of them report fine business and increases over the same month of a year ago. These increases came about despite the shortage of product, for few dealers were able to obtain all the records they desired in their lines and although the shipments improved they did not meet the demand. Dealers are looking forward to a big business in April, for they feel that the increase in record shipments will continue to grow.

From a local standpoint, one of the biggest events to local dealers was the awarding of the first portion of the contract by the Columbia Graphophone Co. for construction of its factory here. This contract is for the first units of the factory, which will eventually occupy 110 acres at Orangeville, in the eastern section of the city.

Both the Victor and Columbia dealers planned interesting and instructive meetings during the month. The Victor meeting for this month, which will be held at the Emerson Hotel Wednesday, April 21, will have as its chief attraction E. J. Dingley, of the Victor factory. Already more than 100 persons have signified their intentions of attending the gathering. The Columbia meeting will be held at the Southern Hotel, April 13, the program for the occasion not being announced as yet.

The March meeting of the Victor Talking Machine Dealers' Association of Baltimore was an enthusiastic one. Many interesting things were discussed and an elaborate plan of bringing to this city the leading Victor stars was decided upon. This program will be put into effect in the early Fall and a committee is already at work on the project. Another plan which will be undertaken in the Fall will be a co-operative scheme of advertising, which will have for its keynote "Victor service" and all that it means. These ads will bear only the name of the association and an insignia of the association. The ad will set forth that the insignia on the show windows and on the literature of all kinds will be a mark to identify these Victor firms. It is also planned to invite the various nearby dealers of the State to join the association and eventually the association may become a State-wide organization.

"March was a wonderful month with us," said W. S. Parks, the local Columbia manager, "and it has only been exceeded by one month's business and that was last December." Columbia product came in better, especially the records, and many dealers were able to have some of their back orders filled. Many dealers attended the Columbia gathering last week and were able to hear the new records and also listened to some very instructive sales talks.

During the month Mr. Parks visited New York and a number of points in Virginia and reports business booming through those sections. Mr. Parks left for New York City to-night. He is still hard at work seeking to obtain a better local headquarters with more room.

Sales Promotion Swartz, of the Columbia service department, says that many dealers were able to get their back orders cleared up to a large extent, and while all of the back orders could not be filled he believes most of the dealers were satisfied. "Venetian Moon" and Bert Williams' "Moonshine on the Moonshine" were among the big sellers during the month.

E. C. Daniels, of Debulon, N. C., and Mr. Zeiler, of Berkley Springs, Va., were among the visitors to Columbia headquarters during the month. W. T. Sibbetts, formerly of the Columbia sales staff, has the first two of his chain of stores in operation at Cambridge and Salisbury, Md., and reports very good results.

Elmer J. Walz, sales manager for Cohen & Hughes, Victor distributors, reports good business for March with a slight improvement in the receipt of records. A very interesting recital was held by the firm at its headquarters at which the various dealers attended and new records were demonstrated. Among those who attended was Miss Morgan, of M. Nathan, Cam-

bridge. Mr. Walz says the monthly recitals for the Cohen & Hughes customers, which are always preceded by a luncheon and followed by a dance, while the dance records are being demonstrated, are becoming more and more popular each month. Mr. Walz, together with I. Son Cohen, attended the meeting of the National Association of Talking Machine Jobbers which was held in New York recently.

W. C. Roberts, manager E. F. Droop & Sons Co., Victor distributors, says business held its own for March, but expects to receive more goods for April. He says the business is to be had and it is only a question of obtaining goods.

William A. Eisenbrandt, of H. R. Eisenbrandt & Son Co., Victor distributors, says business is showing improvement and he believes it will continue to improve. He attended the jobbers' meeting in New York last week and also visited the Victory factory and says that, while he has no official information on the subject, more goods will very likely be coming through from now on.

The Clarke Music Co., distributor for Emerson records, reports a great business in March and expects to see April show even to bigger advantage. Eddie Cantor and Scanlan, two of the Emerson artists, will be in Baltimore the week of April 19 and will very likely spend a little time at some of the houses handling the Emerson line.

The National Piano Co., Pathé distributor, reports big business during the month with an increase of receipts. Jesse Rosenstein, of the company, has just returned from a visit to Chicago and Detroit.

Many attractive Easter windows were noted among the trade. The G. Fred Kranz Music Co. had one of the most attractive. A vernis martin model Victrola was the center of the display, with a profuse decoration of Easter flowers tastefully arranged. The Rosenstein Piano Co., Columbia dealer, used a large rabbit on top of a Grafonola with streamers to other models and Easter flowers distributed about. Robert Ansell, Inc., had a special record display with an abundance of Easter flowers entwined about the record easels.

Hammann-Levin Co. filled an extraordinarily large show window with Victrolas IV and VI with the result that a great deal of business was developed for this type of machine.

The New England Piano & Phonograph Co. has opened a branch store in Manchester, N. H., under the name of the Manchester Music Co.

## Phonograph Hardware —of Ultra Quality—

DISTINCTIVELY DESIGNED

including:—

—FOR IMMEDIATE DELIVERY—

Needle Cups and 3,000 Double Spring Motors capable of playing three 12-inch records.

Also—

Lid Supports, Automatic Stops, Tone Rods, Knobs, Escutcheons, Sockets, etc.

Delivered with reasonable promptness.

Hardware  
for Furniture and Refrigerators  
Smartly, durably and practically built.  
Samples promptly furnished on request.

—Grand Rapids Brass Company—  
Grand Rapids New York, 7 East 42d Street Michigan



### WORLD'S CLASSIFIED ADVERTISING

Any member of the trade may forward to this office a "Situation" advertisement intended for this Department to occupy a space of four lines, agate measure, and it will be inserted free. Replies will also be forwarded without cost. Additional space will be at the rate of 25c. per line. If bold faced type is desired the cost of same will be 25c. per line. Rates for all other classes of advertising on application.

**WANTED**—An experienced talking machine salesman, with executive ability; good opportunity to the right party. Address Saul Birns, 111 Second Ave., New York City.

**WANTED**—Experienced and competent Victor record salesman or saleswoman. Apply in own writing, stating with whom formerly employed, how long and in what capacity. Also give age, nationality, salary required and references. Address Baumer Piano Co., New Rochelle, N. Y.

**WANTED**—Several competent phonograph salesmen to sell Edison Disc Amberola and Sonoras. Furnish auto to responsible men. Also experienced repair man wanted. Wonderful field to work. Fine proposition to live wires. Address Levy's, 316 Second St., Macon, Ga.

**RECORDING** laboratory expert, 9 years' experience, conversant with processes of Victor and leading manufacturers, will completely or partially equip to produce lateral-cut records equal to best in quality and surface. Consultations for improvement of product. Address E. A. Pancoast, Oak Lane, Philadelphia, Pa. Phone Melrose 1376W.

**EXPERT REPAIRMAN**, 15 years' experience on all makes, desires position with a reliable concern. Address "Box 777," care The Talking Machine World, 373 Fourth Ave., New York City.

**WANTED**—Salesmen in each State to sell a high-class reproducer that fits all types of talking machines. Commission basis only. Address "Box 778," care The Talking Machine World, 373 Fourth Ave., New York City.

**SUPERINTENDENT WANTED** in factory making high-grade phonograph motors, tone arms and finished machines; located within fifty miles of Chicago. Only high-grade men who can show a clean record need apply. Must be a worker and fully competent on all manufacturing operations, automatic screw machines, tools, dies, punch and drill presses, assembling, cost and production: If you are looking for a real opportunity to become permanently connected with and interested in a small growing concern this is your chance. If you are only looking for a job, do not reply. State age, nationality, religion, your experience in detail for the past five years and wages expected to start. Address "Box 779," care The Talking Machine World, 373 Fourth Ave., New York.

**SALES MANAGER WANTED**—Prominent manufacturer of high-grade line of talking machines has an opening for a high-class man to assume charge of their sales. Applicant must be well experienced in the trade and must be able to show a record of past accomplishments. Address "Box 785," care The Talking Machine World, 373 Fourth Ave., New York City.

**WANTED**—Salesman on commission to sell phonographs. Address The Oscar Onken Co., Cincinnati, O.

**WANTED**—Salesmen in each State to sell popular-priced phonographs as side line, on commission basis only. See our page advertisement in this issue. Address Charmaphone Co., 39 West 32nd St., New York City.

**WANTED**—An executive, also a sales manager by a well-known New York distributor. One who is willing to take an interest in the firm preferred. An excellent opportunity for the right man. Box 788, care The Talking Machine World, 373 Fourth Ave., New York City.

### RETAIL DEPARTMENT MANAGERS

#### WANTED

Manufacturers of one of the world's leading lines can place a number of men as department managers with its dealers.

These men must have a good knowledge of retail merchandising as applied to phonographs and records.

They must know how to make ordinary motor and cabinet repairs.

Positions open are in cities of medium size. Married men wishing to locate permanently will consider this an unusual opportunity, as a minimum income of \$3,000 per annum is practically assured, with conditions such that considerably more may be earned.

When applying give following information: Experience, age, nationality, married or single.

Address "Excellent Future," care Talking Machine World, 373 Fourth Avenue, New York City.

*The Tone that keeps Milwaukee famous! Grace, beauty, elegance, wonderful tone, acoustic and mechanical perfection. BUILD PHONOGRAPHS! Sell Outingphones! Plans Knockdowns, guaranteed accessories. Records. Catalog 10c stamps. Riviera, Inc., Dealers, Milwaukee.*

#### WANTED

We want to hear from firms who are in a position to make a large quantity of phonograph cabinet legs with simple carving at top and bottom. Address Box 784, care The Talking Machine World, 373 Fourth Ave., New York City.

The Woolworth Phonograph and Record Exchange, wholesale and retail, is for sale on account of old age. Stands full investigation. A gold mine all year round. Stock \$16,000; Good Will, \$5,000. Write for appointment, 1065 Second Ave. (56th St.) afternoon and evening 1 to 11 P. M. B. Bearwald.

#### RECORD EXPERIENCE

I am prepared to supply assistance to any company desiring knowledge of the latest methods of recording matrix making or pressing. Have had years of experience. Would make masters under contract in my own laboratory. Address Box 787, care The Talking Machine World, 373 Fourth Ave., New York City.

**POSITION WANTED**—Salesman 28, have covered Pennsylvania, Ohio, Philadelphia, Baltimore and Washington. For five years was with well-known record company and understand all branches of the business. Salary or drawing account. Excellent reference. Address Box 789, care The Talking Machine World, 373 Fourth Ave., New York City.

**POSITION WANTED**—Managership of retail store by experienced salesman-manager, with ten years' experience in field, six years' retail managing experience. Desires opening because of retirement from business of previous connection. Pleasing personality. Best references can be furnished. Address Box 780, care The Talking Machine World, 373 Fourth Ave., New York City.

**MAN** with twelve years' talking machine selling experience would like to connect with some wholesale house as traveling salesman or department manager. I know Victor, Columbia, Sonora, Brunswick and Vocalion lines. Address Box 781, care The Talking Machine World, 373 Fourth Ave., New York City.

### CABINETS

Genuine mahogany 7/8" sides and back 5 ply 50"x23"x25", \$46. Prompt deliveries. 45"x19"x35". Send for sample. Address The Meritone Phonograph Co., Newark, N. J.

### TURN-TABLE CASTINGS

Have on hand about 4,000 10" iron turntable castings. 30c each, F.O.B., New York. Address Foster-Merriam & Co., 225 Canal St., New York City.

### WANTED

Victor, Columbia, Gennett and Emerson records. We will buy from 100 to 10,000 for spot cash. Let us know what you have. Address Candioto Piano Co., 155 So. Limestone St., Lexington, Ky.

## Main Springs

2	in. x 0.22 x 16 ft., Meisselbach	.....	Each	\$1.25
1 1/4	in. x 0.22 x 17 ft. reg. Victor	.....	Each	0.75
1 1/4	in. x 0.22 x 17 ft., Victor new style	.....	Each	0.75
1	in. x 0.28 x 10 ft., for Columbia	.....	Each	0.50
1	in. x 0.20 x 13 ft., Victor	.....	Each	0.50
1	in. x 0.20 x 13 ft., Victor new style	.....	Each	0.50
1	in. x 0.23 x 10 ft., for Blick mtr.	.....	Each	0.38
3/4	in. x 0.23 x 10 ft., oval hole	.....	Each	0.35
5/8	in. x 0.22 x 8 ft., for Swiss mtr.	.....	Each	0.27
3/8	in. x 0.25 x 11 ft., for Edison	.....	Each	0.27

### MICA DIAPHRAGMS

1	23/32 in. Victor Ex. Box, first grade	.....	Each	0.15
1	1/2 in., new Victor No. 2, very best	.....	Each	0.18
1	31/32 in., for Sonora	.....	Each	0.20
2	3/16 in., for Columbia No. 6	.....	Each	0.25
2	9/16 in., for Pathe or Brunswick	.....	Each	0.45

### SAPPHIRES

Pathe, very best loud tone, genuine	.....	Each	0.27
Pathe, soft tone	.....	Each	0.27
Edison, very best, medium tone	.....	Each	0.27
Edison, very best, loud tone	.....	Each	0.27
Edison, genuine diamond	.....	Each	2.50

### STEEL NEEDLES

AMERICAN MADE extra loud, loud, medium and soft needles	.....	Per 1,000	0.60
---	-------	-----------	------

### ATTACHMENTS

Kent attachments for Victor Arm	.....	Each	0.25
Kent attachments for Columbia Arm	.....	Each	0.25
Edison attachments with C box	.....	Each	2.50
Kent attachments for Edison	.....	Each	1.60

### MOTORS

Distributors for Helneman and Meisselbach Motors. Best Prices. Immediate Deliveries.

### STONE ARMS

No. K with sound box	.....	Each	\$3.25
No. E with sound box, very loud and clear	.....	Each	\$6.00

### LID SUPPORTS

Automatic	.....	Each	0.30
-----------	-------	------	------

### NEEDLE CUPS

Highly nickel plated	.....	Per 100	\$2.00
Covers for cups	.....	Per 100	\$1.00

### REPAIR PARTS

Columbia driving shaft, No. 11778	.....	Each	0.70
Columbia bevel pinion, No. 12333	.....	Each	0.90
Columbia cranks	.....	Each	0.45
Columbia governor weights	.....	Each	0.08
Columbia governor shaft, No. 3004	.....	Each	0.40
Columbia gov'r hearing, No. 11923	.....	Each	0.25
Columbia governor springs	.....	Per 100	1.00
Columbia governor screws	.....	Each	0.01
Columbia barrel screws, No. 2621	.....	Per 100	1.00
Columbia so'dbox thumb screws	.....	Per 100	1.50
Victor cranks, short or long	.....	Each	0.45
Victor soundbox thumb screws	.....	Per 100	1.00
Victor Stylus har (needle arm)	.....	Each	0.35
Victor governor springs	.....	Per 100	1.00
Victor governor screws	.....	Each	0.01
Turn-table felts, 10 in., round	.....	Each	0.15
Turn-table felts, 12 in., round	.....	Each	0.20
Victor governor balls, new style	.....	Each	0.10

## FAVORITE MFG. CO.

1506 DeKalb Ave., Brooklyn, N. Y.



**STATE REPRESENTATIVES WANTED**

in every State in the Union except Ohio, New York and Western Pa. This is a big money proposition and only men who can show a successful record will be considered. Kindly answer the following questions in your application. All replies will be treated as strictly confidential.

1. Territory desired.
2. What territory have you been covering?
3. Experience, if any, in the talking machine business. (Experience is desirable, but not essential.)
4. Give summary of your experience for the past five years.
5. Are you employed at present?
6. By whom?
7. In what capacity?
8. Why do you wish to make a change?
9. Have you sufficient financial strength to employ sub-salesmen for the purpose of thoroughly covering your territory?
10. Give reference.

**Excel Cabinet Company**

136 West 23rd St. New York City

**EXCEPTIONAL OFFER OF MAGNEDO NEEDLES**

Carton of 60 bags. Regular price, \$3.90. Special, \$3.30, in lots of 6 cartons; \$3.10 in lots of 25 cartons. Also a limited quantity of Repeat-O-Graphs at a real bargain price. Send for catalog. Address Phonograph Supply Co. of New England, Court Square, Boston, Mass.

**WANTED**

Victor and Columbia records. Job lots any quantity. *Spot cash* paid for them. Address

DENINGER CYCLE CO.,  
Rochester, N. Y.

**FOR SALE**

Well established music store in good territory in the Middle West, handling old established lines of pianos, phonographs and small instruments, population over 7,000, can do from \$3,000 to \$5,000 a month. Stock including fixtures and delivery car in all invoice from \$7,000 to \$8,000. Reason for selling, other business demanding all of my attention. Full particulars to interested party. Address Box 765, care The Talking Machine World, 373 Fourth Ave., New York City.

**FOR SALE**

Phonograph records, Victor, Columbia, Emerson (brand new). A very fine assortment of vocal and instrumental selections. Particulars given upon request.

I. DECKINGER  
3064 Albany-Crescent Ave.  
New York, N. Y.

**WANTED**

100,000 Edison Blue Amberol records, also Victor, Columbia, Edison Disc, Emerson, Pathé, or any make, new or second hand. Give details. Pay cash. Address Benjamin Weil, 20 South Second St., Philadelphia, Pa.

**Record Expert Wanted**

The president of a very large Japanese talking machine concern is desirous of securing the services of a first-class man for making vocal records. He wants none of mediocre ability, only the best. To the right man who can come to the Orient, his company can pay a very good salary and, of course, his traveling expenses. If you are a recording expert, it will pay you to consider this very carefully, as the domestic and export possibilities which lie before this Japanese manufacturer are decidedly great. Address "Record Manufacturer," c/o The Talking Machine World, 373 Fourth Ave., New York City.

**PHONOGRAPH CABINETS**

We own and operate three factories producing phonographs and cabinets. For shipment this year we will accept contracts for a limited number of cabinets. Our designs with modifications for adaption to your trade. We will make prompt shipments. Address E. H. Stafford Mfg. Co., McClurg Building, Chicago, Ill.

**WANTED**

Victor and Columbia records. Job lots any quantity. *Spot cash* paid for them. Address

STANDARD PHONOGRAPH HOUSE  
1414 Franklin Ave. St. Louis, Mo.

**WANTED**

Victor and Columbia records. Job lots, any quantity. *Spot cash* paid for them. Address Lemke Music Co., 204 South Fourth St., Minneapolis, Minn.

**VICTOR AGENCY WANTED**

By large furniture store in town of 5,000. Address Box 782, care The Talking Machine World, 373 Fourth Ave., New York City.

**VICTOR AUXETOPHONE WANTED**

In reply give full particulars as to condition and price wanted. Address Box 783, care The Talking Machine World, 373 Fourth Ave., New York City.

**CABINETS**

At Prices That Are Right

STYLE 200  
48x21x23

Our best seller. Finished in mahogany, walnut or oak, ready for installation of motor and tone arm.

Prompt deliveries. Send \$37.50 for sample.



**BADGER STATE CABINET CO.**  
MILWAUKEE, WIS.

**MANUFACTURERS' AGENTS**

having extensive acquaintance with hardware, jobbers, furniture and department stores in territory from Denver West, are interested in becoming exclusive agents for one or two reputable manufacturers appealing to this trade. Address Dobb & Dunjill, Manufacturers' Representatives, California-Pacific Bldg., San Francisco, Cal.

Wanted several good salesmen to carry our high grade line of Stein-Burn machines for the following territory: Metropolitan District, New York State, Virginia, North Carolina and New England. Liberal commissions and advances on sales. Only first class men need apply. A. M. Druckman, 140 West 23rd St., New York City.

**WAX BLANKS**

I am prepared to accept orders for a limited quantity of master wax on monthly delivery basis. Address Box 786, care The Talking Machine World, 373 Fourth Ave., New York City.

We manufacture all kinds of phonograph material, such as legs, grills, mouldings, etc. Let us know your requirements. Address Everett Hunter Mfg. Co., McHenry, Ill.

**FOR QUICK SALE AT A SACRIFICE**

*A Positive Saving of 50% Guaranteed*

500 Phonographs Complete

In Genuine Mahogany and Oak  
STAND 52 Inches High

Equipped with Heineman No. 77 Motors and No. 11 Tone Arms. Prices and illustrations on application.

Write or Wire

**The H. Victor Phonograph Co.**  
6129 Page Avenue, St. Louis Mo.





# EUROPEAN HEADQUARTERS

2 GRESHAM BLDG., BASINGHALL ST., E.C. LONDON

W. LIONEL STURDY, MANAGER

Indications That Business Lull Is Coming in British Gramophone Trade, But Interests Are Working to Counteract Depression—Good Work of Federated Board of Music—New Concern to Manufacture Clocks and Gramophones—Retail Gramophone Dealers' Association Formed—General Trade Conventions to Be Held at Scarborough—What the New Record Lists Have to Offer—Trade Well Represented at Recent Expositions—German Manufacturers Increase Prices—Other News

LONDON, ENGLAND, April 2.—Reports to hand from various centers of gramophone trade activity rather indicate that the quiet period is approaching. The real live dealer is, of course, able to make a respectable turnover, and it is therefore not surprising to find upon analyzing the situation that the loudest complaints of dull trade emanate from quarters not overblessed with imaginative, pushful retailers. People used to buy gramophones and records. Most dealers now find, especially at this time of year, that their goods need to be sold if business is to be maintained. Trade stimulus depends a good deal upon the men who by reason of their position are in direct touch with the public. Manufacturers and wholesalers may advertise, and do, but half the value of their expenditures may easily be lost unless dealers energetically cooperate. The big companies are specializing publicity on dance records at the moment, and presently the portable outdoor gramophone will come into prominence. Intelligent retailers follow the theme of these advertisements by suitable window displays, local publicity and spe-

cial communications to their known clientele. Intelligence is an expanding force in British gramophone retail circles. Thus is the present trade slump not so bad as it might be. Business generally is quiet and labor unrest cannot be ruled out as a factor responsible in part for the present trade depression. Let us recognize that, broadly, the gramophone business has its "seasons"; that we are out of that season now, and that, economic influences considered, we must therefore appreciate that machines and record sales to-day are not unsatisfactory.

Spring is generally a slack period for everyone concerned in the gramophone business. From July onward certain sections of the trade get busy in preparation for the active Autumn and Winter months when retail sales are at their best. The next few months will be devoted to the sales development of the portable type of instrument. It has immense possibilities. We have only touched the fringe of this class of trade and I believe that a steady effort on the part of dealers will do much the next few months to counterbalance depression in the sale of other models. Manufacturers are to feature portable instruments very strongly during the Summer and dealers should find their business respond accordingly.

#### The Federated Board of Music

The recent movement inaugurated under the title of the Federated Board of Music is bound to exert a beneficial influence on the development of the gramophone trade in this country. Its main object is to create among the masses a higher appreciation of music. One of the directions in which the objects will be attained

is co-operation with municipal and other local bodies throughout the country. It means, of course, much propaganda work of an educational nature, to the furtherance of which an organizing director has already been appointed at a very good salary. He is a man of education, ability and good presence. His recent address to the committee of the board created a most favorable impression and he is generally regarded as the right man for what must be a rather difficult position.

The gramophone industry is probably the largest disseminator of music among the people and it is therefore more closely concerned with the scheme of the Federated Board than any other section of the trade or profession. To promote a healthy love of good music is to promote the sale of gramophones and records. Because, as Sir George Croydon Marks said at the recent association dinner, reported elsewhere, "The employment of mechanical devices (of present-day perfection) was no parody of music." Hence, the extensive love of music developed among the people by the efforts of the Federated Board should result in enormously stimulating the demand for machines and records. Every dealer is closely associated with this enterprising movement—its success means additional sales. That is one reason why the retail trade must co-operate financially and in all other ways energetically.

#### To Exploit Clocks and Gramophones

Under the title of English Clocks & Gramophones, Ltd., has been formed a new company with a capital of £250,000 in £1 shares. Object: To manufacture clocks and gramophones. For



"His Master's Voice"

Copyright

This intensely human picture stands for all that is best in music

—it is the "His Master's Voice" trade-mark, and it brings to you, no matter where you are, the very best music of every kind, sung and played by the world's greatest artists—the greatest singers, pianists, violinists, orchestras and bands—all enshrined in the unequalled "His Master's Voice" records

## 'His Master's Voice'

—the trade-mark that is recognized throughout the world as the

### HALL-MARK OF QUALITY

#### Branches

**DENMARK:** Skandinavisk Grammophon-Aktielselskab, Frihavne, Copenhagen.

**FRANCE:** Cie. Française du Gramophone, 115 Boulevard Richard Lenoir, Place de la République, Paris.

**SPAIN:** Compañia del Gramofono, 56-58 Balmes, Barcelona.

**SWEDEN:** Skandinaviska Grammophon-Aktiebolaget, Drottning Gatan No. 47, Stockholm.

**RUSSIA:** The Gramophone Co., Ltd., 45, Nevsky Prospect, Petrograd (Petersburg); No. 1 Solyanka, Solyanoi Dvor, Moscow; 9, Golovinsky Prospect, Tiflis; Nowy-Swiat 30, Warsaw; 11 Michailovskaya Ulitsa, Baku.

**INDIA:** The Gramophone Co., Ltd., 139, Balhaghatta Road, Calcutta; 7, Bell Lane, Fort, Bombay.

#### Great Britain:

## The Gramophone Company, Ltd.

HAYES - MIDDLESEX - ENGLAND

#### Agencies

**AUSTRALIA:** S. Hoffnung & Co., Ltd., Sole Concessionaries of The Gramophone Company, Limited, 163, Pitt Street, Sydney.

**NEW ZEALAND:** Gramophonium, Ltd., 118-120 Victoria Street, Wellington.

**SOUTH AFRICA:** Darter & Sons, Post Box 174, Capetown; Mackay Bros., Post Box 251, Johannesburg; Mackay Bros. & McMahon, Post Box 419, Durban; Ivan H. Haarbuerger, Post Box 105, Bloemfontein; Franz Moeller, Post Box 108, East London; B. J. Ewins & Co., Post Box 86, Queenstown; Handel House, Kimberley; Laurence & Cope, Post Box 132, Bulawayo; The Argus Co., Salisbury.

**EAST AFRICA:** Bayley & Co., Lourenso Marques.

**HOLLAND:** American Import Co., 22a, Amsterd Veerkade, The Hague.

**ITALY:** A. Bossi & Co., Via Orefici 2, Milan.

**EGYPT** (Also for the Soudan, Greece and the Ottoman Empire): K. Fr. Vogel, Post Box 414, Alexandria.



**EDISON BELL**



CABLE  
"PHONOKINO,  
LONDON"

**ARE THE GREATEST VALUE FOR MONEY PRODUCED IN GREAT BRITAIN**

TEN INCH

DOUBLE SIDED

NEEDLE CUT

**PLAY ON ALL GRAMOPHONES**

**Catalogue contains 4000 Titles by the Premier Artistes, Instrumentalists, Orchestras and Bands of the British Empire**

DEALERS PREPARED TO DO BUSINESS ARE INVITED TO COMMUNICATE WITH

**Proprietors and Manufacturers, J. E. HOUGH, Ltd., 62 Glengall Road, London, S. E. 15, England**

**FROM OUR LONDON HEADQUARTERS—(Continued from page 236)**

this purpose the company has entered into an agreement to acquire from the Portholme Aircraft Co. its recently erected and equipped factory at Huntingdon, known as the Precision Engineering Works. The inventions, patents, etc., of the Bellaphone Co., Ltd., makers of the Diaphone instruments and sound boxes, pass to the new company. Manufacture at the new works should commence as soon as the company formation arrangements have been settled. We notice that one of the directors is Henry Billingham, managing director of John Brinsmead & Sons, Ltd., the well-known piano makers. The registered office of the company is at Eldon House, Eldon street, London, E. C., 2.

**Meeting of the Federated Board of Music**

Under the chairmanship of Alexander Dow, president of the Federated Board of Music Industries, a general meeting of the various committees was held at the Midland Grand Hotel, London. Among those present were Sir F. Dyson, Sir Harry Foster, G. A. Wales Beard, P. Booth, H. Billingham, Keith Davies, H. J. Fletcher, Dr. A. G. Hill, H. A. Marshall, C. Bruce-Miller, J. A. Murdoch, R. W. Pentland, W. Saville, L. Shenstone, W. Rushworth, Louis Sterling, W. Thomson.

After a favorable report on the financial position of the board was given by the honorary treasurer, A. Dow stated that the finance committee had approved a scheme for the derivation of revenue by means of stamps to be affixed on the instruments or invoices. The stamps will be of the denomination of 2s. 6d. per piano and 3d. per gramophones. The Suppliers' Association scheme, as approved, is at the rate of 1s. 8d. per £100 value of goods. A small contribution will also be made by the Organ Builders' Association. By this means a goodly income is anticipated. The hope was expressed that the Publishers' Association would join up later.

The board are appointing an organizing director and one of the selected candidates, upon being invited to address the meeting, expounded a plan of campaign which demonstrated that he possessed an excellent appreciation of the great possibilities that exist for the British music industries.

**Retail Gramophone Dealers' Association Formed**

The proposal to form a Gramophone Retail Dealers' Association, first put forward at a dinner given to M. G. Ricketts, has now taken definite shape. E. Rasin Jones, of Manchester, was proposed as first president; J. H. Riley, of Birmingham, as vice-president. The following as committee: E. J. Marshall, of Sir Herbert Marshall & Sons, of Regent street; E. J. Price, of Messrs. Scotchers, of Birmingham; Gerald Forty, of Messrs. Dale, Forty & Co., of Chesham; M. H. Baden, of Messrs. H. Evans & Co., of Sheatham; F. T. Stokes, of Messrs. Keith, Prowse & Co., of London; and W. S. N. Shand, of Rockley's Musical Service, Ltd., agreed to act as secretary pro tem.

Subsequently a meeting was held at 233 Regent street, London, on March 8, at which the above firms were represented. The urgent necessity of joining an association of retail gramophone dealers was unanimously agreed upon. The principal advantages and objects of the association are:

- (1) To organize the retail trade and appoint representatives to interview manufacturers and factors from time to time in order to secure all possible benefits for the retail trade.
- (2) To discuss any question arising in respect to wages, hours and conditions of employes.
- (3) To confer with the Board of Trade relative to tariffs, imports and export conditions, transit facilities, etc.
- (4) To consider suggestions for advertising schemes that would benefit the retail trade.
- (5) To promote, protect and secure the in-

terests of retail dealers in gramophones, records and accessories.

(6) To consider, and, if thought advisable, assist members with legal advice and assistance on any matters which members might not be in a position to carry through themselves.

(7) To arrange for addresses to be given to members from time to time in various provincial centers by prominent business men on matters likely to be helpful to members in the conduct and expansion of their businesses.

(8) To arrange propaganda for the further use of gramophones in public institutions.

(9) For the further establishment of a grievance committee, who shall always be in a position to act.

The experience of the last few years must have demonstrated to all observers the vital importance of unity and it is strongly felt that retail gramophone dealers in Great Britain, numbering upwards of 8,000, would be in a very much stronger position if banded together in an association of this kind.

**First Annual Dinner of the Association**

Alike in the social as in the commercial sense, the first annual dinner of the Association of Gramophone and Musical Instrument Manufacturers and Wholesale Dealers which took place on March 8 at the Restaurant Frascati, London, must be regarded as of the greatest importance. The speeches were of high order, of real knowledgeable intent, and reflected a note of optimism which bodes well for the further expansion of this really trade-useful association.

About 150 manufacturers, wholesalers, dealers and other members of the trade were present, the more prominent being: Sir G. Croydon Marks, C. B. E., M. P.; Herbert Marshall; Alex. Dow, president of the Federated Board; Sir Harry Foster, president Pianoforte Manufacturers' Association; A. H. Hughes, president Piano-

(Continued on page 238)

**PEROPHONE—PERFECTION—PRODUCTS**

**PEROPHONES  
SELL . . .  
and carry with  
them a reputa-  
tion of sound  
business for the  
Agent. . . .**

**T**HE whole output of **Perophone Machines** is practically booked up month by month.

Watch the New Models we are introducing to the gramophone public during the present season. They will be found to be incomparable for quality, value, beautiful design and finish.

**PEROPHONE LTD. (Lockwood's Branch) 76 & 78 City Road,**

**Cable Address—Perowood, London. Immediate Shipments. LONDON, E. C., ENGLAND.**

**A. B. C. Codes.**



FROM OUR LONDON HEADQUARTERS—(Continued from page 237)

forte Supplies Association; A. Bosworth, late president of the Music Publishers' Association; G. A. Wales Beard, secretary of the Organ Builders' Association; Dr. C. Maynard Owen; Rasin Jones, president of the Gramophone Dealers' Association; Nelson Samuel; M. E. Ricketts; A. E. Cubinson, association's solicitor, and Howard Button, association's accountant.

The dinner menu was generally conceded to be one of the best experienced at such functions and all seemed heartily to appreciate the Frascati service. This over, the toastmaster got busy. H. M. the King. Then the toast of the Association, coupled with the president, proposed by Herbert Marshall; response by Frank Samuel, the president, in the chair. Mr. Marshall reminded his audience that though they could claim the honor of having the youngest president of any musical association, Mr. Samuel was a man of far-seeing, good, sound judgment and real ability. The very valuable work of C. E. Timms, the secretary of the association, was mentioned, especially in regard to the useful information imparted to members through the monthly news letter.

Upon rising to respond the president was received with cheers, very hearty and prolonged. He made a fine speech, brimful of interesting facts. They could look back, said Mr. Samuel, with much satisfaction to the work accomplished. The membership of the Association now totaled 122, composed of forty-five gramophone, parts and accessories manufacturers, thirty-two manufacturers of other classes of musical instruments, the balance being made up of wholesale dealers. The proportion of manufacturers to dealers, he thought, was satisfactory. The spirit of co-operation was prevalent—that aspect was reflected by the gathering together that night of all shades of opinions and interests. Every attention would be given

to the separate branches; their interests being dealt with in sections. In future news letters issued by the Association, the Board of Trade export figures of musical instruments would be available. The president next acknowledged the valuable assistance of Mr. Timms—to him their thanks were due—he had been largely instrumental in making the Association what it is.

Here, the late (and first) president of the Association, Mr. Ricketts was asked to accept a nice gold wrist watch, suitably inscribed, as a small recognition of what Mr. Samuel described as his inestimable service to the trade. Though very easy to forget, we cannot overlook it, said the president. (Cheers.)

Next on the toast list was the Federated Board of Music Industries, coupled with Alexander Dow, proposed by Sir George Croydon Marks, C. B. E., M. P. Sir George is a parliamentarian of no mean repute. He at one time represented the legal interests of Thomas A. Edison on this side. Now, even more closely associated with our industry, it was no wonder that his audience anticipated a speech of some importance. They were not disappointed. In the course of a most rousing speech, Sir George pleaded the cause of British music. Music, said he, was the expression of the feeling of the people. The Federated Board combined all the associations, embraced all instruments. The gathering that night was a kind of a rally. The employment of the mechanical devices of today was no parody of music. Their one supreme idea was the Federated Board of Music, and they were only concerned with co-operation to make more extensive the love of music in their country. (Applause.)

To this, of course, Alexander Dow was down to respond. He received an ovation upon rising, for it is generally appreciated that the whole conception of the Federated Board idea and

its success is due to his zest and ability. Mr. Dow said that the Gramophone Association was part and parcel of the Federated Board; it subscribed some £2,500 towards the initial expenses of the board, and had promised a further contribution of £2,000 per annum. The Federated Board was a big task to carry out, and it was difficult to appreciate the magnitude of the work involved—to get into good working order. Propaganda was of the utmost importance. Their influence with the "authorities" must be such that when the Federated Board wanted a thing done, they had only to ask to get it done. Referring to the great value of the Federated Board and its work in behalf of British music industries, Mr. Dow emphasized the necessity for continuous support from all sections of the trade.

There was only one association—the Music Publishers—outside the scope of their union, but he was glad to say that the words of Sir George Croydon Marks that evening had been instrumental in carrying conviction to the late president of the Music Publishers' Association, A. Bosworth, who would doubtless throw his weight successfully into the councils of that association. Winding up with a reference to the high motive of the board, and to his audience to consider themselves missionaries for the development and advancement of music, Mr. Dow sat down to the accompaniment of much congratulatory applause—an appreciation of his fine work for the association.

The next toast was the Allied Association of Music Industries, proposed by M. E. Ricketts, who here took advantage of the opportunity of returning thanks in a few graceful sentences for their very acceptable gift to him that evening. Continuing, Mr. Ricketts referred to the claim made regarding Frank Samuel, and humorously observed that he (Mr. R.) claimed to represent

# GRAMOPHONES

Complete—Fittings—Sundries—Repair  
Parts—Needles

*Special Lines and Quotations for Export Trade*

## THE BRITISH POLYPHON CO.

Glasgow, Scotland  
27 Jamaica St.

1, 2 and 3 NEWMAN STREET  
LONDON, W. 1, ENGLAND





# YE "POPULAR" RECORDS

Double-Sided  
Superb Needle Cut  
"Lateral"

LONDON'S LEADING VALUE!!!

"OUR POINTS"  
SET OUT BELOW

Have Attracted Keen Overseas Houses

from SCANDINAVIA to PATAGONIA  
AND THE PRINCIPAL  
EAST and WEST MARKETS of the WORLD

**IMPORTANT** We can give  
customers their  
own design Labels for LARGE Parcels.

**REMEMBER** You Can Have **CLOSE QUOTATIONS**

For 5,000 Lots and up "Your Selection" or a Sample 1,000,  
made up with "One Example" of Every Catalogued Pairing.

**Address: SOUND RECORDING CO., Ltd.** CABLES "Grammavox"  
EXPORT DEPT., 18-19 Swallow Street London  
Piccadilly, London, England "QUOTATIONS CABLED FREE"

**POINTS**

- ➔ Repertoire Approx 2,000 Titles—Covering
- ➔ Superb Selection, Bands and Orchestrals
- ➔ Lightning Shipments
- ➔ Packing by Experts
- ➔ Rock Quotations "Always"
- ➔ F. O. B. London
- ➔ We attend to all Insurances "if Requested" to Buyers A/c
- ➔ Our Shipping Services, this Side FREE

FROM OUR LONDON HEADQUARTERS—(Continued from page 238)

the youngest Association in the music trade—British Associated Pianomakers. Briefly covering ground of the many difficulties dealt with by the Gramophone Association during the war, he thought that the foundation was now laid to erect an edifice stronger, he believed, than had ever been erected before. (Cheers.) In response, Sir Harry Foster, president of the Pianoforte Manufacturers' Association, made a speech of considerable interest to those present. He hoped the Federated Board would eventually embrace every branch of the trade, notably the Music Publishers' Association, and he was certain of the long continued prosperity of the Gramophone Association.

H. G. Cullum was next called upon to propose the visitors. He read letters of regret from those unavoidably absent, notably Sir Frederick Dyson, J. P. (president, Music Trades Association), and one from Alfred Clarke (managing director of the Gramophone Co., Ltd.), who had unfortunately met with a motor accident. We are glad to learn that it is not serious. G. A. Wales Beard and Mr. Bosworth made suitable response. In the course of his remarks Mr. Bosworth mentioned that gramophone record royalties to publishers and composers amounted to something like £100,000!

The toast of the president was proposed in felicitous terms by W. Manson, the vice-president, to which Frank Samuel responded.

During the evening selections were played by Van Zier's orchestra, and songs contributed by leading vocalists.

**Visits General Phonograph Corp.**

Reports received from A. J. Balcombe at the London branch of the General Phonograph Corp. indicate that his recent trip to the company's New York headquarters has resulted in the consummation of satisfactory business arrangements for increased deliveries of the "Motor of Quality." It was thought at one time

that the adverse exchange rates between the two countries would seriously jeopardize future consignments. Mr. Balcombe's trip was largely in connection with this matter, and it will be very satisfactory to the trade here that there is now little possibility of motor consignments from your side failing.

At the time of writing Mr. Balcombe is aboard the S. S. Baltic in mid-Atlantic on the homeward journey. His itinerary was somewhat varied, for I learn upon inquiry of his son, who makes a good second-in-charge here, that Mr. Balcombe visited some of the different factories and branches of the General Phonograph Corp., notably at Elyria, Chicago, and Kitchener, Ontario.

The company have handled a large trade for the "Motor of Quality" in Great Britain and from all I hear, sales will move even more quickly upon Mr. Balcombe's return.

**British Trade Press to Insert German Ads**

At a recent gathering of the British Association of Trade and Technical Journals, Sir Auckland Geddes, president of the Board of Trade, was asked for advice on the question of acceptance of advertisements from late enemy firms. In reply he said that many people might say "no," but he was not afraid to say "yes." That would annoy a few people who could not see beyond their noses, and those who wished never again to have anything to do with Germany. The latter looked at the matter purely from a sentimental point of view, but he took the business point of view.

Notwithstanding, British trade journals generally favor the protection of British manufacturers by excluding advertisements from late enemy firms, though, be it noted that some of the great dailies are not so particular.

**Music Convention at Scarborough**

The annual Music Trades Convention will this year take place at the coast town of Scar-

borough, from June 9 to 14 inclusive. Detailed arrangements as to trade discussions, subjects, and papers, also as to the social side, are now in course of preparation. It is known that the mayor and corporation of Scarborough will hold a reception at the Town Hall, and the Federated Board of Music are giving a banquet. A particularly good attendance of traders from all parts of the country is anticipated and arrangements will be made accordingly.

**Ebonites, Ltd., Wound Up**

Announcement has been made in the press calling a meeting of the creditors of the above company. The liquidator is Edward Moore, 3 Crosby Square, London, E. C.

**Amberols in Australasia**

Edison phonographs and Blue Amberol records are apparently in considerable favor throughout Australia and New Zealand. A copy of the Phonogram—chattily written-up and itemizing quite a big list of Amberols—has reached me from the Sydney branch of Thomas A. Edison, Ltd.

**Where Do the Flies Go in Winter Time?**

The above is the title of a song which firstly came into vogue at the Dick Whittington panto and subsequently in the music halls. If I remember rightly the answer to the question is Xmas puddings. Anyhow, it's one of those silly numbers that sell, and of course has been further popularized on most of the records. The winner record issue is by Ernie Mayne, the original singer, and exclusive to this company. It is coupled with another terror called "Thuttop Your Thuttering, Thammy." The record is a good presentation of these two numbers, and being by Ernie Mayne is in great demand.

**Opera in English on "His Master's Voice"**

The call for opera in English has been heard to an increasing extent of late, and it is a measure of the higher appreciation of good under-

(Continued on page 240)

## The Sound Box That Has Beaten the Band

An All British Production of the Highest Grade; Marketed at Popular Prices

4—Models Only—4

*Export Quotations for Quantities at  
Extraordinarily Low Prices.*

LARGEST OUTPUT IN UNITED KINGDOM



HOME TRADE OUTPUT BOOKED UP FOR SEASON 1919-1920. WILL MAIL SAMPLE SET 4 MODELS B.C.E.F. (one only) TO ANY RECOGNIZED JOBBER ON RECEIPT DRAFT, \$5 (DOLLARS)

Vernon Lockwood  
Manufacturing Co., Ltd.

76-78 CITY ROAD  
LONDON, E. C. I.



**FROM OUR LONDON HEADQUARTERS**  
(Continued from page 239)

standable music on the part of the public that the "His Master's Voice" Company have been encouraged to meet the call by increased production and new issues. A complete list of about one hundred of these records has been issued. It includes excerpts from most of the leading grand operas, all rendered in English by (for the most part) native artists of international renown. Truly a program to conjure with. It should mean, with the wide publicity the company give to it, magnificent sales for the dealers, who are thereby enabled to cater a class of public which hitherto has remained aloof from the gramophone.

**Trade Represented at Two Exhibitions**

During February advantage was taken of two big Fairs—the first, a public one, the Ideal Homes Exhibition at Olympia—the second, the British Industries Fair for the trade only at the Crystal Palace, at both of which some good gramophone booths were in evidence. As stated in my last report, there can be little question that those few musical instrument houses represented at the Ideal Homes reaped good results.

From the trade viewpoint, perhaps, the British Industries Fair, proved the more important. Here exhibitors were brought into personal touch with United Kingdom buyers in plenty, and quite a goodly number from the colonies and oversea markets. Though some firms expressed disappointment at the actual results, I think, on the whole, it may be regarded as an out and out success for most of the exhibitors. The gramophone section was proportionately much larger than any other musical instrument branch. Indeed, the British pianoforte trade was very poorly represented. This, doubtless, will be remedied at the next official Fair. Of the Gramophone displays the highest praise is due. The exhibits comprised extensive ranges of all types of complete gramophones, British-made motors, sound boxes, tone-arms, and other parts and accessories of endless variety.

**Large Music House Enters Gramophone Field**

What with piano manufacturers and now music publishers venturing upon the domain of the talking machine, it looks as though things will go "some" by next season, if not before. The more the merrier; it is good for the whole trade and will help considerably to widen the sales field in this country.

The great music publishing house of Herman Darewski, Ltd., have recently introduced two



**“PERFECT POINTS”**

**BRITAIN'S BEST**  
**Gramophone Needle**  
*(Guaranteed made from High Carbon Steel)*

IS MADE BY  
**W. R. STEEL, of REDDITCH,**  
Head Office and Works—QUEEN ST.

Scientifically pointed, Hardened and Tempered on the latest up-to-date machinery and plant by skilled craftsmen only.

**RESULT:**  
**A FIRST QUALITY NEEDLE far ahead of anything of pre-war quality**  
INQUIRIES SOLICITED  
Special Quotations for Quantities

**Manufacturer of all Kinds of Sewing Needles**

novelties—the "Tonofone" needle, and talking dolls, animals, etc., both of which emanate from the States.

Interviewed by your representative, Herman Darewski expressed the utmost enthusiasm over the utility, and the great sales-possibilities, of the Tonofone needle, which is good for at least fifty playings. It has been taken up with avidity by the trade and, of course, makes a particular appeal to a large circle of gramophonists on the score of quality and elimination of constant needle changing every time a few records are played.

Through the columns of this trade newspaper my readers are doubtless familiar with the pleasing series of talking animals and dolls which so faithfully portray the stories youngsters delight in. This line has caught on here, and big sales have already been registered.

For both these novelties Messrs. Darewski have the sole selling rights for Great Britain.

**Record Musical Art Portrayed by Columbia**

The high standard of Columbia recordings this month is typical of that real musical art which we have come to associate so closely with the record achievements of this house. In every list there is usually something especially good. Recent issues include the great Tom Burke, who, eschewing all traditions, gives himself over to a delightful rendering of "Donna nou vidi mai" from "Manon Lescaut." The present list, too, itemizes first and exclusive records by two artists whose name and work promise to rank

as high in gramophone work in this country as any in their class. One is Toscha Seidel, the Russian boy violinist, described as "the magician of the bow," and the other Rosa Ponselle, the dramatic soprano, who stepped on a stage unknown and left it a few minutes later the leading soprano of the Metropolitan Opera House, New York.

**German Record Prices Increase**

It is well known that gramophone and record production in Germany has suffered more acutely than in other countries from the many trading difficulties incidental to the war. But, according to the Deutsche Instrumentenbau Zeitung, the German manufacturers report that these difficulties are being successfully overcome. There is still a shortage of materials, but supplies are easier. Good allowances offered for the return of old records will, it is thought, help to make good the shortage of shellac. Instrument sales are said to be exceptionally good notwithstanding the fact that prices have increased anything from four to eight hundred per cent. Two or three agents in England have already been fixed up for the sale of German gramophone parts, accessories and records, and I learn that negotiations are proceeding by other German manufacturers for the marketing of their goods here. These negotiations, however, seem to have for their object the keeping alive of communication, for there is little prospect yet awhile of German goods reaching here in bulk. Certainly, little has come through so far.

**Horn, Hornless and Table-Grand**  
**GRAMOPHONES**  
FOR  
**EXPORT**  
Please State Your Requirements  
**REX GRAMOPHONE CO. 2 Elizabeth Place**  
Rivington Street, LONDON, E.C. 2, England  
Cable Address "Lyrecodisc, London"

**AUSTRALIA.**  
Herbert G. Polyblank,  
SYDNEY,  
N.S.W.

**BELGIUM.**  
P. Carton,  
Rue Karel Ooms, 11,  
ANVERS.

**ITALY.**  
G. Menaboni,  
Via S. Sebastiano 2,  
LIVORNO.

**SPAIN.**  
Ernesto Yerdu,  
ALICANTE.

**ENGLAND.**  
A. Waite & Co., Ltd.,  
15-17 Figtree Lane,  
SHEFFIELD.

*Songster*  
**Talking Machine**  
*Needles*

Manufactured by **J. STEAD & CO. LTD.**  
**MANOR WORKS. SHEFFIELD ENGLAND.**





# LATEST PATENTS RELATING TO TALKING MACHINES AND RECORDS

**Phonograph Resonator.** Wm. C. Beckwith, Urbana, Ill. Patent No. 1,328,412.

This invention relates to improvements in phonograph resonators through which reproduced recorded musical and other sound waves are transmitted to an audience. The form, material and construction of one or more of these things have heretofore been productive of unrecorded roaring tones, echoes, scratching and other seriously discordant sounds destructive of the purity and harmony of the recorded sounds and accordingly irritating to the listener.

The prime object of this invention, broadly stated, is to provide a phonograph with a resonator, the form, material and construction of which is such that in operation it produces the best effects obtainable from a combination of the human throat, a violin and the tube of a horn for unrestrictedly delivering to an audience every sound wave reproduced from a record, to the entire exclusion of unrecorded sounds of every kind and character.

A further object of the invention is to provide a phonograph with a resonator, the character and range of the vibrations of which are such that all recorded overtones, however delicate and soft any of them may be, are so perfectly transmitted in their entirety to an audience that it is possible and practical for the ear of the listener to separate at will the reproduced recorded sounds of any individual voice or instrument from a chorus or other ensemble, and follow it as a solo part however loud and heavy may be the sound waves produced by other individual voices and instruments, or both.

In said drawings Figure 1 is a vertical longitudinal section through a resonator in which the invention finds embodiment. Fig. 2 is a top plan view thereof. Fig. 3 is a detail section

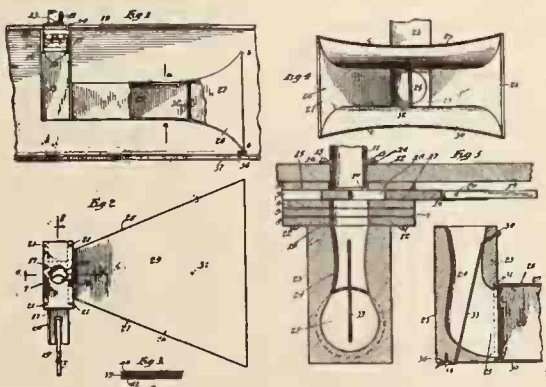

of the laminated materials of which the resonator is partly constructed. Fig. 4 is a front end elevation of the resonator. Fig. 5 is a transverse section taken on the line 5-5 of Fig. 2, and Fig. 6 is a section through the tone separator or throat of the resonator, with a portion of the upper part of the throat broken away.

**Stylus for Sound Reproducing Machines.** Charles H. Gill, Chicago, Ill. Patent No. 1,329,832.

This invention relates to improvements in styli or needles which are used in contact with sound records to convey the recorded vibrations to the sound reproducer for reproduction, and the objects of the improvement are, first, to provide a stylus having a multiplicity of points so that new points may be brought into operative position as required, without the need of inserting a new stylus or needle so frequently; second, to provide supporting and attaching means for said stylus so as to make it available for use on sound-reproducing machines of types now in use; third, to provide means for readily moving a new point into operative position at will and for indicating to the touch and hearing that such new point has been so moved to operative position, and, fourth, to provide means whereby further changes in the operative point

are prevented after all the points on the stylus have been in use.

In the accompanying drawing Figure 1 is an enlarged front elevation showing the complete device assembled; Fig. 2 is an enlarged side elevation of the complete device, with the needle wheel shown in cross section; Fig. 3 is an enlarged side elevation, with the needle wheel

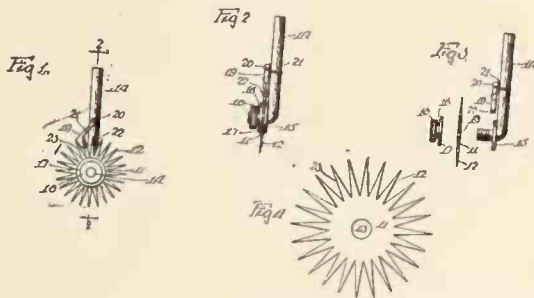

shown in cross section, similar to Fig. 2, but with the needle wheel and clamping nut in removed position, and Fig. 4 is an enlarged front elevation of the needle wheel only.

**Convertible Sound Box for Talking Machines.** Walter W. Jackson, Sewaren, and Christian Paulsen, Rahway, N. J., assignors to the Regina Co., Rahway, N. J. Patent No. 1,329,906.

This invention relates to talking machines and particularly to improvements in the sound box of such instruments.

It is one purpose of this invention to provide a very simple form of sound box capable of being attached to a very simple form of tone arm and requiring but a slight angular movement about an axis perpendicular to the diaphragm in order to adapt it for reproduction with one type of record or the other. No special elbows or connections between sound box and tone arm are required for changing from one record to the other and, in fact, elbows are completely eliminated for either form of record, while the sound box itself, as well as the tone arm to which it attaches, may be of the simplest possible design and construction. The herein described train of mechanism that transmits the vibration from the stylus to the diaphragm may obviously be used in a sound box adapted to play records of one kind only.

This invention will be better understood by referring to the accompanying drawings, in which Figure 1 represents a side elevation of a talking machine of conventional type, having a preferred form of improved sound box attached and arranged to reproduce records of the vertically undulating type, parts of the machine not necessary to an understanding of the invention being cut away; Fig. 2 represents a central vertical section, twice enlarged, taken through

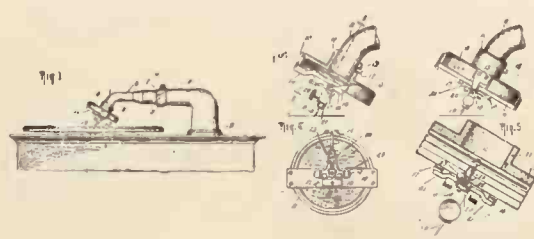

the sound box and end of the tone arm as shown in Fig. 1; Fig. 3 represents a side elevation, on the same scale as Fig. 2, showing the sound box rotated about its central axis through 90°, thus arranged to play records of the laterally undulating type; Fig. 4 is a plan view from the front of the sound box on the same scale as Figs. 2 and 3; and Fig. 5 is a central section, taken on a scale twice that of Figs. 2, 3 and 4, along the line of 5-5 of Fig. 2.

**Tone Modifier for Talking Machines.** Samuel Hough, Atco, N. J. Patent No. 1,330,469.

This invention relates to a new and useful improvement in tone modifiers for talking machines, and has for its object to provide an

exceedingly simple and effective method of controlling the sound waves in their passage from the sound box through the swinging arm to the amplifier of a talking machine, whereby the tone of the reproduced sounds may be modified to make them more acceptable and pleasing to the ear. A further object of the invention is to provide mechanism for modifying the sound in its passage to the amplifier, having sections or wings capable of adjustment in unison.

A further object of the invention is to provide means for actuating sections of the modifier from the outside of the "throat," and so housing such means as to prevent the escape of the sound waves through the openings in the throat, such housing being dustproof for the protection of the mechanism.

In order that those skilled in the art to which this invention appertains may understand how to make and use the same, reference is made to the accompanying drawings:

Figure 1 is a section of the casing of a talking machine, showing the swinging arm amplifier and connections there-between in elevation; Fig. 2 is an enlarged plan view of the improved tone-modifying throat mechanism therefor; Fig. 3 is a side elevation of the throat partly broken

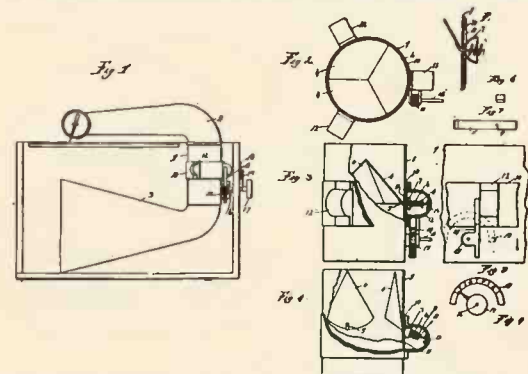

away and sectioned to show the sectional modifier and mechanism for operating the same, the modifier being in its closed position; Fig. 4 is a view similar to Fig. 1, showing the sectional modifier in its open position; Fig. 5 is a still further enlarged detail section, showing one of the sections of the modifier and the manner of connecting it to the throat; Fig. 6 is a detail end view of one of the stems to which the sections of the modifier are secured; Fig. 7 is a plan view of Fig. 6; Fig. 8 is a side elevation of a portion of the throat, showing the rack bar and pinion for operating the modifier, the position of the indicating dial being illustrated in dotted lines, and Fig. 9 is a detail view of a portion of the casing, showing the thumb knob, pointer and dial for setting and indicating the positions of the sections of the modifier.

**Repeating Attachment for Phonographs.** Hubert A. Myers, Toledo, Ohio. Patent No. 1,330,603.

This invention relates to an attachment for phonographs, and particularly to means automatically operable at a predetermined point in an inward movement of the tone arm to return it to initial playing position.

The object of the invention is the provision of a simple and efficient mechanism of the class described, which is automatically operable, at a predetermined point in an inward movement of the associated tone arm, to raise the stylus from engagement with the record, quickly return the arm and attached mechanism to initial playing position and then lower the stylus to engage the record to repeat the playing of the piece, such repeating action being successively continued until the machine runs down or is stopped.

A further object is the provision of means for retarding the downward-swinging or record-engaging movement of the customary stylus of machines of the class described, when ad-

(Continued on page 242)



LATEST PATENTS RELATING TO TALKING MACHINES AND RECORDS—(Continued from page 241)

adjacent to the record, whereby the stylus is caused to lightly engage the record even though the sound box or part by which it is carried may be dropped, thus preventing injury to the record which so frequently occurs by reason of the accidental or careless dropping of the sound box and stylus thereon.

Figure 1 is a plan view of a portion of a phonograph embodying the invention and in playing position. Fig. 2 is an enlarged sectional detail taken on the line 2-2 in Fig. 1 of a portion of the means employed to check the downward or record-engaging movement of the stylus arm. Fig. 3 is an enlarged side elevation of the rotary escapement-controlled member of the attachment, with such member

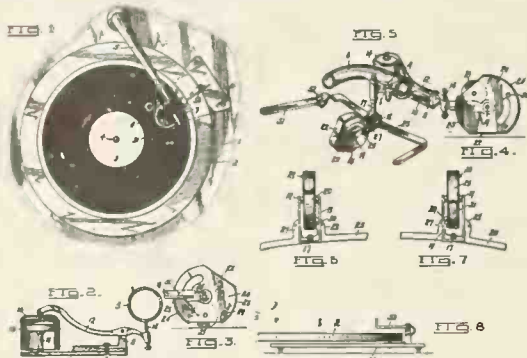

in stylus-raising engagement with a record. Fig. 4 is a similar view, with the member out of engagement with the record, or in playing position. Fig. 5 is a perspective view of the mechanism embodying the invention, with the tone arm to which it is secured partly broken away and with the rotary member in record-engaging or stylus-lifting position. Figs. 6 and 7 are enlarged fragmentary top plan views of the attachment, with parts broken away and with the rotary member in record-engaging position in one and released position in the other, and Fig. 8 is a side elevation of the outer escapement-operating trip means in operative relation to the rotary record-carrying table of the machine.

**Phonograph.** Henry K. Sandell, Chicago, Ill., assignor to Herbert S. Mills, same place. Patent No. 1,331,214.

This invention relates to improvements in phonographs, and more particularly to a motor control mechanism for the same. The principal objects are to provide electrically operated means for moving the reproducer arm to cause a record to be repeated one or more times and means for automatically stopping the motor.

Figure 1 is a plan view of a phonograph constructed in accordance with the invention; Fig. 2 is a side elevation, partly in section, and

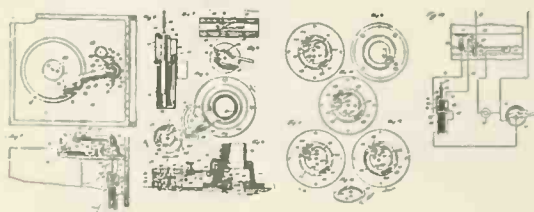

showing the operating solenoid for the reproducer arm; Fig. 3 is an enlarged sectional view through the solenoid; Fig. 4 is an enlarged horizontal section through the base of the reproducer arm, showing in plan view the repeat adjustment mechanism; Fig. 5 is a section on the line 5 of Fig. 4; Fig. 6 is a bottom plan view of the

adjustment dial of the repeat mechanism; Fig. 7 is an enlarged section of the repeat switch taken on the line 7 of Fig. 4; Figs. 8, 10, 11 and 12 are top plan views of the reproducer arm switch; Fig. 9 is a bottom plan view of the same; Fig. 13 is a perspective view of the movable ring of the reproducer arm switch; and Fig. 14 is a diagram of the electrical connections of the phonograph.

**Apparatus for Raising the Tone Arms of Sound Reproducing Devices.** Henry K. Sandell, Chicago, Ill., assignor to Herbert S. Mills, same place. Patent No. 1,331,215.

This invention relates to devices for raising the tone arm of a phonograph or sound reproducing device, and more particularly to a device which operates automatically to raise such a tone arm when the latter reaches a determined point in its movement.

Figure 1 is a side elevation of the tone arm illustrating the relative arrangement of the tone arm and the parts of the lifting device just prior to the operation of the latter. Fig. 2 is a side elevation of a portion of the tone arm, illustrating the relative positions of the tone arm and

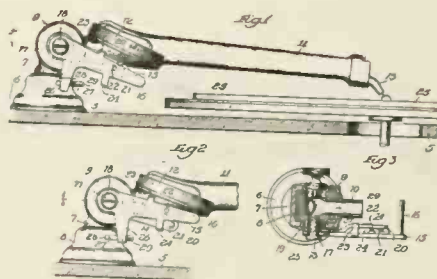

lifting device after the latter has been caused to operate. Fig. 3 is a section through the pivotal portion of the tone arm support, the tone arm proper being removed from the portion of the support to which it is connected in normal use of the device.

**Cover Support.** Burr B. Blood, Chicago, Ill., assignor February 24 of one-half to Geo. Heine-man and one-half to Norman A. Street, same place. Patent No. 1,331,556.

This invention relates more especially to a support for the lid or cover of a phonograph cabinet which is usually pivotally secured or hinged at one side thereof so as to swing vertically, the object of the invention being to provide a construction wherein the supporting position will be automatically assumed when the lid or cover has been raised or lifted into a tilted position.

Figure 1 is a vertical sectional view of a portion of a cover or lid and the upper part of a phonograph cabinet, illustrating the cover support in side elevation; the positioning of the support when the cover or lid is down or closed

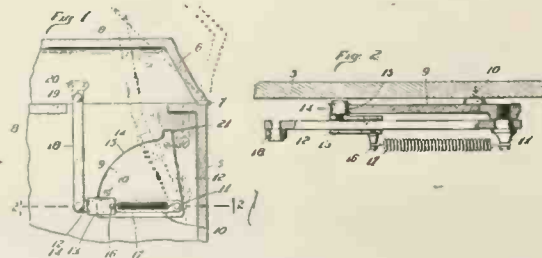

being shown in full lines, while the supporting position of the device, with the cover or lid tilted or raised, is shown in dotted lines. Fig. 2 is a cross sectional view taken on the line 2-2 of Fig. 1, looking in the direction of the arrows.

**Record Repeating Device for Talking Machines.** William H. Fink, Diagonal, Ia. Patent No. 1,331,702.

This invention relates to an improved record repeating device, and one of the objects is to provide an improved mechanism of this kind having tone arm shifting means, and a device actuated by the tone arm for releasing said means, whereby said means may be actuated by a member engaging the center portion of the record, to move said means so that it may lift and return the tone arm to its initial position.

Other objects of the invention are to provide

means for stopping the turntable at the completion of a plurality of repetitions of the record; the provision of means adapted to be adjusted and to be actuated by the tone arm between different predetermined points of movements of the tone arm, whereby records of different diameters with pieces thereon of different lengths may be played and consecutively repeated; means for adjusting the member which engages the turntable so as to permit said member to engage the record at the proper time, in order that it may actuate said tone arm shifting means, whereby said means may return the tone arm to an initial position on the record.

In the drawings Figure 1 is a plan view of a conventional form of cabinet talking machine, showing the record-supporting table, the tone arm with its sound box, and the automatic repeating device as applied. Fig. 2 is an enlarged detail view of the means carried by the repeating device for limiting the repetition of the record. Fig. 3 is an enlarged detail perspective view of the repeating apparatus detached. Fig. 4 is a view in side elevation of said apparatus, showing a revolvable member just in the act of engaging the record on the turntable. Fig. 5 is a view in side elevation of the repeating apparatus, showing the revolvable member as having

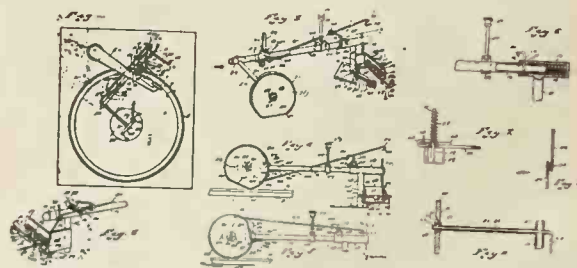

been rotated almost a complete revolution. Fig. 6 is a detail view of a portion of the supporting beam for the revolvable member, showing the support for said beam. Fig. 7 is a detail view of the mounting of the brake-shoe for the turntable. Fig. 8 is a longitudinal sectional view through the tubular beam for the support of the shaft of the revolvable member which engages the record. Fig. 9 shows a detail sectional view of part of the pivot mechanism.

**Phonograph.** Gilbert M. Scherer, New York. Patent No. 1,331,788.

This invention relates in its broader aspect to several features of novelty, one of which comprises mechanism for raising and lowering a phonograph record of the disc type from the rotating disc or table upon which the record is mounted. This mechanism enables the record to be raised for the purpose of removal and also facilitates the replacement or the placing of another record thereon.

Figure 1 is a front view, partly in section, illustrating one application of the invention. Fig. 2 is a side view of the mechanism employed in raising a record from and lowering the same

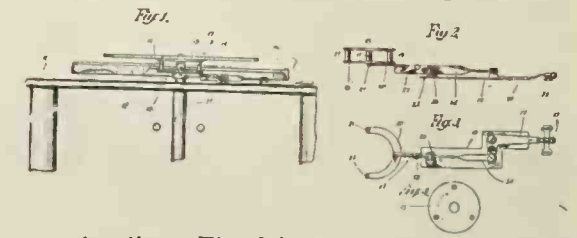

upon the disc. Fig. 3 is a top plan view of the mechanism illustrated in Fig. 2 with the reciprocating support of Fig. 4 omitted therefrom. Fig. 4 is a plan view of the member, for holding the record in elevated position.

The National Association of Music Merchants has decided to ask any religious denomination discountenancing dancing to withdraw its opposition to the custom.

**LESLEY'S PATCHING VARNISH**

Dries in 10 seconds, flows without showing the lap. With it damaged varnish can be repaired invisibly. Price now 1 pint \$1; 1 quart \$1.90. Complete repair outfit, \$3.50. F. O. B. Indianapolis, Ind.

LESLEY'S CHEMICAL COMPANY  
Indianapolis, Indiana

**REPAIRS**

All Makes of Talking Machines  
Repaired Promptly and Efficiently

**ANDREW H. DODIN**

28 Sixth Avenue New York  
TELEPHONE, CHELSEA 8437



# Advance RECORD BULLETINS for May, 1920

## VICTOR TALKING MACHINE CO.

### POPULAR SONGS

- 18656 Daddy, You've Been a Mother to Me. Henry Burr 10
- Just Like the Rose. Charles Harrison
- 18657 How Sorry You'll Be (Wait'll You See) 10
- He Went in Like a Lion and Came Out Like a Lamb. Billy Murray
- 18658 Hand in Hand Again, 10
- Albert Campbell-Henry Burr
- All That I Want Is You. Charles Hart
- 18660 Hiawatha's Melody of Love. Sterling Trio 10
- I'm Always Falling in Love with the Other Fellow's Girl. Elliott Shaw

### DANCE RECORDS

- 18661 Left All Alone Again Blues—Medley Fox-trot, Joseph C. Smith's Orchestra 10
- Whose Baby Are You?—Medley One-step, Joseph C. Smith's Orchestra
- 18662 Karavan—Fox-trot. Joseph C. Smith's Orchestra 10
- When You're Alone—Fox-trot, Paul Biese and His Novelty Orchestra
- 18663 I'll See You in C-U-B-A—Medley Fox-trot, Palace Trio 10

### RED SEAL RECORDS

- The Crocodile—Fox-trot, Wiedoeft-Wadsworth Quartet
- 18655 (1) How Lovely are the Messengers (from "St. Paul") (Mendelssohn) (Violin and Cello duet). (2) See, the Conquering Hero Comes (from "Judas Maccabaeus") (Handel) (Cornet duet) Victor Orchestra 10
- (1) If With all Your Hearts (from "Elijah") (Mendelssohn) (Viola Solo). (2) Pastoral Symphony (from "Messiah") (Handel) (English Horn solo) Victor Orchestra

### GABRIELLA BESANZONI, Contralto—In Italian

- 74613 Carmen—Habanera. Bizet 12
- EMILIO GOGORZA, Baritone—In French
- 64862 Chanson de la Touraine (from "Panurge") (Song of Touraine) Massenet 10
- MISCHA ELMAN, Violinist
- 74607 Song Without Words ("Cradle Song"), Mendelssohn 12

### AMELITA GALLI-CURCI, Soprano

- (Flute obligato by Manuel Berenguer)
- 74608 Lo, Here the Gentle Lark. Shakespeare-Bishop 12
- MABEL GARRISON, Soprano
- 74612 Call Me Thine Own (from "L'Eclair") Halévy 12
- EDWARD JOHNSON, Tenor
- 64864 Sunrise and You. Arthur A. Penn 10
- HANS KINDLER, Violoncellist
- 64861 Fond Recollections. David Popper 10
- PHILADELPHIA ORCHESTRA
- (Leopold Stokowski, Conductor)
- 74609 Symphony in G Minor—Menuetto. Mozart 12
- REINALD WERRENATH, Baritone
- 64863 Duna. Pickthall-McGill 10

## COLUMBIA GRAPHOPHONE CO.

- 49735 La Gioconda-Suicidial In Questi Fieri Momenti (Suicide, My One Resource), Rosa Ponselle 12
- 49612 Barbieri Di Siviglia—Dunque IO Son (What! I?) Barrientos and Stracciari 12
- 49694 'Cause of You. Riccardo Stracciari 12
- 78929 I'd Build a World in the Heart of a Rose, Chas. Hackett 10
- A2889 Golden Crown (A Negro Spiritual), Oscar Seagle 10
- Standin' In De Need o' Prayer (A Negro Spiritual) Oscar Seagle 10
- A2282 Serenade—Violin Solo. Eddie Brown 10
- The Old Refrain—Violin Solo. Eddie Brown 10
- A2886 Sunrise and You—Tenor Solo. George Meader 10
- I'll Think of You When Evening Shadows Fall—Tenor Solo. George Meader 10

### NOVELTY RECORD

- E4520 Fast Polka, Royal Serbian Tambouritzza Orchestra 10
- Grandmother's Waltz, Royal Serbian Tambouritzza Orchestra 10
- A2891 First Waltz—Accordion Duet, Marconi Brothers 10
- Selections From "Faust"—Accordion Duet, Marconi Brothers 10
- A2890 Uncle Zed and His Fiddle—Descriptive Monologue. Rendered by Chas. Ross Taggart 10
- Uncle Zed Buys a Graphophone—Descriptive Monologue. Rendered by Chas. Ross Taggart 10
- A2881 My Mother's Songs—Tenor Solo, William McEwan 10
- One By One We're Passing Over—Tenor Solo, William McEwan 10

### POPULAR HITS

- A2892 Christ in Flanders. Chas. Harrison 10
- In Flanders Fields. Chas. Harrison 10
- A2888 Goodnight Angelina. Peerless Quartet 10
- We Must Have a Song to Remember, Peerless Quartet 10
- A2894 When My Baby Smiles. Henry Burr 10
- Daddy, You've Been a Mother to Me, Lewis James 10
- A2893 Beautiful Hawaiian Love. Campbell and Burr 10
- Hawaiian Hours With You. Campbell and Burr 10
- A2879 Ah! There. (Flirtation Fox-trot), Columbia Orchestra 10
- Just Another Kiss. Waltz. Saxophone, Banjo and Piano. Intro. Valse Inspiration, Paul Biese Trio 10
- A2895 Venetian Moon. Fox-trot. Intro. In Your Arms. Kentucky Serenaders 10
- Bo-La-Bo. Egyptian Fox-trot, Ted Lewis Jazz Band 10
- A6144 If You Could Care. From "As You Were." Medley Waltz. Intro. Hand in Hand Again. Incidental Chorus by Henry Burr. Prince's Orchestra 12
- On Miami Shore. Medley Waltz. Intro. Waltz of Mine. Prince's Dance Orchestra 12
- A2884 Swanee. Al Jolson, Comedian 10
- My Gal. Frank Crumit, Tenor 10
- A2877 I'm Sorry I Ain't Got It You Could Have It If I Had It Blues. Bert Williams, Comedian 10
- Checkers (It's Your Move Now), Bert Williams, Comedian 10
- A2885 Peggy. Chas. Harrison, Tenor 10
- Say It With Flowers. Chas. Harrison, Tenor 10

- A6143 La Boheme Selections. (Part 1) Metropolitan Opera House Orchestra 12
- La Boheme Selections. (Part 2) Metropolitan Opera House Orchestra 12
- A2876 Buddha-Dardanella. Fox-trot, Columbia Saxophone Sextet 10
- Limehouse Nights. One-step. Intro. Poppyland from "Midnight Whirl." Columbia Saxophone Sextet 10
- A2880 Dancing Honeymoon. Fox-trot, Art Hickman's Orchestra 10
- Fee Fi Fo Fum. One-step. Art Hickman's Orchestra 10
- A2883 Afghanistan. Fox-trot, Prince's Dance Orchestra 10
- Mohammed. Fox-trot. Prince's Dance Orchestra 10

### Special May Mid-Month List

- A2898 That Wonderful Kid From Madrid, Al Jolson, Comedian 10
- I'll See You in C-U-B-A. Jack Kaufman 10
- A2909 Lazy Mississippi—Tenor duet. Campbell-Burr 10
- Rose of Virginia—Tenor solo. Henry Burr 10
- A2907 Abe Kabibble at the Ball Game (Abe the Agent Series)—Recitation. Harry Hershfield 10
- Abe Kabibble Dictates a Letter (Abe the Agent Series)—Recitation. Harry Hershfield 10
- A2908 When My Baby Smiles at Me—Fox-trot, Ted Lewis Jazz Band 10
- Rose of Washington Square (Intro. Jazz Babies' Ball)—Medley fox-trot. Kentucky Serenaders 10
- A2910 Who Wants a Baby (Intro.: I. I'm Waiting for Ships That Never Come In. II. A Little Bunch of Sweetness)—Medley fox-trot, Columbia Saxophone Sextette 10
- The Crocodile—Fox-trot, Columbia Saxophone Sextette 10
- A6147—Delilah (Intro. I'd Build a World in the Heart of a Rose)—Medley waltz, Columbia Orchestra 12
- In Shadowland—Waltz. Prince's Orchestra 12
- A6146 Mikado Medley—Overture, Philharmonic Orchestra of New York 12
- Mlle. Modiste Medley—Overture, Philharmonic Orchestra of New York 12

## AEOLIAN CO.

### OPERATIC SELECTIONS

- 45001 Pagliacci—Prologue (Leoncavallo). Baritone. Vocalion Orch. accomp. Giacomo Rinini 12
- 24004 I'll Take You Home Again, Kathleen (Westendorff). Vocalion Orch. accomp., Colin O'More and Male Trio 10
- Mary (Richardson). Tenor, Vocalion Orch. accomp. Colin O'More 10

### POPULAR SELECTIONS

- 24005 Pretty Little Cinderella (Vincent). Soprano, Vocalion Orch. accomp. Nellie and Sara Kouns 10
- Out of a Clear Sky (Rubini-Santrello). Soprano, Vocalion Orch. accomp. Sara Kouns 10
- 14048 Gypsy Land (Spencer). Orch. accomp. Sam Ash 10
- Smile Dear (Gebel). Orch. accomp., Henry Burr 10
- 14049 The Hen and the Cow (Meyer). Orch. accomp., Billy Murray 10
- At the Moving Picture Ball (Johnson-Santley). Orch. accomp. Billy Murray 10
- 14050 Throw Out that Mason and Dixon Line (Johnson-Hess). Orch. accomp. Peerless Quartet 10
- Melodious Jazz (Jerome). Orch. accomp., Peerless Quartet 10
- 14051 On Your Next Birthday (Drever). Orch. accomp. Sterling Trio 10
- Bye Lo (Perkins). Orch. accomp., Sterling Trio 10

### DANCE SELECTIONS

- 14052 La Veeda (John Alden)—Fox-trot, Harry A. Yerkes' Dance Orchestra 10
- The Crocodile (Motzah-Akst)—Fox-trot, Harry A. Yerkes' Dance Orchestra 10
- 14053 Unlucky Blues (Robinson)—Fox-trot, Palace Trio 10
- Missy, introd.: "Rainbow of my Dreams" (Stanton)—Fox-trot. Palace Trio 10

## EDISON AMBEROL RECORDS

### ROYAL PURPLE RECORDS

- 29050 Trämereri (Schumann)—Violin. Albert Spalding 10
- 29051 Life's Dream Is O'er (Adopted to "Alice Where Art Thou"). Soprano and Contralto, Marie Rappold and Carolina Lazzari 10

### REGULAR LIST

- 3967 He Went in Like a Lion and Came Out Like a Lamb (H. Von Tilzer). Al Bernard 10
- 3968 Triplets (G. H. Green)—Fox-trot. Xylophone, George Hamilton Green 10
- 3969 Flanagan's Troubles in a Restaurant—Vaudeville Specialty. Steve Porter 10
- 3970 Snoops, the Lawyer (Kalmar-Ruby), Maurice Burkhart 10
- 3971 Was There Ever a Pal Like You (Berlin). Tenor, George Wilton Ballard 10
- 3972 Old Fashioned Garden ("Hitchy-Koo 1919") (Porter). Contralto. Helen Clark and Chorus 10
- 3973 Buddha—Medley Fox-trot, for Dancing, Lenzberg's Riverside Orchestra 10
- 3974 There's Not a Song that Trembles, Cantilena (Rogers). Soprano and Contralto, Betsy L. Shepherd, Helen Clark and Mixed Chorus 10
- 3975 You Are Free ("Apple Blossoms" (Jacobi). Soprano and Tenor, Betsy Lane Shepherd and Lewis James 10
- 3976 When Honey Sings an Old-Time Song (Carey). Tenor. George Wilton Ballard 10
- 3977 Love's Rosary (Innella). Tenor. Charles Hart 10
- 3978 Hippity Hop (Donaldson). Male Voices, Premier Quartet 10
- 3979 Roll on Silver Moon (Ernest)—Yodel song, Frank M. Kamplain 10
- 3980 I Come from Get-It-Land (Bernard), Al Bernard and Ernest Hare 10
- 3981 Once Upon a Time ("Magic Melody") (Romberg). Tenor. Lewis James 10
- 3982 You're a Million Miles from Nowhere (When You're One Little Mile from Home) (Donaldson). Tenor. William Bonner 10
- 3983 Karavan (Wiedoeft)—Fox-trot, for Dancing, Lenzberg's Riverside Orchestra 10

- 3984 Aloha Sunset Land (Kawelo). 1st Soprano, 2d Soprano and Alto. Homestead Trio 10
- 3985 Oh, Gee!—Medley of Irish Reels, Accordion, John J. Kimmel 10
- 3986 For You (S. Smith). Contralto. Helen Clark 10
- 3987 Cruiskeen Lawn—Lily of Killarney (Benedict). Soprano. Leola Lucey and Mixed Quartet 10

## EDISON DISC RE-CREATIONS

- 82164 A May Morning (Denza) and At Parting (Rogers). Soprano. Julia Heinrich 10
- I Dreamt That I Dwell in Marble Halls—Bohemian Girl (Balfe). Soprano. Julia Heinrich 10
- 82186 On Wings of Music (Mendelssohn). Soprano, Marie Sundelius 10
- Vallat and Fjorton ar. Soprano, in Swedish, Marie Sundelius 10
- 80401 Charmant Oiseau (Thou Brilliant Bird)—La Perle du Brésil (David). Soprano, in French, Stella Power 10
- Spring (Henschel). Soprano. Stella Power 10
- 80847 By an' By. Arr. by Burleigh. Tenor, Reed Miller and Chorus 10
- Go Down, Moses (Let My People Go). Arr. by Burleigh. Tenor. Reed Miller and Chorus 10
- 80488 Divertimento—Il Convegno (Ponchielli). Clarinets. Anthony Giammatteo-Fred. J. Brissett 10
- Our Own Make Polka (Levy). Cornet, Jules Levy, Jr. 10
- 80499 Cruiskeen Lawn—Lily of Killarney (Benedict). Soprano and mixed voices, Leola Lucey and Quartet 10
- We Parted (Glover). Soprano and contralto, Gladys Rice-Elizabeth Lennox 10
- 80500 Love's Adieu (Old Folk Song). Tenor and baritone. Lewis James-Vernon Archibald 10
- There's Not a Song That Trembles, Cantilena (Rogers). Soprano, contralto and mixed voices. Betsy L. Shepherd, Helen Clark and Chorus 10
- 80502 In a Bird Store—Descriptive Fantasia (Lake), American Symphony Orchestra 10
- Wooing Hour—Serenade (Zamecnik), Peerless Orchestra 10
- 80519 Annie Laurie (Geibel Arrangement). Male voices. Criterion Quartet 10
- We Strongly Now Will Try Together—La Fille de Madame Angot (Lecocq). Soprano and tenor. Gladys Rice-Vernon Dalhart 10
- 80520 In the Garden (Miles). Male voices, Apollo Quartet of Boston 10
- List! The Cherubic Host—Holy City (Gaul), Thomas Chalmers and Chorus of Women's Voices 10
- 50635 Aloha Land (Hawaiian Waltz) (Herzer), Waikiki Hawaiian Orchestra (With Louise-Ferera) 10
- Wait Until the Roses Bloom (Morgan). Saxophone. Wheeler Wadsworth 10
- 50636 At a Georgia Camp Meeting (Mills), New York Military Band 10
- Liberty Bell March (Sousa), New York Military Band 10
- NOUVELLES RE-CREATIONS FRANCAISES
- 74004 Ah! lève-toi, soleil!—Roméo et Juliette (Gounod). Tenor. P. A. Asselin 10
- Anges du paradis—Mireille (Gounod). Tenor, P. A. Asselin 10
- 74004 Anges du paradis—Mireille (Gounod). Tenor, P. A. Asselin 10
- Ah! lève-toi, soleil!—Roméo et Juliette (Gounod). Tenor. P. A. Asselin 10
- 74005 Arioso (O mer, ouvre-toi) (Delibes). Tenor, P. A. Asselin 10
- O souverain, ô juge, ô père—Le Cid (Massenet). Tenor. P. A. Asselin 10
- 58001 Baiser (Le) (Jette). Baritone. Hector Pellerin 10
- C'est Rosalie (Jack-Brill). Baritone. Hector Pellerin 10
- 58004 Belle au Bois Dormant (La) (Vieu). Baritone. Hector Pellerin 10
- Presque vertueuse (Gabaroché). Baritone, Hector Pellerin 10
- 74002 Cantique de Noël (Adam). Tenor. P. A. Asselin 10
- O Salutaris (Salomé). Tenor. P. A. Asselin 10
- 58005 C'est pour vous! (Berlin). Baritone, Hector Pellerin 10
- Demain qui n'est jamais venu (Popy et Piccolini). Baritone. Hector Pellerin 10
- 58001 C'est Rosalie (Jack-Brill). Baritone. Hector Pellerin 10
- Le Baiser (Jette). Baritone. Hector Pellerin 10
- 58003 Cocardes de Mimi Pinson (La) (Marinier et Heintz). Baritone. Hector Pellerin 10
- La Mimosa (Brarirolli). Baritone. Hector Pellerin 10
- 58006 Credo du Paysan (Le) (Goublier). Baritone, Orphée Langevin 10
- O Candal mon apys, mes amours! (Mercier). Baritone. Orphée Langevin 10
- 58005 Demain qui n'est jamais venu (Popy et Piccolini). Baritone. Hector Pellerin 10
- C'est pour vous! (Berlin). Baritone. Hector Pellerin 10
- 58002 Elle était vendeuse (Serpieri). Baritone, Hector Pellerin 10
- J'aime une brune (Christiné). Baritone, Hector Pellerin 10
- 74003 Elle ne croyait pas—Mignon (Thomas). Tenor, P. A. Asselin 10
- Le Rêve—Manon (Massenet). Tenor. P. A. Asselin 10
- 58002 J'aime une Brune (Christiné). Baritone, Hector Pellerin 10
- Elle était vendeuse (Serpieri). Baritone, Hector Pellerin 10
- 74001 L'Adieu du Matin (Pessard)—Priez, aimez, chantez (Gregb). Tenor. P. A. Asselin 10
- Madrigal (Chaminade)—Tu ne dirais (Chaminade). Tenor. P. A. Asselin 10
- 74001 Madrigal (Chaminade)—Tu me dirais (Chaminade). Tenor. P. A. Asselin 10
- L'Adieu du Matin (Pessard)—Priez, aimez, chantez (Gregb). Tenor. P. A. Asselin 10
- 58007 Marseillaise (La) (Rouget De Lisle). Baritone, Orphée Langevin 10
- Le Saint-Laurent (Mercier). Baritone, Orphée Langevin 10
- 58003 Mimosa (La) (Barrirrolli). Baritone. Hector Pellerin 10
- La Cocardes de Mimi Pinson (Marinier et Heintz). Baritone. Hector Pellerin 10
- 58006 O Canada! non pays, mes amours! (Mercier). Baritone. Orphée Langevin 10
- Le Credo du Paysan (Goublier). Baritone, Orphée Langevin 10

(Continued on page 244)



ADVANCE RECORD BULLETINS FOR MAY—(Continued from page 243)

PATHE FRERES PHONOGRAPH CO.

POPULAR SUPPLEMENT NO. 32

VOCAL

- 22331 My Golden Girl (Krummer-Herbert). Tenor, Sam Ash 10
- Beautiful Hawaiian Love (Terriss-Bridges). Tenor duet. Campbell and Burr 10
- 22332 Mystery! (Johnson-Cirina). Soprano. Patricola 10
- All the Boys Love Mary (Sterling-Van Schenck). Soprano. Patricola 10
- 22333 Daddy, You've Been a Mother to Me (Fisher). Tenor. Henry Burr 10
- Underneath the Southern Skies (Behim-Ruby-Jerome). Tenor and Baritone, Henry Burr and John Myers 10
- 22334 Buddha (Rose-Pollack). Peerless Quartet 10
- I'm Always Falling in Love with the Other Fellow's Girl (Caesar-Meyer). Tenor, Sam Ash 10
- 22335 It's Hard to Settle Down to Civilian Life Once More (Weston-Lee). Baritone, piano accomp., Jack Norworth 10
- Argentines, Portuguese and Greeks (Swanstrum-Morgan). Baritone. Jack Norworth 10
- 22337 If You Could Care (from "As You Were") (Wimperis-Darewski). Tenor. Lewis James 10
- Venetian Dreams (Garrett-Klickman). Tenor duet. Lewis James and Charles Hunt 10
- 22338 Ching-a-Ling's Jazz Bazaar (Johnson-Bridges). Shannon Four 10
- I'll Always Keep a Corner in My Heart for Tennessee (Clarke-Donaldson). Baritone, Turner Roe 10
- 22324 Sweet and Low (Royce-Johnson). Royal Waikiki Hawaiian Orchestra 10
- Carolina Sunshine (Hirsch-Schmidt). Royal Waikiki Hawaiian Orchestra 10
- DANCE RECORDS
- 22321 Please (Roberts-Callahan)—Medley Fox-trot, Intro.: "Patches".....Wiedoeft's Palace Trio 10
- Desert Dreams (Lewin)—Fox-trot, Wiedoeft's Palace Trio 10
- 22339 Crocodile (Motzan-Akst)—Fox-trot, Nicholas Orlando's Orchestra 10
- Somebody (Little-Stanley-Dellon)—One-step, Nicholas Orlando's Orchestra 10
- 22340 Happy (Frey)—One-step, Jacob's Dance Orchestra 10
- Syncopated Heart (Stothart)—Medley Fox-trot, Intro.: "Drifting".....Jacob's Dance Orchestra 10
- 22341 Bound in Morocco (Herscher)—Fox-trot, All Star Trio 10
- The Last Part of Every Party (from "Irene") (McCarthy-Tierney)—Medley Fox-trot, Intro.: "The Sky-Rocket".....All Star Trio 10
- 22346 Left All Alone Again Blues (from "The Night Boat") (Kern)—Medley Fox-trot, Intro.: "Good-Night Boat".....Van Eps-Banta Trio 10
- When the Wedding Bells Are Ringin' (from "Apple Blossoms") (Jacobi)—Medley Fox-trot, Intro.: "Little Girls Good-Bye" Van Eps-Banta Trio 10
- 22343 Just Another Kiss (Hilbert)—Waltz, Casino Dance Orchestra 10
- Venetian Moon (Goldberg-Magine)—Fox-trot, Casino Dance Orchestra 10
- 22347 Rose of Washington Square (Hanley)—Fox-trot, Della Robbia Orch (Max Fells, Director) 10
- Oriental Stars (Monaco)—One-step, Della Robbia Orchestra (Max Fells, Director) 10

Regular May Pathé List

OPERATIC VOCAL RECORDS

- 54043 Suor Angelica (Puccini) "Senza Mamma" (Without Mother) in Italian. Soprano, Claudia Muzio 12
- 60084 La Bohème (Puccini) "In Poverta mia lieta" (In Poverty I Live). Tenor, in Italian, Aristodemo Giorgini 12
- Voce e' Notte (Neapolitan Folk Song) (de Curtis). Tenor, in Italian. Aristodemo Giorgini 12
- 60088 Norma (Bellini) "Casta Diva" (Queen of Heaven). Soprano, in Italian. Rosa Raisa 12
- Il Trovatore (Verdi) "D'amour sull' ali rosee" (Love, Fly on Rosy Pinions). Soprano, in Italian. Rosa Raisa 12
- STANDARD SONGS SUNG IN ENGLISH
- 22313 The Pilot (Noyes-Protheroe). Piano accomp., Haydn Glee Club of Utica, N. Y. 10
- The Jolly Blacksmith's Lay (Geibel). Piano accomp., Haydn Glee Club of Utica, N. Y. 10
- 22294 Asthore (Bingham-Trotère). Baritone, Elliott Shaw 10
- Mollie Darling (Hays). Tenor. Charles Hart 10
- 22296 Oh! That We Two Were Maying (Nevin). Contralto and Baritone, Virginia Thatcher and Turner Roe 10
- Gypsy Love Song (Slumber On My Little Gypsy Sweetheart) (Smith-Herbert). Baritone, Elliott Shaw 10
- 25039 Her Danny (Byers-Schonberg). Tenor, Ernest Davis 10
- Down Limerick Way (Gartlan). Tenor, Ernest Davis 10
- 22314 The Trumpeter (Barron-Dix). Tenor, William Rubinoff 10
- I Hear a Thrush at Eve (Eberhart-Cadman). Tenor. William Rubinoff 10

NEW INSTRUMENTAL RECORDS

- 27027 To Spring (Grieg). Piano solo. Rudolph Ganz 10
- Perpetual Motion (Weher). Piano solo, Rudolph Ganz 10
- 52049 Liebslied (Kreisler). Violin solo, Alexander Debruilé 12
- Indian Lament (Dvorak-Kreisler). Violin solo, Alexander Debruilé 12
- 40197 Extase (Ganne). Violin, Cello, Piano, The Tollensfen Trio 12
- Serenade (Widor). Violin, Cello, Piano, The Tollensfen Trio 12
- NEW BAND AND ORCHESTRA RECORDS
- 22315 Blaze of Glory (Holzman). March, Imperial Infantry Band of England 10
- Cochecho (Recves) "An Alaskan Serenade," Imperial Infantry Band of England 10
- 22311 Sambre et Meuse (D'efile). March, Garde Republicaine Band of France 10
- The Cadets (Sousa). March, Garde Republicaine Band of France 10
- 22298 Castanets, "Spanish Dance," Native Brazilian Orchestra 10
- Shepherd's Song, "Old Melody," Native Brazilian Orchestra 10

GENNETT LATERAL RECORDS

- 2504 Missouri Waltz (Logan), J. H. Squire's Karsine Orchestra of London 12
- Beautiful Ohio (Mary Earl)—Waltz, Vincent's Band of London 12
- 9024 Who Wants a Baby? (Yellen-Olman)—Fox-

- trot...Bennie Krueger's Melody Syncopaters 10
- O-Oh-O-Oh-O-Oh (Gay-Johnson)—Fox-trot, Green Bros. Xylophone Orchestra 10
- 4624 All That I Want Is You (Monaco-Goodwin). Tenor, with orch. Fred Whitehouse 10
- Oh How I Laugh (When I Think How I Cried About You) (White). Tenor, with orch., Billy Jones 10
- 9029 He Went in Like a Lion (Von Tilzer). Tenor, with orch. Billy Murray 10
- C-U-B-A (Berlin). Tenor, with orch., Billy Murray 10
- 9030 Afghanistan (Wilander-Donnelly). Tenor, with orch. Arthur Hall 10
- If You're Only Fooling Round Me (Bennett). Tenor, with orch. Arthur Hall 10

OKEH RECORDS

(Ten-inch records)

- 4079 I'll See You in C-U-B-A. Tenor, with Rega orch. Billy Murray 10
- 4081 See Old Man Moon Smile. Baritone duet, Al. Bernard-Ernest Hare 10
- 4082 Chasin' the Blues. Baritone. Al. Bernard 10
- All I Want Is You. Tenor, with orch. Henry Burr 10
- When My Baby Smiles. Baritone, with orch., Bert Franklin 10
- 4083 Old Fashioned Garden. Tenor, with orch., Sam Ash 10
- Venetian Moon. Baritone, with orch., Joseph Phillips 10
- 4084 Melodious Jazz. Vocal quartet, with Regal orch., Peerless Quartet 10
- He Went in Like a Lion and Came Out Like a Lamb. Tenor, with orch. Billy Murray 10
- 4080 My Isle of Golden Dreams—Waltz, Joe Thomas' Sax-o-tette 10
- In and Out—One-step. Joe Thomas' Sax-o-tette 10
- 4085 See-Saw (Intro. "When Two Hearts Discover," from Musical Comedy, "See-Saw")—Fox-trot, Green Brothers' Xylophone Orch. 10
- Korinthia—One-step, Joseph Knecht's Waldorf Astoria Dance Orchestra 10
- 4086 Lone Star (Intro.: "Just Say the Word")—Fox-trot, Rudy Wiedoeft's Palace Trio 10
- Desert Dreams—Fox-trot. Selvin's Novelty Orchestra 10
- 4087 Afghanistan—Fox-trot. Selvin's Novelty Orchestra 10
- Buddha (My Own)—Fox-trot. Van Eps Quartet 10
- 4088 Waiting Under Western Skies—Waltz, Green Brothers Xylophone Orchestra 10
- Somebody—Novelty One-step, Rega Dance Orchestra 10

EMERSON PHONOGRAPH CO.

STANDARD 10-INCH GOLD SEAL

TIMELY SONG HITS

- 10136 The Bells of St. Mary's (Furber-Adams)—Tenor solo, orch. comp. Walter Scanlan 10
- I'm Waiting for Ships That Never Come In (Yellen-Olman)—Tenor solo, orch. comp., Jewis James 10
- 10140 Venetian Moon (Kahn-Goldberg-Magine)—Male trio, orch. comp. Sterling Trio 10
- If You're Only Fooling 'Round Me, Why Don't You Put Me Wise? (Geo. J. Bennett)—Comedy song, orch. comp. Irving-Jack Kaufman 10
- 10145 You're a Million Miles From Nowhere When You're One Little Mile From Home (Lewis-Young-Donaldson)—Tenor solo, orch. comp., Walter Scanlan 10
- Somebody (Little-Stanley-Dellon)—Tenor solo, orch. comp. Walter Scanlan 10
- 10147 Peggy (Williams-Moret)—Baritone solo, orch. comp. Arthur Fields 10
- When My Baby Smiles (Irving Berlin)—Tenor solo, orch. comp. Irving Kaufman 10
- 10148 When My Baby Smiles at Me (Sterling-Lewis-Munro)—Baritone solo, orch. comp. Arthur Fields 10
- Oh! How I Laugh When I Think How I Cried About You (Jessell-Turk-White)—Novelty song, orch. comp. Arthur Fields 10
- 10134 Oh! The Last Rose of Summer Was the Sweetest Rose of All (Ruby-Cantor-Ponce)—Comedy song, orch. comp. Eddie Cantor 10
- You Ain't Heard Nothing Yet (Kahn-DeSylvia-Jolson)—Comedy song, orch. comp. Eddie Cantor 10
- 10135 Hand in Hand Again (Egan-Whiting)—Tenor and baritone duet, orch. comp., Charles Hart-Elliott Shaw 10
- Once Upon a Time (Kummer-Romberg)—Tenor solo, orch. comp. Lewis James 10
- 10150 Was There Ever a Pal Like You? (Irving Berlin)—Tenor solo, orch. comp. William Robyn 10
- All That I Want Is You (Goodwin-Monaco)—Tenor solo, orch. comp. Sam Ash 10
- 10137 Sunny Weather Friends (Kendis-Brockman)—Baritone solo, orch. comp. Arthur Fields 10
- Lucy Dancing Around the Cabin Door (Farrell-Robinson)—Tenor and baritone duet, orch. comp. Irving-Jack Kaufman 10
- 10138 O (Oh!) (Gay-Johnson)—Comedy song, orch. comp. Billy Murray 10
- That Wonderful Kid From Madrid (MacDonald-Osborne)—Character song, orch. comp., Billy Murray 10
- 10149 When You're Alone (West-Spencer)—Tenor solo, orch. comp. Irving Kaufman 10
- Sunny Florida (Blanco-Schmidt)—Tenor solo, orch. comp. Walter Scanlan 10
- 10143 I Know What It Means to Be Lonesome (Kendis-Brockman-Vincent)—Tenor solo, orch. comp. William Robyn 10
- Only (Caesar-Akst)—Tenor solo, orch. comp., Walter Scanlan 10
- LATEST DANCE HITS
- 10146 Venetian Moon (Goldberg-Magine)—Fox-trot, Plantation Jazz Orch. 10
- Rose of the Orient (Gerald Arthur)—Fox-trot, Plantation Jazz Orch. 10
- 10133 Yellow Dog Blues, Medley (Intro. "A Good Man Is Hard to Find") (Handy-Green)—Fox-trot, Selvin's Novelty Orch. 10
- In Shadowland (J. S. Brothers, Jr.)—Waltz, Selvin's Novelty Orch. 10
- 10139 Bo-La-Bo (George Fairman)—Fox-trot, Emerson Xvlo-Phiends 10
- Sweet and Low (Charles L. Johnson)—Waltz, Sanford's Famous Dance Orch. 10
- 10142 P'casc (Callahan-Roberts)—Fox-trot, Emerson Military Band 10
- My Baby's Arms (Harry Tierney)—Fox-trot, Emerson Military Band 10
- 10141 O (Oh!) (Gay-Johnson)—Fox-trot, Plantation Jazz Orch. 10
- Song of Omar (Leo Edwards)—Fox-trot, Plantation Jazz Orch. 10
- 10151 I Might Be Your Once-in-a-While (Victor Herbert)—Fox-trot, All Star Trio 10
- While Others Are Building Castles in the Air, Medley (Intro. "Just for Me and Mary") Fisher-Leo Edwards)—Fox-trot, All Starr Trio 10

- 10152 Pretty Little Rainbow (Vincent C. Plunkett)—Waltz, saxophone and xylophone duet, orch. accomp. George Hamilton Green-Rudy Wiedoeft 10
- Mavis (Peter DeRose)—Waltz, saxophone and xylophone duet, orch. accomp., George Hamilton Green-Rudy Wiedoeft 10
- 10144 The Black Bird—Medley of Irish horn pipes, accordion solo John Kimmel 10
- Lakes of Kildare—Medley of Irish jigs, accordion solo John Kimmel 10
- 10153 Afghanistan—Oriental hallad, orch. accomp., Premier-American Quartet 10
- They Called It the Dixie Blues—Blues, orch. accomp. Bert Harvey 10
- 10154 When the Harvest Moon Is Shining—Male trio, orch. comp. Sterling Trio 10
- I'm Waiting for To-morrow to Come—Tenor solo, orch. comp. Reed Miller 10
- 10158 I'll See You in Cuba—Male trio, orch. comp., The Three Kauffields 10
- Karavan—Tenor and baritone duet, orch. comp. Irving-Jack Kaufman 10
- 10159 Daddy, You've Been a Mother to Me—Contralto solo, orch. comp. Dolly Connolly 10
- Pickaninny Blues—Male trio, orch. comp., Sterling Trio 10
- 10155 Mystery—Fox-trot. Sanford's Famous Dance Orch. 10
- Far East—Waltz. Sanford's Famous Dance Orch. 10
- 10156 Oriental Stars—Fox-trot, George Hamilton Green's Novelty Orch. 10
- Missy, Medley—Fox-trot, accordion, piano and saxophone. The Palace Trio 10
- 10157 Railroad Blues—Fox-trot. Plantation Jazz Orch. 10
- Ching-a-Ling's Jazz Bazaar—Fox-trot, Plantation Jazz Orch. 10
- 10160 Rose of Washington Square—Fox-trot, Murray's Melody Men 10
- Toreador—One-step. Continental Military Band 10

EMERSON INTERNATIONAL, INC.

PREMIER INTERNATIONAL AND FOREIGN

- 13053 Fun Eilenish Kunt Kein Guts Arous. Tenor, Abe Rosenstein 10
- Got Gib Adreh Dus Reidel. Tenor. Abe Rosenstein 10
- 13054 Umipnei Chatoeinu—Part 1. Tenor, Rev. Wm. Alperovitz 10
- Umipnei Chatoeinu—Part 2. Tenor, Rev. Wm. Alperovitz 10
- 13055 Beim Rebe's Seudes. Ab. Schwartz's Yiddisher Orch. 10
- Sadigurer Chosid'l. Ab. Schwartz's Yiddisher Orch. 10
- 13056 Yente Fregt Die 4 Kashes. Duet, Gus Goldstein-Clara Gold 10
- Mendel Recht Dem Seder. Duet, Gus Goldstein-Clara Gold 10
- 13057 Rachmono. Wm. Alperovitz 10
- Eli Eli Lomo Asavtoni. Tenor. Ephraim Duff 10
- 12060 Stornelli Amari. Orch. accomp. Narciso De Charny 10
- Tammurriata Napulitana. Orch. accomp., Narciso Guida 10
- 12061 So Malandrino. Orch. accomp. Narciso-Ietti 10
- Napule e' Sempe Napule. Orch. comp., Barbieri Cannio 10
- 12059 'O Festino. Orch. comp. P. Vento-E. A. Mario 10
- 'A Legge. Orch. comp. P. Vento-E. A. Mario 10
- 12058 Fenesta 'e Nfamita. Orch. comp., Pasqualotto-Quaranta 10
- 'A nfama 'e Marechiaro. Orch. comp., Pasqualotto-Quaranta 10
- 20044 The Last Rose of Summer (Moore), International Quartet 10
- The Swan—Le Cigne (Saint Saens), International Quartet 10
- 20045 The Rosary. Nevin 10
- Deep River. Negro Melody 10
- 20046 The Evening Star. R. Wagner 10
- Melody in F. Rubenstein 10
- 20047 William Tell Overture—Part 1 (Rossini), Thaviu's Band 10
- William Tell Overture—Part II (Rossini), Thaviu's Band 10
- PIESNI WOJENNE
- 11050 Marsz Strzelców. T. Wronski 10
- Grzmia, Pod Stoczkim Armaty. Orch. comp., T. Wronski 10
- 11051 Piosnka Zolnierska. T. Wronski 10
- O. Mój Rozmarynie. T. Wronski 10
- 11052 Ostatni Mazurek. T. Wronski 10
- Mazurek Trzeciego Maja. T. Wronski 10
- 11053 Walecznych Tysiac. Orch. comp. T. Wronski 10
- Marsz Sokolów. Orch. comp. T. Wronski 10

PARAMOUNT RECORDS

DANCE RECORDS

- 20007 Afghanistan (Wilander-Donnelly)—Fox-trot, Selvin's Novelty Orchestra 10
- Venetian Moon (Kahn-Goldberg-Magine)—Fox-trot, Selvin's Novelty Orchestra 10
- 20008 Irene Medley (Intro.: "Skyrocket")—Fox-trot, Selvin's Novelty Orchestra 10
- Desert Dreams (Leonard Lewin)—Fox-trot, Selvin's Novelty Orchestra 10
- 20009 I'll See You in C-U-B-A (Berlin)—Fox-trot, All Star Trio 10
- When My Baby Smiles at Me (Louis-Sterling-Munro)—Fox-trot, All Star Trio 10

VOCAL RECORDS

- 20010 Oh! Gay-Johnson). Tenor solo. Billy Murray 10
- Saxophone Blues. Vocal solo, with Saxophone solo by Rudy Weidoeft. Al Bernard 10
- 20011 Pickaninny Blue (Frost-Klickman). Tenor solo, orch. comp. Henry Burr 10
- I'm Waiting for My Tomorrow to Come (Davis-Hawelka-Prival). Vocal solo, orch. comp., Marion Evelyn Cox 10
- 50030 Lassie O'Mine. Tenor solo. Earnest Davis 10
- Bring Back the Golden Days. Tenor solo, Earnest Davis 10

INSTRUMENTAL RECORDS

- 30061 I Might Be Your Once-in-a-While (Herbert-Smith) (Intro.: "Wild Oats")—Medley Fox-trot, American Marimba Players 10
- On Miami Shore (LeBaron-Jacobi)—Waltz, American Marimba Players 10
- 30060 Aloha Land (Hawaiian Guitars, Flute Obligato), Louise, Ferera and Rose 10
- First Love. Accordion solo. Delroy 10

OPERAPHONE CO., INC.

POPULAR VOCAL

- 21156 Beautiful Hawaiian Love (Terriss-Bridges). Tenor duet, orch. comp. Campbell and Burr 10
- I Am Waiting for Tomorrow to Come (Davis-Hawelka-Prival). Baritone, orch. comp., Edward Kane 10
- 21157 Alice Blue Gown (from "Irene") (McCarthy-Tierney). Contralto, orch. comp. Louise Gaither 10
- Buddha (Rose-Pollack). Orch. comp., Peerless Quartet 10
- 21158 Daddy, You've Been a Mother to Me (Fisher). Tenor, orch. comp. Henry Burr 10



# Some Leading Jobbers of Talking Machines in America

**WM. H. REYNALDS**  
DISTRIBUTORS OF  
**Victrolas and Victor Records**  
MOBILE, ALA.

**RECORD BULLETINS FOR MAY**  
(Continued from page 244)

- If You Could Care (from "As You Were") (Wimperis-Darewski). Tenor, Orch. accomp., Lewis James
- 21159 Ching-a-Ling's Jazz Bazaar (Johnson-Bridges). Orch. accomp. Shannon Four  
So Long Go Long (Kalmar-Ruby). Tenor, Orch. accomp. Russell Paige
- 21160 Jazz Babies' Ball (Bayha-Pinkard). Tenor, Orch. accomp. Wilbur Fairbanks  
Oh! By Jingo! Oh! By Gee! (Brown-Von Tilzer) Tenor, Orch. accomp. Douglas Scott
- DANCE**
- 31138 Crocodile (Motzan-Akst)—Fox-trot, Elite Dance Orchestra  
Just Another Kiss (Hilbert)—Waltz, Elite Dance Orchestra
- 31139 Somebody (Little-Stanley-Dellon)—One-step, Elite Dance Orchestra  
Venetian Moon (Goldberg-Magino)—Fox-trot, Elite Dance Orchestra
- 31140 When You're Alone (Spencer-West)—Fox-trot, Elite Dance Orchestra  
Bound in Morocco (Herscher)—Fox-trot, Jones' Novelty Dance Orchestra
- 31141 Blue Diamonds (Caddigan-Story)—Fox-trot, Elite Dance Orchestra  
Bow Wow (Wadsworth)—One-step, Southern Saxophone Band
- STANDARD VOCAL**
- 41109 Love's Old Sweet Song (Bingham-Holly). Contralto, Orch. accomp. Madeline Gilroy  
Oh! That We Two Were Maying (Nevin). Contralto and Baritone, Orch. accomp. Maude Gordon and Victor Churchill
- INSTRUMENTAL**
- 51131 Mighty Lak' a Rose (Nevin). Violin, Flute, Piano. Mendelssohn Trio  
Melodie, Op. 42 (Tschaiakowsky). Violin solo, Piano accomp. Albert Faber
- 51132 Woodland Dreams (Vargas). Operaphone Concert Orchestra  
Iris (Friml). Operaphone Concert Orchestra

**EMPIRE TALKING MACHINE RECORDS**

- UNIVERSAL CUT RECORDS**  
**POPULAR SONGS**
- 415 Venetian Moon (Kahn-Goldberg-Margini). Male Trio, Orch. accomp. Sterling Trio  
You're a Million Miles From Nowhere (Lewis-Young-Donaldson). Tenor, Orch. accomp. Sam Ash
- 416 When the Harvest Moon Is Shining (Sterling-Von Tilzer). Quartet, Orch. accomp. Shannon Four  
Was There Ever a Pal Like You (Berlin). Orch. accomp. Henry Burr
- 417 Pickaninny Blues (Frost-Klickman). Tenor, Orch. accomp. Lewis James  
Everyone Is Meant for Someone (Kalmar-Ruby-Rubini Santaella). Tenor Duet, Orch. accomp. Campbell and Burr
- 418 When You're Alone (West-Spencer). Male Quartet, Orch. accomp. Shannon Four  
How Sorry You'll Be (Wait'll You See) (Kalmar-Ruby). Tenor, Orch. accomp. Billy Murray
- 419 Mystery (Johnson-Cirina). Contralto, Orch. accomp. Jane O'Day  
I'm Always Falling in Love With the Other Fellow's Girl (Caesar-Meyer). Tenor, Orch. accomp. Sam Ash
- STANDARD SONGS**
- 420 Sleep, Baby, Sleep (Hadley). Tenor, Orch. accomp. Yodling Song. William McDonnell  
O Sole Mio! (Capurro-DiCapua). Tenor, Neapolitan Orch. accomp. Marion Costello
- HUMOROUS SONGS**
- 421 I'll See You in C-U-B-A (Berlin). Tenor, Orch. accomp. Billy Murray  
Oh, Mother, I'm Wild (Johnson-Pease-Nelson). Tenor, Orch. accomp. Bertram Smith
- INSTRUMENTAL SELECTIONS**
- 803 Cavaleria Rusticana (Intermezzo) (Mascagni). Violin Solo, Piano accomp. Alice Raymond  
Somewhere a Voice Is Calling (Tate). Violin, flute and piano. Mendelssohn Trio
- 804 Star Spangled Banner (Key). With Army Bugle Calls. Empire Military Band  
Flags of Freedom (Sousa). March. Empire Military Band
- DANCE SELECTIONS**
- 507 Ole Miss Blues (Handy). Fox-trot, Janes' Novelty Dance Orchestra  
Little Girls, Good-Bye (Jacobi). From "Apple Blossoms." One-step. Empire Dance Band
- 508 I Left My Door Open and My Daddy Walked Out (Berlin). Intro. "Nobody Knows and Nobody Cares." Medley Fox-trot, Brown's Dance Orchestra  
I Might Be Your Once in a While (Herbert). From "Angel Face." Intro. "Call It a Day." Novelty Dance Orchestra
- 509 Faust Waltz (Gounod). Accordion Duet, Delenti Brothers  
Golden Sunset (Hall)—Waltz, Accordion Duet, Delenti Brothers

W. W. O'Hara, Montreal, will remove on May 1 to 737 St. Catherine street west, where he will have four times the amount of space at his disposal. He will feature the Columbia line stronger than ever and put into force innovations previously impossible through lack of space.

**TEST IT.**   
OUR VICTOR  
**Record Service**

has a reputation for efficiency.  
Suppose you try it.

**E. F. DROOP & SONS CO.**  
1300 G. STREET, WASHINGTON, D. C.  
231 N. HOWARD STREET, BALTIMORE, MD



Where Dealers May Secure  
**COLUMBIA**  
Product

Ready, Full Stocks, and Prompt Deliveries  
from Convenient Shipping Centers  
all over the United States.

**Distributors**

- Atlanta, Ga., Columbia Graphophone Co., 63 N. Pryor St.
- Baltimore, Md., Columbia Graphophone Co., 16 South Howard St.
- Boston, Columbia Graphophone Co., 137 Federal St.
- Buffalo, N. Y., Columbia Graphophone Co., 733-35-37 Main St.
- Chicago, Ill., Columbia Graphophone Co., 14 N. Michigan Ave.
- Cincinnati, O., Columbia Graphophone Co., 427-429 W. Fourth Ave.
- Cleveland, O., Columbia Graphophone Co., 1378 Euclid Ave.
- Dallas, Tex., Columbia Graphophone Co., 1011 Elm St.
- Denver, Colo., Columbia Stores Co., 1608 Glenarm Place.
- Detroit, Mich., Columbia Graphophone Co., 401 Woodward Ave.
- Indianapolis, Ind., Columbia Graphophone Co., 207-217 W. Washington St.
- Kansas City, Mo., Columbia Graphophone Co., 1017 McGee St.
- Los Angeles, Cal., Columbia Graphophone Co., 745 S. Broadway.
- Minneapolis, Minn., Columbia Graphophone Co., 412-414 Nicollet Ave.
- New Haven, Conn., Columbia Graphophone Co., 206 Meadow St.
- New Orleans, La., Columbia Graphophone Co., 517-525 Canal St.
- New York City, Columbia Graphophone Co., 55 Warren St.
- Omaha, Neb., Schmolter & Mueller Piano Co., 1311 Farnum St.
- Philadelphia, Pa., Columbia Graphophone Co., 210 N. Broad St.
- Pittsburgh, Columbia Graphophone Co., 632-640 Duquesne Way.
- Portland, Me., Columbia Graphophone Co., 43 Exchange St.
- Salt Lake City, Utah, Columbia Stores Co., 221 South West Temple.
- San Francisco, Cal., Columbia Graphophone Co., 130-150 Sutter St.
- Seattle, Wash., Columbia Graphophone Co., 911 Western Ave.
- Spokane, Wash., Columbia Stores Co., 161 South St.
- St. Louis, Mo., Columbia Graphophone Co., 1127 Pine St.
- Tampa, Fla., Tampa Hardware Co.

Headquarters for Canada:

Columbia Graphophone Co., 54-56 Wellington St., West, Toronto Ont.

Executive Office

**COLUMBIA GRAPHOPHONE CO.**  
Woolworth Building New York

**W. J. DYER & BRO.**

DYER BLD'G, ST. PAUL, MINN.

NORTHWESTERN DISTRIBUTORS  
OF THE



**VICTOR**

Machines, Records and Supplies

Shipped Promptly to all  
Points in the Northwest

**Mickel Bros. Co.**

Omaha, Nebraska  
Des Moines, Iowa

**Victor Distributors**

**Sherman, Clay & Co.**

San Francisco, Los Angeles, Portland, Seattle, Spokane  
PACIFIC COAST DISTRIBUTORS OF  
VICTOR PRODUCTS

**The PERRY B. WHITSIT CO.**

Distributors of

**Victrolas and Victor Records**  
COLUMBUS, OHIO

**William Volker & Co.** Kansas City, Mo.; Houston, Tex., and Denver, Col.



DISTRIBUTORS

Complete Pathophone and Pathe Record Stocks.  
The best proposition for the progressive dealer.

**Victor Exclusively**  
**EASTERN TALKING MACHINE CO.**  
177 Tremont Street, Boston  
**VICTOR DISTRIBUTORS**



A · C · B · V · A · C · D · F · H · I · K · L · N · P · O · S · U · A · X · V · B · D · F · G · I · J · L · N · P · Q · S · U · V · X · Z · V · C · E · F · H · J · K · W · O · P · R · T · A · C · E · M · O · N

# INDEX TO ADVERTISERS

S · R · Q · O · M · K · V · H · F · E · C · V · B · C · E · F · H · J · K · W · O · P · R · T · U · W · Y · L · B · D · E · G · I · K · M · J · O · Q · S · T · V · M · Y · V · B · D

**A**

Acme Die Casting Corp. 125  
 Acme Engineering & Mfg. Co. 147  
 Acme Mica Co. 220  
 Acme Phono. Corp. 192  
 Adora Phono Co. 230  
 Aeolian Co. 100, 101  
 Aeolian Co., Chicago 144  
 Aeolian Co., Cincinnati 41  
 Amalgamated Phonograph Accessories Corp. 213  
 American Felt Co. 127  
 American Mica Works 67  
 American Phonograph Co. 208  
 American Walnut Mfrs. Assn. 227  
 Andrews, W. D., & C. N. 56  
 Ansonia Needle Co. 43  
 Armstrong Furn. Co. 54  
 Arrow Phono. Corp. 115  
 Astoria Mahogany Co. 42  
 Automatic Container Co. 67  
 Automatic Cover Support & Mfg. Co. 35

**B**

B & H Fibre Mfg. Co. 22  
 Badger State Cah. Co. 235  
 Badger Talking Machine Co. 118  
 Bagshaw Co., W. H. 84, 85  
 Barnhardt Bros. & Spindler 35, 93, 145  
 Beacon Phono. Co. 124  
 Beecroft, Clement 209  
 Belwin, Inc. 201  
 Blackman Talking Machine Co. 198  
 Bluebird T. M. Co., Insert following page 26  
 Bond's Graphophone Shop 215  
 Booth Felt Co., Inc. 82  
 Boston Book Co. 220  
 Brilliantone Steel Needle Co. 37  
 British Polyphon Co. 238  
 Brooks Mfg. Co. 195  
 Brown, McManus & Co. 219  
 Brunswick-Balke-Collender Co., Insert following page 10  
 Buehn Co., Louis. 97  
 Buffalo T. M. Co. 71  
 Bush & Lane Piano Co. 67

**C**

Cabinet & Accessories Sales Co. 193  
 Cardinal Phonograph Co. 57  
 Carpenter Paper Co. 127  
 Chappell's 202  
 Charmaphone Co. 33, 181  
 Cheney Talking Machine Co. 55  
 Cherington Mfg. Co. 145  
 Chicago Ferrottype Co. 156  
 Chicago Hinged Cover Support & Balance Co. 141  
 Chicago Metal Products Co. 204  
 Chicago Talking Machine Co. 134  
 Chorister Phono. Co. 161  
 Cirola Distr. Co. 197  
 Clark Co., John Elliott 35  
 Classified Want Ads. 234, 235  
 Cleveland T. M. Co. 15  
 Cole & Dunas. 154  
 Columbia Graphophone Co. 12, 13, 18, 27, 34, 43, 50, 54, 74, 81, 103, 113, 173, 196  
 Columbia Mantel Co. 183  
 Compton-Price Co., Insert following page 82  
 Condon & Co., Inc. 16, 17  
 Consolidated Music Co. 177  
 Consolidated Talking Machine Co. 143  
 Cox, Geo. Clay. 224  
 Crafts Piano Co., A. I. 190  
 Cressey & Allen. 90  
 Crippen Co., Inc. 52, 53  
 Crosley Phono. Co. 212  
 Curry, Frank B. 90

**D**

Delphoon Co. 118  
 DeMoll & Co., O. J. 120  
 Deterling Mfg. Co. 217  
 Ditson Co., Oliver. 81  
 Doctorow, D. R. 216  
 Dodin, Andrew H. 242  
 Doehler Die-Casting Co. 79  
 Droop & Sons Co., E. F. 245  
 Drying Systems, Inc. 116  
 Dulcitone Phonograph Co. 10  
 Duo-Tone Co. 72  
 Dyer & Bro., W. J. 245

**E**

Eastern Talking Machine Co. 83, 245  
 Echo Music Pub. Co. 201  
 Eclipse Musical Co. 34  
 Edison, Inc., Thos. A. Back Cover, 28, 106, 168  
 Efficiency Electric Co. 174  
 Einson Litho., Inc. 189  
 Eject-O-File Co., Inc. 187  
 Emerson International, Inc. 123  
 Emerson Philadelphia Co. 96  
 Emerson Phonograph Co. 112  
 Emerson Record Sales Co. 69  
 Emerson Sales Co., Pittsburgh. 24  
 Empire Phono. Parts Co. 205  
 Empire Talking Machine Co. 111  
 Endless-Graph Mfg. Co. 140  
 Esco Music & Accessories Co. 223  
 Everybody's Talking Machine Co. 98  
 Excel Cabinet Co. 178

**F**

Faultless Caster Co. 26  
 Favorite Mfg. Co. 234  
 Fisher, Co., Fred. 199  
 Fletcher-Wickes Co. 155  
 Fox Pub. Co., Sam. 200  
 Franklin Phonograph Co. 99  
 Fulton Talking Machine Co. 208

**G**

Gately-Haire Co., Inc. 179  
 General Phonograph Corp., Inserts following pages 18, 34, 66  
 General Phonograph Mfg. Co. 32, 216  
 General Sales Corp. 19  
 Gibson-Snow Co. 47  
 Glenwood Cabinet Co. 40  
 Globe Decalcomanie Co. 50

Glynn, W. D., Distributing Co. 47  
 Goldstein, C. M. 226  
 Gramophone Co., Ltd. 236  
 Grand Rapids Brass Co. 233  
 Grand Rapids Phonograph Co. 68  
 Grand T. M. Co., Inc. 185  
 Gray Co., Walter S. 93  
 Gray & Dudley Co. 45  
 Great Eastern Manufacturers Ass'n. 143  
 Gretsck Mfg. Co., Fred. 78  
 Grey Gull Records. 182  
 Griffith Piano Co. 47

**H**

Haag & Bissex. 114  
 Hallet & Davis Piano Co. 89  
 Handy Mfg. Co. 147  
 Harponola Co. 65  
 Hartzell, Geo. W. 170  
 Herbert & Huesgen Co. 82  
 Hessig-Ellis Drug Co. 47  
 Heywood Bros. & Wakefield Co. 62  
 Hiawatha Phono. Co. 20  
 Hillman & Son Phonograph Co. 47  
 Hinds, Hayden & Eldredge, Inc. 201  
 Hohson Miller Mfg. Co. 125  
 Hough, J. E., Ltd. 237  
 Hough, L. W. 89  
 Hunt, J. D., Mfg. Co. 233  
 Huss Bros. Phonograph & Piano Co. 121

**I**

Ilsley, Douhleday & Co. 72  
 Independent T. M. Co. 172  
 International Mica Co. 42  
 Iroquois Sales Co. 126

**J**

Jewel Phonoparts Co. 142  
 Jones-Motrola, Inc. 29  
 Jones Piano Co., E. H. 51

**K**

Kawin, Nat. 143  
 Kennedy-Green Co. 169  
 Kent Co., F. C. 11  
 Kesner & Jerlaw, Insert following page 42  
 Keystone Minerals Co. 26  
 Kiefer-Stewart Co. 47  
 Kirkman Engineering Corp. 18  
 Kraft, Bates & Spencer, Inc. 88  
 Krasherg Engineering & Manufacturing Corp. 25, 113

**L**

Lakeside Supply Co., Inc. 157  
 Lansing Co. 91  
 Lanski Co. 158  
 Lee-Cort-Andresen Co. 47  
 Lesley's 242  
 Lockwood, Vernon 239  
 Long Cabinet Co., Geo. 166  
 Lorentzen, H. K. 60  
 Lucky 13 Phonograph Co. 75, 76, 77  
 Lu-Franc Sales Service 45, 79  
 Lundstrom Mfg. Co., C. J. 92  
 Lyon & Healy. 136, 157  
 Lyons, J. I. 147  
 Lyraphone Co. of America 40

**M**

Magnavox Co. 47, 211  
 Magnola Talking Machine Co. 32, 67, 74, 130, 137  
 Mandel Mfg. Co., Inc. 146  
 Manhattan Phono. Parts Co. 70  
 Marshall & Co., C. L. 47  
 Marvelon Co. 58  
 Mastertone Phono Co. 219  
 Mellor's 163  
 Melodia Co. 218  
 Melodia Phonograph Co. 149  
 Mercantile Finance Co. 63  
 Mermod & Co. 202  
 Meyercord Co. 138  
 Mickel Bros. Co. 245  
 Minneapolis Drug Co. 47  
 Modernola Co. 80  
 Moeller-Waters Co. 117, 148, 204  
 Moir, C. C. 86  
 Montagnes, I., & Co. 47  
 Music Table Co. 210  
 Musical Products Co. 87  
 Musical Supply & Equipment Co. 47  
 Mutual T. M. Co. 70  
 Myers Replayer Co. 203

**N**

National Decalcomania Co. 98  
 National Publishing Co. 6  
 National Vitaphone Corp. 167  
 Natural Voice Phonograph Co. 130  
 Neu & Co., H. G. 181  
 New England Piano & Phono. Co. 91  
 New England Talking Machine Co. 90  
 Newman Bros. Co. 138  
 Newton-Elting Distr. Corp. 79  
 New York Talking Machine Co. 134  
 Northwest Phonograph Johners, Inc. 110  
 Nye, William F. 21

**O**

Ogden Sectional Cabinet Co., Inc. 159  
 Ohio Sales Co. 47  
 Onken Co., Oscar. 169  
 Oprrollo Co. 180  
 Ormes, Inc. 9  
 Oro-Tone Co. 149  
 Owen Co., Jr., Dennis B. 200

**P**

Pacific Phonograph Mfg. Co. 104, 105  
 Paramount Talking Machine Co. Inside Back Cover  
 Parks & Parks. 212  
 Parr Mfg. Co. 231  
 Pathé Frères Phonograph Co. 164, 165  
 Peabody, Henry W., & Co. 14  
 Pearsall Co., Silas E. 4  
 Peckham Mfg. Co. 50  
 Peerless Alum Co. 6  
 Peerless Record Makers. 173  
 Penn Phonograph Co. 95  
 Percphone Co., Ltd. 237

Perfect Automatic Brake Co. 155  
 Period Tone Arm Co. 211, 215, 225  
 Philadelphia Show Case Co. 48, 94  
 Phillips, Wm. 70  
 Phonograph Appliance Co. 130  
 Phonograph Supply Co. of New England. 90  
 Player Phone T. M. Co. 151  
 Playertone T. M. Co. 114  
 Pleasing Sound Phono. Co. 74  
 Plywood Corporation 209  
 Portable Phono. Co. 186  
 Precision Castings Co. 42  
 Prescott, F. M. 193  
 Presto Phono. Parts Corp. 66  
 Progressive Phonographic Supply Co. 217  
 Putnam-Page Co. 39

**R**

Reed Co. 121  
 Reflexo Products Co. 171  
 Regina Co. 18  
 Reilly Co., W. J. 194  
 Rene Manufacturing Co. 191, 208  
 Repeater Stop Co. 109  
 Repeat-O-Graph Co. 129  
 Rex Gramophone Co. 240  
 Reynolds, Wm. H. 245  
 Robinson, The Plater. 141  
 Robinson-Compton Co. 128  
 Robinson-Pettit Co. 47

**S**

Schloss Bros. 215  
 Schmelzer Arms Co. 23  
 Seahurg Mfg. Co. 228  
 Seehurg, J. P., Piano Co. 151  
 Sharmat & Son, S. W. 86  
 Sherman, Clay & Co. 245  
 Singer T. M. Co. 91  
 Smith Drug Co., C. D. 47  
 Smith, Kline & French Co. 47  
 Smith Laboratories, H. J. 218  
 Smith-Schiffin Co. 211  
 Solotone Mfg. Co. 98  
 Sona-Tone Phonograph, Inc. 110  
 Sonora Phonograph Sales Co., Inc., Inside Front Cover, 39, 46, 47  
 Soss Mfg. Co. 223  
 Sound Recording Co., Ltd. 239  
 Southern Drug Co. 47  
 Southern Sonora 47  
 Southwestern Drug Co. 47  
 Sphinx Gramophone Motors, Insert following page 50  
 Standard Accessory Corp. 119  
 Standard Paper Co. 188  
 Standard Talking Machine Co. 241  
 Starr Piano Co. 44  
 Stead & Co., J. 238, 240  
 Steel, W. R. 240  
 Steger & Sons Piano Mfg. Co. 139  
 Stein-Burn Corp. 131  
 Steinert, M., & Sons Co. 83  
 Steinola Co. 60  
 Stephenson, Inc. 214  
 Stern & Co., Jos. W. 202  
 Sterno Manufacturing Co. 232  
 Stewart Phonograph Corp. 184  
 Stewart T. M. Co. 189  
 Stodard Phono. Co. 175  
 Stoffer & Stackhouse. 30  
 Stone Piano Co. 222  
 Strevell-Paterson Hardware Co. 47  
 Superior Phonograph Co. 147  
 Supertone Needle Wks., Insert following page 98  
 Supreme Phono. Parts Co. 70  
 Swiss Jewel Co. 36

**T**

Talking Machine World Dealer Service. 206, 207  
 Thomas & Proetz Lumher Co. 218  
 Toledo Talking Machine Co. 63  
 Triangle Phono. Parts Co. 176  
 Tri-Sales Co. 103, 161

**U**

Udell Works 51  
 Unit Construction Co. 38  
 United Mfrs. & Dist. Co. 64  
 United Music Stores. 99  
 United Phonograph Corp. 160  
 Universal Fixtures Corp. 122  
 Universal Stamping & Mfg. Co. 152

**V**

Vacuum Record Lifter, Ltd. 61  
 Val Accessory House. 99  
 Van Houten, C. J., & Zoon. 47, 153  
 Van Veen & Co., Arthur L. 197  
 Venus Co. 74  
 Viconia Mfg. Co., Inc. 27  
 Victor Talking Machine Co. Front Cover, 5, 7  
 Vitanola Distributors Co. 96  
 Vitanola Talking Machine Co. 73  
 Vit Talking Machine Co. 150  
 Volker & Co., W. 245

**W**

Wade Co., R. C. 59  
 Wade & Wade. 135  
 Wade Talking Machine Co. 102  
 Wagner Phono. Co. 163  
 Walters & Barry Corp. 49  
 Ward Co., C. E. 50  
 Wathall Music Co. 47  
 Watson Bros. & Co. 89  
 Weber-Knapp Co. 107  
 Webster Novelty Mfg. Co. 108  
 Werlein, Ltd., Philip. 196  
 Weser Bros. 225  
 Weymann & Son, H. A. 98  
 Whitsit Co., Perry B. 245  
 Widdicomb Furniture Co. 162  
 Windsor Furniture Co. 31  
 Wolf, Clifford A. 226  
 Wonder T. M. Co. 66

**Y**

Yahr & Lange Drug Co. 47  
 Yates, Chas. H. 209

**Z**

Ziegler, Baker & Johnson. 78



# Sign Up for Paramount Co-Ordinated Products

**IMMEDIATE DELIVERY ASSURED**

Take advantage of the co-operation which the great Paramount Organization is equipped to give you. Build up your sales and profits with Paramount Talking Machines, Records, Needles and other accessories under one Trade Mark and Guarantee.

Sell one and you sell all by linking all together under the same name. Attractive dealer's proposition now ready. Apply to your nearest distributor.



Style XXX  
Retail at \$250  
Mahogany and  
oak

REG. U.S. PAT. OFF.

## Paramount

# Talking Machines & Records

### Advance List of May Releases

Two Hits to Every Record. All Records Lateral Cut.

20007 {	Afghanistan .....	Selvin	20011 {	Pickaninny Blues.....	Henry Burr
\$1.00 {	Venetian Moon .....	Selvin	\$1.00 {	I Am Waiting for To-morrow to Come.....	Marlon Evelyn Cox
20008 {	Irene Medley .....	Selvin	50030 {	Lassle O'Mine .....	Earnest Davis
\$1.00 {	Desert Oreams .....	Selvin	\$1.25 {	Bring Back the Golden Oays.....	Earnest Davis
20009 {	I Will Meet You in Cuba.....	All Star Trio	33060 {	Aloha Land—Hawaiian Guitars.....	Louise-Ferera-Rose
\$1.00 {	When My Baby Smiles at Me.....	All Star Trio	\$1.00 {	First Love—Accordion Solo.....	Delroy
20010 {	Oh! .....	Billy Murray	33061 {	I Might Be Your Once in a While.....	American Marimba Band
\$1.00 {	Saxophone Blues.....	Al Bernard and Rudy Weidoft	\$1.00 {	On Miami Shore.....	American Marimba Band



Style XV  
Retail at \$140  
Mahogany and  
oak

### DISTRIBUTORS

SHIPLEY-MASSINGHAM CO.,  
Pittsburgh, Pa.  
For Western Penna. and West Virginia.

THE OHIO PARAMOUNT CO.,  
6101 Euclid Ave., Cleveland, O.  
For Ohio.

E. R. GODFREY & SONS CO.,  
Milwaukee, Wis.  
For Iowa, Illinois, Michigan, Indiana and Wisconsin.

NORTH WEST PHONOGRAPH JOBBERS, INC.,  
915 Riverside Ave., Spokane, Wash.  
For Washington, North Oregon, North Idaho and West Montana.

C. E. WHITCOMB,  
315 Tyler St., Minneapolis, Minn.  
For Minnesota, North Dakota and South Dakota.

PECK & HILLS FURNITURE CO.,  
San Francisco, Cal.  
For California.

PECK & HILLS FURNITURE CO.,  
141 Madison Ave., New York City.  
For East New York, East Penna. and New Jersey.

Six Models of the Paramount. Immediate Delivery. Write to us or to your distributor  
*Mail the coupon now*

**The Paramount Talking Machine Co.**  
Port Washington, Wis.



Paramount Records are specially recorded in our fully-equipped laboratories in New York City.

### ORDER BLANK

For May Lateral Cut Paramount Records

Quantity	Record Number	Quantity	Record Number	Quantity	Record Number	Advertising
.....	20007	.....	20010	.....	33060	.....Supplements
.....	20008	.....	20011	.....	33061	.....Hangers
.....	20009	.....	50030	.....		.....Envelope Circulars
						.....Window Announcement

Check here Write us about available territory for Paramount Co-Ordinated Products

Date.....

Ship to .....

Order No. ....

City & State.....



To Edison Dealers:

# Watch For Your Jobber's Salesman!

He has with him a copy of the Portfolio shown here—the 1920 Sales Promotion Plans.

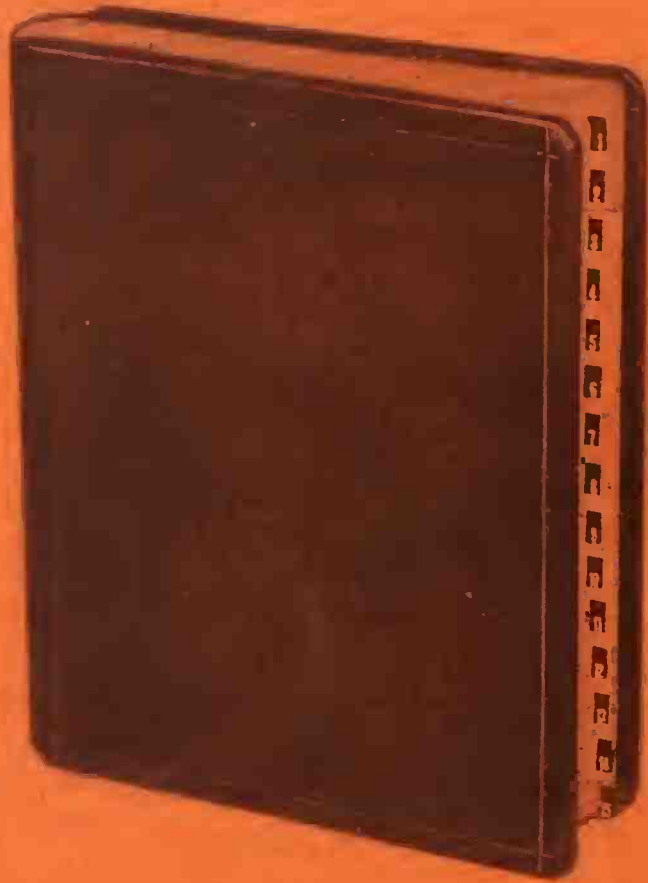

These plans were devised by the most able advertising men and sales authorities in the profession. They are made expressly for you—to enable you to make more sales.

Dealers who have signed up for various propositions are already getting results. You, too, will get results.

Watch for your Jobber's Salesman!

## THOMAS A. EDISON, Inc.

Orange, New Jersey

### JOBBER OF THE NEW EDISON, EDISON RE-CREATIONS, THE NEW EDISON DIAMOND AMBEROLA AND BLUE AMBEROL RECORDS

<b>CALIFORNIA</b> Los Angeles—Edison Phonographs, Ltd. San Francisco—Edison Phonographs, Ltd.	<b>LOUISIANA</b> New Orleans—Diamond Music Co., Inc.	<b>NEW YORK</b> Albany—American Phonograph Co. New York—The Phonograph Corp. of Manhattan. Syracuse—Frank E. Bolway & Son, Inc. W. D. Andrews Co. (Amberola only).	<b>TEXAS</b> Dallas—Texas-Oklahoma Phonograph Co.
<b>COLORADO</b> Denver—Denver Dry Goods Co.	<b>MASSACHUSETTS</b> Boston—Pardee-Ellenberger Co. Iver Johnson Sporting Goods Co. (Amberola only).	<b>OHIO</b> Cincinnati—The Phonograph Co. Cleveland—The Phonograph Co.	<b>UTAH</b> Ogden—Proudfit Sporting Goods Co.
<b>CONNECTICUT</b> New Haven—Pardee-Ellenberger Co., Inc.	<b>MICHIGAN</b> Detroit—Phonograph Co. of Detroit	<b>OREGON</b> Portland—Edison Phonograph Ltd.	<b>VIRGINIA</b> Richmond—The C. B. Haynes Co., Inc.
<b>GEORGIA</b> Atlanta—Phonographs, Inc.	<b>MINNESOTA</b> Minneapolis—Laurence H. Lucker	<b>PENNSYLVANIA</b> Philadelphia—Girard Phonograph Co. Pittsburgh—Buehn Phonograph Co. Williamsport—W. A. Myers.	<b>WISCONSIN</b> Milwaukee—The Phonograph & Co. of Milwaukee.
<b>ILLINOIS</b> Chicago—The Phonograph Co. James I. Lyons (Amberola only).	<b>MISSOURI</b> Kansas City—The Phonograph Co. of Kansas City. St. Louis—Silverstone Music Co.	<b>RHODE ISLAND</b> Providence—J. A. Foster Co. (Amberola only).	<b>CANADA</b> Montreal—R. S. Williams & Sons Co., Ltd. St. John—W. H. Thorne & Co., Ltd. Toronto—R. S. Williams & Sons Co., Ltd. Vancouver—Kent Piano Co., Ltd. Winnipeg—R. S. Williams & Sons Co., Ltd. Babson Bros. (Amberola only). Calgary—R. S. Williams & Sons Co., Ltd.
<b>INDIANA</b> Indianapolis—Kipp Phonograph Co.	<b>MONTANA</b> Helena—Montana Phonograph Co.		
<b>IOWA</b> Des Moines—Harger & Blish. Sioux City—Harger & Blish.	<b>NEBRASKA</b> Omaha—Schultz Bros.		