

The TALKING MACHINE WORLD

AND
NOVELTY
NEWS

Published Each Month by Estate of Edward Lyman Bill at 373 Fourth Ave., New York, March 15, 1916



Victrola XVI, \$200
Mahogany or oak

The instrument by which the value of
all musical instruments is measured



THE INSTRUMENT OF QUALITY

Sonora

CLEAR AS A BELL



1. Is it good?
2. Do the people want it?

When the answer to these two questions is *yes!* you've found the right phonograph to sell.

Investigate the Sonora.

We say it is "THE HIGHEST CLASS TALKING MACHINE IN THE WORLD."

Hear it and find out why.

Find out why the Jury of Awards at the Panama-Pacific Exposition "recommended that the Sonora Phonograph be given a marking for tone quality higher than that given to any other phonograph or talking machine."

Find out why our capacity is taxed to the utmost to fill orders.

Find out whether it is possible for you to be the Sonora agent in your territory.

Write us

SONORA PHONOGRAPH CORPORATION

GEORGE E. BRIGHTSON, *President*

General Offices and Salesrooms:

57 READE STREET

NEW YORK CITY

The Talking Machine World

Vol. 12. No. 3.

New York, March 15, 1916.

Price Twenty Cents

THE TEST OF THE TALKING MACHINE SALESMAN.

Time Is Here When He Is Called Upon to Make Comparisons Based Upon Accurate Mechanical Knowledge of Talking Machine Construction—The Business Sin of Uncertainty—Average Salesman Proves Capable of Meeting the New Situation Successfully.

The problems of talking machine salesmanship are not lessening with the increase of public interest and the investment of capital. On the other hand, the many new machines in the field, some selling at a low figure, are making it increasingly advisable for the salesman with an established house to study the basic principles, the mechanism, the selling points, not only of his machine, but of competing makes as well.

It frequently is necessary for a salesman to answer as directly as possible questions such as, "Why is your motor better than the Blank motor?"—"What real difference does the size of the diaphragm make?"—"Will your motor run as long without winding as the ——— motor?" Not very difficult inquiries, on the surface; but it may be ventured that many an otherwise efficient talking machine salesman would experience some difficulty in answering them fully on the basis of actual knowledge. In point of fact, the possibility has been proved by the experience of careful, want-to-know buyers who investigate several makes before selecting a machine. These buyers find that while most salesmen can demonstrate their own machines effectively, and know reasonably well how the effects are mechanically produced, when it comes to specific statements on one feature or another of construction which may differentiate a \$150 machine from a \$200 model of the same make, or may distinguish one make from another make, they show hesitancy or cover incomplete knowledge with generalization. And while such generalizations often are excusable on the ground of a desire to avoid comparisons with competing lines, they are perhaps more often due to partial ignorance. When a customer asks directly why one machine is better than another, the salesman may, with perfect business propriety, answer the inquiry as put to him. If he does not feel that his machine is superior to the other in any one particular, it is his privilege to extol another feature to overbalance the comparative weakness; but with a keen customer in hand he will gain no more by evading the question than by gratuitously knocking the rival make.

The Value of Certain Knowledge.

Possibly the worst sin of business ethics that a salesman can commit, and it is a prevalent sin, is destructive confession of a competing product concerning which his knowledge is uncertain. In the constant practice of the art of convincing a customer, salesmen are too apt to overlook the distinction between argument proper and argument plus imagination. If a customer who has listened attentively to a dissertation on faults in a rival machine concerning which he has asked questions, goes then to the competing company and asks for a thorough demonstration, obviously he hears a story quite opposite in some particulars. And with the rival machine before him, his eye assures his intelligence that the first salesman either wilfully misrepresented or displayed ignorance. Whichever it may have been, the customer is likely to look with more favor on the criticized machine, and even if his ultimate decision falls on the first, he will most likely purchase it at a store other than the one where the salesman misrepresented the competing machine.

Until talking machine concerns find it worth while to insist that their salesmen become conversant with at least the main mechanical and technical features of rival makes, that sort of back-and-forth misrepresentation is bound to continue. Instruction in the details of construction of the machine they are to handle is of course essential and is provided for by any concern that seriously

enters the selling field, but as yet it appears that even the large organizations have not arranged to have salesmen understand as far as possible the whole field. It is of course practically impossible that a man sell and study simultaneously, but with sufficient inducement a live salesman will go a great deal more deeply into his subject, and will look around a great deal more broadly than many talking machine salesmen apparently are doing to-day.

Making Clever Comparisons.

To be sure, there are brilliant exceptions; many of them. There are salesmen in New York talking machine stores who, without the least intention to knock and without the appearance of knocking, can so comprehensively explain before a customer the principal features of all important machines that when the talk is concluded the customer feels not only ready for and receptive to the arguments favoring the salesman's own machine, but actually prejudiced from a personal standpoint in the salesman's favor. Personality ought not to sell a talking machine that isn't as good as another at the same price, perhaps, but when much may be said on both sides the personal element and the element of broad knowledge will, naturally, help the salesman. A customer cannot help feeling that the salesman who knows the talking machine business thoroughly must also know his personal business well enough to have allied himself with a worth-while house. An accomplished, fact-justified salesman can talk intimately of a dozen competing machines in comparison with his own and give not the slightest impression of destructive criticism. It is the

E. N. SMITH OPENS NEW STORE.

Parkersburg Music Firm Opens Larger Quarters in Union Trust Building—Featuring the Edison and Aeolian-Vocalion.

(Special to The Talking Machine World.)

PARKERSBURG, W. VA., March 10.—The Smith Music Store recently moved from its lower Market street quarters to a new and larger store in the Union Trust Building, where it is giving special attention to the Edison Diamond Disc and Aeolian-Vocalion machines, for which it has the Parkersburg agency. The new store is beautifully furnished and decorated, the talking machine department being located on the right of the piano department. A large reception booth and two demonstration and sales booths are to be found in this department, a passageway which runs the entire length of the three booths being used to store the supply of records. In front of the booths is a miniature garden, with a porch swing. At one end is a large plate glass mirror, and various colored electric lights are used to help make the talking machine department attractive as well as useful.

A full line of pianos and players is carried by the store, separate demonstration rooms being provided for player demonstrations. A large overhead balcony, capable of seating a large audience, is used for talking machine recitals and tone tests. The proprietor and manager of the store, Edgar N. Smith, has been in the music trade in Parkersburg for the past ten years. He started in business in a store on Fourth street, shortly afterward moving to larger quarters on Market street. His trade eventually grew to such proportions that he was forced to seek a more commodious store, and his latest place was opened last month, an enormous crowd attending the opening. He is a firm believer in the value of publicity, and used a double page spread in the local newspapers to announce the

highest art of salesmanship, but it is an art attainable by businesslike determination and the practice of telling the customer what he wants to know.

It may be argued that a small store in a small town cannot be expected to employ salesmen trained in the general knowledge of one line, and particularly in a line so new and so broad as that of the talking machine. The argument is sound, for the most part; but the proprietor of a small store who takes on a line of talking machines can without difficulty secure literature from the manufacturer, and this literature he can offer to his customers together with what information he himself may have time to gather concerning other makes. It is certainly well within the province of his general business, even though he carries a great many different articles, to acquire the broadest possible knowledge in relation to each main line; and certainly there can be nothing but ultimate gain in the acquiring of familiarity with such a popular, moving and comprehensively priced a line as talking machines. The semi-rural customer who knows or thinks he knows pretty much what he wants, and takes exception to claims for the superiority of whatever line a local dealer handles, is ideal material both for the exercise of good salesmanship and for the testing of the advertising results and the general acquired reputation of different machines on the market. The dealer or the dealer's salesman or assistant who demonstrates successfully, either in pushing one line or in explaining the comparative virtues of several, gains the confidence which always brings business, whether on the spot, with his first effort, or the next day, or the next month.

Time for Salesmen to Wake Up.

In such cities as New York or Chicago it goes without saying that the talking machine salesman ought to acquire broad knowledge before attempting the actual diplomatic handling of customers.

opening of his new store and to call attention to the line of talkers and pianos he carries.

VICTOR ARTISTS IN CONCERT.

Irvin Riesenburger, a Victor dealer at 27 Main St., Flushing, N. Y., recently arranged for the appearance of a number of Victor artists at a concert and dance given for the benefit of St. Michael's Parochial School. This concert was a remarkable success and the hall secured for the purpose was too small to hold the enthusiastic music lovers who were desirous of hearing in person many of the artists whose records they had long admired.

Mr. Riesenburger was congratulated upon the success of the concert, as he had personally arranged every detail and had worked indefatigably to make the program worthy of the rare ability of the Victor artists in attendance.

Among the Victor artists who appeared at the concert were: Albert Campbell, Henry Burr, John Meyer, Arthur Collins, Vess Ossman, Bryan G. Harlan and others.

POPULAR IN CHURCH SERVICES.

(Special to The Talking Machine World.)

NEW LONDON, CONN., March 7.—The First Baptist Church of this city, Rev. Charles R. McNally, minister, is using a Columbia Grafonola in the services every Sunday, and the selections which are rendered are listed on the day's program and are also advertised in the daily newspapers. The names of the Columbia records used are mentioned, together with the artists who recorded them. This novelty in church music has elicited considerable attention from out-of-town visitors, and the members of the congregation seem to be delighted with the music rendered by the Grafonola.

SAN FRANCISCO DEALERS OPPOSE APPROVAL PLAN.

Local Association Passes Resolution Against Trade Evil—Many New Concerns Enter Pacific Coast Trade—Business Continues to Be Unusually Active—Oakland Store Places Large Columbia Order—Shortage of Stock in Some Lines Reported—News of Month.

(Special to The Talking Machine World.)

SAN FRANCISCO, CAL., March 4.—The rapid growth of the talking machine business on the Pacific Coast continues unchecked, February showing a decided spurt in business nearly everywhere. All the established jobbers or distributing stations give the same report of sales exceeding all records for this time of year, and several concerns new in this territory are opening up with every prospect of success. Scarcity of goods is the general complaint, and it looks as if the increased competition brought about by newcomers in the business would in reality be a great stimulus.

Association Discusses Approval Problem.

The local Talking Machine Dealers' Association met February 9, and the principal matter taken up was a continuation of the previous discussion of goods sent out on approval, the committee appointed for the purpose bringing in a set of resolutions which, with a few minor changes, were put through, declaring the association opposed to the practice of sending records on approval. Many wished to abolish the practice entirely, but some considered that action too drastic. The March meeting will be a banquet, and arrangements are being made for a well attended affair, all the employes of the stores being invited, and a number of interesting speakers will discuss trade topics. It will probably be held on the second Wednesday of March, but the place has not been definitely settled as yet.

Many New Comers Enter Trade.

The establishment of new talking machine concerns is the matter attracting most attention just now. The latest to open here is the Pathophone Shop, under the management of Louis Seely Blachly, formerly of Chicago, at 332 Post street. An attractive store has been fitted up and the location, opposite Union Square, should be a good one for the business. The place was opened February 26, and Mr. Blachly is starting an energetic introductory campaign. Arrangements are being made also to conduct a wholesale business, and a good-sized stock of records has been received and will soon be placed in a building on Stockton street. Local people have been getting acquainted with the Pathé for some time, and considerable interest is taken in the new venture.

Another new concern is the Stern Talking Machine Corp., which has just been incorporated, with a capital stock of \$50,000, by Ferderick and J. Stern, D. Hadsell, M. Duffy and J. G. Sweet.

The company has made all arrangements to handle the Rex talking machine line throughout the Pacific Coast territory. According to present plans, the first store will be on Market street and will be opened about April 1. Other stores will soon be added, and the company will establish a large number of agencies.

Gus Eilers, manager of the talking machine department of the Eilers Music House, has gone East for a visit to several of the manufacturers.

Columbia Co.'s Business Active.

Fred A. Dennison, district manager for the Columbia Graphophone Co., says business is in excellent shape all over his territory, and even better in the South than elsewhere. He spent the early part of the month in Los Angeles, and is now leaving for a visit to Portland, Seattle and Spokane. The northern California district, which was for several years covered by a Sacramento jobber, has been handled since the first of the year direct from the San Francisco office, and Mr. Dennison finds the results much more satisfactory. W. E. Henry, of this office, recently returned from Sacramento. Mr. Dennison finds good talking machine men very scarce on the Coast.

The Dictaphone department is going ahead in great shape. Joseph Johnson is a new man in this department in Oakland, and Miss Mitchell has been added to the local force. An experienced Western man is expected shortly to take general charge of this department.

Kahn Bros. Place Large Order.

Kahn Bros., the Oakland department store, recently placed one of the largest orders ever received by the local Columbia office, and are prepared to get behind this line in a large way. The department is being moved from the third to the ground floor, where a number of rooms are being fitted up in the most modern style. W. C. Henry, son of W. E. Henry, the local manager, is taking charge of this department, having come from Los Angeles for the purpose.

C. J. Schmelzer, of the Schmelzer Arms Co., Victor distributor in Kansas City, was a recent visitor to Sherman, Clay & Co. in this city.

Andrew G. McCarthy, of Sherman, Clay & Co., made a visit to Los Angeles early in February, and is well pleased with the outlook for the Victor line there. For the whole territory, he says he has never seen anything like the way the business is growing.

A. R. Pommer, head of the Pacific Phonograph

Co., has been away for a few days on account of illness. At the local headquarters it is stated that they are as far behind in deliveries as they were in December, and can't tell when they will be able to meet the demand.

Kohler & Chase in Oakland.

Kohler & Chase have leased a new location in Oakland, to which they will move in about six weeks, at Fourteenth street near Clay, across the corner from Sherman, Clay & Co. An attractive talking machine department will be fitted up.

J. E. McCracken, the new head of the Edison Shop on Geary street, is too busy to talk these days. He is starting a very strong publicity campaign, and reports business fairly humming.

Shortage of Sonora Stock.

F. B. Travers, manager for the Sonora Phonograph Co., states that he is still badly hampered by lack of stock. He finds retail business very active, and is also doing a good distributive business, but is unable to make the new connections he would like to on account of deliveries. He hopes, however, to have plenty of stock within a couple of months.

Byron Mauzy is still expanding his talking machine department, and has engaged W. C. Hiatt to conduct this part of the business, Charles Mauzy still having general supervision of the talking machine and small goods departments.

A MULTIPLE DISC TALKING MACHINE.

Recent Invention Enables More Than One Disc to Be Played at Same Time.

Playing two or more talking machines at a time as a means for increasing sound volume has often been tried, but generally with poor success. Only a slight difference in the speeds or timing of the two discs results in throwing the melody into a jarring discord, for one record soon plays far ahead of the other, says Popular Mechanics.

To obviate these difficulties, and still secure the larger volume of sound resulting from the use of two or more records at the same time, a Paris inventor has devised a talking machine of a type different from the ordinary kind. All the records are attached to one vertical driving axis, and because of this mechanical connection must necessarily remain in unison throughout the playing of any given piece. Each disc is provided with its own needle and reproducer. All the sound goes into a common horn by means of suitable connecting arms properly pivoted at the large ends. In addition to greater volume, harmony effects may also be secured. This is done by using discs which individually play soprano, alto, bass parts, etc., the whole blending into one medley when run together on the machine.

EASTERN VICTOR SERVICE

IS WHAT SUCCESSFUL NEW ENGLAND VICTOR DEALERS USE

IT HELPS THEM TO BE SUCCESSFUL

It helps them to attract and hold customers by placing them in a position to give prompt service to their trade, to supply the machine or record wanted, when it is wanted, to make profits.

IT COSTS NO MORE THAN ORDINARY SERVICE

THE EASTERN TALKING MACHINE CO.

177 TREMONT STREET, BOSTON, MASS.

Largest Exclusive Victor Distributors in the East

THE PULLING TEST—THE STRENGTH IS THERE

THE STRONGEST ALBUM MADE AT ANYWHERE NEAR ITS LOW PRICE

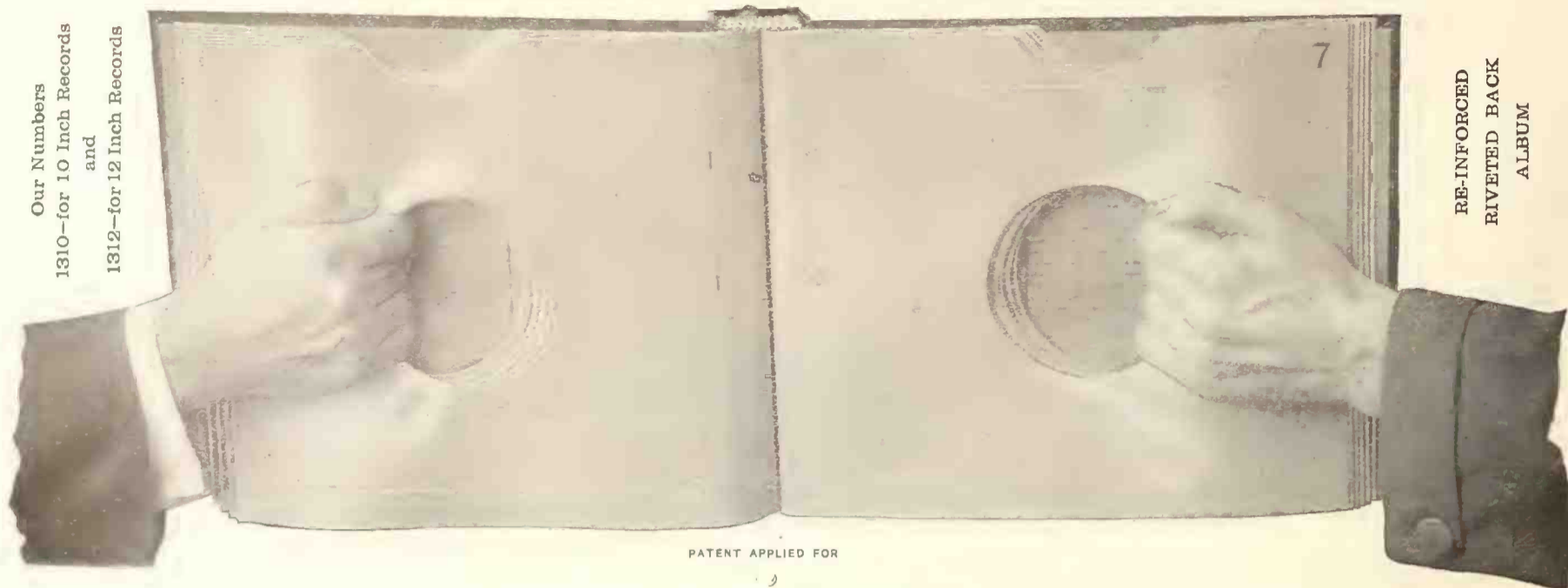

Strength at the Stress and Strain Point. Practically Unbreakable for Regular Usage.

THE WELL-KNOWN "NATIONAL" RECORD ALBUMS ARE ALWAYS THE LEADERS

THE ONLY CONVENIENT AND SAFE WAY TO PROTECT DISC RECORDS

These Albums will pay for themselves in a short time by preserving Records. When full the Albums are flat and even like books. They will fit in a library cabinet or book case, or they will lie flat on one another.

We manufacture disc Record Albums containing 12 pockets to fit the Victrola cabinets Nos. X and XI. We also make Albums containing 17 pockets. With the indexes they are a complete system for filing all disc Records.

For durability, finish and artistic design, our Albums have no equal. They are made in the most substantial manner by skilled workmen. We sell our superb Albums at big discounts to meet competition. Shall we quote prices?

THESE ALBUMS ARE THE BEST FOR VICTOR, COLUMBIA AND ALL OTHER DISC RECORDS

NATIONAL PUBLISHING CO., 239 S. AMERICAN ST., PHILADELPHIA, PA.

ACTIVITY IN INDIANAPOLIS.

Stewart Talking Machine Co. Makes Increases to Sales Staff—Some Big Deals Closed Recently—Series of Matinee Concerts at the Edison Shop Produce Excellent Results—Progress of Pathé Phonograph Shop.

(Special to The Talking Machine World.)

INDIANAPOLIS, IND., March 6.—General conditions in the talking machine trade in this city and vicinity are for the most part thoroughly satisfactory. There has naturally been some falling off of business since the holidays, but the fact that a machine shortage still exists has made any drop of business rather welcome temporarily than otherwise. Meanwhile, several of the local companies are making preparations for handling some greatly increased trade in the future.

In the offices of the Stewart Talking Machine Co. new desks and chairs have been added to accommodate the salesmen. The broad rooms in the big six-story building now present a most business-like and attractive appearance. Four years ago the business was conducted in one room and a small warehouse.

The Stewart sales manager is conducting operations for new accounts through a series of separately written letters to the trade. Although more time and money are needed to send such letters, it is believed the personal touch given each one is well

worth the investment. Favorable results have thus far attended this extension work, and many sales are now being covered.

The Columbia Graphophone Co. has boosted its Indianapolis business by a big contract A. W. Roos, local manager, closed with D. Sommers & Co., one of the largest furniture companies in Indiana.

D. Sommers & Co. are spending a large sum of money installing a beautiful department for the Columbia Grafonola, and it is apparent that the company will go after Columbia business on a big scale.

Mr. Roos spent several days in Chicago recently on official business. He reports that February business was good. In the Dictaphone department advantage is being taken of the local automobile show week to advertise with a well-arranged window display the Indiana automobile concerns and allied business that are using the Dictaphone in their offices.

At the Edison Shop an innovation has been started which promises to be a big drawing card. A series of matinee concerts has been arranged for in which singers of local reputation appear in duets with the Edison records. Mrs. Georgia G. Oakes, a soprano, appeared in the concert February 23, and Glenn O. Frierwood, a baritone, was the singer at the concert March 1. Mrs. Hazel Simmons Bowles, a soprano; Charles McCarthy, a

tenor; Mrs. Glenn O. Frierwood, a contralto, and Gaylor Yost, violinist, are the others who are scheduled to appear in the Edison Shop concert hall in the Wednesday afternoon concerts which will be held weekly during March. At the last concert more than three hundred persons attended. Invitation cards announcing the concerts are being mailed out to the public. Arch Olds, manager of the Edison Shop, explained that the appearance of local artists in connection with the Edison records serves to emphasize in a singular manner the human quality of the records and the machine.

At the Pathé Phonograph Store, which was opened recently at 10 East Washington street by Tobin Bros., business is beginning to move along nicely. Three Unit demonstrating booths have been installed and the store presents an attractive appearance. Several out-of-town dealers have been signed up by Tobin Bros. The Tobin Bros. expect to have their store completely fitted up and to be ready to sail in for business by the middle of March. They have already commenced an advertising campaign which promises to bring results.

TO HANDLE EDISONS EXCLUSIVELY.

E. E. Taylor & Co., of Olympia, Wash., who have conducted a piano business in that city for the past twenty-five years, recently disposed of their entire stock of pianos at special sale and made arrangements to handle the Edison phonographs and records exclusively at the old stand.

OCCUPYING NEW QUARTERS.

The Globe Decalcomanie Co. has transferred its offices from uptown in Jersey City to a larger and more commodious spot in the Lincoln Trust Building, 76 Montgomery street, Jersey City, where the head of the concern, J. R. Commerford will be pleased to welcome trade members.

Leroy Wedd and Fred C. Windmayer have opened a talking machine store in Atlanta, Ga., handling the Victor and Edison machines. Sheet music will also be carried.



METAL BACK ALBUMS

Give 300% More Service Than Any Other Album

THEY ARE PATENTED

No other Album like it has been or can be manufactured.

Send for Sample

NEW YORK ALBUM & CARD CO., 23 Lispenard St., New York



Victrola IV, \$15
Oak



Victrola VI, \$25
Oak

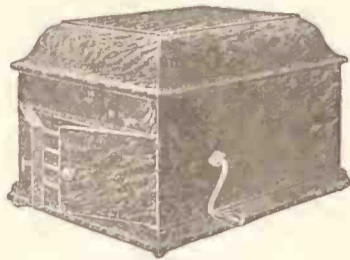

Victrola VIII, \$40
Oak



Victrola IX, \$50
Mahogany or oak

Victrola Supremacy



The enormous public demand for the Victrola, the unparalleled success of Victor dealers everywhere, unmistakably tell of Victrola Supremacy.

Victor Talking Machine Co., Camden, N. J., U. S. A.

Berliner Gramophone Co., Montreal, Canadian Distributors

Important warning. Victor Records can be safely and satisfactorily played only with *Victor Needles* or *Tungs-tone Stylus* on Victors or Victrolas. Victor Records cannot be safely played on machines with jeweled or other reproducing points.

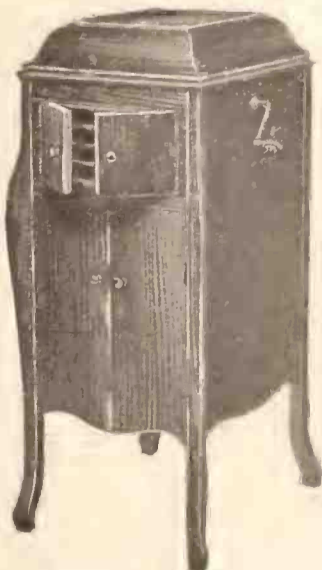

Victrola X, \$75
Mahogany or oak



Victrola XI, \$100
Mahogany or oak



Victrola XIV, \$150
Mahogany or oak

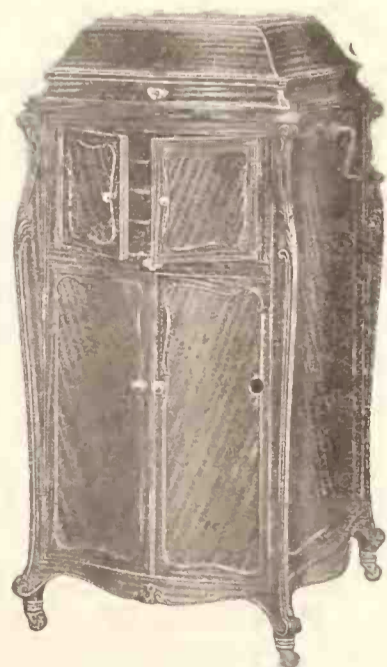

Victrola XVIII, \$300
Victrola XVIII, electric, \$350
Mahogany

The **TALKING**
For the makers & sellers of talking machines
MACHINE
WORLD

PUBLISHED BY THE ESTATE OF EDWARD LYMAN BILL
 (C. L. BILL, Executrix.)

J. B. SPILLANE, Editor

J. RAYMOND BILL, Associate Editor

AUGUST J. TIMPE, - - - - - Business Manager

Trade Representatives: GLAD HENDERSON, C. CHACE, L. E. BOWERS, B. BRITAIN
 WILSON, A. J. NICKLIN, AUGUST J. TIMPE, L. M. ROBINSON, WILSON D. BUSH.

Boston: JOHN H. WILSON, 824 Washington Street.

Chicago Office: E. P. VAN HARLINGEN, Consumers' Building, 220 South State Street.
 HENRY S. KINGWILL, Associate. Telephone, Wahash 5774.

London, Eng., Office: 2 Gresham Buildings, Basinghall St. W. LIONEL STURDY, Mgr.
 The Talking Machine World has regular correspondents located in all of the principal cities throughout America.

Published the 15th of every month at 373 Fourth Ave., New York.

SUBSCRIPTION (including postage): United States, Mexico, \$1.00 per Year; Canada, \$1.25; all other countries, \$1.75. Single copies, 20 cents.

ADVERTISEMENTS: \$4.50 per inch, single column, per insertion. On quarterly or yearly contracts a special discount is allowed. Advertising pages, \$125.00.

REMITTANCES should be made payable to the Estate of Edward Lyman Bill by check or Post Office Money Order.

NOTICE TO ADVERTISERS.—Advertising copy should reach this office by the first of each month. By following this rule clients will greatly facilitate work at the publication headquarters.

Long Distance Telephones—Numbers 5982-5983 Madison Sq.
Cable Address: "Elbill," New York.

NEW YORK, MARCH 15, 1916.

THE first month of spring shows a most optimistic spirit regarding business conditions prevailing in talking machine circles throughout the country. The activity in trade which started the closing months of last year has continued uninterruptedly, and, judging from reports reaching The World from various sections, it will quicken as the year grows older.

Not in many years has labor been so universally employed at splendidly remunerative wages as at the present time, and it should be understood that the wage earners of this country are tremendous purchasers of talking machines. At the high wages now prevailing they are able to satisfy their inclinations in various ways, and few instruments appeal to them so strongly for home entertaining purposes as the talking machine.

The demand among the working classes is not emphasized so much in the large establishments as in the smaller stores in the manufacturing sections where dealers have been compelled to keep open at late hours to cater to the demands of working people who desire to purchase talking machines and records.

This is a gratifying condition, and with the excellent prospects which now prevail in this industry it is probable that the output for the present year will exceed that of any year since the industry was launched.

The fundamental policy of price standardization and price stability which have been the dominating influences in the talking machine trade must be jealously guarded and strongly maintained to the end that business advance and business security be insured. Meanwhile there can be no resting on laurels won on the part of manufacturer, distributor or dealer; each has his work cut out for him. Success can only be won by straightforward, sincere application and effort. There must ever be a constant climb toward the top and no resting by the wayside.

THE development of the talking machine industry has been marvelous. There has been an enthusiasm and a go-aheadness on the part of everyone interested that has been contagious, but it must be remembered that the foundation of its progress has been built upon the price standardization idea which must be supported and adhered to if the business is to continue developing along its present successful lines.

There is good money for the man who enters the talking machine business; but it requires effort, study and concentration to produce the right kind of results. It is necessary in all other

trades—why should it not be in the talking machine business? Every business organization—no matter how large or how small—must be resolved to a comprehensive basis in order that success may be attained.

There are many things to learn about talking machines, and the man who "knows it all" will find on careful investigation much which he has left out when considering the business from a narrow viewpoint. This applies not only to a great many dealers, but to salesmanship—one of the most important branches of the industry. A broad knowledge of selling methods is as essential to the proprietor in his work of organization as to the individual salesman in his work of developing business. As competition becomes keener the sales end of the talking machine business becomes vitally important. It entails a more detailed knowledge of the technical end of the business—in other words, the ability to answer successfully every inquiry or argument presented by a prospective purchaser.

THE retail talking machine business has now reached a point where those who have been connected with it since its inception can join with business men in other lines in talking of the "good old days," for the business is changing. Conditions at present are radically different from those that existed even three or four years ago.

The development of the industry has brought forth a demand for a newer, and, one might say, a higher type, of salesmanship. The carrying of the record catalog in the mind and the ability to operate a machine does not permit the modern retailer to rank as a modern salesman. Competition in the talking machine field has reached a point where more or less active knowledge of construction and mechanical operation is required in dealing with the public.

The salesman handling the old-established and standard machines and records has back of him that powerful asset, prestige—a prestige that is held and developed further through the medium of millions of dollars spent annually in advertising. But he must be prepared, should occasion require it, to prove without a doubt that the prestige is deserved; that the value of the machines and records is not wrapped up entirely in advertising.

To the uninitiated one talking machine is much like another, and with the flood of machines now on the market it is necessary that the prospective purchaser have explained to him intelligently the difference between the various models and the reasons for the higher prices. At the present time there are to be found so-called salesmen who are actually unable to tell the customers what the real difference is between a \$50 and \$200 model of one of the leading makes which warrants the difference in price.

IT is a tribute to the great importance of and the great interest in the talking machine that there exists a desire for more expert knowledge on the part of the public. One prominent New York concern has for years utilized young women for the selling of machines and records, and for the most part their work was satisfactory, for the machines were sold largely by demonstration, and sales women were engaged for their ability to memorize the record lists. Under present-day conditions, however, the company has been compelled to utilize men for the selling of machines and train them adequately for that purpose, while the girls who have been retained have been instructed to confine themselves solely to record sales.

In years past a talking machine buyer for the most part contented himself with an inspection of the general outline of the machine and its playing qualities, and apparently had full confidence in the mechanical construction, and the guarantee of the manufacturer back of it. At present, however, there are many people who have purchased nondescript machines, equipped with weak or noisy motors of cheap construction, sound boxes and metal parts built with price as the first consideration, and as a result have become suspicious. They heard something of one spring, two-spring and three-spring motors, worm gear and cog-drive motors, mica and composition, sound boxes, universal tone-arms and a score of other details. With this imperfect knowledge the purchaser approaches the machine salesman in a "show me" mood, and the latter is called upon to display some real knowledge of the machine he is selling.

Tone is something that can be demonstrated to the satisfaction

of the purchaser, that may be explained and praised much as the salesman wishes, for to the average person—tone in a talking machine means that it sounds pleasantly and that there is an intangible something that makes it so. Metal and wood construction must be explained by facts and hence the demand for the salesman that "knows his business."

THAT talking machine men are realizing the dignity and importance of the business is evident from the fact that every week we are advised of some progressive firm having its ware-rooms rearranged, and also in every instance the fact is mentioned that separate rooms have been arranged and specially decorated for the purpose of better displaying the various lines of instruments handled. Even in the smaller towns dealers realize that the best results are obtained in a business way when a machine can be tested, and its good points brought out when it is displayed in a separate room away from general stock.

The sound-proof showroom is not exactly an innovation, but rather an evolution following the growing tendency to place the talking machine business on a higher plane rather than looking upon it as a purely commercial proposition. Yet if we consider the matter in a purely commercial light the benefit accruing from the adoption of most improved means for displaying talking machines and bringing their merits to the attention of the buying public through the medium of attractively arranged display rooms will result in larger sales and sufficiently increased profits to pay the cost in a short time of the installation of the most modern wareroom furnishings.

IN a statement issued recently, Louis F. Geissler, general manager of the Victor Talking Machine Co., Camden, N. J., gives some figures which tell of the enormous business transacted by that corporation during 1915. He said:

"We are thankful for an increase in our business over any preceding year of 38½ per cent., and that increase, on an already large business, is indeed remarkable. Our investments during 1915 in factory extensions, buildings and machinery, amounted to \$2,650,000, and those contemplated for 1916 will total a very large sum. Our capacity is being steadily and healthfully increased. However, it is our purpose, by advertising and other energetic methods, to keep the demand as far ahead of the supply in the future as has been the case in the past. Upon thought, dealers must agree that however annoying this condition has been, it is a most desirable one and we shall be fortunate to perpetuate it."

After complimenting the dealers on the energetic presentation of their wares, he remarked: "The business outlook for 1916 is glowing with promise; our country was never before, and, on account of world conditions, may never again be in so prosperous a money-making condition for the merchant as it will be during this year." Optimism that is built on a sound foundation.

THE Stevens bill has won the support of progressive manufacturers throughout the country who contend that the maintenance of the retail price is a necessary and legitimate business principle, that it means a benefit to all and works injury to none. The manufacturer who produces a standard article and gives it a trade-mark, or trade name, who spends his money to make that name mean quality in the public mind, should have the right to be protected after he has made that individual name valuable, for it is his property and his alone.

It is a symbol to the public of a certain quality of goods, and the character of the concern that makes them. Any practice therefore that injures the article in the public mind and damages the reputation of the firm is as unfair as the theft of a trade-mark itself. The manufacturer of such an article must put real value into his product; he must make the public want it. He individualizes it and gives it a name to be known by. He must establish a general market, advertise the merits and prices of his goods; he must convince the public that it is worth the price asked, and persuade the people to go to a store and pay the price.

But after the value and quality of this article has been emphasized publicly, and a demand created from the public, the price cutter steps in and gets busy. He takes this widely known article and reduces its price, not for the purpose of selling more of them, but rather merely to attract customers on the strength of a bargain price so that he may sell other products at a greater profit than the standard price goods.

Then other dealers are forced to meet this cut price, hence price demoralization. As Congressman M. Clyde Kelly, of Pennsylvania, said some time since: "Such unfair competition is as bad as outright theft of trade-marks and brands and should be severely frowned upon by the law. It is a case of stealing a man's good name, which, as Shakespeare said, is worse than stealing his purse. The manufacturer's name must mean value or he cannot build a permanently paying business. That value is an asset as valuable as his plant and merchandise. I contend that he has a right to ask and to receive protection from those who would rob him of his value. That protection can only come through the right to maintain a uniform selling price to the buyers of his product."

Speaking further upon how uniform selling prices will benefit the retailer, he said: "Price maintenance does not mean less competition between retailers, it means less unfair competition. There is a competition in the quality of goods and in service just as much as in price. Retailers who sell the same goods from the same factories should not compete in prices. The competition should be between goods of the same class made in other factories.

"That puts the competition on a fair basis, on price, quality and service instead of solely on ability to stand losses until a competitor is driven out of business. It gives the retailer the reward of enterprise, efficiency and honesty, instead of forcing him to descend to the trickery of trade pirates or go out of business."

P
E
A
R
S
A
L
L
S
E
R
V
I
C
E

"BUY your Victor goods in New York" for this city is the centre of the universe. Everything that can work to our advantage is offered by New York. New York is the home of Pearsall Service, located conveniently for shipping and co-operation.

Use logic in your buying. It will help you to secure either machines or records—promptly and quickly. Pearsall Service spells two words—quickness and completeness.

Silas E. Pearsall Co.

18 West 46th St., near 5th Ave.

New York, N. Y.

PLAIN GLASS VS. FROSTED GLASS.

Plain Glass in Talking Machine Demonstration Rooms Seems to Be More Satisfactory Than Frosted—How a Dealer Lost a Sale.

Are your soundproof rooms enclosed with plain transparent glass or with a frosted or translucent glass? A dealer said that only once did he find the plain glass a disadvantage. On that occasion a "prospect" had been made a customer for an outfit and had got up from the chair he was sitting on to reach into his pocket for some money. As he stood up he turned around and by doing so brought into his range of vision another customer who had just entered another room. The latter proved to be a friend that he was pleased and surprised to see. He went to him and began chatting. The anxious salesman could see that the conversation was of the line in question and felt and saw, though he could not hear, that the second comer was advising the first one to alter his decision. Such proved to be the case, for he came and announced that he had changed his mind about buying, nor could the salesman close with him. He had decided to buy a second-hand instrument. The man who related the incident stated that it was the only occasion he had ever regretted the plain glass. Otherwise the plain glass was an advantage. A glance shows when the rooms are occupied. The plain glass also makes the pilfering of records more difficult. Cases have been known where a customer has come in with a grip for the purpose of carrying away stolen records. With one clerk waiting on several customers there is less a feeling of the customer being left alone.

BRING ON YOUR BASEBALL TEAMS.

In view of the spring training at the baseball headquarters in the South, it will interest the trade to know that the Sonora employes in New York are going to be on the diamond this summer with a team that will be "second" only to the Boston Red Sox. If there are any phonograph

houses which aspire for baseball honors they can communicate with this team.

DANCE FLOOR HELPS TRADE.

How L. L. Haight Helps to Interest Customers in His Victrola and Grafonola Lines.

(Special to The Talking Machine World.)

McGREGOR, IA., March 1.—One of the most enterprising merchants of this city is Lorin L. Haight, who has built up a splendid Victrola and



L. L. Haight's Dancing Floor.

Grafonola business in this section. The department is very attractively fitted up, and an excellent line of instruments is displayed. The latest evidence of his enterprise is the addition of a new dance floor, which has proved a tremendous attraction to purchasers as well as a splendid advertisement for his house. The photograph of this new dance floor is shown herewith.

REMOVE TO LARGER QUARTERS.

The Standard Gramophone Appliance Co., manufacturer of "Standard" record cleaners and other successful talking machine accessories, has moved from 173 Lafayette street to 237 Lafayette street, New York. In its new home the company occupies far more space than it did in the past, and these additional facilities will enable it to take care of its fast-increasing business.

FORMAL OPENING IN DALLAS, TEX.

Western Automatic Music Co. Features Edison and Columbia Lines in New Store.

(Special to The Talking Machine World.)

DALLAS, TEX., March 8.—The Western Automatic Music Co., whose occupancy of its new three-story building at 1604 Elm street, this city, was reported in The World last month, held the formal opening of the new salesrooms on February 29, and attracted the attention of a large number of local music lovers with an elaborate program of classic and popular music rendered by the Wur-litzer Unit Orchestra and the Edison and Columbia phonographs. The program was continuous from 4 to 10.30 p. m.

One of the features of the new building is the handsome quarters devoted to the display and sale of the Edison Diamond Disc phonographs and the Columbia graphophones. Complete lines of machines and records of both makes are handled, the entire first floor being given over to that branch of the business. Four demonstrating booths are provided, they being finished in pearl gray with artistic inlay. J. C. Brown is manager of the talking machine department.

TO CONTINUE ACKERMAN STORE.

Estate of Late Scranton Dealer Announces Appointment of New Manager.

(Special to The Talking Machine World.)

SCRANTON, PA., March 6.—The G. L. Ackerman Estate has announced that the talking machine business of the late G. L. Ackerman, conducted at 537 Linder street under the name of Ackerman & Co., will be continued under the management of Alfred V. Williams, an experienced man and formerly manager of the talking machine department of Stoehr & Fister from the time of its establishment.

John C. Davis, formerly secretary of the Bureau of Health, succeeds Mr. Williams as head of the Stoehr & Fister department.

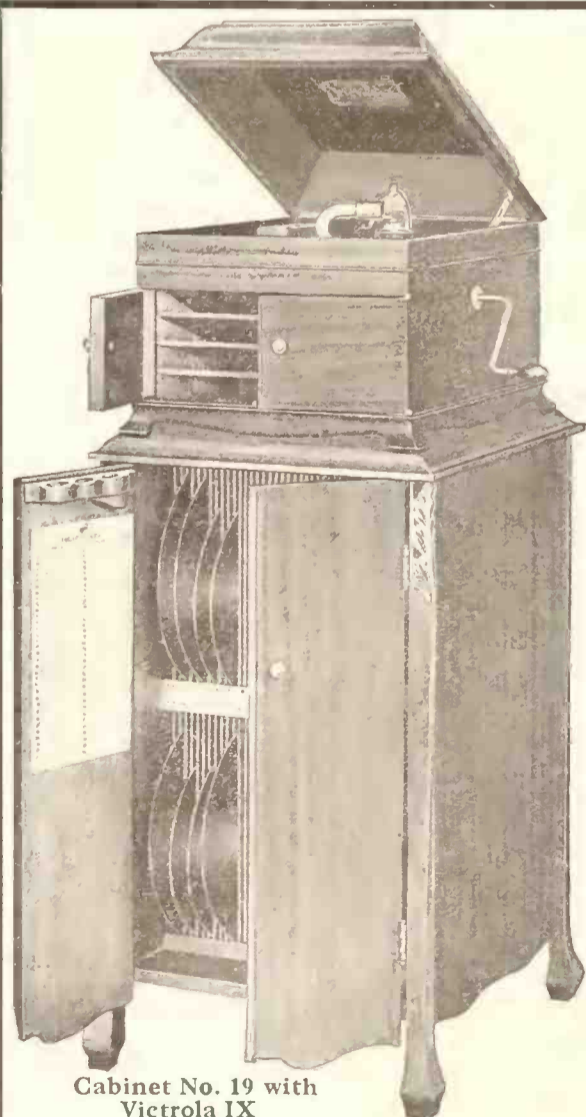

Cabinet No. 19 with Victrola IX

Originators of the Felt-Lined Cabinet
Avoid Inferior Imitations.

**Two Big Sellers
of the
Big Selling Line**

The two **SALTER FELT-LINED** Cabinets that lead today and have always been our biggest sellers are the two styles shown here.

The Victor Victrola IX

in combination with **Salter Cabinet No. 19** is always especially attractive to the buyer. In design and finish the cabinet is in perfect harmony with the machine. The felt-lined compartments afford ample protection for records. Built-up top holds machine firmly in place.

The Columbia "Favorite"

is handsomely supplemented by the **Salter Cabinet No. 112**, made especially for this machine, and is a perfect match in every way. Built-up top holds machine firmly in place.

**Salter Cabinets
are
Quality Cabinets**
Send for complete catalogs

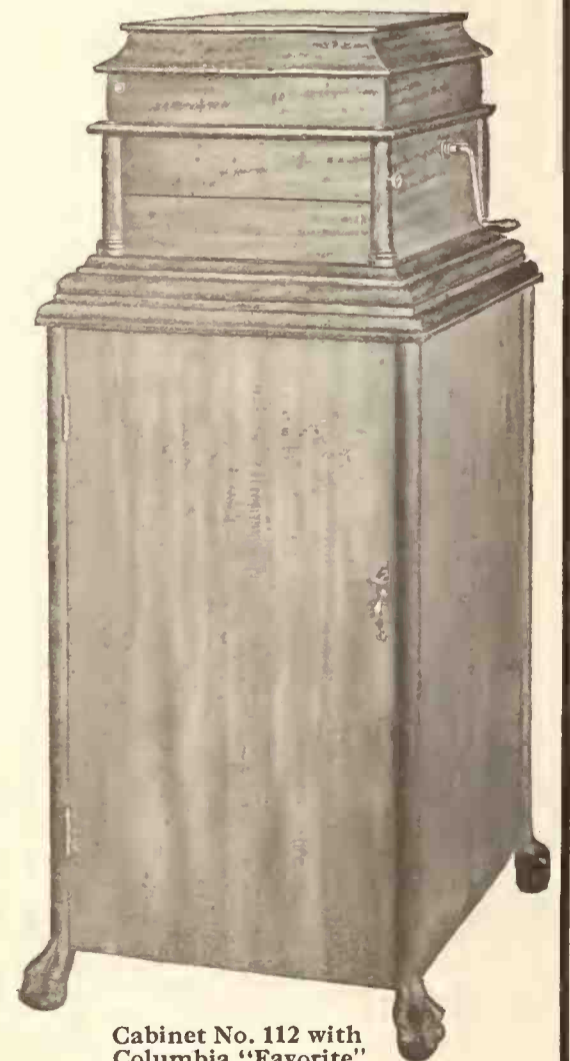

Cabinet No. 112 with Columbia "Favorite"

SALTER MFG. COMPANY.

337-39 N. Oakley Blvd.

John F. Mortensen, President

CHICAGO



Two new selections by Pablo Casals in the Columbia April list; also new selections by Oscar Seagle, Maggie Teyte, Eleanor Painter, Margaret Keyes; also many other recordings of various kinds for every occasion to meet the demand for music and entertainment. **No chance at all of missing a sale!**



(Write for "Music Money," a book "full of meat" for those dealers interested in quick and frequent turnover of capital.)

Columbia Graphophone Company
Woolworth Building, New York

COLUMBIA EXPERT IN TORONTO.

Mechanical Specialist Placed at Service of Dealers—Offers Valuable Advice—New Departments Opened Recently—Canadians Attend Edison Convention in New York.

(Special to The Talking Machine World.)

TORONTO, ONT., March 6.—The factory expert whose services were placed at the disposal of Columbia dealers in Ontario by the Music Supply Co., of this city, is meeting with a cordial reception. Many dealers have written his firm telling of the service it has been to them to have an expert go over their stock and to show the dealers or their assistants how to regulate or make adjustments.

To feature the higher grade types of Columbia Grafonolas to Toronto people, Gourlay, Winter & Leeming, Ltd., held a "Columbia Week." The window, specially treated with floral adornment, was devoted to the Columbia line exclusively.

Whaley & Royce Co., Ltd., which has the exclusive Canadian agency for Truetone needles, reports some nice business in that direction.

The Cecilian Co. in its retail warerooms is featuring the Sonora with splendid results.

I. Montagnes & Co., of Toronto, musical goods importers and Canadian phonograph distributors, have again leased larger premises on the third floor of the same building, where they are now located, running from Yonge street through to Victoria street. They are arranging offices, show-rooms and stockroom. Mr. Montagnes and Mr. Van Gilder are both pleased with results in Sonora phonograph business, which has been far in excess of their most liberal calculations.

R. P. Newbigging, head of the Hamilton, Ont., cabinet firm bearing his name, was a recent visitor to New York.

A complete Victrola department has been installed in the new music firm of A. Carey & Sons, 64 King street, West Hamilton, Ont., under the management of Bert Carey, who had been connected with the R. S. Williams & Sons Co., Ltd.

Arthur Mandy, manager of the Phonograph Shop, Ltd., Ottawa, recently had a successful window display featuring the Edison Blue Amberol record of "Little Gray Mother."

Operaphone records to retail at fifty cents are now being featured by the Canadian Phonograph Co. of Toronto, which has arranged for the wholesaling of these records in Canada.

The Nordheimer Piano and Music Co., Ltd., finds its Saturday afternoon Victrola recitals productive of splendid results. Each week sees the appearance of a local celebrity in addition to exploiting the many high-class artists of Victor fame.

Recent Canadian visitors to the annual convention of Edison jobbers, held in New York City at the Hotel Knickerbocker, included H. G. Stanton and G. Petch, of the R. S. Williams & Sons Co., Ltd., Toronto, Canadian Edison jobbers. At this conference Mr. Stanton was unanimously re-elected secretary of the Edison Disc Jobbers' Association.

The Arinola Manufacturing Co. of Canada, Ltd., has been incorporated in Toronto with the intention, we understand, of manufacturing in Canada the Arinola machine in its complete form.

Heintzman & Co., Ltd., are featuring with exceptional success Saturday afternoon Victrola recitals, in which the public seems to be intensely interested.

The Toy Products Co., of Canada, Toronto, has placed on the market a child's talking machine, "made in Canada."

JAMES BRATHERTON AS MANAGER.

(Special to The Talking Machine World.)

DETROIT, MICH., March 6.—James Bratherton, formerly with the Max Strasburg Co., this city, has been appointed manager of the wholesale and retail talking business of the Starr Piano Co. here. Mr. Bratherton has had wide experience in all branches of the trade and was for several years connected with the talking machine department of the John Wanamaker Co. in New York.

MME. FITZUI SIGNS WITH PATHE.

Famous Operatic Soprano, Lately Heard in "Goyescas," to Sing Exclusively for the Pathephone—News Creates Great Interest.

The Pathé Frères Phonograph Co., New York, closed another important artist contract recently when it completed arrangements whereby Mme.



Mme. Anna Fitzui.

Anna Fitzui, the popular operatic soprano, will record exclusively for the Pathé library.

In addition to her previous successes, Mme. Fitzui won the hearty praise of the critics recently when she created the role of "Rosario" in the premiere performance of the Spanish opera, "Goyescas," at the Metropolitan Opera House.

Anna Case, exclusive Edison artist, is sunning down on the beaches of St. Augustine and Palm Beach, Fla., after spending ten days in Bermuda recuperating from an operation for appendicitis.

Doehler Die Castings

are particularly adapted to the economical production of TONE ARMS and SOUND BOXES for Talking Machines.

Cast from permanent steel mould, no machining operation is necessary—all parts delivered ready for plating or enameling and assembling.

DOEHLER DIE CASTINGS are used with entire satisfaction by some of the most widely known makers of Talking Machines because "DOEHLER" product is economical, and "DOEHLER" service is dependable.

Send blue print or sample part for estimate.



DOEHLER DIE-CASTING CO.



BROOKLYN, N.Y.
TOLEDO, OHIO.



Producers of Die Castings in Aluminum, Zinc, Tin, and Lead Alloys
Also manufacturers of Die-Cast Babbitt Bearings and Babbitt-Lined Bronze Bearings

Any Artist Can Prove



ALICE VERLET
the Belgian coloratura soprano, testing Edison's
Re-Creation of her brilliant tones.



THOMAS CHALMERS
of the Boston Opera Company, matching his
living voice with Edison's Re-Creation of his
virile baritone.

Edison's Re-Creation of the voice of Anna Case or Arthur Middleton, of the Metropolitan, Thomas Chalmers, of the Boston Opera Company, Alice Verlet, the wonderful Belgian coloratura, or any other artist, is each as indistinguishable from the human original as one drop of water from another.

Noted critics of the leading musical centers of the country say so in their own words, in the columns of their own papers.

They recognize the distinct individuality, the oneness of the

New Edison Diamond Disc Phonograph

We have the evidence in black and white. For instance, of a recent Tone Test Recital, the New Haven (Conn.) *Register* said: "Many in the audience leaned forward to catch some difference in the voices. But there was none to catch. Miss Miller's own beautiful voice, in all its glowing, pulsing variations, was being matched tone for tone by the instrument. Edison had scored another triumph, it was the idealization of this great man's genius."

Critics of Boston, Philadelphia, New York, Cleveland, Milwaukee, St. Louis, Omaha, Denver, Toronto, San Francisco, Los Angeles, and many other cities say the same, only in different words.

Edison's Re-Creation

Neither artist, instrument nor record are especially selected for tone test recitals. Instruments and records are taken from stock and the artists are the same as are being heard almost every day on the operatic or concert stage. The secret is not in special combinations.

The secret is Thomas A. Edison's and his alone, wrung from nature by countless experiments and unstinted expenditure. To duplicate Re-Creation would require another Edison.

It required an Edison to wipe out the stigma that attached to "mechanical music" and produce in its place his

New Art— Music Re-Creation

The Instrument of Re-Creation, the New Edison Diamond Disc Phonograph offers you an opportunity you never had before the advent of the New Edison—to deal in a sound reproducing instrument that meets all the demands of the most cultured music lover.



ANNA CASE
of the Metropolitan, proving the perfection of
Edison's Re-Creation of her glorious voice.



ARTHUR MIDDLETON
of the Metropolitan, comparing his thrilling
basso with Edison's Re-Creation of it.

We will consider a few more high class dealers. Address

THOMAS A. EDISON, INC., 279 Lakeside Ave., Orange, N. J.

THE TRADE IN BOSTON AND NEW ENGLAND

JOHN H. WILSON, MANAGER, 324 WASHINGTON STREET, BOSTON, MASS.

(Special to The Talking Machine World.)

BOSTON, MASS., March 8.—Rate cutting is one of the things that the leading talking machine houses will not stand for, and because of rumors that have reached the home offices there have been investigations set on foot, with the result that in some cases dealers have been further denied the privileges of representing this or that concern. An instance was called to the attention of The World correspondent a few days ago. Here was a man with an upstairs location on one of the leading thoroughfares who had been doing a good business and had been looking forward to even more prosperous days. But it got noised around that he had not been living up strictly to his contract. It is understood that the charges were found to be true and he was further disqualified from being a dealer for this particular company. In another case a dealer was suspended for a period of time, but he is again in good standing.

Too Many Inactive Dealers.

Quite apart from the rate cutting habit and its demoralizing effect on the talking machine business it is felt in some quarters that there are altogether too many inactive dealers. These are not necessarily confined to the small, isolated places, but are to be found in even as large a city as Boston. These dealers are satisfied to do what to them is a reasonable business, but they do not push for business nor do they exhibit that enthusiasm that is an essential factor in building up a large establishment. These dealers do not watch their stock, either of machines or records, though this defect is more conspicuous along the latter lines. The result is that it too frequently happens that when a certain record is called for the dealer has not got it. Now, such companies as the Columbia, Edison and Victor want only on their lists dealers who are going to show enough enterprise to keep full lists of records, so that always they will be able to supply the demand. It is not impossible, therefore, that as time goes on there will be a gradual elimination of dealers and before a contract is made a prospective representative must give satisfactory assurance that he is going into the talking machine business for all it is worth and will push for new prospects by every legitimate means.

Manager Arthur Erisman, of the Columbia Graphophone Co., when asked about the foregoing and could he substantiate the arguments, said most emphatically that he could. He added that, so far as price cutting is concerned, there is not much

trouble with the large dealers, for they are disposed to abide by the strict rules of legitimate business. The process of elimination, he said, was largely in order that good dealers might become better dealers. The attitude maintained by the Columbia, he says, is in line with a gigantic campaign which the company is now entering upon; and to properly advertise itself the company must have the heartiest co-operation of all its dealers.

Big Increase in Columbia Business.

Mr. Erisman was pleased, in discussing conditions, to state that the business of his headquarters ran 113 per cent. in advance of the February business of a year ago. His office, now on the second floor of the Tremont street headquarters, is admirably adapted to his needs, far more so than the rather cramped quarters on the ground floor. There is a flood of daylight. The Dictaphone department is now located on the top floor of the building and the business is increasing rapidly.

Increase in Edison Diamond Disc Trade.

Manager F. H. Silliman, of the Pardee-Ellenberger Co., is highly optimistic these days over the growth of the Edison Diamond Disc business in his territory. Mr. Silliman was over at the jobbers' convention at Orange, N. J., recently. W. O. Pardee, head of the Pardee-Ellenberger Co., was in town a few days ago and expressed himself as well pleased over the prospects for the current year.

W. J. Fitzgerald Visits the South.

W. J. Fitzgerald, the wholesale manager of the Eastern Talking Machine Co., has been taking a much needed rest, and when he returned a few days ago from a fortnight's trip he looked in the best shape possible. He divided his time between Washington, Atlanta, Ga.; Jacksonville and St. Augustine, Fla.

Increased Facilities at Steinert's.

Manager Royer, of the Arch street quarters of the M. Steinert & Sons Co., one of the large Victor distributing centers of the city, makes the most satisfactory report of business that he has offered in a long time. The business is growing at a surprising rate, and the facilities for meeting the demands of patrons are now as complete as it is possible to make them. By a rearrangement of the floor much more space is now available and a passenger elevator to the record room and the offices on the second floor fills a long-felt want and is generously patronized.

To Feature the Pathé Line.

The Brooks Piano Co., which operates a large

retail piano room in the Continental building at the corner of Washington and Boylston streets, has become a Boston dealer for the Pathé line, and in a few days a special department devoted to demonstrating this machine will be ready for the public. William G. Brooks, son of the head of the firm, is an enthusiast over the Pathé Frères phonograph, and he will devote much of his time to exploiting its advantages.

Exhibiting the Columbia Electric.

By way of celebrating the advent of the new electrically-controlled Columbia graphophones Manager Arthur Erisman made an arrangement lately with the Edison Electric Illuminating Co. by which a large display of machines was made in the windows of the Edison Co. in Boylston street. Six different types of Columbia machines were shown, and the exhibit attracted considerable attention. But it was not Boston people alone who had the privilege of seeing such an exhibit, as Manager Erisman similarly had made arrangements for other exhibits in sixteen other stores throughout a large local area, so that by the time the period of exhibition had expired thousands of persons got a new idea of the value of operating a Columbia machine through the medium of electricity.

Miss Pearl Perrett has been added to the staff of the Columbia Graphophone Co. She is devoting her time to demonstrating Columbia outfits outside of the Tremont street establishment. Miss Perrett is a daughter of R. L. Perrett, a former manager of the Providence establishment of the Columbia Co.

Report Large Victor Trade.

The February business at the Victor headquarters at the Boylston street store of the Henry F. Miller Co. made a very creditable showing, and Manager Warren Batchelder is well pleased over the spring prospects. The line of records is a very complete one.

S. M. Revness, who as the representative of the Victor Co., has been in Boston for four or five weeks has shaken the dust of the Hub from off his feet and has hied himself to Worcester, where he will remain for a time.

Everybody is happy in the Victor department of the Oliver Ditson Co., where Manager Henry A. Winkelmann puts in six busy days each week. Mr. Winkelmann was one of the seventy-five men who enjoyed the dinner the other night of the Get-Together Club, made up of the members of the Oliver Ditson Co.

MORE is heard today regarding "quality" of phonograph music than ever before, and the Edison Diamond Disc Phonograph started this general conversation by reason of its admitted superiority. The Edison phonograph is also taken as the basis of ALL phonograph comparison and its tone is admitted to be best.

Aside from its tonal perfection, the artisticness of the cabinet designs enables the Edison Diamond Disc phonograph to harmonize with the most expensive interior furnishings of any home. We are "Exclusively Edison."

THE PARDEE-ELLENBERGER CO., Inc.
BOSTON, MASS. NEW HAVEN, CONN.

"E. D. D. P."

Window Displays Get Results.

In large measure due to artistic window displays of Edison and Columbia outfits, the business of the talking machine department of C. D. Osgood & Co., housefurnishers, has shown a marked increase lately. This department is most ably managed by Chester J. Sylvester, who is one of the most indefatigable workers in the business.

G. L. Parker Rearranges Department.

The talking machine department of George Lincoln Parker, in the Colonial Building, has been entirely rearranged so that now the Edison and Victor outfits are exhibited and demonstrated to far better advantage than formerly. Business continues good with the house.

Howard Shartle, of the Victor forces, has been in town interesting Victor dealers in the record accounting system, which already has been adopted by several of the local dealers, and by which it is possible to know on the instant how a house stands on records. Mr. Shartle was in Boston a year or more ago on the same errand.

Edward Sherman Resigns.

Edward Sherman has resigned from Chickering & Sons' house, where for a time he was connected with the Victor and Edison departments of the business. Mr. Sherman has decided to go into business with his father in another city.

Afternoon Teas Secure Results.

The afternoon teas inaugurated at the C. C. Harvey Co.'s Boylston street establishment are proving quite an innovation, and there are one or two women, good customers, too, who may be seen there quite regularly. Manager Francis T. White has an attractive young woman to dispense refreshments, in which the handsomest china and the most unique silver play a conspicuous and effective part.

Secures the Edison Diamond Disc Line.

Arthur W. Chamberlain, manager of the talking machine department of the Iver Johnson Sporting Goods Co., at 155 Washington street, has added the Edison Diamond Disc machines to his large equipment. He is about to rearrange the fourth floor, which is entirely given over to talking machines, so that there may be several more demonstration booths.

Two visitors to the local trade lately have been F. K. Dolbeer, the credit manager for the Victor Co., and George D. Ornstein, sales manager for the same concern.

NEW EDISON "AMBEROL" DEALERS.

Thomas A. Edison, Inc., Orange, N. J., recently issued a list of some of the new "Amberol" dealers who have taken on the Edison line during the past few weeks. This list reads as follows: Am-

berol line only—Austin's Pharmacy, Tupper Lake, N. Y.; Grenfell Milling & Elevator Co., Summerberry, Sask., Canada; W. R. Rea, Watson, Sask., Canada; W. M. Thomas, Bowden, N. D.; E. T. Hardham, Oak River, Man., Canada; H. B. Wiebe, Altoona, Man., Canada; W. J. Van Doren, Goodwater, Sask., Canada. Amberola and disc—Kingsport Stores, Inc., Kingsport, Tenn.; E. B. Pohle, Dexter, Ia.; Stephen's Art Store, Quaker City, O.; Veith & Dorn, West New York, N. J.; Smith's Music Store, Parkersburg, W. Va.; The Edison Shop, Pardee-Ellenberger, New Haven, Conn.; Elmer Johnston, Baraboo, Wis.

TALKER NEEDLES SENT BY AERO.

A dispatch from the official press representative with the army attempting to relieve the British forces surrounded at Kut-el-Amara to the London papers says:

"Cheery messages come from General Townshend (commanding the forces in Kut-el-Amara). He is sowing vegetable seeds and has asked for talking machine needles. These and other light requirements have been dropped into his camp from an aeroplane. He reports that he has sufficient supplies for a long period."

Quick Service for Victor Dealers

There's no lost motion in our organization—no red tape methods in our order department. Everybody here is ready and eager to help you to do business. When you want something in the Victor line right off, get in touch with us.

**Telephone to Steinert's
Oxford 1330**

Remember that we have the largest and most complete stock of Victor records in New England, and that it is yours to command.

M. Steinert & Sons Co.
35 ARCH STREET, BOSTON

If we have to steal the steel for Bagshaw Needles

Never in our history, since 1870, have steel conditions been in such shape. We have an immense stock, but Bagshaw needles are made from a steel that is made on our special order exclusively for needles and, notwithstanding our big orders, it is difficult to get. We make millions of needles a month, and are doing our utmost to maintain shipping schedules, but the future presents problems of a serious nature.

Better look over your stocks and book your orders this month.

W. H. BAGSHAW

Lowell, Mass.

Oldest and Largest Manufacturer
Established 1870

CENTURY

CENTURY

Why Century Cabinets Lead.

CENTURY CABINETS are "Built to Last," and are constructed of the best materials available. Quality is supreme, whether you purchase the No. 25 or the No. 200 design.

CENTURY CABINETS are built in a plant which is equipped to turn out only the highest grade work. The designs are prepared by artists—not mechanics, and the *prices are right*.

TWO OF OUR LEADERS

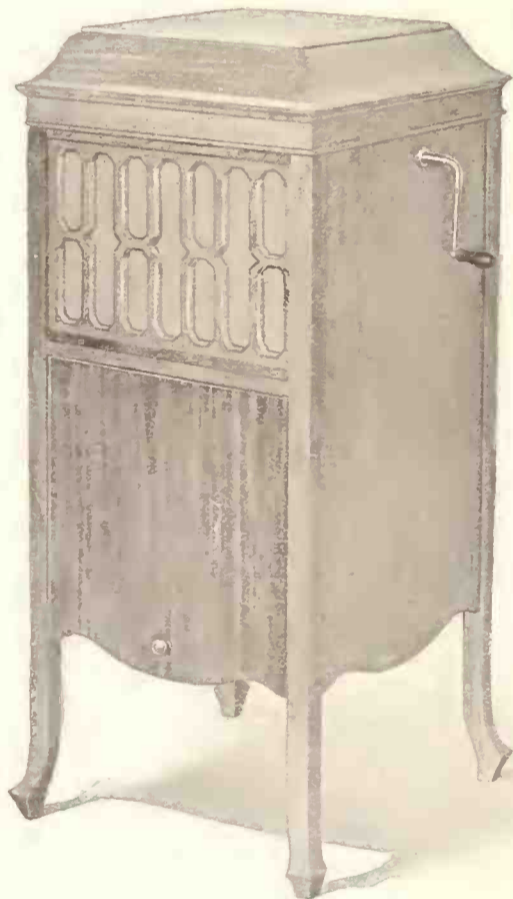

DESIGN No. 75

Made in Quartered Oak and Genuine Mahogany.
Dimen., 18 $\frac{3}{4}$ in. wide, 20 $\frac{1}{4}$ in. deep, 42 $\frac{1}{4}$ in. high.

Send for
Our
New
Catalog
and
Price List



DESIGN No. 200

Made in Quartered Oak, Genuine Mahogany and
Circassian Walnut.
Dimensions, 24 in. wide, 24 in. deep, 49 $\frac{1}{2}$ in. high.

We build Century Cabinets complete, and deliver them ready for the installation of motor sets. Quantity orders in any design handled promptly. Shipments made in packing cases that can be used for reshipping instruments.

We are also prepared to furnish Century Cabinets equipped with suitable Motors, Tone Arms and Sound Boxes, thus furnishing to our customers a complete line of phonographs tested and ready for use, and with our customer's label if desired.

CENTURY CABINET COMPANY

25 WEST 45th STREET, NEW YORK

CENTURY

CENTURY

The biggest and most beautiful feature of the Columbia advertisements that grace the pages of most of to-day's leading magazines and newspapers is the fact that the goods stand up through everything that is said there.



(Write for "Music Money," a book "full of meat" for those dealers interested in quick and frequent turnover of capital.)

Columbia Graphophone Company
Woolworth Building, New York

AN ARTISTIC DEPARTMENT

Is That Devoted to the Pathé Phonograph Line in the Lowry & Goebel Co. Store in Cincinnati—Homelike Atmosphere Prevails.

(Special to The Talking Machine World.)

CINCINNATI, O., March 6.—One of the most attractive talking machine departments in the local trade is the Pathé department in the Lowry &

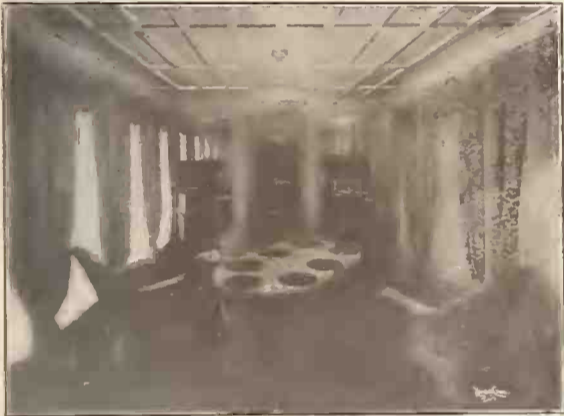

Lowry & Goebel Co.'s Pathé Department.

Goebel Co.'s store. This concern, which handles the Pathé line exclusively, is one of the leading furniture houses in this section of the State and has achieved the distinction of catering to a high-grade clientele which appreciates quality in merchandise as the paramount consideration.

There are four booths in the Pathé department, all of which are furnished artistically and comfortably. The color scheme of the booths is blue, lavender and antique ivory, and the beautiful design on the hand-blocked cretonnes is carried out in the other furnishings.

As a matter of fact, the Lowry & Goebel Pathé

department is considered one of the finest "talker" warerooms in this State, and the success which the company has achieved in this department may be attributed in a measure to the home-like, cheerful atmosphere of its booths.

VICTROLA FOR GREAT OUTFIELDER.

(Special to The Talking Machine World.)

WACO, TEX., March 7.—The Victrola department at the Sanger Bros. store was honored recently by a visit from Tris Speaker, a member of the world's champion "Boston Red Sox," and considered the greatest outfielder on the "diamond." Mr. Speaker is a native of Texas, and visited the Sanger Victrola department to select a Victrola for his mother at Hubbard, Tex. He chose a beautiful mahogany, gold-trimmed instrument, hand-carved, Louis XV. design, for which he gave a check for \$300. While making out this check Mr. Speaker stated that he could have secured another machine in the East, but he liked the Victrola so well and was so heartily in accord with the business methods of the Victor Talking Machine Co. and Sanger Bros., that he preferred to pay \$300 for a Victrola.

REPORTS AN INCREASED DEMAND.

"There has been a great demand for Emerson phonographs from dealers throughout the country," said Henry R. Stern, of the Jos. W. Stern & Co. Sales Corp., New York, distributor of these products. "Owing to the vastly increased production at the Emerson factory, with a consequent saving in cost, we have been able to reduce the wholesale price of these phonographs so that the dealer now has a good margin of profit to work on."

TIMELY RECORD PUBLICITY.

Special Letter Regarding St. Patrick's Day Music Sent to Machine Owners—An Active New Manager in Person of W. H. Haile.

(Special to The Talking Machine World.)

KANSAS CITY, Mo., March 6.—"As Long as the Shamrock Grows Green" is the first phrase of a unique circular letter sent out by the Schmelzer Arms Co. about three weeks before St. Patrick's Day. Believing that if other trades have special days when they may play up on some feature, Warren H. Haile, manager of the retail department of that store, had a large number of circulars printed telling of the Irish records in stock, and mailed out to over 1,000 machine owners on the mailing list. This was not in the form of a catalog, but was blocked as if it were an individual letter.

The body of the circular contains a short synopsis of the origin of Irish music, along with a list of the names of ten or twelve of the more popular Irish songs. An urgent invitation to call and hear these records or to have them sent out is embodied in the last paragraph of the letter. Mr. Haile is a new man with the Schmelzer people, having come to the Kansas City office from South Bend, Ind., where he was connected with George H. Wheelock & Co.

IF YOU BELIEVE IN MAINTAINING PRICES, WHICH ARE JUST TO THE PUBLIC AND JUST TO ALL, TELL YOUR CONGRESSMAN THAT YOU BELIEVE IN THE STEVENS BILL AND THAT YOU URGE ITS EARLY PASSAGE.

Building of the
Ditson Company
at Boston



DITSON

BOSTON
OLIVER DITSON CO.

NEW YORK
CHAS. H. DITSON & CO.

Building of the
Ditson Company
at New York

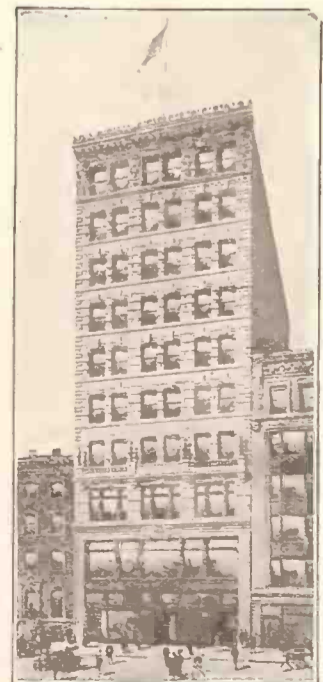

The name "Ditson" means music. Music means Ditson. Over 75 years of association with the retail trade of this country gives us a knowledge of conditions that is of help to you.

Ditson Victor Service stands foremost in the East. It is for the small dealer, particularly, that we desire most to help, but the small man of to-day soon grows, with intelligent help, to the big man of to-morrow. On our books are many dealers who formerly bought in lots of hundreds and now buy in thousands.

When you want real Service, get Ditson Service.

We furnish a complete line of musical instruments, from Accordeons to Zithers, and Books of Music and Sheet Music.

CASH PLENTIFUL IN MILWAUKEE.

Number of Sales Made on Cash Basis Steadily Increasing in that City—Shortage of Machines Still Felt Keenly—New Companies Enter Field—L. C. Parker as a Speaker—Larger Shipments Being Received.

(Special to The Talking Machine World.)

MILWAUKEE, Wis., March 8.—The talking machine business in Milwaukee and all over Wisconsin during the month of February showed continued activity, and a new high record for the present month is anticipated. General business has shown decided improvement, money is easier, and people are inclined to buy more freely. Milwaukee dealers say that the percentage of cash sales is increasing and that collections are decidedly better. James A. Fetterly, secretary of the retail division of the Merchants and Manufacturers' Association, says that collections in most lines of retail activity are above the normal point and that people are not only paying up their old accounts, but are buying much more freely. Judging from the orders which jobbers are receiving from dealers about the State, business with the average retailer is exceptionally active.

While Milwaukee jobbers in all the leading lines of machines are receiving larger shipments from their factories, the shortage of machines is still acute. Dealers are all being allotted a share of the machines which are arriving, but jobbers say that they could dispose of more than double the stock which they are receiving. Dealers are not only looking for machines to satisfy the present demands of their customers, but they are placing orders for stock intended for their summer and fall trade, for they realize that it is going to be a difficult proposition to secure enough machines at that time. Plenty of records are being received, and the new March records of the different companies are taking unusually well with the trade.

"Business is unusually good and we are unable to get enough Victrolas to meet the demands of our trade," said John H. Becker, manager of the Victrola and piano departments of Edward Schuster & Co. "The outlook is bright, considering the general improvement in all lines of business. February records sold very well, and the new March selections are creating much interest." Miss Adele Nero, assistant to Mr. Becker, has developed into one of the most successful young talking machine sales ladies in Milwaukee and has a fine sales record to her credit.

L. C. Parker, manager of the Victrola department of Gimbel Bros.' store, who has been developing quite a reputation as a speaker, especially along the lines of salesmanship, was one of the leading speakers on this subject at a recent meeting of the Alexander Hamilton Club, held at the Hotel Pfister. Mr. Parker gave an outline of methods by which a sales force produces results, and said:

"It is claimed that a man is worth \$2 a day from his collar down and as much more from his head up as he can earn by applying the knowledge that he possesses. He will achieve success in the degree



Victor Dealers

Those who relied upon us this season to supply their requirements of Victor merchandise are loudest in their praise of the excellent manner with which their orders were filled.

Were you one of these fortunate Victor dealers?

A timely New Year's suggestion. Try the service of the

BADGER TALKING MACHINE CO.

135 Second St.
MILWAUKEE, WIS.

Victor Distributors (Exclusive)

with which he makes use of his knowledge and ability."

The Elginola Talking Machine Corp. has been incorporated in Milwaukee, with a capital stock of \$10,000, by Frank Rose, Albert Salomon and S. R. Simon. It is understood that the new concern will engage in the manufacture and sale of talking machines.

The Flanner-Hafsoos Music House, 417 Broadway, has remodeled and enlarged its Edison department, and now has one of the finest departments of its kind among the Milwaukee piano houses. The company has given up half of its first floor quarters to the department and has arranged five attractive new booths. The house is meeting with a fine business in the Edison line.

The George H. Eichholz Co., 542 Twelfth street, handling the Victor and Edison lines, has been conducting a consistent campaign of street car advertising during the past year, and its attractive car advertisements have been an important factor in building up the successful trade which the firm now enjoys.

The suit brought some time ago in the Milwaukee Civil Court against William P. Gensch, head of the Gensch-Smith Co., conducting an exclusive Victrola shop at 730 Grand avenue, by Max Lepak, who sought damages of \$2,000 for remarks alleged to have been made by Mr. Gensch, was dismissed recently when Mr. Gensch proclaimed Lepak as an honest man.

The Columbia line has been installed in the main downtown store of Stumpf & Langhoff, Ltd., at Grand avenue and Second street. Mrs. C. L. McDonald is in charge of the department and is meeting with a fine business. The Columbia goods are being featured in attractive balcony quarters. The stock of machines and records for the new department was furnished by A. G. Kunde, 516 Grand avenue, Columbia jobber and retailer.

Despite the fact that more Columbia goods are now being shipped into Milwaukee, many more machines than are arriving could be disposed of, according to A. G. Kunde, jobber and retailer, 516 Grand avenue. Business has been so good since last fall that the brisk demand has kept the stock down to an unusually low point. Mrs. Kunde made two trips to Chicago recently and succeeded in securing several consignments of machines. Miss C. Gringes has joined the Kunde sales force.

The shipment of Edison machines and records to Milwaukee is increasing steadily, according to William A. Schmidt, manager of the Phonograph

Co. of Milwaukee, jobber in this territory for the Edison goods. Mr. Schmidt says that he is able to ship a few machines to all his dealers and that the shortage is not nearly as acute as it has been. Several new Edison dealers have been located at various points about Wisconsin. Mr. Buehlow has joined the sales force at the Edison Shop, the retail store conducted by the Phonograph Co.

DEATH OF THOS. R. WHITE, JR.

Thomas R. White, Jr., a vice-president and chairman of the board of directors of the American Graphophone Co., died Feb. 28 at Miami, Fla., where he had journeyed to regain his health after a siege of pneumonia. Mr. White had been con-



Thomas R. White, Jr.

nected with the American Graphophone Co. for many years and was one of the foremost figures in the remarkable growth and progress of this company in recent years. He had a broad grasp of every phase of the financial and industrial world and was keenly interested in the affairs of the American Graphophone Co. notwithstanding his many other activities. He was admired and esteemed by his associates, who are deeply affected by his sudden death.

THE PERFECTROLA Has Tone and Quality

A Satisfactory Musical Instrument

Models from \$10.00 to \$100.00

Cabinet finish and mechanical parts of the highest order insuring a minimum of trouble. Plays all lateral cut records—Our No. 100 is equipped with our new duplex reproducer, which plays all records without extra attachments—

Made by Milwaukee Talking Machine Mfg. Co.
Office and Factory, 416-418 4th St., Milwaukee



No. 30

Chicago Salesroom
The Perfectrola Co.
160 N. 5th Ave.

Kansas City Salesroom
Wm. E. King
Traders Building



No. 55

W Exclusive Territory W
The **AEOLIAN-VOCALION**



THE representation of the Aeolian-Vocalion is one of the most valuable franchises that the music industry has ever offered. The distinguished character of this new phonograph, the ease with which it sells, the superior clientele it attracts, the strength of the appeal its distinctive features make to the musically cultured as well as to others, and the magnificent publicity it is receiving—are vital factors no intelligent merchant fails to appreciate.

When to these considerations is added the fact that every representative is given exclusive territory, and that in this way he receives *full benefit* from all the business that can be done in his territory, the extraordinary value of Vocalion representation becomes apparent.

Everyone familiar with the phonograph business knows that the situation in this field is undergoing a radical change. The phonograph is becoming more and more popular, but the public is investigating and learning to discriminate.

Progressive merchants, who take advantage of the opportunity to secure representation of the Aeolian-Vocalion, are not only bringing additional business and prestige to their establishments for the present, but because of the protection afforded by the Aeolian exclusive territory policy, are building a permanent and profitable business for the future.

Territory is now being assigned for the representation of the Aeolian-Vocalion. Address the Aeolian-Vocalion Department

THE AEOLIAN COMPANY
AEOLIAN HALL, NEW YORK CITY

CHICAGO OFFICE: FINE ARTS BUILDING
MICHIGAN AVENUE

A complete display of all models of the Aeolian-Vocalion may be seen at this office



MODEL K
\$300

"—that afternoon I sang 'Annie Laurie'—not with my own voice, but with my own feeling!"

The AEOLIAN-VOCALION

"THE PHONOGRAPH OF RICHER TONE THAT YOU CAN PLAY"

"I HAD stopped for a moment in a music-ware room and on my journey to the door I paused.

"Someone was singing 'Annie Laurie' behind me, with such a wealth of beauty and expression that I turned. I was listening, not to a human being as I thought, but to a *new* phonograph that I had never heard before—the Aeolian-Vocalion.

"That was a wonderful experience. I was listening to a song whose simple melody is so familiar that naught but the most exquisite voice could stir one with it. And I was stirred to the very depths of my being. So rich, so full of color were the notes that sounded forth that I have never dreamed a phonograph could voice them.

"And so I asked to hear more, but with a smile, the demonstrator inquired—Would I not like to sing 'Annie Laurie' myself, first?

"And then a miracle of music happened. He handed me what he called the 'Graduola' which was attached to this wonderful phonograph. He showed me how, by pressing it, I could melt the tones away to the faintest whisper, or swell them forth to strong, full-throated power.

"So I, who never sang before, sang 'Annie Laurie.' Not with my own voice, *but with my own feeling*, and thrilled with the experience as I knew the artist himself must thrill. No music that I had ever listened to had given me a tithe of such exquisite pleasure.

"Did I buy that wonderful instrument? It's in my home today and I question if money could get it away from me if I could not replace it. With its

aid, I, a hitherto dumb musician, sing and play with the voices and the talents of the world's great artists."

The Aeolian-Vocalion is on exhibition and sale at the present only in a limited number of the leading music-stores. Catalog and address of the nearest store will be sent upon request; also particulars as to arrangements for hearing the Aeolian-Vocalion in localities where it is not represented. Address Dept D3.

PRICES FROM \$35 to \$2000

Conventional Styles, \$35 to \$75
without the Graduola

Conventional Styles, \$100 to \$350
with the Graduola

Art Styles, \$375 to \$2000
Moderate Monthly Payments

THE AEOLIAN COMPANY
AEOLIAN HALL NEW YORK

"Makers of the famous Pianola
and largest manufacturers of
musical instruments in the world"

Aeolian-Vocalion
Style II

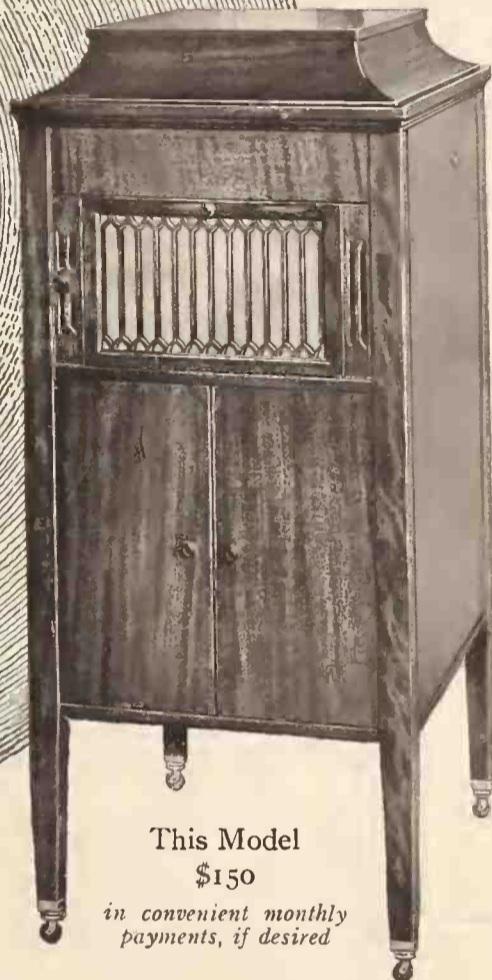

This Model
\$150

in convenient monthly
payments, if desired



"The Sweet, Old Song That Made Me a Musician"

I FIND that I'm a musician—must have been, in fact, all my life. Tho' as I have no voice and never learned to play any instrument, I've been a dumb one.

"Last Tuesday night, my wife and I were at the Jones's. Jones had a new purchase—a phonograph—and he obviously wanted to play it for us. We stood him off until after the last rubber, and then he was no longer to be denied. He simply went and got a record and started the machine.

"And then wife and I had the surprise of our lives. We never had cared very much for phonographs. Wife called them "screechy." Personally, I'm prejudiced against musical machines.

"But this phonograph was different. It wasn't screechy, and it wasn't a mere machine.

"'Oh! Don't you remember sweet Alice, Ben Bolt?'"

"With the first notes, I sat upright in my chair. A full-throated, rich human voice was singing the old, familiar words. It was beautiful. The very melody

seemed glorified by the inspiring tones that voiced it.

"'Come over here and sing this yourself!' said Jones.

"I went to him, not to sing, but to see what the slender tube terminating in a handle, which he had drawn from that wonderful phonograph, could be. It looked interesting.

"'Hold this in your hands!' said Jones. 'Move the handle in to make the music louder; draw it out to make it softer.' Then he started the record again.

"At first I hardly dared to move the little device in my hands. Presently, however, I gained confidence. As the notes swelled forth and softly died away in answer to my will, I became bolder. I began to feel the music.

"It was wonderful! Do you remember how in Du Mauriers' famous story, the hypnotist—Svengali—used Trilby's glorious voice to express his feeling?

"I was doing the same. I was using a splendid voice—I know not whose—to sing with. And as I sang the old, old song, and fairly trembled with the depth of emotion I was voicing, the fact that I was—must be—a natural musician dawned upon me. And with it came a glimpse of the glorious possibilities open to me by this great new phonograph.

"Violinist, singer, flutist, pianist, orchestra conductor—the whole musical genius of all the world was mine, not to hear merely, but to use for the expression of my own personality.

"This is the story of my metamorphosis—yesterday, musically dumb and voiceless; today, the most talented and versatile musician imagination could create.

An Invitation

Never can you appreciate the qualities of the Vocalion until you personally have heard it—played it. So we invite you to come to Aeolian Hall—to come, not to buy a phonograph, necessarily, but to inform yourself about the latest and greatest instrument of the phonographic type.

PRICES FROM \$35 to \$2000

Conventional Styles, \$35 to \$75
without the Graduola

Conventional Styles, \$100 to \$350
with the Graduola

Art Styles, \$375 to \$2000

Moderate Monthly Payments

THE AEOLIAN COMPANY
AEOLIAN HALL NEW YORK

"Makers of the famous Pianola
and largest manufacturers of
musical instruments in the world"

The Aeolian-Vocalion

"The Phonograph of Richer Tone, That You Can Play"

Copyright 1916 The Aeolian Co



Style E
RETAIL PRICE
\$50

The VOCALION Line Surpasses Any Other in Beauty and Completeness



THE distinguishing features of the Aeolian-Vocalion line, which is larger and more complete than that of any other phonograph upon the market, are—the good taste displayed in stock models, and the group of special Art cases which far surpass anything hitherto known in connection with the phonograph.

The stock models reflect the broad experience and ample artistic capacity of The Aeolian Company's department of design and case-making. Utmost care and technical skill are apparent in every detail. Simplicity and the repression characteristic of genuine art are evident in every design.

In the Art Styles the most unusual and artistic case effects are displayed. While some of these are original, others are based upon authoritative Period and other classic models.

No intelligent merchant need be reminded that there is a large clientele in every community that appreciates real beauty and art, and that this clientele constitutes a highly desirable addition to his trade.



The Vocalion is made in many unusual and effective Art Styles

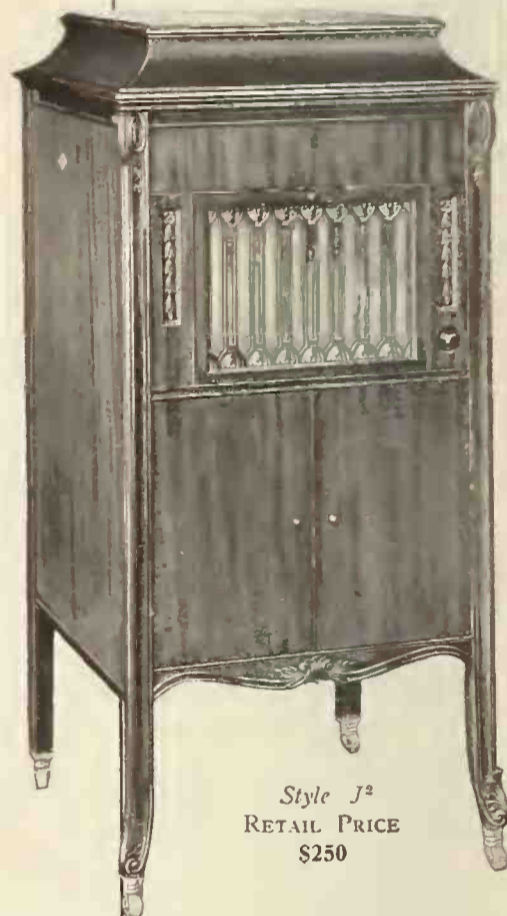

Style J²
RETAIL PRICE
\$250

Aeolian - Vocalions appeal to all classes. Their prices range from \$35 to \$2000 as follows: Conventional designs, \$35 to \$75 without the Graduola. \$100 to \$350 with Graduola. Art Styles from \$375 to \$2000 with Graduola and other important and exclusive features.



There is a lot of business to be had in the Foreign Records issued by the Columbia —business for to-day and business for beyond the day after to-morrow.



(Write for "Music Money," a book "full of meat" for those dealers interested in quick and frequent turnover of capital.)

Columbia Graphophone Company
Woolworth Building, New York

CINCINNATI DEALERS FIGHTING APPROVAL SYSTEM.

Dealers in that City Organize to Combat Practice—Supplies of Goods Coming Along with Satisfying Regularity—New Phonograph Shop Opened—Volker & Co. Take on the Knabe-Crystola—Heavy Sales of Aeolian-Vocalion—General Business Conditions.

(Special to The Talking Machine World.)

CINCINNATI, O., March 6.—One of the interesting developments of the past month was the resumption of a fairly normal supply of goods in most all lines and the ability of the trade, particularly the small dealer, to dispose of his stock almost as soon as it was placed on the floor. Consequently this means a healthy state of affairs.

"Sent on approval" may soon be relegated to the Middle Ages, so far as the Victor dealers about Cincinnati are concerned. Under the leadership of W. A. Davin, of the Cable Co., some of the Victor dealers have formed sort of an organization which includes the Rudolph Wurlitzer Co. One result of this movement has been the elimination on the part of the distributor from his advertisements of statements intimating that Victor goods could be obtained only from one store. The association in time expects to take in all dealers about Cincinnati, and its main object will be to put a stop to sending goods out on approval.

A new retail outlet has been secured by the Edison folks through the Phonograph Shop, which will be opened during the coming week by George Wabnitz, Jr., at 148 East Fourth street. Mr. Wabnitz will deal in Edison Diamond Disc phonographs and records. One of this assistants will be George Meek, who has been identified with the various phonographic lines for quite a number of years.

Volker & Co., Kansas City, have been appointed one of the distributors for the Knabe-Crystola phonograph, according to an announcement to-day by Ernest Knabe, of the Knabe Bros. Co. The latter, in speaking of the Crystola, said: "We are receiving twenty orders for every one we can fill."

The Starr Piano Co.'s factory at Richmond, Ind., is now able to supply its branch houses with a much larger record line.

C. L. Byars, manager of the Vocalion department of the Aeolian Co., reports over 100 per cent. increase in February's business of this year over that of last February. There has recently sprung up a marked increase in out-of-town inquiries concerning the Vocalion. A number of good sales were made by mail and most of them bought the larger instruments.

He reports that, in spite of the fact that he is not pressing the wholesale end of the business at all, yet a number of good dealers have been signed up. The dealers who have had the line several months are reordering with alacrity, and from all indications are finding the Vocalion business a big success.

One Vocalion dealer in central Ohio disposed of his entire initial order within three weeks and placed a substantial order for new instruments—closing his letter with the following remark: "Kindly make us a substantial shipment of catalogs and advertising matter. There seems to be no end of possibilities with the Vocalion line."

Manager Whelen, of the local Columbia store, says: "Business is great, orders are piling in and

there seems to be no let-up in the demand since the holidays. There is still a pronounced shortage on account of the fact that as fast as machines come in they are rushed out to the dealers needing them. The dealers throughout the territory realize the wonderful possibilities ahead of them for the coming year and are placing large orders even now for future delivery. There is no doubt in my mind but that great things are ahead of us and all Columbia dealers."

J. Greenfield, one of the best-known typewriter men in the country, has associated himself with the Dictaphone Co. with headquarters in Cincinnati at the local Columbia Graphophone Co. store.

AN INTERESTING ANALYSIS.

Statistics compiled by L. S. McCormick, sales manager of the Sonora Phonograph Corp., 57 Reade street, New York, since he undertook this office, which was announced in last month's World, show that one Sonora phonograph sells twenty more. This unit was arrived at after exhaustive study, both on the part of the Sonora representatives and the home offices. For one phonograph they could trace, they found that 200 machines were sold, but the average totals approximately twenty.

MUSIC FOR WOUNDED SOLDIERS.

Talking Machines and Records Being Sent to English and French Hospitals.

During the past few weeks twenty-one talking machines, 928 records, five mandolins and two guitars have been sent to the wounded soldiers of the allied armies by Miss May T. Moulton, who is working in conjunction with the Vacation War Relief, which was started by Miss Anne Morgan and her friends. Since the beginning of the present winter, Miss Moulton has been hard at work collecting talking machines and other musical instruments, and has supplied them to practically every battle front on which the English and French forces are fighting. Several base hospitals in Egypt, as well as scores of hospitals in France, have been supplied with musical instruments through this work. Appeals for contributions have been generously responded to, the charity forming a natural outlet for old records, of which the owners have tired. Landay Bros. are cleaning and packing the machines and records free of charge, and with each machine is packed a letter of cheer to the men and the officer in charge of them. Each talking machine sent over is accompanied by 700 needles and forty-eight records, and many letters of thanks have been received from the wounded soldiers, whose hours of pain have been made easier because of the music thus furnished to them. Miss Moulton asks that all who wish to help the cause along, either by donations of money, machines or records, send their contributions to her at 38 West Thirty-ninth street, New York City.

Save Freight Charges

The saving in freight charges (combined with better protection) is one reason over 75% of the cabinet machines are shipped in

ATLAS PACKING CASES

{(3-ply veneer—clear spruce cleats)}

Expert advice on style of packing and shipping costs.

Write for convincing facts

NELSON & HALL CO.

MONTGOMERY CENTER VERMONT

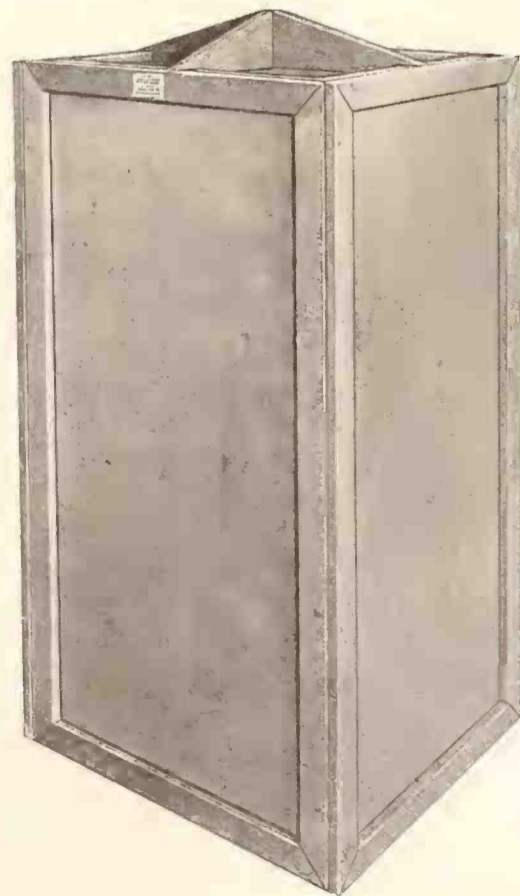

THE TRADE IN PHILADELPHIA AND LOCALITY

(Special to The Talking Machine World.)

PHILADELPHIA, PA., March 5.—Philadelphia has experienced a wonderful talking machine trade in the month of February, the net returns being very much larger than last year, and again limited to the amount of stock that it is possible to secure. But the percentage of loss in this respect was not so great as in January and the dealers are in a better frame of mind. Everything indicates that March is going to keep pace with the first two months of the year, and in fact go them better as it looks as if the factories were straining every effort to supply the dealers with what may be called at least a normal amount of stock.

The talking machine dealers are in excellent shape in Philadelphia at present, and two of our already large merchants are planning within the next month or so to move to very much larger quarters than they now occupy.

G. W. Barnhill to Visit Pacific Coast Cities.

G. W. Barnhill, of the Penn Phonograph Co., started for Florida the early part of this week to be gone a few weeks. He expects to make a tour of all the coast cities. John Miller, of the same firm, is at present in Atlantic City, where he has been for several weeks.

The Penn Co. report that their business is very good; much better than it was last year, and they believe that March is going to be very good, at least it has started off in that way. Their machines and records have been coming in in much larger quantities and they are at present filling a much larger per cent. of orders than they did earlier in the year.

Buehn Co. Reports Record Month.

The Louis Buehn Co. report that their business in February was greater than any previous month in the history of their business, with the exception of December 1915 and 1914, and that the outlook for the balance of this year is extremely bright. While machines are coming in to them with much better regularity, they are not yet in a position to supply machines as fast as they are ordered, and they note that the dealers who are getting the best service are those who have a constant order for them standing. They also note that there is still a shortage of some of the best selling records.

Death of Arthur Peterson.

Arthur Peterson, who covered Pennsylvania and New Jersey for the Buehn firm, died recently at

his home in Vineland, and was buried at Collingswood, N. J. He had been with the firm for about two years. They feel that they lost a very valuable man, as he thoroughly understood the talking machine business and was well liked by the trade in general. The Buehn firm have taken on a new salesman, E. P. Bliss, Jr. who will cover a part of Mr. Peterson's territory, as well as other sections. He was formerly employed in a similar capacity by the firm of Lyon & Healy, Chicago. Among the visitors to the Buehn firm the past week were J. J. Knies, of Mahanoy City; Mr. Gewehar, of the Gewehar Piano Co., of Wilmington, Del., and Mr. Lewall, of Catasauqua, Pa.

Applications for Columbia Agencies.

The Pennsylvania Talking Machine Co. has been

enjoying the general prosperity, a prosperity limited to what stock the Columbia Co. allows it. It is, at the present time, holding more applicants for agencies than ever before in the history of the business, orders and contracts that represent thousands of dollars' worth of business. Until more substantial shipments will come through, it has assumed as its policy to take the best of care of those it already has on its books, which it thinks is only the part of wisdom and fairness. February was a wonderful month with the Pennsylvania Co., showing a very substantial increase over last February, although the increase is insignificant in comparison to the unfilled orders. Mr. Eckhardt says the demand continues and will continue, from all indications, above anything that any one has anticipated. A. Thalmayer, who has been identified with the international record department of the Columbia Co., has been placed in charge of the foreign or international record department to succeed N. S. Haim, who resigned. It will make a particular feature of this branch of the business.

Doing a Big Dictaphone Business.

The Dictaphone Department of the Pennsylvania Co. reports that it has had another wonderful month, and the only reason for its not being a larger record breaker was that there were not enough goods to fill the orders. The company has had a great many orders for Dictaphones signed up merely awaiting the arrival of the goods. One of the pleasing features of the Dictaphone business is that it has had such a quantity of reorders. Among its largest installations during the month of February were the following: Whiting, Patterson Paper Co., paper manufacturer; Henry Hitner Sons Co., iron; H. K. Mulford, chemist; the Baldt Steel Co., steel; Campbell, Peacock & Kruger, cement; the Furness Withy Co., steamship agent, and A. T. Baker Co., plush manufacturer.

Plans for Great Business Show.

For years Philadelphia has attempted to have a business show, but with only partial success, but this year it will have a business efficiency show which promises to be of a very productive character, which will be conducted by Frank Tupper, and which will begin at the First Regiment Armory on March 13, to be continued until March 18. It will be one of the greatest exhibitions

(Continued on page 22.)

*Pen Your Victor Orders
to Penn*

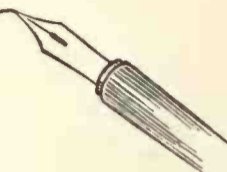

**V
I
C
T
O
R**

There are many reasons back of the broad statement above as to why Penn should fill your orders. One is, because Penn can do it, if anyone can. And that's one reason why you see no stock piled up around our storehouse, for every available machine and record goes OUT to our dealers. Put your trust in Penn. We'll work hard to please you.

Penn Phonograph Co., Philadelphia

1864—ESTABLISHED OVER HALF A CENTURY—1916

VICTOR DEALERS

Send your orders for Victor Records to

WEYMANN

for the best Victor Service in the East

We are now booking orders for Victrolas,
all types, for early deliveries.
May we serve you?

WEYMANN & SON, Inc.

VICTOR DISTRIBUTORS

1010 Chestnut Street

Philadelphia, Pa.

We Are Filling Record Orders Practically 100 Per Cent.

A loafing Southern darkey was offered 25c to do some work. He refused, saying: "Why should I work? I have 25c now."

SATISFACTION may come with the possession of "two bits" but we are never satisfied with the work we are doing towards making life easier and more profitable for the dealer.

Week in and week out, while we are working to furnish everything we can in both Victor machines and records, we are also striving to improve upon the methods of handling stock; of anticipating machine and record orders; of caring for the "short" orders; solving transportation problems, as well as the countless details that either make or break a service.

Our policy of "exclusively wholesale" leaves not the slightest thought on the part of any dealer but that our efforts are for HIS BENEFIT, and for his benefit alone. Buehn Service stands as a library of merchandise and post-graduate knowledge that can be secured almost at will.

One of your fellow dealers said: "Buehn Service is as near perfection as an expert organization can make it." You can prove this by submitting a list of records desired, and we want you to include in this selection some of the records that you may have tried to obtain elsewhere. This is a good test, and we know your order will be filled beyond your expectations.

To change the old saying a little: "The proof of the Service is in the filling."

The Louis Buehn Co.

Philadelphia's

Exclusive WHOLESALE

Victor Distributor



Record orders are now being better filled than for several months.

Shipments from the Victor Co. have made it possible for us to fill some orders as well as 90 per cent. Orders for Supplies and Repair parts filled promptly and correctly.

Test us with any size of order—small or large—so you can see that Buehn Victor Service means a co-operation that is modern in every characteristic.

We will guarantee a larger percentage than any other jobber.

THE TRADE IN PHILADELPHIA.

(Continued from page 20.)

this city has ever seen. The Tupper Brothers have given shows in New York, Boston and Chicago, and thoroughly understand their business. The Dictaphone Co. has taken a large double space, known as booth numbers 43 and 44. The latest models of the Dictaphones will be shown. The exhibit will be in charge of J. D. Westervelt.

The Edison Dictating Machine has also taken a large double space. Mr. Bostwick, of the Edison Co., will be here during the entire exhibition, and N. C. Durand, vice-president of the company, will be here all day of March 15.

The manager of the Edison Dictating Machine reports that January and February were the two biggest months it has ever had. Among some of its prominent installments in February were with the G. G. Clows firm, the Dodson Coal Co., R. G. Dun, the General Electric, the Philadelphia Electric, and the Parkesburg Iron Co.

Clarence Hopkins has left the employ of the Cunningham talking machine department, and he has been replaced by Martin Socklaugh.

The firm of H. A. Weymann & Son have had a most satisfactory February, although they still find themselves short of certain machines and some of the most popular of the records. Harry Weymann, who has just returned from a ten days' trip through the South, states that the demand upon them is still greater than the supply. They are not finding as much difficulty with their record department which has been at least a hundred per cent. better than last year. Their three representatives are on the road and are sending in some very substantial orders for both records and machines.

The firm of Blake & Burkart, the biggest handlers here of the Edison, are having their new store entirely repapered and repainted at the present time, and as soon as it is completed they expect to give a series of interesting concerts. They have been having a very gratifying business on the Edison machine, as they note have all the other firms handling it in this city.

FROM REAL ESTATE TO OPERA.

Thomas Chalmers Had Planned Business Career Before Realizing Value of Voice.

Thomas Chalmers, one of the popular members of the Boston Grand Opera Co., and who has also won much favor through the medium of the rec-



Thos. Chalmers.

ords he has made for Thomas A. Edison, Inc., started out on the sea of business as a real estate operator, and was doing fairly well when he discovered that he had a baritone voice and was advised by his friends to have it trained.

Mr. Chalmers went to Italy nine years ago, where he studied for several years under Lombardi, and four years ago came back to sing here. His success was immediate, and instead of selling real estate he is now buying it.

The singer is enthusiastic regarding Mr. Edison's accomplishments and delighted with the Diamond Disc recreations of his baritone voice.

CLOSED A BIG FEBRUARY BUSINESS.

(Special to The Talking Machine World.)

DETROIT, MICH., March 7.—H. C. Shea, sales manager of the Pathephone Co. of Detroit, 114 Farmer street, Pathé distributors, reports the closing of an excellent business in the month of February. A number of new accounts were opened during the course of the month, and the company, which was one of the first Pathé jobbers in the country, has made arrangements to carry a complete stock of Pathephones and Pathé disc records at all times.

Among the additions to the company's sales staff is Harry A. Russell, formerly connected with the American Phonograph Co., and well versed in all details of phonograph merchandising. Mr. Russell has already commenced work, and is extending real co-operation to the Pathé dealers in this territory.

EDISON PLANS FOR THE FUTURE.

Will Do Some Highly Shocking Things if He Lives Long Enough to Accomplish Them.

Thomas A. Edison, who recently celebrated his sixty-ninth birthday, prepared some years ago the schedule for his future life. Dyer and Martin, the authors of his authorized biography, "Edison: His Life and Inventions," quote him as saying: "From now until I am seventy-five years of age I expect to keep more or less busy with my regular work, not, however, working as many hours or as hard as I have in the past. At seventy-five I expect to wear loud waistcoats with fancy buttons; also gaiter tops; at eighty I expect to learn how to play bridge whist and talk foolishly to the ladies. At eighty-five I expect to wear a full-dress suit every evening at dinner, and at ninety—well, I never plan more than thirty years ahead."

M. J. Harrison, of Richmond, Ind., has been named a charter member of the International Phonograph Dealers' Association, which has its headquarters in New York City.



WAIT!

We Have a Few Surprises For You

They will make the "WONDER" phonograph even a more marvelous value than it is now.

Don't Commit Yourself

for the coming season until you have communicated with us and investigated. It will repay you.

Write for descriptive folder, advertising material and special dealers' proposition.

THE WONDER TALKING MACHINE CO.

113-119 Fourth Ave. at 12th St. New York

Telephones, Stuyvesant 1666, 1667, 1668

THE GREAT USED NEEDLE PROBLEM.

The Genius Who Devises Some Use for Worn-out Talking Machine Needles Will Be Crowned with Fame and Fortune—Perhaps.

Great excitement has been caused among the owners of talking machines in Greater New York over a controversy at present running in the New York Sun as to the best method of utilizing worn talking machine needles. The unknown who started the rumpus wrote to the paper a short time ago, and stated that thousands of persons who owned talking machines would be exceedingly interested in a method of turning worn needles into some useful purpose. As soon as his letter was published, the post-office had to add another carrier to the route in order to deliver the mass of answers sent in, each one containing a suggestion as to what to do with the needles.

One of the first suggestions received was to the effect that the needles should be given to glaziers, to be used instead of the triangular zinc brads generally used to keep panes of glass in window frames. This was answered by another genius, who wrote at length and on both sides of the paper, stating that the needles were absolutely useless as a substitute for glazier's brads, but that they should be driven into the heels of shoes, on the side where they wear down, thus preventing fallen arches, ingrowing nails and pigeon toes, at the same time affording the wearer a sort of caulk, similar to that used by humane drivers on snowy days, which would enable the needle-shod pedestrian to stride along the slipperiest of streets without skidding—a sort of non-skid shoe, so to speak.

A budding financier, scenting fortunes in the export trade, suggested a co-operative syndicate of talking machine owners, who would send their worn needles to a central point, whence they would be shipped to Africa and marketed there among the savages for tattooing purposes. A resident of Hensfoot Corners telegraphed in to state that he used his discarded needles to save his apple trees from caterpillars and bugs and things by first daubing a ring of sticky stuff around the tree-trunk, and then sticking the needles into the glutinous matter, butt end down, point end out and so close together that millions of insects, climbing after the fruit, committed suicide when trying to get over the stockade thus formed, the result being that the neighbors' children, who got all the apples one dark night, didn't find a single worm in any of them.

The controversy is still unsettled, and Manhattanites are sitting up nights pondering over the woful waste caused by the apparent uselessness of worn-out needles, and seeking to find some means of converting these worn "points of speech"

Are You Satisfied that the *Sound Box* on your Machine has a *Satisfactory Diaphragm*?

"CRYSTAL EDGE"

(The Edge is Clear as Crystal)

MICA

DIAPHRAGMS

Will Meet the Most Exacting Requirements

Can be furnished in any quantities

Only highest grade MICA used

Prompt deliveries assured—Write for samples and prices

JAMES FRAZEE, Manufacturer

Hudson Terminal Bldg.

30 Church Street, New York

into a profitable channel. But no matter what use may eventually be found for used needles, one thing is certain, after having once been used to play a record they should not be used over again for the same purpose.

ISSUE NEW PRICE LIST.

Sales Division of the Columbia Co. Announces New Prices for Columbia Electric Grafonolas—Names of Machines Are Also Changed.

The sales division of the Columbia Graphophone Co., New York, has announced a new price list for Columbia electric Grafonolas. This list also changes the designations of these machines, as, in accord with the new policy of naming Grafonolas, the price of the machine constitutes its name.

The new price and name list, with the former designations, is as follows: Style 150E is changed to Style 125E, price \$125; Style 160E is now 135E, price \$135; Style 200E is now Style 175E, price \$175; Style 250E is now changed to Style 225E, price \$225.

The new list provides for an increase of only \$25 from the prices of the regular Grafonolas to give the purchaser an electric Grafonola. The Columbia electrics have achieved country-wide success, and the new prices will doubtless act as a new impetus to their sale and add materially to their popularity.

GRAVEURE WITH COLUMBIA CO.

Noted Belgian Baritone to Make Records Exclusively for This Company.

The Columbia Graphophone Co., New York, announced recently the consummation of arrangements whereby Louis Graveure, a Belgian baritone of international prominence, will record exclusively for the Columbia record library. Mr. Graveure's first records will be issued shortly, and the prestige which he has attained in musical circles augurs well for the sale of his records.

LEAVE FOR EUROPE.

Louis Sterling, general manager of the European interests of the Columbia Graphophone Co., and Arthur Brooks, head of the English recording laboratory, sailed for England last week on the steamer "Nieuw Amsterdam" after an extended visit to this country.

GEN. PERSHING ATTENDS TONE TEST.

(Special to The Talking Machine World.)

EL PASO, TEX., March 6.—Elizabeth Spencer, concert soprano, and Harold Lyman, flutist, from the Edison laboratories at Orange, N. J., recently appeared in an Edison tone test recital in this city. Among the delighted attendants were several United States Army officers on duty along the border. Gen. John J. Pershing was one of these.

AT YOUR SERVICE—WITH GOOD SERVICE

ARE YOU OBTAINING ALL THE VICTOR GOODS YOU NEED?

CAN WE HELP YOU?

MAKE SURE THAT WE ARE ON YOUR LIST OF DISTRIBUTORS

THE ALL YEAR ROUND DEALER IS THE ONE WHO ALWAYS GETS THE PREFERENCE WHEN GOODS ARE SHORT

BE ONE OF OUR "ALL YEAR ROUND" DEALERS

AMERICAN TALKING MACHINE CO.

368 LIVINGSTON STREET

BROOKLYN, N. Y.

VICTOR DISTRIBUTORS

REED ARTISTRY IN THE MAKING OF TALKING MACHINES.

Some Remarkably Artistic Creations Turned Out by Dr. Alva Jones, the Noted Technician of Philadelphia—The Principal Features of These Creations Interestingly Described.

The three photographs illustrated herein give a vivid idea of the beauty of reed artistry in the making of talking machines, these being the creation of Dr. Alva D. Jones, a noted technician, with offices at 601 Witherspoon Building and laboratories and experimental station at 1218 Filbert street, Philadelphia, Pa., and who, it will be remembered, is the inventor of the famous Jones Rubber-tone reproducer. In addition to being an M.D., he also has the titles of E.E. and M.E., and is famous as a consulting engineer.

From these photographs one can see the various



Dr. A. D. Jones.

We must understand that the talking machine is strictly a secondary consideration, and when we listen to it reproduce an original instrument we never for a moment think of anything but the original and its characteristics, which cannot be obtained if the reproducing device has an individual tone, and in my experience, which has been vast in this line, the talking machine and sound reproducing instrument per se, that is, the sound box, should be made of such material and constructed in such a manner as to be absolutely free from an individual tone in itself, yet that part that must preserve and amplify the original sound must be sufficiently dense to take care of the most delicate shades of music.

"Referring again to my reed cabinet, I wish to say that by reason of it being constructed in sections, although it is made by hand, it will be within the reach of the most modest purchaser, as a great

be changed at will. If the reed is to be left in its natural state, a brush, soap and water makes it look as good as new at any time. It is not subject to being scratched, as the highly polished wood or board cabinets. On account of it being made of rattan, it is practically indestructible. A machine the size of the one shown in the photograph would only weigh twenty or twenty-five pounds complete. The special sound reproducer belonging to this machine is most wonderful, although any standard type of sound reproducing machinery may be fitted into it."

PEERLESS PHONOGRAPH CO. SOLD.

Ricca & Son Purchase Concern Which Was Started by Ben H. Janssen.

The Peerless Phonograph Co., of this city, was recently purchased by Ricca & Son. The purchase included the stock and good will of the company, which was formed originally by Ben H. Janssen to do a jobbing business in the Pathé Pathephone and Pathé records. The new owners of the com-

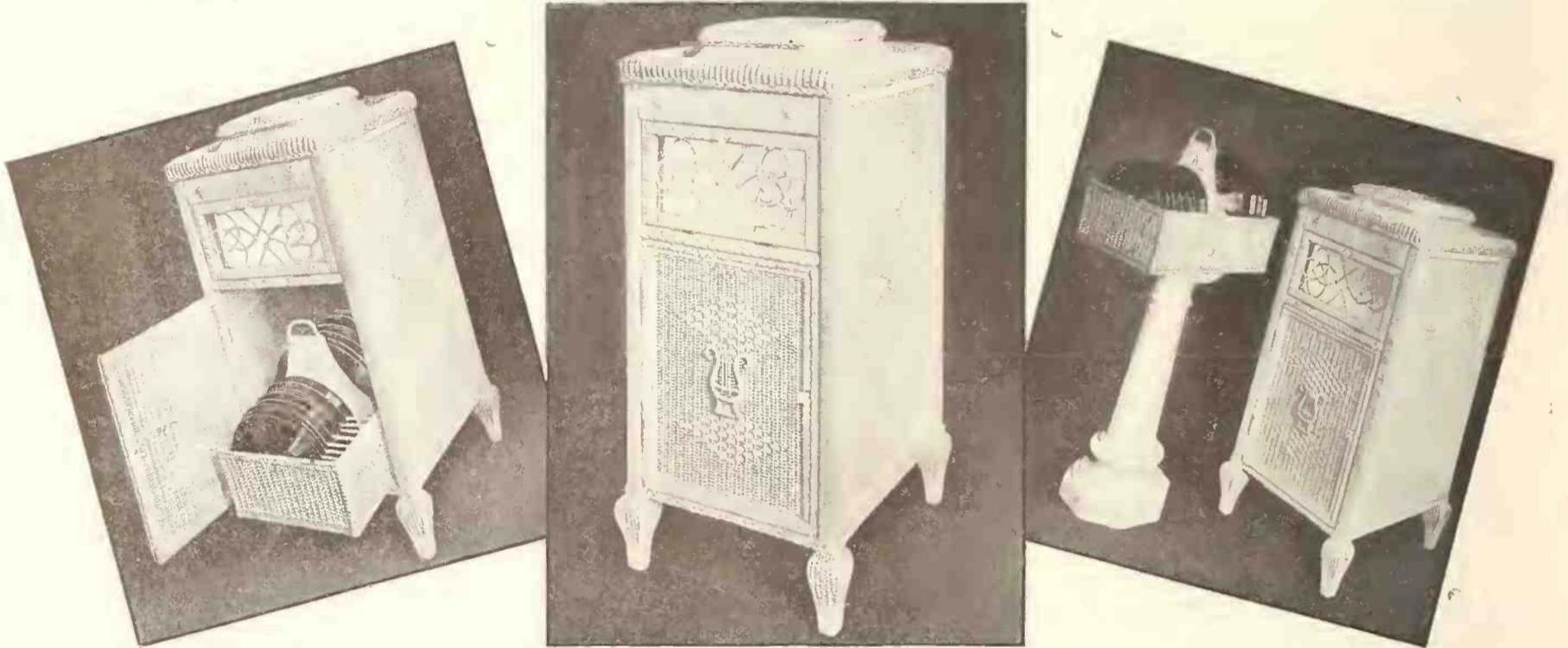

Artistic Creations in Reed Cabinets, Designed and Patented by Dr. Alva D. Jones.

effects of the use of this phonograph, one showing the instrument itself closed; another, with the record hamper open, and the third shows the record hamper removed and placed upon a marble pedestal. The utility of this new invention, which is being protected by design and other patents, is far-reaching, as can best be attested by the orders already received, even before the official announcement is made.

In describing this it is better to let Dr. Jones have the floor, for he is as clever in his descriptive conversation as he is in his creative achievements. "The principal feature of my patent," said Dr. Jones, "is that the inventor has discovered a wonderfully valuable function in the use of reed and other plaited materials when used as a talking machine cabinet, having after thousands of tests discovered that board cabinets of the usual type are subject to sympathizing with the vibrations coming from the record, and thereby setting up a tone the coloring of which is foreign to the original tones. Wood is found to be particularly valuable in the piano, which has a tone peculiar to itself and is an instrument within itself. Likewise the violin. Each of these has its own individual characteristics, which characteristics are made up in part of the wood itself, but this condition is entirely different in the talking machine, as the same must be capable of accommodating itself to the characteristics of every known musical instrument as well as the human voice.

"Each and every one of these instruments as well as vocal sounds is distinctly individual, so it is easy to understand that the talking machine cabinet as well as its reproducing instrument or sound box must be entirely void of a predominating tonal characteristic, but must be capable of preserving to their utmost the most delicate musical vibrations without the slightest change of coloring by reason of sympathetic vibratory influences.

number of craftsmen can work on it at a time, which is an entirely new procedure in the reed industry, and is also the subject matter of a patent. One beauty of the reed machine is that it may be decorated so as to accommodate itself to any furniture or room in the home. The decorations may

company will continue the original policy of the company, and the entire executive organization of the Peerless concern has been retained by them. The phonograph business will be kept entirely separate from the manufacturing activities of the Ricca & Son firm.



Truetone Combination Sets

MADE IN U. S. A.

Five different tones, each tone packed separately. 200 in a metal box, 5 boxes in a convenient container holding 1000 needles, retailing at 75c.

Five of these containers packed in a carton and sent prepaid to dealers anywhere in U. S. for \$1.50

NEW YORK DISC NEEDLE CO.

110 WORTH STREET, NEW YORK CITY

Truetone
TRADE MARK

Highest Grade
Ever Made.

SEND FOR SAMPLES AND PRICES ON OUR COMPLETE LINE

COLUMBIA CO. ANNOUNCES NEW APPOINTMENTS.

James P. Bradt Becomes General Sales Manager and W. C. Fuhri, United States Manager of That Company—Both Men Admirably Fitted by Experience for Their New Responsibilities.

John A. Cromelin, general manager of the Columbia Graphophone Co., New York, announced last week the appointment of James P. Bradt as general sales manager and W. C. Fuhri as United States manager of the company.

Mr. Bradt was formerly sales manager, and in his new and broader duties he will be in a position to give even closer co-operation to all branches of



James P. Bradt.

the Columbia service and indirectly aid the Columbia dealers throughout the country in achieving greater success than they have had in the past several years.

Every talking machine man who has had the pleasure of meeting Mr. Bradt will rejoice in his broader field of activity, as Mr. Bradt is one of the most popular members of the trade and a man whose pleasing personality and genial smile have



W. C. Fuhri.

won him hosts of friends both here and abroad.

W. C. Fuhri, who was formerly Central West district manager, is one of the oldest employes of the company, and has gained the friendship and esteem of Columbia dealers throughout the West. The creation of the position of United States manager, Mr. Fuhri's new post, became necessary on account of the greatly increased business the Columbia Co. is doing, with a proportionate increase

of problems and general work. The appointment of Mr. Fuhri is a logical one, as his many years of exceedingly successful work in the Columbia service has peculiarly fitted him for his new post.

As United States manager Mr. Fuhri's duties will be all that the title implies. He will be in direct authority on all matters pertaining to the company's United States business, and will be the executive office representative of the store managers, through the district managers, in matters of management.

IN MEMORY OF THE LATE COL. BILL.

Resolutions of Sympathy are Drafted by the National Association of Talking Machine Jobbers and Will Be Suitably Engrossed.

At the recent meeting of the executive committee of the National Association of Talking Machine Jobbers, in New York, a committee was appointed to draft suitable resolutions to the memory of Edward Lyman Bill. The resolutions, which will be appropriately engrossed and framed by the committee are as follows:

EDWARD LYMAN BILL.

was a man who held a position of honor, dignity and influence unsurpassed in trade paper annals in this or any other country. In this his life was unique. His profession will miss his great leadership. The musical industries in all their branches will with difficulty know where to turn to fill the void left by his untimely passing away. He combined with keen technical knowledge the finest qualities of character and manhood. Colonel Bill's life would have been rounded out in his chosen profession had he limited himself to it, but he gave of his power and ability not only to his splendid papers but to the whole music trade and to numerous civic duties as well. No effort for honesty and uplift in trade advancement ever found him unwilling to assume his full share in it and responsibility for it. Through the warp and woof of the fabric of his calling the thread of his life will be found for the past thirty-six years, and has bettered and gladdened it. His sudden death in the full of a fine activity leaves the profession of trade paper journalism and the musical world in general poorer indeed, and the entire community with more than the customary sense of a deep public loss. The National Association of Talking Machine Jobbers, of which he was a founder and an honorary member, orders that this minute of esteem for his memory be spread upon its records and a copy, suitably prepared, be sent to his sorrowing family and his business associates.

"And the stately ships go down
To their haven under the hill,
But oh, for the touch of a vanished hand
And the sound of a voice that is still."

JAMES F. BOWERS,
HENRY WINKLEMAN,
LOUIS BUEHN,
Committee on Resolutions.

MUSIC AS AN AID TO ACTING.

The many applications of the Edison Diamond Disc are interestingly shown in a recent installation in the Edison motion picture studio at Bedford Park, New York City, as an aid to acting. The direct and immediate effect of music on the emotions, especially "emotional" music, has long been known to psychologists. The directors, as the stage directors are known in motion pictures, are just waking up to the power of music. The director's task is to see that the actor's feelings and thoughts are so expressed that, without words, the audience will "get" them vividly. The exactions of the picture screen call for the highest form of realistic acting. This search for the real feeling has brought forth this reliance upon the Edison Diamond Disc as an emotional excitant.

The B. M. Joy Edison Shop, of Fort Dodge, Ia., recently held a tone test with Miss Helen Rudesill as the soloist.

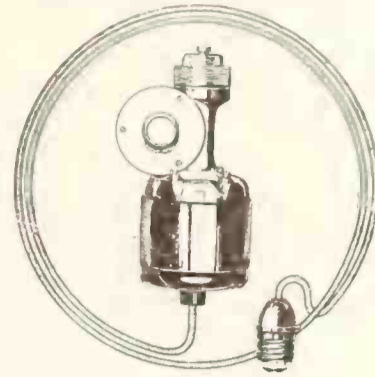

Are You a Motrola Dealer?

When we announced the MOTROLA we knew there would be a big demand—but we did not know the demand was so urgent.

The flood of inquiries and orders that have come in from almost every section of the country has proved this:

It demonstrated that wide-awake talking machine dealers know it will be easy to sell Motrolas to their customers.

Connected with electric current the Motrola winds automatically, insuring true tone and even time by keeping the machine from running down. Cost of operation practically nothing. It can't get out of order.

Simple to attach—just unscrew the winding key and put the Motrola in its place.

Be one of the first to have a Motrola for demonstration purposes. Get our literature to mail out with your monthly list of records.

Prices, terms and all further information sent on request

JONES-MOTROLA, Inc.

171 MADISON AVE. NEW YORK, N. Y.

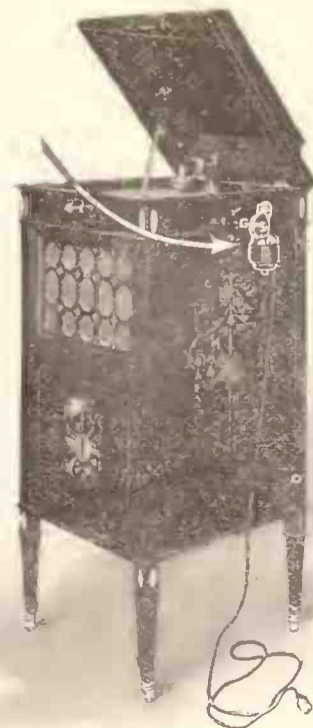

TO VICTOR DEALERS

"His Master's Voice"



A fine Gold Filled or Solid Silver Charm at \$2.00 each. Solid Gold, \$6.00. Sent to any part of U. S. postpaid, C. O. D. Special prices at wholesale.

J. FRAME ART JEWELRY

340 Superior St., TOLEDO, O.



THE UNICO



Design No. 3

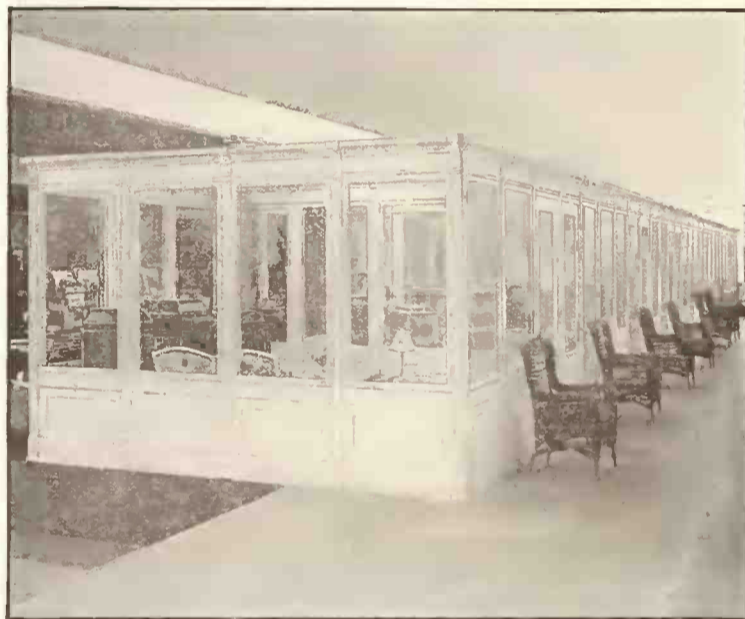

Design No. 5

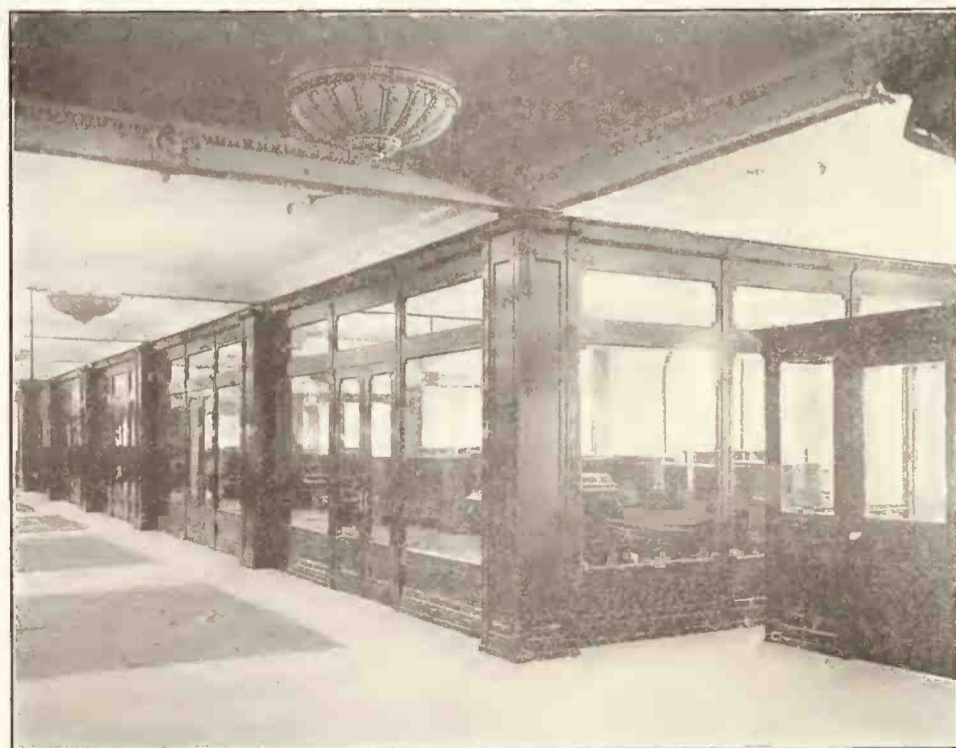

Design No. 9

The Unico System Stimulates Sales



PR
P

Talk

Pia

is the time
if you wish
assume

HOLIDAY

WE SHIP
Patent Sectional Interiors
to cover

YOU IN
No Confusion

SOUND PROOF

Demo

EFFICIENCY

T
P

Send us a card
for demonstration
and estimate

LITE

The Unico

121-131 SOUTH 31st

DISTRICT

SYSTEM



ICES
TS
chine
alers



Design No. 2

W
nico Rooms
ing trade to

PORTIONS

FROM STOCK
ily finished, fitted and glazed
ge or small.

UT DELAY
-No Annoyance

- DUST PROOF



Design No. 4

Rooms

- PROGRESS

erate
75.00

have available
ans, suggestions
mptly.

QUEST

struction Co.

ILADELPHIA, U. S. A.
PAL CITIES



Design No. 10

The
Unico
System
Guarantees
Growth



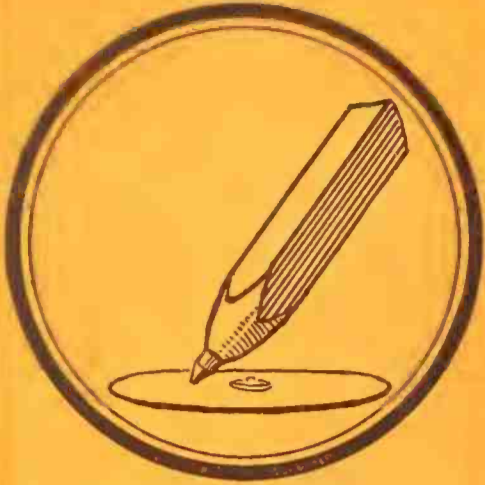

Retails for \$1.00

IF you are not carrying the Sonora Multi-Playing Jewel Needle in stock, you should do so.

It sells readily for \$1.00, and we authorize you to guarantee it to give perfect satisfaction under daily use for three months.

We supply them to you at a price which permits a satisfactory profit, and will be glad to have you correspond with us on the subject.

The Jewel Needle will save your customers records, and bring out their beauty and harmony in a way not possible to the old-fashioned, scratchy, constantly-changed *steel* needle, now being rapidly discarded by careful people.

Manufacturers of steel needles state that they must be used but once because they wear the record. This is true, and it is also true that they begin to wear the record the minute they start and keep on wearing it more and more.

Write us for sample needle and full information in regard to net prices and the "service work" which we do for those who carry our products in stock.

Sonora Phonograph Corporation

Makers of the Sonora Phonograph and Sonora Multi-Playing Jewel Needle.

GEO. E. BRIGHTSON, President,

57 Road Street - NEW YORK

INSURANCE ON VICTOR GOODS.

Victor Talking Machine Co., in Letter to Insurance Company Official, Outlined as Follows Its Policy Regarding the Handling of Machines and Records Damaged by Fire.

In response to a request made by an insurance company official, the Victor Talking Machine Co. recently sent the following written statement regarding its position with respect to settlements of fire losses in which goods of its manufacture were involved. The letter was designed to clear up certain misunderstandings in the West and was forwarded to the proper authorities. The definition of the company's stand was as follows:

"It has not been, is not, and will not be the policy of this company to question the right of insurance companies to take damaged goods of its manufacture in cases where the amount of damage thereto cannot be agreed upon and settlement made for partial loss.

"We do object to damaged goods of our manufacture being disposed of to the public in any way, as we know this can only result in damage to our reputation as manufacturers of high-grade goods. In order to avoid this we are willing to make sacrifices in the nature of allowances to distributors or dealers who suffer fire losses and who cannot otherwise agree with the insurance companies upon the value of the salvage. We think the insurance companies will be glad to extend to us the courtesy of an opportunity to confer with the assured and with the adjuster in cases of dispute, as this would no doubt result in speedy settlement and save the companies loss and expense.

"When machines of our manufacture in the hands of the trade are damaged in such a way that, in the opinion of the assured and of the adjuster, they can be refinished and made marketable, this company stands ready to do this at our factory, supplying new parts at cost and charging only for new material and workmen's time. Certainly, repairs cannot be made in any other way at so low a cost and with as satisfactory results.

"With respect to records in the hands of the trade that have been damaged, but appear to have salvage value, our plan is to offer to make an allowance on such records in exchange for new ones. This enables the assured to make a corresponding allowance to the insurance companies at our expense, and we feel that the distributor or dealer should also be willing, in cases where a large stock is involved, to stand a loss if necessary, so that the questionable goods may not be offered to the public in his vicinity to the damage of our mutual interests. If, however, even this allowance by us does not permit the assured and the adjuster to come to an agreement, we are willing to give any case careful consideration to see if there is any need or justification for a special proposition applying only to that particular case.

"In the case of machines that are damaged beyond repair and records that are burned, broken or otherwise perceptibly damaged, we presume that there can be no question but that they represent a total loss figured at the actual cost to the assured.

"In a few recent cases we have been called upon by adjusters to assist them in the manner indicated above, and we are quite sure that the results have been most satisfactory to all concerned, and especially so to the insurance companies, whose claims were very much reduced through our co-operation."

FALL IN JOIN THE ARMY OF NYOIL DEALERS AND

YOU
WILL
SHARE

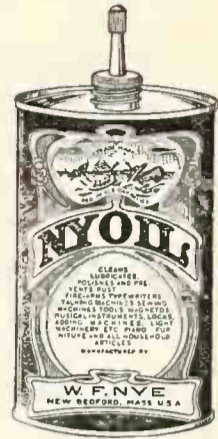

PROFITS
WITH
US

Let Us Submit Our Latest Proposition
WM. F. NYE, New Bedford, Mass.

PHONO-VOCAL METHOD A SUCCESS.

Student Writes Enthusiastic Letter Regarding the Success of the Herman-Klein Phono-Vocal Method of Voice Teaching.

The successful use of any particular system of instruction affords the greatest proof of the practicability of the system in question. The many testimonials from students of singing, and even teachers, regarding the effectiveness of the Klein Phono-Vocal Method of voice culture, based on the use of talking machine records and a comprehensive textbook, and which has back of it all the excellence of the famous school of Manuel Garcia, goes to prove its value.

The manner in which those who have used the system regard its success is indicated by the following letter, recently received by the Music Phone Method, 2 West Forty-fifth street, New York:

Kellogg, Idaho, Dec. 22, 1915.

THE MUSIC PHONE METHOD, New York City:

I expressed my approval of The Music Phone Method on receipt of the same. At that time I valued it at \$1,000, but after having studied with it six weeks its value has just doubled. All of my records are jealously guarded and kept under lock and key when not in use. I have expended in the neighborhood of \$2,000 with some of the best teachers of vocal music to be found in the West, but still I was not satisfied. I have the well-known fault that most all average singers have got, and that is lack of proper breath and throat control. The trouble of all teachers is that they try to teach how to overcome such faults, but not how to prevent such faults. Now it is clear to anyone with the average brain that it is much easier for a person to keep from getting a sore throat than to doctor and overcome the same when once it has got hold of him. Their excuse for this is that they are afraid of mystifying a pupil, but that is just what they do. I came to this town to get together enough funds to go ahead with my voice, but am pleased to say that the Herman Klein Phono-Vocal Method has solved the financial end of it for me. I have in the Music Phone Method the greatest of all teachers. You are given permission to use this in any way that will help music lovers to take advantage of this great opportunity. I would be pleased to answer any letters from ones who would like a heart-to-heart talk with one of your students. Wishing you all kinds of success, I remain Sincerely yours,

N. S. CLARK.

Those issuing the method have received similar letters from many students and also letters from members of the trade regarding the success of the system as a selling proposition.

"MAGNET" DECALCOMANIE NAMEPLATES

FOR TALKING MACHINE
CABINETS ETC.

We can furnish the same or similar style as shown herewith, according to the price scale given below.

	250	500	1000
Gold letters, black edged . . .	\$12	\$15	\$20
Black letters, solid gold background, with fancy border	\$16	\$20	\$25

Samples upon application,
GEO. A. SMITH & CO., Inc.
136 Liberty Street, New York, N. Y.

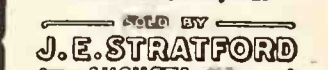

NEW CONCERN TO MAKE "TALKERS" IN PHILADELPHIA.

Horace Sheble Is President of the Domestic Talking Machine Corp., Chartered with \$200,000 Capital Stock, to Enter Manufacturing Field on Large Scale.

The Domestic Talking Machine Corp. was recently incorporated at Philadelphia, under Pennsylvania State laws, for the purpose of manufacturing talking machines, records and accessories. Its capital stock is \$200,000, all of which is said to have been subscribed. The president of the corporation is Horace Sheble, who is a talking machine authority of international distinction.

The company expects ultimately to build its own plant, but for the present large quarters have been



Horace Sheble, President.

secured at Thirty-third and Arch streets, the building in which it is located being one of the finest modern factory plants in the country, being of strictly fireproof construction throughout.

It is the intention of the company to manufacture everything entering into the construction of its product, with the exception of woodwork, so as to enable it to effect every possible saving in manufacturing cost and place on the market a line of low-priced machines that can assume leading proportions in the trade. As the company has ample backing, it is planned to discount all bills and at every angle effect all possible legitimate savings and put them into building up and standardizing the quality of its product.

President Sheble has gathered around him an efficient and loyal staff of specialists, each man to head his respective department and to be in absolute charge. Putting responsibility on capable men Mr. Sheble has found is the only way to secure the best results.

Philip C. Adams has been appointed general sales manager. While the phonograph field is new to him, he is a merchandising man of marked ability, and the sales end of the company has every opportunity of being well handled.

The superintendent of the plant is Thomas Kraemer, who

for many years was connected with the Singer Sewing Machine Co. He was also superintendent of the Regina Music Box Co., and later on superintendent of the Hawthorne & Sheble Manufacturing Co. Mr. Kraemer has contributed many patents to the development of the talking machine art and is an authority on mechanical matters and modern shop practices.

The purchasing head of the company is A. C. Wright, who was formerly purchasing agent for the American Graphophone Co., and is considered an expert in his chosen field of work.

The accompanying photographs show the officers of the Domestic Talking Machine Corp.

"Looking over the phonograph field, the success of the various companies has generally been limited to the powers of the men who are actively responsible. Some of the new companies have been started by men unfamiliar with the industry, and it is doubtful to-day," said Mr. Sheble, "if more than a few of the companies engaged in the manu-

facture of talking machines are making money. It reminds me of a number of years back when the bicycle business was in its prime. Every other

bicycle dealer started to buy parts and assemble in order to be classed as a manufacturer, imagining by such a process he could compete with those actually manufacturing. It did not take long for such conditions to seek their own level.

"It is our intention to manufacture machines under our own patents, and through the facilities and ample capital available I believe our company will shortly be prepared to offer most attractive conditions in low-priced talking machines.

"Our plant is at present being equipped throughout with the most modern machinery, so as to enable us to conduct the work we have in mind in a most efficient manner. I do not care to show illustrations of our various types at this time, but they will be ready shortly, when the proper trade announcements will be featured."

The Domestic Talking Machine Corp. starts with a complement of men who have been brought



A. C. Wright, Purchasing Agt.

up in the manufacturing business, men who have seen this important business grow from small things to big ones, and who have actively participated in its growth, so the company is exceptionally well fortified from both a managerial and financial standpoint.

INVENTORIES AND STOCK RECORDS.

Should Be Safeguarded, Says F. K. Dolbeer, In Recent Letter.

F. K. Dolbeer, manager of the credit department of the Victor Talking Machine Co., recently sent out a letter to Victor jobbers and dealers impressing upon them the necessity of keeping their inventories and records regarding stock in a safe place in order to protect their insurance. In part Mr. Dolbeer said:

"One of our distributors recently sustained a heavy loss by fire, and the fact that he was in a position to produce a copy of an inventory taken December 31, 1915—together with other papers bearing on the subject—was of material aid in enabling him to promptly prepare a proof of loss which was acceptable to the insurance adjusters, so that a settlement was obtained within ten days from date of fire."

VISITING TRADE IN THE EAST.

A. Anderson, of the credit department of the New York Talking Machine Co., New York, Victor distributor, is making extended trips through the Eastern section of the country in order to investigate general conditions in the respective local territories and call upon Victor dealers. Mr. Anderson has already visited Pennsylvania, Massachusetts and sections of New York State, and will continue these trips indefinitely. These visits will undoubtedly aid the New York Talking Machine Co. to render its dealers an even more efficient degree of co-operation than it has in the past.

The Bailey Furniture Co. has added pianos and talking machines to its line of furniture, the Victor, Edison and Columbia machines being handled under Manager John L. Young.



Landay

BROS

Offer Victor Dealers an Unusual Opportunity

It is unusual because Landay service gets right at the heart of your business problems.

Landay Brothers can solve your problems because they know the retail business thoroughly.

Hence, Landay Brothers are prepared to render you assistance or advice on

Stock
Financial problems
Selling problems
Advertising problems.

Put your difficulties up to us today. Remember our confidence is based on PRACTICAL EXPERIENCE.

Write us today—no obligation on your part whatsoever.

P. S. Do you know that Landay offers to dealers a special window card service of unusual character? Ask us about it.

Landay

BROS

Victor Jobbers Exclusively

569 Fifth Avenue
New York, N. Y.



THE HOME OF LANDAY BROS.

THE TRADE IN NEW YORK CITY AND VICINITY

The month of February was a very satisfactory one for the local talking machine trade, and is best summed up in the remarks of several dealers and jobbers that the sales totals of the month were as large as might be expected for a month that had thirty-one days and no holidays, instead of twenty-nine days and two holidays.

The general situation in the trade shows no material change from last month; February business being far ahead of last year and exceeding that of any February in the history of the local talking machine trade.

There is still a tremendous shortage of machines of all types and classes, and this scarcity of product is becoming more acute day by day. Factories are working to capacity, but the demand has been so far beyond all expectations that human calculations could not foresee it. The record situation is far better than it was a few months ago, and

there is very little complaint regarding the shortage of records of any particular class. Standard selections are selling well, and there is a steady call for dance records and the better class of popular selections.

Dealers Interested in Important Problems.

The most interesting features in the local talking machine trade is the fact that the dealers are evincing a keen interest in general matters which are applicable to the talking machine trade from a broad viewpoint. The Stevens bill is attracting the attention of a great many of the local dealers who in accordance with the request of the National Association of Talking Machine Jobbers, have written to their Congressmen and pointed out that the Stevens bill when enacted will prove beneficial to manufacturer, dealer and consumer, particularly the latter.

Other topics which have been discussed by the

local dealers are salesmanship, better terms and a more definite understanding of the "record on approval" question. The dealers are making plans to develop their salesmen along more efficient and result-productive lines than in the past, as they realize that the present prosperity of the talking machine trade can only be maintained by intelligent salesmanship of the very highest type.

A number of the local dealers have expressed their displeasure with the newspaper advertising which makes a feature of "nothing down" and ridiculously low terms. It is more than likely that some action on this matter will be taken by the local association within the near future. The record approval question has always been a thorn in the side of the progressive and wideawake dealer, and this important subject is being discussed from every angle, with the idea of protecting the dealer from losses through the improper use of the "record on approval" privilege.

Stevens Bill Activity.

J. Newcomb Blackman, president of the Blackman Talking Machine Co., New York, Victor distributor, in company with Messrs. Mickel, Rauth and Nestor, of the legislative committee of the National Association of Talking Machine Jobbers, made a special trip to Washington recently in the interests of the Stevens bill. This committee held a number of important conferences with prominent Congressmen with the object in view of obtaining an early hearing for the bill. The members of the committee do not feel at liberty at the moment to disclose their actual plans, except to say that they were successful in enlisting the support of high distinguished officials, and the general outlook for the Stevens bill is extremely favorable. The American Fair Trade League is greatly pleased with the work done by the National Association of Talking Machine Jobbers' committee, and they refer to it as most effective when compared to the efforts of any other organization. Mr. Blackman states that it cannot be urged too strongly, however, that each dealer write to the members of the Interstate and Foreign Commerce Commission, showing their great interest in the holding of an early hearing on the Stevens bill.

The Blackman Talking Machine Co. reports the closing of an excellent February with a good increase over the corresponding month of last year. Mr. Blackman points out that if the company is able to get enough goods to continue this ratio of increase during March and April it will wind up with a very fine business year on April 30.

Attractive Window Display.

Referring to the general outlook and last month's business, Raymond Duncan, of the Edison Shop, 473 Fifth avenue, which is owned by the Phonograph Corporation of Manhattan, said: "February sales were very gratifying, and both phonographs and records shared in the general trade. Our concerts in our auditorium have been well attended, and we have plans now under way whereby a number of prominent artists recording for the Edison diamond disc records will appear at special recitals singing in conjunction with their own records." The Edison Shop is featuring this week a window display which is attracting the favorable attention of all passers-by. This display includes the popular models in the Edison Diamond Disc and Amberola line, while in the center of the window is shown a sectional view of the Diamond Disc reproducer. This is displayed under a magnifying glass, and thousands of people have stopped to examine the display when passing the Edison Shop. Mr. Duncan states that he is planning to install similar educational displays every fortnight as the success of this first display has been phenomenal.

Record-Breaking February Business.

"February business was as big as though the month had thirty-one days and no Sundays or holidays," said R. F. Bolton, district manager of the Columbia Graphophone Co., New York. "Not-

(Continued on page 32.)

Reliability

Your greatest consideration in the selection of a distributor.

A studied knowledge of your needs, and a personal interest by our sales organization as well as the house force, make it possible for you to rely upon us and feel confident that your interests are having our best thought always, and the best possible attention.

We have successfully served the dealer for over 82 years.



C. Bruno & Son, Inc.

ESTABLISHED 1834

Victor Distributors to the
Dealer Only

351-353 FOURTH AVE., NEW YORK

WE DO NOT RETAIL

The
New York Talking Machine Company

Devotes a Wealth of Time, Energy—
 and Money—in Active Profit-Producing
 Co-operation With Victor Dealers.

“We Deliver More Than Merchandise”

Below is one of five display cards with
 which we are covering the “big”
 records of the Victor April List.—

This Service Is Open to all Dealers.—

It Pulls Customers into the Store

WRITE US



Hear THIS Record 17928
That's all—
Just Hear It !!



TRADE IN NEW YORK AND VICINITY. (Continued from page 30.)

withstanding the enormous volume of business and the increase over last year, we were still unable to take care of our dealers' requirements, although our manufacturing facilities were increased considerably. Other additions to our factory are now being made, and within the next thirty or sixty days we hope to be able to take care of our dealers' needs promptly. The larger types of machines are still in big demand, and the models selling at seventy-five dollars and upward are easily in the lead. Record business has shown a phenomenal increase, giving ample evidence that our advertising campaign is not only doing us lots of good, but is also proving of vast benefit to our dealers. Judging from the business closed during the first two months of the year, it is very evident that 1916 will be a much larger talking machine year than 1915. Collections are very good, which would testify to the fact that our dealers are enjoying a large measure of prosperity and selling their machines on good terms. Orders for fall are being received in large quantities, and the dealers are making plans far ahead of time to forestall any possible shortage during the latter part of the year."

Better Factory Shipments.

V. W. Moody, sales manager of the New York Talking Machine Co., Victor distributor, in a brief summary of February business said: "Our company still feels the continuous scarcity of all types of machines. Factory shipments were somewhat more substantial during February than the preceding months which enabled us to maintain a proportionate increase over last year. The record situation is good, and the demand for the better class of popular music is evident. This is a pleasing indication, because the customer who buys good substantial music never tires of his instrument, while the owner of a machine who does not appreciate good music often tires of his machine very quickly."

Open New Columbia Department.

Spear & Co., the well-known furniture house which has opened a new building on Thirty-fourth street near Fifth avenue, is maintaining a very attractive talking machine department devoted to the Columbia line exclusively. J. A. Friedman, well-known in the local talking machine trade, is manager of this department, and he has arranged to carry a complete stock of machines and records and give the Columbia line aggressive exploitation.

De Luxe Model in Popular Demand.

"Our sales last month very nearly equaled those of December," said George Thornton, Jr., of the Pathé Shop, 487 Fifth avenue, which handles the products of the Pathé Frères Phonograph Co. exclusively. "The best selling Pathephone during the month was our new \$225 DeLux model, which is being sold as fast as we can receive the stock from the factory. The artistic lines of this instrument have won praise from all our customers, and we expect this model to be the leading

Pathephone in this territory. Record sales were very satisfactory, and the records which are now being produced at our factory are being praised by experts as representative of the highest type of record production. During the past week or two we sold a number of complete sets of operatic music to well-known people in the musical world. Our customers are awaiting with interest the first records made by Muratore, the celebrated tenor, and there will certainly be a big demand for these records." One of the recent additions to the sales staff of the Pathé Shop is George Oliver, formerly connected with Thomas A. Edison, Inc.

Heavy Featuring of Records.

In chatting with a World representative agent business conditions, Charles F. Bruno, C. Bruno & Son, Inc., 353 Fourth avenue, Victor distributors, reports that conditions are fine and that from the sales sheets there is every indication of dealers featuring records in a very heavy way. "Special attention in the record field, I find, is prolific of not only financial results, but when a customer gets into the habit of coming to a dealer's store, and he gets the right kind of service, he is bound to continue business. It behooves dealers, therefore, to maintain a good stock of records so that they won't have to subject their customers to the inconvenience of waiting for several days."

Best February in History.

Thomas H. Fletcher, retail manager of the Aeolian Co., in a chat with The World said: "February was the best month in the history of the retail division of the Aeolian Co. Our Aeolian-Vocalion department achieved phenomenal sales totals, and our figures for the month show a very large increase over February of last year." The Aeolian Co. is conducting a remarkable campaign in the local newspapers on behalf of the Aeolian-Vocalion. This campaign is particularly noteworthy for its dignity and effectiveness, the sales arguments being presented most interestingly.

Active Record Trade.

The G. T. Williams Co., 217 Duffield St., Brooklyn, N. Y., Victor distributor, closed a very satisfactory February, notwithstanding the general shortage of all types of Victrolas. The company reports a very active record market with the dealers enthusiastic regarding the outlook.

Excellent Newspaper Publicity.

The Sonora Phonograph Corporation carried a splendid full page advertisement in the rotogravure section of one of the leading Sunday newspapers. This advertisement presented the Sonora salon at Fifth avenue and Fifty-third street, and also featured the "Invincible" model of the Sonora line. The advertisement was unusually effective, the delicate rotogravure tints being in harmony with the dignified character of the text.

Duplicate Fall Trade.

"Our dealers report an even greater demand for Victrolas and Victor records than they experienced during the fall months," said R. H. Morris, of the American Talking Machine Co., 368 Livingston street, Brooklyn, N. Y., Victor distributor. "We all appreciate, of course, the fact

that there is a tremendous scarcity of machines, but it is certainly gratifying to note that our dealers are closing a bigger business than ever before. This also applies to our own institution."

"BILLY" DOES THE ANNOUNCING.

Younger Scherman Tells of the Arrival of a Nine-Pound Advertising Man in the Family —A Decidedly Novel Announcement.

The Columbia Graphophone Co.'s advertising department has achieved distinction throughout the trade because of the originality and individuality of the various publicity ideas which it has sponsored. This idea of originality is characteristic of each and every member of the department,



Billy Scherman and His "News."

which includes William S. Scherman, one of the most popular members in the Columbia executive offices.

Mr. Scherman is so imbued with this doctrine of originality that it was only to be expected that his friends would receive a decidedly original announcement of the arrival at his home on March 2 of a nine-pound baby boy. He did not disappoint his friends, as each one of them received a post card similar to the picture shown herewith. As the text so well sets forth, there are now two boys in the Scherman family, and "Billy" Scherman, who announces the arrival of his new playmate, is already giving indications of following in the footsteps of his father by displaying a keen interest in the Columbia product and a fondness to try out unique, though intensely practical, ideas.

EDISON SPRING WEARS WELL.

There was recently received at the factory of Thomas A. Edison, Inc., Orange, N. J., a set of old style concert phonograph spring barrels for the purpose of having the springs renewed. The spring barrels belong to a machine owned and used by A. M. Neill, of Hatboro, Pa., for the past sixteen years, and the only fault found was that the springs had relaxed. Mr. Neill ordered new springs supplied as soon as possible so that he may again have the use of his phonograph.

A section containing a diagram of a record and a list of records with their respective prices. The list includes titles like 'I Wish I Was a Rich Man's Son', 'The Merry Widow', and 'The Song of the Flute'. Prices range from \$0.10 to \$1.00.

Advertisement for BEE CROFT. Features the BEE CROFT logo with a bee. Text reads: 'Record Delivery Envelopes Are Cheaper Than Wrapping Paper and String'. Below this, it lists 'Record Delivery Envelopes', 'Record Stock Envelopes', and 'Catalogue Supplement Envelopes'. To the right, it lists 'Perfection Record Holders', 'Long Cabinets', 'Needles', and 'Peerless Locking Plates'. At the bottom, it says 'CLEMMENT BEECROFT, 309 W. Susquehanna Ave., PHILADELPHIA'.

The Shelton Motor Increases Machine and Record Sales



Retail Price, \$17.50

Patents protected by our own and allied interests. Injunction and accounting will be asked for against any manufacturer or dealer making or selling an infringing motor.

The Shelton Electric Motor will enable you to sell an "electrified" machine to every prospect who enters your store. It can be used equally as well on a \$25 machine as on a \$200 machine. It also increases record sales by stimulating the customer's interest in music and creates a new enthusiasm in his machine.

The Shelton Electric Motor is simply placed against the turntable, and does not require even the turning of a screw. It does not interfere with the spring motor in any way, but, on the contrary, *saves* the spring. Either motor may be used as desired. Made for any lighting circuit. Instantly attached and is not affected by fluctuation of current.

Write to-day to nearest office for dealer discounts and special proposition.

SHELTON ELECTRIC CO.

NEW YORK—30 East 42nd Street
 CHICAGO—30 East Randolph Street
 BOSTON—101 Tremont Street
 SAN FRANCISCO—62 Post Street

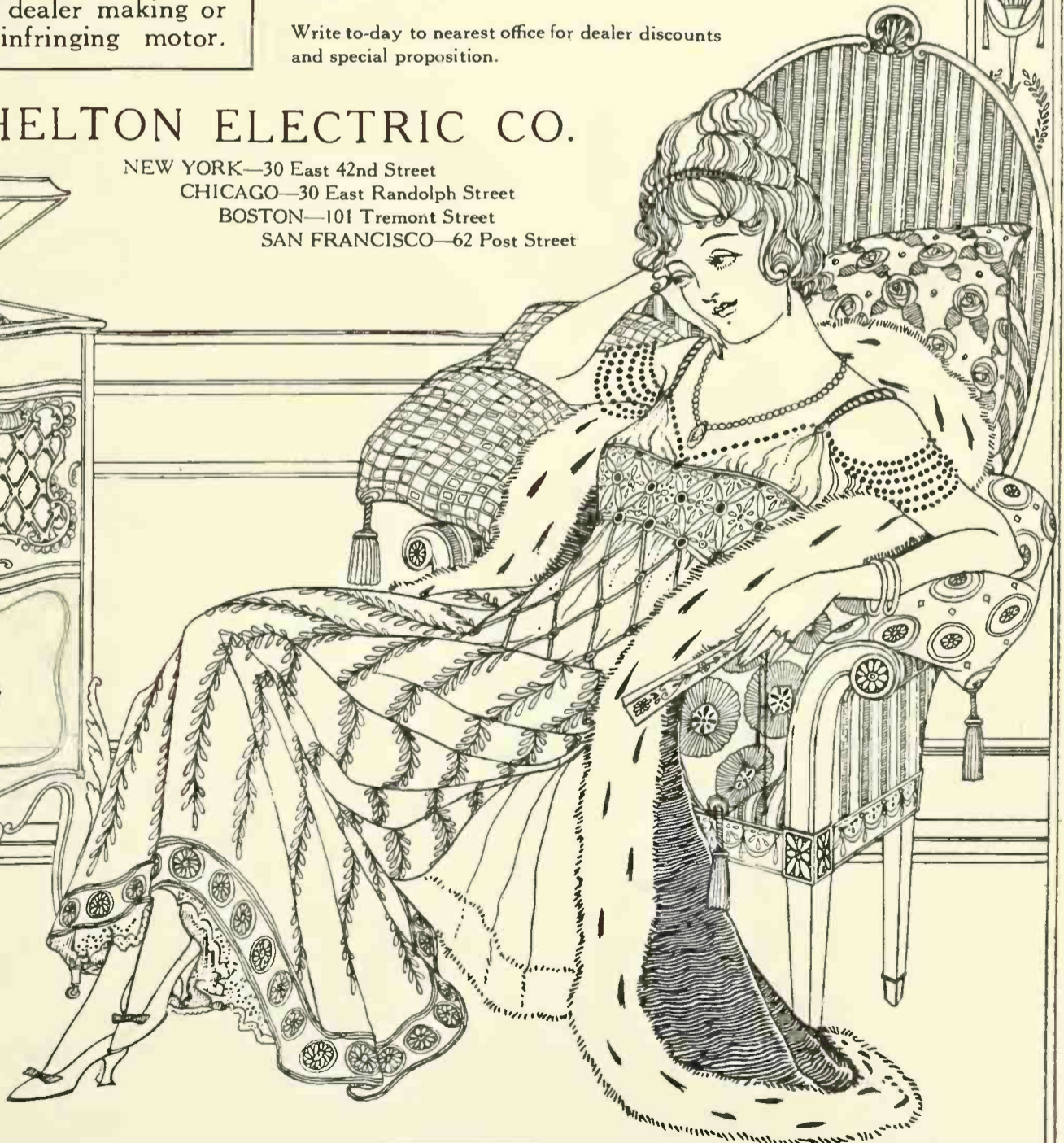
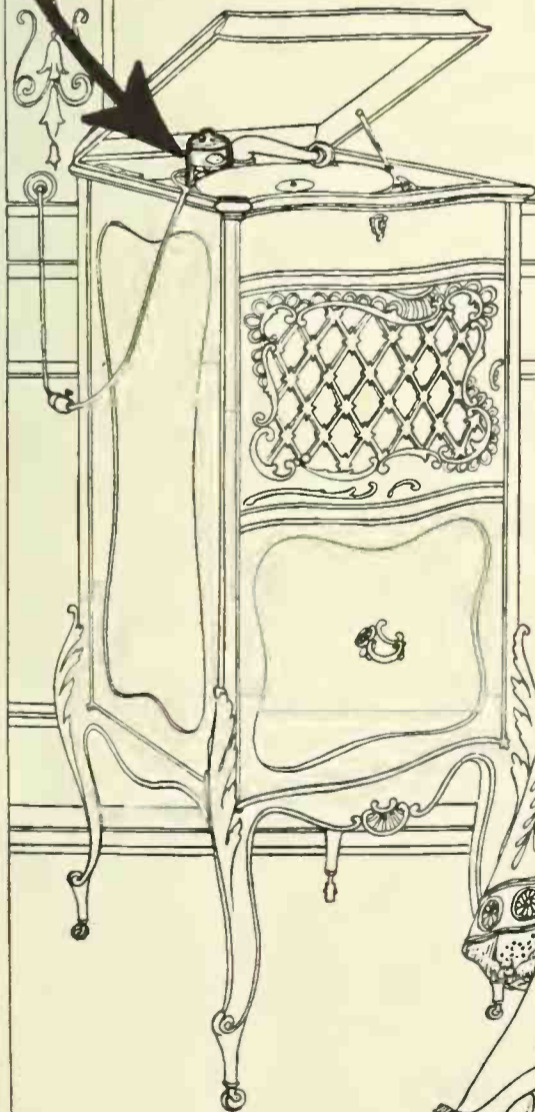



Can you imagine anyone saying there would be no demand for Ysaye records? Or Seagle records? Or Casals records? And can you imagine anyone trying to offer you substitutes for records by artists such as these?



(Write for "Music Money," a book "full of meat" for those dealers interested in quick and frequent turnover of capital.)

Columbia Graphophone Company
Woolworth Building, New York

UP-STATE VICTOR DEALERS ACTIVE.

V. W. Moody, Sales Manager of the New York Talking Machine Co., Finds on Trip Retailers in New York State and Pennsylvania Making Preparations for Unusual Business.

V. W. Moody, sales manager of the New York Talking Machine Co., 119 West Fortieth street, New York, Victor distributor, returned last week from an extended trip through New York State and Pennsylvania. Mr. Moody's observations and



V. W. Moody.

comments regarding his trip are most gratifying in that they indicate that without an exception Victor dealers throughout this territory are making improvements and preparations for an increased Victor business which is little short of astounding.

As outlined below by Mr. Moody, the activities of many of the Victor dealers visited on this trip will give a good idea of the optimism and prosperity of the entire Victor retail fraternity.

In Rochester, N. Y., Burley & Biesinger, whose home office is in Buffalo, have recently taken over the store of C. Kurtzmann & Co. and are remodeling the entire interior. The store is being redecorated, and the installation of additional booths and record racks has been contracted for, together with an elaborate outdoor electric sign. Sibley, Lindsey & Curr, prominent department store, has moved its Victor department from a basement location to a prominent third floor space, installing new booths and new record racks. Edwards & Co., another large department store, are making very material improvements in their Victor department.

In Syracuse, N. Y., W. T. Crane has taken a new store on Salina street, and is converting the main floor into a Victor department, with sufficient display room for a limited number of art pianos. Leiter Bros., Salina street, are also preparing to make extensive alterations and improvements.

In Binghamton, N. Y., Fowler, Dick & Walker are installing four more booths in addition to their already substantial equipment.

In Wilkes-Barre, Pa., Landau's music and jewelry store has just completed an installation of ten modern booths.

In Scranton, Pa., Stoehr & Fister are making in-

terior alterations and installing two handsome machine exhibition parlors.

In Allentown, Pa., G. C. Aschbach is making one of the most radical alterations of any of the dealers visited by Mr. Moody. This concern has moved its Victor department from the second to the main floor, and a battery of record and demonstration rooms and a magnificent reception salon have been constructed. Hartman & Laushe, who have just entered the Victor business, are installing substantial and modern equipment, and when alterations are completed will have a most attractive store.

In Easton, Pa., the Victor department of W. H. Keller & Son shows a remarkable development that is most gratifying. A few years ago this concern had a very small exhibition of Victor machines and records, with practically no department and situated far back in the extreme end of the store. A short while ago the Victor line was put into the center of the store and a few demonstration rooms installed. Now the company has a Victor department which is one of the finest that can be found in the East. It is located in the most prominent part of the store, and the officers of the store are trying to figure ways and means whereby they can install additional rooms.

The American Vitaphone Co., capitalized at \$400,000, was incorporated in Delaware this week for the purpose of engaging in the manufacture of talking machines. The incorporators are: Charles H. Howe and Ira L. Cochrane, of Plainfield, N. J., and Claude Wheeler, Columbia, Mo.

A BIG TALKING MACHINE CENTER

is the Republic Building, Chicago, Where Eleven Different Machines Are Displayed.

(Special to The Talking Machine World.)

CHICAGO, ILL., March 9.—What is perhaps the most comprehensive display of talking machines in any one building in the Middle West, and perhaps in the country, is to be found in the Republic Building at 209 South State street. Here, under one roof, the talking machine buyer has his choice of eleven machines, which range in size from the small metal variety to the largest cabinet machines. On the ground floor is found the Pathé Shop. On the fourth floor in the establishment of A. H. Rintelman can be found the Vitanola and the Vanaphone. On the fifth floor in the Tone Shop are displayed the Columbia, Edmundson and the Wondertone. On the seventh floor the Columbia is again found in the warerooms of F. S. Spofford. The Sonora phonograph can be had on the tenth floor; the Lyraphone is shown in the Lyraphone office, also on the tenth floor; the Knabe-Crystola on the eleventh floor in the office of Al. Bruckner; the Playerphone on the sixteenth floor, and the Ariol on the seventeenth floor.

INCORPORATED.

The Synchronophone Co., of Chicago, has been incorporated with a capital stock of \$15,000. The incorporators are N. D. Cross, W. F. Mayer and J. P. Grier. The proposition relates to talking machines in combination with moving picture films.



Pathé



MR. WIDE-AWAKE DEALER
WE WANT YOU—AND YOU WANT US

If you are not handling PATHEPHONES you are behind the times. The PATHEPHONE is the greatest Musical Instrument ever Created.

We are prepared to supply your wants Quickly, Accurately, and Promptly. Write or Wire us. Your territory may still be open.

A. VICTOR & CO.

PATHEPHONE DISTRIBUTORS

Main and Genesee Sts. - - - - Buffalo, N. Y.

RECORD SALES A BIG FACTOR IN BALTIMORE TRADE

Recent Visits of John McCormack, Billy Sunday and Others to That City Serve to Stimulate Business—Columbia Graphophone Co. Withdraws from Local Retail Field—Wholesale Trade Excellent—Stock Shortage in Various Lines Being Relieved—News.

(Special to The Talking Machine World.)

BALTIMORE, MD., March 9.—A good talking machine business for February was reported by most of the houses, despite the fact that there was still a shortage of goods by most of the houses and there was not as good a supply of records the first part of the month as the demand required, but toward the latter part of the month the supply came along in good shape.

There were several things that helped to stimulate the sale of records during the week. One was the appearance of John McCormack in a recital at the Lyric. A great deal of space was devoted in the newspapers to him, and many of the firms of the city used advertising space to call attention to his numerous records. All of the shops reported a big sale of the McCormack numbers.

"Billy" Sunday in Baltimore is also aiding record sales, especially those records that have the Homer Rodeheaver hymns. Rodeheaver, who is Sunday's musician, gave quite an interview on people dancing to his music in Philadelphia.

One of the big changes in the local field was the announcement of the passing of the Columbia Graphophone Co. entirely out of the retail business in this city. In future the Columbia headquarters here will handle only wholesale business and take care of distributing to its customers in this city and the field it handles. A. J. Heath, who has brought the business of the Columbia line along by leaps and bounds in the less than a year and a half that he has been here, will remain in charge of the local headquarters of the Columbia.

The Columbia headquarters on North Howard street where both retail and wholesale business was handled by the Columbia and which is a very attractive establishment, will be continued as a retail emporium under the name of the Columbia

Grafonola Shop. A. & J. Oldewurtel, the pioneer Columbia dealers in this city, and who conduct Columbia stores at 307 South Broadway and 566 North Gay street, will conduct the Grafonola Shop. The entire Columbia establishment remains at the Howard street shop and an entire new and modern equipment for distributing the Columbia line will be established in a new five-story modern warehouse on West German street.

"Business is good with us," said Mr. Heath. "Despite the cry of shortage of machines, business of February went ahead of February of last year by a good margin. The new Columbia headquarters, which will be strictly wholesale, will permit us to carry ten times the amount of stock on hand and we will also carry the full American and foreign series of records. In a little while there will be no shortage of machines."

The entire Columbia staff will go with Mr. Heath to the new headquarters with the exception of W. E. Collins, who has become assistant manager to Mr. Crowley in the talking machine department of the Hub. W. L. Eckhardt, of Philadelphia Columbia headquarters, visited here this week.

For E. F. Droop & Sons Co., Inc., Victor distributors, Mr. Roberts said: "February to us was a disappointment. We failed to get near enough machines and we ran back a little on February of last year. There was also a shortage in records, but toward the end of the month records came along in pretty good shape and that helped to stimulate the business, which was especially noticeable in the increased demand for McCormack records after his appearance here."

Jesse Rosenstein, for the National Piano Co. Pathé distributors, reports a good business in his line, with an increased supply of machines coming

in and the customers of the firm are becoming better pleased. Two new firms—the Royal Furniture Co., 510 South Broadway, and William J. Wieland, 3509 and 3511 Eastern avenue—are now handling the Pathé line.

The Sanders & Stayman Co., Inc., the Vocalion representatives, report a big business here. Last week twenty machines of the \$100 and \$150 style were received, and all were sent out with the exception of two before the close of the same day. The firm is well pleased with the way the line is going. The company will move to its new headquarters the latter part of May.

Cohen & Hughes, Inc., Victor distributors, report a good business, but raise the cry of old—shortage of machines—but the business showed an increase just the same.

H. R. Eisenbrandt Sons, Inc., are unable to meet the great demand for Victor machines, so great is the local demand.

Milton Boucher, manager of the Victrola department of William Knabe & Co., reports that he is short of Nos. 10 and 11 machines. There has been a great increase in the record business.

Five large, sound-proof booths have been installed by the Hammann-Levin Co., dealers in Victor goods. The facilities for handling records also have been doubled. These improvements have been made on the first floor.

G. Fred. Kranz, president of the Kranz-Fink Talking Machine Co., is critically ill with pneumonia at his home. Alarm is felt for his recovery. He is one of the most popular men in the city in both the musical and business world and has a host of friends.

A unique feature of the Junior Assembly ball at the Belvidere last week was the sending out of invitations on a talking machine record. Those who received the records had to have a machine to understand what it was all about, and quite a few machines were sold through the unique scheme.

A new soundproof demonstration booth has been installed in the talking machine department of the Kipp music store at Manhattan, Kan.

LONG CABINETS

WELL MADE THROUGHOUT

ELEGANTLY FINISHED

These With Others Comprise the

Most Complete Line of Record Cabinets

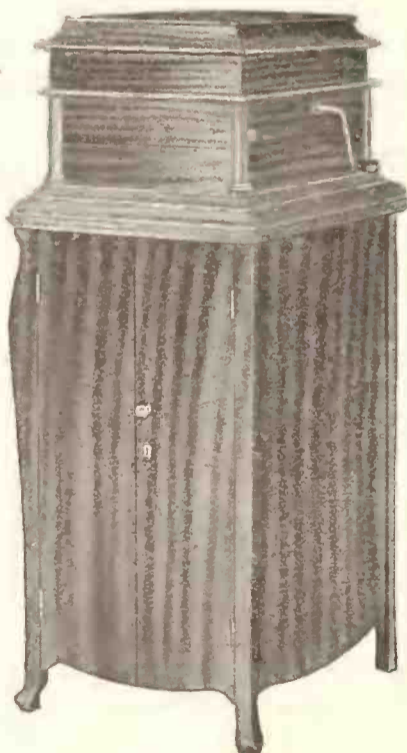

D 77 Mahogany, Golden Oak, Fumed Oak, Weathered Oak. Height 34 in. Top 19 1/4 x 22 5/8 in. Holds 192 12-in. Records. For Victrolas VIII and IX, and Columbia "Favorite." No countersunk holes in top. Sliding Record Shelf. Average weight, crated, 80 lbs.

D 79 Mahogany, Golden Oak, Fumed Oak, Weathered Oak. Height 34 in. Top 19 1/4 x 22 5/8 in. Holds 192 12-in. Records. For Victrolas VIII and IX, and Columbia "Favorite." No countersunk holes in top. Sliding Record Shelf. Average weight, crated, 85 lbs.

PROMPT DELIVERIES ON ALL ORDERS

Write for Illustrated Catalogue

THE GEO. A. LONG CABINET CO.,
HANOVER, PA.

PLANS FOR JOBBERS' CONVENTION.

Special Attention to Be Given to Educational Work at the Annual Gathering of the National Association of Talking Machine Jobbers to Be Held at Atlantic City in July.

The tenth annual convention of the National Association of Talking Machine Jobbers will be held at Atlantic City, N. J., the old favorite stamping ground of the jobbers, on July 10, 11 and 12, and for the first time since the conventions have been held at Atlantic City the headquarters will be made at the Hotel Traymore instead of the Chalfonte.

The entertainment committee of the association, of which A. A. Trostler, of the Schmelzer Arms Co., Kansas City, is the chairman, is fast completing arrangements for the convention and is outlining an attractive and ambitious program. Beyond the handling of the routine association business, the tenth convention will be devoted chiefly to educational work and constructive talks on the part of the members of the association and factory officials.

As the program is now mapped out tentatively, the business meetings will be held on Monday and Tuesday afternoons, leaving the mornings open for bathing, sailing or other pleasures in which the conventioners may desire to participate. Wednesday will be "Educational Day," when various talks on the different phases of the business will be listened to.

On Thursday, July 13, the members of the jobbers' association and their families will be the guests of the Victor Talking Machine Co. and will enjoy a special program provided by the company. Judging from past conventions there will be nothing lacking in the line of entertainment.

In view of the plans now under way, it is expected that the annual convention of the National Association of Talking Machine Jobbers for 1916 will be one of the most resultful in the history of the association. No effort will be spared by any of those in charge of the matter to make the convention instructive and profitable as well as

entertaining to the many jobbers who are confidently expected to attend.

CLOSES IMPORTANT PATHE DEALS.

J. F. Collins, Sales Manager of Pathé Frères Phonograph Co., Meets with Much Success on Recent Trip Through the South and West—Reports General Wave of Optimism.

J. F. Collins, sales manager of the Pathé Frères Phonograph Co., New York, returned to his desk last week after an extended trip to the leading trade centers in the South and West, when, among other things, he closed several important deals



J. F. Collins.

whereby prominent concerns in this territory will be enrolled in the ranks of the Pathé jobbers. The names of these new distributors will be announced in the near future.

Referring to general conditions, Mr. Collins said: "From the reports I had previously received from our jobbers and travelers I had expected to find a fair measure of prosperity in the sections I visited, but I must admit that I was unprepared to find such a general wave of optimism and splendid in-

dustrial activity in every city, regardless of size.

"General conditions are excellent, and Pathé jobbers report the closing of a February far beyond their highest expectations. Pathé dealers are well pleased regarding the outlook for Pathé development, and in Chicago, where the employes of the Pathé Shop gathered for short talks on the Pathé product, optimism was substantiated by the individual enthusiasm of every man. All models of Pathephones are meeting with popular favor, and the American recordings of Pathé discs are being praised on all sides. My trip as a whole was gratifying in every respect."

Mr. Collins' comments regarding conditions are worth more than passing attention, as he is one of the veterans of the talking machine industry although a young man in point of years. He has been associated with every phase of talking machine development and has achieved signal success in his present important post.

THE PERFECTED THORPE MOTOR.

Interesting Development in That Talking Machine Accessory—Plans for New Factory.

Since making the first announcement of his improved electric motor for talking machines, some time ago, Walter Thorpe, 29 West Thirty-fourth street, has made a number of perfections in the motor in the matter of the standardization of parts, and plans are now under way for the equipment of a new factory in Mount Vernon, N. Y., for the manufacture of the motors in a large way. The low voltage on which the motor operates makes it possible to attach it to the ordinary electric light fixture without detracting from the usual value of the light or adding materially to the current consumption. For demonstration purposes the motor is also shown by a double switch with both direct and alternating current, and may be changed from one to the other without any appreciable halt in the operation of the motor or the playing of the record.

There are several new developments in the manufacture and sale of Thorpe electric motors that will be ready for announcement shortly.

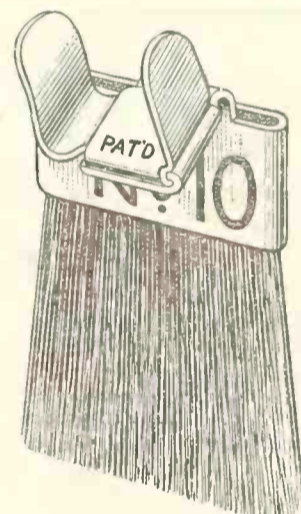
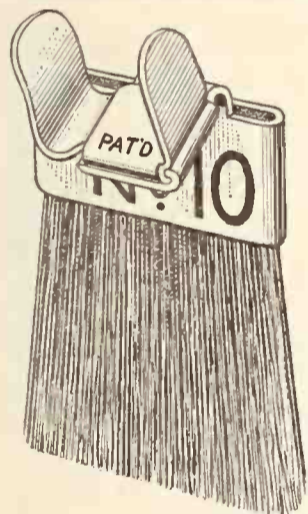

Patented Sept. 25, Oct. 2, 1906; Sept. 7, 1907.

Price 25c.

Grit is a Fine Thing in a man, but one of the Worst Things in a record groove

Easily Attached
Works Automatically

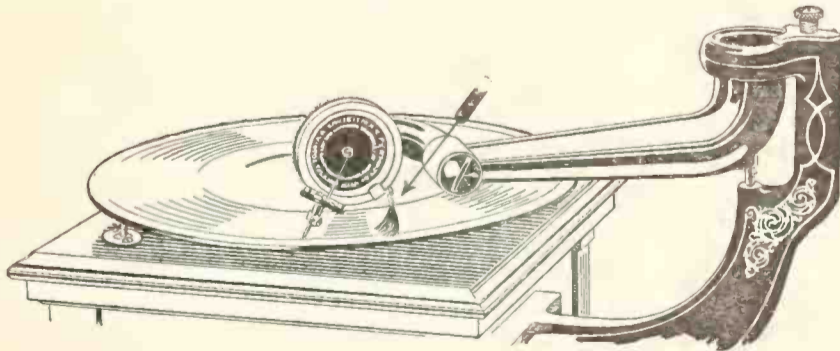

By removing all dust and dirt from the Record Grooves a clear reproduction is insured.

Every Jobber and Dealer Should Handle These Brushes. Sample and Discounts Mailed on Request



Blackman
TALKING MACHINE CO.
97 CHAMBERS ST. NEAR CHURCH ST. NEW YORK
VICTOR DISTRIBUTORS





No wonder!—we have the right instruments and the right range of prices; we have the artists and the right records. The dealer has the right discounts and every day the public demand for Columbia product grows.



(Write for "Music Money," a book "full of meat" for those dealers interested in quick and frequent turnover of capital.)

Columbia Graphophone Company
Woolworth Building, New York

TRADE IN SOUTHERN CALIFORNIA.

Coming of Good Weather Brings Thoughts of Spring Business—Shortage Still Exists on Certain Types of Machines—Victor Co. Officials Call on Chas. Ruggles—The Pathophone Shops Opens—Caruso's Gift Stolen.

(Special to The Talking Machine World.)

LOS ANGELES, CAL., March 6.—Now that the rains are over and the weather finally settled down to normal, southern California is looking forward to a good spring business. Reports from most of the local dealers suggests that more business would be done if more stock could be obtained. There are still several finishes of machines in all makes that it is impossible to get on the Coast. A great deal of unjust criticism is being directed toward the dealers from customers who are using other finishes temporarily, while waiting for another machine.

The Birkel Music Co. was closed two days last month on account of the death of Mrs. George J. Birkel.

Eldridge R. Johnson, president of the Victor Talking Machine Co., and L. F. Douglas, vice-president of the same concern, accompanied by Andrew G. McCarthy and Philip T. Clay, of Sherman, Clay & Co., San Francisco, made a short call on Charles Ruggles, the local representative from Sherman, Clay & Co., a few days ago.

A. Graham Cook, the talking machine manager for the Birkel Music Co., exclusive Victor dealers, says business was never better and is on the increase.

Clifford R. Ely, special representative of the trade promotion and wholesale departments for the Columbia Graphophone Co., is making a visit to the Coast. Mr. Ely is very well satisfied with business conditions in the West and looks for better times soon.

Mr. Hopper, of the Eilers Music House, Seattle, Wash., is making a short visit in Los Angeles. Mr. Hopper says they are opening a new store in Tacoma, Wash.

F. A. Dennison, the new Pacific Coast manager for the Columbia Graphophone Co., who succeeded W. S. Gray, has been in the city the last few days getting acquainted with the trade and looking over this territory in general. Mr. Dennison was formerly manager of the Columbia Co. in Detroit for several years.

A new talking machine store has been opened at 621-23 South Hill street under the name of "The Pathophone Shop." E. M. Bonnell, the well-known talking machine man and entertainer, will be in full charge. Mr. Bonnell is well and very favorably known in the world of music, having vast experience in that line for many years in Los Angeles. The Pathophone Shop will handle Pathophones and records exclusively. It will be one of the most modern and best ventilated parlors in Los Angeles. Daily concerts will be given by the company.

An old-fashioned phonograph presented six years ago to the Rev. James Tonello, 2360 Ivanhoe avenue, by the song bird, Caruso, was stolen from the minister's home late Saturday by an intruder. The machine was the only article taken by the burglar.

POPULAR FOR SCHOOL USE.

How the Columbia "Favorite" Is Utilized in the Huntsville, Ala., School.

(Special to The Talking Machine World.)

HUNTSVILLE, ALA., March 6.—The Roy F. Ott Talking Machine Co. recently installed a Columbia "Favorite" Grafonola in a local school which is giving perfect satisfaction and is proving an important factor in the school's daily work. Re-



Exercising to Music of Grafonola.

ferring to this machine, Mr. Ott recently said: "The first thing upon the opening of the school each morning is heard the 'Favorite' as the entire school marches to the tune of a very lively march until each room is closed. The machine is then carried to the chapel, where several operatic selections are played, subsequent to which it is used for calisthenic drills on the playground. At noon-time the older girls use it for an enjoyable dance.

"I make a visit to the school every thirty days with several selections from a popular opera or some good violin records, with a general run of educational records. The children are very enthusiastic regarding the machine, and the teachers state that they could not get along without it."

TO ENLARGE ST. CROIX PLANT.

Albert Paillard, Head of the Sonora Factory in Switzerland, Visits New York Headquarters.

Albert Paillard, head of the Sonora factory at St. Croix, Switzerland, was a visitor to New York during the first part of the month, where he was in daily consultation with President George E. Brighton and Secretary Joseph Wolff, of the Sonora Phonograph Corp., 57 Reade St.

Plans were consummated with Mr. Paillard that will greatly increase the output of the Swiss plant in order to take care of the rapidly increasing business which is being booked by the Sonora Co.

Mr. Paillard reports no better conditions industrially throughout Switzerland, as far as manufacturing goods is concerned, than those in this country, there being a decided shortage in the necessary metals for the production of motors.

BRITISH FIRM WANTS MOTORS.

A firm in the United Kingdom writes The Talking Machine World that it is desirous of getting in touch with some American manufacturers of talking machine motors and accessories. Full information will be sent to those interested on application. Address The Talking Machine World, 373 Fourth avenue, New York City.



The VICSONIA

Puts Edison Record Music at the command of every one owning another leading make of phonograph. Doubles the value of their machine.

The VICSONIA reproduces Edison disc records perfectly on Victrola, Grafonola, Sonora and Crescent phonographs. Special type for Aeolian Vocalion.

The VICSONIA, with its WONDERFUL DIAPHRAGM and jewel point, is a revelation in reproducers.

Tested and endorsed by trade experts.
Easily attached without altering any part of machine.

The VICSONIA retails in the United States for \$7.50, nickel plated; \$8.50, gold plated. Liberal discounts to dealers.

Write for our exclusive territory proposition.

One Vicsonia, Nickel, will be forwarded any dealer in the United States for \$4, or in Canada for \$5. Cash with order.

WALTER M. SEYMOUR (Sole Agent Vicsonia Mfg. Co.) 311 E. 134th St., New York

EDISON FEATURES FOR EASTER.

Two Old Easter Carols by the Carol Singers—
Notable Artists Represented in Some Classic
Numbers Suitable for the Season.

The revival of the old Easter carols has been aided materially by the recording on Edison Diamond Disc records, by the Carol Singers, of two old favorites, "The Happy Bells of Easter Day" and "Let the Merry Church Bells Ring," both carols that have been sung at Easter since time immemorial. The makers of these records consist of a group of vocalists gathered together for the explicit purpose of reproducing these old songs and preserving them for posterity.

In connection with the two carols, the Edison special Easter record list contains a number of other selections that are particularly appropriate to the season. "Agnus Dei," one of the sacred compositions of Bizet, the composer of "Carmen," sung by Marie Rappold, and "He Shall Feed His Flock," a recitative and air from the "Messiah" of Handel, sung by Christine Miller, are two of the most notable of these Easter numbers. Another splendid feature of the list is "I Know that My Redeemer Liveth," from Handel's "Messiah," sung by Julia Heinrich, of the Metropolitan Opera Co. Other selections that are particularly appropriate for the Easter season are Granier's "Hosanna," sung by Arthur Middleton, bass of the Metropolitan Opera Co.; "Coronation March" and "Praise Ye," Sodero's Band; "Ave Maria," Bach-Gounod, Charlotte Kirwan, soprano, and Isidore Moskowitz, violinist; "With Virtue Clad," Marie Sundelius, soprano; "Soft Southern Breeze," Reed Miller, tenor; "Gloria," Twelfth Mass, Mozart, Gregorian Choir; "Hallelujah Chorus," Handel, Oratorio Chorus. Altogether, the Edison Laboratories have almost surpassed themselves with an offering of records that have a most particular appeal at the Easter season.

COLUMBIA USED IN HOTEL.

New Model Concert Grand Attracts Much Attention and Is Used for Hotel Dances.

(Special to The Talking Machine World.)

COUNCIL BLUFFS, IA., March 10.—A Columbia Concert Grand Grafonola, one of the new models of talking machine fashioned after a baby grand piano, attracted much interest Sunday at the Grand Hotel, and again Monday evening, when it furnished the music for the Monday Night Club's dance.

Factory representatives have been demonstrating the Grafonola here for some time. The new model is operated with an electric motor which is the same as that used in the Dictaphone, and has an automatic switch which stops the motor at the end of the record.

INVENTS SHOCK ABSORBER.

A. C. Rutzen Devises Talking Machine Accessory Which Eliminates Rasping Sounds.

(Special to The Talking Machine World.)

CLEVELAND, O., March 10.—A shock absorber for talking machines has been invented by A. C. Rutzen, the inventor of the spring motor, which will eliminate 90 per cent. of the rasping, popping sounds, it is claimed. The device is half as big as a man's thumb, and connects the needle with the sound box. It holds the needle at an angle of 90 degrees, instead of 45, and thereby is supposed to save wear and tear on records.

PROFESSIONAL DEPARTMENT BUSY.

The professional department of the Columbia Graphophone Co., which is established at the recording laboratory, 102 West Thirty-eighth street, New York, has been unusually busy the last few weeks, and Henry D. King, manager of the department, reports the closing of numerous deals with well-known artists in the professional field. The records recently made under Mr. King's direction by Weber & Fields, Bert Williams, Frank Tinney and Miss Marguerite Farrell are all achieving success, and Columbia dealers are ordering them in large quantities.

INCREASING ITS FACTORY OUTPUT.

The Artophone Co. Closed Big Month in February—Many New Jobbing Agencies Established—Good Work of Robert H. Cone.

(Special to The Talking Machine World.)

St. Louis, Mo., March 6.—The Artophone Co., 454 North Boyle avenue, closed an unusually good month in February, and at the present time has plans under way to materially increase its factory output, although the capacity of the plant was doubled only a short while ago. Although it has been establishing many new jobbing agencies and on an average of ten new dealer accounts every day, the company has been able to get out all its orders within a week's time.

The Artophone Co. is also organizing a record department, which will be in full swing about May 15, and which will enable the company to supply its dealers with a complete line of records.

The success that the Artophone Co. has achieved may be attributed in a considerable measure to the excellent quality of its product and the splendid executive and sales organization which is di-

recting the company's affairs. During the past few weeks several letters have been received from well-known music lovers in this city praising the Artophone machine and commenting particularly upon the value and quality represented in the No. 55 Artophone which retails at \$55.

Robert H. Cone, Jr., president and treasurer of the Artophone Co., is a man of unusual aggressiveness and force. He is thoroughly conversant with all phases of the talking machine industry and is extending to Artophone dealers service and cooperation which is producing profitable results for the individual dealer.

Many a man who in his small village is considered an example for the highest ambition would fail to attract attention in a large city. Many another man whose ambition for power and wealth has never been rewarded in the great city needs only to change his location a few miles, and, presto! he is great and rich on the instant.

John Lewis is now in charge of the talking machine department of the Harless & Frasold store at Gulfport, Miss.

**"Masked Marvels"**

THERE are no masked marvels in the distributing business. Everything is out in the open, with the exception of the brains back of any house. In spite of our fire, and we are rapidly getting into shape, we are doing more business from ALBANY in a week than has been done before in two months.

This is 866% increase, and in our new quarters, backed by an able staff, we will increase this percentage. Dealers are with us everywhere, because we actually render SERVICE. There are no plays at substitution; no drawn-out time between letters or orders; no "stalls" in answering questions, nor any other attempt to make your work hard when you are needing the machines and records to make the profits you should get.

Nowhere in this country has a distributor shown such amazing growth as the Gately-Haire Co. Why not find out for yourself why this is so?

GATELY-HAIRE CO.

JOHN L. GATELY, President

JAMES N. HAIRE, Treasurer

New Address: 121 North Pearl St.

ALBANY, N. Y.



"Albany—for Capital Service"



THE TRADE IN THE SOUTH.

VIRGINIA TRADE UNUSUALLY ACTIVE.

Higher Priced Machines and Records in Big Demand—Heindl Working to Assist Dealers —“Machines That Play with a Plate.”

(Special to The Talking Machine World.)

RICHMOND, VA., March 6.—It is astonishing to note the unusual business conditions existing in the talking machine trade of Virginia. Reports from various parts show an unusual scarcity of stock, while the demand is greatly in excess of any previous year.

An interesting feature in connection with the record trade is the fact that the higher priced records are enjoying the center of most activity from a sales standpoint, while the machines selling from \$100 to \$200 also have a big market. Dealers report very little trouble from a collection standpoint, this being no doubt due to the fact that there is plenty of money in circulation and that the population of the State is getting its share of the present industrial prosperity.

Louis A. Heindl, of Walter D. Moses & Co., Richmond, Va., Victor distributor, when interviewed by a representative of The Talking Machine World, stated that at the present time every energy is being utilized for assisting the dealer.

“Owing to the shortage of cases,” he remarked, “every time we get a shipment we are up against a problem, for we have more orders on hand than the total number of cases received. Many times we are short in our retail department simply to help out a dealer who has a sale that it is necessary to close, but we are believers in service to the dealer.”

It seems to be the impression that cylinder records and machines are in great demand among the colored people of the South, but E. Bowman, of C. B. Haynes & Co., of this city, stated that while his house transacts a large business in Edison cylinder records and machines, the colored trade buys very little of this particular class of merchandise. It seems that this trade wants “the machines that play with a plate,” and he says that it is seldom that you find anyone of African hue referring to records as being disc records. They are all “plates.” Consequently, the sale of Edison Diamond Disc phonographs, for which the Haynes Co. is a wholesale distributor, is big with all classes of trade.

Mr. Bowman went on to say that the stock of cylinder records constantly on hand embraces about 40,000, and that the outlying districts, particularly in the farming section, are an excellent market for this class of merchandise.

J. G. CORLEY DOUBLING WAREROOMS.

Site Has Been Secured for the Erection of an Addition to Present Warerooms—Will Be Devoted Exclusively to Wholesale Trade.

(Special to The Talking Machine World.)

RICHMOND, VA., March 6.—In the minds of the trade there is an association of Richmond and Corley that makes these words synonymous. The trade will be very glad to know that preparations



J. G. Corley.

are now in force whereby the extensive warerooms of the Corley Co. in this city will practically be doubled. Some time ago J. G. Corley, head of this organization, acquired the land running from the back of his present location on Broad street right through to Grace street, the latter rapidly becoming the high-class business street of the city. Ground will be broken in May, and by September 1 it is the expectation of the company to be well settled so that the fall business can be properly handled. With the new addition the entire ware-room will be 300 feet long. The space in the basement is 150 feet long by 60 feet, and the addition gives a space 150 feet long by 30 feet, a total of approximately 14,000 square feet, which will be devoted exclusively to the promotion of the wholesale end of the Corley Victor business, the latter being under the charge of F. W. Corley and Fred R. Kessnich.

In addition to the use of this big building the

company also maintains a large warehouse wherein an adequate stock of both pianos and talking machines are stored.

“Richmond is excellently situated,” said F. W. Corley, “so that it can take care of Victor dealers from the South in an efficient manner. We enjoy fine transportation facilities, and by the plan of co-operation that we utilize in not only securing dealers but in holding their confidence in business, we are enabled to show a rapid growth in sales from month to month.”

Mr. Corley went on to say that the business situation throughout the South is greatly improved, and his idea is that this will be a banner year.

AS AN AID TO THE SHY.

“As I think back,” said Aunt Martha, “I wonder how we can ever get along without the phonograph.

“We would talk for a time to the shy young man caller about the weather, and then we would discuss the coming church picnic and hope we would have good weather for that, but that about used up our topics of conversation.

“It helped a little for me to play two or three pieces on our good, old square piano, but when I swung around on the piano stool—there were not so many piano benches then—we would come to another silent spell; and then pretty soon the shy young man would say:

“Well, I guess I’ll have to be going now.”

“But now,” went on Aunt Martha, “why, now when the conversation lags you have the phonograph.

“Oh, have you heard this?” you say to the shy young gentleman, and then you put on the disc and crank the machine.

“From that time on there is no trouble. In the course of time, when the young man rises to go, you hear not, ‘Well, I’ll have to be going now,’ but this, ‘My! I didn’t know it was so late,’ spoken with animation. He has had a pleasant evening.

“Really, it seems to me that to shy young people the phonograph is nothing less than a blessing. I don’t know how we ever got along without it.”

The business man who comes in daily contact with the commercial traveler can have but one opinion of him—respect.

DO IT NOW! YOU HAVE CAPITAL INVESTED IN YOUR STOCK. IT WILL BE SECURE IF THE STEVENS BILL PASSES THE NEXT CONGRESS.

“The Best South of the Mason and Dixon Line”

VICTOR RECORDS SUPPLIES REPAIRS SERVICE

QUICK DELIVERIES—LOW FREIGHT RATES—DEALER HELPS

3 GOOD REASONS WHY YOU SHOULD MAKE US YOUR VICTOR JOBBER

Foreign Records

—there’s a growing demand in every cosmopolitan community for folk songs of foreign climes. We can supply them in every language, including Chinese and Japanese.

The magnitude of our stock enables us to make immediate shipment. The magnitude of our stock enables us to fill your orders without delay—from stock. That counts in turning prospects into sales! Test our SERVICE next time.

Victor Repairs

—there’s tangible profit in this for the dealer. Factory-trained experts and up-to-date equipment puts us in a position to handle your repairs with profit to you.

The Corley Company

The South’s Leading Distributors

213 EAST BROAD STREET, - - RICHMOND, VA.

COMMENTS ON THE "RECORDS ON APPROVAL" POLICY

Views of an Independent Observer on a Question Now Being Discussed by Talking Machine Dealers Throughout the Country of Interest—Takes Both Sides of the Question in Detail and Makes Some Valuable Suggestions Along Constructive Lines.

[At the present time there appears to be a well-defined movement among talking machine dealers in all sections of the country to cut out the plan of sending out records on approval. In many cases the privilege of testing and selecting records at home has been grossly abused by the customers with the result that the dealers have been forced to curtail or eliminate entirely the approval scheme from their business for their own protection. There is another side to the story, however, and a talking machine owner, who is a reader of *The World*, offers the following as the view of the customer on the approval privilege. The opinion is worthy of the close attention of the dealer.—EDITOR'S NOTE.]

There is a good deal printed in the columns of *The World* nowadays about what the dealers have to say regarding the subject of sending records on approval, but nothing is heard of what the consumer thinks of the matter.

As a consumer who has taken out many records on approval, and who owes his present interest in talking machines to this method of selling records, I desire to express a few opinions on the subject, both pro and con, and also to make a few suggestions which may possibly prove valuable to dealers and consumers alike.

To begin with, suppose we marshal the facts in the case, first taking those for records on approval, then following up with those against, and winding up with one or two practical suggestions.

FOR.

1. Many people do not have the time to visit the store and listen to several records.
2. Very few booths are anything like sound-proof, therefore it is difficult to hear the reproduction perfectly.
3. Most booths are small and the customer is forced to sit within a foot or so of the machine. This makes it hard to judge a record properly.
4. Attendants often rely on the use of the loud needle to offset distracting noises in the store, and as a result the customer forms an erroneous opinion of the volume of tone.
5. Records played in the home, on the owner's own machine, give the effect that he is paying for, and not a false effect.
6. The store enlarges its customers by selling records on approval, for by this means it serves just so many more people.
7. If the customer invites friends to his house to listen to the records which he has taken out, one or more of these friends may become a possible customer. I know of a case in point. A neighbor of mine who had never heard a talking machine came to my house and listened to some approval records, with the result that in a few weeks she purchased a \$100 "talker."
8. There is a psychological basis for the fact that a great deal of the pleasure connected with talking machines lies in playing the records yourself. This pleasure you are debarred from when you hear them in the dealer's store.
9. If other people are waiting a turn to try out records it is trying to a nervous person to endeavor to concentrate his or her attention on the reproduction of a record played in the store. This element of hurry is absent when the records are taken home.

AGAINST.

1. Customers are careless in handling records; they are spread out in piles on a table instead of being kept in envelopes when not being played.
2. Customers use loud needles, or use one needle for several different records.
3. Customers drop the sound box on the record with too much force, driving the point of the needle in the margin or in the grooves themselves.
4. Customers allow the needle to remain on the record after the reproduction is finished, causing the label to become marred.
5. In using the automatic stop customers swing the point of the needle too near the record and frequently scratch the surface.
6. Customers do not always clean their hands from grease or food before using the records, leaving spots which gather gritty dust.
7. Customers crack records and do not report the fact.

8. Customers often return *all* the records taken out without making a purchase.

9. Unless sufficient actual business results from letting out records on approval the cost of handling and the attendant losses will show a debit on the account.

10. Sales of records are sometimes lost through the records themselves being out on approval.

Doubtless, my friends, the dealers could supply many more points against the "on approval" system. They probably know of abuses of which I have not been aware, such as the substitution of records on the part of the customer. Right here let me say that I believe that this whole situation is susceptible of improvement through the medium of education. By this I mean education of the dealer and his clerks as well as of the public.

As charity begins at home so should education likewise. From my own observations I am positive that 50 per cent. of the damage that is done to records is the work of careless or ignorant clerks. It is incredible the way the records are handled in some stores which I have visited. Records are piled on chairs, tables, even on the floor; exposed to dust, heat and injury from striking. They are often wedged so tightly in the racks that they become cracked in the process of moving in or out. Loud needles are used exclusively because of the volume of tone produced. The same needle is used for two or more records just because it is too much trouble to open up a new package.

Let the dealer watch for the conditions which I have outlined, and, having found them, let him call his force together and give them a talk on the proper way to handle stock. It is not necessary to be censorious or sarcastic in this matter; such a course will defeat itself. Remember the human element must be treated with tact. If an offender will not or cannot improve, then eliminate that one from the store force.

Through the clerks the public can and must be educated how to handle records. I am convinced that most of the damage done to records on approval is through ignorance. Too many clerks regard the sale of a machine the same as the sale of a pair of stockings; in other words, something which the customer knows how to use and which he cannot misuse. Now, a talking machine is really a musical instrument, and the average buyer knows little or nothing about the possibilities of abusing it. Clerks should not wait to be asked for information about how to handle machines and records; they should volunteer it, though, of course, the information should be imparted in a tactful manner.

There is another way of educating the public in the proper use of records taken out on approval, and that is through a system of application blanks. Let every customer who takes out records sign one of these blanks each time, and let him live up to the terms therein, and I'll wager he will absorb more or less information in a few months.

Here is a sample form which may be adapted to local needs:

JONES' MUSIC HOUSE, Jonesville, Conn.:

The undersigned makes application for the use of . . . records, as per list, to be kept . . . days, and agrees to the following conditions:

1. Only fibre or Tungs-tone needles will be used in playing the records.
2. The needle must be lowered *carefully* onto the margin of the record and pushed into the first groove.
3. Records must not be removed from the envelopes and spread on a table while playing. Keep all records covered except the one which is being played.
4. The hands must be free from grease or dust when handling records.
5. All cracked or broken records must be paid for.
6. In case of damage to the label by the needle point, either that record or some other from stock must be kept.
7. . . . of the records must be kept, either selected from the lot or from the stock on hand.
8. Records must not be loaned to others than the applicant.
9. Do not allow children or incompetent persons to run the machine while trying these records.
10. When not playing the records keep them in their envelopes, flat, in the box in which they are shipped, all the 12-inch ones on the bottom and all the 10-inch ones on top.

Signed
Address

I respectfully submit the above ideas to my friends, the dealers, as the result of experience gained on the other end of the proposition.

**Mr. Dealer:—
This Cabinet
Sells on Sight—
Because**

—your customer files or finds any record instantly—adding 50% to enjoyment of his Record Library.

The Simplest, Quickest System ever invented with largest capacity for records—at lowest filing cost. Creates a new interest and starts the overloaded customer to buying records again.

BIG PROFIT FOR YOU

—order a sample to-day naming your Jobber.

Unit Holds
360 Records



Combination Model 1-A-300 adjustable for 10" and 12" records. All finishes to match machines.

A One-Section Crown and Base Unit, capacity 360—10" or 12" records (Index numbers included). \$15.50.

Extra sections for Records, Music Folios, Player Rolls, etc., can be added as required.

Mrs. S—, in Erie, says:

"My Music Room was full of cabinets and albums—now my 900 records are all in reach and I can locate any one record in a moment. You should sell thousands as I've never seen a system to compare in any way with this—I will need one more section soon."

Special Models for Dealers' Stock

Models No. 1 and 2 for 10" and 12" Records. Models No. 3 and 6 for 10" only. Model No. 8 for Pathe and all size Records. Estimate furnished on complete system for any size stock.

Capacity of each Section, 300 Records. Prices of Sections, \$4.50 each to \$20.00 for Solid Mahogany and Circassian Walnut.

Write For Special Booklet

Ogden Sectional Cabinet Co.
Lynchburg, Va.



No talking machine dealer can legitimately expect to get all the profitable possibilities out of his locality if he is not showing the exclusive Columbia Grafonola models to his customers.



(Write for "Music Money," a book "full of meat" for those dealers interested in quick and frequent turnover of capital.)

Columbia Graphophone Company
Woolworth Building, New York

LACK OF TRAINED SALESMEN IS FELT IN ST. LOUIS.

Demand for Salesmen Who Know the Technical Details of Machines Far Exceeds the Supply—Silverstone Holds Educational Meetings for Dealers—Electric Machines Much in Demand—The Advantages of a Good Trade in Records.—Other News.

(Special to The Talking Machine World.)

St. Louis, Mo., March 9.—Whenever a St. Louis talking machine dealer wishes to dream of happiness he outlines his plan for work when he gets an ample stock of machines in his warerooms and is assured that he will have his future orders filled promptly and with the styles of machines that he orders. There are some dealers in St. Louis who have not yet straightened out all of the kinks that got into their trade during Christmas. There is no dealer in St. Louis, so far as a casual inquiry shows, who feels that he can organize an up-to-date, energetic campaign and be assured that he will not have to slow up by the time he is in fairly good working shape.

But there also is another fly in the ointment for the dealer who wants to go ahead. This is the lack of trained, competent, talking machine salesmen. Manager Hallahan at Aeolian Hall voiced this need. He said:

"We recently have put on three men, one who was with us some time ago, and two new ones. The new ones were hired on their personality and we are having school for them and some of the old ones every day. It is impossible to hire desirable men these days who know what a talking machine is in detail. The trade is using up competent men faster than they are being made. A trade campaign must be organized with green men. The business is so new and it recently has changed so that the men who come in for jobs are not really fitted for the work.

"Until recently talking machines were sold as a novelty and the field was so great that actual competition was not the big thing. The really im-

portant thing was to convince the prospect that they could afford to buy a talking machine. Now most prospects know that they want a machine, which they regard as a musical instrument. The one big question is what machine to buy. They must be shown where they get the most for their money. The man must know his own machines intimately, inside and out; also he must know the other machines. He must know something about tone and about music.

"All of these things are advancing the salesmanship requirements of the business to a point where it is not possible to pick up a man who has been successful in selling any old thing and expect him to get results."

Mark Silverstone, of the Silverstone Music Co., jobbers of Edison Disc machines, holds the same ideas as to training salesmen, and in organizing his sales force has devoted much time to technical details. Recently he has been much interested in training the retail dealers and their repair men. These dealers are frequently invited to come to the Silverstone Co. warerooms, bring their repair men along, and have any mysteries of the inner workings of the machine explained. The dealers show much interest in these meetings. The first of this month there was an enthusiastic meeting of this sort at the Edison warerooms, at which D. Lossen, a mechanic from the Edison laboratories, was present to explain the changes in the motor and to instruct the newcomers in the rapidly growing army of repair men.

At the Columbia warerooms Manager Irby W. Reid is drawing maps of the excellent prospects for this spring, and says that he has completed all

means of preparations except the supply of munitions, but at the rate that machines are coming now he will be able to give less time to the distribution problem and more to advancing business. According to the financial data for this trade district gathered by Mr. Reid, the present year will be the very best ever. His scouts have reported on practically all sections of his division. Wholesale Manager Salmon agrees fully with this view, and says that the city trade alone would have absorbed the entire supply of machines a good part of this winter.

J. J. Bennett, the wholesale ambassador, has finished up some deals in Illinois and is going south to see if Arkansas and Mississippi are living up to their promise of a few weeks ago.

Retail Manager Coughlin is predicting what a sensation he is going to make when he reports his sales of electric machines under the new price-list. The motor, he says, is a decided help in selling higher priced models. His chief worry is the limited supply of small machines for the spring trade, when the low priced machines are in best demand. Owing to floods in this district late last fall and during the winter, there is going to be a good deal of refurnishing of club and boat houses, and the talking machine folk are expecting an unusual run for these goods this spring because the talking machine has become known as a necessity to a club house, especially since the dancing craze has so strong a grip.

But, after all, it is the record business that is making the studious men of the trade and of kindred trades think long and hard. They see in this business a steady, week in and week out, trade that is well worth going after. It is an admitted fact that some of the local piano houses that have ignored the talking machines all along are looking enviously on the line since they have seen what a nice record business means to a house, what it means to have a long string of customers coming in weekly and investing from 60 cents to \$5 a



The new TRITON No. 2

The enormous popularity of the Triton No. 1 came not alone from its surprising Tone and Compactness—but also because of its simplicity and Ready Portability—as a Companion in the Camp—on the Boat—on Auto Trips—and in Dancing Visits to friends who were without music. But we have had so many requests for a more Pretentious Phonograph for permanent location in the home—that we have produced the Triton No. 2.

RETAILS FOR \$15

It is equipped with the Celebrated Triton Motor—and the Famous Triton Sound Producer—together with our new departure in arranging the Sound Chamber. Housed in a substantial Cabinet—finished in either oak or mahogany—not treated as so many cabinets are—to just a coating of coach varnish—but each cabinet is Hand Polished and Hand Rubbed—making a finish fit to associate with the best furnishings.

We have so arranged our Sound Chamber that the most Accurate Reproductions of the Artists' rendering are given to the record being played. The Pleasing Simplicity of the Cabinet is Accentuated by the Soft-Smooth effect of the finish. Together with this is accompanied the Strong Guarantee of all Triton Productions.

The Retail Price—\$15.00—has been made to conform with the Popular Demand.

Sample machine sent for \$7.50.

TRITON PHONOGRAPH CO. 41 Union Square
NEW YORK

Guaranteed
For 1 Year

We guarantee you against
legal complications.

week. It is predicted that at least two piano houses that have heretofore ignored the talkers will be advertising at least one make of machines by next Christmas. During the last few weeks one piano house that has handled talking machines in an indifferent manner for two years and has ignored the record business has set about stocking the Edison line of records in amounts that will enable it to meet all ordinary demands, and is advertising for record business more strongly than it ever has advertised for talking machine business.

Indeed, the announcements of new lists of records are becoming quite an advertising event. All of the department stores and five or six piano houses advertise the new records of the makes they handle in liberally spaced ads until everyone who reads newspapers must realize that talking machine records mean a great deal. Some extent of the business in St. Louis may be judged by a statement of one wholesale manager of a local house, who said that his "hang-over" orders at the factory recently have averaged 22,000 records.

The Silverstone Music Co. recently asked the buyers of the Edison disc records to vote on the approval privilege extended. The letter explained that the company was installing five new demonstration rooms, and that every convenience would be extended to those wishing to hear the records there. A letter was prepared early in the month stating that the result of the vote was that 3,628 persons had voted for the privilege of having records for twenty-four hours on approval provided they retained 50 per cent. of those taken out and that 2,350 users had voted for "no exchange." As a result, the letter stated that the 50 per cent., twenty-four-hour custom would be continued.

The usual regulation in St. Louis, that approved by the Talking Machine Dealers' Association, is that the records can be retained for forty-eight hours, and that 25 per cent. must be retained. Recently the Stix, Baer & Fuller Drygoods Co., handling Victors and Edison disc machines, started to refuse any trial privilege, but although no loss of patronage was experienced the trial privilege was again resumed.

The Silverstone Co. has its five new demonstration rooms completed, and they greatly improve the appearance of the warerooms, although they are built as a second story of the demonstration rooms on the floor level of the main floor wareroom. They are reached by an easily ascended stairway and instead of dwarfing the other demonstration rooms, as feared, they rather create the impression of a larger room.

Mr. Silverstone did not attend the annual gathering of the Edison jobbers at the factory recently, and in his telegram of explanation he said, "If it is a boy, we will name it Edison." The reply received said, "Your excuse accepted, provided you do not let it occur again next year." In sending word to the jobbers that the boy had been named Mark Edison Silverstone, Mr. Silverstone wrote the chairman, "Mrs. Silverstone fully agrees and accepts the condition you placed upon my excuse."

C. W. Burgess, supervisor of the Central and Western zones for the Edison laboratories, recently was at the Silverstone warerooms getting some pointers.

One of the new Columbia dealers is the Walther, Wymore Furniture Co. at Columbia, Mo., who will install an exceptionally large and well fitted department. Another dealer who starts in well is the Crossin Pharmacy Co. at Eldon, Mo.

Manager R. H. Gordon, of the Pathephone Co., is in high spirits over the progress made by that company since the incorporation a month ago. His greatest trouble, he says, is keeping a stock of records to meet the demands of the trade in this district, which is outstripping all expectations in this regard.

Talking Machine Manager Staffelback, of the Hellrung & Grimm Furniture Co., the chief local retail outlet for the Pathé line, has been conducting his business in an open parlor, thinking that until the line was better established here he could better handle the trade in this way. Recently, however, he has been forced to conclude that demonstration parlors were a necessity. When he sent out the announcement of the last Pathé list of rec-

ords he was besieged by a crowd that overran his entire talking machine headquarters and kept his demonstration machine going overtime, leaving little opportunity to demonstrate any other records that customers might inquire for. Also, this interfered seriously with his machine sales and demonstrations. So he arranged to build a series of talking machine booths at once.

Some new ventures into the talking machine sales recently have been made by the Thiebes Piano Co., which is selling the Starr machine. F. Beyer & Sons, one of the old piano houses, has ventured into the talking machine field with the Corona. The Field-Lippman Piano Co. is making a showing with the Artophone, which is advertised as the "St. Louis-made machine." This machine, which is made by the Artophone Co., organized here by the Cone family, well known in the local piano trade, has been attracting much attention.

J. W. Milligan, an Edison disc dealer of Carbondale, Ill., was a caller at the Silverstone Music Co. here early this month, accompanied by his bride, this being the first stop on their honeymoon trip.

The Koerber-Brenner Music Co., Victor jobber, is a firm believer in the reports that this section of the country is set for a banner business season, which will include talking machines. Accordingly it has made all plans for a big season and is meeting demands made upon it in excellent manner. It is having a minimum of complaints of service, and finds its dealers loyal and ready to support its efforts to better the trade.

A PECULIAR ACCIDENT.

(Special to The Talking Machine World.)

BELOIT, WIS., March 6.—While waiting on a customer recently A. V. Lyle, the well-known piano and talking machine dealer of this city, suffered a peculiar accident. Mr. Lyle was selecting records for a demonstration when a twelve-inch record, placed in the cabinet without an envelope, rolled out and dropped on Mr. Lyle's toe, injuring that member so badly that an X-ray photograph was necessary. The fact that it was a Julia Claussen record has not diminished Mr. Lyle's admiration for that famous songstress.

A Trade Sensation

A Moneymaker for Dealers and Agents

**GENUINE CABINET
Talking Machine for
\$35⁰⁰ Retail**

Handsomely finished in Mahogany or Antique Ivory

Fully Equipped With Record Shelves

**PLAYS ALL
MAKES OF
RECORDS**

And all sizes up to twelve inch

Perfect Tone
Perfect Mechanical Construction
Perfect Cabinet Work

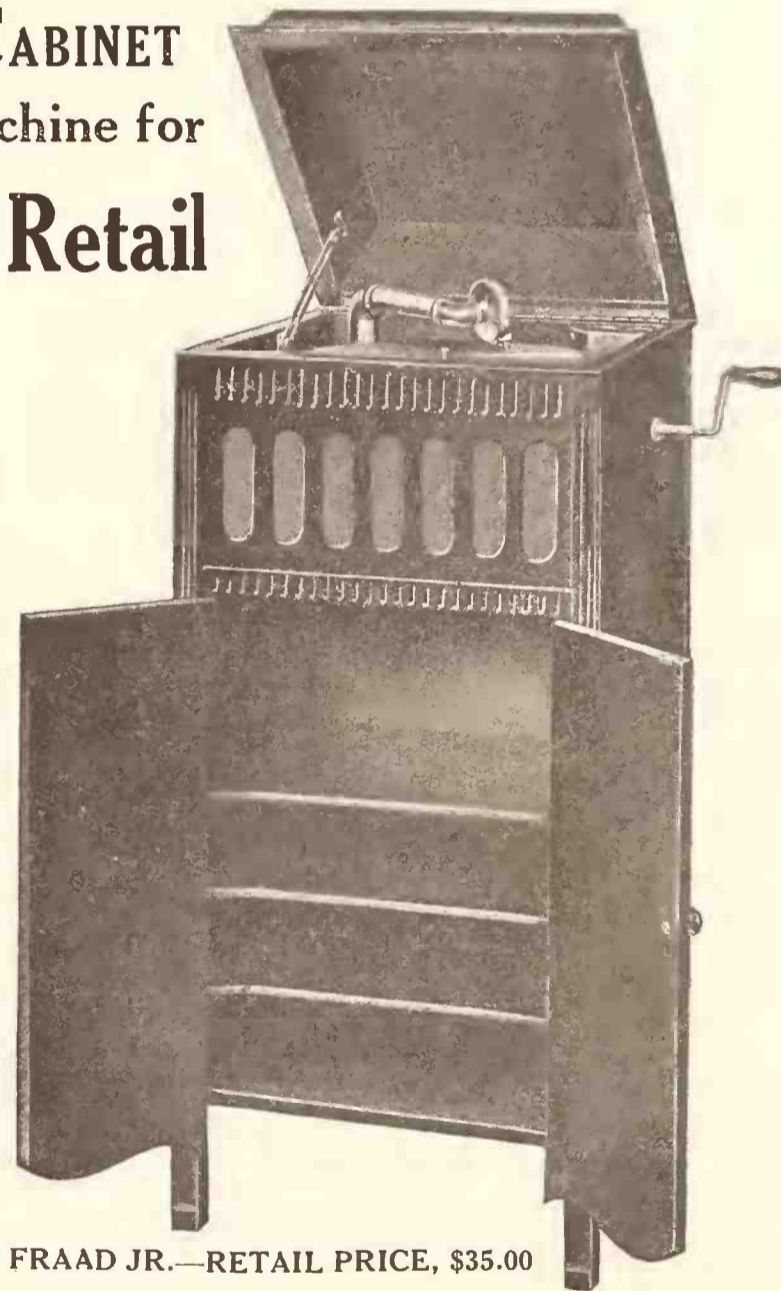

FRAAD JR.—RETAIL PRICE, \$35.00

OTHER STYLES and SIZES of MACHINES

FROM \$10 TO \$100

Send for Catalog and our Agents' Proposition—It Means Money to You

FRAAD TALKING MACHINE CO.

225
LEXINGTON AVE.

NEW YORK

Showrooms:
1160 BROADWAY



TONE ARMS, SOUND BOXES, ELBOWS, TONE ARM AND SOUND BOX ATTACHMENTS AND TONE ARM SUPPORTS OR BASES

may be die-cast by the Acme process, when used in quantities, giving you a beautiful and accurate product at less cost than if the same parts were made out of tubing or sand castings. The parts have a perfect finish and fit and are delivered by us unplated, but otherwise ready for assembly. We have had years of special experience in phonograph work, and will co-operate with you in the matter of design when desired. Submit models for estimate, stating quantities you will order.

ACME DIE CASTING CORPORATION
 Bush Terminal Building 5, 35th Street and 3rd Avenue
 Brooklyn, N. Y.

NOVEL VICTOR RECITAL ROOM.

Owens & Beers Give Demonstration in Cozy Room Underneath Their Main Floor.

The accompanying photograph, showing the recital hall in the establishment of Owens & Beers,



The Owens & Beers Recital Parlor.

New York, Victor dealers, is a fair example of what may be accomplished by up-to-date methods, even though floor space is at a premium.

The Owens & Beers recital hall, which comfortably seats about fifty people, although considerably more than this number are accommodated when the occasion requires, is located beneath the main floor of the store, and the furnishings and decorations are most refined.

Owens & Beers make a specialty of having popular Victor artists appear weekly at their concert hall and render a program of the songs which they have recorded for the Victor library. This program is interspersed with selections on the Victrola, the whole combining to make a very enjoyable afternoon's entertainment.

In front of each seat may be found a pad and pencil, and the auditors are given every convenience to jot down the record numbers of the selections on the program which they may desire to purchase or hear again when the concert is over. The concerts are absolutely free, and such well-known artists as Charles Harrison and Harvey W. Hindemyer have appeared during the past month. The results from this high-grade method of publicity have been re-

sponsible in a measure for the rapid growth of the business of Owens & Beers in New York and vicinity.

REALISTIC MUSIC ON PHONOGRAPH.

"The Pussy Cat Rag" Stirs Up Canine Anger—Collie Nearly Demolishes Machine In Frantic Attempt to Chastise the Felines.

W. H. Turner, a member of the firm of Pettibone Bros. Manufacturing Co., 626 Main street, Cincinnati, O., is the owner of an Edison Diamond Disc phonograph of which he is very proud.

Mr. Turner also has a very fine Scotch collie, wonderfully kind and intelligent. King (the collie) has a superabundance of canine aversion for cats and rats. One has only to say "Cat" or "Rat" in King's presence to make every hair on his back bristle.

Among the many Edison records in Mr. Turner's library is one entitled "The Pussy Cat Rag," which is full of catchy music. At one point in this record the words "Rats" and "Kittie" are pronounced very clearly and distinctly.

One evening not long ago Mr. Turner gave an informal Diamond Disc recital at his home to a number of friends and relatives, among them being a Mrs. B— Towards the close of the evening Mr. Turner, with the intention of giving his guests something a trifle more lively than the records he had been playing, started "The Pussy Cat Rag."

After it had been playing for a minute or so the basso said, very distinctly and clearly, "Rats," and the soprano replied equally distinctly and clearly, "Kittie, Kittie."

Just a moment later from another part of the house came a sound of scampering and barking and King, the collie, dashed down the steps to the reception hall, where the guests were seated. Barking loudly, King rushed across the room and made a leap for the phonograph from which came the basso's "Rats." Mrs. B—, who was seated nearest the instrument, made a grab for King and caught him by the tail, but not before the collie had pushed his paw through the grill and with one swipe tore aside the silken screen. King continued his frantic efforts to get at the rats and cats he supposed were inside the phonograph. All this time Mrs. B— bravely held to King's tail with an iron grip. Such a tug-of-war did it become between Mrs. B— and King's tail that many of the guests feared King's tail wouldn't hold out. Finally, Mr. Turner managed to drag the collie away from the phonograph.

Mr. Turner says that he will chain King the next time "The Pussy Cat Rag" is played.

Jacques Urlus, who sings for the Edison Diamond Disc exclusively, has found another great role in "Parsifal." He sang it for the first time at the Metropolitan on Washington's Birthday.

DO YOUR PART IN SUPPORT OF PRICE MAINTENANCE. GET IN COMMUNICATION WITH YOUR CONGRESSMAN AND SHOW HIM WHY THE STEVENS BILL WILL BE A PROTECTION TO THE PUBLIC AS WELL AS TO LEGITIMATE INDUSTRIES. DO IT NOW!

One to Five Thousand Dollars Extra Profits Will be Made by Dealers Who Sell Playerphones

The Playerphone sells from \$60 to \$160, comparing with other talking machines selling from \$75 to \$250. The Playerphone is a quality, popular price talking machine that will sell promptly when demonstrated to the best of trade. Our cabinets are superior, our motors and equipment first class. The Playerphone plays every record made without change of equipment. The Playerphone Talking Machine Company offers to Dealers terms which enable them to sell the instruments on easy payments and collect their money by the time they pay the Company, and make 100% profit. Dealers who order a sample Playerphone today and get in line for the agency of their locality will reap a harvest. Immediate action required.



PLAYERPHONE

Playerphone Talking Machine Co.

Suites 802-4 Republic Bldg.

CHICAGO, ILL.

Special proposition offered to Dealers who are in position to handle PLAYERPHONE from a jobbing standpoint. Excellent opportunity. Write immediately for particulars.

COUPON

PLAYERPHONE TALKING MACHINE COMPANY,
 Suites 802-4 Republic Bldg.,
 Chicago, Illinois.

Gentlemen—We are interested in your Playerphones and would like full particulars and prices to be submitted to us at once.

NAME.....
 ADDRESS.....
 CITY.....
 STATE.....

INCORPORATIONS OF THE MONTH.

The Mel-o-Tone Manufacturing Co. has been incorporated with a capital stock of \$5,000 by James A. Harvey, V. B. Mays and E. Griffith Williams. The company's address is said to be 17 North Crawford avenue, Chicago.

The Masterpiece Talking Machine Co. has been incorporated with capital stock of \$10,000 to engage in the manufacture and sale of talking machines. J. Godfrey, S. Mandell and A. H. Figner are the incorporators.

The Supertone Talking Machine Co. was incorporated at Albany recently by Emanuel W. Gluckman, Nathan Weissman and Anna Benrens, of New York City. The new concern will manufacture talking machines, its capitalization being \$5,000.

The Central Pathé Phonograph Co., with a capital of \$20,000, has been incorporated at Chicago by Arthur J., Arthur D. and Harry K. O'Neill.

The Weber Talking Machine Co., which will deal in machines, records and accessories, has been incorporated by A. Oblo and J. H. and G. Weber, of 242 Keap street, Brooklyn, with an initial capital of \$5,000.

The Universal Phonograph Co., Hoboken, N. J., was incorporated the past month by the Secretary of State, Trenton, N. J., to engage in the manufacture of phonographs and phonographic supplies. The capital is \$125,000, and the incorporators are Fred Kraft, Minnie Kraft and Frederick Heffner.

The Lynn Sales Co. has been incorporated to deal in phonographs and supplies by E. C. Frankell, W. L. Wray and R. A. Brooks, of 177 Belmont avenue, Jersey City, N. J. The capitalization is \$20,000.

The Phonograph Co., of New England, capitalized at \$25,000, has been incorporated at Boston.

The Riley Talking Machine Co., of Utica, was incorporated by Caroline, Sarah H. and George F. Riley, to deal in talking machines and accessories. The capitalization is \$5,000.

The De Loache Phonograph Corp., of Dallas, Tex., recently incorporated with a capital stock of \$10,000. The incorporators are: Ira De Loache, B. W. Carrington and D. W. Marshall.

The Stern Talking Machine Co., of San Francisco, Cal., was recently incorporated by F. Stern, J. Stern, J. G. Sweet, D. Hadsell and M. Duffy. The capitalization is \$50,000.

The Photoplay News Publishing Co., of Rochester, has been incorporated, with a capitalization of \$8,000. The company will manufacture talking machines and records. The directors are Leo Bernstein, Bernard Habner and S. Sellinger.

The Tiffany Phonograph Co., of Englewood Cliffs, N. J., was incorporated at Camden, N. J., last week, with a capitalization of \$5,000.

American Talking Picture Machine Corp., capital \$6,000,000, to manufacture talking machines, picture machines and records for same, was incorporated in Delaware this week. Local Wilmington, Del., incorporators are: Herbert E. Latter, Norman P. Coffin and Clement Megner.

The Ford Talking Machine Co., of Baltimore, Md., has been incorporated with a capitalization of \$5,000. The new concern will deal in toys and talking machines.

Four modern demonstration rooms and a large recital hall form part of the equipment of the Malley talking machine parlors in New Haven, Conn. Both the Edison and Columbia machines and records are carried.

The Cornish Co., of Washington, N. J., is about to engage in the manufacture of talking machine cabinets in partial substitution for the organs formerly manufactured.

TALKER THRILLS FIRE FIGHTERS.

Machine in Burning Store Starts Going and Gets Rescuers All Excited, It Appears.

The following thriller comes to The World under a San Francisco date line. The story is almost new:

At a recent fire in a business house at Hanford, Cal., the fire fighters and spectators were startled to hear a man singing in the midst of the flames. It was evidently impossible for rescuers to reach the spot, so several streams of water were concentrated around the source of the sound. The singing then stopped, but the firemen made their way into the building as quickly as possible, expecting to find a charred body. They were not a little chagrined to discover that the song had proceeded from a talking machine, which the heat had apparently set in motion, but had been stopped when the water struck it.

Success comes only by working for it—never by shirking for it.

Jewel Needles

DIAMOND, SAPPHIRE, AGATE

For All Types of Records

Our methods of grinding needles are the most scientific known, producing a most uniform and highly polished product.

We manufacture ALL parts of Talking Machines

DIXON MFG. CO., Inc., 295 5th Ave., New York

SECURES NEW YORK FACTORY.

The Supertone Talking Machine Co., which was recently incorporated, has secured a factory at 18, 20, 22 West Twentieth street, New York. The head of the company is C. J. Kronberg. The company will make a line of machines from \$10 to \$100.

Announcement of the

PATHEPHONE SALES CO. OF NEW YORK

(Owners: BRISTOL & BARBER)

111 E. 14th Street, N.Y., (next to Steinway Hall)

Pathé Distributors

DEALERS will be glad to know of the establishment of our concern, for it means a new era in Pathé Service for those in this territory.

Our endeavor at all times will be to work *with* the dealer; to see that he not only has co-operation from his selling end, but that service on machines and records will be practically complete.

There will be a tremendous increase in the sale of Pathephones in this territory, and we would urge dealers to discuss the unlimited possibilities of this line with us.



Pathephone Sales Co.
of New York

(Owners: BRISTOL & BARBER)

111 East 14th Street, New York

(Next to Steinway Hall)

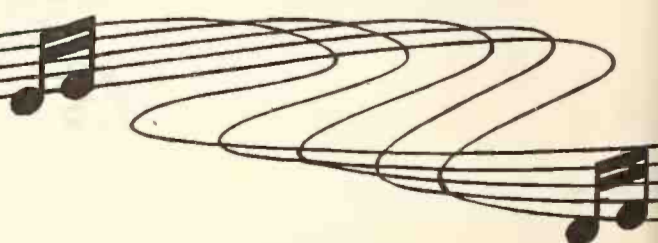

What's behind the notes?

Quality!

Tone quality in the producing construction of the Columbia Grafonola—in every part from needle-arm to the control “leaves” at the front.

Quality in design of cabinets and in the workmanship that follows the design.

Tone quality in the Columbia records that are bought to play on it—tone quality so absolutely superior that at least fifty per cent. of your customers know all about it.

Fair dealing!

Progressiveness in manufacture and broadness in appreciation of the dealer's needs and problems, and of the dealer's point of view.

That's what's back of this most significant trade-mark in the musical world!

Columbia Graphophone Co.

Woolworth Bldg.

New York City





TRADE
Victor-Emerson
MARK

EVERYONE

Can Afford a

RETAIL **\$3.00** PRICE

EMERSON PHONOGRAPH

A practical talking machine, with sound reproduction equal to many higher priced machines. Plays any disc record without an attachment, and a 12-inch record with one winding.

Solid wood case, oak finish; size $9\frac{1}{2} \times 9\frac{1}{2} \times 12$ "; weight packed, $8\frac{1}{2}$ lbs.; unpacked, $6\frac{1}{2}$ lbs. Completely equipped, no extras. Guaranteed. Easily carried. Great for outings.

BE AN EMERSON DEALER

You can sell the Emerson to thousands who have had to deprive themselves of a talking machine because of the high prices.

You will sell twenty "Emersons" while other dealers are selling one expensive phonograph. A demonstration—the price—the sale is made.

Every machine sold means a steady customer for "Emerson" 10c and 25c records. The Emerson repertoire includes records by famous Artists for 10c. That's only one feature of this wonderful line.

You will say that we have the "Ford" of the phonograph business when you see and hear the "Emerson."

Write for proposition to trade on "Emerson" Phonographs, records, needles, record albums, record repeaters, sapphire needles, carrying cases, etc.

SPECIAL—If you are now selling other talking machines, we have no objections to your also selling the Emerson. If you can't do it in the same department, put the Emerson in some other department, in the basement, anywhere you please.

JOS. W. STERN & CO. SALES CORPORATION

DISTRIBUTORS OF
EMERSON PRODUCTS

107 West 38th St., New York City

JOBBER VISIT VICTOR FACTORY.

Committee Representing National Association Calls to Discuss Business Problems.

At the meeting of the executive committee of the National Association of Talking Machine Jobbers held in New York last month a sub-committee was appointed to visit the factory of the

Victor Talking Machine Co. in Camden, N. J., and confer with the officials of that company regarding general matters of trade interest. As is always the case, the committee was cordially received by the factory officials and much good was accomplished by the visit. The jobbers' committee included E. C. Rauth, J. N. Blackman, W. H. Reynolds, H. A. Winkelman, G. E. Mickel, J. C. Roush and Charles F. Bruno.



Committee of National Association of Talking Machine Jobbers Photographed at Victor Factory on February 17—Standing, Left to Right—E. C. Rauth, J. N. Blackman, W. H. Reynolds and H. A. Winkelman—Seated, G. E. Mickel, Jos. C. Roush and Chas. F. Bruno.

CLOSED SOME BIG ORDERS ON TRIP.

Thos. F. Walsh, secretary of the Union Specialty & Plating Co., Cleveland, O., was a recent visitor to New York, and in a chat with The World reported a remarkable demand for the specialties turned out by his house. On his present trip he booked the largest business he ever transacted. The growth in demand for the talking machine specialties made by this house has been so continuous that larger manufacturing quarters are necessary.

"We have won the confidence of the trade," said Mr. Walsh, "because we have aimed to give the best of values in our products, and this has been appreciated by manufacturers who have steadily increased their orders."

AGE NO HANDICAP.

When you feel disposed to think that age unfits a man for work, watch how the old tar stands hardships that kill the young seaman, and behold how the gray heads do the great business of the world.

The Burtclay Phonograph Shop has opened very attractive quarters at Bergen Square, Jersey City Heights, N. J.

MEETING A GROWING DEMAND.

Various Models of Fraad Talking Machines Selling Well—The Fraad Junior Style Is in Particular Demand with the Trade.

The Fraad Talking Machine Co., 1160 Broadway, New York, reports a most satisfying demand for the various machines in its well-balanced line, with particular interest being shown by the trade in the Fraad, Junior, full cabinet machine, selling at retail for \$35. The Fraad, Junior, is equipped to play all sizes of records up to and including twelve-inch, and the cabinet is supplied with shelves for the filing of a large number of records.

At the present time the Fraad Co. is in a position to meet promptly all demands for machines, having a large and varied stock on hand and within a week or so the factory of the company will have caught up with the demand for the Junior model and be able to supply that model promptly and in quantities as desired.

During the past month or so the Fraad Co. has added a large number of new agencies to its list, and has made a number of important exclusive territory arrangements, one of them taking in a large part of Western Canada, where there is already a good demand for the Fraad line.

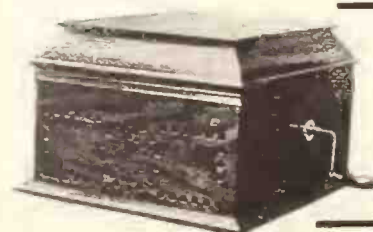

HARPVOLA

Price \$11.50

DISTRIBUTERS WANTED

HARPVOLA TALKING MACHINE CO.
Harrisburg, Penna.

ADVERTISING A BIG FACTOR

In Maintaining Trade and Prestige in Public Mind—Victor Policy Highly Commended.

In an interesting article entitled "Advertising When the Factory Is Oversold," which appeared in a recent issue of *Printers' Ink*, S. C. Lambert cites the Victor Talking Machine Co. as an ideal example of the modern business institution which has the foresight and courage to continue an advertising campaign when its output is far over-sold. After calling attention to the fact that a consumer very often gets the impression that a business is not what it used to be because of a cessation of advertising, Mr. Lambert said in part: "The consequence is that, instead of maintaining admitted leadership, the concern may have to drop back on a level with its competitors, or perhaps even be content with second place.

"Rather than let that happen, concerns like the Victor Talking Machine Co. are wise enough to invest a share of their profits in maintaining their standing in the trade and their prestige in the public mind. They do not need orders at the moment, but they *do* need the confidence of the people. An increase in orders may be a temporary embarrassment, but an increase of public confidence can never be anything but an asset.

"I believe the Victor Co. is one of the many concerns which include in their balance sheet the following item: 'Patents, trade-marks, good will, etc., \$1.' That, of course, is only a convenient and conventional method of indicating that the assets included in the list are valuable, although the company doesn't choose to estimate their value in definite terms. I have seen the Victor Co.'s trade-mark 'valued' in conversation at anywhere from \$1,000,000 to \$10,000,000.

"Of course it is obvious that the trade-mark has no value whatever apart from the business which it represents, and even in connection with the business it has a value only to the extent that it is known and recognized. It is the 'commercial signature' of the company, and, like any individual signature, it is worthless unless it is recognized as genuine. A concern which deals with the public—directly or indirectly—can as little afford to permit its trade-mark to be forgotten as it can afford to let doubt be cast upon its credit."

HOW TO HEAR MUSIC INTELLIGENTLY.

School of Fine Arts, U. of A., Offers Free Course in Music to Any School or Club.

(Special to The Talking Machine World.)

FAYETTEVILLE, ARK., March 10.—The School of Fine Arts of the University of Arkansas is sending to any club or school in the State four sets of fifteen talking machine records each, which are sent out to aid "intelligent listening to music," which is encouraged by the School of Fine Arts. Each set of records is accompanied by a type-written "talk" explaining the music and giving facts regarding its origin, the instrument and singers.

The records can be used on any Victrola talking machine and can be secured free of charge by any school or club.

FEATURING STEWART PHONOGRAPH.

The Stewart Phonograph Co., Chicago, Ill., carried a full-page advertisement in last week's Saturday Evening Post to announce to the general public the Stewart phonograph which retails at \$5. This advertisement presented a number of effective selling talks, which pointed out the numerous constructional features of the Stewart phonograph, emphasizing the fact that it is equipped to play all makes of records and is finished in solid, dull-black metal with highly polished nickel-plated trimmings.

One section of the advertisement called attention to the prominence of the Stewart name, stating: "The Stewart name is established all over the world. Millions of dollars are back of it. Stewart products are found on practically every automobile. Everyone knows the Stewart speedometer, the Stewart tire pump, the Stewart vacuum system. It is estimated that 95 per cent. of all automobiles carry one or more Stewart products."

THE MOST MOMENTOUS FACTOR.

"Let us pause in our admiration for the automobile, in our delight in the moving pictures and in our awe of engines of war to consider the fourth most momentous factor that has been introduced into modern life—the recording and reproducing music machines," says the Detroit Journal in a recent editorial.

"What an enormous factor they have become in life. More than one per minute is sold to American homes. The auto, the talking machine and the 'movies' have become necessities. And of the three the talking machine is perhaps giving a higher and better form of intense enjoyment to millions.

"Some musical exclusives affect to despise what they think is the talking machine, having heard one once ragging the scale at a country fair. But gradually each of the most keenly sensitive critics of music succumbs to the magic spell of the high-class record, and they realize that they are in the presence, not of a slap-bang, wang-dang infernal nuisance, but of an instrument as revolutionary in cultural life as anything since the invention of printing."

VICTOR-CHENEY HEARING SET.

(Special to The Talking Machine World.)

CHICAGO, ILL., March 13.—Federal Judge Carpenter has set April 24 as the date for hearing the case of the Victor Talking Machine Co. versus the Cheney Talking Machine Co. The court has received and is examining depositions made by experts at Philadelphia and at Chicago, and after hearing orally from additional witnesses, will give his decision. The matter will not necessitate more than two or three hearings, it is said.

U. S. MAKING INDIAN RECORDS.

(Special to The Talking Machine World.)

WASHINGTON, D. C., March 10.—The United States Government is endeavoring to retain for future generations the voice and songs of the American Indian, and talking machine records of the songs and conversation of prominent Indians are being made. The work of making the records is being done by officials of the Smithsonian Institute, and several Indians have been brought from Western reservations to Washington for the purpose of making the original records.

Arithmetic

It costs you so much for rent, bookkeeping, clerical help, light, delivery, selling, advertising, collecting and incidentals.

What you have left over is **YOURS.**

It may be enough for a Ford or a Fiat.

Most of the expense is **FIXED**—you cannot lower it. The only thing you can do is to **INCREASE** the **INCOME.**

How?

Phonographs? You're doing almost as much as you can for the size of the city.

Records? Doing a good business but clerks not always busy.

Cabinets? Maybe you didn't think of **SELLING** cabinets before. **20%** increase in cabinet sales will show an amazing profit. Sell Herzog Cabinets; well-made; piano finish; well designed; strong; sold at a reasonable price; made for all machines.

Write to-day and get the complete Herzog story, together with a copy of the greatest cabinet catalog ever issued.

DESIGNING SERVICE.—We are designers and builders of talking machine and music cabinets of all kinds. Our corps of expert designers is at the command of any manufacturer or dealer, and this staff will gladly submit original models. Simply give us an idea of the price that you wish to meet and the number wanted, together with any other data that will help us to give you our best efforts.

Ask for Copy Catalog "H"

Herzog Art Furniture Co.

Saginaw, Mich.

NEW COLUMBIA FACTORY COMPLETED THIS MONTH.

Most Modern Construction and Equipment Represented in the New Plant of the Columbia Graphophone Co. in Bridgeport, Conn.—120,000 Square Feet of Floor Space Available.

The Columbia Graphophone Co.'s new factory building at Bridgeport, Conn., the structure of which was completed this month, will be one of the best-equipped and most up-to-date manufac-

under ideally pleasant and congenial conditions 47,000 square feet of window glass were installed. There is plenty of light on all floors and on all sides of the new building, and indeed every known modern convenience for the employes has been installed in this Columbia factory.

On the first floor of the factory will be installed a metal-pressing department; on the second the automatic screw machines and drilling department; on the third, hand-screw and milling machines; on the fourth, electric motors, electric graphophone assembling department, mechanical drafting rooms and laboratories. The executive offices will occupy

GOOD DEMAND FOR LANSING COVERS.

Dealers Appreciate Value of Having Machine Delivered in Perfect Condition.

E. H. Lansing, manufacturer of the famous Lansing khaki moving covers, was in New York the past week in the interests of his products.



Laying the Foundation.

turing plants in Bridgeport—a city which is recognized as having some of the finest factories in the country.

The contractors who built this new factory established an enviable record for speedy construc-

the fifth floor, and the polishing and buffing department the sixth.

One of the most interesting features of the equipment of this new factory will be the installation of several systems which will tend to greatly enhance the efficiency of routine factory system. The work will be laid out in such a manner that waste time and motion will be practically eliminated, and several new ideas in various departments will be introduced.

All the products of the plant will be handled by a most up-to-date conveying system, which will be particularly adaptable for use in this new factory. In addition to the passenger elevator there will be two large freight elevators, and another time saver will be a pneumatic tube system for sending small tools from the tool room to various parts of the plant. Pneumatic tubes will also be used to convey

departmental and inter-departmental correspondence, orders, etc.

The company has adopted a new plan in installing its polishing and buffing department on one of the upper floors of the building. This will keep the dust from this department away from the other divisions, and the huge suction blowers for ventilation, which change the air in this room once every two minutes, will force the dust out into the upper air instead of near the ground, where it would rise and be wafted into other rooms.

So efficiently has the factory been planned that many manufacturers have visited the new plant seeking for ideas which might be incorporated into other factories in Bridgeport which are being remodeled and enlarged. In addition to the increased output which the factory will afford, the practical and efficient methods of manufacture which are followed will result in reducing to a minimum the overhead charges and costs of manufacturing.

Among the recent Edison tone tests given in the East was that held at the Sterling Theatre, Derby, Conn., where over 800 people braved a storm to hear Miss Helen Clark match her voice with the Edison Diamond Disc phonograph and records. Arthur L. Walsh, a violinist from the Edison laboratories, also appeared in the recital. Albert H. Yudkin is the Edison dealer in Derby.

Do you expect to see prosperity come in like a freight car loaded with gold nuggets, mined by someone else for your special benefit? You will surely be disappointed.

SPOT CASH paid from 20 per cent. to 60 per cent. for any quantity or make of used phonographs and records. State price and make. Address "Box 304," care The Talking Machine World, 373 Fourth Ave., New York.

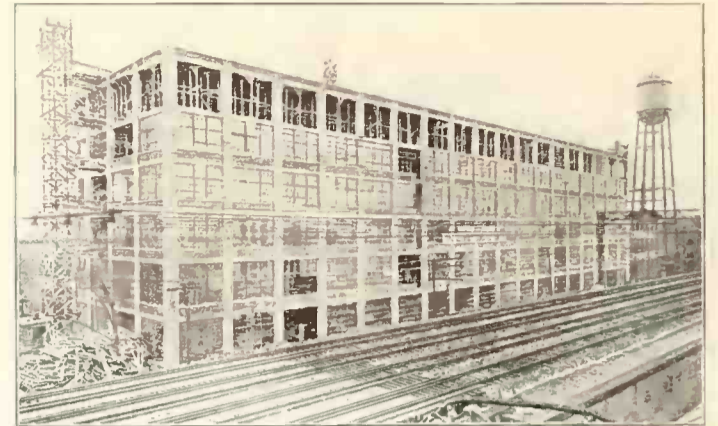

Five Floors Enclosed.

Mr. Lansing reports excellent demand for his goods, and stated that dealers everywhere are realizing the value of shipping finely polished cabinets in such a manner that the goods will arrive in the same excellent condition that they leave the polishing-off department.

Henry Lobschutz and Herman Segal, formerly associated with the Symphony Talking Machine Co., have formed a co-partnership under the firm name of the Mutual Talking Machine Co., and will manufacture machines retailing from \$10 to \$100.

The Elginola Talking Machine Co., of Milwaukee, was incorporated this week with a capitalization of \$10,000. The incorporators were: Frank Rose, Albert Salomon and S. R. Simon.

WORLD'S CLASSIFIED ADVERTISING

Any member of the trade may forward to this office a "Situation" advertisement intended for this Department to occupy a space of four lines, agate measure, and it will be inserted free. Replies will also be forwarded without cost. Additional space will be at the rate of 25c. per line. If bold faced type is desired the cost of same will be 25c. per line. Business opportunities 25c. per line.

MANUFACTURING POSITION WANTED—

Thoroughly experienced man capable of putting in complete plant for manufacturing vertical cut disc records. Can make the finest master wax. Experienced in latest recording methods. A specialist in electrotyping and backing matrices. Extensive general manufacturing knowledge. Can systematize plant and make eight-inch disc to wholesale for eleven cents, process complete; no experimental work necessary. Can adhere to advance estimates. Address "Box 308," care The Talking Machine World, 373 Fourth Ave., New York City.

SPACE FOR RENT! Will rent space in my jewelry store twenty-five by seventy-five to live man, splendid location for Victrola shop and record exchange on North Woodward Ave., 1 1/4 mile circle, Detroit, Michigan. Address "Box 313," care The Talking Machine World, 373 Fourth Ave., New York City.

SUPERINTENDENT, FOREMAN OR EXPERIMENTAL MAN—Practical machinist and instrument maker, age 39, possessing executive and inventive ability and a thorough knowledge of spring motors, sound boxes, etc., and all the manufacturing details connected with the low cost production of same, seeks position. Could bring in exclusive patented side line if desired. Address "Box 309," care The Talking Machine World, 373 Fourth Ave., New York City.

A FIRST-CLASS VICTROLA REPAIRMAN, with 15 years' experience in the talking machine business, competent to take charge of any talking machine factory or Victrola department, desires position with a reliable firm. Will go anywhere. Best of references. Address "Box 314," care The Talking Machine World, 373 Fourth Ave., New York City.

ARE YOU LOOKING FOR ME? Wideawake talking machine manager and salesman with 10 years' experience in all makes, prefer Edison line. Experienced window trimmer of proven results; best of references. Answer quick if it is a real manager you want. Address "Box 315," care The Talking Machine World, 373 Fourth Ave., New York City.

LINE WANTED.—Man of long experience and acquaintance with trade wants good line of talking machines to handle in Chicago and West. Have office and all facilities. Address "F. E., 10," care The Talking Machine World, 220 So. State St., Chicago, Ill.

YOUNG LADY, age 25, with 10 years' experience, as manager in talking machine department, wishes connection with reliable concern; salary no object to start. Best of references. Address "Box 316," care The Talking Machine World, 373 Fourth Ave., New York City.

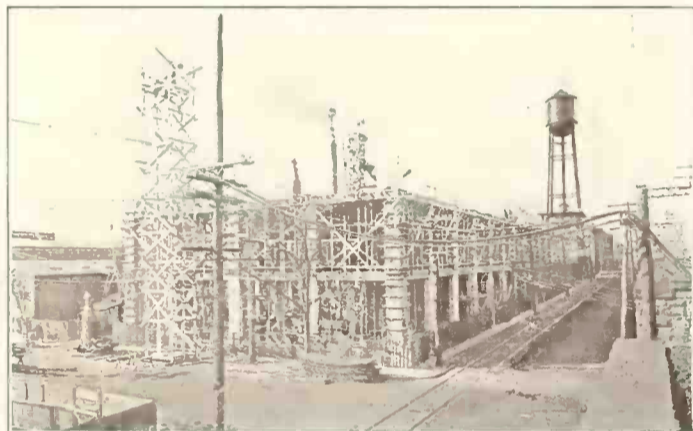

Two Stories Up.

tion work. The foundation for the new building was laid on October 11, 1915, and in a period of only four months the building was erected from cellar to skylight. The accompanying picture will show by dates the rapid strides made in the construction of this building, and neither expense nor



After a Snow Storm.

effort was spared to make this factory thoroughly representative of the Columbia Graphophone Co.'s prestige in the talking machine field.

The new Columbia factory building is an immense plant in every particular. It contains approximately 120,000 square feet of floor space, and in order that the employes may be able to work

Remarkable Opportunity

for one with moderate capital to engage in manufacture of talking machines. Big and increasing shortage in present market. Machines can be profitably made in factory fully equipped all ready to start. Location and every facility for most economical production, with lowest transportation cost and quick delivery. For sale at a bargain. Large profits, ready market, prompt returns.

ADDRESS :

"Trustee": Box 37, Wilkes-Barre, Pa.

FROM OUR EUROPEAN HEADQUARTERS

2 GRESHAM BUILDING, BASINGHALL STREET E. C., LONDON, W. LIONEL STURDY, MANAGER.

Government Embargo on Cabinet Woods Offers the Final Blow to Talking Machine Manufacturers, Already Heavily Handicapped by the Shortage of General Supplies and of Capable Workmen—"Talkers" Considered as Necessity Rather Than Luxuries—Lieut. E. B. Samuel Killed in Action—Musical Goods in Prize Court—Price-Cutters Restrained—Record Makers Working Hard—Associated Copyrights, Ltd., Organized—Lord Mayor of London Makes Record for Columbia—News of the Month in Detail.

(Special to The Talking Machine World.)

LONDON, E. C., February 29.—Throughout the whole music trade field there is a growing strong adverse atmosphere which overshadows all previously experienced difficulties within memory. Beset with this and that restriction, the future good welfare of the industry bids fair to suffer undue hardships. To successfully overcome first, the almost total extinction of supplies of machines and parts; second, the increasingly great dearth of labor; is in itself an achievement worthy of emphasis as an example of British tenacity and enterprise. But a new element has come upon the scene in the issuance of an official rescript prohibiting, except under license, the importation of furniture wood, hardwood and veneers. This is regarded by gramophone men very seriously—it knocks the bottom out of the trade boat altogether. While there may be felt no very great shortage at the moment, prices have already gone up over 100 per cent., and it is certain the new policy will rush the figure up alarmingly quick. Through this action the Government expects to suppress to a great extent the making

of furniture, pianos, gramophones and other musical instruments. Doubtless their aim will be achieved, for with the lack of wood and the upward tendency of prices, it will not pay to produce musical instruments. So serious is the position regarded that prominent members of the trade immediately convened a meeting whereat it was decided to approach the president of the Board of Trade and lay before him the hardships that would be inflicted upon our industry. It was rightly asserted that the gramophone trade might reasonably be regarded to-day not as a luxury so much as a necessity for, during the whole course of this war, mechanical music has provided broadly speaking, the only possible entertainment to the toiling millions who have little or no time for outdoor pleasure; to our wounded lads in hospital; to soldiers at the base and at the rest camps; to isolated garrisons; to our sailor boys ashore and afloat; and in a hundred-and-one other directions. Unmoved by the trade's exportations, the Government has decided that the gramophone business can be dispensed with, and the matter ends. Meanwhile ways and means will doubtless be found to continue as far as may be possible the output of instruments. Very few are constructed in England to-day; most are assembled here from imported parts, aside from the substantial number of complete machines received from America.

Fair Showing Made with Records.

On the record side, trade is making a very fair showing. It would be greater were sufficient labor obtainable. As it is, dealers cannot keep much of a stock, for as quickly as replenished, it is sold out. New recordings are not so noticeable these days. The big companies are keeping up a

goodly standard of new issues, but I observe that the smaller firms are content to issue only about half their normal monthly programs of new selections. This is all that is possible with depleted staffs, having regard also to the necessity of completing orders for standard repertory songs and instrumental numbers, for which there is always a satisfactory demand.

Apart from the trade press advertising, a fair amount of gramophone publicity is carried by the popular newspapers and magazines. The firms chiefly in evidence are "His Master's Voice," Columbia, and Pathé Frères, who continue to make a strong advertising appeal to the great talking machine public.

Lieut. Edgar B. Samuel Killed in Action.

It is with deep regret that I have to announce the death, in action, of Second Lieutenant Edgar Barnett Samuel, Sixteenth Battalion Middlesex Regiment. A sympathetic letter from the commanding officer speaks in high words of praise of Mr. Samuel's bravery—almost to recklessness—and of his ever courageous example under the varying fortunes of war. The deceased officer is mourned by a host of trade friends, many letters of sympathy having been received by Barnett Samuel & Sons, Ltd.

The late Mr. Samuel was the elder son of Mr. and Mrs. Nelson Samuel, to whom, in their great loss, The World tenders its respectful condolence. For many years the deceased took a keen interest in the welfare of the working lads of the East End of London, and was actively associated with the work of the Jewish Lads Brigade. On the outbreak of war he joined up as a private and was promoted in turn corporal and sergeant, re-

(Continued on page 50.)

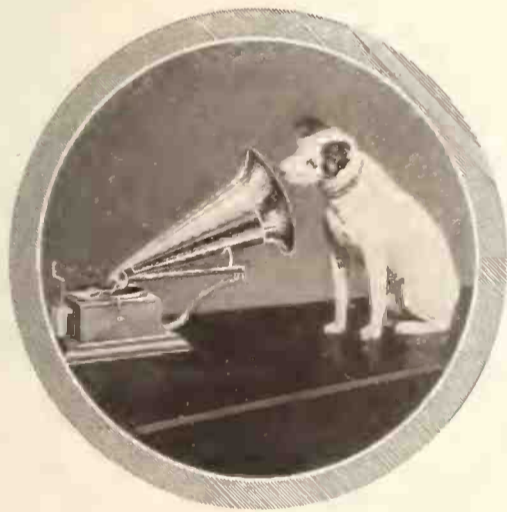

"His Master's Voice"

Copyright

This intensely human picture stands for all that is best in music

—it is the "His Master's Voice" trade-mark, and it brings to you, no matter where you are, the very best music of every kind, sung and played by the world's greatest artists—the greatest singers, pianists, violinists, orchestras and bands—all enshrined in the unequalled "His Master's Voice" records

'His Master's Voice'

—the trade-mark that is recognized throughout the world as the

HALL-MARK OF QUALITY

Branches

DENMARK: Skandinavisk Grammophon-Akti-
eselskab, Frihavnen, Copenhagen.

FRANCE: Cie. Française du Gramophone,
115 Boulevard Richard Lenoir, Place de la Ré-
publique, Paris.

SPAIN: Cia. Francesca del Gramophone, 56,
Balmes, Barcelona.

SWEDEN: Skandinaviska Grammophon - Ak-
tiebolaget, Drottning Gatan No. 47, Stockholm.

RUSSIA: The Gramophone Co., Ltd., 45, Nev-
sky Prospect, Petrograd (Petersburg); No. 1
Solyanka, Solyanoi Dvor, Moscow; 9, Golo-
vinsky Prospect, Tiflis; Nowy-Swiat 30, War-
saw; 33, Alexandrowskaya Ulitsa, Riga; 11
Michailovskaya Ulitsa, Baku.

INDIA: The Gramophone Co., Ltd., 139, Bal-
liaghatta Road, Calcutta; 7, Bell Lane, Fort,
Bombay.

Great Britain:

The Gramophone Company, Ltd.

HAYES - MIDDLESEX - ENGLAND

Agencies

AUSTRALIA: S. Hoffnung & Co., Ltd., Sole
Concessionaires of The Gramophone Company,
Limited, 163, Pitt Street, Sydney.

NEW ZEALAND: Gramophonium, Ltd., 118-
120 Victoria Street, Wellington.

SOUTH AFRICA: Darter & Sons, Post Box
174, Capetown; Mackay Bros., Post Box 251, Jo-
hannesburg; Mackay Bros. & McMahon, Post
Box 419, Durban; Ivan H. Haarbarger, Post
Box 105, Bloemfontein; Franz Moeller, Post
Box 108, East London; B. J. Ewins & Co., Post
Box 86, Queenstown; Handel House, Kimberley;
Laurence & Cope, Post Box 132, Buluwayo; The
Argus Co., Salisbury.

EAST AFRICA: Bayley & Co., Lourenzo
Marques.

HOLLAND: American Import Co., 22a, Am-
sterd Veerkade, The Hague.

ITALY: A. Bossi & Co., Via Orefici 2, Milan.

**EGYPT (Also for the Sudan, Greece and the
Ottoman Empire):** K. Fr. Vogel, Post Box
414, Alexandria.



We do not rely on giant advertisements for Sales—We depend on intrinsic Merit alone.

No amount of advertising can increase the value of

WINNER RECORDS: ("The World's Super-Disc")

They outwear all others.

Only up-to-date songs and selections recorded.

Winners leave the dealer a generous margin of profit.

THEY SELL ON THEIR MERITS

Independent LIVE REPRESENTATIVES WANTED—in U. S. and British Colonies

Write the manufacturers for Trade Terms

THE WINNER RECORD CO., Ltd.

Willowbrook Grove, Camberwell, London, England

FROM OUR LONDON HEADQUARTERS—(Continued from page 49).

ceiving his commission last March. He lost his life while out on night patrol duty in France, in performance of his duty to the last.

Musical Goods in Prize Court.

At Liverpool recently the cargoes of several prize ships were sold by auction. Among the various lots catalogued were to be noted gramophones and fittings, organs, mouth organs, accordions and similar musical instruments. Will the absence of these musical charms tend to prolong the combatant spirit of our enemies?

Fire Causes Little Damage.

My January issue report of the fire at W. M. Still & Son's Charles street premises has evoked a letter from that company which will remove any misapprehension as to their ability to carry on as before. It is, in part, as follows: "We are very pleased to say that our machinery has suffered very little damage, and the loss of stock is comparatively small when taking into consideration the very heavy stocks that we carry. Fortunately, we were able to secure temporary premises directly opposite our old factory, where we have installed our machinery and are carrying on, but unfortunately we have been able to give very little attention to the manufacture of gramophone horns just lately owing to us having placed our resources to the execution of far more important work."

A Trade Commissioner from Australia.

The Board of Trade announces that G. T. Milne, British trade commissioner for Australia, will arrive in London next month (March), and may be consulted by traders with reference to business conditions in the commonwealth. Firms desirous of an interview should make application to Commercial Intelligence Branch of the Board of Trade, Basinghall street, London, E. C. Mr. Milne's visit is particularly opportune at the present time, when British manufacturers are attempting to capture trade hitherto done by other

countries in Australia. He is prepared to give advice and information as to the appointment of agents, methods of marketing and distribution, terms of payment, names of probable buyers of British goods, statistics of imports, rates of customs duties, etc.

So runs the innocent official announcement to the press. It all reads very nicely, but one is tempted to inquire how a particular trade can develop export business if its very existence is threatened by government restriction as to the import and export of metal or wood vital to the manufacture of its products?

Columbia Co.'s Victory Over Price Cutting.

Once again the Columbia Graphophone Co. has established in the courts its patent rights against infringement by price-cutting. In this case a Gateshead dealer, G. B. Vanner, was found to be selling the plaintiff company's records at a less figure than the price stipulated thereon. He disregarded clear and sufficient warnings, and the Columbia Co. was therefore forced to sue in the protection of its patent rights. The matter was thoroughly thrashed out in court, and in an exhaustive judgment his lordship held that there had been an infringement. An injunction to restrain defendant from underselling the records was agreed to by the judge, with costs. The plaintiff did not ask for damages.

"Who's Who" on Winners.

Bearing the above inscription, a fine art-paper poster has been issued by the Winner Record Co. It presents characteristic portraits of a few of the famous artists who have contributed to the Winner repertory, and should prove alike valuable as an advertising window bill for dealers as of interest to private collectors of photos of record artists. A good idea well carried out!

Musical Instruments for the Army.

The War Office has recently accepted tenders for the supply of army musical instruments from

a number of well known British makers, who are under contract to deliver the instruments within a given time.

New Company Incorporated.

Tape Record, Ltd., capital £1,000. One of the objects of this company is to manufacture and sell records and instruments for producing sound and for recording sound waves, etc. The signatories are H. S. Johansson and E. J. Gladman, of Avenue Chambers, Southampton Row, London, piano manufacturer.

"Rollophone" Proves Popular.

The new instrument, styled the "Rollophone," recently marketed by W. H. Reynolds (1915), Ltd., of this city, has already won great popularity among the trade by reason of its excellent value and unique features of construction. A review of this new table-grand instrument was given in my last report, and dealers on the lookout for a live selling line should refer thereto for full particulars.

Sales-News from "His Master's Voice" Co.

The mere maintenance of its instrument and record output does not occupy the sole attention of the Gramophone Co., Ltd., as with some firms, to the exclusion of what is of equal importance—the sales question. Goods produced does not necessarily mean goods sold. Hence one may regard the sales ideas bureau of "His Master's Voice" as indispensable as the factory output. Owing to the adverse circumstances of production and consequent scarcity, instruments and records to-day do not require much selling; they sell themselves. But there is the spirit of progression ever present, and although this company finds itself almost unable to meet the heavy demands upon its resources, the constant stream of new selling ideas which it develops each month fully explains the reason thereof. Much care and attention was last month devoted to the inauguration of a Kirkby Lawn sales week, and its success has evi-

GUARDSMAN RECORDS. NEEDLE CUT.



Do You Know that we are manufacturing a Record which is superior to any expensively advertised brand that you handle at about half the cost?

We have 700 titles for you to select from, including all the latest up-to-date English and American successes.

Send for Catalogues, Trade Terms and Agencies to:

THE INVICTA RECORD CO., LTD., 1 New Inn Yard, London, E. C., England

FROM OUR LONDON HEADQUARTERS—(Continued from page 50.)

dently inspired another excellent scheme. This time it is a special concert week, during which dealers will feature a chosen program of "H. M. V." records and invite their patrons to come and hear them. Supplies of a tastefully designed program, together with striking window slips, etc., have been dispatched to agents, with a promise of liberal advertising in support. A very attractive full page advertisement appears on the front of the Daily Mail, inviting the public to this concert at any "H. M. V." dealers saloon. The company has spared neither time nor money to make the concert week idea a success. In addition to these special sales schemes, new supplementary records appear each month, and selected items from the popular Revues, of which the latest is "Joyland," and the new musical comedy "Tina."

The Latest Winner Record List.

The latest Winner record list may be described as making an appeal to all moods, to all hearts, and to all pockets, so varied is it in choice of titles—what you will at the humble price of ninepence each, i. e., two on one for eighteenpence. 'Twere perhaps invidious in the short space at my disposal to itemize any particular numbers, for much care has been expended upon their selection, and one may reasonably conclude that all have passed the severely critical test of the company's recording expert. It may be said without undue exaggeration that few, if any, poor records find their way to the light of publicity—hence in a measure the Winner reputation!

I cannot refrain however from drawing my readers' attention to the issue of records by Frederick Dawson, who is truly described as one of England's greatest pianists. He is an expert of rare accomplishment, and some of his best performances at the keyboard are happily now available on Winner records. Those who have heard these discs speak in terms of high praise, specially emphasizing the excellent and true piano fidelity of the recording thereof.

Associated Copyrights, Ltd.

This company was registered on February 9 with a capital of £6,000 in shares, objects to take over the businesses carried on by Copyrights, Ltd., and Universal Copyrights, Ltd., to carry on the business of agents for the production, publication and licensing of any literary, musical, dramatic, artistic or other work and for authors, composers, dramatists, artists and publishers, and to adopt agreements with the said old companies and the liquidators thereof. Signatories, E. P. Dennis, Cambridge Park, Wanstead, N. E.; Winifred O. Maddock, 16 Amphyll square, N. W. Private company. The number of directors is not to be more than five, the first are A. Clark, A. J. Mason, L. Sterling, J. E. Hough, and E. J. Marshall. Remuneration as fixed by the company. The Board of Trade authorizes the acquisition by this company of the undertakings of Copyrights, Ltd., and Universal Copyrights, Ltd., the books and documents of which are liable to inspection under Section 2 of the Trading with the Enemy Act, 1914.

TOWER 205 FEET HIGH WILL GRACE NEW VICTOR PLANT.

An Addition to the Present Cabinet Factory and a New Record Pressing Plant, Both Six Stories in Height, Are Being Planned—Novel Fire Escapes a Feature.

The Victor Talking Machine Co. has commissioned Ballinger & Perrot, architects and engineers, to prepare plans for a six-story and base-

ing which will make the tower stand out at night as a beacon light in the darkness. The plans also contemplate the finishing of the present cabinet factory, so that the facade on this street will harmonize with the architecture of the remainder of the building.

The construction of the building will be of reinforced concrete throughout with rolled steel sash frames and windows, glazed with wire glass, and heated and ventilated with blown air, similar to the wing which was completed last year, thus getting the maximum labor efficiency from the employees by providing working quarters which are conducive to these qualities.

The entire group of buildings for the cabinet factory is adequately provided with fireproof escapes in addition to the one main entrance, which will occur under the tower, and communicates with an incline, instead of stairways, which runs through the six stories of the building. This incline is designed to provide means of reaching the various floors and sections of the building and obviates the use of passenger elevators, and is found in practice to be eminently suited for the purpose.

The record-pressing building is to be a six-story, fireproof building, 91 by 283 feet, connected to the grinding building by bridges. This building is, as is usual with all the buildings of the Victor Talking Machine Co., of reinforced concrete construction throughout, of design to harmonize with the type of architecture of the remainder of the plant. On the top of the building will be arranged booths for the testing of records. When completed this building will be large enough to increase the Victor Talking Machine Co.'s output in records far beyond the present maximum production.

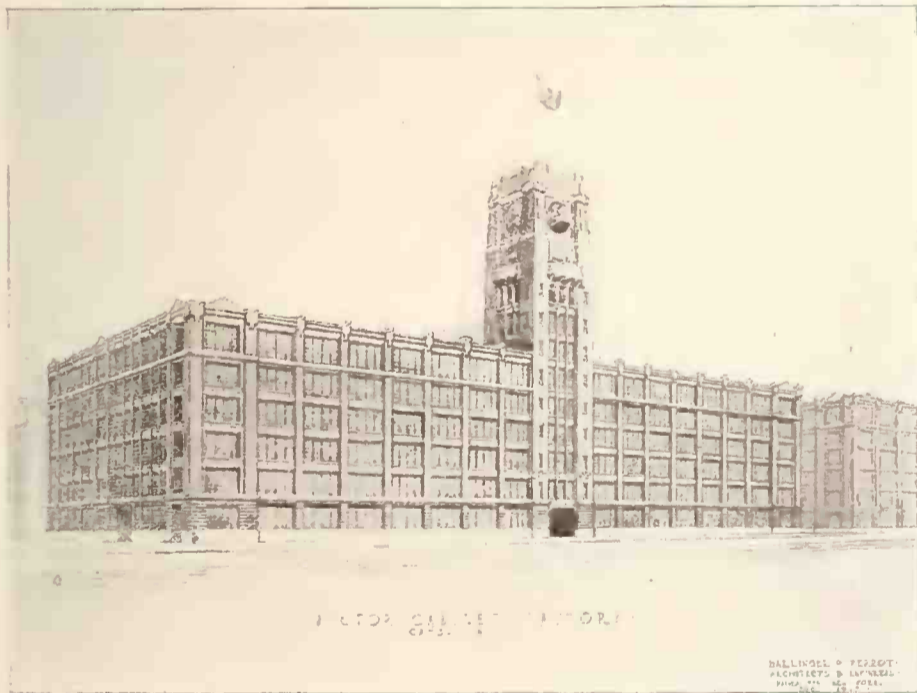

ment addition to its cabinet factory on Market street, Camden, N. J., from Delaware avenue eastward; also a six-story record-pressing building on Cooper street west of Delaware avenue.

The extension to the cabinet factory will completely build up the block from Delaware avenue to Front street, and add to the present cabinet factory 140,000 square feet of floor space. When completed this cabinet factory will be one of the largest and most up-to-date woodworking plants in the United States, the total amount of floor space in this group being twelve and eight-tenths acres.

A striking feature of the facade on Market street is a tower 205 feet high located in the middle of the building. This tower will supplant the existing sprinkler-tank tower and will be used for sprinkler and factory water supplies. The trademark of the Victor Talking Machine Co. will be located at the top of the tower on four sides, executed in glass. It is proposed to illuminate this tower at night with the flood system of light-

Reno
The Man of Many Parts



Accessories for any Machine Ever Made from the Year Dot to 1915

ROLLOPHONE
(Patent Applied For)



Closed.

The Latest and the Most Unique Hornless Machine on the Market

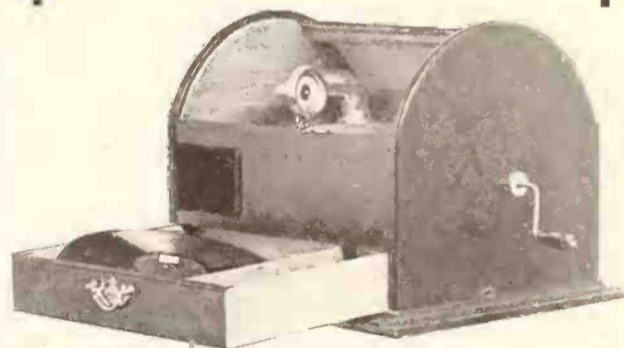

Opened.

Open or Shut, This Instrument Will Play Any Make of Needle-Disc Record

Order Sample Goods To-day
and

Write for New Illustrated Catalog

W. H. Reynolds (1915), Ltd.

Manufacturers of

Talking Machines, Records,
Accessories and Motors

45 City Road, London, E.C., ENGLAND

THE EDISON - BELL VELVET-FACE (VF) RECORD

DOUBLE-SIDED—NEEDLE-CUT—10 inch and 12 inch
IS THE SUPREME EFFORT OF GRAMOPHONIC ART

10 inch

2/6

12 inch

4/—

There are no faulty VFs as Every Record has to pass a crucial test before it is released for sale. The production is of the highest quality. The Titles and Subjects recorded are by the most prominent artistes in the Gramophone world.

If your jobber doesn't stock them try our Direct Service. It will pay you both for quality and price. Duty paid. For full particulars, Wholesale and Retail, apply to



E. HOUGH, Ltd., Edison Bell Works, Glengall Rd., Peckham, London, England

JAMES N. HAIRE DIES SUDDENLY.

Treasurer of Gately-Haire Co., Albany, N. Y.,
Passes Away on Tuesday.

(Special to The Talking Machine World.)

ALBANY, N. Y., March 14.—James N. Haire, treasurer of the Gately-Haire Co., Victor distributors of this city, passed away suddenly on March 14th, much to the regret of the entire industry.



J. N. Haire.

Mr. Haire has been associated with the Gately-Haire Co. since its formation when it took over the business interests of Finch & Hahn. As treasurer, many of the new plans of the concern were created and put into force by him, these helping tremendously in the rapid growth of this house. His associate, John L. Gately, and the members of the staff, are receiving the sympathy of the trade in their tremendous loss.

NEW VICTOR STORE IN BALTIMORE.

Cohen & Hughes, Victor Distributors, Arrange
to Open Third Retail Store in That City—
Plan Elaborate and Exclusive Quarters.

(Special to The Talking Machine World.)

BALTIMORE, MD., March 14.—Baltimore is going to have one of the most exclusive Victrola stores in this section of the country, according to the announcement of I. Son Cohen, of Cohen & Hughes, Inc., Victor distributors, who already have two stores in this city. This will make the third establishment, and, unlike the other two that handle the Victor line and pianos, the new place will be distinctly a talking machine house, handling exclusively the complete Victor line, and will be located at 14 North Charles street, the most prominent point in the downtown section. The new place will be ready for operation about the latter part of the month. Mr. Cohen stated that no expense would be spared in making the new establishment an institution that would commend itself to all lovers of music.

PENNSYLVANIA DEALERS MEET.

Association Holds Monthly Session in Pitts-
burgh on Monday—Discusses Trade Topics.

(Special to The Talking Machine World.)

PITTSBURGH, PA., March 14.—The Western Pennsylvania Talking Machine Dealers' Association held its regular monthly meeting last night

in the store of the W. F. Frederick Piano Co. There was a large attendance, including a good number of piano dealers who handle talking machines. President French Nestor presided. Trade topics were discussed informally, and the meeting proved a most enthusiastic one. Optimism in regard to the business outlook in the Pittsburgh district was the keynote of the evening.

TALKING MACHINE RECORDS BURN.

\$1,000 Worth of Records Destroyed In Fire
Which Endangers Fifty Families in Harlem.

An early morning fire recently destroyed \$1,000 worth of talking machine records and routed fifty families living at 324 West 125th street, New York, into the street in their nightclothes. The main floor of the building is occupied by the Meliphone Co., which operates a talking machine parlor where the latest records may be heard by dropping a coin into the slot. The records which were destroyed were stored in the basement, and made so much smoke that a second alarm was sent in. The cause of the fire is unknown. After an hour of hard work the fire was extinguished, but most of the records had been ruined.

GRAPHITE IN GREAT DEMAND.

Few people begin to realize the range of uses to which graphite is put, says the Scientific American, for it is an essential though minor ingredient in a great number of unsuspected connections as common as that of lead pencils. With many of these the graphite man is himself unfamiliar, beyond the simple fact that this or that manufacturer purchases from him; for in such uses it is apt to represent part of a secret process.

Lead pencils, lubricants for talking machines, electrical conductors, and black polishes and paints are prominent conventional uses, but it is liable to be present pretty much anywhere that anti-friction, unfading blackness, heat resistance, electrical conductivity or non-corrosiveness are desirable properties, and the fact that without graphite the derby hat as we know it could not be, is an example of its importance as an incidental ingredient.

RECIPROCITY.

Brown, who lived in the picturesque suburbs, returned home late one evening, with a package which he deposited on the dining room table. His wife, naturally curious, lost no time in starting to investigate. "What have you been buying, Jimmy?" she asked, taking up the package and untying the string. "A cornet," answered Jimmy; "I have been thinking for some time—" "A cornet?" was the wondering interjection of the wife. "I thought you knew better than to buy a cornet! You know very well that the man next door worries you almost to death with his." "Yes, I know," was the smiling response. "That is the one I bought."

The foolish man "darns" his luck—the wise man "inends" it.

Pick the Profitable Pathé

And repeat the big success its dealers are everywhere enjoying.

The Pathephone will sell easily where other talking machines fail even to create desire.

Persuasion is unnecessary when you demonstrate it—dealers seldom lose a listener, who eventually buys a phonograph.

Awake to the exceptional profit possibilities of the Pathé records—the demand everywhere is tremendous and consistently increasing—ALL owners of other disc machines will want a selection of these "real" records, truly.

Pathé Has Divorced "Perhaps" From Profits.

Write today before the "other fellow."

THE FISCHER CO.

Ohio Distributors

Euclid Ave. at Huron Road, - - - CLEVELAND, OHIO.



HIT APPROVAL PLAN IN BUFFALO.

W. D. Andrews & Co. Takes a Definite Stand in the Matter—Dealers' Association Delays Action—Expect Good Business During Lent—Victor & Co. Take Pathephone Agency—Talking Machine as Toastmaster.

(Special to The Talking Machine World.)

BUFFALO, N. Y., March 7.—Talking machine records on approval will likely be a thing of the past if the action of the local dealers is similar to that taken by the W. D. Andrews & Co., one of the largest jobbers and dealers in talking machines in the city. Agitation has been going the rounds for some time in this city to eliminate this abuse of the trade, and the dealers appeared to be unanimous that there was a distinct disadvantage in having their records out on approval, with the chances for sales being daily reduced.

Starting on Monday, March 6, the Andrews store shut off this line of activity by announcing that there would be no more records sent out on approval. This means that only outright purchases will get a record from the Andrews store. Mr. Andrews made the announcement on conspicuous cards throughout the store. The reason for the change in methods was that people taking the records on approval abuse the privilege that was accorded them by the store. Frequently they held the records too long and many times they were turned back in poor condition after the people had used them long enough, declaring that they were not satisfied with them. The fact that the records were held too long frequently blocked sales that might have been made in records that were out only on approval.

It is believed that the other dealers will follow in the wake of the Andrews store. There is a sentiment among them that the approval record method is a rap at the business and will be discontinued. It has been said by one of the dealers here that cases have been known where people with Victrolas have been having concerts in their homes on borrowed records which were procured with the understanding that they were to be purchased, only to have them turned back as not satisfactory after the day's use. Others have been kept at least two weeks.

The matter was considered at the meeting of the Talking Machine Dealers' Association and a referendum vote was decided upon. The vote was never completed, as there was so much discussion both ways on the proposition that the association kept its hands off.

It is expected that the talking machine business will be improved during the Lenten season. At least the dealers expect this, as there are so many people who taboo the public amusements that they will have their own entertainment in their own homes by means of talking machines.

A. Victor & Co. have taken the agency here for the Pathephone, and a fine demonstration room has been fitted up for the talking machines. The company is making a big effort to bring the Pathephone to great popularity in this city and hourly concerts have been arranged as an attraction to

A \$10 BILL FOR YOU

Clear profit in the sale of a single course in

The Herman Klein Phono-Vocal Method

Based upon the famous school of Manuel Garcia

The sale is made to the customer who is already on your books, from a demonstration outfit and practically without effort. No stock to carry, no capital tied up, for orders are filled directly by us.

Ten double-sided records, wonderfully made—twenty lessons—lead the student from the simple scale to the aria, and a comprehensive text book, compiled by Herman Klein, based on the method of Manuel Garcia, explains each step intelligently and interestingly. It is not a correspondence course but a complete method in itself.

This method increases appreciation of music and means more sales of high-class records and machines. Something more than a side line.

RETAIL PRICE \$25, FOR COMPLETE METHOD IN ANY VOICE

Ask about our demonstration outfit, sales aids for the dealer and other details—**you owe it to your business—Write TODAY!!!**

**THE MUSIC PHONE METHOD, 909 Putnam Bldg., 2 W. 45th St., New York**

draw the people to the store to see and hear the instrument. The advertisements of the company lay stress on the fact that it is not necessary to have the needles changed.

C. P. Chew, representing the Pathé Frères Phonograph Co., was at the Iroquois each day this week to meet the dealers of this city and western New York for the purpose of negotiating agencies for the Pathephone.

Victrola parties are quite popular at many of the clubs throughout the city. The latest to try the experiment for dancing was St. Patrick's Club on the East Side. The club used a Victrola for the dance that was held during the latter part of February, and it proved to be a great innovation: in fact so successful that the club will repeat with another series after the Lenten season.

The approach of the concerts by John McCormack and Mme. Schumann-Heink has given the Neal, Clark & Neal store the cue for advertising the records made by these artists.

Gould Brothers in Main street have reported a splendid business on Victrolas and records.

The Talking Machine Dealers' Association met last Wednesday at the Hotel Statler, the meeting developing into the annual banquet aftermath. Nothing weighty was discussed, but the good attendance in friendly groups talked over daily trade experiences. Secretary Bruehl stated that not one member but who was pleased with the present run of business.

Inability to obtain sufficient machines is the main

complaint of members, business being so good in both retail and wholesale ends that dealers are unable to keep up their stocks. In fact business is so good here in the record machine lines that it is injuring the piano trade to considerable extent.

The Buffalo Ad Club, one of the largest organizations of advertising experts in the country, on Saturday at a banquet utilized the phonograph to a unique degree. The ad men, in introducing John Barrett, former United States Minister to Siam, Panama, Argentina and Colombia, as a speaker, did not make him known through the ordinary agency of the toastmaster. Instead, a hidden phonograph in a corner of the room clearly enunciated that both Mr. Barrett and Thomas Thrift, of Cleveland, were scheduled as the speakers. It was a novel idea and was well received.

FIREPROOF RECORD RACKS.

C. J. Ianell, manager of the talking machine department at Bloomingdale Bros., Fifty-ninth street and Third avenue, which handles the Victor and Columbia lines, recently arranged to have installed a set of new record racks which are equipped with rolling doors and which are as fireproof as human ingenuity can make them. The doors lock at night, and the racks provide maximum efficiency and convenience for the members of the sales staff. Mr. Ianell reports the closing of a very satisfactory February, with a phenomenal increase in record business.

THE FEDERAL EQUIPMENT CO.

320-340 WEST STREET — CARLISLE, PA.

MANUFACTURERS OF

TALKING MACHINE AND RECORD CABINETS, PIANO, PLAYER AND TALKING MACHINE DEMONSTRATING ROOMS

WE HAVE THOROUGHLY MODERN AND WELL EQUIPPED

WOOD WORKING AND FINISHING PLANTS AND DRY KILNS

AND ARE PREPARED TO TAKE ON ADDITIONAL BUSINESS

WE MANUFACTURE TO ORDER SPECIAL DESIGNS OF TALKING MACHINE AND RECORD CABINETS

SEND US DRAWINGS AND SPECIFICATIONS OR SAMPLES ON WHICH TO QUOTE



**NO
NEEDLES
TO CHANGE**

1916 IS THE

Notice the picture above, showing the ordinary needle and the **PATHE SAPHIRE BALL** magnified. This is a striking illustration of one of the most important differences between the **PATHEPHONE** Method of Reproduction and that of other phonographs or talking machines. The needle is bound to dig into the record surface and wear it out. The **PATHE SAPHIRE**

travels over the down wave-like waves from forcing out the be

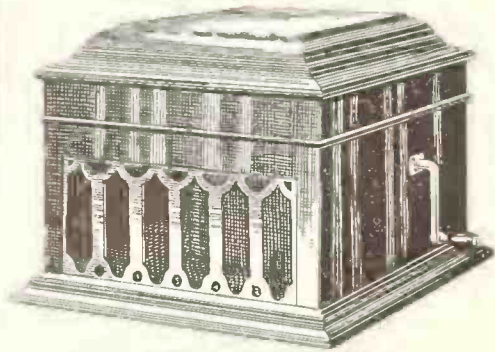

Model 50 Sells for \$50.

Ask the people to compare the **PATHEPHONE** with every other phonograph or talking machine. That's the line of least resistance for you. After they've heard the ordinary machines, they'll buy a **PATHEPHONE** just as surely as they prefer reality to imitation, art to crudeness, perfection to makeshift. **PATHEPHONES** stand comparison because they are above competition.

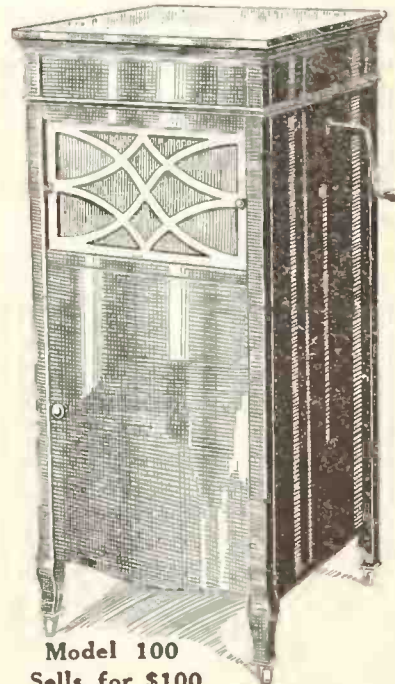

Model 100 Sells for \$100



So true, so vibrant, so performance of the **PA PHONE** that every real musical interpretation is satisfying manner never erred possible. This wo due to the **PATHE GE PHIRE REPRODUCE PATHÉ ALL-WOOD CHAMBER**, and the **FECT TONE-CONTR**



PATHE' FRÈRES

28 W. 38TH STREET

PLAYS
ALL DISC
RECORDS

Pathephone

R!

s in an up-and-
ning the music
tact and bring-
s. The PATHE

SAPPHIRE never wears out and never has to be changed.

The music lovers are buying PATHEPHONES all over the country! The PATHÉ Dealers in hundreds of localities are all reporting an enormous volume of business—they are having a phenomenal demand for PATHEPHONES for Christmas.



Model 200
Sells for \$200



A PATHÉ Agency is an exceedingly valuable franchise. How about your territory? Is it taken care of? Better get in touch with us to-day and reap the advantage of our National advertising campaign and the benefit to be derived by you through the use of the well-known name, "PATHÉ FRÈRES," familiar to millions of people every day who attend the moving-picture shows.

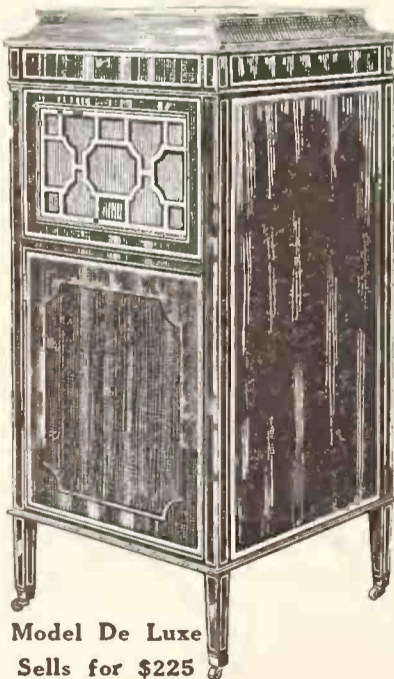

Model De Luxe
Sells for \$225

MONOGRAPH CO.
NEW YORK, U.S.A.





The Al Jolson records are among the fastest money-makers in the exclusive Columbia list—just as we predicted, only more so. Two new selections in the April list.



(Write for "Music Money," a book "full of meat" for those dealers interested in quick and frequent turnover of capital.)

Columbia Graphophone Company
Woolworth Building, New York

EDISON DIAMOND DISC JOBBERS' ASSOCIATION MEETS.

Much Important Business Transacted at Three-Day Session—Officers Elected for Present Year—Banquet Held at the Hotel Knickerbocker—Many Interesting Talks—Those Present.

The annual meetings of the Edison Diamond Disc Jobbers' Association were held at the Knickerbocker Hotel and at the Thimble Theatre, 10 Fifth avenue, New York, on Monday, Tuesday and Wednesday, February 14, 15 and 16. These were well attended by Edison jobbers from all parts of this country and Canada, and many business problems were taken up and discussed in an able manner. Little information was given out to the public, but chats with the various members indicate that these meetings were most important in every way, and that plans are under way to make 1916 an epoch in the distribution of Edison Diamond Disc machines and records.

Monday was devoted to the regular routine meeting, wherein the officers and advisory board were elected, as follows: W. O. Pardee, president; W. B. Smith, vice-president; H. G. Stanton, secretary, and Lawrence Lucker, treasurer. The advisory board consists of H. H. Blish, C. E. Goodwin and N. D. Griffith.

Tuesday was taken up with a conference with the officers from Thomas A. Edison, Inc., Orange, N. J., the officers of the corporation being tendered a luncheon by the association, this being held in the banquet room of the Knickerbocker. In the evening the jobbers were the guests of the factory, a banquet being held in their honor at Sherry's, followed by a theatre party which was given at the Hippodrome.

Wednesday, at the Thimble Theatre, an unusual program was carried out. William Maxwell, vice-president, started the ceremonies with a short chat on "Rough Stuff," and then the other speakers ably reinforced his efforts. John Constable, assistant chief engineer, spoke on "Cruelty to Motors"; W. H. Miller, manager of the recording department, on "Artists"; Delos Holden, general counsel, on "Infringements"; Mr. Boykin, on "Diamond Points"; J. R. Rogers, general traffic manager, on "Traffic"; L. C. McChesney, advertis-

ing manager, on "Advertising"; A. C. Ireton, general sales manager, on "Factory Fallacies"; T. J. Leonard, assistant general sales manager, on "Probationary Zones for Dealers," and also talks on "Record Returns," "Mechanical Service," "Applications," "Diamond Amberolas," "Tone Test" and other pertinent subjects, by Messrs. Baldwin, Brown, Davidson, Maxwell, Fuller and others. Mr. McChesney also talked on "Booking the Advertising Pictures."

An interesting sales dialogue, entitled "Bought and Partly Paid For" (billed as the first and last time on any stage), was given by Mark Mac Dermott and Miss Miriam Nesbitt, being produced by Frank Smithson, which was followed by motion pictures, "The Voice of the Violin."

On Thursday, February 17, the jobbers took a trip to the Edison factory, where they spent an all-around enjoyable and instructive day.

Among those present were: E. Bowman, C. B. Haynes & Co., Richmond, Va.; H. G. Stanton, R. S. Williams & Son Co., Toronto, Ont., Canada; Walter Kipp, Kipp-Link Phonograph Co., Indianapolis, Ind.; W. B. Smith, L. N. Bloom and A. O. Peterson, of the Phonograph Co., Cleveland, O.; D. W. Schultz, Schultz Bros., Omaha, Neb.; W. A. Meyers, Williamsport, Pa.; H. H. Blish, Harger & Blish, Des Moines, Ia.; Laurence H. Lucker, Minneapolis, Minn.; A. Buehn, Buehn Phonograph Co., Pittsburgh, Pa.; W. O. Pardee, H. L. Ellenberger, of the Pardee-Ellenberger Co., New Haven, Conn.; F. H. Silliman, Pardee-Ellenberger Co., Boston, Mass.; George L. Babson, Phonograph Corp. of Manhattan, New York; F. E. Bolway, Syracuse, N. Y.; Fred Babson and C. E. Goodwin, the Phonograph Co., Chicago, Ill.; N. D. Griffith and P. R. Hanley, American Phonograph Co., Albany, N. Y.; James Chandler and T. E. Dean, Chandler & Co., Bangor, Me.; J. G. Harrison, St. John, N. B.; William A. Schmidt, the Phonograph Co., Milwaukee, Wis.; M. N. Blackman, the Pho-

nograph Co., Kansas City, Mo.; O. A. Lovejoy, Southern California Music Co., Los Angeles, Cal.; Robert L. Proudfit, Proudfit Sporting Goods Co., Ogden, Utah; R. B. Allen, F. S. Heminway and H. H. Curry.

LARGE BUYERS OF SUPPLIES.

The Unit Construction Co. Recently Purchased \$30,000 Worth of Glass in One Month—Other Big Purchases for Construction of Unico Booths Being Made at All Times.

Thirty thousand dollars' worth of window glass was recently purchased during one month by the Unit Construction Co., Thirty-first and Chestnut streets, Philadelphia. This house also buys thousands of dollars' worth of felts, woods, varnish, paints, etc., all of which enter into the construction of Unico booths for talking machine and player-piano rooms.

These figures are given to show the magnitude of the operations of this company, and to show that in the field of booth building it has involved thousands of dollars in merchandise of all kinds, to say nothing of the cost of its factory and maintenance.

A feature of the Unico booths is the fast service rendered to the dealer. For example, if a dealer orders a Unico booth, 9 by 9 feet, for his store, all he has to do is to write to the company and the booth will be shipped to him by return express. Through this service it is possible to fit up a store in a few days.

Rayburn Clark Smith, president of the Unit Construction Co., reports that business is excellent and states that the number of big installations have greatly increased during the past few months. Mr. Smith also states that the number of dealers who realize that properly equipped warerooms are necessary for efficient exploitation of talking machines and player-pianos is increasing numerically every week.

NEW COLUMBIA ARTISTS.

Thomas Quinlan, who was recently appointed manager of the Columbia Graphophone Co.'s operatic and concert department, stated this week that several contracts had been closed the past fortnight whereby artists prominent in musical circles both here and abroad will record exclusively for the Columbia Co. in the future. Among these artists is a prominent tenor who has achieved remarkable success at all his appearances. The names of these new artists and their records will be announced in due course. The Columbia Co. is steadily increasing its already large roster of notable artists.

ADD SEVERAL NEW MODELS TO LINE.

The Nanes Art Furniture Co., New York, manufacturer of the Savoy gramophones, has recently added to its line several new models which have been well received by the company's dealers. These new models include a large cabinet machine which will retail at \$65 and a complete line of smaller machines.

"Standard" Record Cleaner

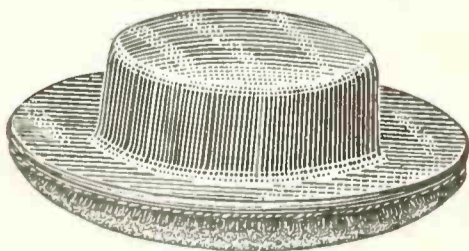

Price, 50 Cents, List
Patented June 2, 1914.

Send 10 cents in stamps for a sample cleaner. Write on your business letter head only. Place regular orders through your jobber.

STANDARD GRAMAPHONE APPLIANCE CO.

237 LAFAYETTE STREET

NEW YORK

We also manufacture the Simplex Record Cleaner, Price 15 cents, list.

ARTISTIC AND ATTRACTIVE

Grips the record surface and clings as if on rails.

Extended brush area cleans record with one sweeping circuit.

FOSTER & WALDO HAVE FINE VICTROLA DEPARTMENT.

Quarters in Minneapolis Ideally Arranged for Display and Demonstration of Machines and Records—Various Wholesale and Retail Houses Report Excellent Business.

(Special to The Talking Machine World.)

ST. PAUL AND MINNEAPOLIS, MINN., March 6.—Foster & Waldo's new Victrola department is an ideal arrangement. It may not occupy the greatest amount of floor space and there may be some more ornate, but one will travel far to find a more harmonious and effective disposition of space. Nearly a score of demonstration rooms, all with outside lighting and placed around a central court for reception and display purposes, provide an excellent retail plant. The firm has converted one entire floor of its building into the Victrola department, and is going after the business with the energy characteristic of the house.

Exceptionally fine business is reported by Manager Robert Souders, of the Columbia Co. "The February and March sales have held up to the volume of trade we enjoyed preceding the holidays," said Mr. Souders, "and we see no signs of

a let-down. We have two men on the road in this territory and will send out more as soon as we can get desirable men. Sales of Columbia instruments in the stores in Minneapolis and St. Paul are most satisfactory to all."

The Minnesota Phonograph Co., specializing in the Edison line, can't find anything but joy in the business.

"Our February sales were nearly double those of the corresponding month of 1915," declared President Laurence H. Lucker. "C. A. Briggs, a well-known salesman, has been added to our staff. Mr. Zellner, of New York, from the Edison head office, will represent the company in this territory and will make his headquarters with the Minnesota Phonograph Co. We are preparing a series of 'tone tests' similar to those of last season and expect to open with Alice Verlet, who made a striking success here before. The tone tests are

of great value in stimulating the sale of phonographs."

The Beckwith-O'Neill Co. reports one great drawback in its business, that being the old one—inability to obtain goods. "The shortage is more acute than it was before the holidays," complained Mr. O'Neill. "We can't assemble a full line for show purposes and we are compelled to devise all kinds of schemes to fill orders. But even so this condition probably is better than being overstocked."

St. Paul's big department store, The Emporium, which went into the talking machine business some two months ago on a big scale, is reported as wholly satisfied with its venture.

"We can't get Victrolas fast enough, but otherwise we are quite satisfied with the trade outlook," remarked Manager Shaw, of the Cable Piano Co.'s St. Paul store.

The agency for the Victor Victrola has been secured by the Cable-Shelby-Burton Piano Co., of Birmingham, Ala.

DESCRIBES SHELTON MOTOR.

Interesting Description in the Scientific American of This Electric Motor for Talking Machines Invented by W. G. Shelton.

Under date of February 12 the Scientific American carried the following interesting article, headed "Electric Motor for Phonographs," relative to the Shelton electric motor:

"No longer is it necessary for owners of the conventional phonographs to crank the mechanism in order to play the records, for there has recently been introduced a small electric motor that can be instantly applied to any disc type of phonograph. The motor weighs about three pounds and is made

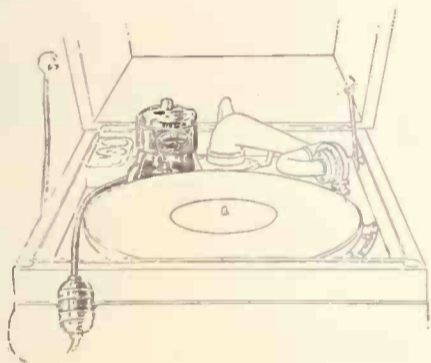

Shelton Motor on Machine.

to operate on either direct or alternating current. It is provided with a rubber disc which makes a friction contact with the periphery of the phonograph turntable. With the exception of removing the crank handle, no other change is necessary in converting a phonograph into an electric one, using the small motor." The accompanying diagram shows the Shelton electric motor in use on a machine.

W. Gentry Shelton, president of the Shelton Electric Co., New York, and inventor of the Shelton electric motor, is widely known in technical and electrical fields through his numerous inventions, all of which have achieved wide success. Among Mr. Shelton's most popular inventions, all of which bear his name, are a dental engine, high frequency generator, portable vibrator, portable hair dryer, high speed centrifuge, portable hand massage vibrator, electric drink mixer and pedestal machines, vibrators, etc. Mr. Shelton is thoroughly familiar with all phases of electrical construction, and experimented with the Shelton electric phonograph motor for more than a year before placing it on the market. Its remarkable success has well justified his efforts.

OPEN COLUMBIA DEPARTMENT.

Spear & Co., the well-known furniture house, who will open their new home on West Thirty-fourth street next week, will maintain a very attractive talking machine department, handling Columbia products exclusively. J. A. Friedman, a talking machine man of extensive experience, will be in charge of the Columbia division.

"Music for Everybody"

OPERAPHONE RECORDS

Retail at 35 cents.

Are equal to any.

Are 8 inches in diameter.

Are double sided.

Play as long as the average 12 inch records of other makes.

Are vertical cut.

Play with an ordinary steel needle.

Play on any lateral cut record machine with a small attachment which is simple to use and inexpensive.

Our catalog is up-to-date and there are no duplicate titles; the songs are by the popular artists.

The records are the product of our own laboratory and factory.

Send for catalog and latest list.

Operaphone Manufacturing Corporation

Office: Fifth Avenue Building, Madison Square, New York

SUCCESSFUL COLUMBIA CAMPAIGN.

Advertising of High Human Interest Being Used to Help Dealers—Electric Grafonolas Featured with Excellent Results—Exceptional Sales Being Reported.

The Columbia Graphophone Co., New York, is conducting an advertising campaign in the newspapers at the present time that is indicative of the broad policies of co-operation which characterize the service the company is extending its dealers.



The Band!

JUST as stirring on Columbia Records as it ever was on the street or stage—and you hear it at home in all its vigor, in all its force and dramatic strength!

Band music on Columbia Records is vivid, rich reality—thrilling in marches that quicken the blood—noble and stately in the overtures of the world's master-composers.

Only an actual band performance can equal the power, the martial fire, the surging strength and sparkling brilliance of these Columbia Records:

A1802	10-inch	UNDER A PEACEFUL SKY. (Van Eton.) Prince's Band.
		NEW COLONIAL MARCH. (Hall.) Prince's Band.
		75c.
A5688	12-inch	UP THE STREET, March. (Baby O. Morse.) Prince's Band.
		BAY STATE COMMANDERY, March. (Barrett.) Prince's Band.
		\$1.00
A1798	10-inch	BRIDE ELECT MARCH. Columbia Band.
		YOUNG GUARD MARCH. Prince's Band.
		65c.

After you hear these band records, you'll always ask for COLUMBIA RECORDS! There's a Columbia dealer near you who'll gladly play them over to you.

Columbia Records in all Foreign Languages

New Records go on sale the 20th of every month.

COLUMBIA GRAFONOLAS and DOUBLE-DISC RECORDS

FOR SALE BY

Two of the advertisements in this campaign are reproduced herewith, and the human interest appeal in this copy has been a very important factor in the results it is achieving for Columbia dealers. Up to date the Columbia Co. has used this advertising in a number of the leading trade centers,

TIFFANY MOTOR CO.

MANUFACTURERS OF ELECTRIC MOTORS FOR TALKING MACHINES

75 FULTON ST. NEW YORK CITY

and, as will be noticed on the proofs of the advertisements, there is room at the bottom of each piece of copy for a list of the city's dealers handling the Columbia product. There is absolutely no cost

garding the character and scope of the advertising. The advertisement featuring the Columbia Grafonolas electric has been particularly effective, Columbia representatives closing numerous sales as a direct result of the advertising.

TALKING MACHINE MEN TO DINE.
Local Association to Hold Annual Banquet at Hotel McAlpin on April 12.

At a meeting of the executive committee of the Talking Machine Men, Inc., held on March 8 at Keene's Chop House, New York, and attended by President John E. Hunt, Secretary Sol Lazarus, J. Y. Young, H. Jaffee, A. Galuchie, Henry Mielke, J. B. Coughlin, Meyer Goransky and R. B. Foster, it was voted to hold the annual banquet of the association at the Hotel McAlpin on April 12 at 7.30 p. m. The members of the talking machine trade in general are invited to attend and the tickets will be \$3 each.

At the meeting it was reported that the association was showing a pleasing growth in membership and that the prospects for its future activities were very bright.

TO MAKE THE VICSONIA.
Walter M. Seymour Takes Over Manufacture of New Reproducer.

Walter M. Seymour, who for some time past has been sole sales agent in the United States and Canada for the Vicsonia, a reproducer for playing vertical cut records on various talking machines of leading makes, has taken over the actual manufacture of that reproducer and will, in future, handle it direct from the factory office, 311 East 134th street, New York.

NO OUTSIDE REPRESENTATIVES.
Only Myron J. Schloss and Edwin G. Schloss Authorized to Represent Schloss Bros.

In order to prevent the possibility of a misunderstanding in the trade due to the reported activities of some unnamed person, Schloss Bros., the successful manufacturers of talking machine cabinets at 637-645 West Fifty-fifth street, New York, announce emphatically that the only trade representatives of their house are Myron J. Schloss, president of the corporation, and Edwin G. Schloss, general manager, both of whom are well known locally. No one else has the authority to represent the corporation of Schloss Bros., either in the taking or placing of orders.

REVIEWING VICTOR-MACY CASE.
(Special to The Talking Machine World.)
WASHINGTON, D. C., March 8.—The United States Supreme Court decided to-day to review the case of the Victor Talking Machine Co. vs. R. H. Macy & Co., New York, in connection with the right of the store to sell Victor products at cut prices. The Victor Co. won its case before the United States Circuit Court of Appeals on an appeal from a decision in favor of the defendant in the lower court.

VICTOR RECORDS FOR EASTER.
With the opening of the Lenten season the Victor Talking Machine Co. has sent to its dealers elaborate Easter record hangers, bearing substantial lists of records particularly suitable at that season. There was also sent to the trade at the same time special supplements of Victor Easter records for distribution among the retail customers.

The Wall Damm Music Co., of Brazil, Ind., is doing an excellent business in the Edison Diamond Disc line.



ELECTRIC GRAFONOLAS
—always ready for instant use.
—moving the tone arm starts the record

Electric!

The Columbia Graphophone Company presents the last word in sound-reproducing instruments—

The New Electric Columbia Grafonola \$200

No need of any attention from you, once the electric current is on, aside from changing records. To start the instrument you simply bring the tone-arm over to playing position.

It operates perfectly on any current, whether direct or alternating; is adaptable to any voltage; may be attached to any socket; and can be depended upon to give continuous, silent, effective service under any and all conditions.

Dealers are ready to supply the Electric Columbia Grafonola in four models at the prices of \$150, \$160, \$200 and \$250.

New Columbia Records on sale the 20th of every month.

COLUMBIA DOUBLE-DISC RECORDS and the COLUMBIA GRAFONOLA

FOR SALE BY

to the dealers for this advertising, the Columbia Co. including it as a part of its efforts to insure the prosperity of its dealers. The success of this campaign has been instantaneous, and many Columbia dealers have written the Columbia Co. enthusiastic letters of praise re-



WHY DON'T YOU SELL DAYTON BICYCLES, TOO?

Manufacturers, jobbers and dealers are co-operating in a big popularizing movement for "A Million Bicycles in 1916." Why don't you sell your share? There is a nice profit in Dayton Bicycles, as many dealers in musical instruments and supplies have found out to their advantage.

Write for 1916 catalog of Dayton Bicycles—for 23 years America's finest wheel. Be sure to address Bicycle Advertising and Sales Division—

THE DAVIS SEWING MACHINE COMPANY
Manufacturers of Dayton Motorcycles—Bicycles—Motor Bicycles
DAYTON, OHIO



THORPE ELECTRIC MOTORS

FOR TALKING MACHINES (Operate on all currents)

29 West 34th Street

New York City

TO VISIT VOCALION DEALERS.

W. H. Alfring to Make Extended Trip Through the West and South—Will Arrange for a Number of New Agencies for That Line—Exclusive Territory Policy Works Out Well.

W. H. Alfring, wholesale manager of the Aeolian-Vocalion division of the Aeolian Co., New York, left Thursday for an extended Western and Southern trip. Mr. Alfring will visit the Aeolian-Vocalion dealers in this territory, and will also consummate a number of deals with prominent concerns which have applied for the Aeolian-Vo-



W. H. Alfring.

calion representation since the first of the year. Before leaving for the West Mr. Alfring briefly discussed the fundamental principles of the Aeolian-Vocalion wholesale campaign and commented upon the policies which dominate this very successful department of the Aeolian Co.'s business. Mr. Alfring said:

"One of the very first things which the Aeolian Co. decided upon when its wholesale division was organized was the policy of placing the Aeolian-Vocalion line as an exclusive proposition with the leading dealer of a city. We felt that dealers of the high class and standing which is characteristic of all Aeolian representatives would require definite assurance as to the quality of competition. By giving a dealer an exclusive agency we were certain that the quality and prestige of our products would be best maintained at all times.

"The value to the dealer of this exclusive territorial arrangement is naturally very great. He can feature his line with the full assurance that his expenditures and efforts will produce tangible and direct results, and he need never be concerned with the possibility of a competitive music house opening an establishment around the corner; pro-

vided, of course, that he exploits and handles the Aeolian-Vocalion as the leading instrument of the phonograph type and gives it a representation commensurate with its quality and musical merit.

"It is not the policy of this company to make frequent changes in the personnel of its dealer organization. We have, therefore, moved with comparative deliberation in the selection of our Aeolian-Vocalion representatives, and every dealer who has arranged to handle the Aeolian-Vocalion has done so with the definite understanding that his appointment will be a permanent one so long as he fulfils his part of the arrangements, and that he will receive the co-operation of the Aeolian Co.'s organization in every single department.

"It is hardly necessary to point out that the Aeolian-Vocalion has been and is being featured in a national advertising campaign of vast magnitude. An impressive list of the leading magazines contains one and two page advertisements devoted to the Aeolian-Vocalion, and this publicity is being turned into profitable sales by our dealers, who, with their exclusive arrangements, are in a position to handle each and every inquiry in their city.

"Since the first of the year we have received numerous applications from successful houses for the Aeolian-Vocalion representation, and on my present trip I expect to close several of these deals. We have been well pleased with the success of our wholesale business to date, and from present indications our 1916 business will be a forerunner for an active wholesale trade with the Aeolian-Vocalion in all parts of the country."

RECORDS POPULARIZE SYMPHONIES.

Talking Machine Has Proven a Great Factor in Arousing and Increasing Public Interest in the Work of Symphony Orchestras Throughout the Country, Declares Prof. Carl Busch.

(Special to The Talking Machine World.)

KANSAS CITY, Mo., March 8.—Any words coming from Prof. Carl Busch, of this city, in regard to any musical features are always listened to with respect, for Prof. Busch is recognized as the leader of Kansas City music. As a composer he has attained national fame and his name is well known to music lovers throughout the world. He is at present leader of the Kansas City Symphony Orchestra, and it is largely through his efforts that this organization has reached its present efficiency.

In a recent interview he spoke as follows concerning phonographic records:

"There is one influence which is quite unexpectedly helping symphony orchestras to gain popularity. I refer to the records of overtures and symphonies now made by the phonograph companies. In looking over the various catalogs I find that such overtures as Weber's Der Freischutz, Beethoven's Leonore No. 3, the Prelude to Lohengrin, Nicola's Merry Wives of Windsor, Wagner's Tannhauser and Schubert's Rosamond and many others are already made. The recording of symphonies has just begun, but already I find the

Andante of Beethoven's Fifth Symphony, the Schubert and Unfinished Symphony complete, one movement of Beethoven's Pastoral Symphony, Schubert's B Minor complete, two movements of Mendelssohn's Italian Symphony, the Jupiter and G Minor Symphonies of Mozart besides movements of Wagner's operas and of the Symphonies of Dvorak, Tschaikowsky and Haydin.

"Nothing could be devised to better prepare the concert-goer for the full enjoyment of symphony performances than the repeated hearings of these records. The prejudice of many against symphony performances is caused by lack of familiarity with the themes which after a few hearings the ear learns to separate from the mass of orchestral harmony. Just as soon as that familiarity is attained just so soon the listener enjoys symphonies in preference to all other forms of music.

"I cannot too highly recommend the repeated hearing of these records as a proper preparation for the full enjoyment of orchestral performances, and it is to be hoped that the record makers will reproduce all the great symphonies, which will be of great advantage to auditors and orchestras."



702—Mahogany, Golden Oak, Fumed Oak, Weathered Oak. Nickel-plated trimmings. Lock and key. Rubber-tired wheels. Height, 30 ins. Top, 17 x 20 1/2 ins.

NOW IS THE TIME

to prepare for your Summer business.

Do not wait, but be sure to have the right kind of merchandise in stock.

Above is shown one of our cabinets that will help boost your Spring and Summer trade.

"THE VERY BEST"
Get Our Catalog Today
DO NOT WAIT!
It may be the means of making many sales for you.

SCHLOSS BROTHERS

637-645 West 55th St., New York

Telephone: Columbus 7947

Do You Sell Your Customers Improved Half Tone Needles?

If not, why not? A trial will convince. Fits all talking machines. Smooth, Clear, Sweet Tone. Saves Records, Eliminates Harshness.

Sample and Prices on Request

BURLEY & BIESINGER

278 West Ferry St.

Talking Machine Specialists

Buffalo, N. Y.

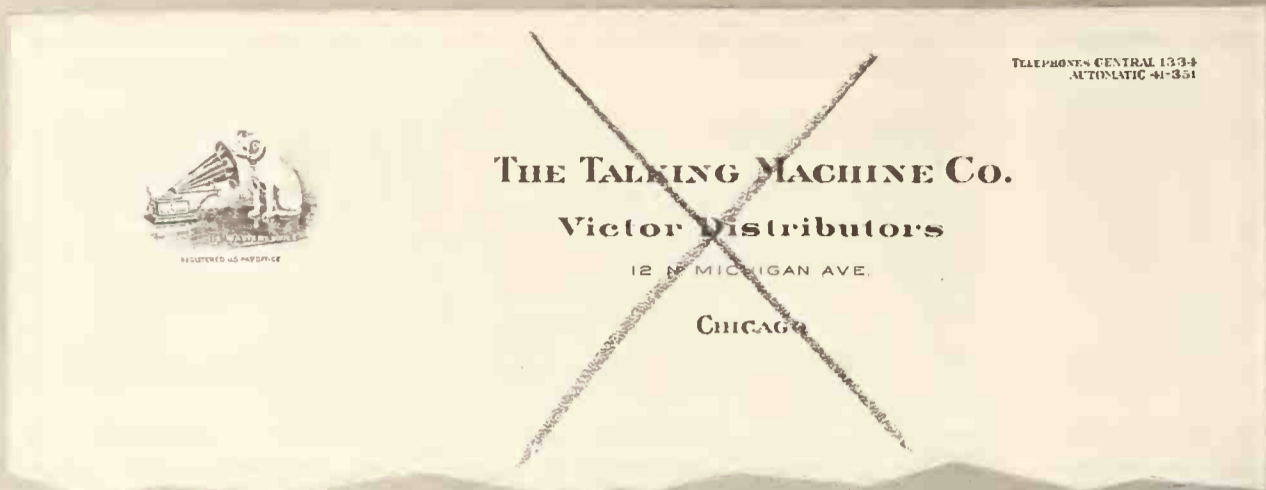

Announcement

Our change of name is an Accomplished Fact -- Although it is a Small Simple Change, We feel that it serves to Indentify us more strongly with the Great city in which we have had our operations and had the privelege of serving the enormous following of Victor Dealers that we can rightfully call our own ~ ~ ~ ~



FROM OUR CHICAGO HEADQUARTERS

E. P. VAN HARLINGEN, Manager
HENRY S. KINGWILL, Associate

World Office
Consumers' Bldg. 220 South State St., Chicago
Telephone: Wabash 5774

(Special to The Talking Machine World.)

CHICAGO, ILL., March 10.—The month of February has gone into history and part of March is past, with no special development of note unless it be the remarkable increase which has been shown over the same period of last year. Both the retail and wholesale divisions have enjoyed a really prosperous month, wholesalers uniting in saying there is an increase of about one-third over last year.

One thing that has been noticeable has been the long-encouraged step upon the part of dealers to lay in a large stock far in advance, and more than one dealer who was disappointed in his shipment last fall is already making preparations for Christmas of 1916.

There have been no particular preferences upon the part of the buying public, and dealers report that all sizes of machines have enjoyed their proportionate share of the demand. The same thing holds true in records, and popular numbers, old standard numbers, operatic and dance selections seem to receive about an equal call. A number of dealers have spoken with some surprise of the continued call for those records of the dance variety, and those who predicted that the fad would die ere this have been genuinely surprised.

The call for accessories has also been good, which is said to be due in great part to the large number of new machines which have been placed on the market recently.

Fuhri's New Post.

W. C. Fuhri, who, as elsewhere reported in this issue, has been appointed United States manager of the Columbia Graphophone Co., leaves a host of friends here who will regret his absence from Chicago while rejoicing in his promotion. Mr. Fuhri came to Chicago from St. Louis, where he had been manager of the local branch, ten years ago on his appointment as district manager, and had made his headquarters here ever since. He is now taking a brief rest in Michigan, but will be in New York to assume his new and improved position about the 15th of the month.

Mr. Fuhri's successor as manager of the Central West district has not yet been appointed, but this will probably be done by April 1.

Good February for Columbia.

C. F. Baer, manager of the Chicago office of the Columbia Graphophone Co., stated that the February business made a remarkable showing in that it was only slightly behind December, while it secured a moderate increase over January. The increase over February, 1915, amounted to 170 per cent. "A notable feature of our local business," said Mr. Baer, "is the results obtained from the very liberal advertising campaign that the company has been pursuing in the Chicago dailies. The effect of this publicity is being felt in an increasing degree each month. The idea of printing the names of all Columbia dealers in Chicago and suburbs has proved very effective, and a number of our dealers tell us that they trace a large number of direct sales to people that come into the store bringing copies of the advertisements with them. A generally satisfactory condition of trade in Chicago is shown by the fact that Edward Blimke, who has for years visited the dealers outside the loop, showed an increase in his sales of over 200 per cent. in January and February.

"The record situation is now in better condition than it has been for months, and we are now able to fill orders from our dealers from 95 to 98 per cent. complete. While there is still a shortage on machines, the situation here, too, is improving. On the higher priced machines we are able to care for our trade fairly well. We have been almost out of the market on the lower priced machines, but the big increase in the capacity of the factory is now beginning to tell and they will soon be able to supply motors for the cheaper machines, and this condition will then be rectified."

New Advertising Manager.

G. I. Stanton is now in charge of the advertising department of the local branch of the Columbia Graphophone Co. He is specializing on the well-organized system of the house in co-operation with the dealers in this territory in advertising and selling matters. He succeeds Mr. Kennedy, who is now traveling for the Chicago office in western Illinois and eastern Iowa.

The Orotund Soundbox.

The Combination Attachment Co., of 624 South Michigan avenue, has increased its manufacturing

facilities so that it is able to make prompt shipments of the Orotund sound boxes either separately or in combination with attachments equipping them to play any disc record on any machine. The company is receiving many tributes regarding the excellent tonal qualities of this sound box, and manufacturers entering the market and wishing to work along quality lines would do well to familiarize themselves with the company's product.

Furnish Electric Signs.

The Chicago Talking Machine Co. is mailing to its trade a circular concerning the "Radium Flash" electric sign, which is especially adapted for window use for talking machine dealers. It is a very effective sign, beautifully framed in Circassian walnut, and the legend can be changed daily, or as often as one wishes, by means of the font of "type" which is a part of the outfit. It is 51 inches long, 8 3/4 inches in height and 6 inches deep and flashes the message to the passer-by. The circular gives a large number of legends calling attention to Victor machines and records, for the benefit of purchasers of these signs.

The Chicago Talking Machine Co., in its monthly budget to dealers, furnishes a copy of a very effective form letter which can be used in diplomatically "punching up" machine owners who have not visited the store to purchase records for several months.

Lyon & Healy Affairs.

The annual dinner and theatre party of the young women employed in the talking machine department at Lyon & Healy's was held on the evening of Tuesday, February 29. An excellent dinner was served at 6 o'clock at the Auditorium Hotel, and after that the party moved on to the Illinois Theatre to enjoy "Chin-Chin." There were forty-eight young women in the party and they were chaperoned by Mr. and Mrs. Marquette A. Healy, Mr. and Mrs. L. C. Wiswell and Mr. and Mrs. J. B. Ryde.

A notable improvement in the service which Lyon & Healy are affording to their dealers was inaugurated this month, and arrangements were completed whereby in the future the handling of all wholesale shipments of machines will be carried on from the principal stockroom at the Lake street warehouse. In this way a great deal of time is saved, as the congestion of Chicago's loop district is avoided, as well as the time required to handle twice. The force at the extra warehouse will also have the opportunity of specializing on machines. The assembling of record orders will continue to be done at the main store, and this force will do nothing else, thus effecting a saving of time in this direction also. Record orders are then combined with machine orders, and the shipment is made at one time.

The month of February with Lyon & Healy showed a 40 per cent. increase over February of last year and, according to Manager L. C. Wiswell, was the best February in the history of the house.

Harry J. Fitzpatrick, formerly of the Victor Talking Machine Co., is now connected with Lyon & Healy as the successor of E. P. Bliss, who resigned recently to go to the East. Mr. Fitzpatrick is now on his first trip through Indiana and Michigan, which territory he will cover.

A new addition to the retail talking machine department is H. G. Bartruff.

R. T. Schenck, who is to open the new talking machine department of W. H. Wheelock & Co. at Peoria, Ill., in a few weeks, is temporarily with Lyon & Healy for the purpose of getting a few pointers on store management.

Sonora Man in Chicago.

Frank J. Coupe, who has charge of the publicity for the Sonora Phonograph Corp., has been in Chicago for the past two weeks working upon the rearrangement of Sonora interests here. The Sonora Phonograph Co. of Illinois will become a branch of the parent organization, and as such

(Continued on page 63.)

Prepare For Moving Season!



Order A Talking Machine Moving Cover

The Modern Method
Insures Safe Handling

Khaki, heavily padded with **substantial felt**, quilted, fleece-lined and strongly sewed.

This cover makes it almost impossible to mar or damage the Victrola.

We make them up promptly in our shop to fit any make of Talking Machine.

Price \$5.00

When ordering covers, be sure to mention make and style of machine to insure a perfect fit.

Talking Machine Jobbers, write for our special inducements

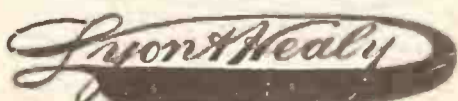

Chicago

*Be Determined
to obtain
Good Service*



Victrola Service

Our Service to Victrola Dealers is extraordinary because we have every up-to-the-minute equipment for prompt and accurate order-filling. Every new labor-saving device that is successful becomes part of our system.

To our untiring efforts to improve our Service we trace our large and growing business.

You will be benefited by our Service

Convince yourself by sending us your orders.

Lyon & Healy

Victor Distributors
Chicago

FROM OUR CHICAGO HEADQUARTERS—(Continued from page 61).

will benefit from the closer relationship which such a move will bring. Mr. Coupe says that all details in this connection have been arranged and enough shipments will be received within the next ten days to fill the \$100,000 worth of Western orders that are on file in Chicago and leave a nice surplus stock besides.

William F. Martin, who is in charge of the Sonora destinies in the four States surrounding Chicago, has been kept very busy with the demands which dealers who have been anxious to take on the Sonora line have made upon him. During the past six months the Sonora has made very rapid progress with the general public in the Middle West, and dealers have not been slow to realize it.

Takes Responsible Position.

C. B. Mason has been appointed floor salesman of the Chicago Talking Machine Co., succeeding H. J. Flentye, Jr., resigned. Mr. Mason was formerly assistant credit man in the large department store of M. S. Donaldson, of Minneapolis, and was also associated with Don Preston, manager of the talking machine department of that house.

Three New Firms in the Republic Building.

The American Cyrophone Works, manufacturers of the Cyrophone talking machine, have opened offices on the tenth floor of the Republic Building. Two models are shown, one of the smaller cabinet variety, which is made in part of metal, and the other in a library table form.

In room 1727 G. Weigand & Co. are showing the "Ariel" line. Five models are shown, which include a number of interesting features. The machines are nicely finished and these find a ready market.

The Playerphone Talking Machine Co. has just opened offices on the sixteenth floor, having moved from the Hartford Building. The company manufactures the Playerphone line of machines, which have been preciously described in *The World*.

Good Record Window.

A. T. Boland, manager of the Grafonola Shop, 14 North Michigan avenue, has had a display in

the north window for the past two weeks which has been productive of excellent results in the sales of popular records. As will be seen by the accompanying illustration, photographs of entertainers making Columbia records are connected by streamers with the records themselves in the front of the window.

There are photographs of Irene Franklin, Frank Tinney, Bert Williams, Ray Atwell, Al Jolson,



Attractive Columbia Window.

Chauncey Olcott, Raymond Hitchcock, Weber and Field and Margaret Farrell. In the center of the group is a picture of "Cohen" cut from a theatrical poster, and this is connected with a Cohen record by Joe Heiman & Co. The beauty of the trim is that, while it is exceedingly effective, it is very inexpensive. In fact, Mr. Boland himself constructed most of the properties, including the lattice work and the pedestals supporting the electric globes. It simply shows what a little ingenuity and

a little interest in the window display proposition can accomplish, and Mr. Boland's trim is especially worthy of attention because it can be reproduced by dealers in small towns with the facilities they have at hand. Outside of the lattice, the lumber for the posts and the cheese cloth used in covering them, the only outlay was for the service of a sign painter in producing the legend above the display.

Installs Columbia Department.

The Humboldt Furniture Co., of 2412 North avenue, one of the largest concerns outside of the loop, has just added a Columbia department and has fitted up handsome quarters on the first floor of the building, with three demonstration booths. The size of its contract indicates that it is going after the talking machine business aggressively.

"No Records on Approval."

A. B. Miller, Columbia and Victor talking machine dealer at 1124 Sixty-third street, has adopted a rigid "no-records-on-approval" policy, which he says is working out in terms of increased record business. In each of his demonstration rooms appears a placard bearing these statements:

"No records on approval.

"No records exchanged.

"Therefore we can and do guarantee all records."

"After considerable hesitation I adopted this plan last August," said Mr. Miller. "Some of my friends in the trade and many of my customers said that I could not get by with it, but it has proven a success. As a matter of fact, all of my best customers saw the point at once after I had shown them that it was in the protection of their own interests. I have actually got a number of new customers, who have come to my store simply because of the assurance that they will get perfect records. The day before Christmas I sold \$180 worth of records, and not one of them came back. The fact that my record business has been much larger since the adoption of this policy than it has ever been before proves its practicability. Machines from \$50 to \$100 are sold strictly on a ten-

(Continued on page 64.)



Model 150
A Popular Vitanola Style.

VITANOLA—

**The Highest Grade
Talking Machine on the Market
for the Money**

You can travel from Coast to Coast and you will not find—at anywhere near the price—any machine equal to it in tone, design, construction or finish.

And as for the price! Just write us and get a pleasant surprise.

We build special cabinet machines in quantities under your own name and according to your own specifications.

**WE ARE SUPPLYING SOME OF THE BIGGEST PEOPLE IN THE
COUNTRY. WHY NOT YOU?**

Capacity—500 Machines Per Day.

VITANOLA
TALKING MACHINE COMPANY
17 N. Wabash Avenue
CHICAGO

Accidents and Energy Eliminated

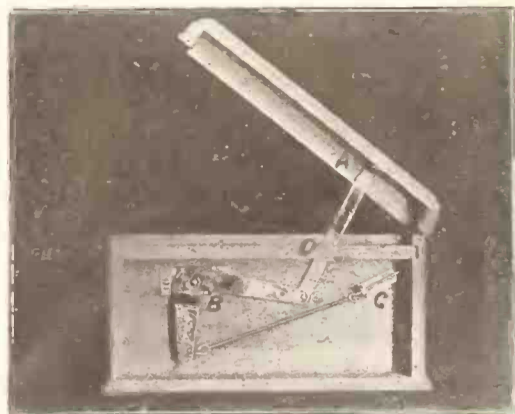

Sectional View Showing How It Operates

No more lifting the cover with care to avoid falling as we have solved the problem of eliminating the weight and balancing it at the same time. Our phenomenal growth proves our claims conclusively.

Read what one of our many satisfied customers says about our Support, then let us satisfy you.

CHICAGO HINGED COVER SUPPORT & BALANCE CO.,
144 South Wabash Ave., Chicago, Ill.

December 6, 1915.

Gentlemen: I consider that the Empire Talking Machine Co. was especially fortunate in being able to present their new Model B machine to the trade with your Cover Support and Balance as regular equipment, and, in my opinion, this is one of our best features, and one that the dealers can use to advantage, because the buyer will be quick to appreciate its many advantages as compared with the old style cover support. With your support the cover can be raised or lowered with one hand, something that is necessary when holding records, and the weight of the cover is entirely eliminated. With all these advantages your device is so simple that there is no chance for it to get out of order, no matter how long or how often it may be used. We are enclosing herewith our additional order for 12,000 sets of your cover supports and trust same will have your usual prompt attention.

Wishing you the continued success which you deserve, and assuring you that we appreciate the manner in which you have handled our orders, I am

Yours very truly,

JOHN H. STEINMETZ, President, Empire Talking Machine Co.

Models will be sent to interested manufacturers. Write today

CHICAGO HINGED COVER SUPPORT & BALANCE CO.

144 S. Wabash Avenue, CHICAGO

FROM OUR CHICAGO HEADQUARTERS—(Continued from page 63).

month basis. There is a little wider leverage on the higher priced machines, but I will not sell a \$150 machine on less than \$12.50 a month, and I insist on at least \$15 a month on a \$200 machine. I will not sell even the cheapest machines at less than \$5 a month. It may seem a little difficult for a dealer to always insist on these terms, but it pays in the long run and eliminates much worry and uncertainty."

Tungs-Tone Needle Soon Here.

One large Victor distributing house made the statement that the long-expected Tungs-tone needle would be delivered in fairly large quantities by the middle of the month.

Following the advertising by the Victor Co. of this new needle, there have been dozens of calls received daily by the downtown retailers, and every one is anxious to secure a supply. It is said that the machines at the Victor factory which have been turning out this product have until recently been limited in number, but are now so greatly augmented as to increase the output sufficiently to make generous initial shipments.

Kimball Department to Move.

On March 15 the talking machine department of the W. W. Kimball Co. will move to the first floor of the new building, and there will occupy temporary quarters consisting of eight private demonstration booths and two large display rooms. When the south half of the new building is completed the department will be moved into it and will prob-

ably occupy a portion of the ground floor on the Wabash avenue side. Manager T. J. Cullen reports that business is keeping up very nicely, with all classes of machines selling in a proportionate degree.

Prepares for Holiday Trade.

P. J. Boller, of the Boller Piano Co., 2168 Milwaukee avenue, is a believer in preparedness. Like numerous other dealers during the last holiday season, he was much disappointed by failures in the delivery of goods, and lost a number of sales. This year he is preparing for anything, and so has erected a special storeroom at the rear of his premises, in which he is collecting a stock of machines. Mr. Boller said to The World: "I am taking no chances and am building this little warehouse, which I am making 42 feet long and 22 feet wide. I hope to have \$10,000 worth of goods stored by the first day of May, and then I know I will be in fair shape for spring; but my July orders of last year have not yet been filled, so on second thought I do not know as I am a bit too early."

Marie Kaiser at Edison Shop.

Miss Marie Kaiser is to make her appearance at the Edison Shop in a tone re-creation test during the week of March 13-20.

Miss Kaiser is a soprano of exceptionally charming voice and has made a rapid rise to the very first class of sopranos in this country. Miss Kaiser has already made two records for the Edison. They are "Italian Street Song" and "Poor Wan-

dering One." She will sing on the evening of March 16 at the warerooms of the Haddorff Piano Co. at Rockford, Ill., and on Tuesday, March 14, she will sing at the establishment of R. K. Kiep, Joliet, Ill.

C. E. Goodwin, manager of the Phonograph Co., returned last week from an overnight visit at Detroit, Mich., where Miss Christine Miller was heard in a tone re-creation test in the ballroom of the Hotel Pontchartrain. Miss Miller sang under the auspices of the Edison Shop.

Wurlitzer Stocks in Good Condition.

Assistant Manager Noble, of the wholesale talking machine department of the Rudolph Wurlitzer Co., says that there has been a remarkable improvement in receipts of machines from the Victor factories at Camden and that large shipments of all styles have been received recently. This applies, according to Mr. Noble, even to the special finishes and styles.

"There seems to be no let-up in business," said Mr. Noble. "The month of February was much better than February of last year, and the demand has increased proportionately. Very fortunately our supplies are improving right along, and there is every indication that our stocks ere long will be nearer completeness than they have been for a long time."

Six Best Sellers.

The six best Columbia records of the month are reported as follows: "We'll Build a Little Home in the U. S. A." and "The Good Old Days Back Home;" "The Old Folks at Home" and "My Old Kentucky Home;" "Memories" and "My Mother's Rosary;" "Waters of Venice" and "Bridal Blushes;" "Casey's Description of His Fight" and "Casey Takes the Census;" and "A Little Bit of Heaven" and "Where the River Shannon Flows."

"M-o-t-h-e-r" remains the big seller in the Victor popular list, with "Wedding of the Sunshine and the Rose" on the reverse side. Other leaders are gems from "Chin-Chin" and selections from "Maid in America;" "Go to Sleep, My Dusky Baby" and "Rocking Time;" "Stop, Look and Listen" (medley fox-trot) and "When Old Bill Bailey Plays the Ukulele." The big sellers in the Red Seal list are "Somewhere a Voice Is Calling," sung by John McCormack, and "Treue Liebe," sung by Alma Gluck and Paul Reimers.

The six best sellers in the Edison list the past

PARTS

If you can't get the
talking machine repair parts
you want, try—

CHARLES BRYAN

25 W. LAKE STREET CHICAGO

Expert repairing for the trade a specialty



Most
Com-
plete

Pathe

Stock in
the
United
States

Promptest Deliveries Best Service Heartiest Co-operation

Address the

PATHE PATHEPHONE COMPANY

17 N. Wabash Avenue, CHICAGO

FROM OUR CHICAGO HEADQUARTERS—(Continued from page 64).

month have been "Back Home in Tennessee" and "M-o-t-h-e-r;" "Bridal Blushes Waltz" and Lake of the Woods Waltz;" "Andante Pastorale," from "Souvenir des Alpes," and "Berceuse-Jocelyn;" "O du mein holder Abenstern" and "Bonnie Sweet Bessie"; "When Irish Eyes Are Smiling" and "Where the River Shannon Flows."

The six best Pathé sellers the past month have been "Celeste Aida" from "Aida" and hymn, "Song of Triumph;" "Thais Meditation" and "Serenade Pechotsch;" "The Chevy Chase" (fox-trot) and "American Greeting March;" "Brown October Ale" and "Oh See the Little Lambkins Play," from "Robin Hood;" "Mazurka 'Chopin'" and "Petite Valse 'Hollmann';" "A Little Bit of Heaven" and "Mighty Lak a Rose."

Now Chicago Talking Machine Co.

The Talking Machine Co. of Chicago, the well-known Victor distributor, has filed notice with the Secretary of State of Illinois for the change of name to the Chicago Talking Machine Co. This has been done simply in order to identify the company more completely with the city in which it is located. The Talking Machine Co. boasts the distinction of being the oldest talking machine concern in Chicago and one of the oldest in the United States. The change, of course, is only one of name, as the organization is exactly the same as in the past. Furthermore, many dealers have always referred to the house as the Chicago Talking Machine Co., so the change in name simply conforms to what has become a quite established usage in the trade.

R. J. Keith, of the Chicago Talking Machine Co., in speaking of the February business said that it was very satisfactory and that it showed a very large increase over the same month of last year. Of course, the machine shortage still exists, notwithstanding the fact that shipments from the factory are greatly in advance of the corresponding period of last year and are coming forward in increasing quantities now. The principal difficulty at present is to get machines in golden oak, while the word from the factory is to the effect that this condition will be rectified in the near future. February was an exceptionally big record month and the company is continually receiving letters from dealers expressing their appreciation of the constructive work of the Chicago Talking Machine Co. and co-operating with them in the systemization of the record business.

Distinguished Visitors.

Louis F. Geissler, general manager of the Victor Talking Machine Co., was a recent visitor to Chicago. He was accompanied by his bride and was on a trip to some of the larger Middle Western centers.

Walter Stahls, comptroller of the Victor Co., and Mrs. Stahls were visitors.

Represent "Perfectrola" in Chicago.

S. M. Bisbee and Walter Kirchwehn have secured the Chicago agency of the Perfectrola talking machine, of Milwaukee, and have established offices at 160 North Fifth avenue, where they have on display a complete line of that make of machines. Mr. Bisbee was formerly connected with

the O'Neill-James Co., and Mr. Kirchwehn is a man of long experience in the trade.

Bright Sayings of Adults.

Riding home I lamps an ad of a phonograph company, which inspires me to say to a pussonal friend of mine: "All these big singers are making a killing warbling for record manufacturers."

"Yep," says p. f., j. l. t., "it's their grand opera-tune-ity."

Stewart Phonograph Co. Busy.

The Stewart Phonograph Co. has received a tremendous volume of orders following the announcement of its \$5 phonograph, published a couple of weeks ago. Orders have been received from every corner of the United States and many from foreign shores, with the result that the company's big plant at Wells street and the river is throbbing with activity. The pressure of the business has put a great strain upon the factory output, but by the use of an increased force and overtime work shipments are being made quite promptly. The popularity of the instrument has already exceeded the fondest hopes of its promoter, and the prediction is freely made that the company has now in sight enough work for at least two years to come.

Wade & Wade Activity.

Wade & Wade, of this city, are receiving many expressions of satisfaction from their trade regarding their new No. 1 fiber needle cutter, which has several new features increasing its efficiency, among which is the fact that the blades work parallel to each other. Both the No. 1 cutter, which retails as heretofore at \$1.50, and No. 2, retailing at \$2, are experiencing a demand that keeps the Wade factory rushed to the utmost.

Lorophone Offices Established.

A. C. Appleton, sales manager of the Lorimer-Hicks Manufacturing Co., of Troy, O., was in Chicago recently, and while here made arrangements whereby the Lorophone Talking Machine Co. will introduce the company's product in four States of the Middle West. In all probability they will be Illinois, Wisconsin, Michigan and Minnesota. The office of the company will be in the State building at the corner of Randolph street and Fifth avenue. The Lorophone is at present being produced in four different models, which have many distinctive features.

Novel Demonstration Device.

The Chicago Hinged Cover Support & Balance Co. is distributing, in response to many hundreds of inquiries for information, a novel device of the shadowgraph variety in the form of a mailing card. It shows just how the Chicago hinged cover support and balance operates and illustrates the changed positions of the lever and the tension of the spring when a talking machine top is raised or lowered. A number of additional manufacturers have included the Chicago hinged cover support in the specifications of their instruments during the past thirty days, and piano bench manufacturers are also planning to use the device.

New Quarters for Pathé Pathephone Co.

Following its recent large increase in capitaliza-
(Continued on page 66.)

WADE FIBRE NEEDLE CUTTERS

Be sure you get
THE WADE

Our absolute guarantee with every
Cutter made

RETAIL PRICES:

No. 1, \$1.50; No. 2, \$2.00

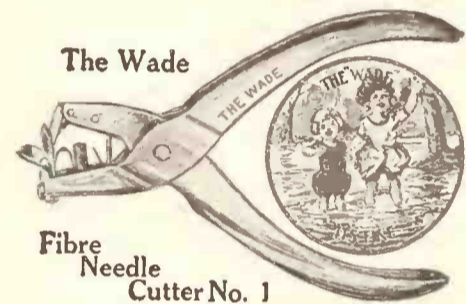

The blades in the Wade Cutters are made from the best tool steel, scientifically hardened and properly ground. With ordinary use they should last indefinitely without sharpening.

The Wade embodies the right principle worked out through long experience. It is simple, durable and accurate. It trims the needle at the proper angle to get the best results.

The Wade is the most economical Cutter. It has a self-acting stop, which prevents waste and enables one to get from 12 to 15 perfect playing points from one Fibre Needle. No. 2 has a double action making it especially easy to operate and affording the most powerful cut of any tool made.

Our service is unsurpassed, a trial will convince you that we can please and satisfy you.

Write for samples and discounts at once.

A Trial is all we ask

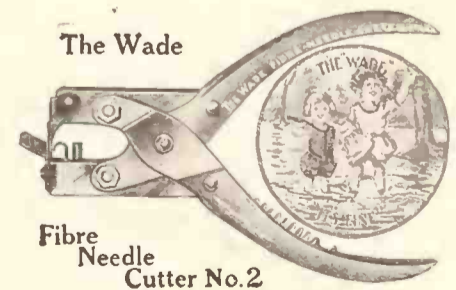

WADE & WADE

3807 LAKE PARK AVE.
CHICAGO, ILL.

The "OROTUND" SOUND-BOX

Equipment furnished to play any disc record, on the popular machines.

The "Orotund" has more exclusive features than any other sound-box and superior results are obtained.

Our claims are: Positively reducing the scratch, metallic, hard, thin, nasal tones and producing rich, mellow, smooth music.

Samples to Dealers—No. 1. "Orotund" only for lateral cut records. \$2.50

No. 2 or No. 3. "Orotund" with jewel and elbow for hill and dale records. \$3.50

Important—Please mention the make of records and the machine on which you wish to use the outfit.

Attractive discounts in quantities.

Combination Attachment Co., 624-626 So. Michigan Ave., Chicago

FROM OUR CHICAGO HEADQUARTERS—(Continued from page 65).

tion and general expansion, the Pathé Pathephone Co. is now removing to larger quarters and has taken over 3,000 square feet on the fifth floor of the same building in which it has been located at 17 North Wabash avenue. The new space is being ideally arranged, both as a distributor's office and retail salesrooms. In addition to the general offices, record stockrooms, etc., there is a large reception room, where the entire Pathé line is placed on display, the concert hall and four individual demonstration booths. All of these are being tastefully decorated and very comfortably furnished, so that the Pathephone Co. is now equipped to serve with equal comfort either its retail patrons or its dealers.

Office Manager Frank Tooley has instituted an entirely new office system, which makes for improved facilities for handling wholesale orders and for shipments that involve the minimum of delay. In conjunction with General Manager R. E. Rundell, Mr. Tooley is also arranging for a largely increased stock of records. The company has also perfected a new selling scheme which is said to be entirely new and remarkably effective. The company is affording its dealers supplementary service, which unfortunately cannot be explained here.

"The month of February was the best wholesale month in our history," said Mr. Rundell to The World. "This is due in part to our ability to furnish dealers with the records which they order, and this department has been vastly improved. A number of good local agencies have been arranged by our city salesman, Edward Bristol. Perhaps one of the latest of our out-of-town dealers is the firm of Clemenn & Salzman, of Rock Island, Ill."

Personals and Visitors.

Edward Rice, of the Schiller Piano Co., of Davenport, Ia., was in the city last week, accompanied by his wife. They have just returned from a month's trip to the South, a feature of which was a delightful journey along the Florida coast in a fine yacht owned by Chicago friends.

Miss Douglas, formerly of the talking machine department of Marshall Field & Co., is now with the P. A. Starck Piano Co.

Miss Kiley, for some years with the Siegel & Cooper talking machine department, has accepted a position with the new Sonora store on Jackson Boulevard.

H. B. Levy, Vocalion representative of the Aeolian Co., who makes his headquarters in Chicago, has been on a number of short trips through neighboring States, and in all of them was met with a very encouraging reception.

F. L. Bernard, of Springfield, Ill.; H. G. Kramer, Crown Point, Ind., and E. A. Vaughan, Princeton, Ill., were recent visitors to Chicago. The last-named gentleman recently conducted a campaign in the public schools of Princeton and sold three good-sized machines in the lower grades. He is planning next to equip the high schools.

Mr. Schoonmacher, the new manager of the talking machine department of the Herzfeld-Phillipson Co., of Milwaukee, was in Chicago a few days ago.

Henry Linnig, of Linnig Bros., Peru, Ill., and Orison Young, Grand Forks, N. D., were two visiting dealers this month.

H. W. Main, manager of the talking machine department of Locke & Kuhl, Peoria, Ill., was in Chicago for a few days recently.

Arthur D. Geissler, of the New York Talking Machine Co. and the Chicago Talking Machine Co., spent a week in Chicago and returned to New York with Mrs. Geissler, who had been spending some time with relatives here.

Robert B. Gregory, president of Lyon & Healy, is at Bellaire Heights, Fla.

George Joosten, of Jansen & Joosten, Peoria, Ill., and A. H. Renier, of La Crosse, Wis., were recent visiting dealers.

J. G. Corley, Richmond, Va.; E. W. Hanson, Oelwein, Ia.; J. W. Sturgis, Hugo, Okla.; W. H. Sweetland, Otsego, Mich.; W. H. Aton, Baraboo, Wis.; F. R. Willey, Shelby, Ill.; A. V. Lyle, Beloit, Wis., and E. G. Olson, Wichita, Kan., were recent visiting dealers to the local trade.

Julius Friedrich, Jr., of the Friedrich Music House, of Grand Rapids, Mich., was in the city recently and visited the leading talking machine stores and departments with a view of getting ideas for extensive improvements to be made in their talking machine department. It is to be moved from the third floor to the ground floor and eight handsome demonstration booths built.

Leonard Bros., furniture dealers of Rantoolle, Ill., have qualified as Victor dealers.

W. T. Duker, proprietor of a large department store at Quincy, Ill., was in the city recently visiting his daughter, who is attending the Anne Morgan School of Expression here. Mr. Duker installed a Victor department in October and a few weeks ago bought the entire Victor stock of the Ware-Weyland Co., of the same city.

Word has been received in Chicago to the effect that Don Preston, manager of the M. S. Donaldson department store at Minneapolis, is the father of a fine girl who is already giving evidence of marked musical proclivities. Prior to assuming his present position Mr. Preston traveled for the Chicago Talking Machine Co.

West & Neuhaus, dealers in electrical goods at 125 West Madison street, have added a Columbia department, which is in charge of E. W. Richards, formerly of the sales force of the Grafonola Shop on Michigan avenue.

The Magniphone Now on Market.

A. L. Eaton, of the American Can Co., announces that his concern is now placing upon the market the company's all-metal machine, which is known as the "Magniphone."

Knabe-Crystola on Display.

Al Bruckner has opened a salesroom and office

on the eleventh floor of the Republic Building, where he is now promoting the Knabe-Crystola machine. Mr. Bruckner has had wide experience in advertising and sales promotion.

Buys Music Store.

George P. Cheatle, the well-known representative for the Chicago Talking Machine Co., has, with his father and brother, purchased the Bernard Music House at Springfield, Ill., and it will be known in the future as the "Music Shop." Mr. Cheatle will have a third interest in the business and will give the others, who will be actively in charge, the benefit of his experience in the talking machine business, but will devote his time to the interests of the Chicago Talking Machine Co., as in the past. Pianos and sheet music will be handled in addition to Victor talking machines and records.

Complete Stock of Repairs.

Charles Bryan, of 25 West Lake street, has built up an unusually large business on talking machine repair parts of all kinds, and is scoring handsome increases from month to month on account of the excellent service he is able to give his trade. Not only is he able to furnish parts for all the established present machines, but has frequent inquiries for parts of the old Talkophone, Hawthorne-Sheble, Zonophone and other machines.

ENTER THE "MUSICTROLA."

Name Adopted for New Talking Machine Manufactured by Passow & Sons and Which is Meeting with Marked Success.

(Special to The Talking Machine World.)

CHICAGO, ILL., March 8.—Passow & Sons, of 832-842 West Madison street, Chicago, have adopted the name "Musictrola" for the new talking machine which they placed on the market last month. They now have ample stocks of the various models and have large quantities coming through their extensive factory. They are, therefore, able to fill all orders promptly. They have already established a number of desirable dealers and are receiving particular recognition of the merit of the "Musictrola" in the number of repeat orders which they are constantly receiving. Passow & Sons' methods are worthy of admiration, as they are only placing their line with responsible dealers and under conditions calculated to secure them adequate and high-grade representation. Moreover, they are endeavoring to conduct their business in line with the best traditions of the talking machine trade. The line at present consists of three attractive styles of cabinet machines, retailing at \$75, \$100 and \$150, and are distinctive because of the excellence of the cases, the result of forty-five years of experience in producing cabinet work of the highest quality. The machines are all equipped for playing any disc record, have an excellent motor, efficient tone regulator and other desirable features.

A DEALER WRITES A LETTER—

"MR. JOHN H. STEINMETZ,
Pres. EMPIRE TALKING MACHINE CO., Chicago, Ill.

Dear Mr. Steinmetz:

The Empire has arrived!—What impression did it make on me, and what is my opinion?
In all my writings to you, I have been 'outspoken,' no 'flowery' talk. So I will tell you frankly, also, in this case
After giving the machine several tests and the minutest examination, I have found the following:
That the Empire Talking Machine is ahead of ANY OTHER machine on the market;
That its manipulation is more convenient and easier than any;
That it plays all records equally well;
That the spring-balanced cover is a great advantage;
That the Tone-modifier is simply great and much appreciated by all that saw it demonstrated;
That the appearance of the Empire \$100 model is, at least, equal to that of most \$150 models;
That there should be the greatest of success in store, in the very near future, for the Empire;
That I will knuckle down and push and pull and lift and work and use every legitimate effort for the success of the Empire,
its head and sub-promoters and distributors (may I include myself?).
The 500 circulars, with address, have arrived and have started work for the Empire at once. What the result will be and how soon will only be seen in the future. Will also start the advertising in local papers now, and otherwise do all I can to further the distribution.
Yours very truly,
(NAME UPON APPLICATION)

For complete information concerning the Empire line, catalog and outline of our co-operative service for dealers, write us direct.

Empire

Talking Machine Co.

429 S. WABASH AVENUE, CHICAGO

JOHN H. STEINMETZ, Pres.



Model B—\$100.



Jobbers of the Pathephone

Secure the agency for the best selling musical instrument manufactured.
Write us concerning contract. Largest Stock. Best service.

E. E. TROWER MUSIC CO., St. Joseph, Mo.

PATHEPHONE ON STATE STREET.

New Store Opens on Main Thoroughfare in Chicago—Furnishings Cost Thousands.

(Special to The Talking Machine World.)

CHICAGO, ILL., March 6.—The State Street Pathephone Co., on the first of March opened what is in many ways one of the most remarkable retail stores in the world. It is remarkable mainly for its location, which is at the northeast corner of State and Monroe streets, on the first floor of the Mentor Building. The space occupied measures 27 feet on State street and 50 feet on Monroe street, and is conceded to be one of the choicest corners on what is acknowledged to be the best retail merchandising street in the world.

The lease calls for an annual rental of \$25,000 per year for a term of five years, or \$125,000 in all. There are thirteen private demonstration booths in all, built around a central corridor and around a mezzanine balcony. There is also a large reception room immediately inside of the State street entrance.

Facing the entrance and parallel to it is a corridor, which leads to the main floor demonstration booths, and the mezzanine booths are located immediately above. The cost of the work runs into several thousand dollars, and the furniture will also cost a similar sum. The venture is being handled by Arthur J. O'Neill and his two sons, Harry K. O'Neill and Arthur D. O'Neill, which family has been identified with the Pathephone since its introduction in this country. The company has been incorporated with a capital stock of \$10,000.

The number of persons passing this point is estimated at almost 250,000 per day, and the O'Neills believe that it is just as practicable to sell talking machines under these conditions as it is to sell cigars or clothing.

APPRECIATIVE OF SERVICE.

Policy of Empire Talking Machine Co. Wins Response from Dealers.

(Special to The Talking Machine World.)

CHICAGO, ILL., March 7.—One of the phases of the talking machine business to which the Empire Talking Machine Co. has paid a good share of

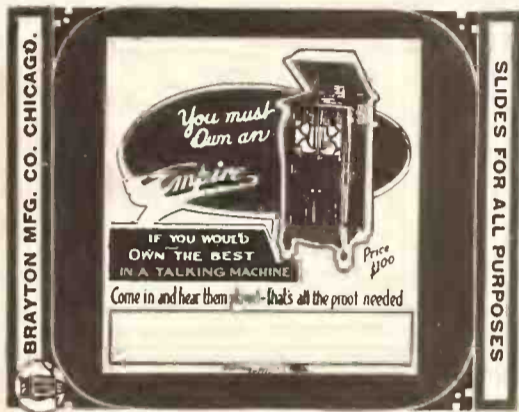

Reel Exploiting the Empire.

attention is that of its service to dealers. As a part of this co-operation dealers are furnished with cuts, advertising matter, lantern slides, etc.

The accompanying illustration shows one of the typical lantern slides which are used by Empire dealers through the medium of the motion picture show to familiarize their communities with the Empire machine.

That the results are being produced is testified to by a number of dealers who have written to Mr. Steinmetz, president of the concern, voluntarily expressing their appreciation of the aid which they have received.

Lots of folks pray for good times, but forget to ask for strength to stand prosperity.

DOYLE CO. FEATURING TALKERS.

Enterprising Furniture House Carries Both Victrolas and Grafonolas.

(Special to The Talking Machine World.)

GALESBURG, ILL., March 6.—The Doyle Furniture Co., at Main and Seminary streets, is featuring the Victor and Columbia machines, and recently used a full page ad in the local paper to call attention to the resourcefulness of the talking machine as a means of entertainment. A full line of Victor Victrolas and Columbia Grafonolas is carried by this firm, and a complete supply of the records made by both companies is also in stock. A special feature of the record department of the Doyle Co. is its mail order department, whereby any record ordered is delivered to the customer, through parcel post, within forty-eight hours after the order is received. Every customer of the store is sent the monthly supplements of the new records as they are issued, and by giving careful attention to these details of service it has built up an enviable trade in talking machines in Galesburg and vicinity.

THE WORLD SELLS ITSELF.

GREENVILLE, KY., February 26, 1916.

Editor Talking Machine World, New York.

Dear Sir—We received yesterday the sample copy of your journal, and our opinion is best expressed in the remittance enclosed for a year's subscription. We have gone over this number pretty thoroughly and with great satisfaction, and are anticipating great pleasure and benefit from the continued visits of this excellent journal. With every good wish for your greatest success, we are, sir,

Very truly yours,

THE J. L. ROARK ESTATE,
Orien L. Roark, Manager.

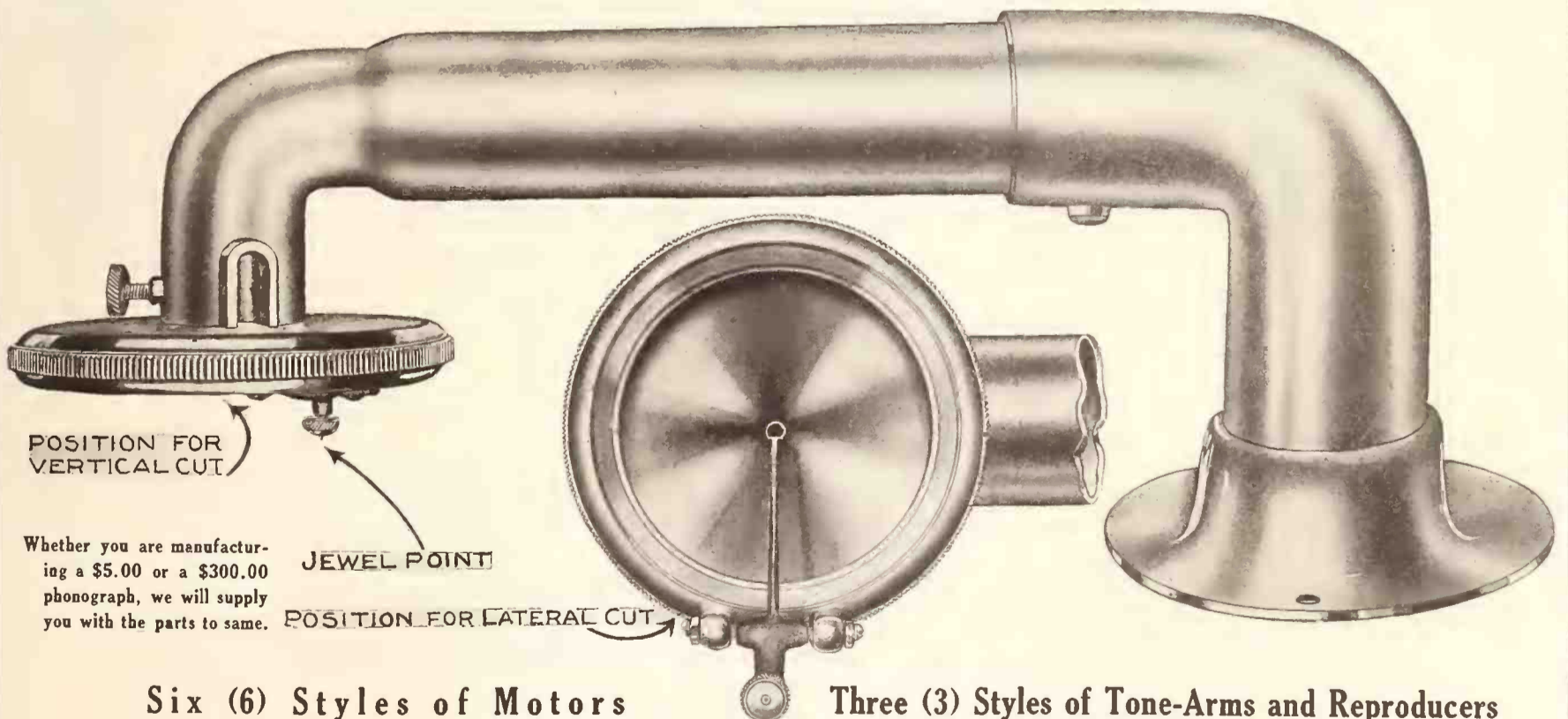

Six (6) Styles of Motors

Three (3) Styles of Tone-Arms and Reproducers

READY FOR DELIVERY

Our famous No. 1, complete outfit, consisting of motor playing nearly two 10" records, top regulation, with 10" turntable; reversible tone-arm, with sun-rayed diaphragm sound-box, at \$2.50, for quantity users.

Independent German-American Talking Machine Co., Inc.,

56 BLEECKER ST.
NEW YORK

DEALERS WANTED

IN EVERY CITY, TOWN OR VILLAGE TO SELL OUR

HIGH CLASS

“MUSICTROLA”

The Phonograph That Plays
All Makes of Records Perfectly

Has no rival for Quality of Tone, Durability of Motors, Practicability of Construction and Beauty of Design and Finish.

The Tone Regulator will play Loud or Soft Tones without closing any doors or shutters.



No. 110

FOR TONE QUALITY
IT HAS NO RIVAL

**BIG PROFITS AND DISCOUNTS
TO DEALERS**

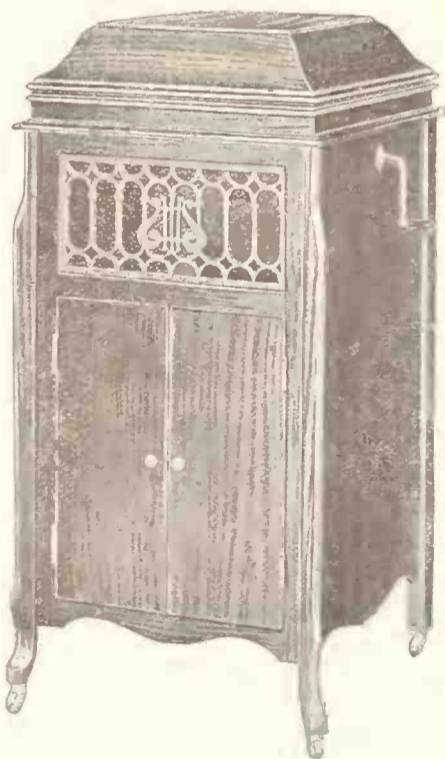

No. 110

List Price, \$75.00

SIZES—42 in. high, 19 in. wide,
23 in. deep, 12 in. Turntable.



No. 111

List Price, \$100.00

SIZES—44 in. high, 21 in. wide,
24 in. deep, 12 in. Turntable.



No. 114

List Price, \$150.00

SIZES—48 in. high, 23 in. wide,
25 in. deep, 12 in. Turntable.

MADE IN GENUINE SELECTED MAHOGANY or QUARTER-SAWED OAK

WE GUARANTEE YOU that we will refund every cent of your money where goods are received exactly as ordered and represented but for some reason they are not fully satisfactory to you, providing however, that all goods are returned to us at Chicago within ten days in good condition, free of all transportation and cartage charges.

PASSOW & SONS 832 to 842 Madison St.
CHICAGO

Established 1871



Looking back a couple of years will give you the Columbia idea. Looking ahead a couple of months will give it to you better.



(Write for "Music Money," a book "full of meat" for those dealers interested in quick and frequent turnover of capital.)

Columbia Graphophone Company
Woolworth Building, New York

WITH THE TRADE IN PITTSBURGH.

Talking Machine Department of Rosenbaum Co. Being Removed to New Location—H. H. Buck a Benedict—C. F. Newman in Charge at Boggs & Buhl—Other Changes—Trade Generally Active During Past Month.

(Special to The Talking Machine World.)

PITTSBURGH, PA., March 8.—The talking machine department of the Rosenbaum Co. is being removed from its original location on the ninth floor to the third floor, where entirely new equipment has been installed. The department is among the best in the city, its home being in the newest and finest of Pittsburgh's department stores. It was established a little less than a year ago, when the store was completed, and has proven a marked success. The Columbia line has been carried exclusively up to the present time. With the establishment of the department in its new location, the Edison line has been acquired and will be featured along with the Columbia. Several new additional booths have been installed and the new quarters are being fitted up in a very attractive manner and along the most up-to-date lines.

H. H. Buck, manager of the Rosenbaum talking machine department, was married on February 12 to Miss Edith Abrams, of this city. Mr. Buck is well known in the trade, having occupied an important position with the Columbia Graphophone Co. for a number of years before taking charge of the Rosenbaum department. Miss Abrams had been associated with Mr. Buck in the department since last September.

The Boggs & Buhl talking machine section is now under the direct supervision of C. Frederic Newman, who was recently appointed manager of the piano department. Mr. Newman reports an

excellent volume of business in both Victor machines and records.

The Buehn Phonograph Co., Inc., jobbers of the Edison talking machine in this district, are now well established in their handsome new home at 513 Wood street, which was opened last month. The store is now completely furnished in an artistic and luxurious manner throughout. Mr. Buehn reports business very satisfactory and a good number of new Edison dealers in this territory.

The talking machine department of the Schroeder Piano Co. is doing a phenomenal business, Henry F. Schroeder reports. In making a conservative estimate of the improvement over last year, Mr. Schroeder states that the sales of records have increased 30 per cent. and of machines 15 per cent. The Columbia line is handled exclusively.

H. N. Rudderow, manager of the Talking Machine Shop, Jenkins Arcade Building, reports business continuing at a fine level of activity. The Talking Machine Shop gives daily Victrola concerts that have been attracting considerable attention.

George Hards, manager of the W. F. Frederick Piano Co.'s talking machine department, states that trade in the Victor line has reached splendid proportions this month, and that all the machines obtainable are being sold.

Mrs. C. H. Walrath, formerly in charge of the offices of the Kaufmann Bros. piano department, has joined the talking machine section of the "Big Store" as associate to M. Max. Mr. Max, who is also Eastern manager for the Symphony Player Co., New York, N. Y., has spent the greater part of the past month here looking after the large volume of business being handled by the department.

A State charter of incorporation was granted at Harrisburg on March 3 to F. C. Wampler & Son Inc., dealers in Victrolas and pianos at 510 Walnut street, McKeesport, Pa. The capital stock is stated at \$25,000. The incorporators were: W. P. Wampler, Harriet C. Wampler and Natalie Schaffer, all of McKeesport.

The Columbia Graphophone Co. has appointed W. D. Montgomery as manager of the sales force in the city and surrounding towns. Mr. Montgomery is a talking machine man of considerable experience, having been previously associated with the Columbia Co. in Pittsburgh for about three years.

CENTURY CO.'S NEW CATALOG.

The Century Cabinet Co., 25 West Forty-fifth street, New York, has just issued a new catalog illustrating the popular models in its extensive line of phonograph cabinets. This catalog is well illustrated and attractively arranged, representing the artistic character of the cabinet designs manufactured by this company.

During the past few months the Century Cabinet Co. has arranged to manufacture cabinets for some of the leading talking machine manufacturers in the country. The company is well equipped to take care of all of the work, as it maintains a very large factory which is up to date in every particular. In addition to carrying a standard set of designs, the Century Cabinet Co. will produce any special cabinet designs which a manufacturer may desire.

The G. A. White Piano Co., of Fairbury, Neb., recently completed four handsome new music rooms in its store, which will be used principally for Victrola demonstrations.

Are You Prepared?

¶ To handle your 1916 Victor trade profitably you will need the co-operation of a Victor jobber who specializes on solving the problems which daily confront the Victor dealer. Such problems as stock, advertising, turn-over, etc., are all included in the

G. T. Williams Service!

¶ This organization is equipped to give Victor dealers practical assistance in developing their business along sound, logical lines.

¶ A trial order will convince you that the word SERVICE means more to this company than any dictionary definition.

Why not learn our definition?

G. T. WILLIAMS CO., Victor Wholesale Exclusively, 217 Duffield St., Brooklyn, N. Y.



SAVOY—Style 65
Retail at **\$65**

Mahogany, Highest Grade Finish. Size, on Casters, 48 Inches High, 22 Inches Wide, and 23 Inches Deep. Double Spring Wormgear Motor, 12-Inch Turntable.

Biggest Values on the Market

**S
A
V
O
Y**



SAVOY—Style 25
Retail at **\$25**

Mahogany, Highest Grade Finish—Size 18½ Inches Wide, 14 Inches High and 22 Inches Deep. Double Spring Wormgear Motor, 12-Inch Turntable.

Savoy Gramophones are equipped to play ALL makes of Records without a change of sound box or use of any attachment.—Write for special proposition.

**Nanes Art Furniture Co. Grand Street and East River
:: :: NEW YORK :: ::**

EXECUTIVE BOARD OF TALKING MACHINE JOBBERS MEETS.

Executive and Legislative Committees of the National Association of Talking Machine Jobbers Convene—Convention to Be Held in Atlantic City Early in July.

A very busy and resultful meeting of the executive and legislative committees of the National Association of Talking Machine Jobbers was held on Tuesday, February 15, at the Hotel Knickerbocker, New York, with a very satisfactory attendance of committeemen and jobbers in general.

A meeting of the executive committee was held in the morning, at which a number of association and general business affairs were discussed and at which a committee of three, consisting of J. F. Bowers (chairman), P. B. Whitsit and C. F. Bruno, was appointed to attend the meeting of the allied trades on Wednesday for the discussion of the plan for the formation of a Music Trade Chamber of Commerce.

Another committee, consisting of J. N. Blackman, W. H. Reynolds and J. C. Roush, was appointed to visit the Victor Co. factory in Camden and discuss various trade matters with the officials of that company.

A vote of thanks was tendered J. N. Blackman for his prompt action in sending the condolences of the association to the family of the late Col.

Edward Lyman Bill at the time of his death, and a committee, consisting of J. F. Bowers, Louis Buehn and H. A. Winkelman, was appointed to draw up formal resolutions of condolence and regret.

The dates for the coming annual convention of the association were fixed as July 10, 11 and 12, at the Hotel Traymore, Atlantic City, a favorite rendezvous of the jobbers. The plans call for a three-day convention, the first two days being devoted to business sessions and the third day to educational work and other pertinent subjects.

At the afternoon session the legislative committee had the floor, the committee consisting of Messrs. Mickel, Roush, Bowers, Nestor, Whitsit, Blackman and Rauth. The work of the committee in support of the Stevens Bill for the maintenance of prices on trade-marked goods was highly commended, and arrangements were made for the collection of the last half of the assessment levied upon association members to carry on the work.

In further support of the Stevens measure, the legislative committee went to Washington in a

body the latter part of the week and spent Friday and Saturday in the National Capital working with the Congressmen in support of the bill.

Those present at the meetings included: H. F. Miller, Penn Phonograph Co., Philadelphia, vice-president, who presided in the absence of President A. G. McCarthy; W. H. Reynolds, Mobile, Ala., treasurer; E. C. Rauth, Koerber-Brenner Co., St. Louis, secretary; George E. Mickel, Nebraska Cycle Co., Omaha, Neb.; J. F. Bowers and L. C. Wiswell, Lyon & Healy, Chicago; A. A. Trostler, Schmelzer Arms Co., Kansas City, Mo.; H. A. Winkelman, Oliver Ditson Co., Boston; Louis Buehn, Philadelphia; French Nestor, W. F. Frederick Piano Co., Altoona, Pa.; C. F. Bruno and H. Stadlmair, C. Bruno & Son, New York; F. P. Oliver and J. N. Blackman, Blackman Talking Machine Co., New York; Perry B. Whitsit, Perry B. Whitsit Co., Columbus, O.; J. C. Roush, Standard Talking Machine Co., Pittsburgh, and H. G. Koerber, Koerber-Brenner Co., St. Louis.

KOERBER-BRENNER CO. ACTIVE.

(Special to The Talking Machine World.)

St. Louis, Mo., March 8.—General business with the Koerber-Brenner Co., the prominent Victor distributor, has been thoroughly satisfying during the past month, the volume of orders taxing the company's ability to meet them with deliveries made from the Victor factory. There is still a shortage on certain types of machines, but through careful distribution the burden of stock shortage does not fall too heavily upon the shoulders of any one group of dealers.

H. G. Koerber, president and treasurer, and E. C. Rauth, vice-president and secretary of the company, spent several days in the East last month, attending the meeting of the executive committee of the National Association of Talking Machine Jobbers, of which Mr. Rauth is secretary, in New York, and going later to the Victor factory. Both gentlemen came back to St. Louis full of enthusiasm regarding the future line and particularly the outlook for 1916.

Do you need capital to increase your business?

We will pay you cash for acceptable installment contracts on Talking Machines and Pianos.

WRITE FOR DETAILS

HAMILTON INVESTMENT CO., 76 W. Monroe St. CHICAGO, ILL.

GENERAL IMPETUS TO CLEVELAND TALKER TRADE.

Business Shows Considerable Activity for Various Reasons—Demand for Goods Still Exceeds the Supply—Talking Machine Men Attend Annual Banquet of Music Trade Association and Make Speeches—What the Various Houses Have to Report.

(Special to The Talking Machine World.)

CLEVELAND, O., March 8.—During the past month the talking machine industry in this city has experienced an exceptional impetus, due to various causes. The Cleveland Music Trade Association held its annual banquet on February 24 at the Colonial Hotel, this city, and as the talking machine men were recently taken into the association there was a large coterie on hand, and two prominent talking machine men, namely, C. K. Bennett, manager of the Eclipse Musical Co., and George R. Madson, manager of the Columbia Graphophone Co., were among the leading speakers. Mr. Bennett spoke eloquently on the importance of the passage of the Stevens Bill and Mr. Madson spoke on the subject "Has the Talking Machine Increased Interest in Music?"

The Victrola department of William Taylor, Son & Co., under T. A. Davies' management, reports a phenomenal month's business, and the business for February, 1916, showed an increase of 90 per cent. over the same month a year ago. Not a single sale of a machine has been lost because of shortage of stock.

C. H. Denslow, formerly of the Eclipse Musical Co., and William Bregenzer, formerly of the W. F. Frederick Piano Co., helped materially to achieve the wonderful results attained.

The Phonograph Co., exclusive Edison jobber, again showed a substantial increase over last year's business, and Secretary L. N. Bloom was elated over the month's results. Many tone tests have been made throughout the entire territory, and the publicity campaign has been most successful. The demand seems to be for the higher priced instruments.

March finds the Euclid Music Co. prosperous and doing well. Grant Smith, secretary and treasurer of the company, stated it was the best month in the history of the store. James Card is president of the company and a Rotarian, and he had the rare treat of having Harry Lauder address him before 500 Rotarians gathered for a noonday lunch at the Hotel Statler, this city. "Jimmie, my lad, my new Rotarian song will be out soon on a record, and be sure and sell every Rotarian one; and mind ye now, Jimmie, be sure ye get your money." Mr. Card has, in addition to his present store, procured the rights to open a store in Lakewood, O. and will be known as the Lakewood Music Co., opening April 1, handling the Victrola line exclusively.

The B. Dreher's Sons Piano Co., sole Cleveland representative for the Aeolian-Vocalion, reports that business for the past two months with the Vocalion and Columbia Grafonola was equal to that of the first six months of 1915 business. W. G. Bowie, manager of the department, just returned from his visit to the Aeolian factory in Long Island. After his trip he was more enthusiastic than ever over the Vocalion and reported seven sales shortly after his return.

The J. T. Wamelink & Sons Piano Co., prosperous Columbia Grafonola dealer, reports a good increase in business. S. Tonnsley, who has been affiliated with the different branches of the talking machine industry during the past six years, is in charge of the department.

Harry J. Wamelink, manager of the J. T. Wamelink & Sons Piano Co., was recently elected president of the Cleveland Music Trade Association.

The Diamond Disc Phonograph Co. states that

A GOOD WAY TO RUIN RECORDS.

Experiment Suggested by Monthly May Demonstrate the Value of the Human Skull as a Sound Box but Will Not Improve Records.

According to a writer in the Electrical Experimenter, the human skull makes a fine talking machine sound box or reproducer, and offers the following formula for discovering if one's particular skull is of the particular material that carries sound:

"Stop up both of your ears with cotton as tightly as possible, so that no sound will be heard from the outside. Now place an ordinary darning needle between your teeth by biting on it hard, taking care that the lips or tongue do not touch the needle. The latter is important, because if either lip or tongue touches the needle the sound will be decreased considerably.

"For the best results the needle itself should project not more than one or one and one-half inch from the mouth. For that reason the darning needle should be broken off about one and one-half inch from its sharp point. It goes without saying that the sharp point should project out of the mouth, while the broken off end should be inside the mouth.

"Now start an ordinary disc phonograph and carefully press down upon the record with the needle's point held at the same angle as the reproducer's needle is held ordinarily. With a little

February business evened up with that of January, and especially the sale of the new records. The company features the new Edison lists with the new artists, and Manager E. A. Friedlander says that the new and excellent Diamond Disc recordings have proved exceptionally popular during the past month.

The Columbia Graphophone Co. has again eclipsed the results from business of a year ago, and Manager George R. Madson reports that he had to have more space on the same floor of the Kinney & Levan Building.

The Eclipse Musical Co., extensive jobber of Victrolas, reports that the demand for goods at present is greater than it was during the holiday season, and the Style XI Victrola is very scarce. E. B. Lyons, assistant manager of the company, made a trip through the territory, and reported that everywhere business was booming.

R. A. Alpers, formerly with the Slocum Piano Co., is now on the road for the Fischer Piano Co., jobber of the Pathé Pathephone.

Recent visitors in this city were: Mr. Laurie, auditor of the Columbia Graphophone Co., New York; Charles Logan, of the W. D. Andrews Co., Buffalo, N. Y., and William Maxwell, vice-president of Thomas A. Edison, Inc., Orange, N. J.

practice one will become proficient in moving the head at the same ratio of speed as the ordinary reproducer arm is moved from the outside of the record toward the inside. As soon as the needle touches the record with sufficient pressure the inside of the head will be filled immediately with music exceedingly loud and clear.

"A curious result of the experiment is that a person standing near by can hear the music, the head acting as a reproducer in this case."

THRIVING PORTLAND DEPARTMENT.

(Special to The Talking Machine World.)

PORTLAND, ORE., March 1.—Henry Jennings & Sons, the prominent furniture dealers of Portland, Ore., who installed a complete Columbia Grafonola department in December, are building up a splendid business with this line, which they are handling exclusively. The Jennings store is one of the largest devoted to furniture in the Northwest and occupies a quarter of a block, five stories high, in one of the best locations of the city. They are making very attractive window displays of Grafonolas these days.

The Homlyke Phonograph Parlors, at 113 South Main street, Ann Arbor, Mich., were recently opened, a large crowd of visitors attending the opening demonstrations and concerts. The new store is owned by A. S. Lyndon and is under the management of C. E. Stevens.

**EFFICIENT
RECORD
SERVICE**



**ORDERS
FILLED
PROMPTLY**

Jobbing Victor Product Exclusively

ECLIPSE MUSICAL CO.

**Victor Distributors
CLEVELAND**



Stewart

PHONOGRAPH

The Stewart Phonograph will soon be in the homes of millions.

Why not let your store supply every family in your neighborhood?

This phonograph places within the reach of all the latest and most up-to-date phonograph.

It plays disc records of all sizes—the largest and the smallest.

Many higher priced phonographs do not give a finer or truer reproduction. It is natural, clear, and beautiful.

\$5

Already there is an enormous demand for the Stewart Phonograph.

Hundreds of thousands of dollars will be made selling the Stewart Phonographs in your territory.

Every music and phonograph store—you—can get a good big share of these profits by securing representation at once as one of our dealers.

To those who write immediately, we can make a very attractive proposition.

Use the coupon on opposite page or write a letter. Do it now.

A Big Money Maker for Music and Phonograph Stores

A Beautiful, Practical Phonograph at \$5

Here is the opportunity of your lifetime.

The Stewart is the phonograph the whole world has been waiting for.

It gives to millions of people the first opportunity to satisfy that great longing to hear and enjoy all of the world's best music at a price they can afford.

It gives you a great big opportunity to make money.

Every person who comes into your store is a logical prospect for a Stewart Phonograph.

The only reason they do not already own one is because never before have they been able to buy

a beautiful and practical phonograph at a price within reach of the average purse.

We will still further increase the extensive and established market by conducting a big, aggressive, national advertising campaign.

The first of the advertising series is appearing in the national magazines right now.

Our large sales and advertising co-operative work will create a huge volume of business right in your town.

Why not be a Stewart dealer and get your share of the profits?

Write at once. First come—first served. Use the coupon.

The Achievement of the Century

The Stewart, a practical phonograph at \$5, is the achievement of the century.

It plays all records—the highest priced and the lowest priced—the largest and the smallest.

Play one in the same room with any other phonograph, and we defy anyone to tell the difference in the quality of music reproduced.

The Stewart Phonograph is new in design. It is all metal. Cylindrically shaped beautifully proportioned, finished in dull black lacquer, the tone arm and trimmings in highly polished nickel, the Stewart is an ornament to the finest home.

It combines the latest and most improved features of phonograph construction.

Stewart—A Famous Name

The name Stewart is already famous throughout the entire civilized world. Nearly every automobile is equipped with one or more Stewart products—the Stewart Speedometer, Stewart Vacuum System, Stewart Warning Signal, etc.

Stewart products are built by the largest

manufacturers of automobile accessories in the world. Ninety-five per cent. of all automobiles are equipped with Stewart products and we sincerely believe that in a very short time ninety-five per cent. of all the American homes will be enjoying a Stewart Phonograph.

Use this coupon or write a letter:

<p>Coupon for</p> <p>Dealer Representation</p> <p>The Stewart Phonograph Corporation 341 Wells Street, Chicago, Illinois</p> <p>Gentlemen:— I am interested in the business possibilities of the Stewart Phonograph. Please send me information giving the details of the proposition you are willing to make to dealers.</p> <p><i>My business is that of.....</i></p> <p>Name.....</p> <p>Street Address.....</p> <p>City.....State.....</p>	
--	--

The Stewart Phonograph Corporation, 341 Wells Street
Chicago, Ill., U. S. A.



Judging from the thousands of sales of Oscar Seagle records that have already been made, the announcement of two new recordings by this artist in the April Columbia list will be particularly gratifying to *Columbia* dealers.



(Write for "Music Money," a book "full of meat" for those dealers interested in quick and frequent turnover of capital.)

Columbia Graphophone Company
Woolworth Building, New York

VISITING ARTISTS STIMULATE SALES IN DETROIT.

Strong Demand for Records Follows Appearance of Leading Singers and Instrumentalists—Local Talking Machine Association Prospering—Columbia Co.'s Branch to Move on April 1—Edison Tone Test Recitals Secure Attention—Big Order for Cabinets.

(Special to The Talking Machine World.)

DETROIT, MICH., March 7.—Everything seems to be moving along very satisfactorily in the talking machine business so far as Detroit is concerned. Retailers are selling loads of machines and records and deliveries are coming along better than they have for many months. The jobbers are very well pleased over conditions because both ends of their business are good—deliveries and orders. The fact cannot be denied that the talking machine business has been stimulated during the past few months by the number of prominent musical artists who have given recitals in Detroit—such as Frieda Hempel, John McCormack, Paderewski and others. Especially is this true of the record departments. The special window displays of both Grinnell Bros. and the J. L. Hudson piano store in honor of John McCormack's appearance in Detroit were very attractive and unusual—and they sold a lot of McCormack records. This demonstrates the value of proper window displays—in keeping with what is going on in the musical world.

The Detroit Talking Machine Association is prospering, and the membership increasing. For a new organization there is more than the ordinary amount of co-operation—everybody is boosting and everybody is glad of the organization. It cannot

fail to be a great success. The March meeting was held at the Hotel Cadillac.

The Columbia Graphophone Co.'s local branch will move about the first of April to a new location at 400 Woodward avenue, where it will occupy the entire second floor of the new Walker building. Here the company will do a wholesale business only—doing away entirely with its retail department. The new location has three times as much floor space as the Broadway store, and will be arranged to suit the particular needs of the business. The building itself is new and everything in the Columbia store will be new.

There is a lesson to be learned in the slogan adopted by a new Detroit bank—"The Bank That Always Says 'Thank You.'" This should be taught to every sales person in the talking machine business. Courtesy is one of the greatest assets in selling the public. Every talking machine store should adopt the "courtesy" slogan.

Under the auspices of the new Edison Shop of Detroit a recital by Miss Christine Miller was given at the Hotel Pontchartrain on Wednesday evening, March 1, in conjunction with the new Edison Diamond Disc phonograph. Twelve hundred invitations were sent out, and from the tremendous crowd it would seem that everyone re-

ceiving an invitation came and brought their friends. Fully one thousand people were turned away owing to the limited capacity of the hall. Verdi D. Fuller, general superintendent of the Edison phonograph laboratory of Orange, N. J., gave the audience a brief history of the phonograph as it developed to the present time. He introduced Miss Miller, who sang "Abide With Me," the phonograph playing the same song; the audience could not tell the record from the voice of Miss Miller. Arthur Walsh, violinist of the Edison studios, rendered a violin solo simultaneously with its reproduction on the phonograph.

The Gardner-White Co., furniture dealers, Mack and Mt. Elliott avenues, this city, is putting in a full line of Columbia machines and records.

The Brunswick-Balke-Collender Co., of Muskegon, Mich., has received an order for 50,000 cases for phonographs turned out by the Edison Co. The order was placed following a personal visit to the Muskegon factory by H. W. Williams, chief inspector of the Orange works; L. Schall, an expert of the finishing department, and C. W. Leist, another Edison expert.

"What's a Fonola" is the headline which of late has been featured very strongly by the Ling Piano House, 78 Library avenue, both in street cars and newspaper advertisements. The caption was originated by Mr. Ling for the purpose of creating interest. When asked what it means, he replied, "When a better talking machine is made than the Grafonola, my name for it will be the Fonola." There are nine sound-proof demonstration rooms in the Ling Piano House, this department being under the management of Robert Barclay.

C. A. Grinnell, of Grinnell Bros., has purchased property on Lake St. Clair for \$82,000, which he may use as a country home.

The Ecco Talking Machine Co., Detroit, has increased its capital stock from \$6,000 to \$15,000.

Wallace Brown, who conducts an exclusive store for Edison talking machines on East Grand River avenue, recently gave a recital, using Miss Maria Kaiser, lyric soprano, of New York City. Mr. Brown has increased his advertising space in the newspapers and theatre programs, and reports that February was an exceedingly good month.

S. A. Lyndon has opened an exclusive talking machine store in Ann Arbor, Mich.

S. E. Lind, of the local branch of the Columbia Co., is now looking after sales outside of Detroit, in addition to city sales. Manager K. Mills says

A Complete PATHÉ Stock

We have made arrangements to carry a complete stock of Pathephones and Pathé Discs on hand—AT ALL TIMES.

OUR DEALERS will receive machines and records without delay.

We Specialize on Service

PATHÉ DEALERS tell us that their Sales are steadily increasing. We are ready to give our patrons real service to help them get their share of this vast Pathé business.

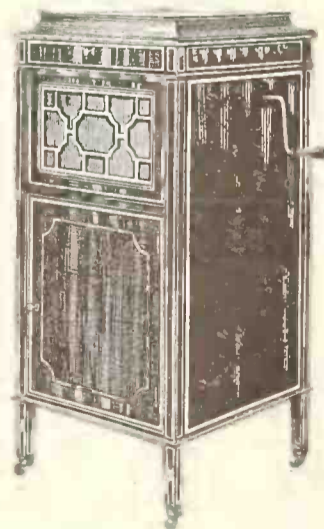

Pathéphonograph Model de Luxe.

WRITE FOR PARTICULARS

Pathephone Co. of Detroit

Pathé Distributors for Michigan

114 FARMER STREET, DETROIT



REPAIRS

All Makes of Talking Machines
Repaired Promptly and Efficiently

TALKING MACHINE REPAIR
AND SALES CORPORATION

ANDREW H. DODIN, President

25 East 14th Street

New York

TELEPHONE, STUYVESANT 292

February was the best month the branch ever had—showing an enormous increase over the same month a year ago. Mr. Mills is exceedingly optimistic about the future of the talking machine business. He anticipates wonderful improvements and results during the next five years.

E. K. Andrew, of the J. L. Hudson talking machine department, is now secretary of the Detroit Talking Machine Association, Sydney J. Guest taking his position as treasurer. The Hudson store has been running a series of artistic advertisements on "Victrolas" that have won high praise.

FERRARI-FONTANA AT THE FRONT.

Antonio Ferrari-Fontana, of the Boston Opera Co., and one of the Edison staff of recording artists, was recently called back to Italy to join his colors, as he is a captain in the Italian army. The command of his government was final, and Ferrari-Fontana was soon at the front, where he was placed in the peculiar position of fighting directly against relatives of his wife, Marguerete Matzenauer, also an Edison artist.

Balance Sound Boxes



No. 1
Retail Prices
Nickel Plate \$3.00
24k Gold Plate \$3.50

Half Size No. 1



No. 2
Retail Prices
Nickel Plate \$3.50
24k Gold Plate \$4.00

Half Size No. 2

Both these Sound Boxes have the "metalloy" diaphragm for sweet and mellow reproduction in the home. Will be furnished with black mica diaphragms at the same price for those wishing greater volume of tone.

Edison dealers may obtain their supply from the Edison Jobber in their zone.

Makers of Phonographs are requested to communicate with the manufacturers

A. F. Meisselbach & Bro.
Newark New Jersey

Makers of High Grade Tone Arms and Sound Boxes, etc., for Phonograph Manufacturers.

We do not make Phonograph parts for cheap machines

LARGER QUARTERS FOR BADGER CO.

Prominent Victor Distributer of Milwaukee Arranges for More Commodious Store for Its Retail Business—Business Unusually Active.

(Special to The Talking Machine World.)

MILWAUKEE, Wis., March 8.—The Badger Talking Machine Co., jobber for the Victor goods in Milwaukee and Wisconsin, has just closed a lease at 425 Grand avenue for new and larger quarters for its retail store, now located at 312 Grand avenue. The new establishment, which will be one of the largest exclusive retail Victrola stores in the country, will be ready for occupancy by May 1. Two floors will be available, and between 6,000 and 10,000 square feet of floor space will be utilized. While only preliminary plans have been made, Harry A. Goldsmith, secretary-treasurer of the Badger concern, says that there will be eleven sound-proof booths arranged on the first floor, while on the second floor there will be a large concert hall and five additional booths. The location is in the heart of the Milwaukee retail district, and the Badger concern ought to meet with a most successful business. R. H. Zinke is manager of the company's retail store.

That the retail talking machine business in Milwaukee during the month of February was the heaviest of any previous month, with the exception of last December, in the history of the local trade, is the assertion of Harry A. Goldsmith, secretary-treasurer of the Badger Talking Machine Co. The situation thus far in March has been unusually satisfactory, he says.

George F. Ruez, president of the Badger Talking Machine Co., accompanied by his wife, recently enjoyed a trip through the Southwest. S. W. Goldsmith, vice-president of the Badger concern, is back from a trip through the Southwest, where he visited his friends in the trade at Omaha, Kansas City and other points and endeavored to round up a few extra machines for the Wisconsin trade. Ettore Barili, traveling representative of the Victor Talking Machine Co. in Wisconsin territory, is visiting the Victor factory at Camden, N. J.

TWO NEW PATHE JOBBERS.

L. F. Blackly, of San Francisco, and A. Victor & Co., Buffalo, Will Give the Pathé Products Aggressive Exploitation in These Directions.

The Pathé Frères Phonograph Co., New York, closed two deals this week whereby Louis S. Blackly, 322 Post street, San Francisco, Cal., and A. Victor & Co., Main and Genesee streets, Buffalo, N. Y., will handle the complete Pathé line as distributors. These two new Pathé jobbers are already making arrangements to give the Pathé products aggressive exploitation, and Mr. Blackly has drawn plans for a Pathé shop which will be one of the most artistic talking machine establishments in the "Golden Gate City."

In a chat with The World, H. N. McMenimen, managing director of the Pathé Frères Phonograph Co., commented upon the splendid start of the new year, January and February sales having been far in excess of all expectations. All models of Pathéphones are meeting with a steady sale, and the new Pathé disc records have been praised by Pathé dealers everywhere.

LAWMAKERS TO VISIT VICTOR CO.

Both Houses of the Legislature Accept Invitation to Inspect the Victor Plant.

(Special to The Talking Machine World.)

TRENTON, N. J., March 10.—Both branches of the State Legislature have accepted invitations recently sent to them to inspect the plant of the Victor Talking Machine Co. in Camden. The lawmakers will be shown through every part of the enormous factory and will be entertained at luncheon by the officers of the company. Each House appointed a committee to arrange as to the date and other plans, the Senate committee being composed of Senators Rathbun, Edge and Ackerson, and Assemblymen Wolverson, Whitman and Kuhlke were appointed to arrange matters for the Assembly.



No. 403 (Vertical Interior)
For New Victrola IX, only.

Height 34½ in. Width 19¼ in. Depth 22¾ in. Holds 224 Victor records.

Mahogany. Quartered Oak.
Average weight crated, 85 pounds.
(If horizontal shelving is desired, order No. 1403.)
(When felt interior is desired, ask for No. 403F.)

IMPORTANT NOTICE

Cabinet 403 is arranged with a rim, which is hinged at the back. This back piece drops down and enables you to slide the new style Victrola IX in. It works very easily and makes a splendid outfit. Nothing to get out of order, and you can put the machine in almost as quick as you could set it on a cabinet without rim.

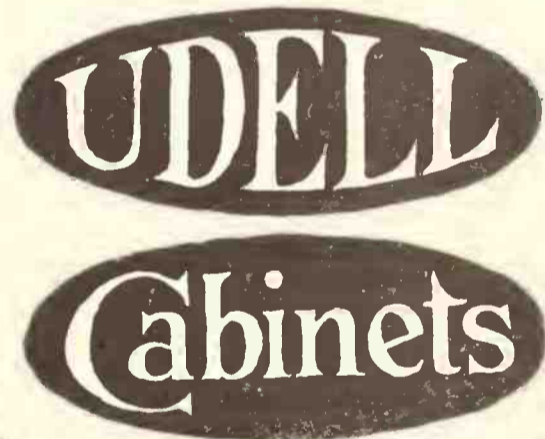

Millions of records are made every year to be stored—where? Why don't you put special emphasis upon the selling of Udell Record Cabinets, for a big, profitable market creates itself EVERY YEAR.

Good cabinets give proper profits, to say nothing of satisfactory service. We've been making cabinets since the talking machine record was a curiosity, so you can depend upon the fact that Udell cabinets are BUILT RIGHT.

A complete line of cabinets—for records, player rolls and sheet music.

Post a postal to-day for catalog.

The Udell Works

1205 West 28th Street

Indianapolis, Ind.



Every time you sell an electric Columbia Grafonola to a customer you have made a beautiful profit—you have made a certain and regular record buyer—and you have added one more completely pleased and actively interested customer.



(Write for "Music Money," a book "full of meat" for those dealers interested in quick and frequent turnover of capital.)

Columbia Graphophone Company
Woolworth Building, New York

W. E. KIPP DINES EDISON DEALERS.

Head of Kipp Phonograph Co., Indianapolis. Returns from Jobbers' Convention Full of Enthusiasm Regarding the Edison Product and Its Possibilities and Spreads Some of It—Company Moves to New Quarters.

(Special to The Talking Machine World.)

INDIANAPOLIS, IND., March 6.—Walter E. Kipp, president of the Kipp Phonograph Co., Edison jobber, returned from a visit to the Edison factory so full of enthusiasm for the Edison machine that he corralled all of his company's Indianapolis dealers and salesmen at a dinner at the German House last night to give them, besides something good to eat, some of his enthusiasm.

After Mr. Kipp had told of his experiences at the Edison factory and had predicted greater Edison triumphs in the improvement of the talking machine. Mr. Kipp got down to brass tacks and sailed into questions concerning local trade conditions, which he said he thought should be improved. Mr. Kipp urged all the dealers and salesmen to work in a spirit of co-operation and to cut out all "mud-slinging" tactics.

A boost for the other fellow, instead of a knock, was Mr. Kipp's idea of how to create better business. He said he desired to see all the dealers in brisk competition, but that he also desired to see only clean-cut methods used.

Every man at the dinner was requested to stand up and introduce himself. By the time the dinner ended, about midnight, everybody was convinced that Mr. Kipp had gained one of his ends at the dinner, namely, that a better feeling of good fellowship had been established among the men who put the Edison machines in the hands of the users.

John Pearson, president of the Pearson Piano Co., and S. Cunningham, of the Pearson Co., were among the other speakers who gave excellent speeches and were able to give the men some valuable pointers.

Among those present were: J. L. Jaxon, S. Cunningham, John S. Pearson, Fred Cunningham, C. E. Stout, F. J. Wilking, E. W. Stockdale, H. E.

Whitman, R. L. Burtsch, J. C. Prince, G. E. Lyons, S. Jasper and T. H. McVhetters, all of the Pearson Piano Co.; Frank J. Carlin, F. S. Lyons and W. P. Trees, all of the Carlin Music Co.; W. W. Wolf, of the William H. Block Department Store; L. W. Minx and J. N. Hayes, of the E. L. Lennox Piano Co.; Arch Olds, J. T. McDermott, R. A. Izor, George W. Kadel, L. T. Carlin and A. H. Snyder, all of the Edison Shop, and Walter E. Kipp and J. Cartmill, of the Kipp Phonograph Co.

Mr. Kipp said that he intended to have another such meeting within the next few months. He said he expected to make the meetings regular and permanent. This is the first time such a meeting has been held for the Indianapolis men, although the company has held meetings for out-of-town dealers.

The Kipp Phonograph Co. recently moved from its quarters in Massachusetts avenue to 325 North Delaware street, where it occupies a modern three-story building with a floor space of 10,000 square feet. Incidentally, the name of the company has been changed from the Kipp-Link Phonograph Co. to the Kipp Phonograph Co. This action was taken at a recent meeting of the stockholders. E. A.

Link, whose name was part of the former name of the company, has not been connected with the company for several years.

The new quarters of the company will enable it to handle its stock much more conveniently, as the old quarters were so small for the business that storage space had to be maintained elsewhere.

BRISTOL & BARBER HAVE THE PATHE.

New York House Added to Important Pathé Distributers in the East.

J. F. Collins, sales manager of the Pathé Frères Phonograph Co., New York, announced recently the consummation of arrangements whereby Bristol & Barber, 115 East Fourteenth street, New York, will be numbered among the Pathé distributers in the East.

Bristol & Barber are prominent in both the piano and talking machine fields and enjoy the confidence of all the dealers with whom they have transacted business in the past years. The firm is enthusiastic regarding the prospects for Pathé business and intends to give this line aggressive exploitation.



THE PREMIER CABINET CO.
Makers and Distributors of the
Premier
TALKING MACHINES and CABINETS

CHICAGO, ILL. WILLIAMSPORT, PA. GOSHEN, IND.

Williamsport, Pa.

John M. Dean CORPORATION
PUTNAM, CONN.

A quality needle with a quantity production is the ideal combination for good needles at the right prices.

Manufacturers of
TALKING MACHINE NEEDLES



SOSS
INVISIBLE HINGES

BRANCH OFFICES:

Chicago
160 No. Fifth Ave.

San Francisco
164 Hansford Bldg.

Los Angeles
224 Central Bldg.

Minneapolis
3416 Second Ave., So.

Detroit
David Whitney Bldg.

"Out of sight, ever in mind"

When you fail to see an unsightly hinge protruding you know "Soss" is the answer. Soss Hinges emphasize beautiful wood finishes as there is no projecting metal on either side of the door. Made in numerous sizes.

Illustrated Catalog S mailed on request.

Write For Further Information

SOSS MANUFACTURING CO.
435-443 ATLANTIC AVE. BROOKLYN, N.Y.



TONE ARMS TURNTABLES

For many years we have been the only manufacturers of good metal phonograph horns, and recently we have added equipment for making Tone Arms and Turntables of highest quality.

These products are made to your specifications only. Ask for estimates.

Phonograph H O R N S **Standard Metal Mfg. Co.**
227 CHESTNUT STREET NEWARK, N. J.

CHANGES IN WINNIPEG TRADE.

Andrew Farquharson Takes Charge of Victrola Department of J. J. H. McLean Co.—Talking Machine Men Don Khaki—Electric Machines Popular—General News of Interest.

(Special to The Talking Machine World.)

WINNIPEG, CAN., March 4.—Andrew Farquharson has taken over the charge of the Victrola department of the J. J. H. McLean Co., succeeding Mr. Robinson, who has gone East.

J. B. Cuthbert, of the Grafonola department of the Winnipeg Piano Co., has enlisted for overseas service with the band of the Ninetieth Battalion.

The local talking machine trade now has in its membership two A. G. Farquharsons, neither of them being in any way related to each other. They are Alfred G. Farquharson, manager of the Western Gramophone Co., and Andrew G. Farquharson, in charge of the J. J. H. McLean Co.'s Victrola department.

L. Burke, until recently with the Frank Morris Columbia department, has resigned and is now in charge of the J. A. Banfield Columbia business.

Mrs. Field, an accomplished pianist, is now in charge of the Frank Morris Columbia department.

E. Clegg, who has been connected with Babson Bros., Edison distributors, for some time as shipper, has donned the khaki. H. Stevenson, at one time connected with the Doherty Piano Co. as salesman, is now in charge of the retail department of Babson Bros., succeeding Mr. Gillenan, who has taken charge of the mail order department of that house.

Goulding Bros. & Skinner's Victrola business indicates that the electrically driven machine appeals to the public. Three were sold recently.

Walter Belknap and Miss Robinson, who were both connected with the Doherty Piano Co. some time ago, are now in charge of the Columbia department of Stanwood's, Ltd.

T. Nash, manager of His Master's Voice Gramophone Co., Toronto, visited the local distributing house of Victor lines to see the latter comfortably installed in its new warehouse at 122 and 124 Lombard street.

The Western Gramophone Co., of which firm A. G. Farquharson is the manager, has improved and enlarged its storage and shipping facilities by removing to 122 and 124 Lombard street. The new headquarters are roomy and well lighted. In each of the windows facing on Lombard street are displayed attractive "His Master's Voice" signs. Two showrooms adjoin the office, to the rear of which are the stock and shipping departments.

Christine Miller, who makes Re-Creations for the Edison Diamond Disc, recently had the unique experience of singing for Miss Helen Keller at the home of Mrs. William Thaw in Pittsburgh. As Miss Miller sang Miss Keller lightly placed the fingers of one hand over Miss Miller's lips and rested the other hand on the piano. Miss Keller seemed delighted with what she heard through her fingers.

WE MAKE

Tone Arms and Sound Boxes

For all makes of Talking Machines

ALSO

Attachments for Victor, Pathé, Edison and Columbia Machines

Let us tell you about them before placing your orders

THE UNION SPECIALTY AND PLATING COMPANY

SPECIALISTS IN PHONOGRAPH PARTS

409 Prospect Avenue, N. W.

CLEVELAND, O.

BELIEVES IN PREPAREDNESS.

A Sonora Dealer in New York City Places an Order for 600 Machines for Immediate Delivery, of the Retail Value of Nearly \$60,000—Does Not Intend to Be Caught When the Demand for Talking Machines Is Active.

As an illustration of the popularity of the Sonora phonograph in New York City alone, one of the dealers of the Sonora Phonograph Corp., who occupies ordinary quarters in the city and has only one store, placed his order for 600 machines of mostly large size for practically immediate delivery, the order amounting to nearly \$60,000 retail value. This dealer is one of the great many who could not foresee the tremendous demand and popularity of the Sonora last year, and as a consequence was caught with an inadequate supply. He does not intend to be caught in the same position again, and has therefore placed his order for delivery as soon as possible of the styles that are enumerated below. "This is a policy that would be well for other Sonora dealers to follow," added Joseph Wolff, secretary, "as there is no indication that the popularity of the Sonora is going to diminish, but, on the contrary, will greatly increase during the present year."

Below is a copy of the order, which totals almost \$60,000:

50 Monarchs.	at \$35.00	\$1,750
50 Excelsior,	" 50.00	2,500
180 Troubadours	" 75.00	13,500
100 Imperial,	" 100.00	10,000

112 Baby Grands at \$135.00	\$15,120
90 Elites,	" 150.00	13,500
10 Grands,	" 225.00	2,250
2 Invincibles,	" 300.00	600

Total\$59,220

As a number of the models are wanted in special woods, for which additional charges of anywhere from \$25 to \$75 per machine are made, this order totals considerably over the \$60,000.

POSES AS COLLECTOR FOR ROTH.

Bogus Collector Tried to Secure Payments on Victrolas in West New York.

A young man, fraudulently representing himself as a collector for B. H. Roth, Victor dealer at 581 Bergenline avenue, West New York, N. J., recently attempted to collect instalments on machines which had been sold by the Roth store. He made the error of calling at a home where the customer had purchased a Victrola for cash. The customer notified the store, and the police were given a description of the fraud by Mr. Roth. He is about twenty-eight years of age, dark hair and eyes, and wore a dark suit and overcoat and a soft, black felt hat. He is a fluent and pleasant conversationalist, is smooth shaven, and knows something about the talking machine business technically.

Marie Rappold, who makes Re-Creations for the Edison Diamond Disc, recently brought herself fresh laurels in the character of Freia in "Das Rheingold."

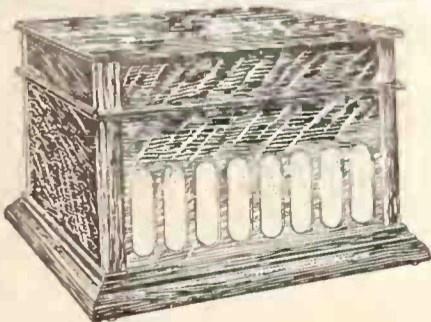

\$15.00

to

\$200.00

Rich Cabinet Work, Built To Suit the Most Fastidious

"THE CRESCENT"

All Talking Machines in One

The Only Complete Universal Line That Will Play All Records of Any Make

Write for Terms and Territory Today

Crescent Sales Company

Distributing Agents

PROVIDENCE

RHODE ISLAND

35c.

is the Price of the most popular Double-faced Record on the Market.

"The Crescent"

plays longer than any 75c. Record.

24 New Selections Just Out



**If, by any chance, you haven't heard the
Columbia Double-Disc Records by the
Taylor Trio, you've missed something.**



*(Write for "Music Money," a book "full of meat" for those
dealers interested in quick and frequent turnover of capital.)*

**Columbia Graphophone Company
Woolworth Building, New York**

ELECTRIC MACHINES POPULAR IN KANSAS CITY.

New Models Proving Quite a Feature with the Various Stores—Shortage in the Higher Priced Machines—Peck Service Department Pays—John F. Ditzell an Athlete—Managers Visit the East—Dealers' Week at Edison Shop—General News of Month.

(Special to The Talking Machine World.)

KANSAS CITY, Mo., March 6.—All Kansas City talking machine men are very enthusiastic regarding conditions in their line. Reports are to the effect that business is great and prospects are greater. The sale of the electric machine is getting to be quite an item in all the stores, and most of the heads of the departments are making special efforts to push these machines. Records also are having an unprecedented year, and it is a well-known fact that several stores have been sold out of certain numbers before being able to get another supply from the head office. More space to the departments, additional sales force and more extensive advertising are a few of the results arising from the excessive demand for talking machines in this territory.

Harry B. Bibb, manager of the talking machine department of the Jones Store Co., bemoans the lack of the higher priced machines. Mr. Bibb has had trouble in getting machines of any kind, especially during the first part of the year, but as to the medium priced sellers, that shortage has been decreased. This is not the case, however, according to Mr. Bibb, with the better finished and more expensive models. Oak and similar special woods are hard to get, he says, and this will probably be

the case for some time. The Jones Store reports an excellent trade.

A feature at the George B. Peck dry goods store that is being pushed rapidly is that of the service rendered to purchasers. John F. Ditzell, manager of the talking machine department at that place, during the month of February laid special stress on this fact in the advertising space of the newspapers allotted him. Regarding the usefulness of this enterprise Mr. Ditzell says: "It surely has helped our trade. I know of instances where people have advised their friends to buy here on account of that service." Peck's maintains a force of three men to look after this end of the business.

John F. Ditzell, by the way, is a leading athlete at the Kansas City Athletic Club, where he is known as a handball fiend. Mr. Ditzell has been a member of that organization but three years, and in that time has every year reached the finals in the club championship series. He says that after a little more perfection of his game he is going to challenge the following two gentlemen for the championship of the talking machine trade, the game to be played on their own court: Roy Keith, of the Chicago Talking Machine Co. and W. B. Fulghum, manager of the order department at the Victor factory in Camden.

Warren H. Haile, manager of the retail department at the Schmelzer Arms Co., who recently came here from South Bend, Ind., is very much pleased with conditions in Kansas City.

M. W. Bardwell, of the Pathephone department of the Household Fair, announces that his company will probably handle the motor machines, now that the price is to be reduced. He is very enthusiastic regarding the possibilities, and is expecting to make a great showing when it comes to him.

The Jenkins Music Co. is enlarging its talking machine space, remodeling the first floor of its establishment so as to add six new record rooms, making a total of fifteen. The machine sales department will continue to be on the third floor and the record rooms all on the first.

E. A. McMurry, Kansas City manager of the Columbia Graphophone Co., who has been in the East for the past ten days, reports conditions as very excellent. Mr. McMurry went on a business trip, mainly in an effort to get goods to fill orders, and visited New York City, Boston, Bridgeport, Pittsburgh and other places in the East.

C. T. Cunningham, traveler for the Edison Co. out of Kansas City, was in the office recently, and remarked on the excellent condition and prospects in his territory, northern Kansas.

Two managers of Kansas City talking machine houses have recently returned from Eastern trips, they being A. A. Trostler, of the Schmelzer Arms Co., who was in New York attending a meeting of the executive committee of the National Association of Talking Machine Jobbers, and M. M. Blackman, Kansas City manager of the Edison Shop, who was a visitor at the Edison factory.

M. M. Blackman, manager of the Edison Shop, announces that beginning Tuesday evening, March 7, his store would start a series of nine evening concerts, with Heinrich Rittmeister, concert master of the Kansas City Symphony Orchestra, as assisting artist. Admission to these concerts will be by invitation only, of which the greater portion will go to machine owners. The concerts will be held at the Edison parlors.

Dealers' week at the Edison Shop in Kansas City was very much of a success, over thirty out-of-town dealers coming from all parts of Arkansas, Missouri and Kansas. Some of those present during this special period are as follows: H. L. Paden, Sr., Atwood, Kan.; H. B. Wiley, Sr., Nevada, Mo.; H. F. Baier, Salina, Kan.; C. L. Smith, Columbus, Kan.; A. E. Luster, Fort Smith, Ark.; E. D. Lape, Coffeyville, Kan.; Hans Peterson, Sylvan Grove, Kan.; Homer Bashore, Sapulpa, Okla.; A. Seifert, Clyde, Kan.; Carl Latenser, Atchison, Kan.; A. A. Proctor, Princeton, Mo.; Mr. and Mrs. J. A. Lampkin, Warrensburg, Mo.; Mr. and Mrs. R. C. Bollinger, Fort Smith, Ark.; I. W. Guisinger, Fayetteville, Ark.; W. R. Lighton ("Billy Fortune"), Fayetteville, Ark.; George A. Hibbard, Medicine Lodge, Ark.; A. K. Snyder, Winfield, Kan.; W. H. Felson, Liberty, Mo.; H. B. Wiley, Jr., Nevada, Mo.; James E. Thornton, Hamilton, Mo.; Fred Jackson, Atchison, Kan.; Miss Jean McDougal, Sedalia, Mo.; Runenberger Bros., Harrisonville, Mo.; L. W. Cahill, of Cahill Bros., Windsor, Mo., and Burke Bros., Columbus, Scammon and West Mineral, Kan.

Have you ever tried the

ANDREWS SERVICE

for Victrolas and Victor records
or Edison Cylinder goods?

THERE IS NONE BETTER

When you think of Talking Machines, think of

W. D. ANDREWS, Buffalo, N. Y.

NEW EDISON SALON IN MONTREAL.

Handsome Quarters for the Display of Edison Phonographs Opened in Department Store of Goodwins, Ltd.—Victrola Music Heard Over Transcontinental Telephone—General Business Conditions Most Satisfactory.

(Special to The Talking Machine World.)

MONTREAL, CAN., March 4.—Goodwins, Ltd., one of Montreal's leading department stores, celebrated the birthday of Thomas A. Edison by opening its new Edison salon, where it has five sound-proof booths at the disposal of customers. The opening day saw the disposal of a Model A 100, valued at \$137.50, to a prominent local citizen, besides a large number of records. The Edison salon has been placed in charge of phonograph experts from the Edison laboratory, including L. Bourgett and C. R. Woods, assisted by Miss Forest, an experienced talking machine saleslady. Goodwins, Ltd., is using forceful "copy" in the leading French and English daily newspapers directing attention to the fact that it is now handling Edison Diamond Disc machines. Manager Coleman, of the Montreal branch of R. S. Williams & Sons, Ltd., Edison jobbers in the province of Quebec, was instrumental in closing this deal.

Mr. Edison's birthday was celebrated in Canada by the majority of Edison dealers in various ways, mostly by advertising and holding recitals.

At the invitation of the Bell Telephone Co. of Canada, Ltd., Montreal, a select assembly of prominent business men recently met at the Ritz-Carlton Hotel to hear the most wonderful demonstration ever witnessed in Montreal. It constituted the opening of the long-distance telephone across the Dominion of Canada from Montreal to Vancouver, a distance of 4,227 miles, in which Victrolas and Victor records played a most prominent part.

The most dramatic moment of the whole evening was when, after all had talked with Vancouver, the line was switched, and San Francisco was attached to the other end. As distinct as any message sent in this city, the operator's voice as each exchange was passed through answered. Mr. Heller was at the San Francisco end and played records, which were heard as plain as if they were in your own room, ending with the English national anthem.

A heavy demand is still noticeable for A5756, 'Cello Interpretations of Pablo Casals, which were featured in the February list of Columbia recordings.

C. W. Lindsay, Ltd., through the able efforts of Manager Norman F. Rowell, has succeeded in doubling its Victrola business every month since September to date, with the exception of December.

Miss G. Vezina, in charge of the talking machine department of Almy's, Ltd., reports the consummation of some nice business this month to date, including several disposals of various models of Columbias. The concern's Saturday afternoon and evening recitals are being well attended.

Rough Sapphires

for manufacturers of
Needles, Reproducers and Talking Machines

HENRY E. OPPENHEIMER & CO. 1 MAIDEN LANE
NEW YORK CITY

The Canadian Graphophone Co., Columbia jobber in the province of Quebec, is well satisfied with trade so far this year (which, by the way, shows a large increase over the corresponding period a year ago). It is not only holding its old accounts but is daily adding new ones.

Recent Sonora agencies placed in Montreal are the following: Charles Culross, J. A. Hurteau & Co., Ltd.; N. G. Valiquette, Ltd.; H. P. Labelle & Co., Ltd., and Ed. Archambault.

Harry Lauder's recent appearance in Montreal showed that he was still as great a favorite as ever, and the Berliner Gramophone Co., Ltd., reports a big business in all its stores for his old and new records.

H. P. Labelle & Cie, Ltd., 147 St. Catherine street, has taken on the representation of the Columbia in addition to the Sonora.

Arthur Blouin, Sherbrooke, Que., is handling a large number of Columbia Grafonolas.

Ed. Archambault is installing a number of sound-proof booths. He features Edison, Sonora and Columbia products.

Layton Bros. have under consideration alterations and additions which will give them still greater facilities for handling an increasing business in Edison and Columbia machines.

THOS. QUINLAN BECOMES MANAGER

Of the Concert and Operatic Department of the Columbia Graphophone Co. with Headquarters at the Recording Laboratory.

The Columbia Graphophone Co., New York, has announced the appointment of Thomas Quinlan as manager of the company's concert and operatic department, with headquarters at the recording laboratory, 102 West Thirty-eighth street, New York. Mr. Quinlan assumed his new duties the first of the month, and has already given unmistakable evidences of his remarkable skill and ability.

Mr. Quinlan is prominent in musical circles both here and abroad, and particularly in Europe, where he achieved unlimited success as an operatic impresario. Mr. Quinlan was the "man behind" the Quinlan Grand Opera Co., which organization established the reputation of being a household word throughout Great Britain, South Africa, Australia, New Zealand and the Dominion of Canada. Mr. Quinlan conducted this company twice around the world, traveling 150,000 miles in all. The repertoire of the company consisted of

forty operas, and these operas were staged from the largest equipment ever carried by one company. The company's success was tremendous and performances were given before crowded houses in all parts of the world. Mr. Quinlan



Thomas Quinlan.

was also associated with other important musical enterprises in England which achieved renown.

Mr. Quinlan has the personal friendship of all the leading artists in operatic and concert circles, and in his new position with the Columbia Co. he will be able to utilize the same measures of aggressiveness and far-sightedness which contributed so materially to his success abroad.

BOOKED SOME BIG ORDERS.

Philip A. Ravis, vice-president of the New York Album & Card Co., New York, N. Y., manufacturer of Nyacco metal-back albums, returned last week from an extended Western trip. Mr. Ravis secured a good-sized list of orders and states that the dealers are optimistic to an unusual degree. He was impressed with the fact that the trade as a whole is demanding an album of better quality than the average album of several years ago, and states that the dealers are not paying any attention to albums which do not give adequate service to their patrons.

ESTABLISHED 1868

EDWARD B. JORDAN & CO., Inc.

127-135 DEGRAW ST.—36-60 TIFFANY PL., BROOKLYN, N. Y.

Talking Machine Cabinet Manufacturers

We made the first talking machine cabinets created in this country, and we have specialized in this particular line ever since.

We will submit special designs of talking machine or record cabinets, or quote you from blue prints or samples. We manufacture to order only.



Each buyer and each seller of a Columbia \$50 Grafonola is always satisfied—the one with the quality, the other with the profit.



(Write for "Music Money," a book "full of meat" for those dealers interested in quick and frequent turnover of capital.)

Columbia Graphophone Company
Woolworth Building, New York

TALKING MACHINE MEN MEET.

Advocate Passage of Stevens Bill, Appoint New Committees and Listen to Address on Motor Troubles at Interesting Session.

On Wednesday, February 23, a meeting of the Talking Machine Men, Inc., was held in the assembly room of the Merchants' Association, Woolworth Building, New York, with President John A. Hunt presiding. The usual "spirit of action" on the part of those present caused a lively, snappy session.

A petition advocating the Stevens Bill was signed by all. Reports were then made and accepted from the several committee and new men were appointed to serve on the committee on credentials, the committee on membership and the committee on advertising. The latter is a new

committee, the function of which is to acquaint the association members with the advertising rates of all the newspapers in and around New York City, with such recommendations as may prove fitting.

Interesting floor discussions followed concerning the matter of the dealer insuring a machine sold on instalments and on the question of extending the organization's roll of members. The president announced that he will devote considerable time during the next month to motoring around New York and neighboring cities in a "pep" movement to increase the members.

A. H. Dodin, president of the Talking Machine Repair and Sales Co. and specialist on the repair of talking machines, talked on the elimination of motor chugging. He will give additional talks of a technical nature at the meetings which are to follow.

In the election proceedings Herman J. Jaffee, of Hoboken, was made vice-president for the State of New Jersey, A. J. Beers was elected as a new member, and the Hotel McAlpin was designated as the place for the next annual banquet in April.

COLUMBIA DEPARTMENT IN DALLAS.

(Special to The Talking Machine World.)

DALLAS, TEX., March 6.—The Will A. Watkin Co., one of the pioneers among the music houses in Texas, recently held the formal opening of its Columbia Grafonola department, where a full line of machines and records is shown and demonstrated under most favorable conditions. The company issued a special folder to mark this important event.

ISSUE ATTRACTIVE DISPLAY CARD.

The Wonder Talking Machine Co., New York, manufacturer of "Wonder" talking machines, has advised its dealers that it now has ready for distribution a very attractive display card, which is also suitable for use as a mailing card to the dealers' prospects. Those dealers who have taken advantage of the company's offer to mail the cards to prospective purchasers are enthusiastic over the results achieved.

OPERATED ON FOR APPENDICITIS.

Harry L. Marshall, Pacific Coast supervisor for Thomas A. Edison, Inc., was operated on at St. Joseph's Hospital, Denver, recently, for appendicitis. As soon as the news of the success of the operation reached the Orange laboratories, Thomas A. Edison, Inc., sent him the following wire:

"We all hope your recovery may be rapid and complete, but you must not run unnecessary risk by leaving the hospital too soon. A few days may make a big difference in your condition but none in your territory. Good luck."

W. C. Wyatt, of the Denver Dry Goods Co., Edison jobber at Denver, did everything possible to make Mr. Marshall comfortable.

The Jewelry Sales Co., of Marshalltown, Ia., has opened a store for the sale of pianos and talking machines at Main and First avenues.

PATHE SECURES FAMOUS SOPRANO.

Eleonora de Cisneros, Grand Opera Star, Signs Contract to Make Records for the Pathé Phonograph Exclusively from Now on.

H. N. McMenimen, managing director of the Pathé Frères Phonograph Co., New York, announced this week that arrangements had been completed whereby Mme. Eleonora de Cisneros, the famous operatic mezzo-soprano, will record exclusively for the Pathé disc library in the future.



Mme. Eleonora de Cisneros.

Mme. de Cisneros is well known to music lovers both here and abroad, having appeared with some of the leading opera companies in this country and in Europe. She played important roles for the Metropolitan Opera Co., Manhattan Opera Co. and Philadelphia-Chicago Opera Co., and has also appeared in numerous concerts and recitals. Her performances have won hearty praise from the critics, and Pathé dealers will doubtless find a ready sale for her records.

Albert Spalding, exclusive Edison Diamond Disc artist, played his way to the hearts of Boston recently at a concert at Jordan Hall in the Hub City. H. T. Parker, music critic of the Boston Transcript, paid Spalding a most remarkable tribute.

UKULELES

The highest sellers in the small musical instrument business. Why handle inferior machine-made American imitations when you can get at similar prices the genuine hand-made instruments of

Jonah Kumulae, Honolulu

The old, thoroughly seasoned native Hawaiian Koa of which they are constructed is greatly superior to any other wood in tone quality—Kumulae instruments have no superior in this respect.

Send for wholesale price list.

SHERMAN, CLAY & CO.

163 Kearny Street San Francisco
Sole Distributors for the United States and Canada

TRANSFER NAME PLATES for TALKING MACHINES

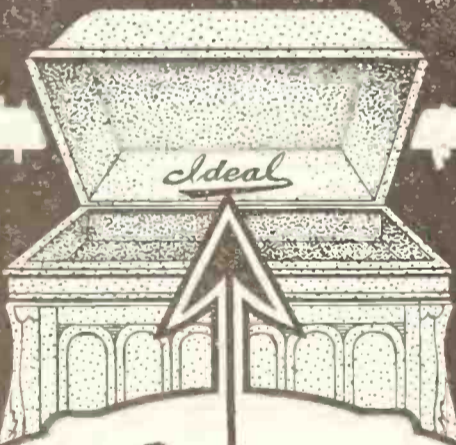

Ideal
PERFECT TONE

Dealers Derive Prestige by applying Transfer Nameplates on Talking Machines.

Like the manufacturer, the most conspicuous place can be used for your nameplate. Refinement and Beauty are embodied in these original Designs—they are Artistic and Ornamental. Easily applied.

Send copy for FREE Sketch, sample and quotations.



GLOBE DECALCOMANIE CO.
JERSEY CITY, N. J.

NEW EDISON SHOP IN AUSTIN, MINN.

Handsome Quarters for the Display and Sale of Phonographs Opened Recently by the Schleuder Paper Co. in That City.

(Special to The Talking Machine World.)

AUSTIN, MINN., February 29.—The Edison Shop, at 124 West Bridge street, conducted by the Schleuder Paper Co., of this city, which was formally opened to the public recently, continues to be the source of interest to many visitors because of its attractive arrangement. Its completeness emphasizes the enterprise of this company as well as the fact that it is a live Edison dealer and sees a great future in the Edison disc line.

One of the striking features of this building is the concert hall, which seats from seventy-five to one hundred people. The color scheme is ivory white and silver gray, with side wall panels containing beautiful water-color mural paintings. A stage runs across one end of the hall and is twenty-three feet wide by twenty-four feet long.

Leading from the concert hall is a handsomely



Stage of the Concert Hall.

decorated lobby, twenty feet long, and lined with demonstration booths, each one of them being decorated and furnished in a different color scheme. A large stockroom also opens off the lobby and is convenient for the salesmen.

Throughout the building, and particularly in the



View Through the Lobby.

concert hall and booths, special attention has been given to the question of ventilation. The elaborate lighting system includes fixtures silver-plated in a dull silver finish, and all the general hardware in the building is in the same finish to match.

Both before and since the holidays there have been daily concerts given afternoon and evening in the concert hall, which have produced excellent results in the matter of sales.

A. O. Price, of the Compton-Price Piano Co., Coshocton, O., has completed and is now testing out a talking machine, which he claims is radically different from anything at present on the market.

The Melophone
TALKING MACHINE
C O M P A N Y
40 COOPER SQUARE, NEW YORK

Manufacturers of the
Melophone and Liberty Phonographs
And of
Motors and Parts for the Trade

\$5

**for a LANSING
KHAKI MOVING COVER**

This gives you one of the big Lansing Covers for any of the large cabinet machines. It is made of government khaki and the inside lining is of cotton flannel. Heavy cotton is used for the interlining, there being four thicknesses, these being quilted to keep the Cover of uniform thickness and durability. The Cover is known as Grade B.

Write for this Cover to-day; better make the order read "6" if you do a large business. Anyway, see the value represented in this one, not only as a quality cover, but its saving to you in excess delivery charges.

WRITE FOR BOOKLET

E. H. LANSING

611 Washington St., Boston, Mass.

CHANGES AT COLUMBIA OFFICES.

Advertising Department Occupies Space Formerly Used by Record Department.

In order that the various departments at the executive offices may work under efficient conditions and to allow for the increased requirements of its fast-growing business, the Columbia Co. has made several changes in the lay-out of its executive office floor in the Woolworth Building which have already proven their value. The personal record, professional and international record departments have been removed from the Woolworth Building to the Columbia Co.'s record laboratory at 102 West Thirty-eighth street, New York, where they will be in close proximity to the most important division of the company's work.

The space formerly utilized by these departments has been taken over by the advertising department in its entirety. In its new home the advertising division will have increased space, which it needed badly, and as these offices are in a more secluded section of the floor than the executive offices proper, Advertising Manager Baker and the various members of the department will be able to work in comparative quiet and peace. The offices formerly occupied by the advertising department will be utilized as additional space for the financial and export departments.

D. H. Delzell, president of the Columbia Stores Co., Denver, Col., Columbia distributor, was a visitor to the executive offices recently. Mr. Delzell spoke very optimistically of conditions in Colorado, stating that the Columbia dealers in his territory had closed a record-breaking business and are preparing to do an even greater business in 1916. Mr. Delzell congratulated the company on the splendid quality of the records which are being produced, and was particularly well pleased to learn that the company had arranged to materially increase its production the coming year.

EXPOSITION FOR CAMDEN, N. J.

Victor Talking Machine Co. Actively Interested In Plans for Celebration in May.

The Victor Talking Machine Co., one of the leading if not the leading industry of Camden, N. J., is actively interested in the plans for an Exposition of Industry and Civic Celebration in Camden, to be held from May 18 to 27.

The Pennsylvania Railroad plans to advertise this exposition along its right of way and make special rates to attract people to Camden while it is open.

CADMAN AND THE VICTROLA.

Noted Composer. While in Los Angeles, Listens to One of His Own Records at Barker Bros.

(Special to The Talking Machine World.)

LOS ANGELES, CAL., February 28.—During the visit recently of Charles Wakefield Cadman, the eminent composer, to the talking machine department of Barker Bros., and an interesting souvenir of his visit is the photograph taken of Mr. Cad-



C. W. Cadman Listening to His Compositions. man listening to one of his own compositions being played on a Victrola XVI. Mr. Cadman recently purchased a Victrola XVI from Barker Bros., and is now making his home in Los Angeles. The combined picture of the artist and the instrument will doubtless appeal to many admirers.

The man who pushes the goods the manager wants pushed is the man who is going to find the way to the front easiest.

USE
"Arrow"

**SOUND BOXES
TONE-ARMS
MOTORS**

**ARROW MOTOR CO. 207 Market St.
NEWARK, N. J.**

LATEST PATENTS RELATING TO TALKING MACHINES AND RECORDS

(Special to The Talking Machine World.)

WASHINGTON, D. C., March 8.—SOUND-REPRODUCING MACHINE.—John T. Prout, New York. Patent No. 1,167,838.

The present invention relates more particularly to certain improved attachments for sound-reproducing machines, whereby said machines are rendered of greatly increased efficiency.

According to this invention, after the inauguration of the operation of the machine the tone arm is reset, so that the record in use may start anew. This may be accomplished irrespective of the distance that the stylus has traversed along the effective zone of the disc—that is to say, the record is permitted to be entirely played and then be re-

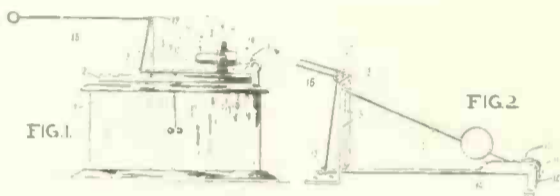

peated or partially played and the stylus returned to any predetermined distance, and that portion already gone over traversed again by the stylus. The mechanism whereby this is accomplished is of extreme simplicity and may be so designed as to be used in conjunction with records of varying diameters.

In the accompanying sheet of drawings, in which like reference characters are employed to designate like parts throughout the respective views, Fig. 1 is a view in side elevation of a sound-reproducing machine embodying the features of the invention. Fig. 2 is a detail perspective view showing the resetting mechanism.

TALKING MACHINE.—Francesco Cirell, Philadelphia, Pa. Patent No. 1,167,796.

This invention relates to improvements in talking machines, the object of the invention being to provide an improved construction of talking machine which may be used in connection with various styles of records, and provide improved means whereby the sound box may be located at either of two positions relatively to the tone arm.

A further object is to provide improved means whereby the tone may be softened or increased as for supporting the stylus at any angle desired, desired.

A further object is to provide an improved construction of sound box having openings therein, and capable of adjustment relatively to the tone arm to position the stylus at the angle desired.

A further object is to provide an improved construction of stylus bar adapted to support a needle at various angles and positions, employing a single set screw to secure the stylus in any of its operating positions.

In the accompanying drawings Fig. 1 is a view in longitudinal section through the improved tone arm. Fig. 2 is a fragmentary view on an enlarged scale partly in plan and partly in section through the free ends of the tone arm. Fig. 3 is a view in section on the line 3—3 of Fig. 2. Fig. 4 is a view in elevation of the outer face of the sound box. Fig. 5 is a similar view of the inner face of the

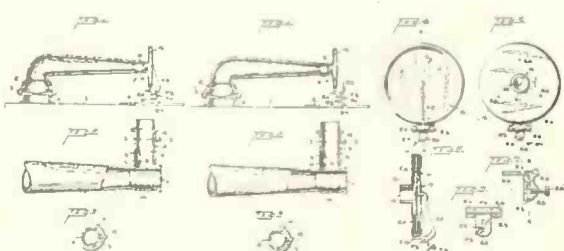

sound box. Fig. 6 is a view in section through the center of the sound box taken on line 6—6 of Fig. 4. Fig. 7 is an enlarged view in section through the lower portion of the stylus bar, and Fig. 8 is a view in section on the line 8—8 of Fig. 7.

PHONOGRAPH.—Newman H. Holland, West Orange, N. J., assignor to the Jersey Patent Co., same place. Patent No. 1,167,500.

This invention relates to phonographs, and more particularly to an improved record support therefor.

Ordinary phonograph records change in diameter to a considerable extent under different temperature conditions, expanding under heat and contracting under cold, whereas the supports upon which the records are mounted change but little in diameter under the same conditions. As these supports are so constructed that when the records are placed thereon a tight engagement will be maintained between the same and the records, it frequently happens that the latter become so tightly locked in place that it is difficult to remove them without damaging the record surface or breaking the records themselves.

The object of this invention is to provide a record support adapted to firmly hold a sound record or a sound record blank and yet to permit its ready removal. In conformity with this object, a support is provided in which the record-engaging means is movable toward and from the axis of the support so that the said means may be firmly held in engagement with the bore of the record or blank or moved inwardly to permit disengagement of the latter.

Figure 1 represents a vertical longitudinal section through the center of the mandrel of a phono-

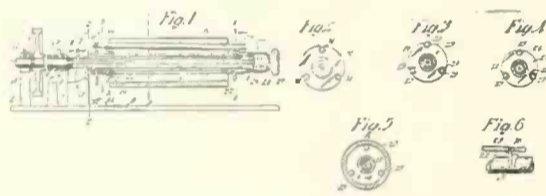

graph embodying the invention, a part of the frame of the phonograph being shown in elevation; FIGS. 2, 3, 4 and 5 represent sections of the mandrel taken on lines 2—2, 3—3, 4—4 and 5—5, respectively, of Fig. 1; Fig. 6 represents a fragmentary section of a modification of one of the details of construction.

PHONOGRAPH REPRODUCER.—Adolph F. Gall, West Orange, N. J., assignor to the New Jersey Patent Co., same place. Patent No. 1,167,489.

This invention relates to phonograph reproducers which are provided with a pair of reproducing styli adapted to track records of different character, as for example, records having 100 and 200 threads per inch respectively, said styli being so mounted that either may, by a simple manipulation, be brought into or out of operative position with respect to the record surface at will. In the invention, the styli are carried by different surfaces of a single stylus lever, the stylus lever being pivotally mounted in such a manner that it may be rotated about an axis substantially parallel with the diaphragm of the reproducer, and substantially parallel to a diametrical plane of the sound record, in which plane is located the sound record groove in which the stylus is adapted to track in order that either stylus may be brought into operative position. Preferably, the styli are carried by the top and bottom surfaces of the stylus lever, that is, 180 degrees apart, the lever being pivoted to a member which is rotatable about an axis extending longitudinally of the lever in lugs depending from the floating weight, the tail of the lever being connected to the diaphragm in such a manner that the diaphragm will not be placed under undue stress during the adjustment of the lever to position the stylus. Preferably, stops are provided to limit the rotation of the lever during adjustment to a swing of 180 degrees, and also, preferably, spring means are provided for holding the stylus lever in either adjusted position.

This invention also comprises an improved indicating means for indicating which stylus is in operative position.

In order that the invention may be more fully understood, reference is hereby made to the accompanying drawings, forming part of this specification, in which—

Figure 1 is a central vertical section of a phonograph reproducer embodying the invention, certain parts being shown in side elevation. Fig. 2 is a bottom plan view of the same. Fig. 3 is a detail end view looking from the right in Fig. 1 showing the means for supporting the floating weight. Fig. 4 is a detail end view looking from the left in Fig. 1 showing one form of indicating device. FIGS. 5 and 6 are detail views showing modified forms of

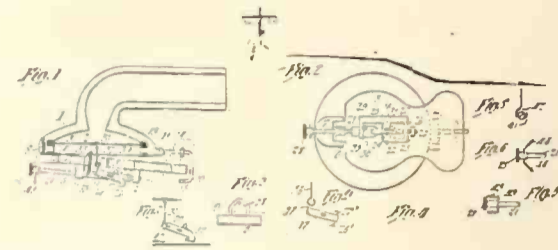

the indicating device. Fig. 7 is a side elevation of the stylus lever showing modified connections to the diaphragm. Fig. 8 is an end view of the same looking from the left in Fig. 7. Fig. 9 is a side elevation of the stylus lever showing a modified form of stylus mounting.

In all of the above figures corresponding parts are denoted by the same reference numerals.

MOLDED ARTICLE.—Jonas W. Aylsworth, East Orange, N. J., assignor to the New Jersey Patent Co., West Orange, N. J. Patent No. 1,167,468.

This invention relates to molded objects, such as sound records, and more particularly to such molded objects as are formed by the method or process described in application, Serial No. 674,289, filed January 30, 1912, of which this application is a division. The said process involves the formation of a surface layer of material upon the smooth polished surface of a metallic plate or other blank mold and the transfer of the same to the surface of the object to be coated under heat and pressure with the firm adhesion or welding of the surface veneer to the object. The surface layer thus formed has a smooth homogeneous surface free from air bubbles, dust particles and the like, and is

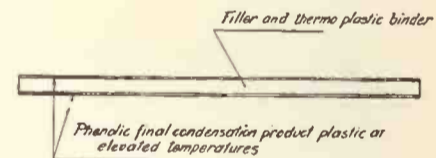

of a material which is hard when cold, but sufficiently plastic when heated, to take a clear impression from a mold or die, such a sound record matrix.

PHONOGRAPH MECHANISM.—William Notter and Richard S. Arthur, New York, assignors to the Talking Doll & Novelty Co., Inc., same place. Patent No. 1,167,842.

This invention comprises certain improvements in phonograph mechanism, having as objects, among others, to effect a material simplification of such mechanisms, to secure compactness in the construction and relation of the elements, to insure strength and rigidity in the structural parts—more especially in apparatus where the mechanism is carried in projecting relation from a support—to enable the apparatus to be quickly and easily assembled and parts to be readily replaced in event of breakage, to render it in a high degree automatic without introducing complications, to facilitate the insertion and removal of records, and to make the apparatus proof against meddling or unskilled manipulation.

The mechanism is more particularly designed for installation in small form in dolls or other toys, clocks, etc., as illustrated for example in Fig. 1 of the accompanying drawings, its compact and sturdy construction, its ability to perform equally well in any position, and the simplicity of its operation especially fitting it for such uses. The apparatus may be made on a larger scale, and part or all of its features may be applied in numerous specifically different ways, for example, in the production of so-called hornless or cabinet machines of small size.

A feature of the mechanism which contributes to the flexibility of external design as well as to the securing of desirable acoustic effects, consists in the possibility of disposing the reproducer at any

LATEST PATENTS RELATING TO TALKING MACHINES—(Continued from page 82).

or various points around the record drum, together with the consequent freedom in the matter of the disposition of the sound conveyor or amplifier. In the particular instance herein shown the reproducer is located below the record drum, while the sound

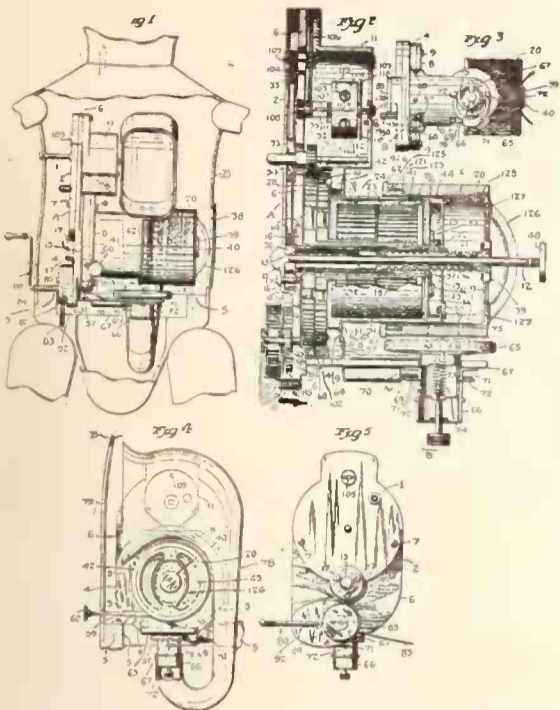

conveyor extends around and above the same, though it will be understood that this orientation is not necessarily fixed, since in the case of a talking doll, for example, the mechanism as a whole may be disposed in any position according to the manner in which the doll is held.

In the accompanying drawings illustrating the invention by means of the embodiment at present believed to be preferable for use in dolls, Fig. 1 is a front elevation of the mechanism in the body of a doll, the doll body being partially sectioned and

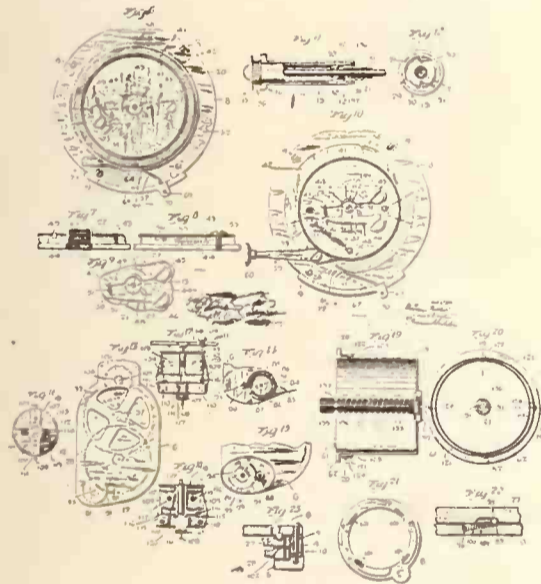

partially broken away; Fig. 2 is a vertical section through the mechanism, taken in the plane of its main axis, the scale being considerably larger than that of Fig. 1; Fig. 3 is a bottom plan view of the mechanism on the scale of Fig. 1; Fig. 4 is an elevation looking at the right-hand end of Fig. 1; Fig. 5 is a reverse end elevation; Fig. 6 is a section on the line 6-6 of Fig. 2; Figs. 7 and 8 are sections on the lines 7-7 and 8-8 of Fig. 6; Fig. 9 is a fragmentary elevation showing the feed nut and return dog in midposition, wherein the thread bar is free to be withdrawn; Fig. 10 is a section on the line 10-10 of Fig. 2; Fig. 11 is a detail view showing the central portion of the mechanism partly in section in the plane of the axis and partly in elevation; Fig. 12 is an enlarged cross-section on the line 12-12 of Fig. 11; Fig. 13 is an elevation of the supporting wall, indicating the gearing in a semi-diagrammatic manner; Figs. 14 and 15 are detail sectional views illustrative of the spring tape winder; Fig. 16 is an end view of the governor, partly broken away and in section; Fig. 17 is a side elevation of the governor; Fig. 18 is a central longitudinal section therethrough; Fig. 19 is a section on the line 19-19 of Fig. 20; Fig. 20 is a cross-section through the record drum on the line 20-20 of Fig. 19; Fig. 21 is an inner face view

of the plate bearing the balls which hold the winding gear against reverse movement; Fig. 22 is an enlarged section on the line 22-22 of Fig. 21, representing the winding gear, and Fig. 23 is a detail sectional view showing the winding and driving gears and one of the ball devices.

SOUND BOX.—John S. Ostrom, San Francisco, Cal. Patent No. 1,166,027.

An object of the invention is to provide a sound box which will cause a clear and correct reproduction of the sound.

Another object of the invention is to provide a sound box in which the vibrations are unhampered in their travel between the stylus and diaphragm.

Referring to said drawings, Fig. 1 is a side view of the sound box of the invention mounted on the sound-conducting arm, the sound box being shown

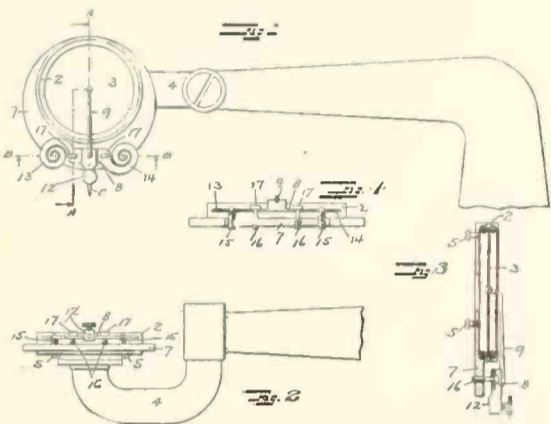

with the stylus at right angles to the arm for purposes of convenience. Fig. 2 is an underneath view of the sound box and arm taken in the position shown in Fig. 1. Fig. 3 is a cross-section of the sound box taken on the line A-A, Fig. 1. Fig. 4 is a cross-section of the sound box taken on the line B-B, Fig. 1.

ADAPTER STYLUS FOR PHONOGRAPHS.—Ellis S. Oliver, Newark, N. J. Patent No. 1,168,412. The present invention relates, generally, to improvements in phonograph apparatus, and the invention has reference more particularly to an adapter stylus which will operate to transmit the vertical vibrations produced by the vertical indentations of a sound record disc to produce horizontal vibrations of a diaphragm of a reproducing sound box set in a vertical plane.

It is the principal object of the present invention, therefore, to provide an interchangeable or detachable adapter stylus adapted to be connected with the ordinary needle socket of the vibrator arm of a vertical sound box, in place of the usual type of needle adapted to play horizontal sound record impressions, so that, without other change, the vertical vibrations of the vertical or "hill-and-dale"

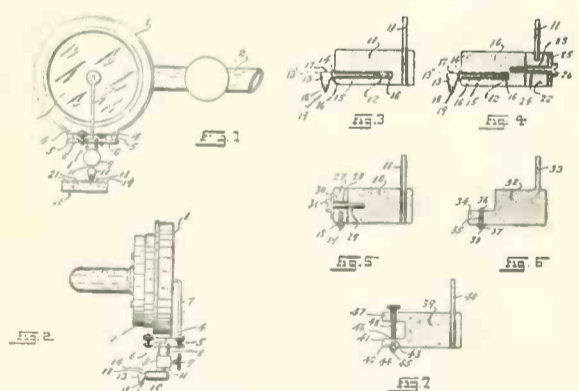

sound record impressions may be transmitted through such adapter stylus to the pivoted vibrator arm and vertical diaphragm of the vertical sound box, so that the latter is adapted to reproduce the sounds recorded upon such type of sound record disc.

Fig. 1 is a face view of a vertical sound box, the vibrator arm of which is equipped with the novel construction of adapter stylus made according to and embodying the principles of the present invention, in this view the said adapter stylus being shown in contact with the vertical sound record impressions of a "hill-and-dale" sound record disc, the latter being shown in section. Fig. 2 is an edge side view of said vertical sound box so equipped. Fig. 3 is a longitudinal vertical section of an adapter stylus made according to and embodying

the principles of the present invention, the same being drawn on an enlarged scale. Fig. 4 is a longitudinal section of a codified construction of said novel adapter stylus. Fig. 5 is a similar view of another modified construction of said novel adapter stylus. Figs. 6 and 7 are, respectively, longitudinal sections of still further modified constructions of the novel adapter stylus.

TONE MODERATOR FOR TALKING MACHINES.—George E. Brightson, Oyster Bay, N. Y., assignor to the Sonora Phonograph Corp., New York. Patent No. 1,167,972.

This invention relates to tone moderators for talking machines, and has for its object to provide an improved device which may be conveniently operated, and which serves to eliminate the objectionable feature of phonographs known as "scratch." The device is so arranged that the passage of the sound is not impeded so as to disadvantageously influence the tone produced by the instrument.

In the accompanying drawings Fig. 1 is a front view of the part of the leader through which the sound passes, with the improved tone moderator applied thereto, arranged within the phonograph case and operated from the outside thereof; Fig.

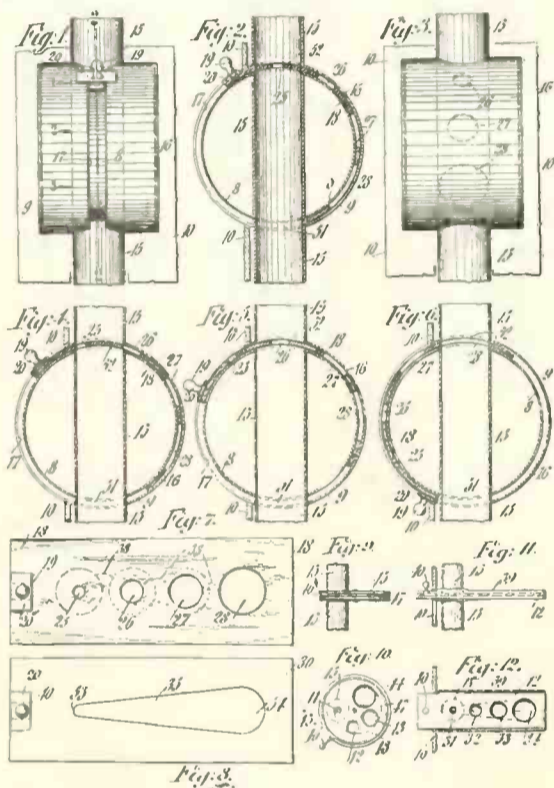

2 is a vertical section taken on line 2-2 of Fig. 1; Fig. 3 is a view of the opposite side of the device from that shown in Fig. 1; Fig. 4 is a section taken on line 2-2 of Fig. 1, but with the valve in a different position from that shown in Fig. 2; Fig. 5 is a similar section with the valve in another position; Fig. 6 is a similar section with the valve in still another position; Fig. 7 is a plan view of the valve, removed from its casing; Fig. 8 is a plan of a modified form of valve; Figs. 9 and 10 are respectively a front view and a plan view, both on a smaller scale than the preceding figures, of another form of valve, in its housings, and Figs. 11 and 12 are respectively a front view and a plan view of another form of the invention.

It is the way you treat a customer that makes the difference between sending him away satisfied and sending him away never to return.

FOR \$1.00 I WILL MAIL 1000 ASSORTED BUSINESS STICKERS as illustrated in this advertisement. Stickers are Poster Stamp style on colored gummed paper. Used to collect accounts— to get more business and to say, Thanks! Desired results are had by sticking one to statement, invoice letter or receipt, etc. Users say "one of these stickers beats a thousand bare words to a frazzle." They leave no sore spots. They cheer to action. Are thoroughly thought out pictured appeals—humorous, semi-humorous, serious and home-striking. Get your order off at once. Wilson E. Rickert, Allentown, Pa.

RECORD BULLETINS FOR APRIL, 1916.

VICTOR TALKING MACHINE CO.

POPULAR SONGS FOR THE MONTH.

No.	Size.	Title	Artist
17935	10	At the Fountain of Youth (McCarron-Gerber-Jentes)	Dan W. Quinn
	10	Hello! Boys, I'm Back Again (Jack Mahoney-Harry von Tilzer)	Dan W. Quinn
17943	10	The Lights of My Home Town (Chas. K. Harris)	Peerless Quartet
	10	There's a Broken Heart for Every Light on Broadway (Fred Fischer-Howard Johnson)	Edna Brown
17959	10	Down in the U-17 (Roger Lewis-Ernie Erdman)	Billy Murray
	10	Since Mother Goes to the Movie Shows (C. McCarron-A. von Tilzer)	Peerless Quartet
17967	10	Young America, We're Strong for You (Wm. McKenna)	Peerless Quartet
	10	Songs We Used to Sing in Dixie Land (Wm. H. Gardner-Caro Roma)	J. Reed-J. F. Harrison
17968	10	Memories (Gustave Kahn-Egbert Van Alstyne)	John Barnes Wells
	10	One Fleeting Hour (Karl Fuhrmann-Dorothy Lee)	Cello obligato by Rosario Bourdon
	10	Elsie Baker	
17969	10	Sweet Cider Time When You Are Mine (Joe McCarthy-Percy Wenrich)	Peerless Quartet
	10	Way Down in Arkansas (James White)	Billy Murray-Irving Kaufman
17970	10	I Love You, That's One Thing I Know (L. Wolfe Gilbert-Anatol Friedland)	Wm. Barnes
	10	Always Be Honey to Me (Branen-Lange-Prival)	Albert Campbell-Henry Burr
17971	10	On the Hoko Moko Isle (Lou Klein-Harry von Tilzer)	Collins and Harlan
	10	When I'm a Sargent Man (Fred Hager)	Collins and Harlan
17972	10	That Soothing Symphony (Will Harris-Ted Snyder)	American Quartet
	10	Those Good Old Days Back Home (Joe McCarthy-Jimmie V. Monaco)	American Quartet
45079	10	You're the Best Little Mother that God Ever Made (J. K. Brennan-Ernest R. Ball)	George MacFarlane
	10	Good Night, Good Night (Ruth K. Gardiner-Ernest R. Ball)	George MacFarlane
17956	10	I'm Neutral (Leon De Costa)	Olive North
	10	I'm a Lonesome Melody (Joe Young-Geo. W. Meyer)	Olive North

DANCE RECORDS.

35528	12	Very Good Eddie—Medley One-step (Jerome Kern)	Victor Military Band
	12	Around the Map—Medley Fox Trot (Herman Finck)	Victor Military Band
35533	12	Bugle Call Rag—Fox Trot. Victor Military Band	Victor Military Band
	12	Some Sort of Somebody, from "Very Good Eddie"—Fox Trot, (Jerome Kern)	Victor Military Band
35534	12	The Princess Pat Waltzes (Victor Herbert)	Victor Dance Orchestra
	12	Somewhere a Voice Is Calling—Medley Waltz	Victor Dance Orchestra

MISCELLANEOUS SELECTIONS.

17928	10	Colombia Waltz, from N. Y. Hippodrome (Mariano Valverde) (Marimba)	Blue and White Marimba Band
	10	Marimba March, from N. Y. Hippodrome (Marimba)	Blue and White Marimba Band
17965	10	Hawaiian Love Song (Barton). Yodling Duet with guitar	Ward Barton-Frank Carroll
	10	Sleep, Baby, Sleep (New Version by Barton). Yodling Duet with guitar	Ward Barton-Frank Carroll
17973	10	Hungarian Dance, No. 5 (Brahms). Cembalom Solo	Joseph Maskowitz
	10	Hungarian Czardas. Cembalom Solo. Also called "Cembalo," "Cymbal" and "Dulcimer"	Joseph Maskowitz
17939	10	Maria, Mari (Di Capua). Neapolitan Song. Violin, 'cello and piano	McKee Trio
	10	Manzanillo (Robyn) Mexican Serenade. Violin, 'cello and piano	McKee Trio
35524	12	Romeo and Juliet Selection (Gounod). Accordion Solo	Pietro Barber
	12	Barber of Seville Overture (Rossini). Accordion Solo	Pietro Barber
35527	12	Midsummer Night's Dream—Nocturne (Mendelssohn)	Victor Concert Orchestra
	12	Midsummer Night's Dream—Intermezzo (Mendelssohn)	Victor Concert Orchestra

MUSICAL COMEDY SUCCESSES.

17974	10	Here Comes Tootsie, from "Around the Map" (C. M. S. McLellan-Herman Finck). With Male Chorus	Alice Green
	10	So Long, Letty, from the musical comedy "So Long, Letty" (Earl Carroll)	A. Green-R. Dixon
35529	12	Gems from "Sybil" (Graham-Jacobi-Smith)	Victor Light Opera Co.
	12	Gems from "Very Good Eddie" (Jerome Kern)	Victor Light Opera Co.

HUMOROUS SPECIALTIES.

17960	10	To My Dog (Comic Specialty)	Billy B. Van
	10	Mickey, the Pum Pum Man (Comic Specialty)	Billy B. Van
35518	12	Jimmy Trigger Returns from the War (Comic Specialty)	Golden and Hughes
	12	Curiosity Hunt (Comic Specialty with Banjo)	Golden and Marlowe

BLUE LABEL RECORDS.

55065	12	Good-Bye (Tosti)	Reinald Werrenrath
	12	Of in the Stilly Night (Thomas Moore)	Reinald Werrenrath

NEW EDUCATIONAL RECORDS.

17937	10	(1) Little Shoemaker (2) Song of Iron, (3) The Blacksmith, from "Songs of Child World" No. 1 (Riley-Gaynor)	Elsie Baker
	10	(1) Baa Baa Black Sheep, (2) How Many Miles to Babylon, (3) Bobby Shafto, (4) Baby Dear, from "Lilts and Lyrics" (Riley-Gaynor)	Olive Kline
35530	12	Country Dance from "Nell Gwyn" (Edward German)	Victor Military Band
	12	Dances from "Henry VIII" (Edward German) (1) Morris Dance, (2) Shepherd's Dance, (Patrick Conway, Director)	Conway's Band
35531	12	The Southerner March (Russell Alexander) (Patrick Conway, Director)	Conway's Band
	12	The Thunderer March (Sousa)	Victor Military Band
35532	12	Dorothy Three-step (Mazurka) (J. B. Lampe)	Victor Military Band
	12	Cupid and the Butterfly (Intermezzo) (Claude d'Albert)	Victor Military Band

RED SEAL RECORDS.

87242	10	Luna d'Estate (Summer Moon) (Riccardo Mazza-F. Paolo Tosti) Tenor Solo, in Italian	Enrico Caruso
-------	----	--	---------------

88552	12	La Reine de Saba—Prête-moi ton aide (Queen of Sheba—Lend Me Your Aid). (Gounod) Tenor Solo in French	Enrico Caruso
64552	10	Dutch Serenade, with harp (S. de Lange. Arr. by Conraad V. Bos). (Poem by Fiore della Neve). Contralto Solo, in Dutch	Julia Culp
64538	10	Menuett in D (Violin Solo) (No. 2) (Haydn-Burmeister). Violin Solo, pianoforte by Walter H. Golde	Mischa Elman
87227	10	Das Steierland ("Hoch vom Dachstein an") (German Folk Song) (Carl Seidel) Soprano and Tenor Duet in German	Alma Gluck and Paul Reimers
87234	10	Wiegenlied (Cradle Song) (Mozart). Soprano Solo in German	Frieda Hempel
64558	10	La Barbançonne (Belgian National Air) (Ch. Rogier-F. Campenhout). Bass Solo in French	Marcel Journet
64557	10	Le Père de la Victoire (Father of Victory). An old French Patriotic Song with new text—dedicated to General Joffré (Louis Ganne) Bass Solo, in French	Marcel Journet
64556	10	Spanish Dance (Endique Granados) (Arr. by Kriesler). Violin Solo, pianoforte by Carl Lamson	Fritz Kreisler
64286	10	Rigoletto—Questa o quella (Mid the Fair Throng) (Act I) (Verdi) Tenor Solo in Italian	Giovanni Martinelli
64428	10	Beautiful Isle of Somewhere (J. B. Pounds-J. S. Fearis) Tenor Solo in English	John McCormack
64521	10	Gondoliera (Boat Song) (Louis Victor Saar) Violin Solo, pianoforte by George Falkenstein	Maud Powell
88549	12	One Sweetly Solemn Thought (Carey-Ambrose) Contralto Solo in English	Ernestine Schumann-Heink

COLUMBIA GRAPHOPHONE CO.

DOUBLE-DISC RECORDS.

Popular Hits of the Month.

No.	Size.	Title	Artist
A1951	10	She's the Daughter of Mother Machree (Ball) Counter-Tenor Solo, orch. accomp.	Manuel Romain
	10	Dear Old-Fashioned Irish Songs My Mother Sang to Me (H. Von Tilzer). Tenor Solo, orch. accomp.	Henry Burr
A1955	10	I Love a Piano (Berlin). Tenor Solo with Chorus, orch. accomp.	M. J. O'Connell
	10	Since Mother Goes to the Movie Shows (McCarron and Von Tilzer). Orch. accomp.	Peerless Quartet
A1950	10	She's Good Enough to Be Your Baby's Mother (Paley). Mezzo-soprano Solo, orch. accomp.	Anna Chandler
	10	No One But Your Dear Old Dad (Marshall). Counter-tenor Solo, orch. accomp.	M. Romain
A1954	10	Good-bye, Red Man (Snyder). Tenor Duet, orch. accomp.	Burr and Campbell
	10	All Aboard for Chinatown (Brookhouse). Baritone and Tenor Duet, orch. accomp.	Arthur Collins and Byron G. Harlan
A1953	10	It Was in the Time of Roses (Bert Grant). Tenor and Baritone Duet, orch. accomp.	Billy Burton and Herbert Stuart
	10	Have You Forgotten Me? (Monaco). Tenor Solo, orch. accomp.	Sam Ash
A1952	10	Katinka (Friml). "Rackety Coo." Soprano and Tenor Duet, orch. accomp.	Grace Nash
	10	I Gave My Heart and Hand to Some One in Dixie Land (Lange). Orch. accomp.	Peerless Quartet

Dance Records of the Month.

A5788	12	Alone at Last (Lehar) introducing "Waltz Entrancing," "Nature Divine," "Thy Heart, My Prize," "One in the Game of Love," and "Pretty Edelweiss." Prince's Orchestra	The Bobolink and the Wren (Bennett)
	12	The Bobolink and the Wren (Bennett). Waltz	Prince's Orchestra
A5786	12	Here Comes Tootsie (Finck)—One-step	Prince's Band
	12	Are You From Dixie? (Cobb, Ball, Elliott and De Coster). One-step. Introducing "You'll Be There," "There's a Long, Long Trail" and "The Little Gray Mother." Prince's Band	
A5750	12	Hello, Hawaii, How Are You? (Schwartz, Abrahams and Jarnagin)—Fox Trot, introducing "Take Me to That Midnight Cake Walk Ball" and "I Didn't Think You'd Care"	Prince's Band
	12	Underneath the Stars (Spencer)—Fox Trot	Prince's Band
A5775	12	Comedy Overture (Lustspiel Overture) (Keller Béla)	Prince's Orchestra
	12	Tales of Hoffmann (Offenbach). Barcarolle	Prince's Orchestra
	12	BLUE-LABEL DOUBLE-DISC RECORDS.	
A1939	10	Hello, Hawaii, How Are You? (Schwartz). Mezzo-soprano, orch. accomp.	Anna Chandler
	10	When You're Down in Louisville (Berlin). Mezzo-soprano, orch. accomp.	Anna Chandler
A1940	10	Casey as a Judge. Comedy Monologue	Michael Casey
	10	Mrs. Dugan's Discovery (Ellis Parker Butler). Comedy Monologue	Steve Porter
A1941	10	Murmuring Zephyrs (Jensen-Prince)	Columbia Stellar Quartet
	10	The Maid of the Valley (Herbeck)	Columbia Male Quartet
A1930	10	Moment Musical (Schubert). Prince's Orchestra	Prince's Orchestra
	10	Andante Cantabile (Tschaiakowsky)	Prince's Orchestra
A1946	10	Easter Chimes (Lake)	Prince's Orchestra
A1936	10	Dawn of Hope (De Casella). Prince's Orchestra	Prince's Orchestra
	10	The Modest Susanna (Gilbert)	Royal Marimba Band
	10	The Flag of Guatemala (Hurtado)	Royal Marimba Band
A1935	10	On the Beach at Waikiki (Kailimai). Ukulele Duet	Helen Louise and Frank Ferera
	10	Hapa Haole Hula Girl. Ukulele Duet	Helen Louise and Frank Ferera
A1934	10	Massa's in the Cold, Cold Ground (Foster). Piano, violin and 'cello accomp.	Taylor Trio
	10	Darling Nellie Gray (Hanby). Piano, violin and 'cello accomp.	Taylor Trio
A1956	10	Yaska, Hoola, Hickey. Doola (Goetz, Young and Wendley). Baritone Solo, orch. accomp.	Al Jolson
	10	You Can't Get Along With 'Em or Without 'Em (Fischer). Mezzo-soprano Solo, orch. accomp.	Anna Chandler
A1949	10	The Palms (Faure). Tenor and Baritone Duet, orch. accomp.	H. Burr and A. Wiederhold
	10	The Resurrection (Shelley). Baritone Solo, orch. accomp.	Albert Wiederhold

A1948	10	Debutante Intermezzo (Kopp). Xylophone and bell solo with band accomp.	Howard Kopp
	10	The Ladder of Roses (Hubbell). Bell Solo with orch. accomp.	Howard Kopp
A5784	10	The Holy City (Gaul). "List, the Cherubic Host." Bass Solo, orch. accomp.	F. Croxton and Columbia Ladies' Quartet
	12	Hymn to the Madonna (Kremser). Orch. accomp.	Columbia Oratorio Chorus
A5785	12	Some Day I'll Wander Back Again (Huntley). Contralto Solo, with orch. accomp.	Margaret Keyes and Columbia Stellar Quartet
	12	Will You Love Me When I'm Old? (Ford) Contralto Solo, orch. accomp.	Margaret Keyes
	12	SYMPHONY DOUBLE-DISC RECORDS.	
		Selections from Bach's "Cello Suite, Played by Pablo Casals.	
A5782	12	Suite in C Major: Prelude (J. S. Bach). 'Cello Solo	Pablo Casals
	12	Suite in C Major; Saraband (J. S. Bach) 'Cello Solo	Pablo Casals
A5779	12	Come, Where My Love Lies Dreaming (Foster). Baritone Solo, orch. accomp.	Oscar Seagle
	12	Carry Me Back to Old Virginia (Bland). Baritone Solo, orch. accomp.	Oscar Seagle
		Maggie Teyte Operatic and Concert Star Renders Two Exquisite Ballads.	
A1938	10	Little Gray Home in the West (Löhr). Soprano Solo, orch. accomp.	Maggie Teyte
	10	Until (Sanderson). Soprano Solo, orch. accomp.	Maggie Teyte
A1937	10	Princess Pat (V. Herbert). "Love Is the Best of All." Soprano Solo, orch. accomp.	Eleanor Painter
	10	Lilac Domino (Cuvillier). "The Lilac Domino" Soprano Solo, orch. accomp.	Eleanor Painter

NEW EDISON DIAMOND DISC RECORDS.

50325	10	Back Home in Tennessee (Donaldson). Tenor Solo with chorus	George Wilton Ballard
	10	M-O-T-H-E-R (A Word that Means the World to Me) (Morse). Tenor Solo	Geo. Wilton Ballard
50326	10	Bridal Blushes Waltz (Schmid). For dancing	Judas' Society Orchestra
	10	Lake of the Woods Waltz (Barry). For dancing	Judas' Society Orchestra
50327	10	Cohen at the Telephone. Monolog.	G. L. Thompson
	10	I've Been Floating Down the Old Green River (Cooper). Tenor Solo	Billy Murray
50328	10	Along the Rocky Road to Dublin (Grant). Male voices	Premier Quartet
	10	In Monterey (Moret). Tenor Solo	Burton Lenthian
50329	10	Sons of Mother Earth—He Comes Up Smiling (Ward). Male voices	Weary Wilkie Trio
	10	When the Right Girl Comes Along—Around the Map (Finck). Tenor Solo with chorus	Billy Murray
50330	10	Mister Silver Moon (Weberbauer). Soprano and Tenor Duet	Gladys Rice and Irving Kaufman
	10	Could the Dreams of a Dreamer Come True (Lange). Tenor Solo	George Wilton Ballard
50331	10	Trumpeter of Säckingen—Parting Song (Nessler). Cornet Solo	Louis Katzman
	10	With Sword and Lance March (Starke)	New York Military Band
50332	10	Dancing with Ma Honey (Losey). Xylophone Solo	Charles Daah
	10	Twinkle Waltz (Vanderpool and Reimer). Zylophone Solo	Charles Daah
50333	10	Loading Up the Mandy Lee (Marshall). Male voices	Premier Quartet
	10	Some Little Bug is Going to Find You—Alone at Last (Hein). Tenor Solo	Walter Van Brunt
80279	10	A Little Love, a Little Kiss (Would Go a Long Way) (Hill). Contralto and Baritone Duet	Helen Clark and Joseph A. Phillips
	10	They Didn't Believe Me (Kern). Soprano and Tenor Duet	Gladys Rice-Walter Van Brunt
80287	10	Andante pastorale, from "Souvenir des Alpes" (Bohm). Flute Solo	Wevert A. Moor
	10	Berceuse—Jocelyn (Godard) Violoncello Solo	Herman Sandby
80288	10	Ah! Could I But Once More So Love, Dear (Aletter). Tenor Solo	Emory B. Randolph
	10	Nightingale—Vocal Waltz. (Batten). Mixed voices	Metropolitan Quartet
80289	10	Pretty Edelweiss—Alone at Last (Lehar). Soprano Solo	Mary Carson
	10	Teach Me to Smile—The Girl Who Smiles (Briquet and Phillip). Soprano and Tenor Duet	Mary Carson and George Wilton Ballard
82539	10	Explanatory Talk for Ah, fors'e lui ('Twas he, perchance)—La Traviata (Verdi)	Soprano Solo in Italian. Lucrezia Bori
82540	10	Explanatory Talk for O du mein holder Abendstern (The Evening Star)—Tannhauser (Wagner)	Tenor Solo
	10	O du mein holder Abendstern (The Evening Star)—Tannhauser (Wagner). Bass Solo in German	Arthur Middleton
83040	10	Explanatory Talk for Schmiedelied (Forge Song), Siegfried (Wagner)	Schmiedelied (Forge Song), Siegfried (Wagner). Tenor Solo

PATHE FRERES PHONOGRAPH CO.

No.	Size.	Title	Artist
30379	11½	You Go Your Way and I'll Go Mine (J. W. and J. R. Johnson). Tenor Duet, orch. accomp.	Ada Jones and M. J. O'Connell
	11½	When I Get Back to the U. S. A. from "Stop! Look! Listen!" (Irving Berlin). Tenor Solo, orch. accomp.	M. J. O'Connell
30380	11½	When You're Down in Louisville (Irving Berlin). Duet, orch. accomp.	Collins and Harlan
	11½	The Ghost of the Terrible Blues (H. Von Tilzer). Orch. accomp.	Peerless Quartet
30381	11½	Are You From Dixie (Jack Wellen and Geo. L. Cobb). Orch. accomp.	Peerless Quartet
	11½	Honey Bunch (A. B. Sterling and Dan. Caslar). Duet, orch. accomp.	Collins and Harlan
30401	11½	Absent (John W. Metcalf). Orch. accomp.	New York Male Quartet
	11½	The Lamp in the West (Horatio Parker, Op. 48 No. 1). Orch. accomp.	New York Male Quartet
30402	11½	Always Be Honey To Me (Branen, Lange and Prival). Duet, orch. accomp.	Burton and Hall
	11½	Is There Still Room for Me 'Neath the Old Apple Tree, (Leslie, Brown and Abrahams). Duet, orch. accomp.	Campbell and Burr
30403	11½	When It's Orange Blossom Time in Loveland (Jeff Branen and Arthur Lang). Duet, orch. accomp.	Burton and Hall
	11½	When You're Dancing the Old Fashioned Waltz (Chas. McCarran and A. Von Tilzer). Duet, orch. accomp.	Campbell and Burr
30382	11½	The Minstrel Boy (Irish National Song). Tenor Solo, orch. accomp.	Harry McClaskey

AN ESTABLISHED AND SUCCESSFUL TALKING MACHINE LOCATION FOR RENT in the FIFTH AVENUE BUILDING, which faces Madison Square, at the Junction of Fifth Avenue, Broadway and Twenty-third Street.

THE STORE at Number Nine West Twenty-third Street, with show windows on the Fifth Avenue Building Arcade as well as on the street, IS FOR RENT.

The Fifth Avenue Building is managed by its owners, with whom negotiations can be made direct at their office in the building.

The Fifth Avenue Building Company

<p>The Harp that Once Through Tara's Hall (Irish National Song). Tenor Solo, orch. accomp. Harry McClaskey 11½</p> <p>10060 Cavalleria Rusticana "Intermezzo" (Mas-cagni). Violin Solo, orch. accomp. Jan Rudenyi 10½</p> <p>Spring Song (Mendelssohn). Violin Solo, orch. accomp. Jan Rudenyi 10½</p> <p>30392 Tantum Ergo (Vito Giannatelli). Baritone Solo, organ accomp. Rev. Francis Auriemma 11½</p> <p>O Salutaris (Vito Giannatelli). Baritone Solo, organ accomp. Rev. Francis Auriemma 11½</p> <p>30400 Love's Old Sweet Song (G. Clifton Bingham and J. L. Molloy). Contralto Solo, orch. accomp. Henrietta Turell 11½</p> <p>The Two Beggars (H. Lane Wilson). Duet with orch. accomp. R. Miller-F. Croxton 11½</p> <p>30377 There's a Wee Bit of Blarney in Killarney (Jackson, Gilhert and Ager). Baritone Solo, orch. accomp. James Hall 11½</p> <p>Everything in America is Ragtime, from "Stop! Look! Listen! (I. Berlin). Soprano Solo, orch. accomp. Grace Nash 11½</p> <p>30333 American Patrol (Medley) Pathé Military Band Serenade (Moszkowsky). Pathé Military Band 11½</p> <p>30383 Lucy's Sextet (Harry L. Alford). A ragtime travesty on the Famous Sextet from "Lucia"—One or Two-step. Pathé Dance Orchestra 11½</p> <p>Red Raven Rag (Charley Straight). — One or Two-step. Pathé Dance Orchestra 11½</p> <p>70145 A—Hungarian Rhapsody No. 2 (Liszt). Part 1 Pathé Symphony Orchestra 14</p> <p>B—Hungarian Rhapsody No. 2 (Liszt), Part 2 Pathé Symphony Orchestra 14</p> <p>70148 Valse Banffy..Hungarian Orchestra, Budapest 11½</p> <p>Valse Mauve..Hungarian Orchestra, Budapest 11½</p> <p>20000 The Dear Little Shamrock (Jackson), Tenor Solo, orch. accomp. J. C. Doyle 10½</p> <p>The Green Isle of Erin (Roekell). Contralto. Solo, orch. accomp. Carrie Herwin 10½</p> <p>30325 The Story of Little Goldilocks and The Three Bears. Part 1. As told by Aunt Polly 11½</p>	<p>The Story of Little Goldilocks and The Three Bears. Part 2. As told by Aunt Polly 11½</p> <p>30332 Hearts and Flowers (Tohani). Intermezzo... Imperial Symphony Orchestra 11½</p> <p>Melody in "F" (Rubinstein)..... Imperial Symphony Orchestra 11½</p> <p>30331 Mon Bijou (Le Paige)—Waltz..... Imperial Symphony Orchestra 11½</p> <p>In the Shadows (Finck). With bells..... Imperial Symphony Orchestra 11½</p>	<p>2831 Could the Dreams of a Dreamer Come True (Arthur Lange). Tenor Solo, orch. accomp. George Wilton Ballard 11½</p> <p>2834 I'm Dreaming of You (Ward Barton). Yodel Song, orch. accomp. Ward Barton 11½</p> <p>2840 In Monterey (Neil Moret). Tenor Solo, orch. accomp. Burton Lenihan 11½</p> <p>2841 Little Love, a Little Kiss (Would Go a Long, Long Way) (May Hill). Contralto and Baritone Duet, orch. accomp. Helen Clark and Joseph A. Phillips 11½</p> <p>2844 Lorna (Ernest Newton). Tenor Solo, orch. accomp. Emory B. Randolph 11½</p> <p>2843 America, I Love You—March (Archie Gottler) New York Military Band 11½</p> <p>2824 Back Home in Tennessee (Walter Donaldson) Armand Vecsey and His Hungarian Orchestra 11½</p> <p>2833 Cirihihihin (A. Pestalozza)..... Sodero's Band 11½</p> <p>2836 Hezekiah—Cake Walk (Don Richardson) for dancing National Promenade Band 11½</p> <p>2825 I'm on My Way to Dublin Bay—Humorous Patrol (Murphy-Lampe)...New York Military Band 11½</p> <p>2829 Universal Fox Trot (Joe Rosey) for dancing. Vess L. Ossman's Banjo Orchestra 11½</p> <p>2827 Loading Up the Mandy Lee (Henry Marshall. Male Voices, orch. accomp. Premier Quartet 11½</p> <p>2828 Nightingale—Vocal Waltz (Robert Batten). Mixed Voices, orch. accomp. Metropolitan Quartet 11½</p> <p>2823 Some Little Bug is Going to Find You, from "Alone at Last" (Silvio Hein). Tenor Solo, orch. accomp. Walter Van Brunt 11½</p> <p>2830 Sons of Mother Earth—He Comes Up Smiling (Ted. D. Ward). Male Voices, orch. accomp. Weary Willie Trio 11½</p> <p>2837 Iolanthe Airs—No. 1 (Gilbert-Sullivan)..... New York Light Opera Company 11½</p> <p>2826 Mocking Bird (Septimus Winner). Soprano and Tenor Duet, orch. accomp. Elizabeth Spencer and Walter Van Brunt 11½</p>
--	--	---

EDISON BLUE AMBEROL RECORDS.

CONCERT LIST.

28226 Madre, Pietosa Verg'ne—La Forza del Destino, (G. Verdi). Soprano Solo in Italian, orch. accomp. Julia Heinrich and Male Chorus 11½

28227 Recitative and Air—He Shall Feed His Flock from "Messiah" (G. F. Handel). Contralto Solo, orch. accomp. Christine Miller 11½

REGULAR LIST.

2838 And the Great Big World went 'Round and 'Round (Harry von Tilzer). Baritone and Tenor Duet, orch. accomp. Arthur Collins and Byron G. Harlan 11½

2839 I Love a Piano—Stop! Look! Listen!. Tenor Solo with Chorus, orch. accomp. W. Van Brunt 11½

2842 I've Been Floating Down the Old Green River (Joe Cooper). Tenor Solo, orch. accomp. Billy Murray 11½

2835 There's a Long, Long Trail (Zo. Elliott). Tenor Solo with Chorus, orch. accomp. George Wilton Ballard 11½

2845 When I Get Back to the U. S. A., from "Stop! Look! Listen" (Irving Berlin). Tenor Solo with Chorus, orch. accomp. Billy Murray 11½

2832 Bells of Lee (Stephen Adams). Contralto Solo, orch. accomp. Helen Clark 11½

READY REFERENCE OF GENERAL SUPPLIES

DEALERS

Send for our "Trial Proposition" on the Regina Hexaphone—the latest and best paying popular priced coin-operated instrument for use in public places.



211 Marbridge Bldg., 34th St. and Broadway, New York City
Manufacturers of Regina Music Boxes; Reginaphones;
Coin-operated Mandolin Orchestrions; Vacuum
Cleaners and other specialties

Mermod & Co.

505 Fifth Avenue New York

Manufacturers of

Talking Machine Supplies

Motors—Sapphire Points

Diamond Points a Specialty

Keep Your Record Stock with



Costs about \$2.00 for 250 records for 50 years
Send for 20-page catalog

THE SYRACUSE WIRE WORKS,
SYRACUSE NEW YORK

Leading Jobbers of Talking Machines in America

SERVICE FIRST
 EXCLUSIVE VICTOR JOBBERS
 WHOLESALE ONLY
Standard Talking Machine Co.
 PITTSBURGH, PA.

Victor Exclusively
EASTERN TALKING MACHINE CO.
 177 Tremont Street, Boston
VICTOR DISTRIBUTORS

Sherman, Clay & Co.
 San Francisco, Los Angeles, Portland, Seattle, Spokane
PACIFIC COAST DISTRIBUTORS
 Victrolas and Victor Records, Steinway Pianos, Pianola
 Pianos, Holton Band Instruments

Chase & West DES MOINES, IOWA

Victor Distributors
 All orders shipped the same day received
 Service to all points

Pathé
 17 NORTH WABASH
 CHICAGO

The Chicago Edison Jobber
 The perfection of Musical Instruments—THE EDISON diamond disc PHONOGRAPH—with EDISON double disc records.
 THE PERFECTION OF SERVICE—Our Service.
 The Perfection of advertising for the dealer—Our plan.
The Phonograph Company
 229 So. Wabash Ave. CHICAGO

W. J. DYER & BRO.
 Saint Paul, Minn.
VICTOR & EDISON Distributors
 Quick Service for all points in the Northwest. Machines, Records, Supplies.

Southern Victor Dealers
 Largest Stock VICTROLAS and RECORDS.
 Prompt Shipment and Low Freight Rates.
WALTER D. MOSES & CO.
 Oldest Music House in Virginia or North Carolina.
 RICHMOND, VA.

OLIVER DITSON COMPANY
 Largest VICTOR Talking Machine Distributors East of Chicago.
 Creators of "The Fastest Victor Service." Let us tell you more about our service.
BOSTON

1856 **WURLITZER** 1916
VICTOR DISTRIBUTORS
 VICTORS EXCLUSIVELY
 We make a specialty of getting the order out on time—every time.
The Rudolph Wurlitzer Co.
 CINCINNATI and CHICAGO
 Two points of supply; order from the nearer.

The PHONOGRAPH CORPORATION
 of MANHATTAN—New York
 Distributors of Edison Diamond Disc Phonographs
 The greatest musical instrument ever produced. As a business builder it is likewise superior.
 Ask us for particulars
 JERSEY CITY

GATELY-HAIRE CO., Inc.
 If it's Victor we have it
 We have it if it's Victor
 ALBANY, N. Y.

The Perry B. Whitsit Co.
 DISTRIBUTORS OF
Victrolas and Victor Records
 COLUMBUS, OHIO

EVERY JOBBER IN THIS COUNTRY SHOULD BE REPRESENTED IN THIS DEPARTMENT. THE COST IS SLIGHT AND THE ADVANTAGE IS GREAT. BE SURE AND HAVE YOUR CARD IN THIS DEPARTMENT OF THE TALKING MACHINE WORLD.

SYSTEMATIZER FOR RECORD STOCK.

Interesting Letter Bearing on the Above Sent Out by the Victor Talking Machine Co.

The Victor Talking Machine Co. sent out to its dealers this week a very important letter announcing a systematizer for record stock. The system is outlined by the Victor Co. as follows:

"Realizing the importance and necessity of every Victor dealer and record salesman becoming more familiar with the Victor record catalog, we have at great expense and labor printed a heavily gummed label, containing complete information for every Victor record in the domestic section of the Victor catalog.

"Each label contains: First—A complete cross index of each selection, showing all other records of this selection in the Victor catalog giving the number and by whom made. Second—Record number at each end of label, so that it is always visible.

"When attached to stock envelopes, the service these labels render is invaluable, particularly during the rush hour, or holiday season. As an illustration:

"A customer desires Record No. 17,234, 'The Rosary.' Dealer or salesman (especially if he is a new man) finds no stock of this particular number, but the label on the stock envelope, or card in the bin, immediately informs him that there are eleven other records of 'The Rosary,' and gives him the numbers and the artists. This enables the dealer or salesman to secure such information instantly, without referring to the catalog, and enables him to return to his customer, not 'with regrets,' but with other records of 'The Rosary,' which he may demonstrate and dispose of and thus avoid disappointing the customer. This service cannot be over-estimated."

The Singer Phonograph Co. has been incorporated at Chicago with a capital of \$9,000 by Lon L. Bartlett, L. R. Martin and Deral C. Bartlett.

ARTISTIC PATHE HANGER.

The Pathé Frères Phonograph Co., New York, sent out to its dealers this week a very artistic hanger featuring a special list of Pathé discs which go on sale this month. This hanger also served to call the attention of Pathé dealers to the fact that the Pathé Frères Co. had closed an exclusive recording contract with Lucien Muratore, the famous tenor.

The Pathé Frères Co. has conceived a standard form of supplement hanger design which has won the approval of the company's dealers throughout the country. The hanger is dignified and attractive, and presents a pleasing appearance in the dealer's window.

LEWIS BROS. HANDLING VICTROLAS.

The Lewis Bros. Co., of East Liverpool, O., has arranged to handle the complete Victrola line in that city.

3/15/16

THE INSTRUMENT OF QUALITY

Sonora

CLEAR AS A BELL



THE INVINCIBLE

(Construction and Design Patented) \$300.00
Oak or Mahogany, all finishes
Circassian Walnut, \$50.00 extra

12-inch Turntable. Extra Heavy. Triple-spring Motor. Gold-plated, playing three-quarters of an hour, or fifteen 10-inch records, in one winding. Motor Meter. Spring Control. Tone Modifier. Multi-playing Needle. Sapphire Needle. Diamond Needle. Automatic Starter and Stopper. Equipment for playing all makes of disc records in the world. Trimmings Gold-plated. Envelope Filing System with capacity for 110 records.

Dimensions:

Width, 21¼ in. Height, 50 in. Depth, 21¼ in.

“ ” We Quote

Mr. O. H. Fernbach, Secretary International Award System, who writes from San Francisco to the Sonora Phonograph Corporation under date of February 8, 1916:

“I beg to inform you that the only Jury which heard and tested all the phonographs exhibited at the Panama-Pacific International Exposition recommended that the Sonora be given a marking for tone quality higher than that given to any other phonograph or talking machine.”

Read this over again. Note the words “all the phonographs,” “tone quality,” “marking” and “higher.” Then hear a Sonora and find out for yourself *why* expert judges gave the decision they did.

Would you like to handle the Sonora? Write us and we may be able to make suitable arrangements.

SONORA PHONOGRAPH CORPORATION

GEORGE E. BRIGHTSON, *President*

General Offices and Salesrooms:

57 READE STREET

NEW YORK CITY

The INCOMPARABLE NEW EDISON



CHIPPENDALE
Official Laboratory Model

Not an idle assertion but a compelling fact. Here is evidence:

"The genius of Edison stood out supreme last night. . . . It was brought home to the audience superbly, impressively. Those who heard this astounding Tone Test were amazed and mystified, none could tell how this miracle of Re-Creating the human voice had been accomplished, but all were ready and willing to say that it had been done and they had heard it. *Only with Edison's Instrument is a Tone Test possible.* Nothing like it has ever been heard before. It was as daring, as acid-testing a demonstration as any invention has ever been submitted to.

"It was baffling. Had two Christine Millers stood last night beside the cabinet, singing simultaneously, the effect could not have been more perfect. The living and Re-Created voices were one in tone, color, shade and quality. It was a triumph of Edison's genius which made such a marvelous Tone Test possible."

Comment of the *Journal Courier*, New Haven, Conn., on a recent Tone Test.

Music lovers who taboo "mechanical music" are the most enthusiastic Edison owners. Thus, the New Edison has opened up a field untouched by any other sound-reproducing device, and given the Edison dealer the broadest selling horizon possible.

For dealer's terms address us or the jobber in the list below nearest you.

THOMAS A. EDISON, Inc., 279 Lakeside Ave., Orange, N. J.

JOBBER'S OF EDISON PHONOGRAPHS AND RECORDS:

CALIFORNIA
Los Angeles—Southern California Music Co.
San Francisco—Pacific Phonograph Co.
COLORADO
Denver—Denver Dry Goods Co.
CONNECTICUT
New Haven—Pardee-Ellenberger Co.
GEORGIA
Atlanta—Phonographs, Inc.
ILLINOIS
Chicago—The Phonograph Co.
INDIANA
Indianapolis—Kipp Phonograph Co.
IOWA
Des Moines—Harger & Blish.
Sioux City—Harger & Blish.
LOUISIANA
New Orleans—Diamond Music Co., Inc.
MAINE
Bangor—Chandler & Co.

NEW YORK
Albany—American Phonograph Co.
New York—The Phonograph Corp. of Manhattan.
Syracuse—Frank E. Bolway & Son.
OHIO
Cincinnati—The Phonograph Co.
Cleveland—The Phonograph Co.
OREGON
Portland—Pacific Phonograph Co.
PENNSYLVANIA
Philadelphia—Girard Phonograph Co.
Pittsburgh—Buehn Phonograph Co.
Williamsport—W. A. Myers.
TEXAS
Dallas—Texas-Oklahoma Phonograph Co.
El Paso—El Paso Phonograph Co., Inc.
UTAH
Ogden—Proudfit Sporting Goods Co.
MASSACHUSETTS
Boston—Pardee-Ellenberger Co.
MICHIGAN
Detroit—Phonograph Co. of Detroit.

MINNESOTA
Minneapolis—Laurence H. Lucker.
MISSOURI
Kansas City—The Phonograph Co. of Kansas City.
St. Louis—Silverstone Music Co.
MONTANA
Helena—Montana Phonograph Co.
NEBRASKA
Omaha—Shultz Bros.
VIRGINIA
Richmond—C. B. Haynes & Co.
WASHINGTON
Seattle—Pacific Phonograph Co., N. W.
Spokane—Pacific Phonograph Co.
WISCONSIN
Milwaukee—The Phonograph Co. of Milwaukee.
CANADA
Montreal—R. S. Williams & Sons Co., Ltd.
St. John—W. H. Thorne & Co., Ltd.
Toronto—R. S. Williams & Sons Co., Ltd.
Vancouver—Kent Piano Co., Ltd.
Winnipeg—R. S. Williams & Sons Co., Ltd.
Calgary—R. S. Williams & Sons Co., Ltd.