

*****ALL FOR 200
0101 00000000 0000 0000
PARRY NICHKIND
2005 5 AUGUSTA PL
TUCSON AZ 85712

RadioWorld®

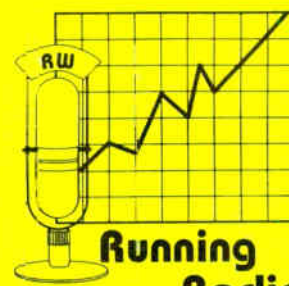

Running
Radio
See pp. 65-83

Vol 18, No 19

Radio's Best Read Newspaper

September 21, 1994

Beware of OSHA's RFR Rules

by John Gatski

WASHINGTON Federal Occupational Health Safety Administration (OSHA) rules regarding protection of workers and the public from energy-generating devices are generally unknown to most broadcasters, but these regulations can land them substantial fines.

Just ask Chris Scott, chief engineer for Western Kentucky's Public Radio in Bowling Green, Ky. Scott's station, WKPB-FM, and others were fined \$2,000 in 1991 for two OSHA violations regarding lockout/tagout procedures when working on a tower.

Kentucky Educational Television (KET) also was fined—even more

money—because it owned the tower sites which contained several users. These fines were later negotiated down because of stations' cooperation with the agency, according to Scott.

Procedural violations

The citations were issued in 1991 for procedural violations of Kentucky OSHA Rule 1910.147, which is based on federal OSHA rules. The first citation stated that WKPB's "procedures were not developed, documented and utilized for the control of potentially hazardous energy when employees were engaged in activities covered by this section." The station also was cited for not training employees "in the purpose and the function of the

Energy Control Program."

"It is one of the best kept secrets," Scott said of the OSHA regulations.

According to Scott, the OSHA inspection came about because the KET had hired a full-time tower climber, who apparently became disgruntled and contacted OSHA officials.

Scott, however, said that at the time of the OSHA inspection, he was confident that the station was complying with applicable rules. "I couldn't imagine that we were in violation," Scott said when the OSHA inspectors came to the station in Bowling Green.

He said the station always turned its power down to 15 percent to meet the 1982 ANSI RF emission standard when a worker climbed the tower. (The FM antenna for half of Kentucky's public radio stations is co-located with the public TV station tower; the towers also have other users including two-ways.)

A surprise

However, a few days after the inspection, OSHA returned with the violation notices, termed as "serious." The station was not in violation of subjecting a worker to excessive RF radiation, but only the procedural violations.

Scott said the Kentucky public TV and radio networks appealed fines through continued on page 11 ▶

New NPR Facility Nets Modern, Roomy Studios

by Alan Haber

WASHINGTON At first glance, the reflecting, seven-floor triangular building on Massachusetts Avenue, bookended by 7th and K Streets in the northwest quadrant of the nation's capital, seems unassuming. A brisk, two-block walk from Chinatown, the building houses the neighborhood branch of American Security Bank, which

continued through Monday, Feb. 21, when the 5:00 a.m. newscast originated from the new building. (NPR broadcast from studios at the Voice of America during the long weekend.)

The move succeeded splendidly, despite Washington's brutal, icy winter weather, delayed permits and the seemingly never-ending procession of trucks pulling up to the loading dock, packed tightly with 20 years of equipment and memories amassed at NPR's M Street location. The Public Radio Satellite System, operated by NPR's Distribution Division, distributes audio programming to public radio stations and provides satellite backhaul and distribution services to a variety of public and commercial customers.

A small one-story building, located at 613 Massachusetts Avenue, is occupied by the Distribution Division's Future Interconnection System Project Office (FISPO), whose mission is updating and replacing the operating and support equipment for the public radio satellite system. A parcel of land east of number 613 was also purchased by NPR with an eye toward future expansion.

Support

Supporting just over 500 member stations throughout the country, NPR is a nonprofit, noncommercial, satellite-delivered radio system attracting nearly 15 million listeners

continued on page 9 ▶



NPR's Control Room and Studio 2A

used to occupy the entire building as its headquarters.

Spacious and warm

It is not until you cross Massachusetts Avenue that you realize this is the new home of National Public Radio. Above the entrance to the building, the familiar NPR logo greets staff and visitors. Photographs spanning NPR's current complement of personalities hang on the walls of the busy lobby, which is spacious and warm.

The move to 635 Massachusetts Avenue, in which NPR occupies just over 150,000 square feet, took place over a 72-hour period that began February 17, 1994, and

WORLD MEDIA EXPO

P • R • E • V • I • E • W

See pp. 15-50

PRICE REDUCTION
Complete System
Starting at \$17,950

**Orban DSE 7000
Digital Editor**

So fast, you'll have the time to be creative and productive. Produce the highest quality digital spots in one-third the time. Call us toll-free.

Phone: 800-622-0022 Fax: 317-966-0623

HARRIS ALLIED

Circle (100) On Reader Service Card

NEWSWATCH

World College Accredited

VIRGINIA BEACH, Va.

The Commonwealth of Virginia Council of Higher Education recently approved the World College to offer a Bachelor of Electronics Engineering Technology degree through its independent study program.

World College is an affiliate of the Cleveland Institute of Electronics and offers extensive electronics courses plus the necessary liberal studies courses

required by Virginia for bachelors degree.

For information, call Denise Zakrajsek at 800-243-6446.

Consultants To Speak at NAB

WASHINGTON Eight program consultants were selected by the NAB to give ten minute "state of the format" addresses to begin each format fair at the NAB Radio Show next month in Los Angeles.

The 10-minute addresses are a

new feature added to the 75-minute format fairs—roundtable discussions devoted to a variety of format-specific topics.

The eight consultants, described by the NAB as the top format consultants in the industry, are Mike McVay of Cleveland, who will be discussing Adult Contemporary formats; Alan Burns of Oakton, Va., who will be discussing Top-40 formats; Jay Albright of Seattle, who will be discussing Country formats; Steven Humphries of San Antonio, who will be discussing

Hispanic formats; Rob Balon of Austin, Texas, who will be discussing News-Talk-Sports formats; Dave Allen of Las Vegas, who will be discussing Oldies formats; Lee Abrams of Dallas, who will be discussing Rock formats and Tony Gray of Chicago, who will be discussing Urban formats.

MAB Officers Elected

LANSING, Mich. The Michigan Association of Broadcasters recently elected its 1994-1995 board of directors and officers. The officers are Tom Scanlan, president; Stephen C. Trivers, vice-president and Eric S. Land, treasurer.

NAB Urges FCC To Reject Fairness Doctrine Push

WASHINGTON The National Association of Broadcasters (NAB) is among four media organizations calling on the FCC to reject a request by a California anti-smoking group to reimpose the Fairness Doctrine for ballot issues.

The NAB, along with the Radio-Television News Directors Association, the Media Institute and the Reporters Committee for Freedom of the Press contend that the FCC's 1987 repeal of the Fairness Doctrine applies to all publicly discussed issues, including ballot issues.

Before its repeal, the Fairness
continued on next page ▶

Just RIGHT!

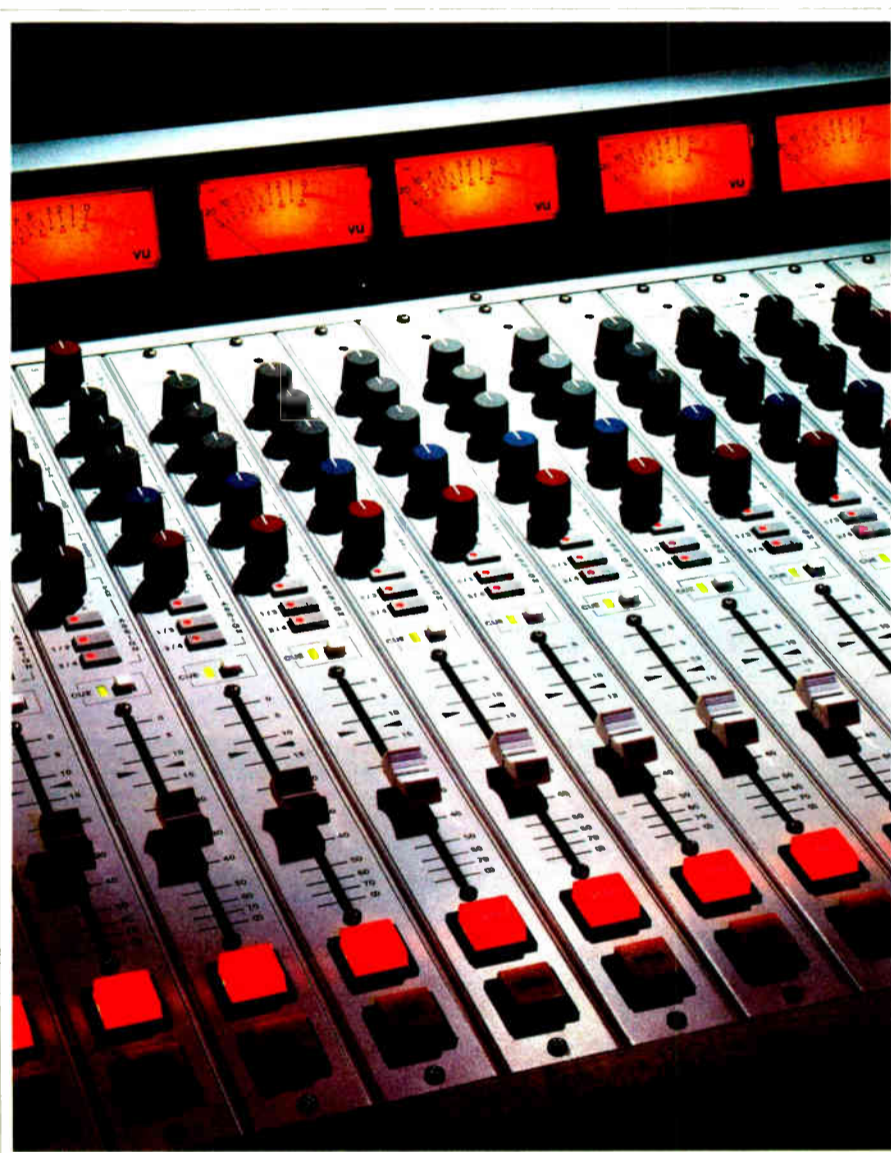

MR-40

MULTI-TRACK PRODUCTION doesn't have to be complicated. The MR-40 has just the features most stations are looking for: 4-track bus assign for your tape recorder; program assign so you can transfer direct to your 2-track—or go right on-air! It has machine Start/Stops just below the fader like an on-air console, but also includes a 3-band equalizer section so you can have the tone control that a normal radio console couldn't provide. It even has a stereo send bus that follows stereo channel balance controls—ever so important for today's stereo effects devices.

Mono modules have both mic and line inputs: mic for recording and line for track playbacks. Subgroup channels provide fader control for record levels and also have a second

track playback path for really quick sessions. And of course the MR-40 has an on-air type monitor section, complete with control room, headphone and studio outputs, plus all the necessary muting and tally functions you'd want. It even has a built-in cue speaker and power amplifier.

Small format doesn't mean we've cut corners either: all audio switches are gold contact; assign buttons are LED illuminated; all ICs are double burned-in, and all circuits are double-tested—we don't take any chances with reliability! The MR-40 is a perfect blend of excellence in engineering and sensible size. It's just right for 4-track analog and digital work stations—it can even back up your on-air console! So contact Audioarts.

7305 Performance Drive, Syracuse, NY 13212 (315-452-5000/Fax 315-452-0160)

 **AUDIOARTS' ENGINEERING**

World Radio History

Index

WME PREVIEW

First World Media Expo Opens in LA by John Gatski	15
Numerous Companies Plan Exhibits	16
SBE Positive about WME by John Gatski	16
RAB Sessions Focus on Ads, Marketing by Wayne Cornils	19
Computers Aid Radio Journalists by Alan Haber	20
Technical Sessions from NAB by John Marino	20
Exhibits Packed with New Products by T. Carter Ross	22
No Shortage of PC-Based Radio Gear	30

FEATURES

Workbench by John Bisset	55
New Technology Means More Fun and Mischief by Al Peterson	56
Building and Using Loop Antennas by Chris Scott	58
Music Festival Are Good Radio Material by Bruce and Jenny Bartlett	60
Should Radio Drive the Info Highway? by Mel Lambert	62
Bring 286 Workhorses Back to Life by Richard Mertz	86
Keep on Top of Needed Documentation by Harold Hallikainen	88
Upgrade Old Dynacos with Van Alstine Kit by Doug Fern	90
Dealing with Cellular Re-radiators by Cris Alexander	94
Monaural Audio In, Stereo Audio Out by A.W. Edward	96

RUNNING RADIO

New Radio Formats Rooted in Past by Alex Zavistovich	65
Rules for Writing Creative Radio Spots by Ronald Pasha	66
Phone Blitz Can Pad Bottom Line by Bob Harris	69
Keep Your Employees Safe from Harassment by Sue Jones	70
Prague FM Takes to the City Streets by Charles Recknagel	72
Studio Primer for Satellite Radio by Karl Baehr	73
Cincinnati Boasts DAB AM Station by Judith Gross	76
Good, Scary Fun Is Key to Fall Promos by Mark Lapidus	77
Eavesdropping on Cars for Ratings by Dee McVicker	79
Mastering the Art of Cold-Calling Sales by Don Surath	82
Love of Radio Keeps DJ Coming Back by Alan Haber	84

► continued from previous page

Doctrine mandated stations to air all sides of a controversial issue. During the 1980s broadcasters pushed for the doctrine's repeal, arguing that it hinders public debate and seriously infringes on First Amendment rights.

To strengthen their argument, the four broadcasting organizations cited a decision by a federal appeals court last year and another FCC ruling three years ago which both upheld that the Fairness Doctrine repeal includes ballot issues.

"If the Commission were to okay this meritless request, it would make a mockery of its processes," NAB Associate General Counsel Steve Bookshester said.

UPI Picks up Noble Broadcasting Subscription

WASHINGTON The Noble Broadcasting Group recently signed a subscription contract with UPI, adding 10 more radio stations to UPI's subscriber base.

The move helps to strengthen the once beleaguered news service that has been under new ownership for the last two years. During this time, UPI has expanded its radio network and broadcast wire subscriptions, added a global satellite distribution network, and contracted to be the exclusive news-programming supplier to CBS Americas Spanish language radio network out of New York.

IDB Broadcast Woodstock '94 to the World

LOS ANGELES IDB provided satellite coverage of Woodstock '94 to radio and TV stations around the world.

IDB transmitted the first leg of Woodstock through an IDB flyaway satellite uplink system. Signals were then downlinked at IDB's Los Angeles and Staten Island, N.Y., international teleports for distribution.

IDB provided audio services to the Japanese Broadcasting Company (NHK) with the help of its digital 3D2 codec and IDB transmitted around-the-clock satellite feed to Europe via transponder space

on INTELSAT K.

The telecommunications company also transmitted Woodstock to South America on PanAmSat PAS1. IDB transmitted Woodstock to worldwide locations by using its network of transportable, flyaway and fixed uplink and downlink facilities.

New Radio Sales School Open in Los Angeles

LOS ANGELES The Southern California Broadcasters Association (SCBA) will start classes Oct. 4 for a new school it established to teach the basics of contemporary radio selling to radio sales staff in the Los Angeles area.

Tim Pohlman, the chair of the general sales manager council of the SCBA, said the school will provide additional training in an area of the radio industry "that has been traditionally light on training."

Marie Kordus, the general sales manager for KPWR(FM) in Los Angeles, believes the school is a necessary training tool for newcomers to radio sales.

"It's only fair to make sure they (newcomers) have a thorough grounding in the business in order to increase their chances of success and make them more productive," she said.

For information, call SCBA at 213-938-3100.

First Chicago Finances Radio Group Expansion

CHICAGO In two separate ventures, the First Chicago Equity Capital recently invested \$15 million for acquisition financing.

First Chicago Equity Capital invested \$5 million to help Midwestern regional radio group Central States Network, L.P., to acquire 7 radio stations, five in Wisconsin and two in Illinois.

Central States intends to acquire more radio stations in the future.

In another venture, First Chicago Equity invested approximately \$10 million to support the acquisition of Garrett Aviation Services, a Phoenix-based company that provides jet and airline maintenance. ☺

Continental Lands New China Contract

by John Gatski

DALLAS In a deal that underscores the importance of foreign markets for U.S. broadcast equipment companies, Continental has contracted with the People's Republic of China for \$11 million worth of transmitter business.

The 48-year old U.S. company, which has transmitters in 5,000 U.S. stations and in 100 countries around the globe, has committed to a series of contracts involving FM and shortwave transmitters that will be produced in Dallas and in factories in Beijing, China. The Chinese will be using transmitters ranging from 50 watt FM exciters to 50 kilowatt shortwave units.

"We're a bit pleased about it," said J.R. Faulkner, vice president of marketing for Continental. "They shopped all over the world for the best deal they could get."

Continental expects more contracts with China in the long-term, according to Faulkner. He said the relationship with China began in 1991 when the company built two stations there.

"In the next ten years, they (the Chinese government) estimate they will need 50,000 FM stations—most

of them under a kilowatt," Faulkner said. Within the next year, 300-400 transmitters will need to be produced, he added.

The current contract stipulates that transmitters will be built in the U.S. and in China. Faulkner said that the smaller FM transmitters will be based on Continental's solid state, 50-watt exciter, Model 802-B and built in China. Other transmitter types that will end up in China include the 500 kilowatt Model 420-C shortwave transmitter.

Faulkner said that a lot of lengthy negotiations were necessary to firm the contract, which ended a few months ago with China's minister of radio, film and television visiting Continental headquarters in Dallas.

Faulkner said the contract spells out typical arrangements, such as percentage of profits, costs and China's manufacturing equipment under Continental's license.

Logistically, there will be technical training for the Chinese workers, and U.S. workers will have to get used to working with the metric system for weights and measurements.

Continental has branched out its foreign involvements in the last few years. ☺

Basically excellent

We improved the specs and simplified features until we knew we had created the best bulletproof, no-frills, high-performance FM exciter at the most competitive possible price. As with all BEXT exciters and our full line of RF equipment, the new LEX 25 is backed by our two year warranty and 24-hour customer service hotline.

LEX 25
25 Watt FM Exciter
S/N: >80dB
THD: <0.03%
\$1,995



1045 10th Ave.
San Diego, CA 92101
619-239-8462
FAX: 619-239-8474

BEXT

Circle (72) On Reader Service Card

Speak Easy

with the
Comrex
Talk
Console™

Radio just took a big step forward with this Talk Radio Package. Easy to set up and easy to use anywhere, it includes everything needed to put callers on the air.

It conferences one or two phone lines with two microphone channels for host and guest. The second mic channel will also accept inputs like CDs or tape decks.

"CUE" lets you talk with the caller off air.

"HOLD" puts callers on hold and feeds program back to them. Integral mix-minus circuitry insures that callers won't hear their own echo when on air.

The Comrex Talk Console for:

- Syndicated Talk Programs
- Radio Features Production
- Remote Talk Show Broadcasts
- Newsroom Interviews



A sophisticated solution in a simple package.

COMREX

Comrex Corporation
65 Nonset Path, Acton, MA 01720
800-237-1776 In MA 508-263-1800
Fax 508-635-0401

Comrex (UK) Ltd.
75 The Grove, Ealing
London W5 5LL, UK
081-579-9143 Fax 081-840-0018

Circle (117) On Reader Service Card

See Us At WME Booth 2128

Making Way for the Really Fun Part

WASHINGTON Longevity is an elusive quality in radio. The average consumer is ready to switch radio channels at the hint of a note from a song they don't want to hear or an ad they've grown weary of. Radio formats come and go. Since the early '80s, radio ownership,

been selling CBS Radio since 1960.

Jerry Vernon is the oldest active employee at CBS, who in addition to working full-time, body surfs, sails and plays golf.

It is no surprise that, staffed with employees like that, CBS is one of radio's cornerstone companies, around since the begin-

L to R: Peter Lund, president, CBS Television Network; Nancy Widmann, president, CBS Radio division; Jerry Vernon; Gene Jankowski, former president CBS/Broadcast Group; and Robert Kipperman, vice president and general manager, CBS Radio Networks.



too, is less stable; stations are bought and sold like shares on the stock exchange.

Yet many in this business have enjoyed long and profitable careers. Many radio companies have enjoyed long and astonishingly good runs as well.

Every time I visit a successful radio station, the manager or owner always says to me that the secret of success is working with good people. And of course, they are right.

The accolades are even nicer though, when the whole company is brought in on the celebration of a good employee. CBS Radio threw a surprise birthday party for Jerry (Gerald) Vernon on August 25 for his 80th birthday (see photo). The company invited clients, media executives and present and former colleagues. You can well imagine how long the list must have been—Jerry has

ning, and still moving forward.

It takes more than great people though, to achieve and sustain greatness.

There also has to be a driving vision, an idea of where the company should be going and how it is going to get there. And in spite of its old age (relatively speaking) our recent front page story on USA Digital's progress suggests that CBS is still in front, along with other venerable giants like Westinghouse and Gannett, blazing new trails with in-band, on-channel digital audio radio.

For the radio business, this is good news. For CBS, it reflects a driving vision that is shaping the company internally as well as externally. CBS Radio recently unveiled its newly renovated

Washington bureau (RW, July 12). The operation features several of Corporate Computer Systems' P.A.C.E. (Personal Audio Computer Editing) workstations, in nifty little modular rooms called snowflakes (no two are alike).

Each PACE system emulates a radio production studio and contains icons representing the familiar old tools of the trade, i.e., tape recorders, a mixer, tape duplicator, master tapes and cartridge tapes and a television screen.

Each reporter has the ability to record audio from a variety of sources simultaneously, archive materials for future use and digitally edit complete reports from intro to outro, including multiple actualities.

But I think the more important issue here is one which radio, as an industry, will increasingly face. I'm talking about the impact computers are having on the way everyone does business.

A cursory look at the growth of computer-based systems in just the last few years makes it obvious that we are definitely on the fast track to somewhere, and the vehicle of choice is a digitally-controlled one.

CBS's Tony Masiello, vice president of technical operations (and part of the USA Digital story) has a vision. In conjunction with CCS's Tim Chase, he has contributed to radio's future right here on M Street.

The battle for software development and the integration of new digital services into the hardware and daily routine of radio has happened before, and manufacturers everywhere have proven themselves capable of navigating through cyberspace at a comfortable clip. But CBS Radio's Washington News bureau has gone one step further. Instead of the people disappearing, the computer has made them more valuable employees.

Innovation based on the real need of a radio customer is now making it easier to broadcast high-quality programming with significant long-term savings. If a PACE were to have a problem, the replacement part is merely a computer part—available anywhere and everywhere, in whatever

price range you want to buy.

That is not to say that whatever is being manipulated doesn't matter. I think, rather, it means that you now have more time to focus on the product, without worrying about the limitations of the delivery system.



John Casey has joined Denon Electronics as marketing manager for all of the company's product lines. Michael Gatto has been named car audio sales manager.



John Casey

Most recently, Casey was the sales engineer for RE America's new products division, a position that allowed him to focus on the development of RDS broadcast and digital audio/video products. As a member of the National Radio Systems Committee (NRSC) for the last three years, he played an important role in the formation and adoption of a standard for the Radio Broadcast Data Standard (RBDS). He has worked closely with Denon and industry associations to educate the public about the benefits of RDS Smart Radio products.

Gatto was district sales manager for Pioneer Electronics, U.S.A. car electronic division.



Get on the right track...

Unattended operation helps you operate your station profitably. All it takes is a satellite or automation program source, a good transmitter control system, and a way to handle EBS.

You take care of the program source... We'll help with the rest.

A transmitter control system from Burk Technology relieves you of the need to keep someone at the station just to take transmitter readings. Add our exclusive Studio I/O and we'll run EBS for you, too.

Burk gives you the flexibility to run your station the way you want, and in full compliance with FCC rules.

Call us now. We'll show you a new way to run a railroad.

TOLL FREE 1-800 255-8090

BURK
TECHNOLOGY

7 Lomar Drive, Pepperell, MA, 01463 (508) 433-8877

READERS FORUM

If you have comments for Radio World, call us at 800-336-3045 or send a letter to Readers Forum (Radio World, Box 1214, Falls Church, VA 22041 or MCI Mailbox #302-7776). All letters received become the property of Radio World, to be used at our discretion and as space permits.

Digital's defenders

Dear RW,

I really feel the need to answer the "Not Ready for Digital" letter in your August 24th issue. When I was reading the reliability questions of digital systems, I was reminded of the story of the commuter who knew his car would break down, so he always had his horse running alongside just in case.

Yes, I know that sounds a little ridiculous, but it is just as ridiculous to portray PC technology as being less reliable than the old analog stuff that's been around since before most of us can remember.

Media Touch Systems was just about the first company to introduce PC studio control PCs at some locations have been operating for years and generally maintenance free. Today's hard drives are rated at 150,000 hours mean time between failures. That's over 15 years! I'd like to hear what a cart machine would sound like after 15 years without maintenance.

Oh yes, that brings me to cost justification issues. It is sometimes very difficult to come up with cost justification guidelines that pertain to every radio station. Everyone is different. But, if you look at costs other than just tape replacement, then you start to see where true comparisons and savings can be achieved.

Add up the number of man-hours in maintenance time alone. What about the time spent walking carts around your station or looking for carts when they get lost. And what about the space taken up by either walls of or racks of tape carts.

Let's take the whole issue a bit further. Any digital system worth its salt gives you the ability to take in a traffic and perhaps a music scheduling feed. That's right. All this is done electronically. How many times does the worker in the front office walk back to the studio to add or

delete spots? Now she can just sit at a workstation and make those changes. She and the jock can now get rid of half an hour of gab time.

Did anyone every stop to think about accurate electronically produced "as run logs"? The proof is in the PC database that a particular event played as it was supposed to or not. This saves a whole bunch of time by not having to look over every page of every log.

One of the big issues in favor of compact digital systems is on-air efficiency. The August 24th letter asked if a hard disk storage system would increase profits or listeners. His answer was for major markets: "I cannot see how."

Mr. Alford, here's how. In most major markets, the talent goes into a studio, gets the log and starts pulling carts or pre-stacking his show. Along with spots, promos, etc., this could include pulling out CDs or music on cart. The talent spends a considerable amount of time preparing to go on and then during the show spend a lot of time keeping up with the pre-stacking. Oh yes, in some major market stations, the talent doesn't do this activity, but rather a technician or producer.

Gee, if the operation is combo, your talent might finally have time to think about their on-air performance, and if the operation is not combo, *voila!* There might be a chance to reduce costs and "increase profits."

Mr. Alford, someday is really here, and stations all over the country are proving it. In general, however, I challenge you to think of one industry which is in the forefront of modern life that is as technically backward as radio.

Jim Waterman
Director of Sales
Media Touch Systems
Salem, NH

Dear RW,

In reply to "Not Ready for Digital" in the August 24th "Reader's Forum" by Kelly D. Alford of KJR-AM-FM in Seattle, I totally disagree with all aspects of his thinking on converting to digital audio storage. Having been in the sound recording business for over 27 years, I've watched and listened to the evolution of digital audio from its infancy, and what a long way it has come. The sound obtained with current technology runs circles, big circles, around anything in the analog recording world.

When I built WMOO back in 1991, I was faced with the choice of using conventional "cart" technology or building a state-of-the-art (tapeless) facility. I consider MOO-92 to be the most technically sophisticated radio station in the state of Vermont. Technically there is absolutely no comparison between digital audio storage and a cart that runs at 7 1/2 IPS with three tracks on 1/4-inch tape. No longer do we have to deal with poor frequency response, lousy signal-to-noise ratio, wow and flutter, phase alignments, distortion, tones for start-top, dirty capstans, pressure rollers, cart pressure pads, plastic this and plastic that, endless loops and the infamous once-around splice. With

Keep Radio on Top

The upcoming supershow, World Media Expo (WME), already has changed the character of the fall NAB Radio Show, and it hasn't even happened yet. Much of the change is positive, but not all.

At press time, the radio/audio pavilion at WME boasted more exhibitors than ever before, making for a record-breaking Radio Show topping last year's Dallas gathering by

roughly 25 percent. The NAB reports that registration for the Radio Show is up as well.

Equipment manufacturers should be pleased. Where they once had to attend four different conferences (or at least three for those that are radio-only), they now handle all four with one trip. SMPTE, SBE and RTNDA are in the "supershow" mix and bring with them their attendant members.

But in this success lurks a trap for NAB. Much of the growth and momentum of the association's spring show is clearly headed in the professional video direction. Fewer and fewer radio station managers and engineers are attending the spring gathering—opting instead for the fall show, which has been more attractive in that it has been an all-radio event.

The year's NAB Radio Show, even with its record-breaking radio/audio pavilion exhibit, already has been dwarfed by television at WME. The combined exhibit floor boasts 230 video companies to radio's 221, occupying 75,800 square feet of exhibit space to radio's 53,400 square feet. Radio attendees will also undoubtedly be in the minority.

For radio broadcasters concerned about the WME version of the NAB Radio Show, numbers like that make them nervous. In the spring show, more and more radio equipment companies are opting to locate their booths on the video side of the convention center. These companies are drawn by the bustling traffic in the video hall compared to the audio/radio hall. Could this trend repeat itself at future WMEs?

It's clear that NAB and the other co-organizers, SBE, SMPTE and RTNDA are sensitive to issues like this by the way they have structured the WME. But, speaking for radio, NAB needs to make sure that the Radio Show remains distinct and separate in future WMEs. If NAB does not continue to provide the radio industry with its own strong forum, someone else may.

—RW

Radio World

Vol. 18, No. 19

September 21, 1994

Editor-in-Chief.....Lucia Cobo
Managing Editor.....John Gatski
Associate Editor (News).....Thomas Pear
Associate Editor.....T. Carter Ross
Contributors.....Frank Beacham/N.Y.
Bruce Ingram, Pamela Watkins, Nancy Reist
Technical Editor.....John Bisset
Technical Advisor.....Tom McGinley
Editor (International).....Alan Carter
Editor (Radio World Magazine).....Charles Taylor
Editorial Assistant.....Whitney Pinion



Radio World (ISSN: 0274-8541) is published bi-weekly by Industrial Marketing Advisory Services, Inc., 5827 Columbia Pike, Suite 310, Falls Church, VA 22041. Phone: 703-998-7600, Fax: 703-998-2966. Second-class postage rates are paid at Falls Church VA 22046 and additional mailing offices. POSTMASTER: Send 3579 forms and address changes to Radio World, P.O. Box 1214, Falls Church VA 22041. Copyright 1994 by Industrial Marketing Advisory Services, Inc. All rights reserved.

—PRINTED IN THE USA—

**Next Issue of
Radio World
October 5, 1994**

digital storage media, you don't ever think about this nonsense. The only analog recorder we have is a reel-to-reel for transferring agency or outside tapes. For editing we use a digital PC-based workstation.

Quality? Does it make a difference to our listeners (and let's not forget our advertisers)? It sure does. Clean, unadulterated sound, always technically correct. Ever heard a misaligned cart playing back on your bedside clock radio swishing in and out? Awful! There are still stations that transfer music from CDs to cart. That one I'll never understand. Nowadays the listener does notice the difference. He or she is a lot hipper than you think.

Cost effective? You better believe it is. Have you checked the price of a cart machine lately? Prices range from \$1,800 to \$4,800 for a single decent machine, plus the costs for the cart itself. An average small market station needs at least four or five machines; that adds up to big bucks. Recently I have seen entry-level digital systems on the market starting at \$6,000 which would replace an infinite amount of cart machines. Six grand versus \$4,800 x four or more machines? Cost effective? You bet. Reliability? Let's face it, everything breaks sometime, somehow. I worry about that, but all-digital storage systems are built around sophisticated computer hardware with SCSI hard drives that have MTBF ratings near the 100,000 hour range. That's more than

10 years. I would love to see what condition a cart machine would be in after 100,000 hours, not to mention what it would cost to maintain it.

Here at WMOO we maintain a complete backup (on R-DAT digital tape) of everything that is stored on the digital system just in case. Most of the current systems have a "mirror" option where the digital signal is recorded simultaneously onto two hard drives. The only problem WMOO has had with our digital system since we went on the air in 1991 was a bad PC type power supply that was easily replaced.

Automation? It's so simple with computer automation. I can't even imagine having five or six racks full of mechanical nightmares. Carousels, carts, switchers and whatever. I wouldn't be able to sleep at night. With computer technology, automation, no matter what your format is, is a piece of cake. Just check the classified section of **Radio World** under "automation equipment" for a listing of all the clunker systems that modern digital technology has probably replaced.

In 1994, we owe it to our listeners, our advertisers and ourselves to provide the latest in technology. Remember, guys, we've got a lot of competition out there so we had better sound our best.

Thomas S. Steele
President and Chief Engineer
WMOO(FM)
Derby, VT

The only stereo switcher,
audio mixer,
utility dubbing center,
voice-over recording system
and compact production facility
in a single rack space...



FAST TRAC II™

By Henry Engineering

The Henry Engineering Fast Trac II can provide the basis for an efficient audio dubbing/production center requiring much less space and expense than a conventional production studio. It allows you to select one of 6 stereo line level inputs, mix it with a mic level input utilizing manual mic level control or automatic "ducking" for great sounding voice-overs. With Fast Trac II's auto-start machine control you can create perfectly cued dubs automatically, with a push of a button. Additional features such as two individual, selectable processor loops, 3 modes of mono plus stereo outputs, comprehensive monitoring, input balance control, even a phase scope output make the Fast Trac II one extremely useful piece of equipment.

**For Pricing And Information On Henry Engineering Products
Call Or Fax Toll Free:**

Phone: 800 • 426 • 8434

Fax: 800 • 231 • 7055

Equipment Solutions To Keep You Number One

BSW
BROADCAST SUPPLY WORLDWIDE

7012 27th Street West Tacoma, Washington 98466

Circle (30) On Reader Service Card

INTERNATIONAL UPDATE

Canadian L-Band DAB Testing Still On-Going

by James Careless

MONTREAL On top of the Canadian Broadcasting Corp. (CBC) radio-TV transmitter building, high on the slopes of Mount Royal overlooking the city, stands a small antenna that could revolutionize broadcasting.

The structure is much more than just an L-band antenna for a 200 W DAB transmitter (1.5 kW ERP). It is the anchor of a single frequency network (SFN) being tested in Montreal by Digital Radio Research Inc. (DRRI), the public/private broadcaster consortium currently spearheading DAB research in Canada, with support from the government. The project utilizes Eureka-147 technology.

"We're building part of a station that will replace the Class C coverage of an FM station in Montreal," explained CBC engineer Michel Fortin during a recent tour of the site.

"To do that, we expect we will need five sites. In this experiment, we're building three sites that will cover about 60 percent of what FM covers at a lower cost than FM."

Heart of the system

The heart of the SFN system, including computer control and COFDM encoding equipment, is housed in a single rack within the Mount Royal transmitter room.

The other two repeater transmitter sites are located at Lac Echo to the north (42 W ERP), and Rigaud to the west (130 W ERP), with an average separation between them of 33 miles.

All three broadcast the same third-generation Eureka-147 signal on 1468.75 MHz, operating primarily in Mode II with a guard interval of 62 microseconds. Guard interval is the separation between the transmission of the signal symbols.

The goal here is to create a DAB broadcasting signal environment where the

problems involved with synchronizing and optimizing an SFN—notably destructive interference—can be experienced and dealt with.

The choice of Montreal by DRRI as a test site was no accident. The presence of Mount Royal right in the middle of the city—standing 761 feet at its peak—cre-

The heart of the SFN system is housed in a single-rack transmitter room.

ates coverage gaps in some areas. This is the problem that Eureka "gap filler" technology, which operates on the same principle as the SFN, is designed to address.

To achieve this end, engineers like Fortin have paid close attention to the problem of signal timing within the coverage area, for this lies at the very heart of the SFN challenge.

The challenge is this: If signals from the three transmitting antennas arrive at the Eureka-147 receiver within a 62 microsecond window of synchronization, the result will be six channels of CD-quality stereophonic audio (two CBC and four private radio signals). However, if the delay in synchronization exceeds 62 microseconds, destructive interference will occur, and the audio will be impaired.

It takes time

Unfortunately, it takes time to relay the six channels of audio from the Mount Royal site to the two repeater sites and then get those signals on-air; 200 to 300 microseconds, to be exact.

That is why after the source program is encoded and before it is modulated, Fortin

explained, it is split into two parts. "We divide it between two RF modulators," he said, "and they have built-in delays."

"So what we do with the Montreal signal, before it's fed to the amplifier, is to delay it 200 to 300 microseconds, which corresponds to the delay in the microwave link to Rigaud or Lac Echo."

The result is that all three sites transmit the same signal toward the middle of the SFN, Fortin said. "When you get in the middle, all three stations are coincident."

In practice, this form of SFN works, according to the measurements recorded using a van-mounted Eureka receiver. However, it does not always work perfectly.

"The most difficult thing we found at SFN is we were using typical antennas for L-band, not really fancy patterns or anything," Fortin said. "And we found out that at one point you get close to a station, and the remote one will hit the receiver outside the guard interval because you're getting high, and you're getting a line of sight to the far transmitter."

The problem is that the SFN signals are optimized for synchronization in the center of the coverage; at the fringes, if the overlap is too big, they are sufficiently out of sync to cause destructive interference.

The cure

The cure has been to tilt the transmit antennas, to focus transmission power near the local transmitter site and to limit the far field coverage to the beginning of the guard interval zone. To date, this has solved most of the overlap problem, Fortin said.

A similar problem was experienced during tests near Mount Royal, when the receiving vehicle was located on the far side of the mountain—in line of site of a far transmitter, but with the local transmitter antenna caught in the mountain's "shadow."

According to Fortin, the solution here is to install additional antennas that will increase the field around the mountain, substantially boosting the ratio of wanted to unwanted signal, so that the Eureka receiver can ignore the remote transmissions. "You have no audio cutoff," Fortin said. "But this is just field experience. It's pretty hard to predict."

There is a final challenge that also must be addressed, and it cannot be dealt with by the Montreal three-station test site. The problem is simply that, as you add more transmitters to an SFN, you add more variables. "More synchronizations, more distribution, more timing," Fortin said.

In terms of testing the SFN concept in Montreal, planners know it works with three. "We are currently doing measurements to determine how well it works, and we think it might work with more," Fortin said. Obviously, this question can be answered only by someone installing a four-or-more transmitter SFN system.

In the meantime, research continues at the Montreal DAB, not just on SFN, but also coverage extension, feeding over the air the Lac Echo and Rigaud transmitters from the Mount Royal site and rebroadcasting the signal outward. ☺

Question:
Ever wonder why transmitter manufacturers operate Altronic dummy loads at NAB and other trade shows?



Answer:
The best performance and the most dependable dummy loads built.



ALTRONIC RESEARCH INC.

WATER AND AIR COOLED
MODELS FROM
1000 WATTS TO 1,500,000 WATTS

P.O. Box 249
Yellville, AR 72687
(501) 449-4093

Audio DA's for a BROAD RANGE of applications

- For every requirement and every budget.
- Single rack units to 4 in by 16 out.
- Modular mix and match to 10 in by 60 out.
- Multiple mic and line amplifiers, 4 to 8 channels.
- Transformer and active balanced outputs to +30dBm

ATI AUDIO TECHNOLOGIES INCORPORATED

CALL OR WRITE NOW FOR FREE DETAILED BROCHURE.
328 Maple Ave. Horsham, PA 19044, USA (215) 443-0330 FAX: (215) 443-0394

If We Don't Have It You Don't Need It.

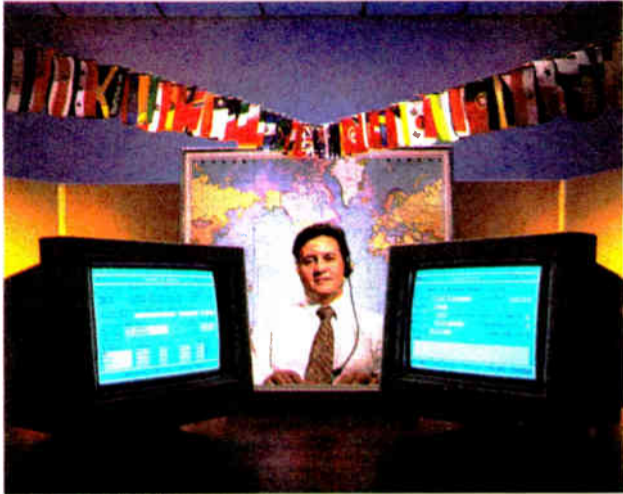

Serving broadcasters on six continents and in more than 100 countries, we have become the world's leading distributor of studio, production, and satellite equipment, offering the widest range of radio products from a single source.



We deliver when you need it. Over 90% of our orders are shipped within 24 hours. Computer technologies and experience in transportation management, packaging and rate negotiations has resulted in the most efficient shipping and receiving department unsurpassed by our competition.

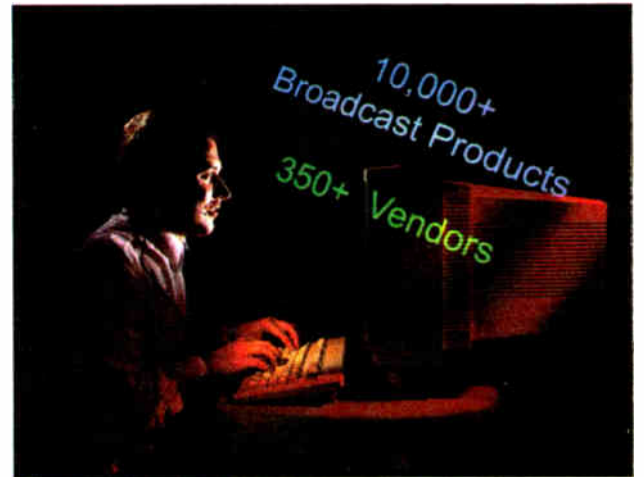

Our experienced broadcast professionals are working when you are—Monday through Friday, 8:00 a.m. to 8:00 p.m. Eastern. When you know what you need, you'll get the right price. When you don't, you'll get experienced advice.



Satellite products we distribute include reception equipment for digital or analog SCPC, audio or video subcarrier data, uplink and downlink antennas and support products. We are your primary source for the most innovative and effective technology.



With today's growing shortage of broadcast engineers, many broadcasters lack the technical staff to evaluate, maintain and service their equipment. We provide unparalleled customer support with experienced, certified service technicians.



Customer satisfaction is number one. Customer service representatives are ready to check your orders and answer any questions you might have. You can always count on fast, friendly service.

 **HARRIS
ALLIED**

1-800-622-0022

NPR Personnel Enjoy New Facility

► continued from page 1

each week to its diverse library of news and cultural programming. The new, acoustically improved facilities, which include seven full control room/studio combinations, and several other control rooms without accompanying studio space, reside on three floors of the new building.

The Russ Berger Design Group of Dallas, Texas was responsible for the facility's acoustic design; NPR's architectural firm (and electrical and mechanical engineers) Burt Hill Kosar Rittelmann Associates, of Washington, D.C., and Pittsburgh and Butler, PA, worked on the building's interior design; and Harris Allied Systems of Florence, Kentucky worked with NPR on systems design and technical installation.

It is hoped that the new facilities will become a resource for all of public radio.

—Donald Lockett
VP of audio engineering, NPR

The second and third floors of 635 Massachusetts Avenue are designated as news floors. Four of the building's seven control room/studio combos are located on the second floor, including studio 2A, from which the weekday and weekend editions of "All Things Considered" and "Morning Edition" are broadcast.

Computer terminals, installed beneath the studio's broadcast table, are visible through glass ports to cut down on noise and reflection, (though program hosts still seem to prefer reading from paper).

Three of the four control room/studio combos on the second floor are production-oriented; one of the control rooms is actually flanked by two studios, which allows rapid-fire change from one interview to another (this studio, 2C, is also used to send the second and third feeds of "All Things Considered" and "Morning Edition," and any live updates that need to be included during re-feeds). Pacific Recorders and Engineers consoles are used in all of the studios on the second floor.

On the third floor, "Talk of the Nation," launched in 1991 as an outgrowth of NPR's call-in programs broadcast during the Gulf War and Soviet coup, emanates from studio 3A, which also functions as a backup to studio 2A and as a production studio. Equipment used here includes a flexible, new Pacific Recorders and Engineers STX series 34-slot frame broadcast console; MCI reel-to-reel tape recorders; two CD players for incorporating production music into programs and a versatile IFB system. Sophisticated IFB systems from Sierra Audio Systems are also in use in studios 2A, 2B, 2C, 2D, 4B and 4D, as well as in the three news Record Centrals. Studios 2A and 3A, which, like the other studios in the building are extremely quiet, feature full call-in systems, and are large enough to accommodate multiple hosts and guests. Each has separate announce booths for the origination of live newscasts.

Performance

Two more new studios are located on the fourth floor, dubbed "the performance floor." Studio 4A, a large, double-height 3,500 square-foot recording studio, also known as NPR's Advanced Audio

Facility, features a spacious control room and an isolation booth. Equipment used here includes a fully automated Solid State Logic SL 4048 G+ recording console which can accommodate 40 inputs and 32 outputs; Genelec nearfield monitors; and prototype JBL main monitors. This facility is the first of its kind for NPR; although space was set aside at M Street for a recording studio, it was never built.

Next door, a double-height broadcast studio, 4B, which is a little larger than the comparable studio that was in use at M Street, is outfitted with a Sony 2036 broadcast console, multiple two-track tape machines (Dolby SR noise reduction is used extensively on analog tape recorders in the performance production areas), and full IFB.

Studio 4B supports live broadcasts, such as the daily program "Performance Today," and functions as a recording site for performances by small chamber groups and solo pianists. Masonry walls and the ceiling are acoustically treated with fiberglass.

The fourth floor was designed with expansion in mind. Space is set aside here for an eighth control room/studio combination to be implemented only when programming needs warrant.

Two multichannel Sonic Solutions digital audio workstations are now in use on the fourth floor. One is outfitted with No-Noise) to remove rumble, hiss, hum, crackle and other noise from existing recordings, and the other is a workstation without No-Noise on which mixing and signal processing can be done. A third multichannel Sonic Solutions workstation will be used by performance producers for editing and transfers.

Equipment

Much of the equipment used at M Street, including all the tape machines (Sculleys and MCIs) and most of the processing gear, from equalizers and compressors to limiters and filter sets, was brought over to the new building. Studer and MCI tape machines are used primarily for editing, and Sculley players are used strictly for editing. All but two of the consoles are new.

Jan Philip Andrews, project engineer for NPR's Audio Engineering Division, who supervised much of the move and installation of equipment, said that the new building, which NPR plans to inhabit for about 15-20 years, is much more flexible than the old building, thanks in part to substantial signal routing availability.

In addition, he said that, because the new consoles are so flexible, control room operations are more efficient. For example, more outside sources can now be simultaneously incorporated into programs.

Analog infrastructure

The decision was made to basically go with an analog infrastructure at 635 Massachusetts Avenue. "We feel that analog is a medium that we're going to have to endure for some time yet," he said, adding that the cost of converting to digital would be prohibitive. "There's...no affordable system...that would support the number of people that need to be able to massage the audio at this point. So, we're stuck with quarter-inch," he added.

Digital is present in the building, howev-

er; both T1 and ISDN, and to a lesser extent Switched 56, are used to get production materials into and out of NPR. In addition, Sony R-DAT recorders are used throughout the building.

Andrews said that the building was designed to be "the last great analog facility," however, it is equipped with a cable housing and rack structure, and ample power and air conditioning to support a conversion to digital. Andrews said that NPR will have to move to a digital structure at some point. "Technology will evolve, and we'll have to do things differently," he said.

The routing system

The new, more substantial BTS routing switcher system is substantially larger than the switchboard-like system used at M Street. The new system features four routing switcher matrices, two which reside in the System Technical Center (STC) — a 256 x 160 single channel matrix, and a 64 x 64 AES/EBU digital matrix. The Master Control matrix has three levels of audio — two stereo levels with 128 x 128 cross-points, and a 192 x 160 mono level.

Finally, stereo matrices of 96 x 64 are located in the equipment area common to the three news Record Centrals on the second floor. Each studio in the building has at least four links to the switching system, so audio can be taken from satellite and ISDN lines, among other sources.

There are two stand-alone control rooms



Studio 4A is one of 15 control room and studio suites. The room can handle a 40-piece orchestra, jazz band, or radio drama with a studio audience.

on the fourth floor of the building, one of which is used for refeeds and is limited to nearfield monitoring, using Genelec 1031A speakers; the other is used primarily for preproduction for performance programs.

Three Record Centrals on the second floor support NPR's news operation by allowing two or three events to be monitored and controlled simultaneously; Pacific Recorders and Engineers consoles are used in each. Small areas both inside and outside each of the three news Record Centrals are used by reporters to monitor and dub off audio from portable cassette or DAT players to reel-to-reel or other formats. A common equipment area houses eight reel-to-reel tape recorders which record long-term feeds, such as House hearings and Pentagon briefings from Washington Area News Distribution (WAND).

Andrews said he often refers to the

Record Centrals as "short order kitchens for audio, because, basically, you're flipping burgers and omelets and lots of things simultaneously."

Incoming audio from NPR's various facilities and sources arrives in Master Control on the sixth floor. There, audio is switched and distributed to other facilities within the building. ADC patch bays, which wrap around the routing switcher, are erected in racks as a fail-safe measure against switcher failure. The automation system is located here; the stereo and mono switchers are located in the adjacent equipment room, as are a bank of FM modulators. FM signals are available throughout the building, so staff can listen at their desks without having to tie up any technical facilities.

Archive copies of broadcast programs are recorded here on Studer reel-to-reel tape recorders. Sony PCM-7030 DAT recorders are used to record and replay refeeds for member stations that wish to air later versions of NPR programs (these feeds are used by many East Coast stations).

NPR's System Technical Center, located next door to Master Control, is the hub which controls all traffic on 12 wideband, FM-quality channels (to be increased to 24) on the Hughes Galaxy IV satellite to member stations throughout the country. Currently working through an analog system, a switch to a digital ComStream system is expected to take place within the next year and a half.

The building also is blessed with an abundance of edit booths—21 to be exact. Andrews said they were designed to be upscale, acoustically speaking, "because we see digital audio workstations of some

sort migrating to those rooms over time." Seventeen of the edit booths are used by news staff; four are used by performance staff. Each contains a computer terminal accessible to the Newspro electronic newsroom system, and a stand-alone reel-to-reel tape recorder with its own speakers.

Uniquely positioned

In a recent issue of NPR's "Engineering Update," Donald R. Lockett, vice president of audio engineering, said that "NPR is now uniquely positioned to take advantage of today's broadcast technology and grow for the future. It is hoped that the new facilities will become a resource for all of public radio and provide programs that increase the listenership both nationally and internationally."

The grand infrastructure of 635 Massachusetts Avenue hints that NPR is well on its way to reaching this estimable goal. 

Lost In The Maze Of Hard Disk Systems?

Head Straight to DCS

"Low Ball" Pricing

Costly Upgrades

Networking Headaches

Satellite Obstacles

Software Crashes

Limited Channels

Unproven Company

Customer Support Hassles

Sometimes, success in radio means taking chances... but not when it comes to a hard disk system. Radio stations have trusted Computer Concepts for 20 years. Our DCS system's unmatched track record at hundreds of stations worldwide is your assurance of success.

NOW, DCS MOVES EVEN FURTHER AHEAD!

See the newest features at World Media Expo/NAB Radio Show booth 2500

- Audio Central Plus - DCS now offers distributed and central database storage.
- Input source select - DCS now can accommodate additional recording input sources, including AES/EBU digital protocol.
- Optional removable hard drive - with an additional cart catalog.
- Audio file playback while DCS is still recording - particularly useful for time-shifting if one satellite feed runs into the beginning of another.

Also new at the Radio Show from Computer Concepts — V.T., the new, easy-to-use Windows™-based Visual traffic system. Don't miss it!

Circle (162) On Reader Service Card

DCS by Computer Concepts
CORPORATION

Computer Concepts Corporation
8375 Melrose Drive, Lenexa, KS 66214
Phone: (913) 541-0900 Fax: (913) 541-0169

INTERNATIONAL UPDATE

Shortwave Competition Is Fierce

by James Wood

BERKSHIRE, England International broadcasting in the high frequency spectrum began in the early 1930s in Great Britain, Germany, Italy and the Soviet Union.

In most instances, programming was simple. Britain, for example, originally broadcast only in English to the dominion countries of its empire. In 1937, a second language, Arabic, was added to counter the rising threat from Italy, which was broadcasting Arabic programs into Middle East regions, an area where Britain had powerful interests.

That date may be regarded as the initiation of a propaganda war with two players. By the end of World War II, Britain was the world's largest propaganda

broadcaster with 850 program hours a week in 46 different languages. This total was more than the total output from both the U.S. and the former U.S.S.R.

By the mid-1950s, 31 nations were involved in international SW broadcasting and by 1990, the figure had risen to more than 150. Compared to the 1930s when the HF spectrum was uncluttered, when man-made noise was not a problem and when 20 kilowatt carrier power was capable of clearly reaching the other side of the world, by the late 1980s, congestion had caused a spiralling in transmitter carrier powers. There now are more than 200 500 kilowatt SW transmitters in service, with more scheduled.

Today, shortwave broadcasting in the HF band from 5.9 to 26.1 MHz is used as a foreign policy instrument by governments;

broadcasting authorities are the licensees. Shortwave broadcasting as a foreign policy tool is nevertheless highly competitive as each nation seeks to extend its influence.

Foreign policy instrument

With the end of the Cold War, even Western-aligned broadcasters like VOA and the BBC now compete for the same listening audience in different parts of the world.

Though all international broadcasters have regular listeners on the shortwaves, many others tune to the loudest signal in a broadcast band, thus a competitive element is introduced. As a result, the incentive is 'with broadcasting authorities, governments and ministries of foreign affairs to make continued investments in transmission

systems and stations aimed at increasing audibility on the shortwaves.

Wars act as a spur to technology and the Cold War, which extended from 1948 to 1990, was no exception. The former U.S.S.R. honed techniques for sophisticated jamming of SW broadcasts from the West, which called for a prodigious effort both in manpower and transmitters, while at the same time operating a massive network of high power transmitters in all AM wavebands.

The Voice of Moscow radio consistently outperformed western broadcasters like VOA, BBC World Service and Deutsche Welle. The West, for its part, sought to maximize signal penetration into the former U.S.S.R. and Soviet-controlled countries in Eastern Europe with techniques like barrage broadcasting, and by broadcasting special programs in many different languages.

Radio Free Europe and Radio Liberty were particularly successful because broadcasts from these two organizations were targeted to specific countries. RFE, for instance, broadcast in Bulgarian, Czech, Slovak, Hungarian, Polish, Romanian, Latvian, Lithuanian and Estonian.

□□□

More information on international broadcasting and the insights of James Wood, a consulting engineer in broadcast transmission and regular columnist for Radio World, is available from his book "History of International Broadcasting" from the Institution of Electrical Engineers at phone: 908-562-5553; or circle Reader Service 190.

OSHA RFR Regulations

► continued from page 1

the Kentucky Attorney General's Office. The attorneys questioned whether the lockout/tagout program applied to RF radiation, according to Scott. They argued that the OSHA law was more applicable to general manufacturing where it is possible that an untrained person could access equipment and inadvertently adjust it so that could emit energy that could injure someone.

However, Scott said, the OSHA citations were upheld—except for a small violation that the RF radiation tagout sign was not in accordance with the OSHA specification. That citation was reversed. The fines were later adjusted downward.

Not well known

Scott said that since that time he has tried to alert stations about the potential for being cited and said that industry groups such as NAB are not even aware of it.

Some FCC personnel have become aware of the rule through isolated cases of stations not turning down power for

maintenance, but they said that OSHA has not done a good job of getting the word out.

"A lot of stations don't even know about it, said Jerry Ulcek, of the FCC's Office of Engineering Technology. The FCC refers many RF cases to OSHA, especially those regarding tower climbers.

Bob Curtis, an OSHA investigator from the Salt Lake City office, said that OSHA has not targeted broadcasters for educational updates on the regulations.

"It does not surprise me that they are not aware of it," Curtis said. "The standard is so broad (in its application to many industries). They (OSHA) have not done a separate listing for broadcasters."

Curtis said that it should be "common sense" for stations to already have formal procedures for protecting tower workers from excessive RF radiation. He added that OSHA is limited in its budget to target every one of the of large number of industries for regulation education.

"The trade associations (NAB, SBE) and trade journals are the best shot you have" for education, he added.

Although broadcasters are required to meet the OSHA guidelines, regular inspections of radio stations are unlikely, according to Curtis. "Most of these (investigations) are complaint driven," he said. Many are referred by the FCC. These complaints include what Curtis calls "a regular practice" of not powering down transmitters when workers are on the tower.

Stations can be fined up to \$7,000 per infraction by OSHA and such violations are now considered in FCC license applications and renewals, Curtis said.

The old way to set up an FM station.

Audio Processor \$2,000.00

+

Stereo Generator \$1,200.00

+

20 Watt Exciter \$2,400.00

+

100 Watt RF Amp \$2,900.00

\$8,500.00

For more information on our complete line of integrated transmission systems, contact us at: Phone 219-294-8050 Fax 219-294-8329.



Crown's integrated solution.

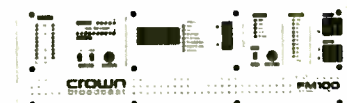

FM100 Transmission System

The FM100 Contains:
Audio Compressor
Audio Limiter
Stereo Generator
Exciter
100 Watt Amplifier
Low Pass Filter

Plus:
Remote Control I/O
And Much More...

\$5,695.00*

*Manufacturer's Suggested Retail Price



A Division of Crown International, Inc.
1718 W. Mishawaka Road
Elkhart, Indiana 46517

BOOTH #2346 at the World Media Expo.

TAG 2020

TELEPHONE AUTOMATIC GAIN

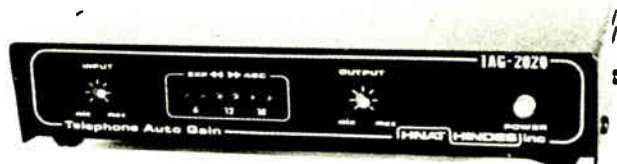

A PROCESSOR FOR ALL SEASONS

- ★ BASEBALL SEASON
- ★ BASKETBALL SEASON
- ★ FOOTBALL SEASON
- ★ HOCKEY SEASON

FEATURES: BROADBAND OR BANDPASS FILTERED MIC OR LINE INPUT (SELECTABLE)
OPTIONAL AUTO-ANSWER BOARD
DIFFERENTIAL LINE OUT

HINAT HINDES Inc

42 ELAINE ST. THOMPSON, CT 06277 TEL203-935-9066/9242/9919FAX

Circle (179) On Reader Service Card

Circle (159) On Reader Service Card

INTERNATIONAL UPDATE

Internet Offers Radio Unique Opportunities

by James Careless

OTTAWA Chris Boyce was researching a piece on the Internet Underground Music Archive for "Brand X," a CBC radio weekend show whose target audience is those "Generation X" 18 to 29 year olds struggling with life in the '90s.

He could download a biography of the band in which he was interested. He could even get a picture of the band and one of the group's songs directly off the Net. But unfortunately for Boyce, an associate producer, the band was in the United States.

The interviewer was in Canada.

However, the situation did not faze "Brand X" producers.

Interview on 'the Net'

Rather than making the choice between cost and quality in how to conduct an interview, they ask one of the group's lead guitarists to record his end of the interview on his computer.

"He said 'Sure, got a mic right here,'" Boyce said. "He plugged it in, called up the sound digitizer program, and we did the interview right then and there."

The guitarist, in turn, sent the interview to "Brand X" via Internet. "He put it up in an FTP site (one of many Internet 'server' computers that allow users to upload and download files)," Boyce said, "and we had it 20 minutes later."

Such is one example of how the Canadian Broadcasting Corp. (CBC) uses Internet, the largest computer network worldwide, as an extremely valuable resource.

First and foremost, the range of "news-groups" on the globally-accessible Internet public message forums—whose

topics cover everything from aquariums to sex—provides CBC radio researchers with a ready-made source of story ideas. As well, the Internet organization of discussion groups differentiated by topic makes it easy for researchers to find the right people to interview.

Research made easier

"I know that somebody in one of our radio shows put out a query on the Internet asking 'Was there anybody who had been at the D-Day landings and could remember such-and-such a thing?'" said Michael Bidder, CBC Corporate Telecommunications Director. "There was a lot of responses from that, which they then followed up on a one-to-one basis."

The second major advantage of the Internet for radio is audience contact.

"Just having an e-mail (electronic mail) address where people can write to encouraged a lot of people who wouldn't communicate with us otherwise to respond to the show," Boyce said.

The proof is in the numbers. When "Brand X" linked to Internet, Boyce recalled, the staff started receiving 40 e-mails a week, as compared to one to two responses from mail, voice, and fax connections combined.

"Brand X" is not the only CBC program to experience such a flood, said Jason Remillard, the CBC Computer Systems Support specialist who guided the program's introduction to the Internet. Another program that saw immediate results was "Cross Country Checkup," the CBC national Sunday phone-in show.

"When they first broadcast their e-mail address," Remillard said, "they got 200 within the first hour."

Another benefit with Internet for radio is it offers a new medium for broadcasters to transmit programming, namely by allowing them to digitize audio into "sound files," then to make those files available to any and all of the Internet 30 million users.

CBC has experimented with this novel form of program transmission for some time. Initially, the organization loaded a few sound files into a computer server at the government-run Communications Research Center in Ottawa.

Broadcasts on Internet

Now, given the success of those trials, CBC is setting up a server in-house, which will offer Internet subscribers with sufficiently high-speed modems, the opportunity to sample numerous CBC radio programs, including a major daily newscast and five-minute-long segments of "Brand X."

According to Bidder, the Internet service will start modestly and eventually will evolve. "If you missed your favorite show on Wednesday night, you can go in and get it off Internet," he said, projecting future uses.

Still, there is a limit to how much audio can be transmitted this way, Boyce said. "Digitizing audio at high sampling rates so that it's good enough quality to use (on air) uses a significant amount of storage space," he said. "The interviews we were doing were compressed, and they were

continued on page 14 ►

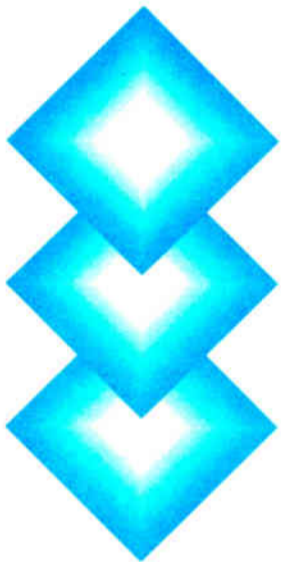

OUR REPUTATION SPEAKS FOR ITSELF...

1994 BROADCAST EQUIPMENT SURVEY

FM TRANSMITTERS

	% OF TOTAL REPLIES	BUY AGAIN	RECOMMENDED
B.E.	17.95%	85.71%	85.71%
COLLINS	7.69%	66.67%	33.33%
Continental	28.21%	100.00%	100.00%
HARRIS	28.21%	72.73%	72.73%
RCA	8.97%	28.57%	28.57%
OTHER	8.97%	28.57%	42.86%

Printed with permission of Taurus Publishing



Continental Electronics Corporation

P.O. BOX 270879 DALLAS, TEXAS 75227-0879 214-381-7161 TELEX 73-398 FAX 214-381-4949

7.94-017

Circle (167) On Reader Service Card

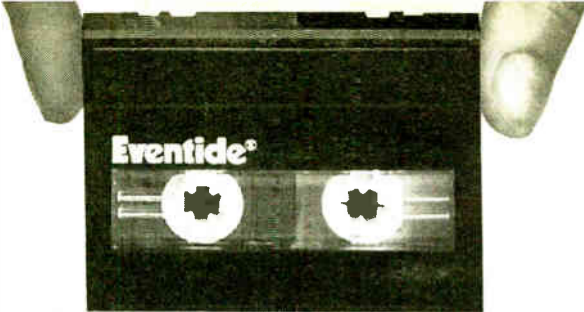

LOG FOR LESS

Everyone loves Eventide digital audio-loggers. They've thoroughly obsoleted old-fashioned reel-to-reel logging recorders. But for some stations, our 24-channel model VR240 is more than the budget can handle. And many stations will never need to record up to 24 channels.

500 hours, half the price

The Eventide VR204 4-channel digital logger is the perfect answer. It costs less than half the price of a fully optioned Eventide VR240! The high density DDS2 drive of the VR204 can actually record more than 500 hours, divided among up to 4-channels, on a single DAT tape. That's twice the record time of our original models.

Built-in hard disk

The VR204 is a single drive machine, yet it can play and record simultaneously. That's because it features an ingenious built-in hard disk memory module that keeps recording even if the tape is playing back an

earlier segment (or if the tape runs out). When the tape resumes recording, the content of the hard disk is transferred to tape, maintaining the completeness of the taped log.

Two-way compatibility

There's also a play-only model, the VP204, which is ideal for the GM's or PD's desk or for the group's main office. And both the VR204 and VP204 can playback any of the 24 channels recorded on an Eventide VR240.

Keep an accurate audio record of everything that goes out on your air. Keep track of the competition as well. Contact your broadcast dealer or Eventide for the full story on the economical VR204. Because without an Eventide digital logger, you really don't know what you're missing.



**Now record
500+ hours on
one tiny DAT tape**



Eventide
the next step

One Alsan Way, Little Ferry, NJ 07643
Tel 201-641-1200 Fax 201-641-1640

INTERNATIONAL UPDATE

Europe DAB Proponents Confident About DAB

by Mary Ann Seidler

FREISING, Germany Although worldwide implementation of the Eureka-147 digital audio broadcasting was uncertain in 1993, the scenario is more positive in 1994. Pilot projects are planned in many nations, more manufacturers are developing equipment and even China has expressed strong interest in DAB.

Last year, it was a different story. The German federation of broadcasters, ARD, announced that due to financial restraints they would not implement DAB in Germany by 1995. It seemed many nations were questioning when they would start with DAB, too.

Egon Meier-Engelen, director of the DAB project in Germany, said that renewed interest in DAB owes much to what happened last year. "What a difference a year can make," he said.

The ARD decision made DAB groups worldwide step back and question whether they would go ahead. They decided to re-evaluate their dedication to new band DAB systems, and ultimately

they decided to push ahead. Meier-Engelen, who has been involved

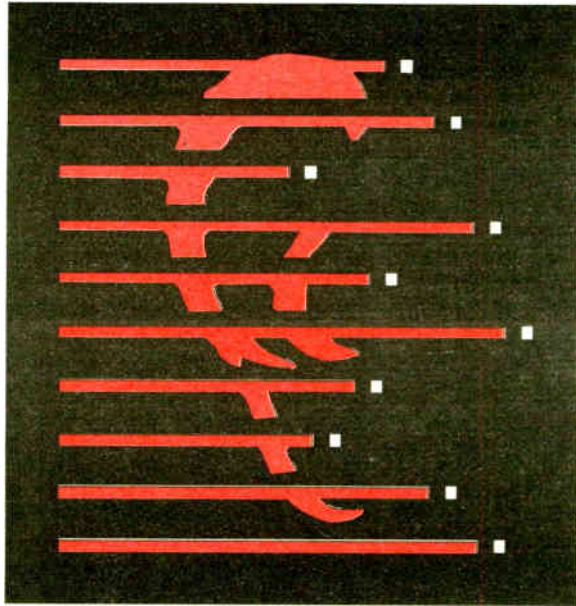

with Eureka since 1985 (the official start was in 1988), said public comments on the standard were closed 12 August 1994.

The draft standard goes to the joint technical committee of EBU/ETSI (European Broadcasting Union/European Technical Standards Union) for approval late this fall, and the official standard manufacturers need to build their equipment will be issued by the end of the year. Phase II of the development will be complete by January 1995.

Grundig of Germany will deliver 3,000 to 5,000 consumer DAB receivers for a pilot project set to start in Bavaria next year. Edward Gartner, engineer in charge of the DAB project for Grundig, said the DAB receiver package will include an antenna, a car radio, a DAB receiver and cables.

Although the receiver is fairly small, Gartner said he thinks, for this test, it will probably be fitted in the trunk of the car, not unlike currently available CD changers.

Specific plan

Gartner said that following this pilot project, the first generation of mass market DAB receivers will be ready in 1997. Grundig did not wait for publication of the final DAB

standard to begin work. He said the company has had a specific plan for manufacturing these receiver for some time now.

BBC Research and Development also is working on DAB equipment in the United Kingdom. According to Paul Ratliff of the BBC, it has developed an experimental DAB CODFM generator and multiplexer. These units allow a flexible choice of multiplex configurations and will accommodate use of 2Mbit/ data links for distribution. Like Gartner, Ratliff said he does not foresee any major changes to the equipment once the final standard is published.

The BBC needed its experimental equipment ready quickly because of the large scale U.K. pilot project already underway. The BBC plans to actually be transmitting regular programs in a short time.

Several other countries are hard at work on their own DAB transmitter systems. Canada already has sites in Toronto and Montreal with Ottawa and Vancouver coming shortly.

Since last year, receiver manufacturer interest in DAB has grown dramatically. Sony, Delco, Pioneer and Nokia now have joined Eureka-147. Negotiations and discussions also are ongoing with several other large manufacturers.

DAB interest spreads

DAB interest is spreading out from Europe and Canada. Meier-Engelen said that in November, the Eureka team will make a formal presentation to the Arab States Broadcasters meeting in Tunis, Tunisia. Australian interest in DAB also has picked up dramatically in the past year. Recently both India and China expressed interest in learning more about the DAB system and its implementation. The number of state broadcasters exploring the possibilities of DAB continues to grow.

In 1995, DAB will enter Phase III development. In Phase III, the discussions over standards, and exactly what DAB is, will end and real-world implementations of DAB will come to the forefront.

□ □ □
Mary Ann Seidler writes regularly on digital audio broadcasting for *Radio World International*. 

Internet Increases In Radio

► continued from page 12

still about 5MB which, if you have a high-speed modem or a direct connection to the Internet, is going to only take you half an hour to an hour to pull down. But still that's a large amount."

Bidder added that the problem of data transfer speeds—a situation the much-discussed "information superhighway" is expected to resolve by vastly boosting transmission rates—makes the Internet impractical as an alternative broadcast medium.

"I would question why people would go through Internet to get that (programming)," Bidder said, "when they can go through their radio and get that in real time."

There are other ways in which the Internet is still a far-from-perfect tool for radio. When it comes to research, Remillard said, Internet lacks a comprehensive indexing system. "You can waste hours and hours on the Net, just looking for one specific item," he said.

As well, there could be legal problems associated with distributing programming through the Internet, Bidder added. "The thing that worries me a little, and I'm not sure that we've looked into that in-depth yet, is the copyright issues. We pay royalties at the moment for a lot of things that we put on the air. If we put it on Internet, how many times do we pay the royalty, because once somebody picks it up from there, they can do what they like with it."

Finally, there is the challenge of ensuring that hackers do not use the Internet to raid and rampage through CBC computers, something Bidder's people are working to prevent.

"We don't want people from the great wide world getting into our network and into our systems. So we're building what's called a 'fire-wall,' which is something like a one-way valve," he said.

"We can transmit through it, and then replies from the Internet come to the server. We can pick them up, but they don't actually flow through into the network."

Using the Internet is not without its problems for CBC radio. Still, the benefits obviously outweigh the negatives. That is why the CBC is abandoning its current piecemeal approach to Internet access—with individual programs linking up through external service providers on their own initiative—and establishing its own dedicated gateway for the benefit of all CBC programmers by the end of September.

□ □ □
James Careless covers the industry for *RW* in Canada. 

TRANSMISSION SOLUTIONS

Nearly 500 Broadcasters Have Found That Harris DX Transmitters Practically Pay for Themselves.



With typical AC to RF efficiency of 85% or better and the lowest life cycle operating cost of any AM transmitters. From 10 kW through 2 MW. To learn how a Harris DX transmitter can increase your profits, please contact our radio sales department by fax (217-224-1439) or by phone:

217-222-8200

 **HARRIS ALLIED**

P.O. BOX 4290 • QUINCY, IL 62305-4290

©Harris Corporation 1994

Circle (114) On Reader Service Card



RTNDA 1994

World Media Expo

P · R · E · V · I · E · W



RADIO THE NAB SHOW

First World Media Expo Opens in LA

by John Gatski

LOS ANGELES In what organizers hope is a sign of broadcast trade shows to come, the first annual World Media Expo gets underway Oct. 12-15 at the Los Angeles Convention Center.

Hundreds of attendees are expected to flock to a huge exhibit area of about 443 audio and video companies and separate conferences conducted by the National Association of Broadcasters, Society of Broadcast Engineers (SBE), Radio Television News Directors Association (RTNDA) and the Society of Motion Picture and Television Engineers (SMPTE).

cope with it.

The Digital Radio Seminar: Preparing for DAB is scheduled for Thursday, Oct. 13. It is described as "an intense, no-nonsense, one-day briefing for general managers, engineers, operations managers and group operators designed by experienced broadcasters to prepare you to guide your facilities safely and profitably into the digital age."

Individual sessions will include digital audio workstations, LANS vs. WAN, an update on DAB systems testing, digital compression, and multimedia.

NAB's quality AM Antenna Seminar will be held over two days, Friday-Saturday, Oct. 14-15. This also is an

intensive workshop that will help stations maintain and maximize AM performance. The intended audience includes general managers, engineering managers and group owners.

Those looking to get an update on FCC and other regulation-related news will not be disappointed. A number of presentations are planned, according to the NAB schedule.

With the fall NAB show's tradition of appealing to programming and management personnel, there will be a number of related sessions and speakers going during the three-day show. Subjects to be covered include programming, ownership, maximizing revenue, legal issues and promotions.

The NAB will, of course, present its Marconi Awards to 1994's outstanding stations on the last night of the show and famed commentator Paul Harvey will be the keynote speaker at the NAB Radio Luncheon on Friday. The Radio Advertising Bureau will conduct a number of panels,

and the NAB will also hold its law and regulation conference.

SBE out in force

The SBE schedule is chockful of interesting sessions during the World Media Expo. The Ennes Workshop is scheduled for Wednesday, Oct. 12. The Ennes schedule includes a tour of the Los Angeles antenna farm on Mt. Wilson, computer systems workshop, workplace safety workshop, tour of the Los Angeles County Emergency Operations center and a session on emergency preparedness, and the all-important contract engineering session.

On Thursday, pertinent SBE radio sessions will include an update on the FCC/FAA jurisdictional squabble over broadcaster regulation and broadcast auxiliary issues. SBE management sessions will highlight broadcasting trends, engineering budgeting and engineering management. The SBE membership meeting and opening reception are also scheduled for Thursday.

On Friday, Oct. 14, SBE sessions begin with New Technology for Radio Part I. Topics to be covered include diplex design for shunt-fed towers, power tube rebuilding and analysis. New Technology for Radio Part II will highlight remote controlled processing, new

changes and the latest on the ANSI/IEEE RF radiation standard now being considered for standardization by the FCC. The annual SBE awards banquet and reception are scheduled for Saturday night at the New Otari Hotel.

The latest news

The RTNDA conference will be a star-studded event (journalistically speaking, of course,) with the latest in newsgather-

The Digital Radio Seminar will prepare you to guide your facilities safely and profitably into the digital age.

AM antenna developments, and lightning protection.

Look for SBE's shortwave sessions, also scheduled for Friday, including an update on the booming resurgence in private shortwave broadcasting in the U.S.

The final day of the convention, Saturday, Oct. 15, for SBE registrants will focus on the latest in EBS news and technology including the pending FCC rules and an update on the EDIS system. The New Digital Technologies morning session will include linear amplification of digitally modulated RF, transcoding and digital compatibility, and an update on the ISO/MPEG layers. Subjects to be covered in the afternoon are: ISDN and Switched 56 using data compression, the use of ISDN, and integration of digital audio in production, archival, and retrieval.

Two important afternoon sessions will focus on the NAD83 coordinate system

ing and distribution advances. Throughout the three days, speakers will include Andy Rooney, "60 minutes," the 1994 RTNDA Edward R. Murrow award winner; Tim Russert, "Meet the Press"; Dick Shapp, ABC News; Jane Pauley, NBC News; Cokie Roberts, ABC News; Michael Kinsley, Pat Buchannon and John Sununu, CNN's "Crossfire"; and Charles Kuralt, formerly of CBS News. Former presidential candidate and South Dakota senator George McGovern also is scheduled to speak.

Scheduled RTNDA sessions will cover such topics as radio news critiques, news of the future with overview of technology, an outline of the news business profit partnerships for radio/television, covering crime, computer assisted reporting, the law and the news, differences in commercial radio and public radio news coverage, disaster reporting and writing for broadcast news.



The Los Angeles Convention Center

The World Media Expo stems from NAB's fall radio show and SBE, RTNDA and SMPTE's separate conventions that have taxed vendors and attendees over the past few years because they have had to spread resources out over multiple shows. With the World Media Expo, there is a certain economy of scale, according to the organizations.

The NAB, which is handling the exhibit area, reports that interest in radio equipment manufacturers is well ahead of past radio shows. So far, the 218 exhibitors amount to about 53,400 square feet of exhibit space—just for radio. Overall, NAB is expected to sell 130,000 square feet of space. Besides the vast number of exhibitors, the NAB also will have the latest in broadcast technology displays.

Early events

As far as the individual conference, NAB will have its Engineering Management Seminar the day before the show opens, Tuesday Oct. 11. The theme for this seminar is change and how to

SINE SYSTEMS

Walkaway Specialist: Innovative Solutions

- EBS Compliance Tools
- Remote Transmitter Control & Monitoring
- Dial-up Remote Broadcast
- Program Automation Accessories & Studio Aids

(615) 228-3500
FAX 227-2367
1020 Maxwell Avenue, Nashville, TN 37206-3554

24 Hour FAX
ON-DEMAND
(615) 227-2393

Circle (204) On Reader Service Card

Numerous Companies Plan Exhibits

WASHINGTON Early exhibitor and broadcaster registration for the World Media Expo "supershow" indicate that manufacturers and broadcasters have embraced the idea.

Convening in Los Angeles for the first meeting of an eight-year contract, the National Association of Broadcasters (NAB), the Radio-Television News Directors Association (RTNDA), the Society of Broadcast Engineers (SBE), and the Society of Motion Picture and Television Engineers (SMPTE) are making the most of the efficiencies of scale.

NAB oversaw the sale of exhibit space on the combined exhibit floor. At press time,

443 companies had signed on to share roughly 130,000 square feet of exhibit floor space. The radio/audio pavilion attracted 218 exhibitors into 53,400 square feet of exhibit floor—surpassing last year's record-breaking Dallas NAB Radio Show.

Rick Dobson, senior vice president conventions and exhibits for the NAB, said the NAB is "very pleased" with the way the show has come together. "We were and are very pleased with the way the exhibit hall has come together," he said. "It was hard to predict the turnout with great accuracy because we had nothing to compare it to."

At press time Dobson reported, the radio/audio pavilion had set a record by post-

ing the largest percent increase in growth of floor space in one year (comparing just the radio shows to the radio/audio pavilion). The 1993 Dallas Radio Show covered 42,200 square feet of exhibit floor, occupied by 195 exhibitors.

The enthusiasm manifest in the number of exhibiting companies seems to have carried

over into the number of registrants as well, according to Dobson. Speaking only for NAB, as each association is handling its own registration, Dobson said registration for the Radio Show was pacing far ahead of last year.

It helps, he added, that the show is positioned in the largest radio market in the U.S. "My feeling is that radio attendees, given that we have separated out the pavilion, will find the whole thing very efficient," he said.

SBE Positive about WME

by John Gatski

LOS ANGELES The Society of Broadcast Engineers (SBE) is looking forward to being part of the 1994 World Media Expo. The organization hopes to recover interest that had waned somewhat during recent SBE's stand-alone conventions.

According to SBE Executive Director John Poray, the organization hopes to have 300 or more members attend the SBE schedule of conference and events. The World Media Expo is a joint-show of separate conferences from SBE, NAB, the Radio-Television News Directors Association (RTNDA) and Society of Motion Picture and Television Engineers (SMPTE). All have of separate conferences, but all exhibiting companies share the Los Angeles Convention Center exhibit space.

Poray said the organization has begun building goodwill with disenchanted members who a couple of years ago threatened to or actually withheld dues. A controversial dues increase angered many members. Members also had complained of the constantly changing

venues of the national convention.

But Poray said most of those bad feelings have been left behind, and most of those that have withheld their dues have paid. He said attendees will be pleased with the schedule at the World Media Expo.

"It's going to be a super show for our guys," he said. He pointed to the diverse

number of sessions, the Ennis Workshop and certification courses and a tour of Mt. Wilson as examples of the activities that will peak member interest.

"It's going to be an excellent show," SBE Vice President Terry Baun said. "We've got a great series of sessions."

Baun said the combination NAB, SBE, RTNDA and SMPTE exhibit floor, likely to be 300 or more vendors, accompanied by separate conferences is a reflection of an industry trend. "We all have our own organization, but we play on the same playing field," he said.

Baun also echoed Poray's sentiments that considerable healing has taken place since the controversy over dues erupted in 1992 and 1993. "I think it's in the past. We are working hard at it. It's a matter of communication."



Nothing could compete with the wildly popular EV 635A—until now.



Introducing the 635N/D—the same "nail-hammering" durability—infused with the power of N/DYM®

THE ELECTRO-VOICE 635N/D AND 635N/D-B (CAMERA BLACK) MICS MAY LOOK AND SOUND LIKE THE LEGENDARY 635A, BUT THERE ARE SOME VERY POWERFUL DIFFERENCES. WE'VE ADDED A NEW, ULTRAHIGH-OUTPUT NEODYMIUM IRON BORON MAGNET ASSEMBLY (N/DYM®). THEN CRADLED IT IN AN EVEN MORE PROTECTIVE STRUCTURE—FOR QUALITY AUDIO UNDER EVEN THE MOST DEMANDING NEWS/FIELD CONDITIONS.

WHEN THERE'S ONE CHANCE TO GET IT RIGHT CALL 800/234-6831.



Electro-Voice, Inc. a MARK IV company 600 Cecil St. Buchanan, MI 49107 616/695-6831 In Canada: 613/382-2141

Circle (214) On Reader Service Card



You can measure...

with the best monitor and the most accurate test set.

The FMM-2/FMS-2 series monitors provide an even greater degree of precision measurement than ever before... You can measure S/N below 90 dB, You can measure crosstalk below 85 dB, You can measure separations of better than 70 dB, You can measure frequency response to better than 0.25 dB, You can measure distortions to lower than 0.01%, and much more... Our uncluttered panels and autoranging voltmeters make these measurements a dream.

BELAR ELECTRONICS LABORATORY, INC.
LANCASTER AVENUE AT DORSET, DEVON, PENNSYLVANIA 19333

(610) 687-5550

Call or write for more information on Belar AM, FM, Stereo, SCA and TV monitors.

Circle (105) On Reader Service Card

See Us At WME Booth 2915

We've been advised that it's a total waste of time to advertise to broadcast engineers.

We're told that you folks are so conservative that you only drive beige, four-door 1978 Plymouth Reliants and wear polyester slacks with Ban-Roll waistbands. So conservative that you consider pocket protectors a new fashion fad. So conservative that 6-year-old, still-wet-behind-the-ears mixer company has very little chance of gaining any acceptance with an audience this demanding.

Call us overly optimistic, but we're still convinced that you'll appreciate our products. Someday. Hey, we **HAD** to be optimistic to get into this business. It wasn't like there weren't any compact boards already on the market.

In spite of the odds, our CR-1604 and MicroSeries 1202 mic/line have become widely accepted in recording, live performance and video production circles. Besides having more headroom than a Kenworth truck cab and less noise than a morgue at midnight, our mixers have a reputation for being incredibly reliable. Bullet-proof, even.

Now, we're not suggesting you make a Mackie compact mixer your main, on-air console or anything. In fact, the only place our current product line might get in your live signal chain is during a remote (The MS1202 12x12 mic/line mixer is getting quite popular for this application). But we've been around stations enough to know that reliability is a key factor anywhere, even in that broom closet they made you convert into a production room.

Finally, our mixers are incredible values. Buy a Mackie CR-1604 and you're getting a mixer that's regularly used to create major label compact discs and more commercial production work than you can shake an RE20 at...for just \$1099¹. Unless your GM as suddenly snapped and offered you an unlimited capital equipment budget, this is a major consideration.

So prove everybody wrong who says broadcast engineers are too conservative to call a toll-free number, or contact your favorite broadcast supply house.

IN SPITE OF RADIO ENGINEERS' LEGENDARY CONSERVATISM, WE'RE RUNNING ANOTHER AD.



3-band equalization done right: $\pm 15\text{dB}$ at 80Hz, $\pm 12\text{dB}$ at 2.5kHz (perfect for voices), $\pm 15\text{dB}$ at 12kHz. Far more useful than traditional 100Hz, 1KHz, 10KHz EQ.

Sealed rotary potentiometers resist contamination from dust, liquids and smoke. Plus they have a smooth, positive feel without a trace of wobble.

The Mackie Designs 16x2 **CR-1604 Mic/Line Mixer**. Suggested retail price, \$1099¹. Available at America's top broadcast supply houses.

Six recording studio-grade microphone preamps with +48VDC phantom power. Discrete circuitry with four conjugate-pair, large-emitter geometry transistors delivers -129.6dBm E.I.N., 300K bandwidth, 0.005% THD...and incredible headroom. A Very Famous Maker of Expensive German Microphones uses a CR-1604's preamps to demo their mics at tradeshows.

Solid steel main chassis.

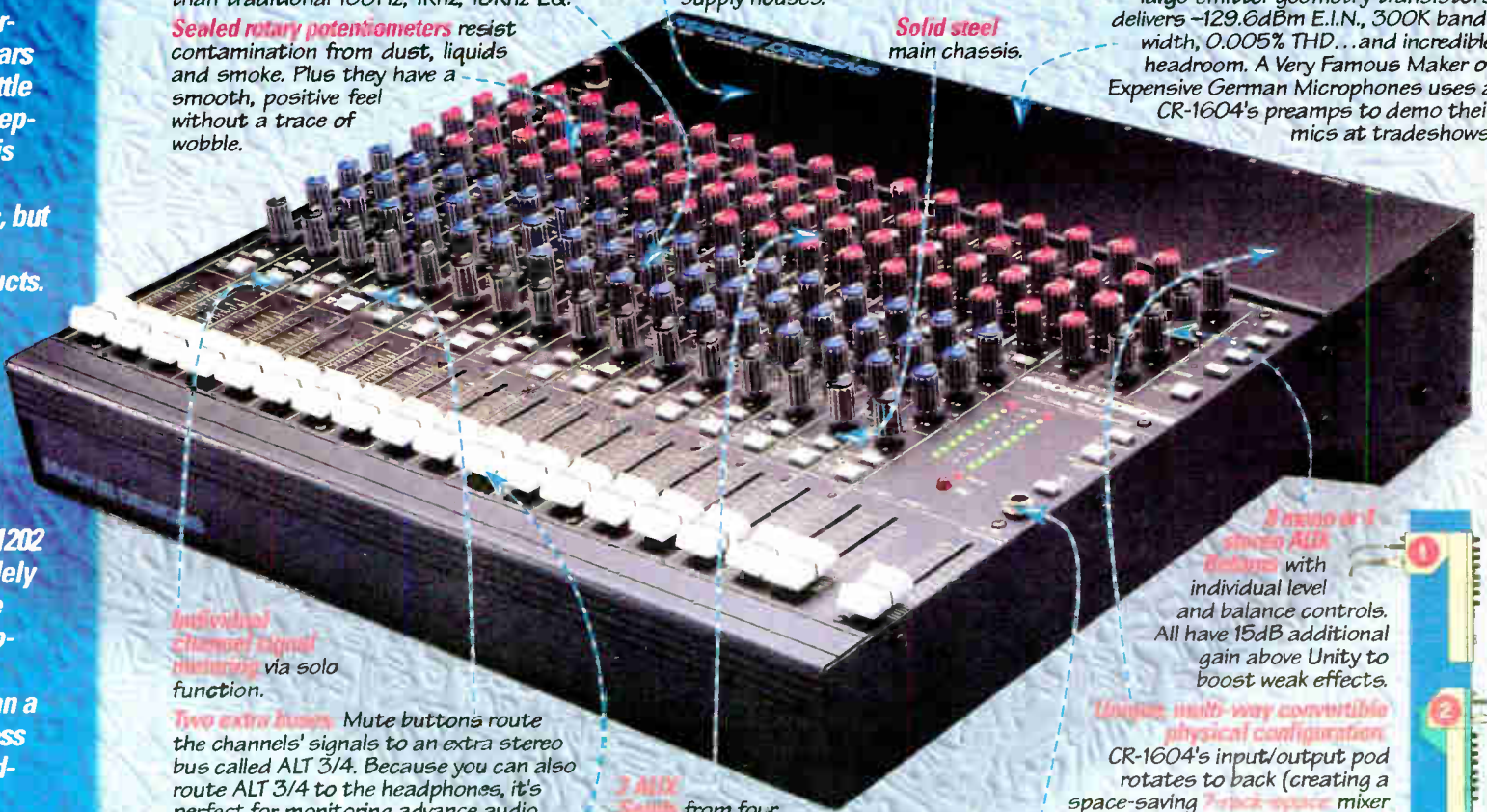

Individual channel signal monitoring via solo function.

Two extra buses. Mute buttons route the channels' signals to an extra stereo bus called ALT 3/4. Because you can also route ALT 3/4 to the headphones, it's perfect for monitoring advance audio cues: Preview a signal that hasn't been brought up in the mix yet...then add it by unmuting the channel.

UnityPlus gain structure gives high headroom and low noise at the same time. Set the fader to center-detent Unity Gain, press channel solo to monitor the channel via the CR-1604's LED meters, adjust the input trim ONCE, and you're ready. Because there's 20dB MORE gain available on the fader, you won't need to constantly re-adjust the trim.

3 AUX Sends from four knobs. AUX 1 can be used as an effects send or headphone monitor cue via the MON. Sends 3 & 4 become AUXs 5 & 6 when the SHIFT button is pressed. All sends give you 15dB more gain above Unity so that you can get tons of effect even when the channel fader is pulled down.

Powerful headphone amp (with volume control) drives any phones to head-banging levels even an AOR production person will appreciate.

3 mono or 1 stereo AUX Returns with individual level and balance controls. All have 15dB additional gain above Unity to boost weak effects.

Unique, multi-way convertible physical configuration. CR-1604's input/output pod rotates to back (creating a space-saving 7-rack mixer shown in Fig. 1), or to front (12-rack version, shown in Fig. 2) with our optional RotoPod bracket. Use the CR-1604 on a **tabletop** with jacks on the same plane as the controls via the RotoPod bracket (Fig. 3 below), or **jacks to top** (Fig. 4). Our XLR10 Mic Preamp Expander can also be added in any of these configurations.

Rugged design and construction. Including mil-spec, double-sided, thru-hole-plated fiberglass circuit boards (horizontally-mounted on brass stand-offs for impact-resistance), double-parallel-wired faders for 2-times redundancy, and electronic protection against power surges, impedance mis-matches and static discharges.

Better-than-digital specs and headroom. The CR-1604 has a dynamic range of 108dB and an internal S/N ratio of -116dB (versus compact discs' 96dB dynamic range.) This means you're getting a mixer that can handle the output of digital workstations, CDs and DAT tapes without overload.



Maximized RFI protection. Most compact mixers use plastic jacks that transmit RFI to the main circuit board where it's re-radiated and picked up by anything that rectifies (A). The CR-1604 uses metal jacks and washers plus a shunting capacitor to de-rail RFI before it gets to any circuit traces (B).

A **Radio World** reviewer tested a CR-1604 on a transmitter hill with 3 VHF TV and 1 FM sticks plus several microwave repeaters and shortwave transmitters. When he plugged in a notoriously RF-prone microphone, he detected NO audible RF interference.

Not shown: Inserts on Chs. 1 thru 8, main left/right bus inserts, phantom power switch, balanced/unbalanced main stereo outputs and separate mono output. XLR10 Mic Preamp Expander connects to the CR-1604 pod to provide 10 more preamps complete with trims and phantom power.

A chip off the old block: Perfect for remotes, our MS1202 12x2 Mic/Line Mixer has 4 of the same superb mic preamps that distinguish our larger CR-1604, plus phantom power, 2 AUX sends/ch., 2 stereo AUX returns, channel patching, 2-band EQ, 3-way 12-LED peak metering, headphone monitor amp with level control, built-in power supply. Suggested retail is just \$399¹!



MACKIE

MACKIE DESIGNS INC. • 20205 144th Ave NE • Woodinville, WA • 98077 • 800-898-3211
FAX 206/487-4337 • Outside the U.S. call 206/487-4333 • Represented in Canada by S.F. Marketing 800/363-8855

Circle 157 On Reader Service Card
World Radio History

¹ Price is slightly higher in Canada.

If you've been quietly suppressing a monumental *urge* to smash the living *HECK* out of every single noisy, clumsy **CARTRIDGE** that's been jamming up your carts for the last *umpteen* years, **NOW** would be an *extremely opportune* time to *VENT* all that pent-up **Rage!**



Take out that old NAB cart and plug in Otari's new MiniDisc!

It's as easy as that! And you get fast random access editing, auto-programming for commercial sequences, digital I/O, and high quality digital sound for transparent copies. For flexibility, Otari's MiniDisc recorder/player delivers a next-play function and auto cue, plus optional RS-422.

In short, Otari's MiniDisc is the perfect cart replacement.

And at the same time, you get Otari's legendary "workhorse" reliability for on-air dependability. Call your local Otari dealer for information about how the powerful, yet easy-to-use Otari MiniDisc cost-effectively meets your on-air and production requirements.

OTARI

Otari Corporation
U.S.A.
Phone: (415) 341 5900
Fax: (415) 341 7200
N.Y. Sales: (212) 297 6109
L.A. Sales: (818) 972 3687

Otari Inc.
Japan
Phone: (81) 4 2481 8626
Fax: (81) 4 2480 8633
Telex: J26604 OTRDENKI

Otari Deutschland GmbH
Germany
Phone: (49) 2159 50861 62 63
Fax: (49) 2159 1778
Telex: 8531638 OTEL D

Otari Singapore Pte., Ltd.
Singapore
Phone: (65) 284 7211
Fax: (65) 284 4727
Telex: RS36935 OTARI

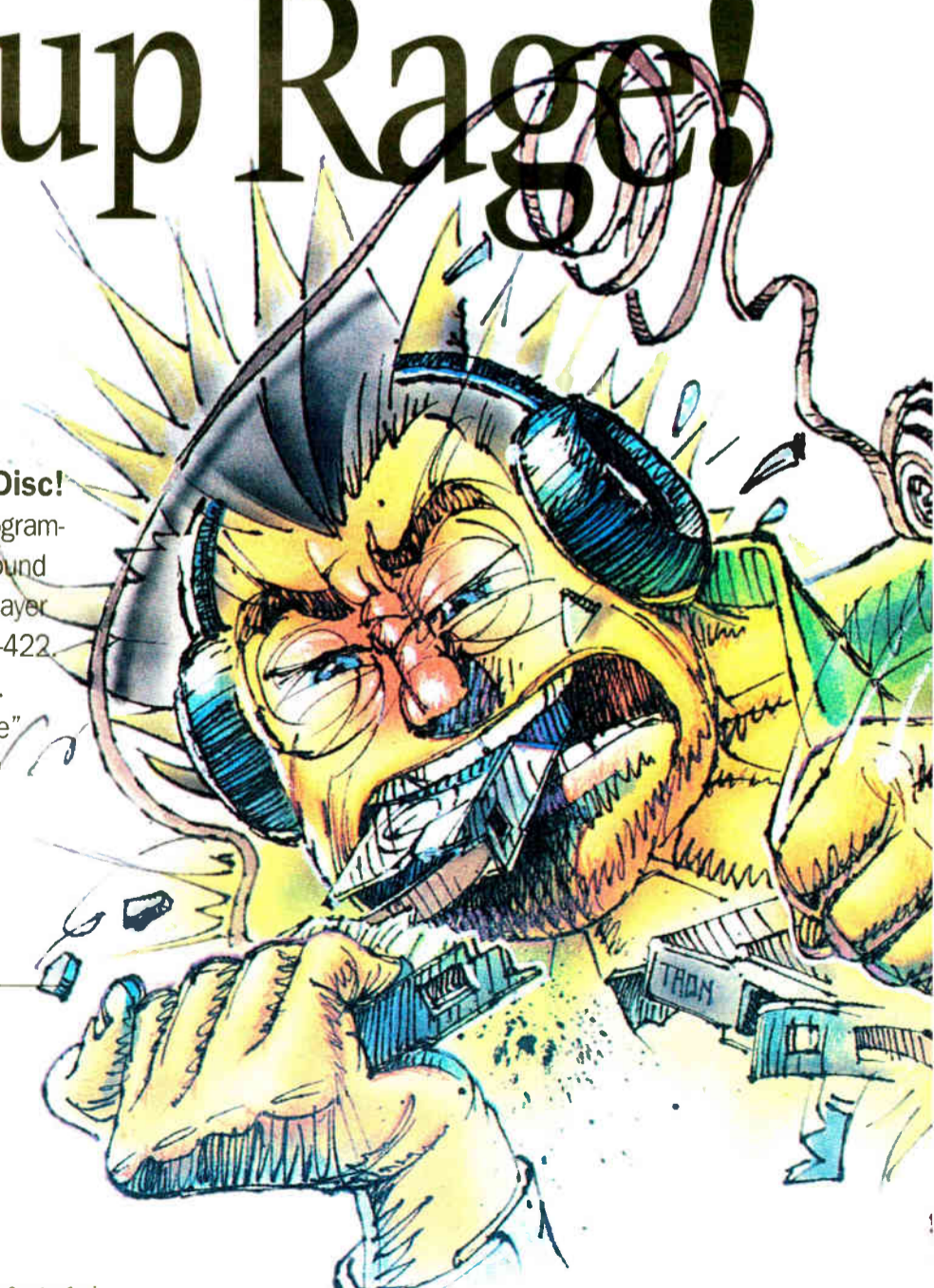

RAB Sessions Focus on Ads, Marketing

by Wayne Cornils
Executive VP/Services
Radio Advertising Bureau

NEW YORK "What makes radio people wake up screaming in the middle of the night?"

That was the question put before the Sales and Marketing Committee of the NAB Fall Convention during its planning meetings. The committee, chaired by Jim Champlin of Beck-Ross Communications with assistance from RAB President Gary Fries, me and a host of radio's leading sales managers and consultants, sets the agenda of sales and marketing workshops offered at the NAB Convention.

Our goal: Determine the topics and issues that will be front burner for most radio stations in the coming year—not just what's hot in October 1994 but, perhaps more important, what will be shaping our industry in October 1995.

A unique challenge

The issues we identified ran the gamut from new radio marketing techniques and revenue opportunities to the challenges confronting radio stations who may find that their specialized needs for information and/or support are not being met on a wide scale within the industry.

Immediately, the unique challenges facing the rapidly growing urban/black and Hispanic segments of the industry came to mind. The committee responded by scheduling special workshops directed at addressing—and solving—the problems and challenges unique to marketing these specialized formats.

The radio industry changes so quickly that new opportunities for growth are always being uncovered. We chose to focus on a few of the newer areas which we felt might hold the key to even greater growth in the future. Among them is sports marketing, which is attracting more and more radio stations. Today, sports marketing means more than just play-by-play rights; hundreds of stations are getting involved in on-air as well as off-air opportunities to produce revenue—all of which will be covered in the sports marketing workshop we added to the line-up.

Database marketing

Database marketing and event marketing are two other areas whose potential most radio marketers are just beginning to recognize. Though database marketing is being implemented by more and more radio stations, there seems to be quite a bit of confusion, if not downright disagreement, over how best to use the data they contain.

Some stations spend thousands and thousands of dollars marketing to their listener databases to build both core listenership for themselves and customized marketing program for their clients, while others seem to be content with merely collecting names and addresses. The committee asked both database consultant Peggy Miles and some of the broadcasters leading the database marketing wave to address the issues.

Change, the committee observed, is becoming increasingly prevalent on not

only the industry level but the everyday station level as well. How well we can adapt to or even stay ahead of the changes taking place all around us will directly impact our ability to prosper in the coming year. With that in mind, we asked Norm Goldsmith to confront the issue head-on in a workshop for station people called "Create, Control and Profit from Change."

Once we had addressed change in its broadest sense, we began looking at some of the most significant changes taking place in our business. That, of course, led to a discussion of how duopolies have altered and will continue to alter the face of radio broadcasting. The committee members felt very strongly about providing first-hand, face-to-face advice for

Then we considered some of the things about radio that we'd like to see change. Among them was the fact that radio is behind other industries in adopting newer and more progressive compensation systems for its salespeople, so we asked Sales Trainer and Group Executive Chuck Mefford to detail his company's success in implementing new compensation systems.

More ad dollars

Other things we'd like to see done differently in radio? Easy. We'd like to be getting more ad dollars from agencies. We called in Dave Gifford for a session called "Getting Your Unfair Share of Agency Business." Among the tools radio people need to grow their ad dollar share is negotiating skills, which world famous speaker, trainer and author Roger Dawson will provide in a session on the topic.

But the changes concerning us aren't just taking place within our industry;



The committee responded by scheduling special workshops directed at addressing—and solving—the problems and challenges unique to marketing these specialized formats.

broadcasters in large, medium and small markets on the ups and downs of every facet of the duopoly experience.

Changing face

Another issue we felt needed to be brought to the attention of broadcasters: the changing face of radio research. The committee's real concern that many broadcasters know little about some of the new research tools changing the way radio is being bought at the agency level prompted us to create a workshop on "Block Group Coding."

they're taking place in our client industries as well. Retailing is a prime example. When mass marketers like Wal-Mart, Kmart, Target and others come to a community, many things change. Things like shopping patterns, volume discounts, mass buying power, advertising dollar allocation and threats to smaller local retailer, among them. We decided to devote a workshop to explain not only what's happening but what stations should be doing in response.

People in our business—as is the case with most—are concerned about the

Exhibition Schedule

Thursday, October 13

9:00 a.m. to 6:00 p.m.

Friday, October 14

9:00 a.m. to 6:00 p.m.

Saturday, October 15

9:00 a.m. to 4:00 p.m.

future: What it will hold, how it will impact radio operators, marketers, the way we do business, and the way we earn money. Who wouldn't want to know more about what's to expect in the coming months and years?

We chose to address that issue from two different perspectives. In his "State of Sales" address, RAB President Gary Fries will review where we've been as an industry and where we're headed in the years to come, while respected trainer Chris Lytle will provide stations with suggested steps they can take today to secure both their station's and their own individual places in tomorrow's rapidly changing radio environment.

It's an exciting time to be in radio, one that's full of opportunities that we'll reap not only today but in the months and years to come. We hope these workshops will give broadcasters the knowledge and ideas they'll need to make the most of them.

Your Listeners Are Ready For RDS/RBDS... Are You?

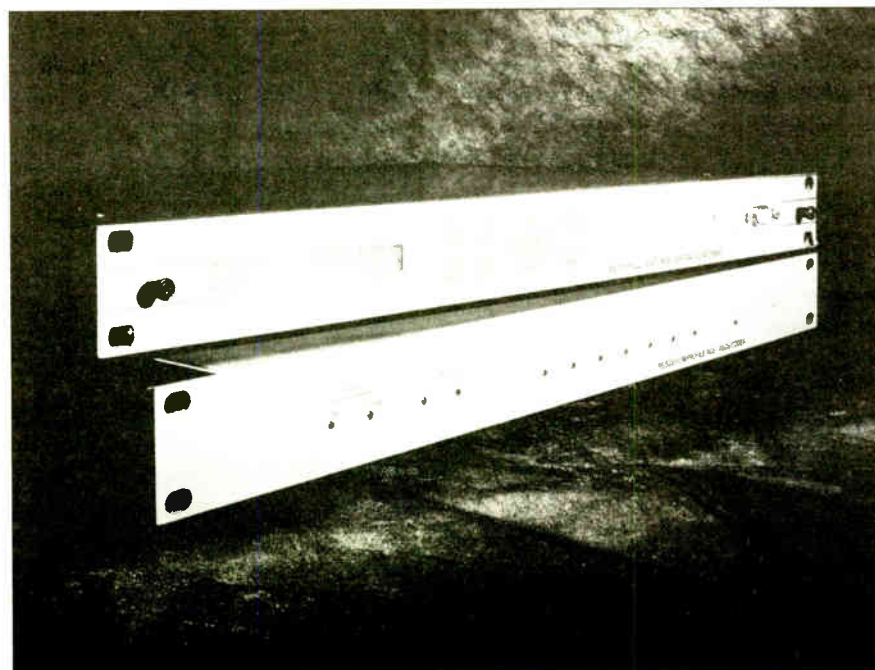

Available through: ▲ Broadcasters General Store ▲ Harris Allied ▲ RF Specialties

This year, RDS/RBDS consumer radios are being purchased by your listening audience, which means the time is right to pursue the revenue opportunities RDS/RBDS has to offer.

RE AMERICA continues its tradition as the leader in RDS/RBDS technology, now with a family of products. Whether you choose the RE 533 for single-user datacasting or the RE 532 for multi-user datacasting, RE has the right encoder to meet your budget and operational needs.

RE takes the risk out of choosing an RDS/RBDS encoder by employing flashprom technology in both the RE 533 and the RE 532. Future upgrades and enhancements are simply downloaded via disc software available from RE. You make the choice, the RE family has got you covered.

RE AMERICA, INC.
31029 Center Ridge Rd.
Westlake, Ohio 44145

Phone: (216) 871-7617 ▲ Fax: (216) 871-4303

Circle (147) On Reader Service Card

Computers Aid Radio Journalists

by Alan Haber

LOS ANGELES You're a radio journalist, and you're in a quandary: the so-called information superhighway is a complex beast, and you have many questions that need answers: "How do I choose the services that are right for me?" "Aren't they hard to use?" "How much will they cost my station?"

In another less technically-oriented and less sophisticated world, these questions might be difficult to answer. However, in this world, there are answers. No matter what kind of information you're seeking, it's probably available, at little or no cost, on the seemingly infinite number of on-line information services available to journalists with only a computer and modem at the ready. Bottom line? You should be on-line, adding depth to and enhancing your stories.

Nora Paul, library director and associate

that "broadcast journalists haven't been taking advantage of the access to information that is out there to the extent that, in a lot of cases, print journalists have." She said her goal for the session is to focus in on "practical and cheap ways to



start tapping into the information" available on bulletin boards, the Internet, and other electronic sources.

In addition to the commercial services, which "require cost," Paul said she wants to talk about services that journalists have "no excuse" not to access, like the Environet bulletin board "that's got fabu-

useful research opportunities. Going online, Paul said, "expands the reach of (journalists) Rolodexes beyond the few names that they've got...It also provides (journalists with) background material and information that educates them before they go to an interview."

If a journalist who prefers to compile information through lots of phone calls and in-person meetings and wonders why anyone would need to access information by computer, this session is still for you. Collecting information by phone can be time-consuming—the phone call is one-to-one communication, Paul said, whereas electronic access is one-to-many.

"In fact, it's one to thousands," she added. Responses to on-line requests for information "can be pretty immediate, within ten, fifteen minute... it's broader and lots of times more efficient."

Paul noted that, in certain cases, searching for information by computer can make the difference between a good story and a great story. "It has been known to happen," she said. "I think it can even change the direction of a story, because it gives you a perspective, and it allows you to go beyond merely reporting an event to quickly putting that event in a context that gives the reporting some depth."

Electronic information sources, available through computer access, are constantly in the news; in other words, there's clearly something going on here you should know about. If you're one of those journalists who has, until now, been held back from going on-line due to budgetary restraints or hardware deficiency, you may well benefit by attending this session. If you already know what the fuss is about, you may just learn something new that will make you even more efficient than you already are. Don't miss this chance to plug in.

The sessions will focus on "practical and cheap ways to start tapping into the information" available on bulletin boards.

of the 20-year-old Poynter Institute, a non-profit education institution which holds training seminars for working journalists in such areas as writing, editing, and media management, is in charge of a session called "Getting Started in Computer Assisted Reporting," being held on Saturday, Oct. 15 from 10:00 a.m.-11:30 a.m. as part of "RTNDA 1994" (check the NAB Daily and convention guides for exact location). Paul herself will be presenting the session along with Valerie Hyman, associate in charge of broadcast seminars for the Poynter Institute; a live demonstration also is planned.

Paul said that a trend she has noticed

lous environmental information, or the AIDS bulletin board in California that's got a library of AIDS information that, you know, you can pay a lot of money going on-line to get."

Paul said discussion will concern "talking about tapping into the expertise of communities of people that are gathering out there in cyberspace and how you can use that for your reporting." In other words, "...a way to go on-line to get to primary sources, rather than just to go on-line to get secondary sources, which has been the way that most people have approached what on-line research is."

Session attendees will learn how going on-line for information can provide new,

DIELECTRIC

FM Antennas

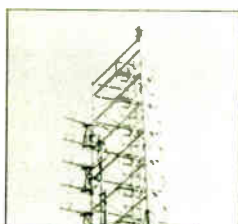

Switches, Loads Custom Systems

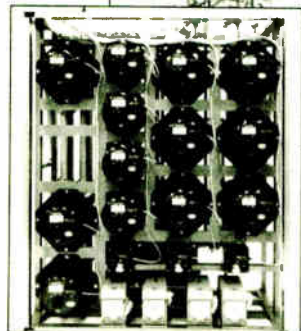

The Dielectric name is recognized worldwide for quality and workmanship in RF communications.

Our products include FM antennas, transmission line, switches, loads, filters, combiners and dehydrator pressurization equipment, everything from transmitter output through the antenna.

Dielectric also designs and manufactures RF equipment for custom applications in addition to our standard television products. Call us with your requirements...

Coaxial Transmission Line



Multistation Combiners



Serving the Radio Broadcaster for Over 45 Years!

Dielectric Communications * P.O. Box 949 * Raymond, Maine USA 04071 * 207-655-4555 * FAX 207-655-7120

Circle (15) On Reader Service Card

World Radio History

Technical Sessions From NAB

by John Marino

LOS ANGELES At the inaugural World Media Expo in Los Angeles, NAB is sponsoring three seminars tailored to radio managers, engineers and technicians. The Management Seminar is taking place on Oct. 11. The Digital Radio Seminar is scheduled for Oct. 13 and the AM Antenna Seminar is a two-day program beginning on Oct. 14.

The Management Seminar

The one-day Management Seminar, on Tuesday October 11, features Roger Herman. Herman, a futurist and management consultant will discuss change in the broadcasting industry. Participants in this seminar will learn how to make change less threatening and manage the change process constructively. The forces of change will be explored: regulations, workforce shifts, organizational structure and downsizing, economic conditions and others.

Practical techniques for dealing with the pressures of change will be explained, so attendees can put their new knowledge to work right away. Learning methods in this seminar include mini-case studies, interactive discussion and individual problem-solving, in addition to lecture.

The Digital Radio Seminar

On Thursday, Oct. 13, managers and engineers learn about digital audio storage, digital audio workstations, the radio local area network (LAN), and the latest news on DAB testing plus DAB system profiles from all the in-band DAB proponents. New technology is explored during a session devoted to "Radio On Demand."

The day-long event begins at 9 a.m. with a tutorial on digital audio. Fred Wylie of Audio Processing Technology will instruct seminar attendees on the basics of analog-to-digital conversion, digital compression, digital storage and digital-to-analog conversion.

Following the 40-minute tutorial session, Skip Pizzi will provide guidance for managers and engineers in selecting and configuring digital storage systems. Radio professionals need to be armed with enough knowledge to intelligently decide if the benefits of digital storage systems will justify the cost.

Later, Jack Williams of Pacific Recorders and Engineering will demystify digital audio workstations and explain how these systems can benefit broadcasters by

continued on page 22 ▶

Some People Think That Radio Production People Are Too Demanding.

NOT TASCAM. Radio and broadcast production demands durable equipment that performs unrelentlessly twenty-four hours a day. That's why you'll find TASCAM equipment in practically every production facility in the country. And that goes for the TASCAM DA-88 modular digital multitrack, as well. It offers you incredible flexibility and a quicker production alternative to elaborate workstations, yet it costs less than a good cart machine. Bottom line is you get the benefits of digital and the ease of use of analog.

No matter how you look at it, the DA-88 is the smartest way to ease into digital production and it's the essential complement to any digital audio workstation. It gives you one hour and forty-eight minutes of crisp digital audio (8-tracks) on a low cost standard Hi8 video tape. Better yet. It works just like any other TASCAM deck — no learning curve. That means hassle free, quick production, especially on those smaller projects with crazy deadlines.

So if you're a demanding broadcast production person, demand the best value in digital multitrack —

THE TASCAM DA-88



DIGITAL DEMANDS

- NO LEARNING! SHOULD ALREADY KNOW HOW TO USE
- LOW COST REMOVABLE MEDIA
- QUICK PRODUCTION USE
- SERVICE & SUPPORT WHEN I NEED IT
- MODULARITY & EASY INTEGRATION
- BUILT TO TAKE A BEATING

TASCAM

Take advantage of our experience

© 1994 TEAC America, Inc. 7331 Telegraph Road, Mission Viejo, CA 92690 (714) 726-8833

Circle (3) On Reader Service Card

World Radio History

Exhibits Packed with New Products

by T. Carter Ross

LOS ANGELES In the past, the conventional wisdom held that the Spring National Association of Broadcasters (NAB) extravaganza in Las Vegas was the place for equipment manufacturers to make a big splash with new equipment.

The dynamics of the 1994 World Media Expo, with the addition of the Society of Motion Picture and Television Engineers (SMPTE), the Radio-Television News Directors Association (RTNDA) and the Society of Broadcast Engineers (SBE) to the NAB show, have been significantly altered. In fact, floor space has grown to 130,000 square feet in 1994; a total of 451 companies have registered for space on the floor this year. These changes have led to a tremendous number of exhibits and many new product introductions a sampling of which follows.

RF field

Under RF equipment, several new transmitters will make a debut at World Media Expo.

Crown Broadcast will show its latest compact solid state FM transmitter, the FM 30. Incorporating the entire chain from processor to exciter to transmitter in one box, the FM 30 is user adjustable for three to 33 W.

Also introducing a compact, programmable transmitter is **Bext** with its Lex 25, which is adjustable from one to 20 W. Bext will also show its SF Series of solid state MOSFET FM amplifiers, from 100 W to 1 kW.

Energy-Onix is showing its new economically priced single-tube ECO FM transmitter, from four to 10 kW. Also new from Energy-Onix are solid state FM transmitters to three kW and a dual-channel 20 kW shortwave transmitter.

Also with new solid state AM and FM gear is **Broadcast Electronics (BE)**. BE will display the AM-500 500 W AM transmitter and the FM-2C 2 kW FM transmitter.

For the UHF band, **ITS Corp.** will introduce the ITS-830, a 1 kW solid state transmitter with broadband amplifiers, high redundancy and many standard features. **Thomson Components and Tubes** will show several new tubes for high-power UHF transmission.

Harris Allied will display a new AES/EBU input to the Harris Digit digi-

source equipment straight through to the transmitter, said to eliminate all A/D-D/A distortion.

Continental Electronics and **CCA** also are expected to show new transmitters.

RBDS applications

For RBDS/RDS applications, **Inovonics** will display an RBDS encoder that can be



Model PRD-3000 Precision RDS/RBDS Decoder/Monitor/Analyzer from Modulation Sciences

operated by computer and an RBDS encoder that can be used with any FM mod monitor to meter injection level and display on all RBDS data and messages.

Modulation Sciences is introducing a whole new family of RBDS/RDS products, including the Model RDS-1 coder, the Model PRD-3000 precision RDS decoder/monitor/analyzer and the RDS-X Series of RDS data receivers.

From **Digital D.J. Inc.** are DDJ Receivers, the

tal FM exciter. The new input makes it possible for broadcasters to operate a 100 percent digital airchain from studio

DDJ Transmission System and DDJ Software. These DDJ products make use of FM subcarrier signal to broadcast high-

speed data messages at 16 kbps on the 76 kHz frequency.

For use a little further down the transmission chain, **Andrew Corp.** will show its 3-inch diameter HRLine rigid transmission line and MT050 dehydrators. **Dielectric Communications** will introduce its Digitline broadband rigid line, RF systems for IOT transmitters and diplexers.

Multichannel FM antennas and combiner systems from **LDL Communications** will make a debut at World Media Expo this year. And **Crown Broadcast** will show its low-power circular polarized antennas.

Shively Labs is introducing its Model 6961 MMDS wireless cable repeater antenna, which reportedly has an extremely low weight and windload, a beam width of 80 to 120 degrees and a standard input power rating of 250 W. The company **S.W.R. Inc.** will also show new MMDS antennas.

To help make certain that everything on-site is working, **ERI-Electronic Research** offers its Site Keeper, a complete tower site monitor, alarm and remote control unit.

Satellite and OB gear

In the outside broadcast (OB) van equipment field, **Will-Burt** will show its electro-mechanical telescoping mast antennas for RENG and ENG use. **Wolf Coach Inc.** will introduce its Power Truck satellite uplink/production vehicle.

There are also a number of satellite-

continued on page 24 ►

Technical Sessions

► continued from page 20

streamlining the time it takes to do production. Even broadcasters in small markets will learn ways to maximize station staff time and create high-quality production. Williams also will show seminar attendees how to choose the right workstation for their facility.

Following a break for lunch, Skip Pizzi will describe the radio LAN and how the LAN concept integrates computerized traffic and billing, programming and engineering functions. The radio LAN has the potential to streamline radio station routine operations and offer broadcasters highly efficient control of the air product.

An exciting new technology will be unveiled by Greg Riker of the Microsoft Corporation. Greg is scheduled to introduce "Radio On Demand." "Radio On Demand," based upon data broadcasting, integrates radio with computers and promises to offer consumers new options for entertainment.

Very little news has been released concerning the DAB testing program presently underway at the NASA Research Center in Cleveland. Tom Keller, DAB test program coordinator, will offer an inside look at the laboratory test procedures and the upcoming DAB system field test objectives.

The in-band DAB proponents, USA Digital Radio, AT&T and Amati will have an opportunity to describe their systems and present an overview of how DAB may eventually benefit broadcasters in the form of higher quality audio and potential data broadcasting opportunities. This session provides a forum for attendees to ask questions and gain insight into the future of DAB and the attendant costs of going digital.

The AM Antenna Seminar

The two-day AM Antenna Seminar begins Friday, Oct. 14 with opening remarks by consulting engineer Carl Smith. The AM Antenna Seminar is one of the very few avenues remaining where broadcasters can learn the theory, operation and maintenance of AM antenna systems. Instructors for the seminar are known around the world as experts in the field of AM antenna design and operation.

Karl Lahm, with the Voice of America, is scheduled to present a tutorial on AM antennas. This important session will set the stage for the following presentations devoted to real-world operational issues such as RF radiation compliance and directional array adjustment.

This year's seminar will also focus on economic considerations for broadcasters contemplating improvements in their antenna systems. The upcoming expanded AM band allocations

offers some broadcasters the opportunity to simulcast an expanded band facility in conjunction with their existing AM station. Questions regarding the cost of diplexing transmitters into a common antenna system will be answered in this session by presenter Tom King of Kintronic Laboratories.

Ron Rackley with the consulting firm of du Treil, Lundin & Rackley will offer alternatives to building an entirely new AM antenna site. In certain situations, broadcasters may be able to share a common antenna site, greatly reducing the cost of a new installation. Rackley will explain how broadcasters can determine if shared sites are a viable option for their stations.

Continuing on the theme of saving money by intelligently considering available options, Jack Sellmeyer, of Sellmeyer Engineering will talk about AM antennas in the age of LMAs and duopolies. There are ways to consolidate the operations of multiple AM sites. Several options will be presented during this session.

Ben Dawson with Hatfield & Dawson will bring attendees up to date with FCC regulatory matters concerning AM antenna systems. Within the past year, the FCC accepted comments in a proceeding questioning whether the AM directional antenna rules, developed over 40 years ago, should be overhauled. The Commission's initial inquiry may lead to a Notice of Proposed Rule Making in the very near future. Dawson will review this FCC initiative and explain how the rules could be changed to take advantage of new methods for verifying the performance of directional arrays. AM broadcasters learn how their participation in this AM proceeding could affect the cost of installing and maintaining AM directional antenna arrays.

Daryl Buechting of the Harris Corporation leads a session on AM DAB. He will explain new modulation methods and the new terminology associated with DAB technology. He will conclude his presentation with a look at the USADR AM DAB system.

The AM Antenna Seminar will conclude with a problem solving forum. In this forum participants talk with the experts about their individual problems.

Overall, the objective of this year's NAB seminars is to offer participants knowledge they can take home with them—knowledge that will allow them to make intelligent decisions on what equipment to purchase or how to solve specific problems.

For more information on the NAB seminars at World Media Expo contact John Marino at NAB (202) 429-5391.

□ □ □

John Marino is director of technical conferences at the NAB. He also can be reached on Internet: jmarino@nab.org.



FM STUDIES

- **SPACING/INTERFERENCE SEARCHES** to locate a channel
- **DETAILED INTERFERENCE STUDIES** optimizing site location and directional antenna designs (calculates allowed ERP on all 360 bearings)
- **TERRAIN ELEVATION RETRIEVAL** determines HAAI for 8 or more radials
- **DISTANCE TO CONTOURS** plots projected coverage
- **POPULATION COUNTING** to determine potential listening audience
- **COVERAGE MAPS AND OVERLAYS** depicts signal coverage, zip code boundaries, received signal level, terrain shadowing and more

dataworld
A Service of DW, Inc.

(301) 652-8822 (800) 368-5754

Circle (134) On Reader Service Card
See Us At WME Booth 1922 & 1924

SONY

GET OUT OF THE SAME OLD LOOP.

Tired of going around and around with your old car machine? Then it's time to head straight for Sony's digital MiniDisc Car. A direct result of Sony's leadership in MiniDisc technology, the MiniDisc Car is a simple plug-in replacement for your NAB car. And it gives you advantages analog simply can't deliver. Like superior sound quality, random access, 16-100 Hz-recordable discs with up to 74 minutes of record time each, and more. Learn how you can get out of the tape loop. Call 1-800-635-SONY ext. MD.

INNOVATION AT WORK.



MD PLAYER MDS-B2P



MD RECORDER MDS-B1

Sony Business and Professional Products Group, 3 Parkside Drive, Manassas, VA 20108-1725. © 1994 Sony Electronics Inc. Reproduction in whole or in part without written permission is prohibited. All other names, marks and the MiniDisc logo are trademarks of Sony.

Products On Display

► continued from page 22

related items making debuts at World Media Expo. **Dawn Satellite** is introducing digital audio receivers and digital-



Telos Zephyr Digital Network Audio Transceiver

ready LNB amplifiers for use with them, as well as Coversat, a satellite antenna snow cover. Harris Allied will offer its DSE 1400 digital satellite exciter and

DSR 1400 studio-grade receiver, a digital SNG system that uses MPEG Layer II compression to provide access to a greater range of transponder channels, reduced transponder costs and more.

New from **Wegener Communications** is the DVR Series of MPEG digital video product family, including encoders, decoders and satellite integrated receiver decoders (IRD). **International Datacasting Communications (IDC)** will present its BPSK



NEC America's MLink-500

FlexRoute audio/data receiver for multi-channel digital audio or mixed audio/data applications. The BPSK FlexRoute facilitates the use of low-cost DRO LNBs.

ComStream will display new high-volume receivers for delivering more than 100 channels of compressed video or audio directly to the user, at home or work.

TFT Inc. is introducing the DSS93 digital subcarrier system for TV microwave and satellite applications.

Program control equipment

Crown Broadcast and **StandardNews Radio Network** both are showing satellite network program control equipment. StandardNews' system, daX, is PC-based and is designed to provide control of network audio, data, news and information feeds.

For personal communications, **NEC America** offers its MLink-5000 briefcase satellite terminal, a self-contained, lightweight personal satellite terminal. It provides worldwide voice and fax communications, with data communications capabilities to be added soon.

Moving back to planet's surface, several new pieces of telco, STL and codec technology will be shown at World Media Expo.

Moseley Associates will display its StarLink 9000 all-digital modular system for simplex/duplex transmission, which won a Cool Stuff Award (CSA) from RW at the Spring NAB show in Las Vegas; the new DSP6000 options for ISO/MPEG source code and a built-in AES/EBU converter; and the MRC 2 programmable intelligent co-processor module interface option for **Tektronix** video analyzer, satellite controllers and video/audio switchers.

The Model STL-15C composite STL system from **Marti Electronics** will display new capabilities, including options for use at international frequencies.

At the **Bradley Broadcast Sales** booth, World Media Expo attendees can see the **QEI Quick-Link RPU** system, a digital stereo microwave system, which also won a CSA at NAB '94.

Bradley Broadcast will also show the **Telos Zephyr** digital transceiver, which is capable of transmitting bi-directional 15 kHz stereo audio via a single ISDN line. Telos will maintain its own booth where the CSA-winning Zephyr is also on display.

Codec technology

Also showing new codec technology is **AEQ-America Inc.** AEQ's ADC-3000 is a multiformat digital audio codec with both ISO/MPEG Layer II and CCITT G.722 capabilities.

New from **CCS Audio Products** are the Ultima and Prima digital audio codecs, which are part of a fully integrated 20 kHz stereo codec system. **Comrex Corp.** will introduce its DX100 apt-X digital audio coder and the DX200 ISO/MPEG Layer II digital audio codec.

Audio Precision Inc. will display on-site test results of reduced-bit rate coder systems tested with Audio Precision's new System One audio test's Coder.DSP software.

At both its own booth and at Harris Allied's, **Gentner** will show its TS612 DCT Multiline telephone system, designed for fast-paced broadcast use. The DCT system also won a CSA at the Spring show.

For Emergency Broadcast System (EBS) continued on page 27 ►

The Dolby DSTL® has always been known for great specs.

Here's another.



If you shop for equipment by the numbers, there's one more you can't ignore: the new, competitive price of the Dolby Digital Studio Transmitter Link. You already know the DSTL can't be beat when it comes to performance. But the latest developments in its RF design let us lower prices without compromising its robust, interference-free operation and high quality audio.

Call us today to find out more at **800-DOLBY-RF (365-2973)**. Our numbers will make both you and your bottom line happy.

*Suggested list price of the two channel system. Suggested list price of the four channel system including the optional digital stereo generator is \$14,900. Contact your local distributor for actual prices. For those of you who read the fine print, you'll be glad to know that you can order the two channel DSTL with our new AES/EBU digital input at no additional charge. It's also available to retrofit to existing 2-channel DSTL systems. We're doing our part to make the all-digital signal path a reality!

Dolby Laboratories Inc. • 100 Potrero Avenue, San Francisco, CA 94103-4813 • Telephone 415-558-0200 • Facsimile 415-863-1373
Dolby Laboratories Inc. • Wootton Bassett • Wiltshire SN4 8QJ • England • Telephone 0793-842100 • Facsimile 0793-842101 • Telex 44849
Dolby, DSTL and the double-D symbol are trademarks of Dolby Laboratories Licensing Corporation ©1994 Dolby Laboratories Inc. 594/10339



Circle (96) On Reader Service Card

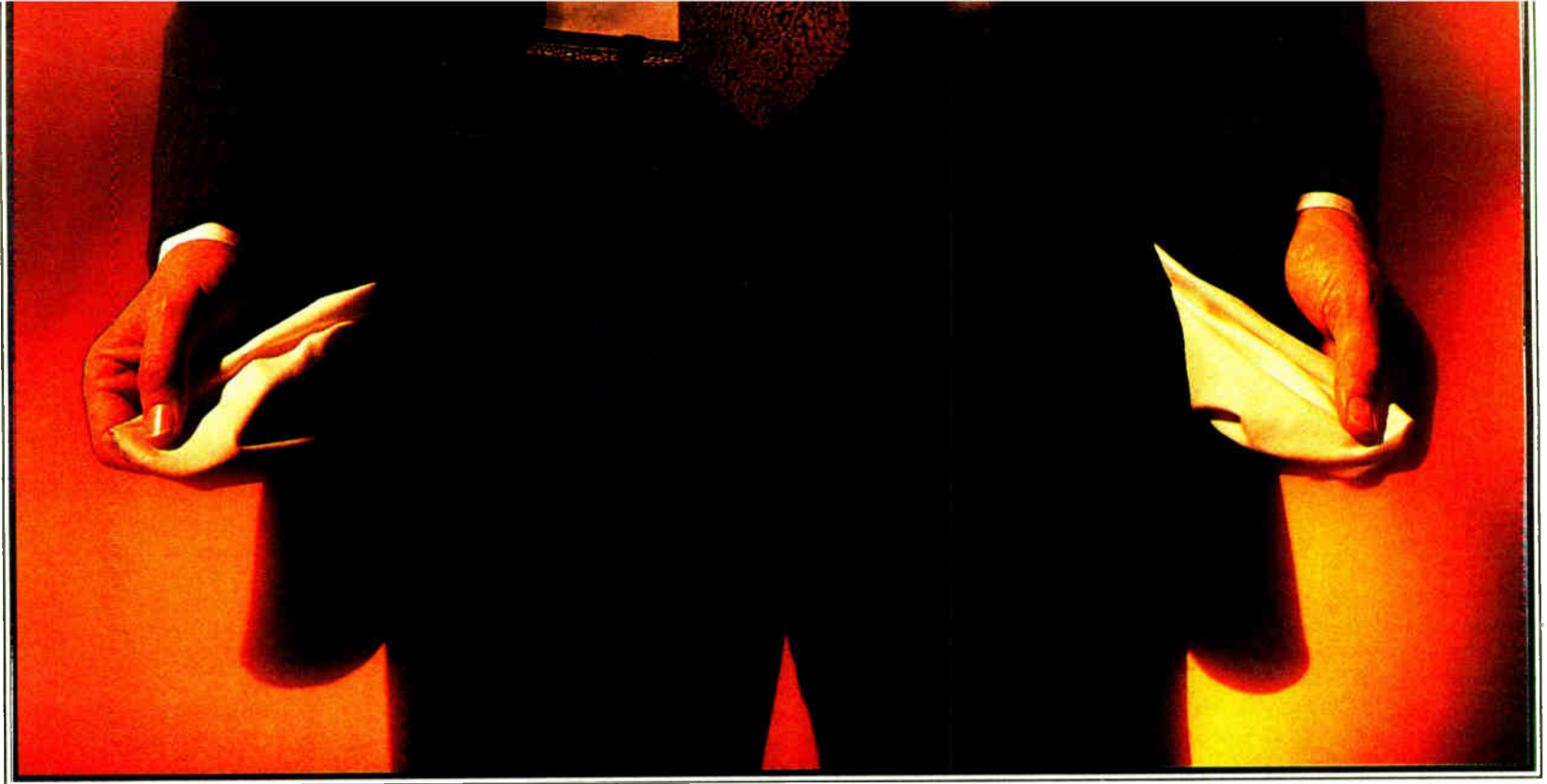

**Why so many TIGHTFISTED
Penny-pinching
FM stations are willing to dig
deeper for an OPTIMOD.**

Seems everyone has gotten a little tighter, and more savvy, since the recession. To attract and hold a wider audience, stations have learned to invest in what keeps working. Like better programming. And pure digital sound.

With all-digital processing, the OPTIMOD 8200 delivers what no analog

FM processor can: the unmistakable punch and clarity of "the OPTIMOD sound," with the power and flexibility of four built-in



digital processors. So you can tailor your station's sound precisely to your format. Add new sounds simply by adding a new board. And never have to worry about outgrowing, or unloading, a capital investment.

The 8200 frees you to go wherever digital FM goes. While analog boxes only dig you in deeper.

orban[®]

H A Harman International Company

1525 Alvarado St., San Leandro, CA 94577 USA Phone 1•510•351•3500 Fax 1•510•351•0500.

© 1994 AKG Acoustics, Inc. Orban and OPTIMOD are registered trademarks of AKG Acoustics, Inc. All other trademarks are property of their respective companies.

Circle (86) On Reader Service Card

See Us At WME Booth 2806

World Radio History

OVER
5 MINUTES
OF 15KHZ STEREO AUDIO
ON EACH 13MB FLOPPY DISC



The Dynamax DCR1000 with New Version 2.0 Software

THE OBVIOUS DIGITAL SOLUTION TO CART MACHINE PLUG-IN REPLACEMENT

The Recorder

- Selectable sampling rates
- Secondary and Tertiary cues
- AES/EBU digital input
- Start on audio
- Direct digital dubbing from CD
- PC keyboard for titling
- New* • Cut & paste editing
- New* • Variable length beds
- New* • Kill date checking
- New* • Disk label printing

The Reproducer

- Simple cart-like operation
- No on-air personality training
- Just three front panel buttons
- Instant start and cue
- Maintenance-free design
- Awesome audio quality
- New* • Rotation & chaining
- New* • Replay lockout
- New* • Count-up/count-down timer
- New* • RS232 logging/remote control

The Media

- 13MB stores over 5 minutes stereo audio with 15kHz bandwidth and 15 minutes mono with 10kHz
- Standard low-cost 2MB floppy disk holds 60-second commercials
- New* • Non destructive media diagnostic test

Special Offer!

FREE Record Module with purchase of 3 players

Equipment Solutions To Keep You Number One

BSW
BROADCAST SUPPLY WORLDWIDE

Toll Free 800-426-8434

Toll Free Fax 800-231-7055

New, Existing Products

► continued from page 24

applications. TFT will show its new EIS 991 and 912 new technology EBS code generators and detectors as well as the EIS 930 multichannel receiver.

To help keep the airchain sounding pristine, several new audio processing features and products are appearing at the show.

Cutting Edge will exhibit its Unity AM and Unity 2000i FM processors and the VIP-1 programmable voice processor. Also new from Cutting Edge is the Unity Remote Software, which enables complete transmitter processing control from anywhere.

Also with new remote software is **Orban** with PC-based remote software for its 8200 Digital Optimod-FM.

Aphex Systems will introduce its Models 320A and 323A compellers and the Model 722 Dominator II multiband peak limiter. Also new from Aphex is the Model 107 Tubessence two-channel vacuum tube mic preamp.

Studio processors

Among the new studio processors is the **Alesis QuadraVerb 2 (Q2)**. The Q2 provides eight simultaneous effects to be combined, layered or split between two

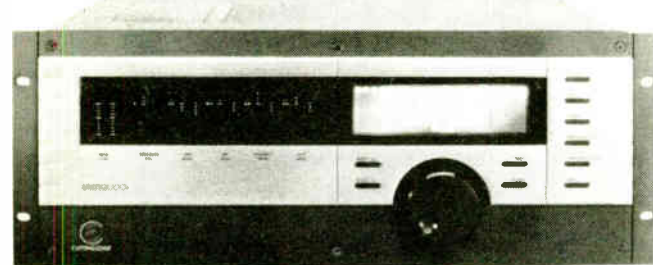

Cutting Edge Unity 2000i Processor

input and two output channels.

Eventide is showing the new H3000-B+ and H3000-B/LT Ultra-Harmonizer effects processors, and **Panasonic Broadcast & Television** is introducing a new multi-audio processor. **Jensen Transformers** offers the 68JT upgrade kit for the Magna-Tech 68B/68C record amplifiers.

The **NVISION** digital audio processing suite, also new at the show, provides a full array of processing tools in four rack units. It includes an NV1055 four-channel sample rate converter, an NV1060 digital audio delay compensator, NV1050 four-channel sample rate converter and two NV1308 8x8 routers, remote control panels and a power supply.

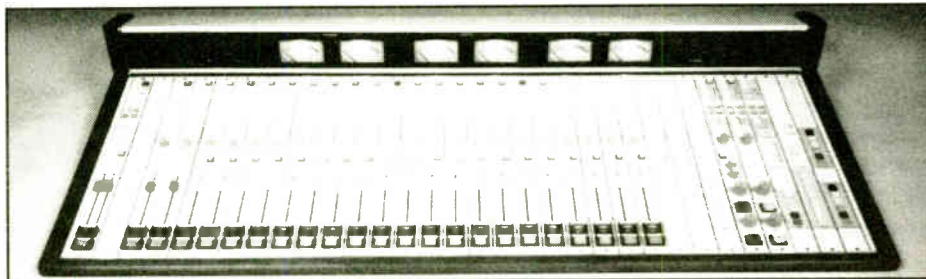

Wheatstone A-6000

New studio source gear will also make debuts at World Media Expo. **Otari Corp.** is showing its MR-10 MiniDisc recorder/player and the CDC-600, a 350-disc capacity, dual-drive CD autochanger. Also new from Otari is RADAR, an eight-, 16- or 24-track random access digital audio recorder.

Offering a new alternative to the ubiquitous NAB cart is **Radio Systems** with its DDS hard disk audio "cart" machine. Similarly, **Fidelipac Corp.** offers its 230MB magneto-optical (MO) drive and additional software for its DCR1000 Series cart replacement machine.

Also showing source gear are **Denon America**, with its full line of MiniDisc and CD equipment, and **Pioneer New Media Technologies**.

Wireless mic system

Telex Communications will introduce its FMR-450 UHF wireless microphone system as well as the BP-1000 and 2000

beltpack headset station. Also new on display are a the matrix keypad and a desk-mount keypad.

To route audio through the studio, several new consoles, studio components, furniture designs and cabling options are on display at this year's show.

Wheatstone Corp. is introducing the A-6000 master air console with totally flexible architecture and comprehensive built-in logic and audio programming features.

The SDA-84000 distribution amplifier

(DA) is being exhibited by **Audioarts Engineering**, as is the R-10 console.

New from **Logitek** is the Crossfire II 12-channel ESAM-controlled audio



Telex Audiocom BP-1000 and BP-2000 Belt Pack Stations

mixer and the Mini RateGate low-cost digital audio sample rate converter.

Otari offers its STATUS digitally

controlled analog recording and production console as well as the B-10 audio mixing console for broadcast applications.

New modules available from **Fidelipac** for the MXE console include microphone EQ, talkback/studio monitor and a telephone hybrid interface.

Consoles and furniture

Arrakis Systems offers both new consoles and new furniture. The Gemini live digital audio workstation/mixing console and the 1200 Series consoles will be on display as will Desk*Star custom studio furniture.

Audio Technologies Inc. (ATI) will present its NanoAmp Series MX100, a three-input mic/line mixer with companion XP100 four-input expander.

continued on page 29 ►

FM ANTENNAS

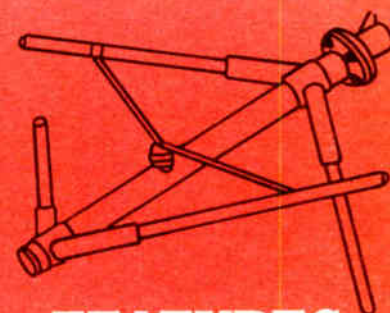

FEATURES

Multi-Element Arrays

Input Powers from 100W to 240 kW

Circular, Vertical, or Horizontal Polarization

Custom Directional Antennas

Quality Construction Built to Last



Systems With Reliability

1-800-762-7743

Systems With Reliability

Transmission Lines & Antennas Celebrating Our 25th Year

Cambria County Industrial Park Ebensburg, Pa. 15931-0856 Fax: 814-472-5552

Circle (212) On Reader Service Card

A2

Audio Test System

Bit-Analyzer
Jitter-Analyzer
D/A Converter
AES/EBU Generator

14 Instruments in one

- easy to operate
- storage capabilities
- highest performance
- large graphics display

AS03 software-package for remote-control and automatic tests

- comprehensive two-channel system
- PC-and printer communication

NEUTRIK
CONNECTING THE WORLD

The leading instrument

Neutrik AG Liechtenstein Tel: 075/232966 Fax: 075/2325393
 Neutrik Zürich AG Switzerland Tel: 01/7340400 Fax: 01/7343891
 NCV GmbH Germany Tel: 0941/98041 Fax: 0941/999772
 Neutrik Marketing Ltd United Kingdom Tel: 071/7928188 Fax: 071/7928187
 Neutrik Division of Japan Japan Tel: 03/54112551 Fax: 03/54112827
 Neutrik Instrumentation Canada/USA Tel: 514/3445220 Fax: 514/3445221
 800-661-6388

Circle (10) On Reader Service Card

Products & Services Showcase

For more information on the products shown below, circle the appropriate Reader Service No. (s) on the enclosed Subscription/Reader Service card or contact the advertiser directly.

S.C.M.S., Inc. Charlotte, N.C.

Low Prices – Experienced Staff
New and Re-built R.F. and Audio

THIS MONTH'S SPECIAL

FALL SPORTS MIXERS

MACKIE	#1202	\$284.00
SHURE	#M-267	\$389.00
ZERCOM	#MAX-Z	\$1,085.00

Toll-Free 800-438-6040

FAX 704-889-4540

READER SERVICE NO. 12

EXPANDABILITY

Expandable Digital Remote Control.

As your station metering requirements grow to additional sites and channels, the DRC 190 from Hallikainen & Friends grows with you. By its inherent, modular-expansion design, the DRC 190 can accommodate a single transmitter or grow to manage up to 100. Reliable firmware includes a multiple access, anti-contention data packet system allowing any site to communicate with any other site over wire-line, sub-carrier or half-duplex UHF radio. The same firmware allows expanding the system by adding additional sites or channels at any time. For a system to grow with, not out of, expand with the DRC 190.

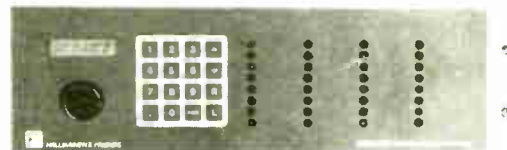

PROGRAMMABLE EXPANDABLE AFFORDABLE DRC 190

HALLIKAINEN & FRIENDS

141 Suburban E4, San Luis Obispo, CA 93401-7590 USA
805-541-0200

READER SERVICE NO. 45



MADE
IN
U.S.A.

I HAVE TO DRIVE TO
THE TRANSMITTER?
... AGAIN ?!?!

Why drive when you can call? Using Monroe's 6000 Series Remote Controls and your telephone, two-way radio, microwave link or other audio path you can have complete control over a remote site. For over 15 years Monroe Electronics has supplied the broadcast industry with reliable and affordable DTMF remote control systems.

Let us help reduce your driving time, call Monroe Electronics today.

Distributor and Representative inquiries invited.

ME MONROE ELECTRONICS

800 821 6001
716 765 2254
FAX 716 765 9330

LYNDONVILLE, NY 14098

FAX 716 765 9330

READER SERVICE NO. 5

The CircuitWerkes DTMF-16 TouchTone Decoder



Inexpensive & Convenient Control

- Decodes all 16 DTMF tones.
- Bridging input & high current opto-isolated outputs.
- Jumper selectable beep-tone acknowledges commands.
- Momentary or Interlocked Latching output modes.
- New, two tone decoder & anti-falsing filter improve reliability & versatility.
- Combine with an AC-2 auto-coupler for an economical dial-up remote control.

The DTMF-16 is perfect for interfacing networks to your automation, controlling remote satellite receivers, repeaters, etc. With a list price of only \$199, the compact, light & rugged DTMF-16 can be put almost anywhere to provide the remote controls that you need. For more info, contact your favorite broadcast supplier or call us.

CircuitWerkes

6212 SW 8th Place
Gainesville, Florida 32607
(904) 331-5999 / Fax 331-6999



READER SERVICE NO. 95

ERI - Trusted since 1943
for Proven Performance in

ANTENNA - FILTER
 λ (lambda) MOUNTING
TOWER - INSTALLATION

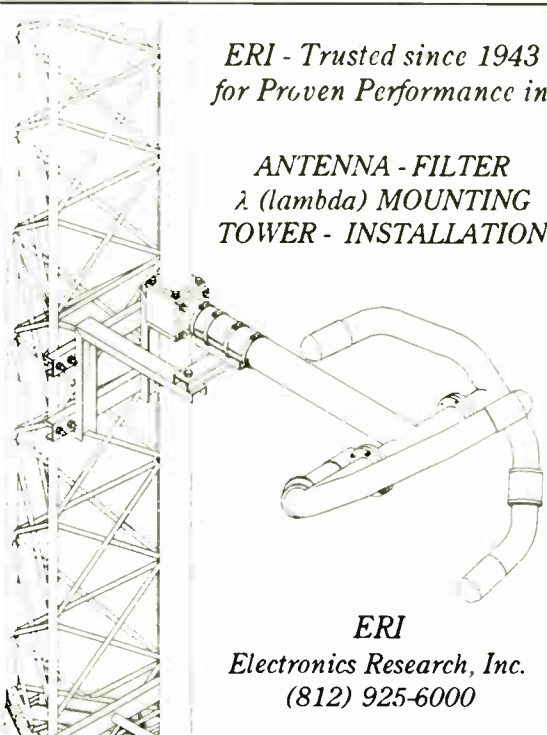

ERI

Electronics Research, Inc.
(812) 925-6000

READER SERVICE NO. 2



A-7550...10 kHz to 1 GHz PORTABLE SPECTRUM ANALYZER

Synthesized tuning and phase locked frequency stabilization enable accurate swept frequency measurements over calibrated span widths from as wide as 100 MHz/div to as narrow as 1 kHz/div. A standard 300 Hz resolution bandwidth filter and peak hold mode provide NRSC measurement capability. Other A-7550 features include:

- +30 to -120 dBm measurement range
- DC operation from 12 to 30 volts (Built-in battery optional)
- Optional built-in tracking generator
- Optional built-in AM/FM/SSB receiver
- Optional IEEE-488 or RS-232 interfaces.

For more information or a demonstration of the A-7550 contact:

IFR SYSTEMS, INC.

10200 West York St., Wichita, Kansas 67215
Phone (316) 522-4981 Ext. 207. FAX (316) 524-2623
DIRECT FACTORY RENTAL PLAN AVAILABLE



READER SERVICE NO. 177

NEW!!! from AVCOM PSA-65A Portable Spectrum Analyzer & SCPC-2000E Single Channel Per Carrier Receiver



PSA-65A Portable Spectrum Analyzer - \$2855

AVCOM's PSA-65A Portable Microwave Spectrum Analyzer covers a frequency range from less than 2 MHz to 1000 MHz. The broad frequency coverage and high sensitivity of the PSA-65A make it ideal wherever a low cost, compact spectrum analyzer is needed. The light weight, battery or line operated PSA-65A Portable Spectrum Analyzer from AVCOM is the perfect instrument for field testing of RF systems, classroom instruction, satellite system alignment, electronic countermeasures, cable TV maintenance, cellular and production use.



SCPC-2000E SCPC Satellite Receiver - \$1875

AVCOM's Single Channel Per Carrier Receiver, model SCPC-2000E, has been developed for the reception of FM SCPC signals from satellites operating in the 3.7 to 4.2 GHz band. The SCPC-2000E is a complete receiver that can tune up to 4 specific crystal controlled audio or data channels from a given transponder and adapt to a variety of de-emphasis requirements. The SCPC-2000E is available in either wide or narrow band models and may be used with the SS-1000 (\$1027) Slave for simultaneous reception of additional channels.

AVCOM OF VIRGINIA 500 Southlake Blvd. Richmond, VA 23236 U.S.A.
Bringing High Technology Down to Earth Phone 804-794-2500 / Fax 804-794-8284

READER SERVICE NO. 14

Custom!

Shively FM Antennas offer standard features often unique in the industry: Custom-designed stainless steel mounts, included as standard equipment on Shively commercial antennas, ensure a secure and exact interface between the antenna and its support structure. Unlike others who use pieces of chain and "J-bolts", Shively's custom approach assures you of an installation that goes together right the first time, with a minimum of rigging time, and stays that way! Watch future issues of *Radio World* for other unique Shively features.

Shively Labs

A Division of Howell Laboratories, Inc.

19 Harrison Road, Bridgton, ME 04009
207-647-3327 FAX 207-647-8273

READER SERVICE NO. 91

THIS SHORTWAVE RADIO COULD BE YOURS ...FREE!



Step 1: Visit Bradley Broadcast at Booth 2922 in L.A.

Step 2: Register to win this serious world radio. Value: \$389.95!

Step 3: See important new equipment for broadcasters including Telos Zephyr, QEI Quick Link, Sony MiniDisc, and more!

Bradley Broadcast Always call Bradley
1-800-732-7665

Tel: 301-948-0650 Fax: 301-330-7198
8101 Cossna Avenue, Gaithersburg, MD 20879

READER SERVICE NO. 60

Latest Radio Products

► continued from page 27

For audio distribution, **Benchmark Media Systems Inc.** will introduce DA-102DM audio DA as well as the Audioworld Interface. The Audioworld combines a two-way recorder interface with switch-selectable operation as a line amplifier or mono mix amplifier.

The Management will introduce a DMX-4B stereo audio switcher on an IBM PC card. It includes eight logic I/O, balanced stereo and summed mono audio out.

Ramko Research will display its new

59/U triax cable with stranded center conductor.

The world's smallest 3-pin XLR connector will make its debut at the show. **Neutrik U.S.A.** will show the Nanocom, which features unique chuck-type strain relief, lockable latch release, machine gold-plated contacts and rugged machine metal housings. Neutrik also will show a miniature connector, the Minicon, that uses up to 12 contacts.

Test gear

Making certain state-of-the-art equipment stays in top shape requires up-to-date equipment. World Media Expo will see several

new introductions in this area as well.

Belar Electronics Lab will present its FMSA-1 FM digital stereo monitor/analyzer and an RBDS/RDS monitor.

Radio Design Labs (RDL) will show its ST-OSC2 A/B audio oscillators, ST-SX4 4x1 audio switch, RLC remote

auto-null THD, frequency counter, IMB, stereo phase and ratio, will be shown too.

Wireworks Corp. will show its TE-3+ cable tester for XLR, TRS and BNC cable assemblies. Also on display are XLR I/O microphone splitters, Neutrik Speakon-terminated speaker cable assemblies and TEN-4 speaker cable testers.

To monitor SurroundSound encoded programming, **Wohler Technologies** offers its new SurroundSound Monitor, a 2-RU high unit that decodes Surround-encoded programs for continuous aural monitoring of all channels.

Both **Logitek** and **Dorrrough** continued on page 30 ►



Wohler Technologies SurroundSound Monitor

level controller and the ST-RG1 digital DC ramp generator.

The AA-51A from **Potomac Instruments**, which features balanced inputs,

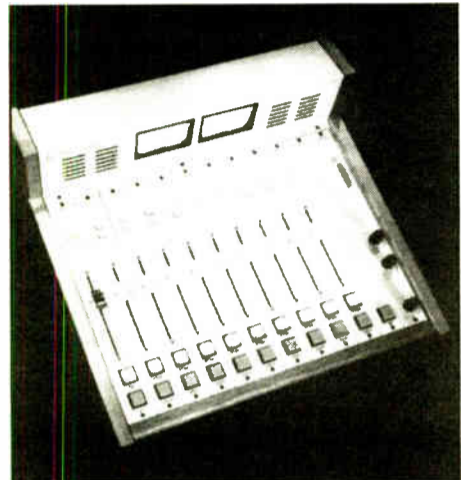

Audioarts R-10

ProMod ultra miniature audio/video/digital modules. The Series includes DAs, audio amps, signal processor and more. Also from Ramko are ProMax programmable audio modules.

Panasonic Broadcast will show its A5-D740 digital component switcher.

Acoustical Solutions Inc. will present its AlphaSorb wall panels and hanging baffles and Audio Seal Sound Barrier, a dense limp-mass vinyl barrier that blocks up to 27 dB of sound. A prefabricated modular recording booth that blocks 47 dB of sounds will also be on display.

Set design

Broadcast Design International will show several of its recent set design projects, and **Winsted Corp.** will display multimedia furniture featuring a recessed monitor well for ergonomic viewing.

Clark Wire & Cable is introducing ADC True 75-ohm BNC for serial digital coax, RCC1V3AH remote composite cable and Complex II extended distance RG11-style coax cable.

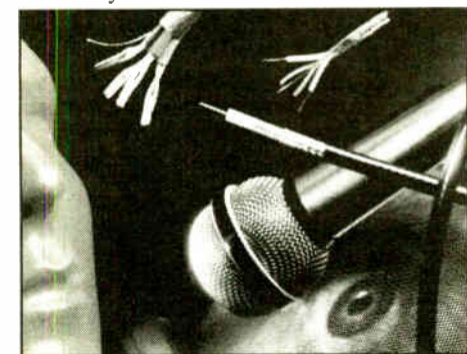

Belden Mini Star Mic Cable

Also showing new cables is **Belden Wire & Cable** with single- and multi-pair 110-ohm digital audio cables and Mini Star Quad mic cables. **Nemal Electronics** will introduce a line of flexible composite cables that include audio, video and power under a single jacket.

Gecco International will present 10 different color conductors of the original VPM2000 cables with an overall jacket. Also new from Gecco is LVT61859S, a

Any microphone can be wireless



3 different ways.

Now there are 3 different systems to meet your specific needs...



VHF narrow band:

The industry standard VHF plug-on version works with the CR185 receiver for day to day ENG use.

This system has been the basic workhorse companion of ENG crews since 1988. With over 12,000 of these systems in the field, it's no wonder you see them everywhere. The ruggedness and reliability of this system speak for themselves.



UHF narrow band:

The UCR190 receiver is an updated UHF version aimed at broadcast ENG applications.

Increased operating range, improved signal to noise ratio and lower distortion are the most obvious differences in the 190 Series over its VHF counterpart. The 190 Series UHF systems typically exhibit 2 to 3 times the operating range of the VHF systems, due mostly to antenna efficiency. The addition of the Lectrosonics exclusive dual-band compandor provides the noticeable improvement in audio quality.

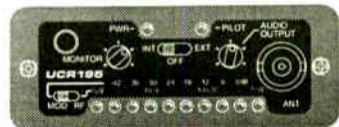

UHF wide band:

The 195 Series UHF systems set the new standard for the state of the art in wireless systems, with high definition audio quality and full function metering.

Using +/- 75 KHz deviation, dual-band companding, a digital pulse counting detector, full RF and audio metering, and balanced XLR output from -50dBm to +8dBm, the UCR195 receiver clearly sets the standard at the high end of the market. The compact size is convenient for camera mounted applications, yet the performance is well suited to the most demanding studio environments.

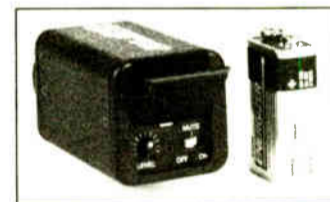

All 3 models operate on a single 9 Volt alkaline battery and provide a wide range level control which adjusts from mic to line levels.

Since 1988, Lectrosonics has led the broadcast market by introducing innovative wireless products to solve day to day problems. The plug-on transmitter is only one example of these innovative efforts.

All broadcast and professional wireless products are constructed of machined aluminum, designed and manufactured in the Lectrosonics facility. The latest computerized machining equipment is utilized to maintain the highest standards for precision.

The newest fully automatic surface mount equipment is used to assemble circuit boards, providing a final product that is as rugged and dependable as it is attractive.

**Call for more information:
800-821-1121**

Ask for a free copy of the 50 page Wireless Guide when you call!



LECTROSONICS

581 Laser Road, Rio Rancho, NM 87124 USA - Phone: (505) 892-4501 - FAX: (505) 892-6243

Circle (27) On Reader Service Card

No Shortage of PC-Based Radio Gear

LOS ANGELES While RF, satellite and studio gear constitute a large percentage of the floor space at World Media Expo, there are also a number of computer-based and computer-related products for broadcasters being shown at this year's exposition.

Ranging from digital audio workstations (DAW) and hard disk-based audio playback systems to news/control room automation systems and management software packages, there are certain to be computer solutions to suit every broadcaster's needs.

Automation systems

Perhaps the most pervasive use of computers in radio today is with automation systems. A number of new automation systems and features will make debuts at World Media Expo.

Arrakis Systems will exhibit 15 new features for its DigiLink, including auto trim of audio files, tagged text for CD tracks and hard disk audio files, start and kill dates and automatic time announce. Arrakis will also show new features for the Track*Star 8 digital multitrack editor.

The Master Control Automation system will be introduced by **Columbine Systems Inc.** It features fully automated airing of scheduled events, including spots, programs, local productions and public service announcements (PSA).

New from **SMARTS Broadcast Systems** is the Generation 2000 Digital Audio Network. A networked series of computer nodes, the Generation 2000 is capable of performing multiple simultaneous operations, including record and play back, overlap of audio and schedule programming.

Scott Studios Corp. offers a new Scott System for automating news/talk/sports stations. It features console control, interface to the newsroom, wall of carts and unlimited access to digital audio.

The NetStation for Windows, a PC workstation with an intuitive graphical user interface and a built-in archive interface will be shown by **BASYS Automation Systems**. The **Australian Broadcasting**

Corp. will show its D-Radio digital on-air radio system.

Hard disk sampler

360 Systems will introduce its HR550 Hard Disk Sampler, a professional digital audio recorder. Also new from 360 Systems is OnScreen/II, a software program for DigiCart/II, and an AES/EBU interface for DigiCart/II.

Also new is the Pick N' Play digital audio cart replacement system from **Media-Touch Systems**. On display with Pick N' Play is the DDI dumb device interface for interconnecting and automating outboard machines.

Pristine Systems will introduce the Drop Box, a hard disk system that allows instant playback of up to 26 hard disk audio files. And to computerize newsrooms with digital audio, **Radio Computing Services (RCS)** offers the RCS NewsLink.

The CacheMachine, new from **Odetics Broadcast**, is a digital hard disk-based system that plays spots directly to air while storing program materials and spots to tape. **CBSI/Custom Business Systems Inc.** will show its PowerPlus System and the Digital Universe digital audio system.

For automating weather reports, **Weatheradio** offers the Digital Weatherman II, a computer-based automation system providing 24-hour walk-away weather bulletins. Also offering new weather services is **Accu-Weather Inc.**, which will exhibit UltraGraphix-32 Weather System.

IDB will introduce its Telespot service, a spot commercial delivery service offering digitized spots and instructions sent via IDB's Switched 56 equipment.

Digital domain

For editing audio in the digital domain, DAWs have become essential. Some are specially designed for use in the broadcast suite while others are highly sophisticated production tools.

The French company **Dalet**, who is represented in the U.S. by **R.F. Specialties**,

will introduce an easy-to-use multitrack with unlimited virtual tracks.

Orban will display several new features and a lower price on its DSE7000 digital sound editor. Also for the DSE7000, **Harris Allied** will show a digital I/O that allows it to keep production entirely in the digital domain.

Introducing the latest version of its digital audio editor software is **SADiE Inc.** The software, includes alternative backup to match the faster Exabyte 8mm system, hardware controller interface, direct SCSI CD-R creation to Red Book standard and DDP CD-mastering format on Exabyte 8mm tape.

Pacific Recorders & Engineering (PR&E) will show its ADX Basic, a desktop version of the ADX WorkStation that is expandable to WorkStation or Mix-Station systems.

Also, **Scott Studios** will introduce a new graphical waveform digital audio editor and **Broadcast Supply Worldwide (BSW)** will show the ProVox digital audio recorder.

Production work

For production work, **FirstCom Broadcast Service** will offer MusiQuick search and select software to help locate tracks for promos and commercials. **Killer Tracks** will offer a new self-editing software package, Tune-Builders by AirWorks, that works with Killer Tracks and the B146 scoring library.

Network Music Inc. will show its Trackfinder CD-ROM catalog. It can be used to audition a 29-second sample of any theme in the Network Production Music Library at the click of a mouse.

Also branching into CD-ROM, **TM Century Inc.** will show its playback CD-ROM production library. **Valentino** offers production music and sound effects libraries on CD and CD-ROM too.

For account management, **CBSI** will show its Custom Reports and Design Financial Reports packages.

Computer Concepts Corp. will show

Visual Traffic (VT), a Windows-based graphical system for account management, sales maintenance, commissions and goals, log maintenance, copy and script management, report, and accounts receivable.

Ratings analysis

New from **TapSCAN Inc.** is TapSCAN for Windows ratings analysis system; Prospector business and sales research information; County Coverage Research System; and SalesSCAN sales history management system.

The Maximi\$er from **Arbitron** is also being introduced. It is a PC-based system providing access to the respondent level database of Arbitron's syndicated local market radio audience service.

Dataworld will show a variety of its computer services, including extensive ethnic/demographic data reporting, detailed mapping and business profiles.

ScheduALL by VisuALL Inc. will exhibit its Personnel Manager with new timecard and payroll support features. **Strata Marketing** will introduce AXIS, a systemwide integration management service.

To connect networks, **Pacific Radio Electronics** is introducing Unicom local area network (LAN) products.

Products On Display

► continued from page 29

Electronics will introduce new audio level meters. Look for the Ultra-VU expanded range LED audio meter from Logitek and an AES/EBU audio level meter from Dorrrough.

To keep power situations stable, **Superior Electric** offers its Stabiline SL Series of uninterruptible power supply (UPS) systems and line interactive UPS systems.

Programming and services

Among the new programming and services offered at World Media Expo are AP All News Radio, a live 24-hour turnkey network from **Associated Press** and **Bloomberg News Radio** from **Bloomberg Financial**.

Network Music Inc. will introduce a 15-CD collection of 130-plus famous classic themes in both broadcast edit and full-length versions. For contemporary musical tastes, **Toby Arnold & Assoc.** will show its Attitude II music library, Lifestyles full-service AC library and the Fun Radio music library with CHR, Hot AC and urban sweepers.

TM Century will offer a new service, television campaigns to promote radio stations. **RadioVision Inc.** also will introduce 3-D animation and TV spot production services for promoting radio stations.

Omnia Group Inc. will spotlight its new workshops designed for the broadcast industry to help improve sales and management performance and ability.

And for those who need reference guides and instruction books for production and broadcasting, **Focal Press** will introduce several new titles, including *The Art of Data Recording* and *An Introduction to Digital Audio*, both by John Watkinson and *Sound and Recording*, second edition, by Francis Rumsey and Tim McCormick.

MAKE YOUR HIGH COSTS DISAPPEAR.

Wizard For Windows™
by Prophet Systems, Inc.

The **Flexible** Digital Automation System featuring Windows and Novell Network Technology

- RUNS MULTIPLE STATIONS
- DIGITAL REAL-TIME EDITOR
- HARD DRIVE AUTOMATION
- INTEGRATED COPY SYSTEM
- VOICE TRACKING with LEVEL CONTROL
- SIMULTANEOUS RECORD and PLAY
- EXPANDABLE FROM 2-20 TERMINALS
- AUTOMATIC BLOCK STRETCH/SQUEEZE
- DIGITAL REEL-REEL RECORD SYSTEM
- SATELLITE, MANUAL, or AUTO MODES
- INSTANT ACCESS TO ALL AUDIO
- FULL EQUIPMENT REDUNDANCY
- MUSIC LIBRARIAN SONG SCHEDULER
- TRAFFIC and MUSIC SYSTEM INTERFACES
- PROGRAM LENGTH RECORDING

OUR FULL-FEATURED, INCREDIBLY FLEXIBLE SYSTEM HANDLES ANY FORMAT AND RUNS MULTIPLE STATIONS FROM 1 CENTRAL NETWORK MACHINE. YOU CAN SHARE AUDIO BETWEEN STATIONS AND ACCESS ANY STATION FROM USER TERMINALS. THE SAVINGS REALIZED FROM GREATER EFFICIENCY AND THE COMBINING OF TASKS CAN DRAMATICALLY REDUCE YOUR COSTS!

Call Prophet Systems at 1-800-658-4403 for a full information packet, demo diskette, and users list. In Australia, New Zealand, and The Far East, contact Broadcast Solutions Pty Ltd. at (02) 439-6662.

Windows is a Registered Trademark of Microsoft Corporation. Novell is a Registered Trademark of Novell, Inc.

Circle (19) On Reader Service Card

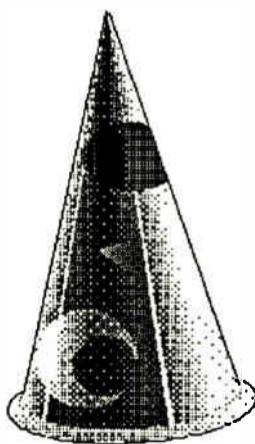

Finally, a Reason to Love Ma Bell



For years you've had to rely on satellites, and their sky-high prices. Now, Zephyr™ brings great sounding remotes back down to earth.

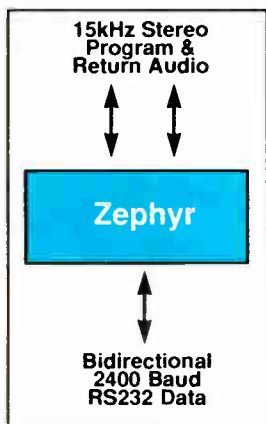

Integrated Services Digital Network (ISDN) dial-up phone lines are now available in most of the US and over a dozen other countries.

Using just one ISDN circuit, Zephyr transmits broadcast quality stereo for little more than the price of an ordinary voice call. And operation is as easy as sending a fax.

Zephyr uses Layer III to code and decode the audio for transmission. International listening tests, and the daily experiences



of hundreds of users, clearly demonstrate Layer III's superior performance when using ISDN.

Zephyr includes an ISDN terminal adapter, so no expensive external boxes are needed. For areas where only Switched 56 is available, Zephyr is totally compatible when using an external CSU/DSU.



You can even set up a remote with ISDN at one site and Switched 56 at the other! Our ISDN Telephone feature allows you to place

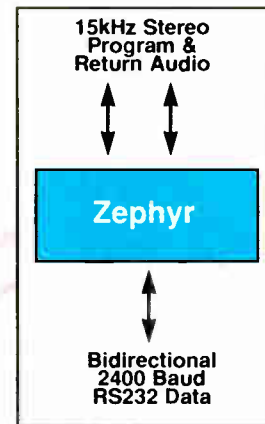

a standard voice-grade call to a Plain Old Telephone Service (POTS) phone.

only from



2101 Superior Avenue
Cleveland, Ohio 44114
216.241.7225
FAX: 216.241.4103

- Full duplex 15kHz stereo operation on one ISDN line or two Switched 56 lines using ISO/MPEG Layer III coding.
- Compatibility with older 7kHz codecs that use G.722.
- 2400 baud RS-232 bi-directional data for communications and control.
- Four end-to-end "contact closures" for summary alarm and control of recorders and other devices.
- Split channel mode allows individual mono signals to be transmitted to separate sites.
- The ISDN terminal adapter is built-in.
- V.35/X.21 port for connection to Switched 56, fractional T1, and other data paths.
- Simple operation with full metering, analog audio limiting, and straightforward controls.
- Each unit serves as both a transmitter or receiver.

The Best Way to Hear from There

Telos **Zephyr** DIGITAL NETWORK AUDIO TRANSMITTER

Why not get everything professional

Digital Audio Workstations have to offer?

Create your best part out of 10 recordings and use it in five different places... record 100 takes in the same place, on the same track... synchronize sound FX to a picture in less than a second... erase a word and bring it back a week later... and do all this on a machine that gives you instant access with incredible editing speeds, the sound quality you want, and the reliability you can count on, project after project.

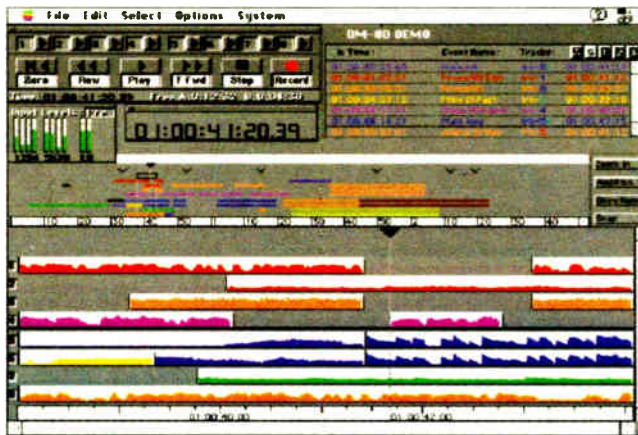

Optional DM-80-S Multitrack Manager control for the Macintosh®— easy to learn, fast to use.

the Word.

Problem is, many DAWs just can't give you all of these things.

Here's why:

Problem: Some systems use a single computer for graphic user interface *and* for audio information processing. This slows the whole system down, and makes you wait.

The Answer: A workstation that separates the hardware "engine" from the user interface computer. This way, audio information processing is not slowed down by the user interface, and the interface computer operates without the load of additional tasks. And you save time and money.

Problem: A system crash in the middle of a complicated project could cost you as much in time lost as some of the less professional DAWs are worth. You should expect reliability you can count on from your DAW, and get it.

The Answer: First, call around. Check the reputation of DAWs. We have DM-80s working every day all over the world in high volume production environments. Our customers will tell you they're reliable.

Problem: Some systems don't give you a user interface that's familiar and easy-to-use.

The Answer: Buy a DAW that lets you choose either a dedicated hardware remote that gives you familiar tape recorder controls, or computer software control that is simple to understand and easy to operate.

Problem: Some DAWs are the weakest link in the audio chain. The DAW you buy should deliver sonics as good or better than any piece of audio equipment you own.

The Answer: Choose a DAW from a company that knows professional audio, not just a company that knows computers. But most of all, ask audio professionals who own one.



We believe you'll find all these answers and more in the Roland DM-80 Digital Audio Workstation. Call us at (213) 685-5141, ext. 337, or FAX (213) 722-0911 for a brochure. Or better yet, schedule a demo. You're going to like what you hear.

"The thing is just impossible to screw up! The DM-80's non-destructive editing is the only way to go—revisions are extremely easy, and very quick."

— DAVID ESCH
DIRECTOR OF COMMERCIAL PRODUCTION
WPNT CHICAGO



"Edits fast, sounds great, and doesn't break. The DM-80's multilayering capabilities and simultaneous recording on all tracks gives us the flexibility to do whatever we want."

— JOEL VALENTINE
PRESIDENT
21ST CENTURY SOUND DESIGN, HOLLYWOOD
("NORTHERN EXPOSURE")

the Word on the street.

"The first DM-80 paid for itself in two months, so we bought a second one... I like the editing ease—no waiting. It's my 'word processor' for audio."

— MICHAEL STANTON
COMPOSER/ARRANGER
AUDIO PRODUCTIONS, INC., NASHVILLE



"The DM-80 is our secret weapon! It's a very enabling technology."

— MAZ & KILGORE
GRAMMY NOMINATED PRODUCERS
NEW YORK

"What goes in... comes out! And the sound is wonderful. Easy editing, plus easy sync to video lets me concentrate on the creative aspects of the production."

— RICHARD FREITAS
EMMY AWARD NOMINATED AUDIO PRODUCER
THE DOVETAIL GROUP, CONNECTICUT



"Operational speed and ease of editing make the DM-80 the greatest thing since sliced bread! We use it for all our production."

— VINCENT FUMO
SENIOR EDITOR
INDEPENDENCE BLUE CROSS, PHILADELPHIA

"The DM-80's power and speed allow me to complete a half-hour television documentary every week. As an investment, the DM-80 has proven to be a very smart choice."

— JIM HEFFERNAN
EMMY AWARD WINNING SOUND DESIGNER/PRODUCER
VIDEOSMITH, INC., PHILADELPHIA
("1ST FLIGHTS WITH NEIL ARMSTRONG")



The following is a partial preview of the products that companies will exhibit at The World Media Expo in Los Angeles. For a complete listing see the official exhibition guide.

COMPANY **BOOTH #**

360 Systems **1916**

Intro: HR550 Hard Disk Sampler, a professional digital audio recorder. OnScreen/II, a software program for DigiCart/II hard disk recorders. AES/EBU digital interface for DigiCart/II.

Also: DigiCart/II digital audio hard disk recorder, featuring an eight-hour hard disk drive, workstation editing functions, and playlisting functions. Series 2500 DigiCart/II. RC-200 series remote controls for DigiCart/II. PC Hot-Keys software for DigiCart/II. AM16/B audio routing switcher.

Contact: Doug Leighton
5321 Sterling Center Dr.
Westlake Village, CA 91361
818-991-0360

the illusion of water drops flowing uphill or suspended in mid-air.

Also: Audio and video accessories, such as cables, connectors, adaptors, components, and tapes. Audio/visual equipment, such as projectors, interfaces, walkie-talkies, and infrared wireless equipment.

Andrew Corp.

Intro: Three-inch diameter HRLine rigid transmission line. MT050 dehydrators.



AEO TLE-02

3950, 3951

Also: Microwave transmission equipment. Antennas include earth stations, MMDS, HMD, STL/TSL, UHF and VHF. Transmission lines include heliax coaxial cables and

HRLine rigid lines.

Anton-Bauer

958

Intro: Digital Trimpac battery, a 1.25 kg battery with the same amount of energy as two original equipment batteries. Lifesaver dual charger, a two-position Logic Series sequential fast charger for 12-30 V batteries. Lifesaver Q2 charger for travel or back-up applications. Ultralight Satellight, which becomes a self-contained lighting fixture when combined with any spare camera battery.

Also: Logic Series InterActive battery system, which calculates and displays remaining battery capacity to a built-in LCD.

continued on page 37 ▶

From San Francisco to Singapore From New Zealand to New York

CCS Audio Codecs Connect the World

A-Ware Software Inc. **1741**
On Display: MusicMaster, a music scheduling and inventory maintenance system.

Accu-Weather Inc. **3858, 3859, 3958**
Intro: UltraGraphix-32 Weather System, a 32-bit graphics access, display, paint, and animation system.

Also: A complete line of 32-bit graphics, including satellite imagery, NEXRAD Doppler, weather maps, and features. Accu-Weather Forecast, available to one television and one radio station in each market. A full range of weather graphics computer systems.

Acoustical Solutions Inc. **3001**
Intro: AlphaSorb wall panels and hanging baffles, absorbers available in standard and custom shapes and sizes. Modular recording booth, a prefabricated modular studio that blocks 47 decibels of sound. Audio Seal Sound Barrier, a dense, limp-mass vinyl barrier that blocks 27 decibels of sound.

Also: Alpha Pyramid and Alpha Wedge acoustic foam, Soundtex wall covering, AlphaFlex and AlphaEnviron hanging baffles, Audio Seal barrier/absorber blankets and Sonex products.

AEQ-America Inc. **2432**
Intro: ADC-3000, a multiformat digital audio codec with both ISO MPEG Layer II and CCITT G.722.

Also: TLE-02 telephone line extender, a portable mixer and digital telephone hybrid with frequency extender capability. TH-02 EX digital telephone hybrid. MP-10 portable mixer with five mic/line inputs and built-in telephone. AM-03 self-powered audio monitor. The MAR (Management of Audio Resources) System for recording and playback. On-air consoles, featuring the BC-500 and BC-2000 series.

Contact: Gerardo Vargas
2211 South 48th St., Suite H
Tempe, AZ 85282-1008
602-431-0334

Alden Electronics **4056-4058**
On Display: MajicTRAK, an interactive graphics presentation system for on-air weathercasters. A complete weather, sports, or traffic segment can be generated on a MajicTRAK, including transitions in and out of taped or live pieces. Individual or groups of symbols and text can be generated and overlaid onto existing maps.

Alesis **2151**
Intro: QuadraVerb 2 (Q2) MIDI-capable multi-effects processor.
Also: ADAT, Monitor One and other audio equipment.

Ametron Audio Video Inc. **2622**
Intro: Dimension 9, a product that creates



CDQ2000 Family

- 20 kHz Stereo Codec
- CD Quality Transmission
- ISO MUSICAM® Compression

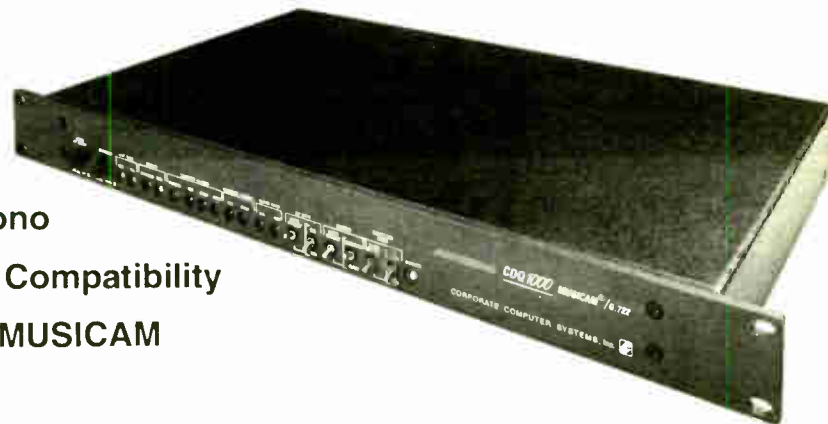

CDQ1000

- 10 kHz Mono
- Universal Compatibility
- G.722 or MUSICAM



MICRO FAMILY

- 7.5 kHz Audio Codec
- Broadcast Quality Transmission
- CCITT G.722 Compression

Discover Crystal Clear Digital Audio™ Discover CCS



CCS Audio Products
33 West Main Street
Holmdel, NJ 07733, USA
908-946-3800 FAX: 908-946-7167



CCS Europe GmbH
LudwigstraBe 45
D-85399 Hallbergmoos, Germany
49 811 5516 0 FAX: 49 811 5516 55

Products & Services Showcase

For more information on the products shown below, circle the appropriate Reader Service No. (s) on the enclosed Subscription/Reader Service card or contact the advertiser directly.



ETS

EAGLE TOWER COMMUNICATION SERVICE
Dunn & Bradstreet #808336994
419-424-0020

NATIONWIDE

- Lightening Deterrent Systems Sales & Install
- Slot Cover Replacement Deicer Repair
- Strobe Sales & Service**
- Custom Antenna Sales & Service FM-STL-2 way
- 8mm/Vi's Inspection & written reports**
- Core lube rustproofing & guywire replacement
- Custom Ice Shield & Mounting Hardware Sales & Installation
- Tower Painting
- Earth Station Sales & Services
- Guywire Tensioning

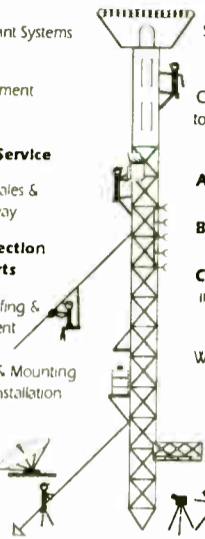

- SS or Guyed Tower Sales, Installation & Service
- Contract **ETS** for your annual tower & lighting maintenance
- Feedline Sales & Service
- Tower Plumb

Nationwide Rates

- A.** \$490 a day + parts, travel included
- B.** \$155 mo. + parts, tension & plumb included
- C.** \$45 mo. per lighting unit includes parts, travel, labor, tension & plumb

We offer a 15-40% reduction in list prices from 60 manufacturers

"OUR BUSINESS IS CLIMBING TO NEW HEIGHTS"

READER SERVICE NO. 97

NEW!

Composite Audio DA and Switcher!



APPLICATIONS

- Switching Between Composite STLs
- Main Alternate Processing Switching
- Feed Up to 3 Transmitters with Identical Audio
- SCA or SAP Generator Switching
- Non-Intrusive Composite Testing/Monitoring

FEATURES

- 2 Input Switcher
- 3 Isolated Outputs
- Individual Level Control for Each Output
- Front Panel and Remote Control with Full Status
- Power Fail Memory with Bypass Mode
- Inputs Selectable for Balanced or Unbalanced Operation

bdi Broadcast Devices, Inc.
5 Crestview Avenue
Peekskill, NY 10566
Tel. (914) 737-5032 FAX: (914) 736-6916

READER SERVICE NO. 89

SOUND YOUR BEST ON THE AIR!

CART MACHINE SERVICES:
CART MOTORS REBUILT to quiet flutter-free perfection-shafts resurfaced
Single \$120.00 Triple \$140.00

CART HEADS RELAPPED guaranteed to perform like new
Same day turnaround
Replacement heads and motors available

REEL TO REEL SERVICES:
HEADS RELAPPED and precise digital/optical
ASSEMBLY ALIGNMENTS performed for maximum response & head life
CAPSTAN & REEL MOTORS REBUILT for MCI, OTARI and more

For peak performance from your recording equipment, call The Audio Magnetic Professionals

AMP SERVICES
224 Datura Street, Suite 614, West Palm Beach, FL 33401
Call 1-800-826-0601 for "Same Day Service" in Florida (407) 659-4805
Authorized Parts Dealers for MCI • OTARI • TEAC/TASCAM

READER SERVICE NO. 50

EQUIPMENT FINANCING

MARTIN LEASING CO.

FIXED RATE LONG TERMS

- 1-Page Credit Application
- New or Used Equipment
- \$5,000-\$2,500,000
- 100% Financing—No Down Payment
- Conserves Bank Lines
- Under \$50,000—No Financials Required
- Other Equipment, Too!

UPGRADES
TRANSMITTERS
ANTENNAS
DIGITAL EQ.
AUTOMATION
STUDIO EQ.

QUICK RESPONSE 24-48 HOURS
BEN WEINGARTEN
1-800-253-2734 EXT. 22
TEL: (310) 274-7988 FAX: (310) 274-1905

THE BROADCAST EQUIPMENT SPECIALIST

READER SERVICE NO. 67

DIGITAL AUTOMATION SYSTEM

- The BEST Integrated Play List SCHEDULER (Music & Breaks) & ON-AIR Playback Combination Available Today
- MUSIC on Hard Disk and/or CD
- DOLBY AC2 Overlapping Hard Disk Audio

Pristine SYSTEMS INCORPORATED

- FEATURE RICH Digital Automation at an AFFORDABLE Price & Updated Quarterly
- Complete ON-LINE Redundancy
- Provide Your Own Computers/Players and SAVE \$\$\$ or Buy/Lease From Us

SEE US AT LA/NAB BOOTH 1830

WEST/INT'L **310/670-7500** EAST **803/370-2400**
FAX 310/670-0133 FAX 803/370-2314

READER SERVICE NO. 210

The CircuitWerkes TeleRadio Remote Controlled Listen Line



You can find out what's on the air in all of your markets without ever leaving your chair!

With the TeleRadio and a phone, you are ready to check up on your station and all of your competitors in real-time. You'll never have to get another station air-check plus you can punch around the dial as if you were right there. When the TeleRadio answers, its internal radio begins playing down the line to you. You control the tuner with the buttons on your phone. The TeleRadio is the next best thing to being there yourself.

The TeleRadio features include:
Ten random memory presets
Remote scanning, tuning, band change & memory set.
Remote controlled external audio jack lets TeleRadio double as a standard coupler for IIB, etc.
List price is just \$689.

CircuitWerkes
6212 SW 8th Place
Gainesville, Florida 32607
(904) 331-5999 / fax 331-6999

READER SERVICE NO. 125

Shively

A good FM antenna is crucial to quality broadcasting. An antenna that is merely adequate will compromise the performance of even the best studio equipment and transmitter.

Shively regularly includes standard features that other companies either provide only as options or simply do not offer.

At Shively, we design and build antennas of uncompromising technical quality and performance. And, we build them to last.

call or write for more information

Shively Labs

A Division of Howell Laboratories, Inc.
19 Harrison Road, Bridgton, ME 04009
207-647-3327 FAX 207-647-8273

READER SERVICE NO. 113



Excalibur Electronics CD-1 Interface Amp

The industry's favorite unidirectional interface amplifier is designed to match HF output standards (10kΩ unbalanced, -10dBV) to broadcast input standards (+4dBm, balanced). DC coupling, <0.006% THD & IMD, and >90dB S/N make the CD-1 appropriate for use with the highest quality CD players, as well as with monitor tuners, cassette and tape playback, DAT playback, and ENG equipment. Table-top mounting or, using the included angle brackets, may be attached to a rack panel, your cabinetry, or anywhere convenient. A dual version, the CD-2, is also available.

EXCALIBUR ELECTRONICS, INC., CHANTILLY, VIRGINIA
Please circle our bingo number for a data sheet and a dealer list

READER SERVICE NO. 82

Attention Advertisers!

Reach 22,000+ broadcast professionals! RADIO WORLD's Product Showcase provides a perfect medium for test marketing your products and services. It's an efficient, effective and affordable advertising option.

For more information, including rates and deadlines, fax your sales representative at

1-703-998-2966
or call
1-800-336-3045

► continued from page 35

Ultralight low-voltage light with a quick-change head module.

Aphex Systems 2526

Intro: Models 320A and 323A Compellor compressor/leveler. Model 722 Dominator II multiband peak limiter. Model 107 Tubessence two-channel vacuum tube mic preamp.

Also: Digidoc FM stereo generator. Model 105 four-channel logic-assisted gate. Model 106 Easyrider four-channel compressor. Model 622 expander/gate. Model 104 aural exciter type C2 with Big Bottom.

Contact: Brad Lunde
11068 Randall St.
Sun Valley, CA 91352
818-767-2929

Arbitron Co. 2100
Intro: Maximizer 3.0, a PC-based access to the respondent level data base of Arbitron's syndicated local market radio audience service.

Also: Syndicated radio audience measurement in 264 markets. LocalMotion, a local market, multimedia qualitative measurement.

Arrakis Systems Inc. 2532

Intro: 15 new features for DigiLink, including auto trim of audio files, tagged text for CD tracks and hard disk audio files, start and kill dates, and auto time announce. Gemini live digital audio workstations and mixing consoles. 1200 Series consoles. New features for the Trak*Star 8 digital multitrack editor. Desk*Star custom studio furniture.

Also: DigiLink digital audio workstation. Desk*Star standard studio furniture. Trak*Star 8.
Contact: Jon Young
2619 Midpoint Dr.
Fort Collins, CO 80525
303-224-2248

Associated Press 3106

Intro: APTV, an international video news service transmitting daily video feeds to the world's broadcasters. AP All News Radio, an all-news radio network providing live turnkey programming 24 hours a day.

Also: AP NewsCenter newsroom system. AP GraphicsBank, a dial-up data base of graphics. AP News Wires for state, regional, national, and international news, business, sports, and weather. AP NewsDesk, which sorts and edits AP wire copy and computes script read time.
Contact: Daryl Staehle
1825 King St., N.W.
Washington, DC 2000-1253
800-821-4747 or 202-736-1100

Audio Processing Technology 2908, 2910

Intro: DRT128 Digital Reporter Terminal for ISDN/Switched 56; ACE100PRO and digital audio expansion card for the PC.

Also: 302 digital audio transceiver (codec); ACE100PRO/ACE100D digital audio expansion cards for the PC; X-console editor software package.
Contact: Emma Wickens
Edge Water Rd.
Belfast, Northern Ireland Bt3 9JQ
+44-232-371110

Audio Technologies Inc. (ATI) 2723

Intro: NanoAmp Series MX100, a three-input mic/line mixer with companion XP100 four-input expander. BI100, BU400, and UB400 IHF to pro interface amplifiers.

Also: MicroAmp Series, NanoAmp Series, and Encore Series of microphone, line, turntable, power, distribution, and IHF interface amplifiers. Emph'a Sizer microphone audio processor. Studio metering systems. Single and multiple-output headphone amplifiers. Press Box microphone distribution amplifier. System 10,000 modular microphone, line, and distribution amplifiers. Vanguard Series six-, eight-, and 12-mixer dual stereo on-air consoles.
Contact: Samuel Wenzel
328 W. Maple Ave.
Horsham, PA 19044
800-959-0307 or 215-443-0330

Auditronics Inc. 1624, 1626

Intro: Destiny 2000, an on-air console designed specifically for live assist operation. Virtually every function of the console is under computer control via a single RS-232 port.

Also: AirMaster 90 radio on-console, 210 Series radio on-air console, 801/851 Series on-air and production console and 1900 Series IFB/Mix-Minus system.

Contact: Duncan Fuller or Steve Sage
3750 Old Getwell Rd.
Memphis, TN 38118
901-362-1350

AT&T 2122

On Display: Digital audio broadcasting systems (experimental prototype).

Audio Accessories Inc. 424

On Display: Audio jack panels and jacks. Pre-wired audio patch panels. Patch cords

and patch cord holders. Polysand. Video panels. RS-422 patching. Edac connectors and accessories. Nickel-plated patch cords.

Audio Precision Inc. 2009, 2011, 2013

Intro: View on-site test results of reduced-bit rate coder systems tested using the company's new Coder.DSP software for the System One audio test set.

Also: A full range of audio test sets. System One includes the System One, System One + DSP, and System One Dual Domain. Both DSP-equipped systems support the FastTest and FastTrig systems, which can test any audio channel in three seconds or less.

Contact: Tom Mintner
P.O. Box 2209
Beaverton, OR 97075
503-627-0832

Audioarts Engineering 2612

Intro: SDA-8400 distribution amplifier. Also: The A-50 and R-10 radio on-air consoles. MR-40 stereo production console.

Contact: Rick Strage
7305 Performance Dr.
Syracuse, NY 13212
315-452-5000

Australian Broadcasting Corp. 2900, 2902, 2904

Intro: D-Radio digital on-air radio system.

Also: D-Card digital audio multi-user editing, recording, and storage system.
Contact: Matthew Holliday
700 Harris St.
Ultimo NSW 2001
Australia
61-2-333-2209

continued on page 38 ►

For the world's strongest AM transmitters, look to Nautel

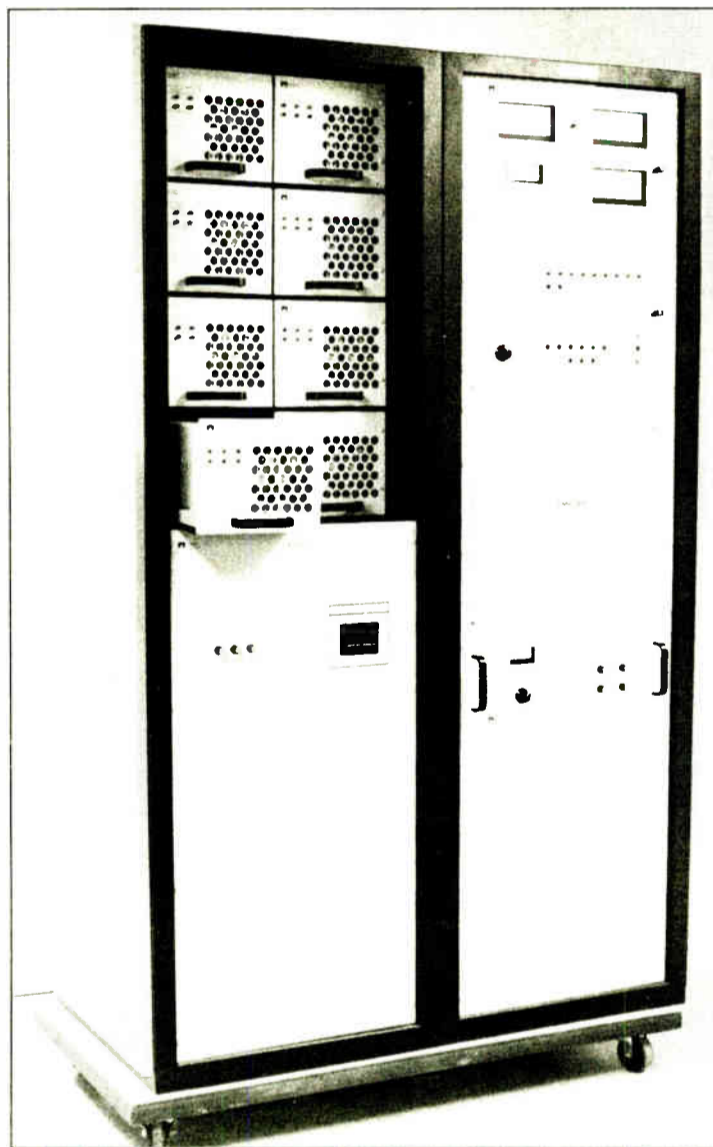

Totally solid state AMPFET ND 10 10kW AM

Nautel AM transmitters keep you on the air with an unmatched combination of value, performance and reliability

Low cost of ownership – with typical efficiency ratings up to 80 percent, a totally solid state Nautel transmitter pays for itself in tube replacement and utility

Superior audio transparency – Nautel AM transmitters utilize inherently linear digital Pulse Duration Modulation for the cleanest sound you can broadcast. Audio is ruler-flat throughout the range and distortion is typically less than 0.5%

Field-proven reliability – Nautel transmitters give you multiple protection systems for both power line and lighting transients, VSWR protection, soft failure design, reserve cooling and **safe on-air servicing**

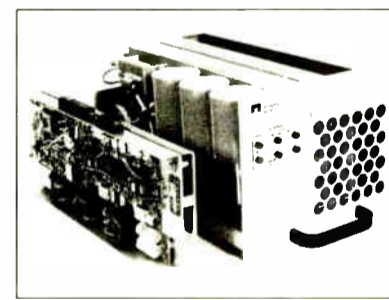

Removable AM Power Module

Make a strong transmitter choice. Call us today for all the facts on our totally solid state AM and FM transmitters.



Nautel Maine Inc.

201 Target Industrial Circle
Bangor, Maine 04401 USA

Phone: (902) 823-2233

Nautel

(Nautel Electronic Laboratories Limited)
R.R. #1, Tantallon, Halifax County,
Nova Scotia, Canada B0J 3J0

Fax: (902) 823-3183

► continued from page 37

Autogram Corp. 1843

On Display: PM 1032 audio console with 10 slide pots and 32 stereo inputs. MM-8A, a small, eight-slide pot audio console.

Contact: Ernest T. Ankele, Jr.
1500 Capital Ave.
Plano, TX 75074
214-424-8585

b

Basys Automation Systems 3840

Intro: MaestroWorks multimedia newsroom, featuring digital video playback and a digital video library. NetStation for Windows PC workstation with an intuitive graphical user interface and imbedded archive interface.

Also: NEWS newsroom automation system, including machine control, archiving, closed captioning, and election reporting. D-Cart digital audio record, edit, and playback system.

Belar Electronics Lab Inc. 2915

Intro: FMMA-1 FM digital stereo monitor/analyzer. SAP/PRO monitor for TV. RDS/RBDS monitor.

Also: FMMA-1 FM Wizard modulation monitor/analyzer. RFA-4 FM RF amplifier. AMMA-1, the AM Wizard.

Contact: David Hirsch
119 Lancaster Ave., P.O. Box 76
Devon, PA 19333
610-687-5550

Belden Wire & Cable Co. 850, 950

Intro: Single- and multipair 110 ohm digital audio cables. Low-loss serial digital video cables. SVHS video cables and Mini Star Quad mic cables.

Also: Precision video cable, video triax, transmission coax, fiber optics, 75 ohm conformable coax, Star Quad mic cables, and

line level audio cables, including single- and double-pair and multi-pair snakes.

Benchmark Media Systems Inc. 2714

Intro: Audioworld interface, which combines a two-way recorder interface with switch-selectable operation as a line amplifier or mono mix amplifier. Jr. Audio Director Plus, a stereo mode controller with four switch-selectable inputs per channel. DA-102DM two-channel audio distribution amplifier.

Also: System 1000 audio distribution system with more than 14 different cards and four power supplies. Microframe series of modular frame housing. Complete line of mode controllers, mic preamplifiers, meter systems, and interface amplifiers.

Contact: R. Rory Rall
5925 Court Street Rd.
Syracuse, NY 13206-1707
315-437-6300

Bext Inc. 2420

Intro: Lex 25, a programmable FM exciter/transmitter, from one to 20 W. The SF Series of solid state mosfet FM amplifiers, from 100 to 1,000 W.

Also: Selections from the company's line of FM exciters, transmitters, amplifiers, and STLs, and VHF and UHF transmitters from 25 W to 20 kW.

Contact: Dennis Pieri
1045 10th Ave.
San Diego, CA 92101
619-239-8420

BIA Publications/BIA Consulting 1701

Intro: TBA

Also: From BIA Publications, investment reference guides, directories, newsletters, and data base products on radio, television, and related industries. Publications include BIA's Radio Yearbook and Investing in Radio Yearbook. Newsletters include the BIA Forum and the BIA Monitor. BIA Consulting provides business evaluations, asset

appraisals, market research and business planning, and litigation support.

Bloomberg Financial 2220

Intro: Bloomberg Direct TV and Bloomberg News Radio.

Bradley Broadcast Sales 2922

Intro: Quick-Link RPU system from QEI, a digital stereo microwave system that uses spread spectrum technology and does not require a license. The Zephyr digital transceiver from Telos, providing 15 kHz of stereo audio on a single ISDN phone line.

Contact: Paul J. McLane
8101 Cessna Ave.
Gaithersburg, MD 20879
800-732-7665

British Information Services 2529

On Display: British Satellite News (BSN), an international television news pictures service delivered via satellite. UK Today, a half-hour television news magazine about life and events in Britain, produced each month in English and Spanish. Inside Britain, 26 half-hour programs providing a look at life in the U.K. TV facilities unit, which provides assistance to television stations covering stories on location in the U.K. Newsbreaks from Britain, a daily news feature audio actuality service filed by digital line from London.

Broadcast Design International 4128

Intro: Recent set design projects, including Fox NFL Sports, SBC Singapore, and WPLG in Miami.

Also: Newsroom and news set design and construction projects. Television facilities planning.

Broadcasters General Store 1819, 1821

On Display: Products from DNF Industries and Sine Systems.

Broadcast Electronics 2314

Intro: AM-500 500 W solid state AM transmitter. FM-2C 2 kW solid state FM transmitter.

Also: AudioVault digital audio storage system. Core digital automation system. Format Sentry automation system. AM-5 5kW solid state transmitter. FM-20B 20 kW FM transmitter. Operating studio.

Contact: Kim Winking
4100 North 24th St.
Quincy, IL 62301
217-224-9600

Broadcast Supply Worldwide (BSW) 1700

Intro: ProVox digital audio recorder.

Also: DigiLink.
Contact: Tim Schwieger
7012 27th St. West
Tacoma, WA 98466
800-426-8434

Burk Technology Inc. 2718

On Display: ARC-16 dial-up or full-time remote control systems for both small broadcasters to large multisite LMA operations.

Contact: Dan Rau
7 Lomar Dr.
Pepperell, MA 01463
508-433-8877

California Digital Audio Systems Inc. 2838

On Display: Digital audio network design and installation, satellite time, ISDN and Switched 56 services and equipment, digital hard disk solutions for networks.

Contact: Linda Donahue
5401 Tech Circle #3
Moorpark, CA 93021
805-523-2310

continued on next page ►

**50
DIGITAL
STEREO
TRACKS
UNDER
\$4,000!**

~And We'll Prove It!



Plays 50 simultaneous stereo tracks without bouncing!

- Add to your 386/486 computer
- Up to 2,900 segments available per project
- Non-destructive, precision digital edits in under a second
- -110 db noise floor & phase-linear filters
- Non-brittle, crystal clear sound quality
- Backs up to audio DAT
- Easy to install, easier to use!

"Excellent sonic quality... incredible freedom"
EQ Magazine, October 1993



Complete Work Stations Available!

Call For Your Free Catalog Today!

919/870-0344

FAX/870-7163

MICRO SOUND
Digital Audio Workstations

Micro Technology Unlimited • P.O. Box 21061 • Raleigh, NC USA 27619-1061

Circle (78) On Reader Service Card

World Radio History

► continued from previous page

CBSI/Custom Business Systems Inc. 2320, 2326
Intro: CustomReports and Design Financial Reports. The PowerPlus System and the Digital Universe digital audio system.
Also: Classic traffic and billing system. Elite traffic and billing system. InterAcct interactive accounting.

CCA 2620
On Display: FM broadcast transmitters; FM high performance excitors.
Contact: Steve McElroy
Box 426
Fairburn, GA 30213
404-964-3530

CCS Audio Products 2234
Intro: The Ultima and Prima digital audio codecs, part of a fully-integrated 20 kHz stereo codec system. PACE digital audio editing system.
Also: CDQ-1000 10 kHz mono codec using MUSICAM and G.722. CDQ-2001 20 kHz stereo codec using MUSICAM.
Contact: David Lin
670 N. Beers St.
Holmdel, NJ 07733
908-739-5600

Circuit Research Labs Inc. 2432
On Display: DAA-50, a hand-held passport to the digital audio domain, decoding AES/EBU, IEC958, S/PDIF, and EIAJCP-340 signals into stereo analog audio. Identifies channel status, format, sample frequency and shows interface errors. Amigo FM processor; Amigo AM processor, Audio signature digitally-controlled processing system, and the digital SC-100 RDS/RBDS generator.
Contact: Valerie Hummer
2522 W. Geneva Dr.
Tempe, AZ 85282
800-535-7648 or 602-438-0888

Clark Wire & Cable 852, 853
Intro: ADC True 75 ohm BNC for serial digital coax. RCC1V3AH remote composite cable. Complex II extended distance RG11-style coax.
Also: Audio and video cables and connectors. Custom cable assemblies, including DT12, RGB, remote composite cables, and audio snakes.
Carlyn Buchanan
151 S Pflingsten Rd., Unit B
Deerfield, IL 60015
800-222-5348

Columbine Systems Inc. 1808
Intro: Master Control Automation, which fully automates the airing of all scheduled events, including spots, programs, local production, and public service announcements.
Also: Traffic systems for a variety of technology platforms. Columbine Traffic automates the creation of the log and commercial insertion and prepares advertisers' billing statements. Sales analysis. Accounting/finance services, such as reporting and tracking of costs associated with certain programs or promotions.

Communications Graphics Inc. 2720, 2722
On Display: Screen-printed decals and bumper stickers, media folders, and credit cards.

Computer Concepts Corp. 2500
Intro: Visual Traffic (VT), a Windows-based graphical system for advertiser/agency accounts, sales maintenance, commissions and goals, log maintenance, copy and script management, reports, and accounts receivable.
Also: Digital Commercial System (DCS) hard disk audio system for live, automated, or satellite formats; allows simultaneous recording while playing back two channels for cross-fades.
Contact: Della Northcutt
8375 Melrose Dr.
Lenexa, KS 66214
913-541-0900



Computer Concepts DCS

Comrex Corp. 2128
Intro: DX100 apt-X digital audio codec. DX200 ISO/MPEG Layer 2 digital audio codec.
Also: DXP/DXR G.722 digital audio codec. One-, two-, and three-line frequency extender systems. Talk console, telephone couplers, RF cue systems, and sports consoles.
Contact: Lynn Distler
65 Nonset Path
Action, MA 01720
508-263-1800

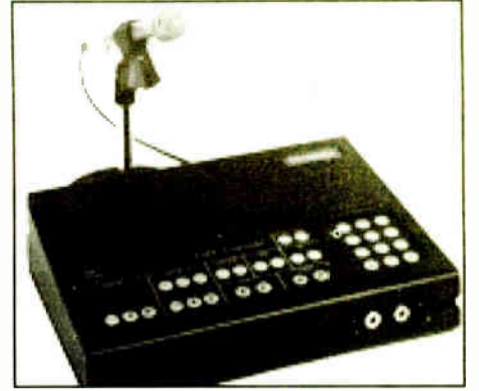

Comrex Talk Console

ComStream 2706
Intro: High-volume

receivers for delivering more than 100 channels of compressed video or audio directly to the user, at home or at work.
Also: Digital Audio Broadcast Network, continued on page 41 ►

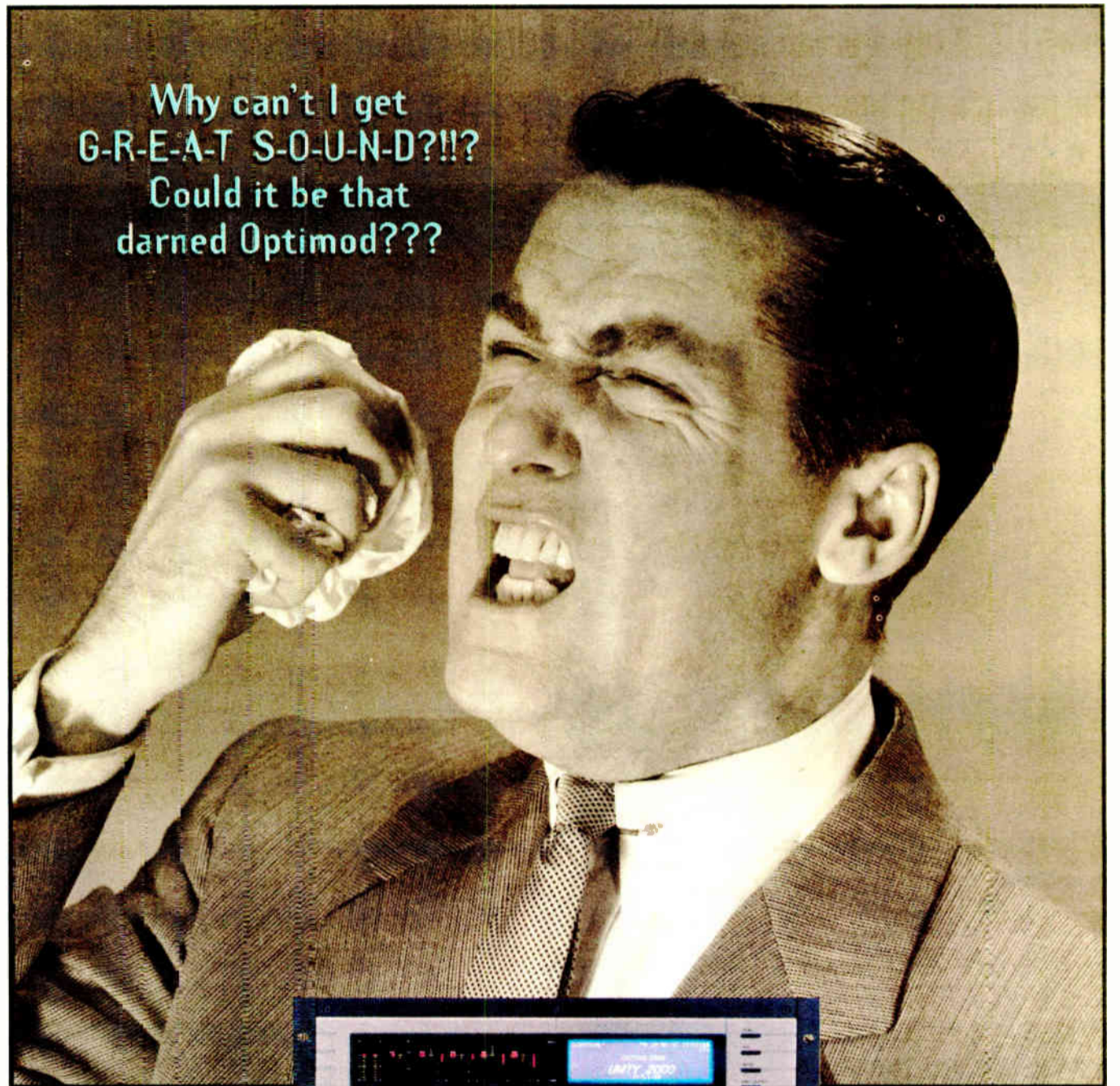

the unity 2000/ the world's best sounding FM processor.
Better sound, more listeners, bigger profits. That's what it's all about.



CUTTINGEDGE

2101 SUPERIOR AVENUE. CLEVELAND, OHIO 44114 • TEL: (216) 241-3343 • FAX: (216) 241-4103

Circle (172) On Reader Service Card

GET FAT

modulation sciences

STEREO
maxx



GET LOUD

modulation
sciences
inc.

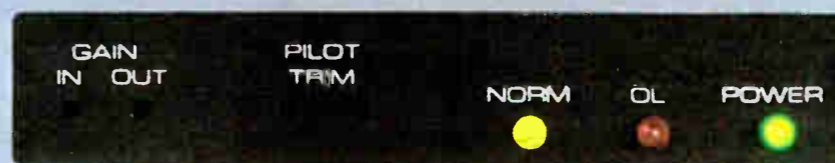

GET LEGAL

modulation sciences
modminder
digital



OVERMOD

PEAK MODULATION



DN

UP

ONE MINUTE COUNT



THRESHOLD

SETTING

GET FAT with StereoMaxx®

When everyone in town is processed to the max, what's left? The answer is StereoMaxx, a Spatial Image Enlarger that turns your listeners' Volkswagens into Cadillacs and their living rooms into concert halls. With StereoMaxx in your air chain, other stations will sound flat, dull and lifeless. Call us for a free demo tape!

GET LOUD with the CP-803

Add up to 6 dB more loudness with the CP-803 Composite Processor. The CP-803 works with your existing audio processing to give you the maximum modulation the law allows, with no ringing or overshoot. Installed at your transmitter site, the CP-803 will make your entire air chain sizzle.

GET LEGAL with FM ModMinder®

When you need accurate modulation measurement, you need ModMinder. With accuracy within 1 percent, FCC-approved ModMinder ignores brief audio peaks and often lets you increase modulation – legally. Internal calibration guaranteed for two years means you'll know where 100 percent is, right out of the box!

Used together or separately, MSI products keep you at the competitive edge. Learn how to excel in your market. Circle our Reader Service number, call your authorized MSI dealer, or contact the FAT, LOUD & LEGAL authority...

modulation sciences, inc.

12A World's Fair Drive • Somerset, NJ 08873 USA
Voice (908) 302-3090 • Fax (908) 302-0206
Toll Free in USA (800) 826-2603

► continued from page 39

featuring the ABR200 and ABR75 integrated digital audio receivers. Audio network for transmitting digital audio for various applications, including private radio network audio distribution, distribution to unattended FM transmitters, remote broadcasts, news and actualities, and multiprogram delivery service.

Continental Electronics Corp. 2427

Intro: TBA
Also: AM and FM transmitters of various power levels. Shortwave equipment, studio equipment, and other RF products.
Contact: Steve Claterbaugh
P.O. Box 27089
Dallas, TX 75227
214-381-7161

Crown Broadcast 2346

Intro: FM 30, an FM transmitter from three to 33 W. Higher power solid state FM transmitters. Low-power circular polarized antennas. Satellite network program control equipment.
Also: FM 100 100 W FM transmitter. FM 200 200 W FM transmitter.
Contact: Phillip Sandahl
1718 W. Mishawaka Rd.
Elkhart, IN 46515-1000
219-294-8233

Cutting Edge Technologies 1908

Intro: Unity Remote Software, which enables complete transmitter processing control from anywhere by modem. Unity AM processor and Unity 2000i FM processor. VIP-1 programmable voice processor.
Also: Dividend Composite Filter, which provides full spectral protection, including RBDS and other SCA signals.
Contact: Danielle Cline
2101 Superior Ave.
Cleveland, OH 44114
216-241-3343

Dalet 2814, 2816, 2818, 2820

Intro: An easy-to-use multitrack with unlimited virtual tracks (four stereo tracks per audio board; improvements on several other platforms.
Also: A wide range of digital audio applications for radio stations, from simple cart replacement for satellite to walk-away music automation off the hard drive. Users can switch from live assist to automation with a simple click of the button. The use of Windows makes Dalet applications user-friendly while allowing for true multitasking.

Dan Dugan Sound Design 2025

On Display: Model D automatic mixing controller. It assists sound operators in mixing multiple live mixes. It can eliminate errors in reinforcement, broadcasting, performance, and dialogue recording. The eight-channel VCA controller patches into console insert points.

Dataworld 1922, 1924

Intro: Extensive ethnic/demographic data reporting; detailed mapping; business profiles.
Also: Engineering services for the communications industry; analysis reporting; mapping.
Contact: John L. Neff, President
4827 Rugby Ave., Suite 200
Bethesda, Md 20824
800-368-5754

Dawn Satellite 2923

Intro: Coversat, a satellite antenna snow cover. Digital audio receivers. Digital-ready LNB amplifiers for use with the new digital receivers.
Also: Commercial satellite antennas.

Denon America 1709, 1711

Intro: TBA
Also: DN-990R and DN-980F MD cart machines; DN-951FA and DN-970FA CD cart players; DN-961FA, DN-650F, and DN-600 professional CD players; DN-770R and DN-730R cassette decks.
Contact: Michael Stelts
222 New Road
Parsippany, NJ 07054
201-882-7460

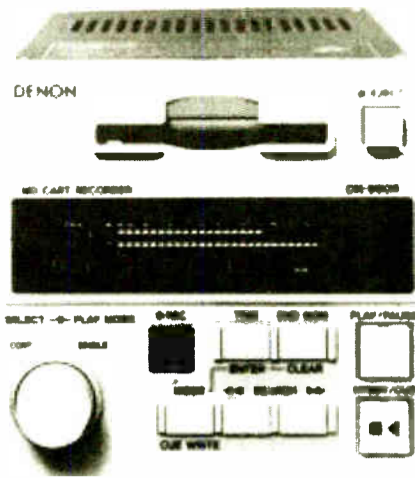

Denon DN-990R

Dielectric Communications 2216

Intro: Broadband rigid line "Digitline," HDTV ready transmission systems, RF systems for IOT transmitters, diplexers.
Also: TV and FM antennas, transmission line, waveguide, filters, and combiners.
Contact: Connie Eldridge
P.O. Box 949 / Tower Hill Rd.
Raymond, ME 04071
207-655-4555

Digital D.J. Inc. 2827, 2829, 2831

Intro: DDJ Receivers: include a large LCD screen that will provide a variety of visual information. When you hear a song on the radio, the DDJ display screen will tell you the name of the song, the artist's name, and more. When an ad is broadcast, you'll receive more information on the LCD screen such as addresses, phone numbers, and maps highlighting store location. In addition, DDJ transmission system. DDJ sends information on a radio station's FM subcarrier signal. The transmission technology, FMSS, allows for a data rate of 16 kbps on the 76 kHz frequency. A third new product is the DDJ Software, which will allow radio stations to design a DDJ program geared to the listeners. Stations will be able to send traffic information, weather and news reports, sports scores, concert and movie schedules, etc.

Dolby Laboratories 2008

On Display: Audio applications for the broadcasting, film, professional recording and home theater. Featured products include the DSTL digital studio-transmitter link, the Model 740 Spectral Processor, Dolby SR noise reduction equipment, DA20 Digital Film Sound Adaptor, and Dolby Stereo Digital. There will be no demonstration of Dolby Surround.
Contact: Erin Dare
100 Potrero St.
San Francisco, CA 94103
415-558-0200

Dorough Electronics 2123, 2125

Intro: AES/EBU audio level meter; video level meter model 40 N with alarm closure.
Also: Dorough Loudness Meters.

E-Z UP 1718, 1720

On Display: E-Z UP Instant Shelter Eclipse Model, developed from the original Series 9000 E-Z UP Instant Shelter and sets up in less than 60 seconds. It's used to keep cool on remote locations and includes highly-visible silk screened call letters. New features include the powder-coated white frame for a more elegant look, the high-strength steel oval trusses for increased stress resistance, a taller peak for a tighter fit, and larger, stronger outer legs.
The E-Z UP Instant Shelter Encore Model, developed from the original Series 9000 E-Z UP Instant Shelter. New features include a higher peak, additional sizes for added versatility and a lighter, stronger frame. Like other models, it sets up in less than 60 seconds; requires no ropes, tools, or assembly; and a full spectrum of fabric colors and accessories are available.

Enco 2727, 2729

On Display: DAD486X Digital Audio Delivery System.
Contact: Larry Lamoray
24403 Halsted Rd.
Farmington Hills, MI 48335
810-476-5711

Econco 2029

On Display: Medium- to high-power quality rebuilt power tubes and klystrons for radio and TV transmitters.
Contact: Debbie Baker
1318 Commerce Ave.
Woodland, CA 95776
916-662-7553

Energy-Onix Broadcast Equipment Co. 2733

Intro: One tube economically priced ECO FM transmitter from 4 to 10 kW; solid state FM to 3 kW; dual-channel short wave 10 kW transmitter.
Also: MK series of AM and FM broadcast transmitters, utilizing solid state, low power and vacuum tube power amplifiers, and the Energy-Onix line of portable solid state transmitters from 30 W to 1 kW.
Contact: Ernie Belanger
752 Warren St.
Hudson, NY 12534
518-828-1690

ERI-Electronic Research 1825

Intro: Site Keeper, a complete tower site monitor, alarm, and remote control unit for site considerations such as tower lights, antenna heaters, building and tower security, transmitter, environmental systems, and auxiliary generator.
Also: Directional FM antennas, lambda mounting systems, towers, filters, and combiners for commercial broadcasters. X series FM antenna.
Contact: David Davies
7777 Gardner Rd.
Chandler IN 47610
812-925-6000

Eventide Inc. 2927, 2929

Intro: H3000-B + Ultra-Harmonizer brand effects processor; H3000-B/LT Ultra-Harmonizer brand effects processor.
Also: H3500-B Ultra-Harmonizer; VR240 Broadcast Logger; DSP400 Ultra-Harmonizer; VP244 Audio Log Player; Eventide's Broadcast Obscenity Delays
Contact: Gil Griffith
One Alsan Way
Little Ferry, NJ 07643
201-641-1200

f

FM Systems 657

On display: VM771-Video Master, automatic gain control for video; ALM771, audio level master, automatic gain control for audio that's

Fidelipac Corp. 2560, 2562

Intro: 230 MB magneto/optical drive option with DCR1000 Series and additional software enabling over 100 separate cuts/diskette. New modules for MXE console: MicEQ module, Talkback/studio monitor module, telephone hybrid interface module.
Also: Dynamax DCR1000 series digital cart machine, CTR10 Series analog cart machine, broadcast audio console, Dynamax MX console.
Contact: Bob McNeil
P.O. Box 808
Moorestown, NJ 08057
609-235-3900

Focal Press 625

Intro: The Art of Data Recording, by John Watkinson; An Introduction to Digital Audio, by John Watkinson; Sound and Recording, An Introduction, 2 Ed, by Francis Rumsey and Tim McCormick.
Also: Our product line of over 150 books including professional, educational, and reference materials on broadcast and other electronic media. Topics cover technology, management, and production.

Fostex Corp. 2835

On Display: The Foundation 2000 LS, a random access digital audio recorder and editor designed for broadcast production. The unit is upgradable to a full Foundation 2000.
Contact: Steve Cunningham
15431 Blackburn Ave.
Norwalk, CA 90650
310-921-1112

g

Gentner 2222

Intro: Talk show telephone system TF612.
Also: VRC2000, digital hybrids, G3200, G2500, DHIII and SPH3a. Telephone interface products TC100, Auto Computer and Microtel.
Contact: Elaine Jones
1825 Research Way
Salt Lake, UT 84119
800-945-7730 or 801-975-7200

Gepco International Inc. 737, 739

Intro: VS10200, video snake cable; 10 different color conductors of the original VPM2000 cabled with an overall jacket. LVT61859S, 59/U triax with stranded center conductor.
Also: Gepco's complete line of audio and video cable products.
Contact: National Sales Manager
2225 W. Hubbard
Chicago, IL 60612
312-733-9555



Eventide DSP 400 Ultra-Harmonizer

hand-held, battery-operated audio and video modulation meters.

h

FirstCom Broadcast Services 1724, 1726

Intro: With MusiQuick, FirstCom's exclusive search and select software, you can instantaneously locate the perfect track for your promos and commercials.
Also: Help make any production project easier with the custom production library tailored specifically for your needs and budget. Also available: Techsonics, Direct Results Radio and Sound Ideas.

Holiday Industries Inc. 2721

Intro: Model HI-4000 RF/microwave hazard measurement system. Model HI-3520 microwave personal monitor.
Also: EMF measurement test equipment for a wide area of non-ionizing radiation; DC magnetic fields to 40 GHz.

continued on page 42 ►

▶ continued from page 41

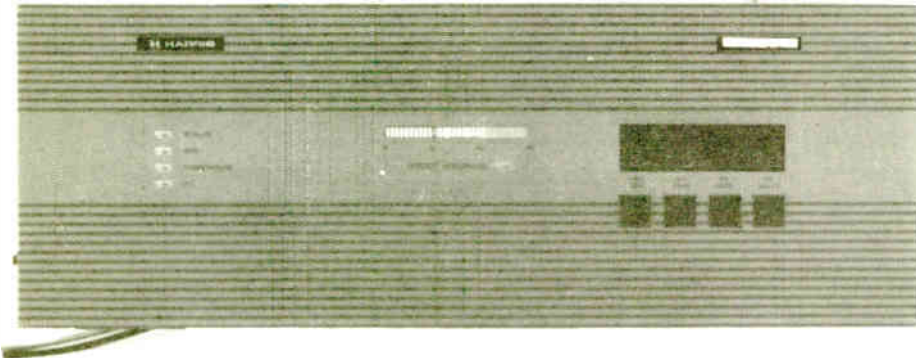

Harris Digit Digital Exciter

Harris Allied 2300

Intro: Harris DSE 1400 Digital Satellite Exciter/DSR 1400 Studio Grade Receiver, which as a digital SNG system uses the latest MPEG-2 video and audio compression standards to provide access to a greater range of transponder channels, reduced transponder costs, and more.

AES/EBU Input to Harris Digit Digital FM Exciter, which makes it possible for broadcasters to operate a 100 percent digital air chain from studio source equipment through the transmitter, eliminating all A/D and D/A distortions.

Digital I/O to DSE 7000, which makes the DSE 7000 available with a digital I/O. The audio system uses lightning-fast RAM for editing, massive hard disk storage for archiving and creating a sound library, and an easy-to-understand display.

Gentner TS612 DCT Multi-line telephone system, designed for fast-paced broadcast use. Features include connections for six phone lines, on-air/off-air talkability, expandable control surfaces, built-in digital superhybrids, and more.

Harris Allied plans to exhibit some new products that will not be pre-announced.

Also: Harris Platinum Series HT 10 HS VHF transmitter with Sentry PC Interface option; Harris Sigma Series HD 30C2; Harris Platinum Series PT 5FM FM transmitter; Harris DX 10 with AMS-G1 C-Quam stereo exciter; Harris Gates 5 MW transmitter; Harris Quest 1 FM transmitter; Harris HT 20FM FM transmitter; Enco DAD 486X digital audio delivery system; and DHK Audisk Audio Storage/Retrieval System.

Contact: Geoffrey Mendenhall
P.O. Box 4290 / 3200 Wisman Lane
Quincy, IL 62305-4290
217-222-8200

Inovonics Inc. 1941

Intro: RBDS encoder that requires no computer or programming knowledge; and an RBDS encoder that may be used with any FM mod monitor to meter injection level and display all RBDS data and messages.

Also: Full line of broadcast audio processors; stereo generators; the "Sentinel" all-mode monitor/receiver with program audio diagnostics; and an off-air FM modulation monitor.

Contact: Jim Wood, Pres.
1305 Fair Ave.
Santa Cruz, CA 95060
408-458-0552

International Datacasting Comm. (IDC) 2741, 2743

Intro: BPSK FlexRoute audio/data receiver for multichannel digital audio or mixed audio/data applications. Allows the use of low-cost DRO LNBS.

Also: Addressable QPSK and BPSK SCPC satellite transmission equipment for digital audio and/or data broadcast networks; the MPEG PRO series of digital audio receivers for radio network applications; DataNet addressable data broadcast receivers for multichannel, multimedia, or shared-hub applications; and a full complement of accessory products to address specific application requirements.

International Tapetronics Corp. 2116

On Display: DigiCenter digital automated management system; DPR digital program repeater; and an audio routing switcher.

ITS Corp. 636

Intro: ITS-830 1 kW solid state UHF transmitter, offering common amplification with broadband amplifiers, high redundancy, and many standard features.

j

Jampro Antennas Inc. 1816

On Display: JHD VHF panel antennas and JUHD UHF panel antennas; the JA/LS UHF slot antenna; the JIDC low-power digital combining system, available for FM, VHF, and UHF applications — handles up to 10 kW input power.

Jensen Transformers 1705

Intro: Jensen 68JT upgrade kit for the Magna-Tech 68B or 68C record amplifiers, featuring all-new electronics for ultra-low distortion, stable bias, and drift-free in/out timing.

Also: Jensen 69JT reproduce amplifiers for Magna-Tech film transports; full line of redesigned and improved JT Series audio transformers; and the Jensen Twin Servo 990 microphone preamp.

continued on page 44 ▶

i

IDB 2016

Intro: Telespot, a spot commercial delivery service offering digitized spots and instructions simultaneously delivered in the company's electronic package.

Also: Telesonic direct digital audio network offering 65 leading studios multiple Switched 56 or ISDN lines for master quality, including AES/EBU digital interface and time code/remote capabilities. Also Telesports, a state of the art digital network offering a full spectrum of remote transmission and distribution services that is deployed at popular venues throughout the United States and Canada.

ACCESS THE MAX!

RDS Global Messaging



Join the telecommunications revolution! Enter the lucrative paging and personal communications market with

Access 3000/RDS . . .

The most technologically advanced alphanumeric message transfer system (in any language) available today. Use your existing FM radio station for effortless paging, message and information transfer.

- ✓ TURN-KEY SYSTEM . . . AT AN AFFORDABLE PRICE
- ✓ NO MAJOR CAPITAL INVESTMENT . . . YOU ALREADY HAVE THE FM SUB CARRIER CAPABILITY
- ✓ JOIN THE NETWORK . . . BE PART OF A NATIONALLY FRANCHISED PAGING SYSTEM
- ✓ GREATER COVERAGE AREA . . . PERFORMANCE YOUR COMPETITION CANNOT MATCH
- ✓ READY MARKET . . . WITH VIRTUALLY UNLIMITED GROWTH POTENTIAL
- ✓ PROFIT POTENTIAL . . . WITH RECURRING REVENUE



MFG BY **SPARTON ELECTRONICS**

Access USA Communication Corp.
6620 Riverside Dr., Metairie, LA 70003 • (504) 889-9800 • FAX (504) 887-0950
Sparton Electronics
P.O. Box 788, DeLeon Springs, FL 32130 • (904) 985-4631 • FAX (904) 985-9855

SUBSCRIPTION/READER SERVICE FORM



FREE Subscription/Renewal Card

I would like to receive or continue receiving Radio World FREE each month. Yes No

Signature _____ Date _____

Please print and include all information:

Name _____ Title _____

Company/Station _____

Address _____

City _____ State _____ ZIP _____

Business Telephone () _____

Please circle only one entry for each category:

I. Type of Firm

- | | |
|------------------------------|---------------------------------|
| D. Combination AM/FM station | F. Recording Studio |
| A. Commercial AM station | K. Radio Station Services |
| B. Commercial FM station | G. TV station/teleprod facility |
| C. Educational FM station | H. Consultant/ind engineer |
| E. Network/group owner | I. Mfg, distributor or dealer |
| | J. Other _____ |

II. Job Function

- | | |
|---------------------------|--------------------------|
| A. Ownership | G. Sales manager |
| B. General management | E. News operations |
| C. Engineering | F. Other (specify) _____ |
| D. Programming/production | |

Reader Service

September 21, 1994 Use until January 21, 1995
Please first fill out contact information at left. Then check each advertisement for corresponding number and circle below.

Purchasing Authority

1. Recommend 2. Specify 3. Approve

001 023 045 067 089 111 133 155 177 199
002 024 046 068 090 112 134 156 178 200
003 025 047 069 091 113 135 157 179 201
004 026 048 070 092 114 136 158 180 202
005 027 049 071 093 115 137 159 181 203
006 028 050 072 094 116 138 160 182 204
007 029 051 073 095 117 139 161 183 205
008 030 052 074 096 118 140 162 184 206
009 031 053 075 097 119 141 163 185 207
010 032 054 076 098 120 142 164 186 208
011 033 055 077 099 121 143 165 187 209
012 034 056 078 100 122 144 166 188 210
013 035 057 079 101 123 145 167 189 211
014 036 058 080 102 124 146 168 190 212
015 037 059 081 103 125 147 169 191 213
016 038 060 082 104 126 148 170 192 214
017 039 061 083 105 127 149 171 193 215
018 040 062 084 106 128 150 172 194 216
019 041 063 085 107 129 151 173 195 217
020 042 064 086 108 130 152 174 196 218
021 043 065 087 109 131 153 175 197 219
022 044 066 088 110 132 154 176 198 220

Copy & Mail to: Radio World, PO Box 1214, Falls Church, VA 22041, or FAX to: 703-998-2966

Products & Services Showcase

For more information on the products shown below, circle the appropriate Reader Service No.(s) on the enclosed Subscription/Reader Service card or contact the advertiser directly.



Wired STL™

Our **Wired STL** lets you locate your audio processor and stereo generator in the studio. It transmits composite audio baseband through 2500 feet of inexpensive twinax line, so you can reach your **STL** on the roof or your transmitter down the hall.

Get our full story—contact your authorized *Modulation Sciences Distributor*, or the *Composite Audio Authority*...

modulation sciences, inc.
12A World's Fair Drive • Somerset, NJ 08873 USA
Voice (908) 302-3090 • Fax (908) 302-0206
Toll Free in USA (800) 826-2603

READER SERVICE NO. 7

TEXAS INTERNATIONAL MAGNETICS
Your Total Recording Media Source

1611 Herring Avenue • Waco, TX 76708
(800) 285-2856
FAX: (817) 756-0082
Professional Tape Delivered To Your Door

AMPEX 456 Grandmaster®
As low as... 1" \$ 52.68 per reel
As low as 1/4" \$ 6.49 per reel

AMPEX 499 Grandmaster®
As low as... 1" \$ 57.80 per reel
As low as 1/4" \$ 7.50 per reel

TDK S-VHS CM-30 (ADAT TAPE)
As low as... \$6.91 each

AMPEX 489 (ADAT TAPE)
As low as... \$7.65 each

TDK DAT (DIGITAL AUDIO TAPE)
As low as... R-16 \$4.49 each

AMPEX DAT (DIGITAL AUDIO TAPE)
As low as... R-15 \$4.23 each

BASF Chrome Plus CASSETTES
As low as... C-10 24¢ each

T.I.M. Also Offers Your Studio/Cientele:

- Audio • Video Duplication
- Real Time/High Speed Duplication
- Full Color Casetlines
- Graphic Design & Printing
- CD Replication
- Recordable CD Blanks
- CD "one-off" Recordings
- 3M 996 Mastering Tape
- BASF 911 Mastering Tape
- Computer Diskettes

Call For Additional Items.
"Since 1968"

READER SERVICE NO. 164



- CUSTOM ANTENNA PHASING SYSTEMS
- ANTENNA CONTROL SYSTEMS
- AM/MF ANTENNA TUNING UNITS
- DIPLEXERS & MULTIPLEXERS
- TRANSMITTER COMBINERS
- DUMMYLOADS (WITH MATCHING NETWORK)
- ASSOCIATED RF COMPONENTS
- CALL OR FAX FOR MORE INFORMATION

PHASETEK INC.

550 CALIFORNIA RD. UNIT 11
QUAKERTOWN, PA 18951
PHONE: 215-536-6648
FAX: 215-536-7180

READER SERVICE NO. 107

Crown's Winning FM Transmitters

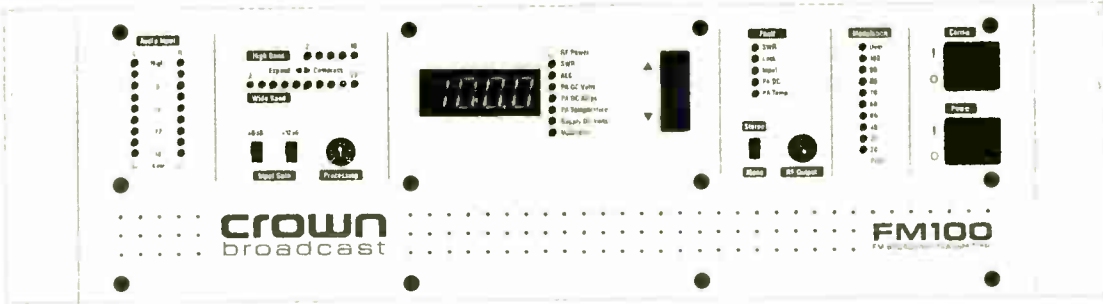

Crown's Complete Solutions For:

- Stand alone transmitter package
- Community and campus radio
- FM translator service
- Back up transmitters
- FM exciters

RadioWorld Cool Stuff Award
HAB 1994

CROWN broadcast
A Division of Crown International, Inc.
219-294-8000 Fax: 219-294-8329
Broadcast Sales: 219-294-8050

READER SERVICE NO. 106

ProGold™

Maximum Performance & Protection for Connectors

The Ultimate Contact Enhancer & Protector!

- Improves Conductivity
- Maintains Optimum Signal Quality
- Reduces RFI and Intermittent Signals
- Reduces Wear & Abrasion

Even the finest equipment cannot guarantee noise free operation. One "dirty" connection anywhere in the signal path can cause unwanted noise, distortion & signal loss.

ProGold conditioning treatment improves and maintains the performance of all electronic equipment and parts.

From the company that brought you Cramolin

CAIG Products ... used by those who demand the best!

CAIG
1424 West Bernardo Drive
San Diego, CA 92111
Phone: (619) 451-1799
FAX: (619) 451-1799

READER SERVICE NO. 99

ELIMINATE PODIUM CLUTTER.

PB2X8 Pressbox/Microphone Distribution System

MICROAMP SERIES



Eliminate the usual press conference microphone clutter with just a single or a back-up pair of microphones.

- Feed each of eight transformer isolated channels from either input or both Mic/Line inputs mixed.
- Drive a high level XLR and a medium or low level TRS line simultaneously from each output.
- Use as a 2X8 DA, stereo 1X4 DA or two input mixer.
- Studio grade performance, field proven ruggedness.

- Rack or desk mount
- Two low noise Mic/Line inputs
- Phantom power, low cut filter
- Loop thru expansion inputs
- Calibrated test oscillator
- Switchable bargraph VU meter
- XLR, 1/4" and 3.5mm TRS jacks
- Headphone output

SEE US AT BOOTH # 2723

CALL OR WRITE FOR A FREE DETAILED BROCHURE.

AUDIO TECHNOLOGIES INCORPORATED
328 W. Maple Ave., Horsham, PA 19044, USA
(215) 443-0330 (800) 959-0307
FAX: (215) 443-0394

READER SERVICE NO. 116

AXS (Ax'-sess)... Jocks Love It!

AXS is an entirely new approach to digital audio controllers. It starts with superb audio using the premium quality apt-X™ system. **AXS** is easy to learn, easy to use, and powerful beyond words.

AXS is a modular design that begins as a simple cart replacement and grows to any combination of CD, hard disk, satellite or specialty programming with ease.

AXS has all the sophisticated feature options including device independent multi-channel background audio record and replay. Macro programming makes tough to run event sequences easy. Software drives a powerful programmable real time IOMAP.

Jocks love AXS: A fast 99 page, 28 button Jock F/X panel that can be time linked and remote wired is standard.

Use a software driven four-channel stereo audio switcher with on-screen control or the powerful eight-channel dual-buss routing switcher, or include both if you wish. **AXS** is controlled through a trackball, touchscreen, keyboard, buttonbox, telco or remote modem.

AXS Systems...

From \$6000.00 using your 486 computers and hard disks.

READER SERVICE NO. 211



AXS

The Management

800-334-7823 • 817-625-9761
FAX 817-624-9741
P.O. Box 1-36457 Fort Worth, TX 76136
1700+ Stations • Our 14th Year

▶ continued from page 42

k**Killer Tracks 2834, 2836**

Intro: Tune-Builders by AirWorks, a self-editing software package now available with Killer Tracks and the B146 scoring library.

Also: Diverse, contemporary production beds; More than 120 CDs available in three distinct packages.

Contact: Diane Craig Lantz, Acct. Exec.

6534 Sunset Blvd.
Hollywood, CA 90028
800-877-0078

l,m,n**LARCAN-TTC 1600, 1602**

On Display: FMS Series solid state FM transmitters; XLS Series Solid State UHF TV transmitters and translators.

LDL Communications 3952, 4053

Intro: Multichannel FM antennas and combiner systems; Solid state VHF TV transmitter.

Also: Broadcast towers for FM and television.

Leitch Inc. 1113

Intro: MGI-1302N LogoMotion generator/ inserter.

Also: STILL FILE family of NTSC/D-2, 4:2:2(4), and RGB still stores; Digital Glue family of serial digital video products; MixBox standalone products; distribution amplifiers; routing switchers; sync and test generators; and master clock systems.

Logitek 1932

Intro: Ultra-VU expanded range LED audio meter; Crossfire II 12-channel ESAM-controlled audio mixer; and the Mini RateGate low-cost digital audio sample rate converter.

Also: Bright-VU low-cost LED meters; Super-VU LED audio meters with peak and average display; TR2 12-channel rackmount console; and the Mariner on-air audio console.

Contact: Tag Borland
3320 Bering Dr.
Houston, TX 77057
800-231-5870

The Management 1928, 1930

Intro: DMX-4B stereo audio switcher on an IBM PC card, which includes eight logic inputs and outputs, balanced stereo and summed mono audio out.

Also: AXS digital automation with multi-mode control.

Contact: Adrian Charlton, Gen Mgr.
P.O. Box 135457
Ft. Worth, TX 76136
817-625-9761

Marti Electronics 2426, 2428

Intro: Model STL-15C composite STL system, which is now available on international frequencies.

Also: STL-10 mono/stereo STL system; RPT-2 battery powered portable RPU transmitter; RPT-15 15 watt RPU xmitter; RPT-30 30 watt RPU transmitter; and the AR-10 and CR-10 RPU receivers.

MediaTouch Systems 2800

Intro: Pick N'play digital audio cart replacement system; Cut N' Splice digital audio editor; and DDI dumb device interface mechanical controller interface.

Also: OpLOG full-size automation control; Omniplay specialized automation control; and the Media DISK digital audio playback system.

Miranda Technologies Inc. 4320

Intro: ISO-101 4:2:2 detail enhancer. QLD-101 4:2:2 line doubler. Espresso, an SCSI to 4:2:2 interface.

Also: Complete line of digital video interfaces and interconnection products: encoders, decoders, routing switchers, etc.

Contact: Yvon Ouellet
8055 Trans-Canada Hwy.
St. Laurent, Quebec H4S 1L3
514-333-1772

Moseley Assoc. 2040, 2042

Intro: Starlink 9000 all-digital modular system for simplex/duplex transmissions; the DSP 6000 Option for ISO/MPEG source code, built-in AES/EBU rate converter; and MRC 2 option programmable intelligent co-processor module interfaces for the Tektronix VM700A video analyzer, satellite controllers, and video/audio switchers.

Also: MRC 2 transmitter control system; MRC 1620 transmitter control system; RPL 4000 remote pickup link system; PCL 6000 studio transmitter link system; and the DSP 6000 digital audio codec for RF and T1 applications.

Modulation Sciences Inc. 3510, 3511

Intro: New family of RDS/RBDS products, including the Model RDS-1 Coder, the Model PRD-3000 precision RDS decoder/monitor/analyzer, and the RDS-X Series of RDS data receivers.

Also: For television: a BTSC stereo generator; stereo reference decoder; TV ModMinder TV modulation monitor; SAP generator; PRO generator; PROceiver PRO receiver; and composite distribution amplifier. For FM recording and production will be the FM ModMinder modulation monitor; StereoMaxx spatial image enlarger; CP-803 composite processor; Sidekick Series audio and data subcarrier generators and data receivers; wired STL; and a composite distribution amplifier.

Contact: Arthur Constantine
12A World's Fair Dr.
Somerset, NJ 08873
908-302-3090

Moody Broadcasting Network 2735

On Display: ACCUWatch automatic transmitter monitoring service for radio stations, with demonstration hardware consisting of Gentner VRC-2000 and Sephyrus satellite receiving electronics.

Contact: David P. Woodworth
820-N. LaSalle Blvd.
Chicago, IL 60610-3284
312-329-4433

Motorola (Analog IC Div.) 3023

On Display: The MC13122/MC13027 AMAX receiver chip-set; the MC13028A and MC13029 AM/FM stereo receivers; and the MC13035 and MC13037 AM stereo receivers/FM decoders.

Nautel TBA

On Display: Solid state AM and FM transmitters — the AMPFET Series FM to 10 kW and the AMPFET Series AM to 100 kW-plus.

Contact: Bruce MacKenzie, Bcst. Sales
201 Target Industrial Circle
Bangor, ME 04401
207-947-8200

NEC America 3953

Intro: MLink-5000 briefcase satellite terminal, a self-contained (battery included) lightweight personal satellite terminal that provides worldwide voice and FAX communications (data communications coming soon).

Nemal Electronics 715

Intro: A line of flexible composite cables that include audio, video, and power under a single jacket.

Also: Precision audio, video, and snake cables, patch cables, and custom panels.

Network Music Inc. 2621, 2623

Intro: Trakfinder CD-ROM catalog, a sophisticated search tool that can audition a 29-second sample of any theme in the Network Production Music Library with the click of a mouse. A Windows version is now available and a Mac version is coming soon. Also shown will be the Network Classical Library, a 15-CD collection offering more than 130 of the most famous classical themes by the greatest composers of all time. In addition to the full-length themes, broadcast-length edits are available for each theme.

Also: Network music libraries, sound effects libraries, and production elements libraries.

NVISION 3200

Intro: The NVISION Digital Audio Processing Suite, providing tools within four rack units, including an NV1055 four-channel sample rate converter; an NV1060 digital audio delay compensator; an NV1050 four-channel sample rate converter; two NV1308 8x8 routers; remote control panels; and power supplies.

Also: NV1000 digital audio terminal equipment; NV2000 digital audio transmission system; NV3000 switching routers; the NV4448 sample rate converter and format converter; the NV5000 family of universal sync generators; and the NV9000 line of remote control panels.

NPR Satellite Services 1940

On Display: Full-time space segment on Galaxy IV as well as occasional service on Galaxy and Satcom G5. Uplinking services and Comstream digital audio equipment. Accommodate both digital and analog audio with company's C-band, SCPC audio transmission.

Contact: Miriam Lenett
635 Massachusetts Ave., N.W.
Washington, DC 20001
202-414-2626

Neutrik U.S.A. 2141, 2143

Intro: Nanocom, the smallest 3-pin XLR connector in the world, which features unique chuck type strain relief, lockable latch release, machined gold-plated contacts, and rugged machine metal housings. The Minicon, a miniature connector that uses up to 12 contacts and features unique chuck type cable retention and push-pull locking.

Also: XLR audio connectors (including solderless), 1/4" phono/jack "combo" connectors, bantam and 1/4" jack panels, patch cords, miniature and sub-miniature connectors, jacks, plugs, speaker connectors, and a full line of XLR accessories.

Contact: Ellen A. Wagner, Mktg.
195 Lehigh Ave.
Lakewood, NJ 08701
908-901-9488

Nucomm Inc. 414

Intro: Miniature microwave transmitter for wireless camera operation in the 1.990-2.50 GHz range with full remote control via a serial data port.

Also: Microwave transmitters and receivers for the broadcast industry. Includes rack-mount portable radios along with antennas and other necessary equipment for turnkey requirements.

o,p**Odetics Broadcast 1200**

Intro: The CacheMachine, a digital disk based system that plays spots directly to air from disk while programming material and spots are archived on tape.

Also: TCS90 cart machine, shown in a variety of formats with the latest in Odetics Automation Software.

Omnitronix Inc. 3043

On display: The Omni-1000 1 kW AM broadcast transmitter.

Optimod 2806

Intro: The DSE7000 digital sound editor, now an product, includes new features and a lower price. Optimod-TV Digital 8282 Audio Processor, designed specifically for analog and digital television audio. PC remote software for 8200 Digital Optimod-FM.

Also: Full line of Optimod Series broadcast audio processors.

Contact: Amy Herndon
1525 Alvarado St.
San Leandro, CA 94577
510-351-3500

Orban 2806

Intro: The DSE 7000 Digital sound editor, which includes new features at a lower price. Optimod-TV digital 8282 audio processor, designed specifically for analog and digital television. PC remote software for 8200 Digital Optimod-FM.

Also: Full line of Optimod Series broadcast audio processors.

Contact: Amy Herndon
1525 Alvarado St.
San Leandro, CA 94577
510-351-3500

continued on next page ▶

DON'T WORRY, I'LL CALL YOU IF THERE'S A PROBLEM

With the Sprint-7000 series of programmable SCADA controllers, you can rest assured that all of your vital systems are being monitored 24 hours a day. The 16 analog or digital inputs can be configured to send alarms to your alphanumeric or digital pager with whatever message text you desired. 16 relay outputs are standard, providing remote control from your PC terminal. The Sprint is fully programmable allowing unlimited system configuration. Call SMC at 1-800-527-1079 for more information.



▶ continued from previous page

Omnia Group Inc. 3852
Intro: New workshops designed specifically for the broadcast industry to help improve sales and management performance and ability.
Also: The Omnia Profile, a 10 to 12 minute personality test designed to give GMs an accurate measure of the sales ability of candidates and existing staff.

Otari Corp. 2546
Intro: RADAR, eight-, 16- or 24-track random access digital audio recorder. CDC-600 360-disc capacity, dual-drive CD changer. STATUS digitally controlled analog recording and production console. B-10 audio mixing console for broadcast applications. MR-10 MiniDisc recorder/player.

Also: Concept I digitally controlled automated mixing console. DTR-90T time code DAT mastering and production recorder. MX-50IIN two-track tape recorder.

Contact: James Goodman
378 Vintage Park Dr.
Foster City, CA 94404-1134
415-341-5900

Pacific Radio Electronics 2830
Intro: Unicom LAN products. 10 base T hubs, cards, cables and adapters. 10 base T cable for networking. Digital audio cable. True 75-ohm BNC connectors.

Also: Patch bays, cable, racks and accessories. Tools, chemicals for patch bay and machine maintenance. Audio and video patch cords, adapters, plugs and jacks. Wide range of broadcast cable and supplies for production and post production work.

Panasonic Broadcast & Television Systems Co. 837
Intro: AJ-D580 D-5 VTRs. Multi-audio processor. A5-D740 digital component switcher.
Also: MII "W" Power Series VTRs. AT-H1905D digital monitor. AG-DP800 Supercam S-VHS camcorder. AJ-D350 P-3 VTR.

Pacific Recorders & Engineering 2638, 2640, 2642
Intro: ADX Basic, a desktop version of the ADX WorkStation expandable to ADX WorkStation and MixStation systems.

Also: STX stereo television audio mixer, BMX III on-air console. ABX on-air/production console. AMX operations console. RadioMixer on-air console. ProductionMixer on-air/production console. StereoMixer stereo broadcast rack-mountable console. NewsMixer news operations console. SDA-8A stereo distribution amplifier. EXP-11 audio processing system. Broadcast Delay Controller. TX-990 stereo phonograph preamp. Five, 10 and 20 input line switchers. Program Selector Switcher. Molex patch bays and wiring systems. Full line of custom and modular broadcast furniture.

Contact: Mike Dosch
2070 Las Palmas Dr.
Carlsbad, CA 92009
619-438-3911

Pioneer New Media Technologies Inc. 728
Intro: Digital laserdisc and video server related products.

Also: VDR-V1000A rewritable videodisc recorder, a dual-head broadcast-quality component recording system. RM-V2000A Projection CUBE's video wall system. CAC-V3200 300-disc capacity CD autochanger with dual players.

Potomac Instruments Inc. 1714
Intro: AA-51A automatic audio analyzer, featuring balanced inputs, auto-null THD, frequency counter, IMB, stereo phase and ratio.

Also: Field meters, antenna monitors and remote controls.
Contact: David Harry
932 Philadelphia Ave.
Silver Spring, MD 20910
301-589-2662

Prime Sports Radio 2700
On Display: Information about 24-hour sports information radio network.
Contact: Gary Wendt
125 E. Carpenter Freeway
Irving, TX 75062
214-401-0972

Pristine Systems Inc. 1828, 1830
Intro: Drop Box, which allows instantaneous play of up to 26 hard disk audio files during on-air playback of playlist.

Also: Pristine Music Management and Commercial Control System, a digital automation system offering an integrated playlist scheduler and on-air playback combination.
Contact: William B. (Beau) Sanders
5855 Uplander Way, Suite E
Culver City, CA 90230
310-670-7500

Pinnacle Systems 4200, 4202
On Display: The Alladon Media Printer avail-

able in PAL format. Version 2.0 of the Prizm Video Workstation. Flash Grafix Composer. Flash Family of PC-based graphics creation and storage systems, including FlashFile Still Store, Flashbrowse and Flashnet Plus.

Promusic Inc. 1707
On display: More than 1,200 CDs of diverse music styles for corporate, audio-visual, radio, television and motion picture productions, including: Match Production Music Library; Digifects, Point 12 and Sound Ideas sound effects libraries; The Big Whoosh!! production elements disc.

Prophet Systems Inc. 1925, 1927, 1929
On display: Wizard for Windows digital broadcast system for live assist, satellite, hard drive automation and CD automation.
Contact: Yvonne Groteluschen
Box 509
Ogallala, NE 69153
308-284-3007

continued on page 47 ▶

AA-51A AUDIO ANALYZER NEW \$2595; UPGRADE \$1545

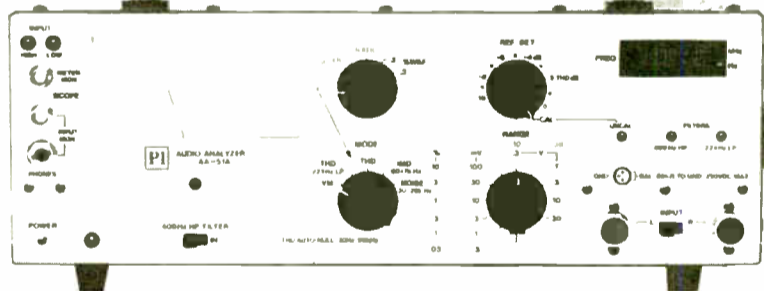

MEASURES:

- ✓ HARMONIC DISTORTION
- ✓ VOLTS
- ✓ dB; dBm (600 ohms)
- ✓ FREQUENCY
- ✓ WOW & FLUTTER
- ✓ STEREO PHASING
- ✓ SIGNAL + NOISE NOISE
- ✓ INTERMODULATION DISTORTION
- ✓ DIFFERENTIAL GAIN OF STEREO CHANNELS

FEATURES:

- ✓ AUTO-NULL THD+N
- ✓ SHIELDED & BALANCED STEREO INPUTS
- ✓ COMPATIBLE WITH NAB TEST DISKS
- ✓ FREQUENCY READOUT
- ✓ SWITCHABLE HIGH-PASS AND LOW-PASS FILTERS
- ✓ VERNIER SET-LEVEL CONTROL
- ✓ HEADPHONE INPUT MONITOR PORT

PLEASE CONTACT US FOR COMPLETE DETAILS



Potomac Instruments, inc.
932 Philadelphia Ave., Silver Spring, MD 20910
Phone 1-301-589-2662 • Fax 1-301-589-2665

Circle (92) On Reader Service Card

Quantum FM

Solid State

Solid Reliability

from



- Proven reliability
- Maintenance-free FET technology
- Self-contained modules with own power supply regulator
- Compact size reduces shipping costs, allows affordable air shipment
- Power levels between 300 Watts and 6 kW
- Modular design offers buy-only-what-you-need affordability and convenience

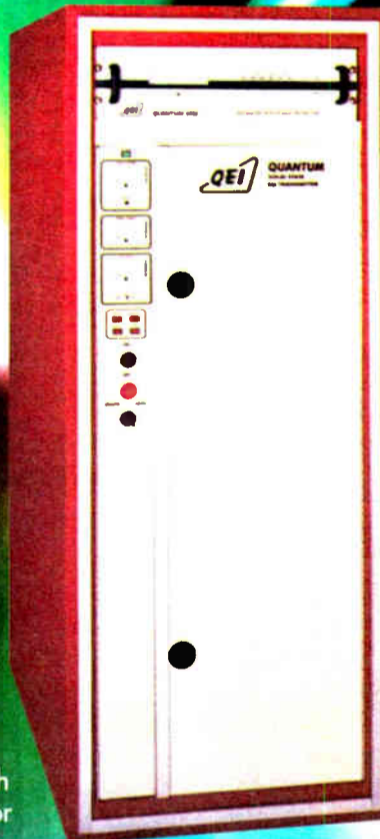

For the same price you pay for a tube transmitter, you can now have a superior solid state FM transmitter with high-power, advanced technology exciter and cableless combiner. The modular design of QEI's QUANTUM-Series FM transmitters offers the advantage of buying only the amount of power you need...and means that you can upgrade to higher power levels whenever you're ready.

QUANTUM from QEI - the people who have been designing and building solid state transmitters longer than anyone else in the industry.

You need to know more! Call Jeff Detweiler today toll free (800) 334-9154.

QEI Corporation
One Airport Drive • P.O. Box 805
Williamstown, NJ 08094

Tel (800) 334-9154
Fax (609) 629-1751

24-Hour Service Hotline
(609) 728-2020

Circle (141) On Reader Service Card

MOVE TO A HIGHER LEVEL OF RELIABILITY.

INTRODUCING BROADCAST ELECTRONICS NEW 2kW SOLID STATE FM TRANSMITTER.

Based on the ultra-reliable Broadcast Electronics FM-1C, our new FM-2C, 2kW Solid State Transmitter takes redundancy and reliability to a level unmatched by any other FM product. It's designed and built to save money and place you above your competition.

- Redundant RF amp and power supplies.
- Unmatched audio performance with the BE FM100C exciter.
- VSWR foldback allows operation into 3 to 1.
- Automatic AC Restart.
- Accepts 195 to 252 VAC, 50/60 Hz.
- BE builds it. BE backs it 24 hours a day, forever.

SAVE ON SOLID STATE

The entire family of BE Solid State FM Transmitters are the most cost effective on the market today. Before you decide you can't afford BE solid state, give us a call today.

CALL NOW. (217) 224-9600

OR YOUR LOCAL BROADCAST ELECTRONICS REPRESENTATIVE.

Get Digital Voice Remote Control FREE.

Buy any BE Solid State FM Transmitter before January 1, 1995 and get Digital Voice Remote Control FREE. A \$2450 value at no extra charge.



VMC-16 Digital Voice Remote Control System

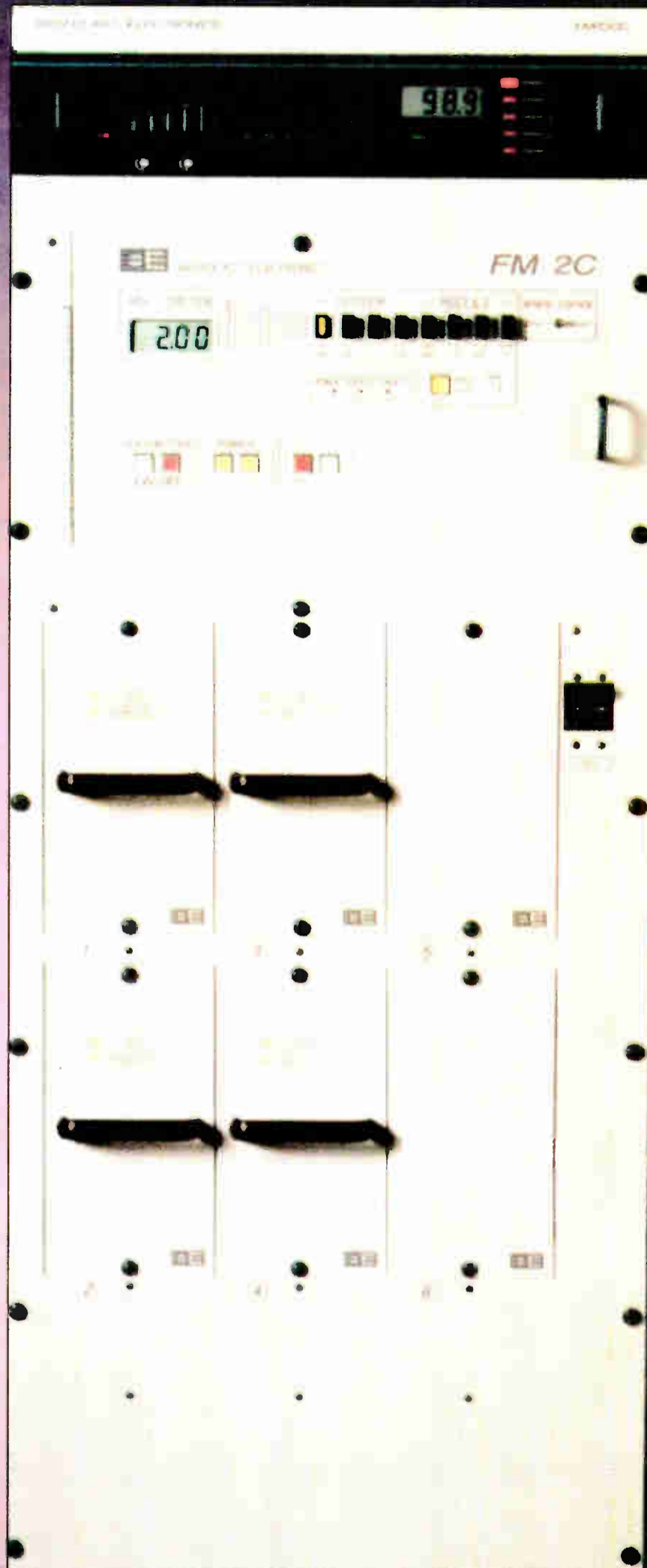

BE® BROADCAST ELECTRONICS, INC.

WORLD LEADER IN RADIO BROADCAST TECHNOLOGY

4100 N. 24th Street/P.O. Box 3606/Quincy, IL 62305 • Tel: (217) 224-9600/Fax: (217) 224-9607

THE POWER THAT SAVES

www.broadcastelectronics.com

Circle (124) On Reader Service Card

World Radio History

▶ continued from page 45

R,S

RCS—Radio Computing Services Inc. 1800
Intro: RCS NewsLink computerized newsroom with digital audio.
Also: Master Control all-digital, paperless, cartless radio studio. Selector music scheduling software. SongTrack music research software. RCS Traffic commercial scheduler.
Contact: Lee Facto, VP/GM
2 Overhill Road, Suite 100
Scarsdale, NY 10583
914-723-8567

Radio Design Labs 2636
Intro: ST-OSC2 A/B audio oscillators. ST-SX4 4x1 audio switch. RLC1 remote level controller. ST-RG1 digital DC ramp generator.
Also: ACM-2 AM noise monitor. AMX-84 8x4 stereo audio matrix. Full line of Stick-On and Rack-Up products.

Radio Express 2514
Intro: Exitos Express and the World Chart.
Also: Sound Designer production and scoring library.

Radio Systems 1706
Intro: DDS hard disc audio "cart" machine.
Also: RS-Series six-, 12-, 18- and 24-channel consoles. Super Clock line of analog and digital clocks and timers. Distribution amps and TI-101 telephone interface.
Contact: Daniel Braverman
P.O. Box 458 / 601 Heron Dr.
Bridgeport, NJ 08014
609-467-8000

RadioVision Inc. 2736
Intro: Cutting-edge 3-D animation and TV spot production for promotion of radio and TV stations.

Ramko Research 1735
Intro: ProMod ultra miniature audio/video/digital modules. ProMax modular audio system.
Also: xL Series broadcast/production consoles. RS1616 audio/data switcher. ICS-1 and ICS-1A intelligent control systems. System 2000 integrated audio system.

RE America Inc. 2738, 2740
On display: RE 660/661 MPEG Layer II audio codec for transmission of up to 20 kHz stereo over ISDN phone lines including AES/EBU I/O. RE 662/663 Layer II audio coder for multiplexing up to three ISDN lines for 384 Kbps contribution transport. RE532 RBDS encoder. RE 4500 component digital video codec for contribution quality 4:2:2 video transport over DS-3 networks.
Contact: P. Andrew Bosworth
31029 Center Ridge Rd.
Westlake, OH 44145
216-871-7617

Roland Corp. U.S. 2826, 2828
On display: DM-80 four- or eight-channel digital audio workstation for commercial music, post- and broadcast production. SN-550 digital noise eliminator, a single-ended real-time noise elimination system. SRC-2 dual sample rate converter converts any format completely within the digital realm, featuring digital mixing capabilities for crossfade and mix between two digital sources to any destination at any common sample rate.
Contact: Erika Lopez
7200 Dominion Cir.
Los Angeles, CA 90040-3696
213-685-5141, x 338

SADIE Inc. 3007, 3009
Intro: Latest version of digital audio editor software, free to all customers, including: alternative back up to match the faster Exabyte 8mm system, a hardware controller interface, improved time scrunch for editing speech, pitch shift, direct SCSI CD-R creation to red book standard and DDP CD mastering format on 8mm Exabyte tape.
Also: SADIe digital audio editor includes 18-, 20- and 24-bit editing, full PQ editing for CD mastering, 9-pin interface for external hardware machine control (with addition of RS-422 interface card), auto-conforming edit decision lists and implementation of background networking for multiple systems.
Contact: Jeff Boggs
1808 West End Ave., Suite 119
Nashville, TN 37203
615-327-1140

ScheduALL by VisuALL Inc. 3856
Intro: Personnel Manager with new timecard and payroll support features. Personnel Manager warns of overtime and other penalty situations, allowing you to select the best person for the job every time.

Scott Studios Corp. 2606
Intro: Scott System for news/talk/sports stations, including console control, interface with newsroom, wal of carts, level control and unlimited access to digital audio. New graphical waveform digital audio editor and Scott System for music stations with unlimited on-line music library on 9GB hard drives.
Also: Scott System for satellite programming and Scott CompuCart System for digital cart machine replacement.
Contact: Dave Gerety
13375 Stemmons Freeway, Suite 300
Dallas, TX 75234
800-330-3004

Shively Labs 2726, 2728
Intro: Model 6961 MMDS wireless cable repeater antenna, boasting extremely low weight and windload, a beam width of 80 - 120 degrees, and a standard input power rating of 250 watts.
Also: Companies complete line of FM broadcast antennas, in side-mount and panel designs, and related gear such as multistation combiners, rigid coaxial transmission line, filters, pressurization equipment, and detailed omni and directional pattern work.
Contact: Jonathan R. Clark
19 Harrison Road
Bridgton, ME 04009
207-647-3327

SMARTS Broadcast Systems 1829, 1831
Intro: The generation 2000 Digital Audio Network, a networked series of computer nodes, each capable of multiple operations. Each node capable of performing multiple simultaneous operations, including record and playback, overlap audio or schedule programming.
Also: Company's established SMART-CASTER, available in several models for different applications, including: SC-100 The Orbiter, designed for satellite or hub and spoke automation; SC-200 The Starlight designed for satellite automation, allowing simultaneous record/playback of audio; SC-300 The Galaxy designed for CD automation or satellite, can store and playback audio in stereo, overlap audio, stretch and shrink recorded spots to fit exact time requirements, and the SC-400 The Pulsar capable of storing an entire music library on the hard drive.
Contact: Dave Potratz
P.O. Box 284
Emmetsburg, IA 50536
800-747-6278

Solid State Logic 4257, 4259
Intro: Scenaria Omnimix, a digital surround sound audio/video system. Screensound VS with vision track.
Also: SL 8000 G Plus multiformat console. Scenaria digital audio/video system.

StandardNews Radio Network 1737, 1739
Intro: PC-based digital audio express, daX, designed to give you total control of network audio, data, news and information feeds.
Also: Radio network that provides audio 24-hours a day, a complete news service with specialized features. Zapnews, a 24-hour wire service available by fax or satellite.

Strata Marketing 962
Intro: AXIS, a system-wide integrated management service.
Also: Company offers television and radio quantitative and qualitative ratings, yield and contact management software services.

Superior Electric 2821, 2823
Intro: STABILINE SL Series uninterruptible power supplies; line interactive UPS systems available in VA ratings of 400 to 2,200 VA.
Also: STABILINE WHR Series automatic voltage regulators, STABILINE WHC series power conditioners, STABILINE UPSY series uninterruptible power supplies and STABILINE PQI series transient voltage suppressors/RFI filters.
Contact: Ted Gladis
383 Middle Street
Bristol CT 06010
203-585-4556

S.W.R. Inc. 3003, 3005
Intro: MMDS Antennas.
Also: Television and FM radio antennas and transmission line and waveguide.
Contact: Edward J. Edmiston
R.D. No. 3, Box 182
Ebensburg, PA 15931
800-762-7743

t,u,w

TapSCAN Inc. 2228
Intro: TapSCAN for Windows rating analysis system. Prospector business and sales research information. County Coverage Research System. SalesSCAN sales history management system.
Also: TapSCAN ratings analysis system. Retail Spending power. Multimedia. TargetONE. GridONE. Continuity Director traffic system. MusicSCAN music scheduling software. MonitorSCAN newspaper database.
Contact: Cindy Kimbrough
3000 Riverchase Galleria, 8th Floor
Birmingham, AL 35244
205-987-7456

Tektronix Inc. 1300
On display: Profile Professional Disk Recorder, disk-based platform for video and audio. Digital and analog test and measurement instruments, including AM700 audio measurement set for mixed digital/analog analysis and WVR500 waveform/vector rasterizer. Hand-held WMF90 waveform/vector/ audio/picture monitor and a wide array of palmtop devices for video and audio.

Telecast Fiber Systems Inc. 621,623
Intro: Adder fiber optic digital audio "snake," which transmits 64 channels on one optical fiber or on one coaxial or tri-axial cable.
Also: Sidewinder fiber optic ENG/EFP video/audio snake system. Viper fiber optic system.
Contact: Richard A. Cerny
102 Grove St.
Worcester, MA 01605
508-754-4858

Telex Communications Inc. 729, 731
Intro: FMR-450 UHF wireless microphone system. BP-1000 and 2000 beltpack headset station. KP-800 matrix keypad. Desk mount keypad. IFB-325 and IFB-1000 IFB beltpacks. IFB-4030 stereo IFB beltpack.
Also: Wired and wireless microphones. Wired and wireless intercoms. Headphones and headsets.

Telos Systems 908, 1910
Intro: Zephyr digital audio network transceiver, capable of transmitting bidirectional 15 kHz stereo audio over a single ISDN line. It is also appropriate for Switched 56 and other digital audio links.
Also: Telos' range of broadcast-to-telephone interfaces, including: Telos 100 Delta digital hybrid; the Link for connecting dial-up phone lines to production intercoms; the ONE plus ONE dual hybrid; and Call Screen Manager software for talkshow production. Complete talkshow systems including the ONE-x-Six.
Contact: Danielle Cline
2101 Superior Ave.
Cleveland, OH 44114
216-241-7225

TFT Inc. 1608, 1610
Intro: DSS93 Digital Subcarrier System for TV microwave and satellite applications. EIS 991 and 912 new technology Emergency Broadcast System to generate and detect new codes. EIS 930 multi-channel receiver.
Also: Model 850 BTSC modulation monitor/analyzer. Model 860 distortion analyzer. Model 855 SAP and pro monitor for complete operation observation and critical analysis of TV stereo, SAP and pro channels.

Thomson Components and Tubes Corp. 4441
Intro: TH760 10T 60 kW for HDTV/UHF transmission. TH680 diacode 80 kW for HDTV/UHF transmission.
Also: TH563 tetrode 30 kW for HDTV/UHF transmission. TH558 tetrode 500 kW for short-wave transmission.

TM Century Inc. 2600
Intro: Playback CD-ROM production library. Television campaigns.
Also: UDS II complete digital studio system for live or satellite-programmed stations. GoldDisc and HitDisc complete CD format libraries. Production libraries. Station IDs. Comedy network.

Toby Arnold & Assoc. TBA
Intro: Attitude II music library; Lifestyles full-service AC library; Fun Radio music library

with CHR, Hot AC, and urban sweepers.
Also: Attitude, Visions, Rock Attacks and Rocking Country music production libraries. Sweeper packages, including Generation X1, Generation X2, AC Plus, and Young Guns. Client jingles for radio and TV stations.

Valentino 2023
Intro: Production music and sound effects libraries on audio CD and CD-ROM.
Contact: F.T. Valentino
P.O. Box 534 / 500 Executive Blvd.
Elmsford, NY 10523
914 347-7878

Weatheradio 2147
Intro: Digital Weatherman II weather automation system, computer-based automation providing 24-hour walk-away weather featuring audio forecasts, bulletins, radar reports and current conditions.
Also: Weatheradio 24-hour, 365-days per year forecast services for radio.

Weather Services Corp. 1728
On display: Personalized and customized weather broadcasting services, exclusively to radio stations throughout the U.S., Canada and the Caribbean.

Wegener Communications Inc. 1628, 1630
Intro: DVR Series MPEG digital video product family including encoders, decoders and satellite integrated receiver decoders (IRD).
Also: Audio, data and video transmission for satellite-based networks.

Westwood One Entertainment 2254
Intro: Information about the addition of Richard Simmons' new show and Mike Walker's new talk show.
Also: Information about other Westwood One radio programming, including interview shows, talk shows, countdowns, concert programs and youth entertainment programs. Live broadcasts from Pat Buchanan, David Brenner, and Bruce Williams.
Contact: Gordon Peil
1755 S. Jefferson Davis Hwy.
Arlington, VA 22202
703-413-8550

Westwood One Radio Networks 2254
Intro: Westwood One '70s format, featuring classic music from the '70s.
Also: Eight 24-hour satellite-delivered formats, including CNN Headline News.
Contact: Kirk Stirland
1675 Broadway
New York, NY 10019
212-247-1600

Wheatstone Corp. 2612
Intro: A-6000 master air console with totally flexible architecture and comprehensive built-in logic and audio programming features.
Also: TV-600 master audio control console with integral event computer, Smart Select automated source switching and Bus-Minus IFB system. A-300 and A-500 radio on-air consoles. SP-4 and SP-6 stereo production consoles. Rackmount signal processing gear and modular studio furniture.
Contact: Ray Esparolini
7305 Performance Dr.
Syracuse, NY 13212
315-452-5000

Will-Burt 606
Intro: Electro-mechanical telescoping masts for RENG and ENG use.
Also: Pneumatic telescoping masts for RENG and ENG use.

Winsted Corp. 656
Intro: Multimedia furniture featuring a recessed monitor well for ergonomic viewing.
Also: Full line of broadcast rack, consoles, tape storage and more.

Wireworks Corp. 1935, 1937
Intro: TE-3+ cable tester for XLR, TRS and BNC cable assemblies. XLR I/O microphone splitters. Neutrik Speakon-terminated speaker cable assemblies. TEN-4 speaker cable tester for Speakon and TRS cable assemblies.
Also: Microphone multicable components group. Multipin disconnectable audio cable components.

Wohler Technologies Inc. 4207, 4209
Intro: SurroundSound monitor, a 2-RU high unit that decodes a Surround encoded audio program with continuous aural monitoring of left and right channels, level meters for all four channels and selectable speaker monitoring of either center or rear channel audio.

Wolf Coach Inc. 712
Intro: Power Truck, new generation satellite uplink/production truck with more space and features in a smaller truck.
Also: Benchmark Van for ENG use in a standard-sized package.

Digital Audio Performance!

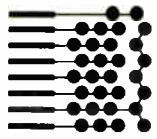

AUDIOARTS ENGINEERING A-50



- **Modular design**
- **Gold contact switches**
- **On-air tally opto relay standard**
- **Table-top mounted, no cut out required**
 - **Program, Audition, and Telephone buses**
 - **Built-in interface for external machine control**
 - **Almost any combination of mic and line modules**
 - **Available in 8, 12, and 18 input module configurations**

Call Northeast Broadcast, the experts in studio and RF systems integration. From new construction & rebuilds to digital audio products and ISDN digital audio transmission. Northeast Broadcast provides appropriate solutions for almost any application.

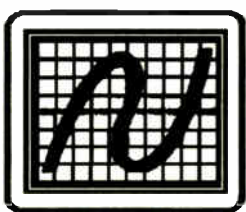

NORTHEAST BROADCAST

Broadcast System Integrators

(518) 793-2181

Main Office

The 1994 World Media Expo Session Schedule

Wednesday, October 12

—SBE—

Workshops designed to provide detailed information on maintenance and operation on key types of equipment and services. Workshops are half-day or full-day sessions and may include off-site "field trips."

Half-Day Sessions — 12:30 p.m. - 3:00 p.m.

Full-Day Sessions — 8:30 a.m. - 4:30 p.m.

—RTNDA—

3:00 p.m. - 5:00 p.m. — Radio and TV Critiques for Professionals:
- Take Your Best Shot: Radio News
- Take Your Best Shot: TV News

Radio and TV Critiques for Students

6:00 - 7:30 — RTNDA Edward R. Murrow Awards Reception

7:45 - 9:00 — RTNDA Edward R. Murrow Awards Presentation

9:00 — Post-Awards Reception

—NAB Radio Show—

8:30 a.m. - 12:30 p.m. — Radio Station Tour
- Broadcast Financing for the 1990s: The New Realities

1:15 - 1:45 p.m. — Sneak Preview for Newcomers and International Guests

2:00 - 9:30 p.m. — Alternative Revenue Streams: We Haven't Scratched the Surface Yet
- Youth Market Sales Workshop
- Mature Market Sales Workshop
- Hispanic Market Sales Workshop
- Air Personalities Plus

3:30 - 8:30 p.m. — Team Building: Climbing to New Heights
- Sports Marketing Sales Workshop
- Urban Market Sales Workshop
- PD to GM and Beyond

6:00 - 8:00 p.m. — Radio Opening Reception sponsored by Interep, Westin-Bonaventure Hotel

Thursday, October 13

—SBE—

9:00 a.m. - 10:30 a.m. — AAM V4.2: What's New, and Other FCC/FAA Issues.

10:30 a.m. - 10:45 a.m. — Break

10:45 a.m. - 12:15 p.m. — Broadcast Auxiliary Issues

12:15 a.m. - 1:30 p.m. — Lunch

1:30 p.m. - 3:00 p.m. — Management

3:15 p.m. - 4:15 p.m. — SBE Membership Meeting

7:00 p.m. - 10:00 p.m. — Opening reception - New Otani Hotel & Garden

—RTNDA—

8:30 a.m. - 9:45 a.m. — RTNDA Business Meeting Breakfast

8:30 a.m. - 5:30 p.m. — Student Tape Critiques

10:00 a.m. - 12:00 p.m. — News of the Future

12:30 p.m. - 2:30 p.m. — Luncheon

2:45 p.m. - 4:00 p.m. — Concurrent Programs
- When Sports Is the News
- The Business of the News Business
- Partnerships for Profit
- Look and Sound Like a Pro (Student Session)

4:15 p.m. - 5:30 p.m. — Concurrent Programs
- Pushing the Hot Buttons Without Torching the Product
- We Ain't Writin' Good Copy
- Private Lives of Public People
- Partners in Storytelling (Student Session)

—NAB Radio Show—

9:00 - 10:15 a.m. — Opening Session

10:30 a.m. - 3:30 p.m.
- Money Talks! But How?
- The State of Radio Sales
- Making Satellite Prog. Sound Local
- Doupoly Programming Strategies

12:30 - 5:30 p.m.
- Management Challenge: Motivating in Times of Shrinking Opportunity
- Super Sales Meeting
- Avoiding Million Dollar Libel Suits
- Branding: Creating Loyalty

2:00 - 3:15 p.m. — Featured Presentation - FCC Chairman Reed Hundt

3:30 - 9:45 p.m. — Straight Talk from Industry Leaders
- Radio's new Sales Compensation Systems
- Create Control & Profit from Change
- Soup to Nuts: Programming Tools You Need
- Promotion Exchange Roundtable

Friday, October 14

—SBE—

Radio Sessions

9:00 - 10:30 a.m. — New Technology for Radio - Part I

10:30 - 10:45 a.m. — Break

10:45 - 12:15 p.m. — New Technology for HF Broadcasting

12:15 - 1:30 p.m. — Lunch

1:30 - 3:00 p.m. — New Technology for Radio - Part II

Television Sessions

9:00 - 10:30 a.m. — Planning for HDTV

10:30 - 10:45 a.m. — Break

10:45 - 12:15 p.m. — New EBS Rules

12:15 - 1:30 p.m. — Lunch

1:30 - 3:00 p.m. — RF Systems for HDTV

3:15 - 4:15 p.m. — SBE Chapter Chair's Meeting

4:30 - 6:00 p.m. — HAM Reception

—RTNDA—

7:30 - 8:45 a.m. — International Breakfast

8:30 a.m. - 5:00 p.m. — Student Tape Critique

9:00 - 11:00 a.m. — The Urban Crisis: Covering Crime and Health in America's Streets

11:15 a.m. - 12:15 p.m. — Concurrent Programs
- Living in a 500-Channel Universe
- Crisis Management: When You Are the Lead
- It's Not Easy Being Green

12:30 - 2:30 p.m. — Luncheon

2:45 - 4:15 p.m. — Politics in the Crossfire

4:30 - 9:00 p.m. — Sixth Annual RTNDA Auction and Reception

—NAB Radio Show—

9:00 a.m. - 4:45 p.m. — Indecency: What Is It and What's the Problem?

continued on page 50 ►

So Simple.



DAVID is the uncomplicated FM-Stereo Processor/Generator. Yet, like its namesake, it can more than hold its own against the bigger (and *far* more expensive!) competitors.

DAVID is not a compromise. It features gated, "gain-riding" AGC, split-spectrum compression and limiting, active overshoot compensation and digital synthesis of the composite multiplex output. DAVID makes RDS easy too, with a clean output spectrum, an internal combiner and a pilot sync port.

And, because it's simple, it *sounds* great. Just one knob lets you set the processing anywhere from *transparent* to surprisingly *aggressive*!

DAVID: great sound and great specs for only \$1875. We're serious!

Inovonics, Inc.
1305 FAIR AVE., SANTA CRUZ, CA 95060
TEL: (408) 458-0552 FAX: (408) 458-0554



► continued from page 49

- Key Client Categories - Everything You Need to Know

- Radio Stunts: For Entertainment? Promotions? Ratings? Arrests?
- Format fairs: News/Talk/Sports
- CHR

10:30 a.m. - 3:30 p.m. — Radio's Place on the Superhighway

- Update on FCC Duopoly/LMA Opportunities
- Pushing the Envelope: Where Do You Draw the Line?
- Format Fair: AC

12:00 p.m. — NAB Radio Luncheon featuring Paul Harvey, Courtesy of ABC Radio Networks

2:00 - 7:00 p.m. — Career Tracking

- Capitol Hill Update
- Future of National Business
- Format Fairs: Rock

3:30 - 9:45 p.m. — Contests, Lotteries and Casino Gambling: Making Money and Avoiding Fines

- Retailing: The Mass Marketers Revolution
- The Right and Left of Talk Radio With G. Gordon Liddy and Jim Hightower
- Format Fairs: Country
- Hispanic

Saturday, October 15

—SBE—

Radio Sessions

9:00 - 10:30 a.m. — Digital Technology for Radio - Part I

10:30 - 10:45 a.m. — Break

10:45 - 12:15 p.m. — Digital Technology for Radio - Part II

12:15 - 1:30 p.m. — Lunch

Television Sessions

9:00 - 10:30 a.m. — Digital Technology for Television - Part I

10:30 - 10:45 a.m. — Break

10:45 - 12:15 p.m. — Digital Technology for Television - Part II

12:15 - 1:30 p.m. — Lunch

Joint Sessions

1:30 - 2:00 p.m. — What Broadcast Engineers Need to Know About the NAD83 Coordinate System.

2:00 - 3:00 p.m. — ANSI/IEEE C95.1-1992: heads Up for Broadcasters

6:30 - 7:30 p.m. — Reception - New Otani Hotel & Garden

7:30 - 10:00 — Awards Banquet - New Otani Hotel & Garden

—RTNDA—

8:30 - 9:45 a.m. — Unity '94 Breakfast — Educator Breakfast

8:30 a.m. - 4:30 p.m. — Student Tape Critiques

10:00 - 11:30 a.m. — Concurrent Programs

- Getting Started in Computer Assisted Reporting
- News and the Spin Doctors
- In the Spotlight with Charles Kuralt
- Student Produced Newscasts (Student Sessions)

12:00 - 2:00 p.m. — Foundation Luncheon

2:15 - 3:15 — Concurrent Roundtables

- Keeping Viewers Up for the Late News
- The Law and Your News
- It's Your Shop, Not Your Consultant's
- Religious reporting
- Radio Wars
- How Low Can They Go?
- One Person Bands (Student Session)
- Internships: How to Get Them, How to Use Them (Student Session)

3:30 - 4:30 p.m. — Concurrent Roundtables

- The Law and Your Staff
- Attracting Minority Applicants
- Challenge the Voice Coach
- Learn to Swim Before Hitting the Beach
- The Lone Ranger
- When the Earth Moves
- Public Affairs: Lemons into Lemonade
- Resume Do's and Don'ts (Student Session)
- Writing for Broadcast (Student Session)

6:30 - 7:30 p.m. — Paul White Award Reception

7:45 - 10:00 p.m. — Paul White Award Banquet

—NAB Radio Show—

9:00 a.m. - 2:00 p.m. — Station Improvement in the '90s

- Small/Medium Market Duopoly Sales Strategies
- Large Market Duopoly Sales Strategies
- Morning Show Sidekicks

10:30 a.m. - 4:45 p.m. — FCC Enforcement: EEO and Everything Else

- Radio's Place in the Media Landscape
- Retail Merchandising reality: What Every Manager Must Know
- Programming Trades Only
- Format Fair: Oldies

12:00 - 5:00 p.m. — Duopoly Dynamics

- Securing Your Station's Future
- Top talent Critique of Air Talent Tapes
- Hot Seat: Radio's Critics Answer The Question "If I Were Programming Your Station"

1:30 - 4:45 p.m. — Block Group Coding - Vital to Your Financial future

- Jocks in Space: Networking Your Program
- Music Lyrics

6:00 p.m. — The NAB MARCONI Radio Awards Reception, Westin-Bonaventure Hotel

7:00 p.m. — The NAB MARCONI Radio Awards Dinner and Show, Westin-Bonaventure Hotel

If You Think We Only Supply Cable Harnesses ...



Think Again.

You should see the quality and pricing on Clark Wire & Cable bulk cable and connectors.

Clark Wire & Cable has industry standard audio and video cables available in as many as ten jacket colors. Our customized A/V cables are designed with your needs (and pocketbook!) in mind.

CLARK WIRE & CABLE
1-800-CABLE-IT!
151 S. Pfingsten Road #B
Deerfield, IL 60015

If You Think We Only Supply Bulk A/V Cables ...



Think Again.

Clark Wire & Cable provides custom high quality cables, cut to length and terminated to your specifications.

- Patch Cords
- ADAT Harnesses
- DA-88 Harnesses
- DT-12 Audio Snakes/Harnesses
- RGB Cables
- Remote Camera Cables
- Digital A/V Assemblies
- Complete Facilities
- And More!

CLARK WIRE & CABLE
1-800-CABLE-IT!
151 S. Pfingsten Road #B
Deerfield, IL 60015

MOVING?...

Don't leave us behind!

Mail or fax your current label and new address (with effective date) to:

Circulation, RW,
PO Box 1214
Falls Church, VA
22041

or

FAX 703-998-2966.

Address changes will be processed within four weeks of receipt.

Thanks!



Radio Systems Consoles

“...Such a Deal!”



“Daniel was always a good boy.
And so technical.
Even when he was just a baby
he was always taking things apart.
He works so hard.
I tell him—the people already know
how good your radios are—
so many buttons and wires.
And so complicated.
But to look at it, who would know!

It's so beautiful.
Of course my son makes the best.
But I tell him—
what people want is a good buy,
not a good boy.
He should listen to his old mother.
I don't buy anything if its not discount.
Not like my sons with their fancy cars.
I take public transportation—after 10am
when they let the seniors go for free.

I tell him—people want the best,
but they also want a deal.
I love that—saving money.
I don't buy if I don't get it at discount.
If I were a big shot
company president like my son,
I know how I would sell more radios—
I'd make everyone a deal!”

*Just this once,
Daniel has decided to listen to his mother.
He's offering big discounts
on Mrs. Braverman's favorite consoles.
Just clip this coupon
and fax, mail, or call Radio Systems.
We'll tell you how
to save up to 20% on our products
(...because Mrs. B would never pay list!)*

**Save hundreds of \$\$\$\$\$ during Radio System's "Such A Deal" sale!
Fax or phone for details on our free factory options and dealer discounts.**

Name _____

Station/Company _____

Address _____

Phone/Fax _____

RADIO SYSTEMS INC.

601 Heron Drive • P.O.Box 458 • Bridgeport, NJ • 08014-0458 • (609)467-8000 • (609)467-3044 FAX

from Moscow to NY & from Paris to Tokyo...

MORE STATIONS BUY ARRAKIS!!!



DIGILINK... **THE #1 DIGITAL SYSTEM** **starting at under \$8,000**

- 10 hours of stereo digital audio storage for \$7,995 complete
- Satellite, CD, Tape and Hard Disk Automation
- Simultaneous Play, Record, & Network transfer
- Digital Editor with Waveform Editing for tight production
- Crossfade CD's, sources, and hard disk audio
- Music Scheduling system built in for basic CD automation
- Digital Networking for transfer of audio and schedules

Digilink is the #1 selling digital audio hard disk system in radio today. You can replace your cart machines for live On Air and have an automation system for walk away at the same time! Link over 15 workstations & scheduling computers on our digital network and transfer audio and schedules between your studios.

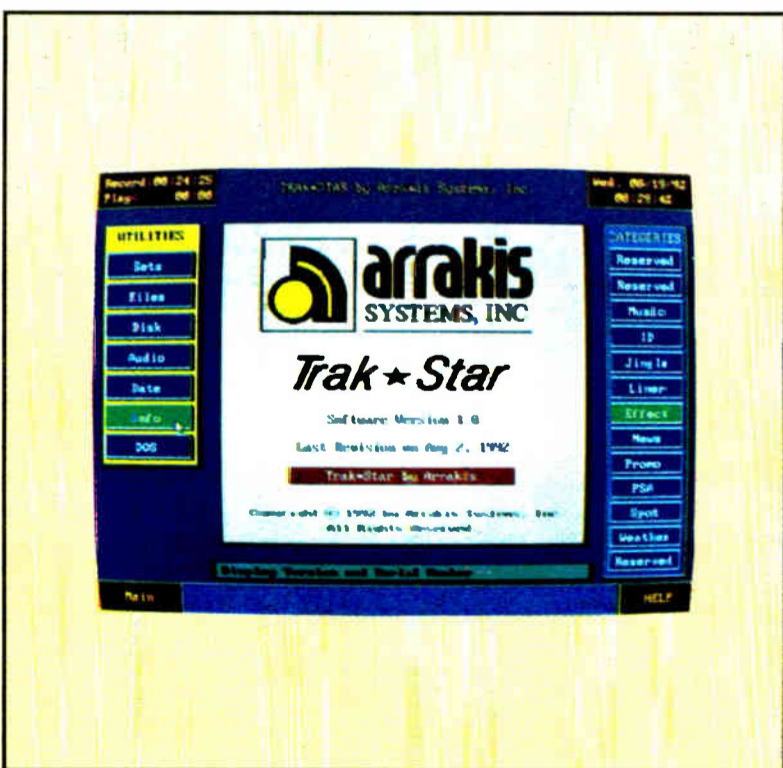

TRAK*STAR-8 **THE 8 TRACK DIGITAL EDITOR** **starting at under \$5,500**

- A digital audio editor designed for Radio production
- Learn to use in minutes, much faster than tape
- Cut, splice, move, and fade up to 4 stereo tracks
- Use Scrubbing to edit with your ears
- Use visual waveform editing to edit with your eyes
- An UNDO button enables you to go back and fix mistakes
- Digital Networking to transfer audio to your On Air machine
- Add Trak*Star-8 software to a Digilink for \$2,000

Trak*Star-8 is the first cost effective multitrack digital audio editor designed for the radio broadcast professional. Fast and easy to use, produce your commercials on Trak*Star and then transfer them in digital straight to the Digilink in your On Air studio. Dramatically reduce production time and save money!!!

2619 Midpoint Drive, Fort Collins, CO. 80525

Voice (303) 224-2248

12,000 Series Consoles



Standard Tabletop Mainframe displayed above

- Totally Modular Console-Input-output-monitor
- Three Mainframe Sizes - 8, 18, 28 input channels
- High Quality Construction-P&G Faders, etc.
- Polycarbonate overlay-for scratch resistance
- VCA Controlled Faders-for ultra reliability
- Universal Mainframe-any module in any position
- Inputs-2 per channel
- Outputs-3 stereo, Pgm, Aud, Utl
- CR Monitoring-stereo Monitor, Earphone, & Cue
- Studio Monitoring-two studios supported
- Talkback-two studios w/monitor dim
- Telephone interface-2 internal mix minus buses
- Timer-60 minute digital up timer standard
- Options-DA module, Remote selector module, Dual Machine Control Module

Deluxe thru-table mainframe displayed below

Typical List Price

\$4,000 - \$7,000

From France...to Moscow...to Japan and Taiwan, and around the world...the 12,000 console is On the Air.

The 12,000 is the #1 selling Arrakis console line from the #1 console manufacturer. With three stereo output buses and two mix-minus buses for telephone interface, the 12,000 can fill any application. The 12,000 also supports a control room and two studios standard. Panning or Mode select are available on the four models of input modules, VCA control of audio delivers reliability and performance.

Quality, performance, and durability make Arrakis consoles the leader around the world.



14 1/4" x 20 3/4"

Arrakis Systems is a world leader in radio studio technology. In Japan, Digilink is a brand name for hard disk audio for radio. For use around the world, the United States Air Force chose the 10,000 series console from among all competitors as its console of choice. When the United Nations needed 6 entire studios with consoles and furniture for a rush shipment to Cambodia early this year, they chose Arrakis 10,000 consoles and Modulux furniture. In Jamaica, Tahiti, and elsewhere, entire factory assembled and tested Arrakis studios are on the air. Around the world and of course in the United States...more stations buy Arrakis for their digital audio, console, and furniture needs!!!!

FAX (303) 493-1076

by **ARRAKIS SYSTEMS inc.**

The Aphex Audiophile Air Chain



Smart broadcasters know that quality sound is essential to attract and keep loyal listeners ... and advertisers.

That's why premier stations around the U.S.A., and around the world, rely on the Aphex Audiophile Air Chain.

This powerful combination of the Aphex *Compellor*® Model 320, *Aural Exciter*® Type III and *Dominator*™ II Model 720 has been improved in several ways with new features and enhanced performance. And, after six years of development, the Chain is complete with the *new Digicoder*™ digitally controlled stereo generator.

The Aphex Audiophile Air Chain allows maximum loudness and modulation while maintaining the natural dynamic feel of the program. Quick and easy to set up, it maintains the same high quality regardless of the type of programming or who is controlling the board. By contrast, other processors need to be tuned for almost every song, and achieve loudness by homogenizing or crunching to the point of pain.

If you want to be a winner in the "no win modulation wars", contact your dealer to arrange a demonstration of the Aphex Audiophile Air Chain. You can't buy better quality at any price.

ARGENTINA—AG Electronica; AUSTRALIA—East Coast Audio; AUSTRIA—AKG Acoustics; BELGIUM—Trans-European Music; CANADA—Erikson Pro Audio; CZECH REPUBLIC—Audiopolis Studio Systems; DENMARK—SC Sound; EGYPT—Alpha Audio; FINLAND—Nores; FRANCE—Cineco; GERMANY—AKG Acoustics; GREECE—Omikron.; HOLLAND—TM Audio; HONG KONG—Ace; HUNGARY—ATEC; INDIA—Pro Sound; INDONESIA—PT Multi Audio Perkasa; ISRAEL—Sontronics; ITALY—Audio Equipment; JAPAN—Otaritec; KOREA—Young Nak So Ri Sa; MEXICO—Audioacustica y Electronica; NEW ZEALAND—Maser Broadcast Systems; NORWAY—Audiotron; PERU—ABBA Trading; POLAND—Europe Sound System; RUSSIA—MS-MAX; SAUDI ARABIA—Halwani Audio; SINGAPORE—Auvi Private; SOUTH AFRICA—Tru-Fi Electronics; SPAIN—Lexon; SWEDEN—LEAB; SWITZERLAND—Audio Tech; TAIWAN—Advancetek; U.K.—Stirling Audio

APHEX *Improving the way the world sounds*SM
SYSTEMS

11068 Randall Street, Sun Valley, CA 91352 U.S.A ■ (818) 767-2929

Compellor, Dominator, Aural Exciter and Digicoder are trademarks of Aphex Systems.

©Aphex Systems

Circle (6) On Reader Service Card

WORKBENCH

Use Imagination and Save the Day

by John Bisset

SPRINGFIELD, Va. Finding unique uses for broadcast equipment is always fun, and depending on the application, might just save the day. Lightning recently took out the headphone and monitor amplifiers in an LPB console. Parts to repair the damage were not readily available, but a Gentner Microtel was. The headphones audio was routed into the AUX RCV jack of the Microtel, and the headphones were plugged into the HEADSET jack.

The result enabled the station to produce several spots so as not to miss the revenue. While talking to the folks at Gentner, they referred me to the Microtel instruction book. In the back are several "alternative uses" and the emergency headphone amplifier is one of them. Another is to use the Microtel as a mic-to-line driver, in case you lose your console mic preamp.

★ ★ ★

Speaking of headphone amps, Analog Devices has a chip you may want to stock for breadboarding projects. The SSM-2135 is a dual channel op-amp that can be used in +5VDC single-supply audio applications. The chip will drive headphone loads of 24 ohms at ultra-low distortion specs. This chip also has outstanding noise specs, so it could also be used in mic preamp applications. If you'd like a data sheet, call Analog Devices at 617-937-1428.

★ ★ ★

John Rohwer at Q94 WZZT in Sterling, Ill., wrote with a suggestion that will take a couple minutes of time and pay off generously for your production staff. John called his device the Lead Vocal De-vocalizer. It's a patch cord with the phase inverted.

John's morning show had the need for music beds to use for song parodies. He had used a home-brew difference amplifier, but found the patch cord to be simpler, and easier to interface with digital sources.

To eliminate production room confusion, you might cut several bands of red or yellow head shrink tubing, so the patch cord is appropriately marked and won't be used for normal work. On some of the music recorded in the '60s, the lead vocal will nearly disappear, permitting your staffs creative juices to take over. One of the best examples is Petula

The patch cord is simple and can interface easily with digital sources.

Clark's "Downtown." John will be glad to demo it for you at 815-625-7527.

★ ★ ★

Ron Bluff is the general manager for Audiovison, a radio reading service for the blind in California. Ron purchased two new Otari MX5050MkIV-2 BIII reel-to-reel machines, and after about five months of use, at the end of a one hour program, the machines would start playing slow. It took awhile to track the problem, because the last thing Ron suspected was the new reel to reel machines.

Removing the pinch rollers, Ron found grooves around the circumference of the pinch roller shaft. After calling the distributor, and Otari, Ron found himself in the endless finger pointing circle.

Although the machines were still under warranty, they were not exchanged. Instead, Ron received endless suggestions like "you're using the wrong type of tape," "change the oil," and "you're using the machines too much." Finally, Ron found a technician at Otari who admitted that some of the new model machines left the factory with the wrong type of lubricant in the oil bearing bronze bushing.

Although warranty parts were sent out, the bushings on the replacement parts looked worse than the originals. Looking into the bearing hole, the effect is as if

someone attempted to install a large screw which scored the bearing surface.

Frustrated with the lack of service on behalf of both the distributor and the manufacturer, Ron subcontracted the manufacture of replacement parts with good results. The shafts were turned to 5mm and an MDS impregnated nylon bushing was provided by Solidur.

It is still unexplained why these brand new machines only lasted months before the pinch roller shafts grooved to the point that the drag slowed the cap-

stan motor. If you've had similar experience, let us know. You might also want to contact Ron Bluff at 909-797-4336.

★ ★ ★

Believe it or not, there are still a lot of the old WX-2C field meters operating in the field. The meter takes the Eveready No. 467, a 67.5 volt battery that can be difficult to locate. One source, which sells the batteries for under \$15 is Electronic Industries in Oshkosh, Wis. Outside Wisconsin, EI can be contacted toll free at 800-558-0222.

★ ★ ★

The subject of tower painting came up recently, and a seasoned veteran explained his procedure for ensuring that the tower was properly painted. At the outset, the painting crew is told that the owner of the station used to rig towers, and will be down to climb the tower and inspect the job when the crew is finished. He even invested in a climbing belt that was stored in a drawer, to add realism to his story.

No more half painted towers, painted insulators, or painting just the underside of the structure so it looks good from the ground—the fear of a complete inspection prevented corners from being cut. I've used a similar line, but actually hired a rigger to climb the tower and inspect the work. Given the costs to have the tower painted, the off air time, and the hassles of getting a crew to return to correct a problem, the couple hundred dollars to send someone up the tower is good insurance.

□ □ □

John Bisset is a principal with Multiphase, a contract engineering and special projects company based in Washington, DC. He can be reached at 703-323-7180. Fax submissions for the Workbench column to 703-764-0751. Printed submissions qualify for SBE Certification credit.

" AEV
CELEBRATES AN
UNPRECEDENT
OUTSTANDING
WORLDWIDE
SUCCESS!

Radio Stations from all continents
enthusiastically praise EXCLUSIVE FM as an
extraordinary and absolutely exclusive event!



AEV Exclusive FM
AUDIO PROCESSOR

ASK FOR IT,
the whole world is asking for it.

ELECTRONIC BROADCAST EQUIPMENT

AEV
ITALY
Phone
39 + 51
950249
950350
Fax
950201

**The world's most capable,
expandable, digital
satellite receiver.**

Ariel

**Proven in
more than
150 installations.
The best
tech support
in the business.
Affordable.**

**Zephyrus for JSA
Zephyrus 700 SCPC
We Repair
& Rebuild all
Popular Receivers
Quick Service!
24 Hour Tech Support**



More and more networks
are moving to Satcom C-5.
Why take a chance with a
less expandable receiver?

Visa/MC/Discover
Leasing W.A.C.



Satellite Systems
(719) 634-6319

Circle (51) On Reader Service Card

Circle (154) On Reader Service Card

FROM THE TRENCHES

by Alan Peterson



New Technology Means More Fun and Mischief

Dear Luci,

Cross your fingers and pray for rain. WINK 104 is up for a Marconi Award as Station of the Year! This is happening hot on the heels of our morning team's success at the Bobby Poe Radio Convention, and our news department scoring another zillion plaques in state competition. So far, 1994 seems to be the year we keep stepping in something.

But don't send the limo down to get us just yet. Some of us are still busy absorbing notes from the recent Pennsylvania Association of Broadcasters (PAB) Annual Conference, and the all-day session on engineering was well worth the time set aside.

Most folks are familiar with Hershey, Pa., as "Chocolate Town, USA," and major attractions such as Hershey Park. Well, just across town is the Hershey Lodge and Convention Center, where the PAB Conference was held in July...coinciding with a weekend computer fair and a Matchbox Cars & Collectibles show in the same building. I got to see several familiar faces turn up in all three venues.

So what made the Engineering Conference worth attending? Let me start with the guy who was on the scene for the debut of *Trench* and now is vice

president of Modulation Sciences, Arthur Constantine (a familiar name from the **RW** masthead of past years). Art was in town to demonstrate Radio Data System coders and receivers his company designs and manufactures, even providing on-air demonstrations via WITF-FM, Harrisburg's public radio outlet.

As you know, RDS has the potential for lots of applications: artist and title ID, "Up Next" information, Emergency Alerts and everything we've read about here in **RW**. But as we also know, "Surely, Good Mr. Murphy shall follow us all the days of our lives," and there is the potential for sick fun and general trainwrecks everywhere, some of which I shared with Art.

For example, who's the lucky soul who gets to enter the RDS information? The slightly off-center overnight jock? If you liked "Twilight Zone" and "Night Gallery," you'll love seeing your RDS display scroll "I'm your radio and I'm going to kill you...oh yes, I am." The high school intern? Great. Get ready for "Hey Beavis, this song sucks! Huh huh huh." The already overworked traffic or continuity director? Better put a spellchecker in the encoding PC, or treat your listeners to "Mor Vaeirty In Th

eMuisce on 99.7" when things get out of hand behind the scenes.

Art found my suggestion worthy enough to enter one or two of my messages into his demo machine during the conference. Why, remains to be seen.

Then came Mike Stelts from Denon, demo-ing the Mini-Disc cart recorder. Mike gave a number of very compelling arguments on behalf of the MD format, and offered up good defense on the compression scheme manufacturers use to squish-down-da-music (even a reference to Herb Squire's Dueling Algorithms paper). I can only speak for myself in suggesting that, with the availability and relatively moderate cost of SCSI hard drive playback systems for on-air use, the MD can easily find a home as a "master-reel" for archiving spots and promos—much as DAT machines are now used.

However, any dedicated fan of classic "Star Trek" can already tell you what the future of audio and data retrieval is going to be: small blocks of maple wood, painted with bright lacquer to look futuristic. From 1966 to 1969, all Starfleet vessels have had these ubiquitous "tapes" shoved into computers, medical scanners, and personal log recorders. Audio quality was questionable, but readable. I don't know the storage capacity or data integrity qualities of maple (much less the relay chatter and that annoying voice, precluding any radio station use presently) but clearly this is an area worthy of further research.

Finally, the monitoring truck from the FCC's Philly office stopped by the back door for us to take a quick look-see. Many of us were quite impressed by the kind of gear available to the dedicated Field Inspector, although some less so: on my way back inside, someone facetiously commented, "That gear's not so great—where's the bazooka?" (a reference to those hi-powered bass drivers we all hear coming twenty blocks away). If this guy needs an audible warning Uncle Charlie is coming, he'd better look over his paperwork now.

Because I won't be attending the NAB radio show this time out, the PAB was as close to the new technology as I'm going to get for now. Too bad. I'd like to be around when they call on us to pick up our Marconi.

'Til Next Time,
-Al

Alan Peterson is Production Director for WTCY(AM)-WNNK-FM Harrisburg, PA 17110. His radio may not be going to kill him, but it's entertaining the thought...huh huh huh...

63 Years Ago

Reprinted from Radio World April 18, 1931. Editor's note: The RW of old, printed for a time in the 1920s and 1930s and today's RW are unrelated except in name.

Short Waves the Most Important to Marconi

In an interview in London, Guglielmo Marconi discussed the study of short-wave wireless which he intends to carry out on his yacht, Elettra, in a short time. In a special cable to the New York "Times" he was quoted as saying:

"The short wave is the most important thing in wireless. It has revolutionized everything. If we can probe the secrets of the ultra-short waves the possibilities will be extremely interesting. But we have not done so yet."

He pointed out that below six meters the signal travels only a short distance and that they do not follow the path of the somewhat longer waves which go up to the Heaviside layer and then are reflected back to earth at distances far beyond the horizon. With the ultra-short waves communication is practically limited to places within sight of each other, he said. The short waves, he said, do not penetrate hills nor do they get around them. His present research deals with the problem of using the short waves over greater distances.

CALLS RADIO STABILIZER

Broadcasting is the greatest cultural influence in American life today, while the influence of the announcer will affect American thought and speech for years, according to Don E. Gilman, Pacific coast division vice president of the National Broadcasting Company.

"Radio's most positive effect lay in stabilizing business during the recent depression."

Products & Services Showcase

For more information on the products shown below, circle the appropriate Reader Service No.(s) on the enclosed Subscription/Reader Service card or contact the advertiser directly.

The CircuitWerkes AC-2 Autocoupler



More Features. Better Price.

- Auto-connect and disconnect.
- FCC Pt.68 registered.
- Two-Year limited warranty.
- LED Indicators for audio clipping, incoming rings and line status.
- Answers on user selectable number of rings.
- Momentary or latching dry contacts at pickup.
- Momentary open collector output at pickup.
- Defeatable pickup inhibit function for cart decks, etc.
- Can be combined with CircuitWerkes DTMF decoder board to form an inexpensive dial-up DTMF remote control.
- Optional ComboLok provides for secured access.
- Suggested list only \$199.

CircuitWerkes

6212 SW 8th Place
Gainesville, Florida 32607
(904) 331-5999
fax (904) 331-6999

READER SERVICE NO. 48

TOWER AND OBSTRUCTION LIGHTING PRODUCTS

FLASHER
FS155-30T



ALARM RELAY
SCR430T



SHORTED FLASHER ALARM
SFA430T

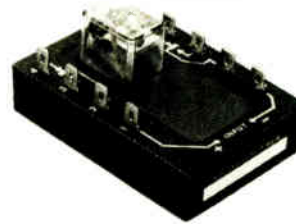
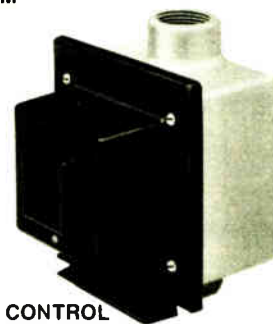

PHOTO CONTROL
PCR11



SSAC offers a complete line of solid state products to control and monitor the lights on communication towers and other tall structures. SSAC solid state products have proven performance and reliability with years of infield use. Flash single or multiple beacons. Sense lamp failure in the beacon, side lamps, or other obstruction lighting with an alarm output. The PCR11 Photo Control with its all plastic housing is ideal for turning on complete tower lighting at dusk (factory calibrated).

PHONE OR WRITE FOR FREE TOWER CONTROLS MANUAL
TELEPHONE (315)638-1300 • FAX (315) 638-0333

SSAC

P.O. Box 1000 • Baldwinsville, NY 13027

FREE



SSAC
SOLID STATE TOWER CONTROLS

Flashers
Alarm Relays
Photo Controls
Shorted Flasher Alarms
3 Phase Voltage Monitors

P.O. Box 1000 • Baldwinsville NY 13027

READER SERVICE NO. 155

MARKETPLACE

Recently Introduced Products for the Radio Broadcast Professional

Upgrade Moseley TRC-15 to Computerization

The ITO-178 from Hallikainen & Friends offers the ability to easily upgrade an existing Moseley TRC-15 remote control to computerized operation.

The ITO-178 includes a special controller card that plugs into the expansion slot of any IBM-compatible XT/AT class machine. The controller then uses the data port on the TEL-171 digital telemetry adapter to access meter reading data, channel select and raise/lower commands. A user I/O port provides two I/O ports to monitor or control devices at the studio location.

Software included with the package allows you to run the system right out of the box. A configuration feature of the software allows you to match the system to the unique needs of your transmitter site. The software provides automatic limit checking, logging and control functions.

For information, contact Harold Hallikainen in California at 805-541-0200; fax: 805-544-6715; or circle Reader Service 29.

User-Friendly Hard Disk Automation System

The DigiStation digital hard disk automation from The Blue Group replaces conventional automation and cart machines and does much more.

A user-friendly screen prompts for basic data such as spot number, client name, etc., and then a simple keystroke starts the source machine, transferring the audio to the DigiStation hard disk.

DigiStation can work in a variety of situations. With a satellite network, it handles all spots and liners and programming. In a live-assist situation, the DigiStation aids the DJ by playing all spots. The DJ simply pushes one button and an entire stopset goes on air.

The DigiStation uses Dolby AC-2 compression and a 32 kHz sample rate to conserve space on the hard drive.

For information, contact Ben UMBERGER in Florida at 813-442-1665; fax: 813-531-4487; or circle Reader Service 52.

Automate with Existing Audio Sources

Economics and convenience are the driving forces behind the BA-1 automation

Universal Autolocator With MMC

CuePoint from JLCooper Electronics is a universal autolocator that fully supports MIDI Machine Control (MMC) and is fully compatible with the Alesis ADAT, Fostex RD-8, Tascam DA-88, traditional analog tape decks, video tape recorders and many hard disk recorders.

CuePoint is a compact remote control unit that controls up to four MMC-compatible tape recorders and software programs. It offers conventional tape transport controls, a shuttlewheel and incorporates track enable and track grouping functions. In addition, it provides quarter-frame-accurate auto-punch in and out and 99 locate points. Locate points can be captured on the fly and then edited and recalled as necessary.

system from Broadcast Automation.

The BA-1 system was developed to use existing audio sources—minimizing the need for expensive dedicated equipment. It features dynamic relay and TTL level I/O control and monitoring capabilities and is orchestrated by your office PC. Broadcast Automation tailored its software to respond to user-defined configuration files, dynamically altered event logs and interrupt driven subroutine calls.

With a modular architecture, the BA-1 is easily expandable in increments of 16 relays and 24 digital I/O ports. The software also includes a modular design to accommodate your unique equipment setup.

The software runs on any Intel 80286 or higher processor. It accommodates up to 86,400 preprogrammed events per day, 604,800 events per week at a rate of one per second. Software runs as a standalone DOS application or multitasked through Windows on another machine.

For information, contact Jon Moore in Tennessee at 800-874-9629; fax: 615-529-2680; or circle Reader Service 33.

Automated CD DJ System

The CDJ Pro from Gefen Systems is an automated CD disk jockey system fitting the needs of today's broadcasters. The system allows a program manager to create custom playlists for a format while still giving DJs complete real-time access to the entire CD library.



It features a SMPTE reader/generator with a large, easy-to-read LED display. It can be driven by incoming SMPTE or MIDI time code or work as a master synchronizer, sending SMPTE and MIDI time code at the same time. An optional dataCARD expansion card allows CuePoint to slave to the Alesis ADAT without wasting an ADAT audio track for SMPTE.

For information, contact Chuck Thompson in California at 310-306-4131; fax: 310-822-2252; or circle Reader Service 103.

Based around an Apple Macintosh computer, CDJ Pro software and hardware, and CD jukebox-type disc changers, the CDJ Pro can be configured to completely automate the entire on-air process, including commercials, station IDs and jingles.

Gefen recently added PC computer compatibility to its CDJ Pro broadcast music management system, allowing

stations with Windows-based PC systems to interface existing computer systems with the Macintosh-based CDJ Pro broadcast system. Another recently introduced interface integrates the CDJ Pro to the 360 Systems DigiCart II.

For information, contact Hagai Gefen in California at 818-884-6294; fax: 818-884-3108; or circle Reader Service 150.

Fiber Optic Cable and Accessories

Fiber optic cable, as well as fiber optic cable accessories, are now available from Clark Wire & Cable.

Among the offerings are tight buffer breakout cables for indoor applications; tight buffer multiple application cables (MAC) for premise distribution applications and loose tube; and gel-filled cables for outdoor aerial, duct and buried applications.

The high-performance cables meet NEC 770-6 requirements for plenum (OFNP) and riser (OFNR) and are also CSA FT4 and FT6 listed.

Additional fiber optic cable products are also available from Clark, along with the necessary connectors, couplers and boxes.

For information, contact Susan Clark in Illinois at 708-272-9889; fax: 708-272-9564; or circle Reader Service 80.

Digital Modulation Monitor/Analyzer

The Belar FMSA-1 FM digital stereo modulation monitor and analyzer provides comprehensive stereo FM monitoring in a one-rack unit package. It also provides and AES/EBU digital audio output via an XLR connector on its rear panel. Also on the rear panel are left and right analog XLR outputs.



One alphanumeric LED display accesses all menus and settings while two other numeric displays indicate values for left and right channels. When used with The Wizard and its PC software version 2.0, the FMSA-1 can be remotely accessed and controlled via PC and modem. It also can be interfaced with automated test equipment for automatic proofs-of-performance. The digital output allows separation measurements of up to 80 dB.

For information, contact David Hisch at telephone: 610-687-5550; fax: 610-687-2686; or circle Reader Service 127.

A revolution in radio...

D-RADIO

- All digital signal path
- Networked information system
- Fully assignable virtual console
- Automated rundown scheduler
- From the Australian Broadcasting Corporation – inventors of D-CART

EXPERIENCE THE REVOLUTION!

PREMIERING!

See D-RADIO and D-CART at World Media Expo Booth #3862

ABC-DIGITAL
 GPO Box 9994, Sydney
 NSW 2001 Australia
 CALL COLLECT 24 HOURS
 Tel: +612 333 2660
 Fax: +612 333 1413

Building and Using Loop Antennas

Part II of II

by Chris Scott

BOWLING GREEN, Ky. In the first part of this series, general AM emission measurement techniques were discussed along with the critical nature of the receive antenna and its attendant antenna factor.

Now we examine design and construction of two loop antennas: a shielded, untuned receiving loop to be used in the field with a spectrum analyzer, and an unshielded transmitting loop used to generate a frequency independent standard

electrical noise pickup, with proper site selection, an interfering signal can be nulled typically 20 dB, and antenna factor is easily generated using the method described below.

The loop also is an excellent general purpose pickup: positioned near an AM radiator, it provides a nice clean sample to a scope, spectrum analyzer or frequency counter—all of which are useful to have available when "proofing." Normally the sensitivity of the loop increases directly with the speed that the lines of flux cut across the windings; this translates to a 6 dB per octave increase, which is useful for harmonic measurement.

More sensitivity makes the lower level harmonic energy easier to resolve. Actual measurements proved this to hold well until parasitic reactance becomes a significant portion of the loop impedance.

Our shielded loop was constructed of 1.25-inch square aluminum tubing with a gap at the top to prevent the shorted turn effect. Two turns of number 18 insulated wire were wound inside, using wooden collars to maintain spacing from the walls.

More turns can be used, but the increased inductance and stray capacitance will reduce the frequency at which antenna factor anomalies begin. Often, for communications purposes, the loop winding is resonated with a parallel capacitor, greatly increasing the Q and the output. Although this can be useful for improving the antenna sensitivity and selectivity for harmonic relationship measurements, this should be avoided for bandwidth testing because it's easy to bandpass out the sideband energy you're looking for.

Although theoretically balance will be adequate by using shielding, we grounded the winding mid-point and used a broadband 1:1 transmission-line transformer for enhancement. A good measure of balance is null depth; this loop averaged

slightly more than 20 dB.

The standard-field antenna consisted of a single 20 centimeter diameter turn of 1/16-inch x 1/2-inch aluminum bar supported by steatite bushings installed at the top of a shielded meter box. The loop is fed through resistors and a balun.

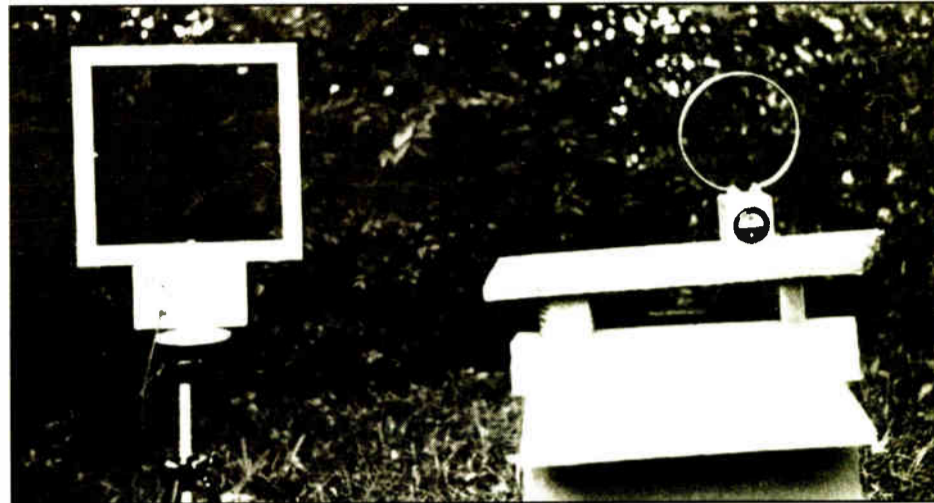

Using the loops in the field.

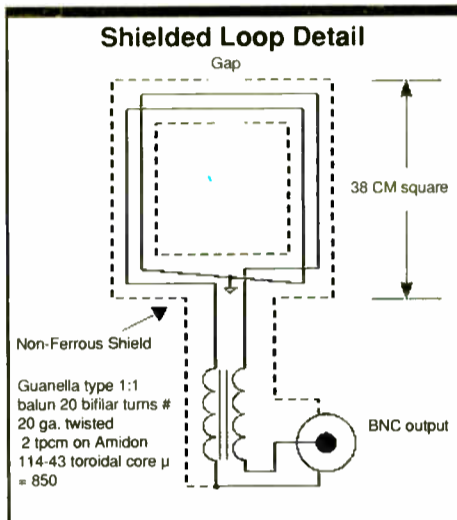

field, to calibrate the former. The technique described is very similar to the way NIST calibrates AM field strength meters.

Shielded loop antennas respond primarily to the magnetic component of the RF field, and provide good directionality in the form of a figure eight with nulls at right angles to the plane of the loop. Compared to an amplified (E-field) whip, empirical tests prove the shielded loop to reject substantially more electrical noise.

The key benefits of the loop stand up well for AM emission testing. Minimal

Although a Schottky diode would probably be a better choice, a 1N34A diode served adequately as a meter detector and was calibrated to center with 100 milliwatts at one megahertz.

A reliable antenna factor can be accurately produced using the near-zone magnetic field of a small constant current circular loop. This is similar to the standard method NIST uses to calibrate low and medium frequency field-strength meters.

Because the loop size is very small compared to the wavelength, the antenna current remains essentially constant throughout the conductor, resulting in the radiated near-zone magnetic field being almost constant over the decade, 0.5 to 5 MHz. This field does not follow the inverse distance rule, falling off rapidly beyond a couple of meters.

We spaced the loops two meters apart center-to-center which proved to be a

good compromise between field intensity and sensitivity to placement repeatability. The reference radiator was mounted one meter above ground on a wooden platform, the shielded loop on a tripod at the same height. Although this "mini-antenna-range" setup is considerably more tolerant to the presence of adjacent structures than VHF antenna testing, reflective objects should be kept to a distance at least three times the spacing between antennas.

We excited the reference radiator with 100 milliwatts of harmonic-free RF, using the internal meter as the working reference. At this distance our FIM-41 field strength meter indicated 6.0 mV/m with coplanar (normal) alignment, and 21 mV/m when aligned coaxially, the way NIST does it.

According to the FIM, this field varied less than 3 percent over the decade in question. With this standard-field estab-

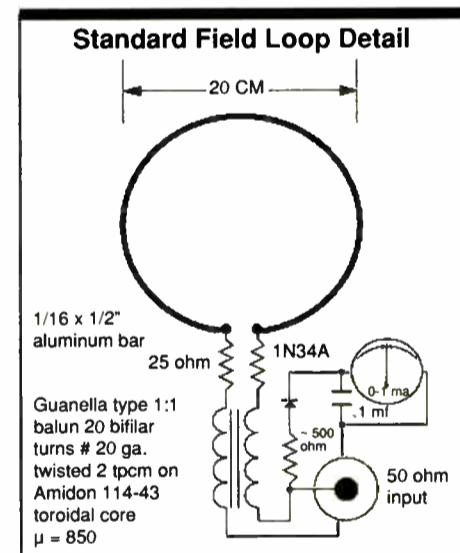

lished, calibration of small aperture magnetic field antennas properly positioned becomes pretty straightforward. If constructed exactly like our shielded loop, the 6 dB per octave rule will hold well until slightly above 2 MHz, where some variation will be recorded. When combined with both a modern spectrum analyzer and a notch or bandpass filter, an accurately calibrated antenna completes the package necessary to begin proofing.

A tripod supported the loop in the field, and the entire apparatus is guaranteed to generate interest from passers-by who must surely believe that you're DF'ing for Nazi spies.

□ □ □

Chris Scott is the chief engineer at the Public Radio Service of Western Kentucky University. He specializes in RF Systems, and somehow manages to keep the network on the air most days. He can be reached at 502-745-3834, or via the Internet: SCOTTCR@WKUV.XI.WKU.EDU.

AXS (Ax'-sess)... Jocks Love It!

AXS is an entirely new approach to digital audio controllers. It starts with superb audio using the premium quality apt-X™ system. AXS is easy to learn, easy to use, and powerful beyond words.

AXS is a modular design that begins as a simple cart replacement and grows to any combination of CD, hard disk, satellite or specialty programming with ease.

AXS has all the sophisticated feature options including device independent multi-channel background audio record and replay. Macro programming makes tough to run event sequences easy. Software drives a powerful programmable real time IOMAP.

Jocks love AXS: A fast 99 page, 28 button Jock F/X panel that can be time linked and remote wired is standard.

Use a software driven four-channel stereo audio switcher with on-screen control or the powerful eight-channel dual-buss routing switcher, or include both if you wish. AXS is controlled through a trackball, touchscreen, keyboard, buttonbox, telco or remote modem. **AXS systems...**

From \$6000.00 using your 486 computers and hard disks.



AXS™

The Management

800-334-7823 817-625-9761

FAX 817-624-9741

P.O. Box 1-36457 Fort Worth, TX 76136

1700+ Stations • Our 14th Year

Value



R A D I O M I X E R
P R O D U C T I O N M I X E R

Many broadcasters know that PR&E provides the consoles and systems for market-leading radio stations and network facilities throughout the world. Unfortunately, with a client list that reads like a "who's who" of the industry, some broadcasters with more modest budgets feel that PR&E consoles are out of their reach. We'd like to introduce you to Radiomixer™, a first-class on-air console at a coach-class price.

Created by the same team of designers and engineers responsible for major-market "showcase" facilities, Radiomixer offers the reliability, performance, and many of the features of our world-famous BMX, at a price guaranteed to satisfy the most demanding budget. Using top quality components, Radiomixer delivers advanced features including the most elegant telephone mix-minus system available, along with uncompromising sound quality and reliability.

And when you add multitrack production power on top of the Radiomixer's standard features, you have Productionmixer, the most affordable high-performance production console in broadcasting. There isn't another console family in their price class that can offer the total value of Radiomixer and Productionmixer.

Why settle for less, when you can have genuine PR&E features, quality, reliability and service? Call today for your full color brochure.

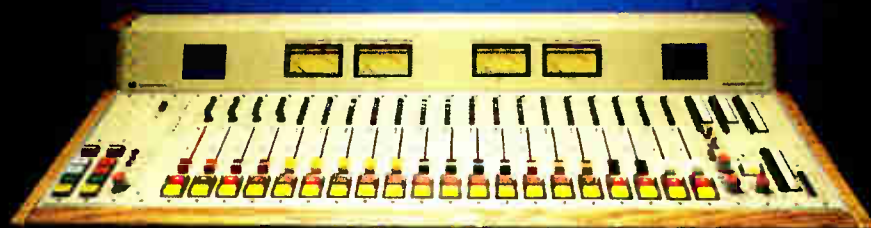

Pacific Recorders & Engineering Corporation
2070 Las Palmas Drive, Carlsbad, CA 92009
Tel: 619-438-3911 Fax: 619-438-9277 GSA: GS-03F-2057A

DESIGNS THAT MAKE THE DIFFERENCE

Circle (66) On Reader Service Card
World Radio History

LINE-OUT

Music Festivals Are Good Radio Material

by Bruce Bartlett
with Jenny Bartlett

ELKHART, Ind. If you want to draw lots of listeners to a local musical event, it helps to promote the event on the air. Here's how one station ran such a promotion.

This past July, WVPE-FM in Elkhart, Ind., put together a promo for the Elkhart Jazz Festival. The station did more than the usual blurbs, though. The promotion people added remote broadcasts, live recordings, and local news stories that grabbed listeners' attention. As a result, the festival drew bigger crowds than ever before.

Basically, the station carried on three activities:

- Remote broadcasts from the festival site.
- Live recording playback of festival artists.
- The airing of stories on the festival and local music companies.

Jim Biddle, a DJ and producer at WVPE-FM in Elkhart, explained how the job was done:

Remotes

"Every year we do a remote at one of the festival venues. We take along a

mixer, put a Marti on the roof, and shoot the Marti's signal back to the station. During the remote feed, we read the schedule of the performers and give some color stories on the musicians. Often you can hear the bands playing in the background. The studio cuts to the remote feed several times during our regular jazz programming.

If something goes wrong at the remote, we communicate by cellular phone.

"We also use the standard sports signal. The studio people monitor us all the time, and I'll say at the remote site, 'If you can

hear me, turn down the air signal for a second.' When a band starts playing at the remote site, we have to shout into the microphones.

"So next year, we plan to set up in a quieter area. We also hope to interview some of the musicians. And we'd like to take stereo feeds from two stages and put them on the air—a live broadcast of the festival music."

Live recordings

Biddle explained further: "In addition to the remotes, on-location recordings are part of the promotion. I thought they would be a good musical sampling of what people could hear at the festival. We recorded some of the bands on DAT, ran the tape back to the station, timed it out, did some editing, and put it on with our regular programming.

"To introduce each tape, we said something like, 'Last night at the Elkhart Jazz Festival, the Agostino's House Band was playing. We have a little sample of that for you. You can catch the band today at the jazz festival, as well as Milt Hinton and Marian McPartland.'

If something goes wrong at the remote, we communicate by cellular phone.

"To record the bands, I used a Crown SASS-P MKII stereo mic and a Sony portable DAT," Biddle said. "I set the mic close to each band to pick up their natural acoustic sound and not pick up the P.A. Previously, I had asked the band's permission to record. Back in the studio, I recorded start IDs on the DAT tape so the on-air person could quickly find the cuts to play."

News stories

As another promotion, Biddle said the station also put together some festival stories which were played after the national news broadcasts. "During the last ten minutes of our network news feeds, the network affords us time to cut away to air a local story," he said. "So we put in news pieces that pertained to the festival, and also switched to the remote. We produced pieces on the local museum, local musical instrument manufacturers, and the festival organizers."

A lot of listeners enjoyed the local flavor of the stories, according to Biddle. Not only was there a lot of music to be heard, there were a lot of historic pieces dealing with the musical instrument companies.

"Elkhart is full of them, such as Selmer, Conn, Gemeinhardt, Blessing, and UMI. The promotion took two months of planning and some sleepless nights, but was well worth it. We heard a lot of good feedback. People would say, 'I was listening to your station, and all the talk about the festival made me come out here.'"

□ □ □

Bruce Bartlett is a microphone engineer and technical writer for Crown International, and the author of "Practical Recording Techniques," published by Howard Sams. Jenny Bartlett is a technical writer. Bruce can be reached at 219-294-8388.

Touchscreen Plays Music and Spots Instantly from Hard Drive

Play Anything at a Touch

Nothing else makes radio as fast or easy as having all your songs, spots, sounders and sweepers start with your fingertip—**always on-line and ready** to play from hard disk. And nothing else is better for fast, exciting radio than the **new Scott Studio System!**

Here's how it works: Six buttons on the left of the computer touchscreen play what's on your program log. Your songs, spots, promos, PSAs and live copy come in automatically from your music and traffic computers. You can rearrange anything by touching arrows (at mid-screen), or opening a window with the entire day's log. On the right, **18 hot keys** start unscheduled jingles, sounders, comedy and sound effects **on the spur of the moment.** You get 26 sets of hot keys for your jocks' different needs.

12:21:38A Copyright 1994 by Scott Studios Corp.

*Air 3:56	Can You Feel The Love Tonight Elton John :15/3:57/C HIT HM0105 10:14:47 #1 for 3 Weeks in July, 1994	:14	Delete Del	Jingles & Spots 7	Music Library 8	
Start F2	But It's Alright Huey Lewis & the News :12/2:44/F HIT HM2608 12:24:40	Auto 6	Jingles A	Applause B	Sweepers C	Bumpers D
Start F3	Win It Before You Can Buy It Q: The Sound of the Tones :00/0:18/C PRO TO2214 10:21:14	F7 Move Up	Weather E	News Open F	News Close G	Rimshots H
Start F4	McDonald's 2 for \$2 Special JT Q: Thru Saturdays Only. :00/1:00/C CM DA1103 10:21:33	F8 Move Up	Morning Jingle I	Oldies Jingle J	Legal ID K	Animal Noises L
Start F5	Bob's Bargain Barn BW Q: At Westland & East Park. :01/1:00/C COM DA4310 10:22:01	F9 Move Up	Top 8 at 8 M	Crowd Boos N	Happy B'day O	More Events 9
Start F6	Uptempo Jingle Q: Kiss FM. :00/0:06/C JIN DA1037 10:23:01	F10 Move Up	Contest Theme Q	Crowd Cheer R	Weather Service S	Options 0

ABCEFGHIJKLMNOPQRSTUVWXYZ

12:21:38A Without You
Maroon 5
:00/3:57/F HIT HM0105 12:21:47
#1 for 2 Weeks in March, 1994

World's Fastest Requests!

Touch the Music button at the top right of the main screen to see our "Wall of Carts" with 1,000 songs (or more) **on-line!** They're displayed by title, artist, year, length, category, or any way you like. Touch the song you want and Scott Studios' digital audio hard disk plays it **instantly.**

In addition, all your comedy bits, spots, jingles, promos and PSAs have their own "Wall of Carts" so they start immediately. Or, you can pick any unscheduled song, spot, sweeper or promo and put it anywhere you want in today's log.

1, 2 or 3 Touchscreens

Teams of personalities can add touchscreens to share control. Jocks choose whether to handle sweeps themselves or let the Scott System sequence automatically.

Simple and Paper-free

Weather forecasts, live tags, promo copy, contest winners' lists and programming memos automatically pop up on your Scott System's screen. As an option, we can also work with your news wire to update and display selected weather, news and sports copy.

The Best Digital Audio

When spots, promos, PSA songs, or any other digital audio events are recorded, they're immediately playable in **all** your Scott System air studios. Nobody wastes time carrying carts down the hall or redubbing spots for additional stations.

Scott Studios will even pre-record your music library from CDs at no extra charge. You choose double- or triple-overlap playback (or more) while recording.

Improve Your Production

Scott Systems pay for themselves in increased efficiency on-the-air and in production. Our graphic waveform editor quickly cleans up out-takes and works wonders with big productions.

Disk Prices Plummet

Compared to mere months ago, hard disk prices have dropped dramatically! And Dave Scott has more digital audio and automation success and experience than anyone else in the business! We also offer excellent leases. Call for details.

Scott Studios Corp.
13375 Stemmons, Suite 300
Dallas, Texas 75234 USA
(800) 330-3004

Products & Services Showcase

For more information on the products shown below, circle the appropriate Reader Service No.(s) on the enclosed Subscription/Reader Service card or contact the advertiser directly.

**COMPOSITE
STEREO
DISTRIBUTION
AMPLIFIER**



Distribute full composite baseband as easily as audio! Our Model CLD-2504 gives you four independent outputs for your stereo and subcarrier generators so you can drive multiple exciters without composite level changes and impedance matching problems. Full 3 year warranty. For details, call your authorized Modulation Sciences Distributor, or the Composite Audio Authority...

modulation sciences, inc.
12A World's Fair Drive • Somerset, NJ 08873 USA
Voice (908) 302-3090 • Fax (908) 302-0206
Toll Free in USA (800) 826-2603

READER SERVICE NO. 36



**Econco
REBUILT POWER TUBES**



Approximately One Half
the Cost of New

3,000 Hour Unconditional Guarantee

Call for Our Price List

Econco 1318 Commerce Ave. Woodland, CA 95695
Phone: 916-662-7553 Fax: 916-666-7760 Telex: 176756
Toll Free: 800-532-6626 From Canada: 800-843-8841

READER SERVICE NO. 182

ONE GOOD TURN AFTER ANOTHER

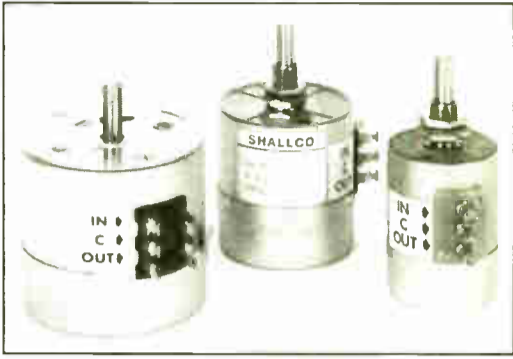

Is the success story for Shallco/Daven style step attenuators. Over 50 years of combined service to the broadcast industry. You can depend on us for reliable products and service. Request New Catalog A20 for additional information.

SHALLCO, INC.
PRECISION ELECTRICAL COMPONENTS
P.O. BOX 1089 • SMITHFIELD, NC 27577 • TEL 919/934-3135

READER SERVICE NO. 18



**CD 100 • X Compact Disc
Adapter-Amplifier**

Matches any consumer compact disc player or cassette deck to broadcast console input. Only \$99.00 FOB factory or from any broadcast dealer.

Russ Friend & Associates
342 N. Sunnyside
Clovis, CA 93611

Phone 209-298-6838 FAX 209-298-8270
Turntable Parts/Felts
Russco, Collins TT-200, Sparta

READER SERVICE NO. 205



**CUSTOM COUNTRY MUSIC
CD LIBRARIES**

NO MORE BUYING EXPENSIVE "GENERIC" MUSIC LIBRARIES.
PICK THE SONGS YOU WANT

DCproductions
1-800-789-3472

FOR DEMO CALL
912-872-8111 OR
912-246-1100



**TIME, TEMPERATURE &
WEATHER COMPUTER**

A REAL REVENUE BOOSTER
FOR YOUR STATION

THESE ARE ACTUAL
SYSTEMS MAKING
\$990 EACH PER MONTH!

READER SERVICE NO. 219

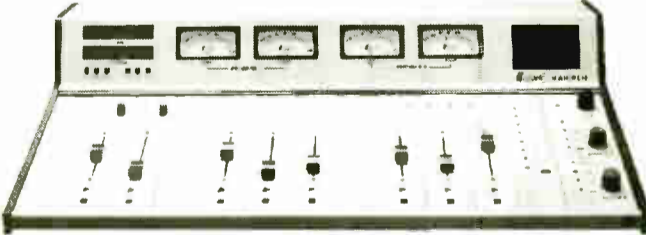

Why Compromise?

Get affordable features for any format!

Do you faint at the cost of a full featured console but find that budget consoles can't support the complexity of your station's tight format?

The Mariner console's software based channel mixers can easily supply a simple machine control to the most complex automatic sequencing and gain control scheme, all at a modest price.

And our digitally controlled analog signal path has a full, clean sound that is second to none while ensuring trouble free service for years to come.

Starting at \$3900, the Mariner series consoles give you today's technology at yesterday's prices.

Logitek Call: 800-231-5870 or 713-782-4592 for your nearest Logitek dealer

READER SERVICE NO. 104

**EVEN THE BEST CAN
BE MADE BETTER**

Introducing the new
MINI-MIX 12A
THE COMPACT MIXER WITH A
COMPACT PRICE FROM THE
QUALITY LEADER



\$3499 12 Channels
25 Stereo Inputs

Service & Affordable Quality for Over 23 Years

**AUTOGRAM
CORPORATION**

1500 Capital Avenue (214) 424-8585
Plano Texas 75074-8118 1-800-327-6901
FAX (214) 423-6334

READER SERVICE NO. 21

DIGITAL DOMAIN

Should Radio Drive the Info Highway?

by Mel Lambert

LOS ANGELES Much has been made in the popular media of a major revolution that's hovering just around the technology corner: The Information Superhighway.

While I remain unconvinced that the timing and impact of this new, high-capacity pipeline into our homes will be quite as dramatic as the pundits would have us believe, I have been pondering the myriad ways in which this development might influence the medium- and long-term future of our radio community.

A yen for information

There can be no escaping the fact that the average consumer, particularly one under 30, has a voracious appetite for information. And not just the conventional types of data that might previously have been restricted to printed media; in these days of multiple cable entertainment and informational channels, we are smarter and better informed about the world around us.

The Information Superhighway, we are told, will revolutionize the delivery of visual, sonic and text information, by not only pipe-lining several megabits of data into the home via twisted-pair or fiber-optic connections, but also enabling the same conduit to provide bi-directional communication with information suppliers.

Aside from movies-on-demand and related video services, these high-capacity links will allow users to access information interactively; one application will be customized newspapers, with specific searches being made of central news files, so that only the data and analysis we are interested in can be fed directly to our in-house terminals or low-cost printer.

The average consumer, particularly one under 30, has a voracious appetite for information.

My only reservation with such a scenario is that the majority of consumers do not know what they are interested in until it starts winging its way to them in a finished format, via the traditional media outlets. At which time they bestow their approval or disapproval by stating tuned, or searching the airwaves for a more suitable entertainment.

For radio, I predict that the availability of additional diversions to the more familiar informational sources will force broadcasters to re-assess their role. News and talk radio will be able to capitalize on its archive sources, and possibly offer a tailored service that provides interactive analysis of the impact that a major breaking story

might have on a variety of listeners.

Music stations might be able to offer instant access from a large digitized library of top 100 tunes, for example, which the consumer could program in a pre-selected or random order, with or without announcements. (But with commercials interspersed amongst the tunes, so that the broadcaster might recoup the

additional capital investment.)

But there are two additional ways in which the technology of a superhighway might be exploited by the radio community. To support the provision of a high-capacity data link to our homes, trunk systems will be provided between urban and rural areas—in much the same way as telephone companies use branch connections from each subscriber, through a local exchange, to the long-distance connection, another local exchange and hence to the person or company we are calling.

Redundant capacity on these major data highways between local hubs—and probably based on optical fiber ATM and similar network systems running at data rates approaching 2.5 gigabits per second (Gbps)—could be used to provide enhanced communications between regional studios and a central master control, or between stations within a major group.

Economies of scale

I suspect that as the new generation of information providers begin to zero in on the specific needs of a wider user base of consumer markets, broadcasters can effect an economy of scale by pooling, rather than dissipating, their resources.

One obvious way that might be achieved

would be through the sharing of pre-recorded material in a centrally-located server, accessed via high-speed, bi-directional data links. Or maybe national advertisers and their ad agencies will jump at the opportunity to deliver full-bandwidth audio on demand, rather than resorting to the ISDN- or telephone-based delivery systems currently being used to on-pass commercials to radio stations.

And with access to low- to medium-cost, high-bandwidth links between regional centers, the opportunity presents itself for the production of niche commercials, whose marketing message can be prepared quickly for a small, focused audience.

Finally, the availability of high-capacity links within a community means that remotes and other off-site productions can be linked to the station more easily, and with higher quality audio in both directions. Again, once the Superhighway trunk links are established in the near future, radio can benefit from additional capacity and become more connected with its audience.

A great deal will change in the way we currently present radio programming to a mainly passive audience. The more innovative and adventurous broadcasters are already exploring ways of competing with the new information providers.

Radio, as will be readily appreciated, has more than 70 years of day-to-day experience with responding to the needs of local audiences. The advent of the Information SuperHighway will bring more competition for the audience's attention. But, at the same time, it also opens up exciting possibilities for different types of material, utilizing both over-the-air and direct-delivery channels. It may well be time that we begin to look to the future. It's here now.

□ □ □

Mel Lambert has been involved with the production and broadcast industries on both sides of the Atlantic for more than 15 years. Now principal of Media&Marketing, a Los Angeles-based consulting service for the professional audio industry, he can be reached at 818-753-9510.

45,000 WATTS WITH NO COMBINER ALL IN LESS THAN 21 SQ. FT.

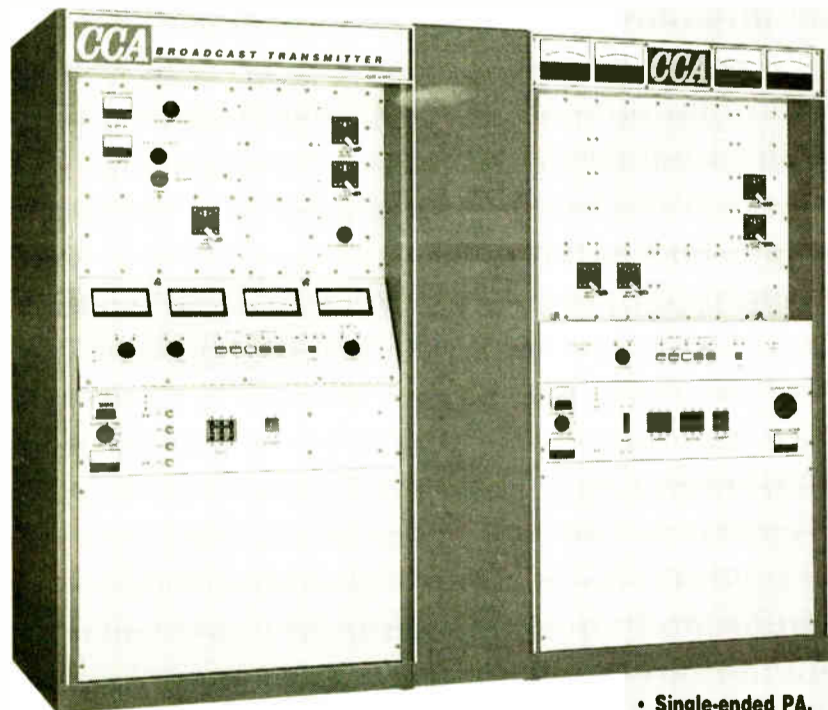

CCA

CCA Electronics, Inc.

P.O. Box 426 • 360 Bohannon Road
Fairburn, Georgia 30213 USA
(404) 964-3530 • FAX: (404) 964-2222

- Single-ended PA.
- Conservatively rated.
- Driver may be connected directly to antenna in case of emergency.
- DC grounded-grid triode.
- 24-hour service, 365 days-a-year.

Circle (111) On Reader Service Card

See Us At WME Booth # 2620

World Radio History

GEPCO INTERNATIONAL

Audio, Video & Broadcast Cables

2225 W. HUBBARD ST., CHICAGO IL 60612-1613
(312)733-9555 FAX (312)733-6416 (800)966-0069

Circle (109) On Reader Service Card

See Us At WME Booth # 737 & 739

You used to have excuses for using a consumer CD player. Perhaps you wanted audiophile sound quality, but then you had to put up with pre-historic user controls. Maybe you wanted an inexpensive player, but then you were saddled with awkward operation, marginal reliability and even worse sound.

YOU HAVE NO MORE EXCUSES.



The DN-650F Professional CD Player changes everything. Denon has combined their legendary audiophile sound quality with powerful features developed specifically for studio and broadcast applications. Industry-proven professional controls include true instant start, auto cue-to-music, index search and a full complement of professional input/outputs, such as balanced and unbalanced audio, digital out, and a GPI interface. In addition, you can format these features for your specific applications.

The Denon DN-650F. Professional performance, economical price. And no excuses.

DENON
The First Name in Digital Audio

The Next Generation Digital Audio System

Satellite • Automation • Live • Studio Assistant



Live Assist Screen Pictured

Time	Station	Program	Duration
00:	ALABAMA	BORN COUNTRY	03:07
03:	HIGHWAY 101	WHO'S LONELY NOW	03:09
06:	ALAN JACKSON	CHASIN THAT NEON R	02:58
09:	THE JUDDS	LOVE CAN BUILD A	04:04
13:	THE BROWN ADOBE	SALSA SPECIALS	00:30
14:	WYBU LEGAL ID	SPRING MARATHON ID	01:00
14:	LEWISBURG PHOTO	SPRING FEVER SALE	00:30
15:	CARLENE CARTER	COME ON BACK	02:46

User Programmable Database Search and Store Parameters

LPB SALSA - \$8,995

386DX33 PC System with 1 Gigabyte Hard Drive
Open-ended architecture, always upgradeable
Simultaneous Record and Play of audio
Stereo and Mono audio

User-controlled variable audio overlap for live-sounding segues
Accepts downloads from all standard traffic and music scheduling systems
Provides a 31-Day historical log of everything that aired and when
System support available 24 hours a day, 365 days a year

Live Studio Assist (included)

Full color and easy graphics
Control completely by mouse
Play any hard drive audio immediately or via schedule
Search spots and music by up to 6 different categories
Identification of bad audio files - before they air

Satellite Automation (included)

Up to 15 stereo satellite networks, unlimited events/hour
Record for delayed broadcast - automatically
21 Format clocks - changing automatically as you wish
Up to 8 control outputs for other sources or equipment
Walkaway operation with full confidence

You Can Rely On LPB.



Lease the LPB SALSA for \$226.94 per month*

Contact us for complete details on walkaway operation!
World Media specializes in assisting stations in setting up complete walkaway systems -- remote control -- FCC rules --
-- EBS compliance -- ATS sites -- logging -- traffic -- billing
You can sound live...while the SALSA pays for itself!

World Media, Inc. PO Box 552 Forest Va 24551

-Consulting Engineering-Studio and RF equipment sales and turnkey construction- over 70 stations constructed!
(804) 525 0900 Fax (804) 525 6716

*60 month lease - normal credit requirements apply

Running Radio

**Prevent Sexual
Harrasment,
Part II**
See page 70.

Your Resource for Business, Programming & Sales

New Radio Formats Rooted in Past

by Alex Zavistovich

WASHINGTON A popular complaint about the current decade is that it lacks identity. I disagree. Granted, it has no clever positioning phrase, like the Me Decade or the Reagan Era. No, its identity is far more

The current revival trend, of course, is the '70s, reinforced by the wild success of Woodstock '94, which signaled an end to Americans' obsession with '60s nostalgia.

Popular music substantiates this theory. Bands like Counting Crows, Pearl Jam, Stone Temple Pilots, Blind Melon, Soundgarden and others in the so-called "modern rock" and AOR genres owe more to musicians like Van Morrison and Blue Oyster Cult than they do The Cure. In more mainstream radio programming, super-

school and college years—there are plenty of psychographic studies to support that hypothesis. So for folks 30 and over, you are talking about music from 1975-1980; under 30, the critical time frame is late '70s to early '80s.

As I mentioned earlier, many programmers understand the critical '70s connection. It is the understanding of that connection that has led to the suddenly popular "ARROW—All Rock and Roll Oldies" format, created by CBS and exemplified by its station WARW in Washington, D.C. WARW's IDs even go so far as to explain the station's recipe for success, focusing on music of the '70s (for the 30-plus crowd), with some late '60s (a bid for the younger Baby Boomers) and the best of the early '80s (for some of the older Generation X audience).

See, it makes good financial sense for a station to accommodate the 30-

plus demographic segment. People in their 30s have been in the work force for at least ten years now; many are well-established in their careers, with substantial discretionary income. They may be looking to upgrade their car, plan an elaborate vacation or even buy a new home. In many ways, they are more important to a station than the broader demographic that includes the graying Baby Boomers.

The simple truth is that music of the '70s is the "Music of Your Life" for people in their 30s and early 40s. It also explains the exploding popularity of Modern Rock as a format—after all, most people in their 30s first heard modern rock artists during their college days (that is, the late '70s). These same people now tune in to Modern Rock or Adult Alternative stations to instantly recapture their lost youth.

The Washington Post of August 11 featured a fascinating story on the trend in East Coast dance clubs for '80s nostalgia. The college-age and early 20s men and women who populate the nightspots are

continued on page 74 ►

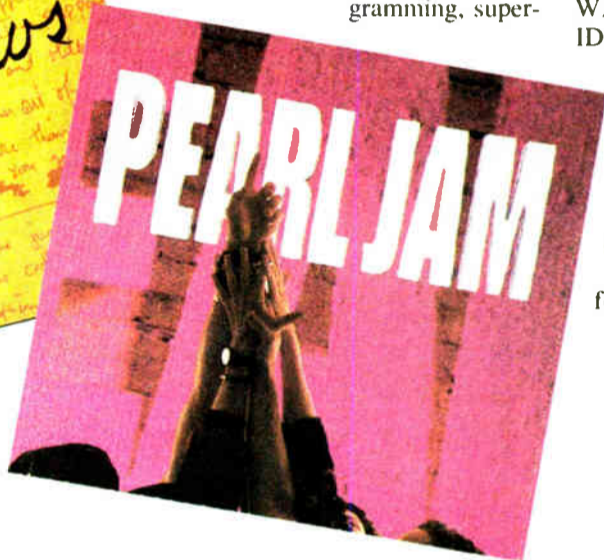
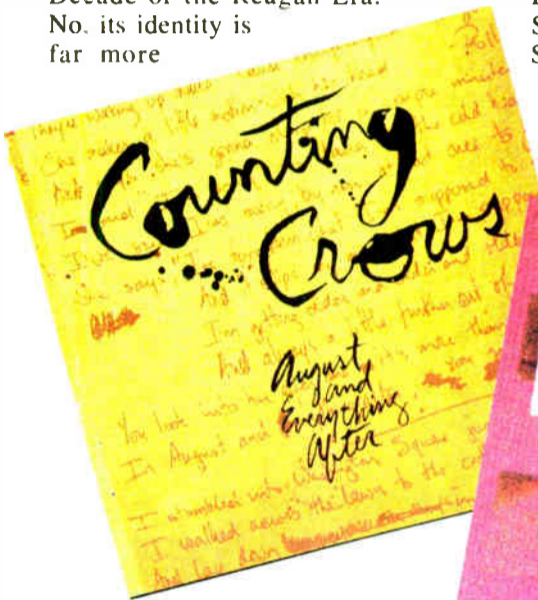

The new bands heard on the radio today, draw inspiration from yesterday's artists.

subtle, but it exists nonetheless. I believe the '90s can accurately be described as the Nostalgia Decade.

Read the clues: The Rolling Stones; Crosby, Stills and Nash; Neil Young and Crazy Horse; Woodstock '94. The first half of the 1990s has been one continuous tribute to the decades that came before it, in fashion and music.

groups of the '70s have resurfaced in new Oldies programming that captures the feeling of AOR stations of 15 years or so ago.

It is a matter of simple arithmetic, really. Say your station is looking to improve its ranking with the 18-34 demographic. Understand first that a person's strongest memories are tied to his or her high

AP Makes All News Radio Affordable.



Thanks to AP All News Radio, stations everywhere can afford to take advantage of one of radio's most successful formats. Call The Associated Press for details.
800-821-4747

The **HOTTEST** and **CLASSIEST** way to make your Radio Station . . .

**STAND
OUT!**

The J.R. Nelson Collection Volumes 1&2
Market exclusive beds & EFX package designed for the **ULTIMATE** image!
Each GOLD-MASTERED CD contains **99** cuts of the hottest beds ever heard before!

OUT OF THE BOX

Lee Logan/KSAN-FM San Francisco
Jim Graci/KBS G-FM Seattle
Ken Carson/WROQ-FM Carolinas
Tim DeCapua/WLKK Erie
That's Country Oldies Classic
ROCK & News/Sports/Talk!

**REALISTIC
1-TIME ONLY
BUY-OUT FEE
STARTING AT
\$ 300**

*This is the
one you've
been
saving your
money for!
**IT'S REALLY
WORTH IT!***

**FAX/PHONE FOR DEMO/RATES:
(IN THE U.S.) 1-803-268-6521**

Circle (161) On Reader Service Card

Circle (25) On Reader Service Card

Rules for Writing Creative Radio Spots

by Ronald Pesha

QUEENSBURY, N.Y. I love turning in the contract and spot order at the office, knowing the copywriter will do it right. If you are the announcer, don't you love getting copy ready to go at the door of the production room rather than just a fact sheet? But what if you must write the copy? The

majority of radio stations live in small markets where skeleton staffs predominate. You have to do it.

Radio sells, but radio sells better with strongly-written copy. Learn to write powerful copy. Improve your spots dramatically by structuring your copy effectively, using pictures, and avoiding the meaningless phrases which your competition uses

all the time in its advertising copy.

Spot Structure

Every advertisement, radio, television, or print, includes all or most of these elements:

Attention grabber, or hook. You must get their attention first.

The problem. Your listeners want food, or a good time, or a

good price on the lusted-after barbecuer or snowblower. The copy offers fulfillment of that problem, that need. Life sucks if you do not have a brand new ski jacket, or if your underarms stink.

The solution. Use the sponsors product or service to obtain the benefits.

Visualizing results. The testimo-

nial. Feel good after eating the hamburger.

Call to action. Do it now. Location of store, etc. If you sold it, you closed it. Now close it in the copy by saying what to do and where to go.

Use Pictures in Radio Copy. In radio the pictures are in the brain rather than on a screen. Stimulate the listeners imagination. Read over your just-written spot. Do images, such as, skiing down powder-fresh, tingly cold glistening snow exist? Unless you've never seen snow, you cannot help but picture it. It is easy placing pictures in radio spots. Just use adjectives and adverbs. Not just a salad, but a crisp, fresh salad.

Avoid generalizations. Be specific. "Many colors to choose from" is a meaningless phrase. Instead, write "Choose red, or blue, or orange." Something specific. Something imaginable.

Better yet, use adjectives. Write, "Choose brilliant red, sky blue, or intense orange."

Keep it simple

Get to the sponsor immediately. An actual radio spot started this way:

"Now that the good weather that has been so long awaited has finally arrived, many families will be taking to the water to enjoy the sport of boating."

Bunk. Start with "Jack's Marina makes boating fun and safe with sale-priced life preservers. Use sounds of a happy beach crowd mixed with boat or water sounds in the background. There is your mood-setter, scene-setter, your picture.

The rewrite also opens with the sponsors name, deals with a problem, supplies factual information, and hooks the listener with a specific sale price. All in an 11-word first sentence.

Avoid "Imagine this," or "Imagine you are skiing down a slope..." If your pictures are good, you shouldn't need to tell your listeners to imagine it.

Avoid cliches. I mean phrases like: Snug as a bug in a rug; Warm as toast; Sweet as honey; Raining cats and dogs. Each of these is a cliché. You sound stupid writing them—or reading them, if you are the unfortunate announcer who must read copy which some incompetent wrote.

Broadcast advertising has developed its own cliches, such as these: A bewildering array; Designed with you in mind; You'll be glad you did; A store full of values; Can't be beat (which is also negative); A real bargain; Something for everyone, and of course, Many to choose from.

Notice that these broadcast

OUR DIGITAL AUDIO WORKSTATION IS NOW PERFORMING WITH THE FOLLOWING GROUPS



ADAT is a registered trademark of Alesis Corp.



Vermont Public Radio

Sam Sanders, a happy Foundation 2000 user since January, estimates that he has cut his production time in half.

Our unique Edit Controller looks and feels just like the recorders you work with every day—no keyboards, front-end computers or mice to slow you down. The built-in touch screen shows you a wave form picture of your sound for instant visual reference. There's even an ASRC option so that you can convert one sample rate to another.



Audio Mixers, New York

Fred Venitsky (pictured) and Jimmy Regan have the distinction of owning and operating the most used Foundation 2000 on the planet.

Foundation 2000 is fast and easy to use. Audio scrubbing is so clean, you'll swear you're rocking reels. Edits are seamless. Fades are smooth and glitch-free. Plus, you can specify the "Light Pipe" for direct interface with the popular ADAT™ and RD-8™ digital recorders.

FOUNDATION 2000LS

Designed specifically for broadcast production, this random access recorder/editor features the speed, the ease of use, and uncompromising audio quality of Foundation 2000—for less than \$15,000! It's the same dedicated user interface with touch screen display, real time operation, event based editing, wave form display, and expandability to a full Foundation 2000 at any time—the only workstation of its kind to offer this important feature. Test drive the high performance Foundation 2000LS in your studio. Call 1-800-7-FOSTEX or 212-529-2069 today to schedule a demo.



Fostex

advertising clichés lack pictures. Can you clearly picture a store full of values?

Use the right vocabulary

First prize for the most overused radio expression goes to: You will find...

Copywriters often characterize people as finding merchandise. Listen to the radio for a period of time and count how many times you hear the word find.

Sometimes find combines with an awkward prepositional opening:

At Smiths you will find... Or this version: At Smiths you can get... Or: At Smiths they have...

Avoid Pronouns: Write, "Smiths offers special prices," not "they offer special prices." Remember that nothing is more important in a spot than the sponsor's name. If the distracted listener gets nothing else from the message, perhaps he/she will at least hear the name of the sponsor. Continually repeating the sponsor's name may sound a bit awkward, but you are writing advertising, not literature.

Be prudent, too, using the words "our" or "we." These words are most suitable for spots voiced by actual representatives of the business, not by an anonymous announcer at a radio station.

Write in the Present Tense. Copywriters use "you can get" almost as often as "you will find." Change "You can get your favorite color at Smiths" to "Choose your favorite color at Smiths."

Now examine the copy you just wrote. If you used "will" or "can" anywhere,

change it to the present tense. Never use "will" or "can." Note that "would" is a form of the word "will." And "could" is a form of the word "can." Avoid using all four of these words to improve the immediacy and incisiveness of your writing.

Personalize Your Spot. Remember that you talk to an individual person. Talk

Use Factual Information. Intelligent, sophisticated, affluent people want to spend, so supply the hard data they need to make up their minds where to shop. Using factual details about the merchandise or service advertised also helps reduce dependency on those meaningless clichés.

Improve your spots dramatically by structuring your copy effectively.

directly to that person. Write, "Choose brilliant red, beautiful blue, or stunning orange, your favorite color."

Fortunately for copywriters, in English the word "you" is both singular and plural. "You feel important at Smiths, choosing your favorite color."

Avoid phone numbers. Unless the client insists. When did you last write down a phone number off the air?

Be credible

Streetwise consumers mentally turn off much advertising, so don't tell them that it is incredible. Writing "incredible" and "unbelievable" not only uses clichés, but listeners might believe that its unbelievable.

For example, "Too good to be true," implies that prices which are too good to be true usually are. Wouldn't you be suspicious if someone offers a used car to you at an "incredible" and "unbelievable" low price which is too good to be true?

But avoid using too much information. Sell one item or a very few, not many. Avoid lists of merchandise (unless the account insists). Lists work well in print media, not on the air.

Write Positives, Not Negatives. Change "Don't be hungry," to "Enjoy a great salad." Change "Don't be cold this winter" (also passive) to "Feel warm this winter." Not be warm, but feel warm. "Be" is passive. "Feel" is an active verb. And add the adjectives. "Feel cozy, snugly, toasty warm this winter." Write that copy for effectiveness, thereby increasing sales, and feel warm this winter.

□ □ □

Ronald Pesha is Associate Professor of Broadcasting at Adirondack Community College in Queensbury, N.Y. He worked in commercial broadcasting for 17 years, holding various jobs, including, copywriting, announcing, programming, engineering and traffic. He can be reached at 518-793-4491.

63 Years Ago

Reprinted from Radio World July 4, 1931. Editor's note: The RW of old, printed for a time in the 1920s and 1930s and today's RW are unrelated except in name.

Rapee New Director Of National's Music

Erno Rapee, 40, is the new general musical director of the National Broadcasting Company. As an Hungarian immigrant youth he played for his meal ticket in a cafe in New York City. For more than thirteen years Rapee was associated with Roxy (S. L. Rothafel).

Rapee became a leading influence in the synchronizing of standard music and modern compositions for motion pictures. He scored and composed theme songs for many picture successes, including "Charmaine" of "What Price Glory," "Diane" of "Seventh Heaven," and "Angela Mia" of "Street Angel."

Trade-in Sets Asked As Gift to the Blind

How to accomplish the most good with an obsolete receiver was suggested to radio listeners of the nation, when a plea from the New York Association for the Blind for discarded trade-in radios was broadcast during the weekly concert of the Philco Symphony Orchestra.

The appeal for old sets, made on behalf of institutions for the blind throughout the country, was made at the suggestion of the New York Association, which requested time during the regular Philco broadcast for its plea.

Now 24-hour operation at a shadow of its former costs.

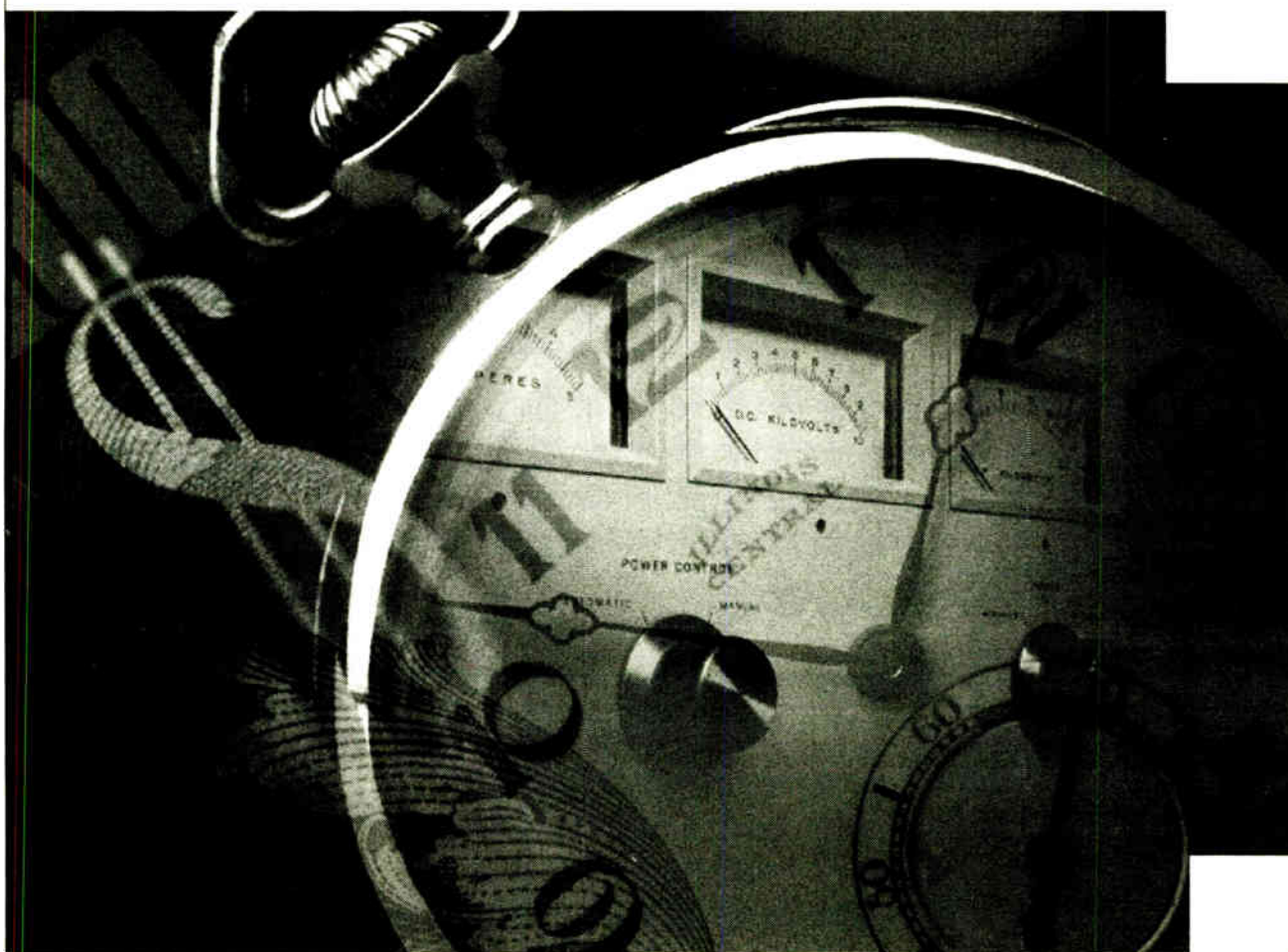

If the idea of 24-hour operation seems anything but profitable, consider ACCUWATCH.

ACCUWATCH is a fully automatic, FCC approved, transmitter and extended remote control service. Whether you're using automation tapes or satellite-delivered programs, ACCUWATCH keeps your profits in-house and not out-the-door with labor costs. For as little as \$250 a month you can literally leave your transmitter unattended anytime, day or night, while still providing your listeners with continuous, uninterrupted broadcasting. The Accuwatch designated control point system operates in complete compliance with all FCC rules for ATS, EBS, and emergencies such as lightning or power outages.

With ACCUWATCH you can legally operate 24-hours a day at a shadow of former costs and make your profits more than just a remote possibility.

For more information, contact Dave Woodworth at the Moody Broadcasting Network at 800-621-7031.

AccuWatch

Go First Class to Europe.

Take your listeners on a weekly, two-hour journey through Europe via *THE EUROPEAN HIT SURVEY* hosted by Bobby Sicilia. This musical extravaganza, designed in a magazine format brings you a weekly profile of the latest Pan-European hits. It is also loaded with updates on current music trends in Europe, interviews with today's hot artists, entertaining industry news, and information about European lifestyles. Your listeners will appreciate this exclusive program because it is "First Class" all the way.

The
EUROPEAN
Hit Survey

Hosted by Bobby Sicilia

Don't keep your listeners waiting! For more details call Sound & Stations USA at 214-444-2525.

Circle (49) On Reader Service Card

World Radio History

SALES SAVVY

Phone Blitz Can Pad Bottom Line

by Bob Harris

DALLAS I will bet you can increase your sales production and therefore your income by at least 10 percent with better use of the telephone. Let's take a look at a few ways to improve your phone power.

The phone blitz

This is an old technique, but it works. I have seen stations put as much as \$75,000 worth of business on the books with a one-day phone sales blitz. Here's how to do it.

The concept is simple. For one entire day, the sales force does not leave the office. Instead, they man the phones making sales calls, offering a special "package" at an attractive price.

To be successful, there must be significant planning by management to make it happen. Schedule a day for the phone blitz so all sales people can clear their schedules. All sales people must be on the phones all day and cannot leave the office that day to make in-person sales calls.

Sales management must put together a sales package that is very attractive yet one that maximizes all available inventory. Normally these packages include commercials in all-day parts and spread over the full seven-day week. Only one package at one price is offered on phone blitz day. Everyone is selling the same package.

Create additional incentive for sales people by offering prizes for the phone blitz. The most packages sold, the first package sold, the most packages sold in the first hour and so on.

Arrange for lunch to be brought in: have drinks (soft drinks, juice, bottled water, coffee) and snacks available during the day. Have support people and sales management standing by to help the sales people make it happen. Set up a big tally board with the names of the sales people and chalk up the sales successes as they happen.

Part of the planning process involves the sales people preparing the list of prospects they will call. The calls should include regular customers, existing prospects and totally new prospects.

Cold calls

I know many sales people consider cold calls, whether in person or on the phone, something they should avoid. However, I'm sure that you have bought something, or at least tried something, that has been offered to you in a cold call.

People may not like getting them or making them, but the calls are a proven and effective means to an end. A cold call is simply a way of introducing yourself to an individual with whom you have had no previous relationship.

The cold call should be regarded as the first step in the sales process. You determine your prospect's need and then match those needs to your specific products. Think of the cold call as the start of the longer sales process; you're just trying to establish who you are so when you call again you are not a totally unfamiliar voice or name.

Here are three simple rules for cold calling:

- 1) View the cold call as the beginning of the sales process.
- 2) Do your homework and have a strategy for each call.
- 3) Cold call consistently.

What you don't want to do in a cold call is sound like you are reading from a

script. You must know your product (your station and its attributes), and you must prepare. To be successful, you must research your prospect and his business. If you haven't done your homework, you are not going to make the sale, whether on the phone or in person.

Make it your own

As you prepare for your cold calls and your introductory conversation, be sure to inject your personality and your words. You can't use someone else's words if they don't sound right to you or you don't understand them.

In sales, personality is very important. You want to sound intelligent and relaxed. If you are reading words that are not yours, it won't work. And remember there are no magic closes, either in person or on the phone. You are just trying to move this potential sales relationship along to the next step, hopefully at least to an in-person appointment.

Selling is a numbers game—the more sales calls you make, the more you are going to sell. So make your cold calls every day, keep your prospect pipeline full. We all know that if we don't have new prospects in the works our business

will suffer down the road.

You don't have to be a sales superstar to be very effective at cold calling. You don't have to memorize anything, and you certainly don't want to alienate anyone with a hard sell approach. Just use your common sense and follow a few simple rules, and you'll see increased sales as a result.

□ □ □

Bob Harris is a sales and marketing consultant to the food manufacturer, food broker and radio industries, based in Dallas, Texas. His services to radio stations include in-market sales training, sales seminars, sales promotion projects and hands-on new business development. He can be reached at Harris Marketing Group, 3422 Flair Dr., Dallas, TX 75229; phone: 214-902-8552; or fax: 214-956-9885.

SEND YOUR AUDIO ACROSS THE STREET OR AROUND THE WORLD™

When you think digital audio, think California Digital. We provide satellite/digital technology to make all these options available at low cost:

- ▮ Syndicate your top personality or format
- ▮ Add affiliates - gain revenue sources
- ▮ Share programming, talent and costs
- ▮ Off-site announcer feeds
- ▮ Create events with remotes
- ▮ CD-quality live coverage of news, sports, and concerts

California Digital offers expertise in:

- ▮ Digital Satellite Networks - C or Ku
- ▮ Regional, National, International Nets
- ▮ Remote Broadcasts
- ▮ Rugged Fly-away Systems
- ▮ Custom Ku Power Control Software
- ▮ System Design & Engineering
- ▮ FCC Licensing; Installation and Training
- ▮ Equipment sales, leasing and financing
- ▮ Switch 56 & ISDN program distribution

REVOLUTIONARY NETWORK DELIVERY SYSTEM

See the daX™
World Media Expo Booth 2838

CALL:
CALIFORNIA
DIGITAL AUDIO

West Coast Office (805) 523-2310 Fax (805) 523-0480
Midwest Office (612) 631-5064 Fax (612) 631-5010

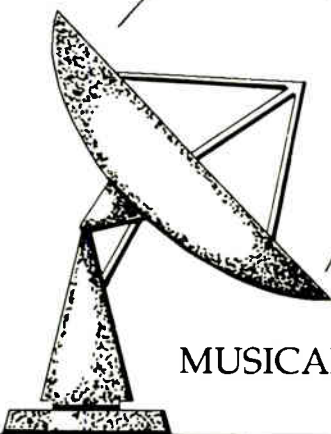

MUSICAM™

**MAKE MONEY BY CREATING A
MUSIC PROGRAMMING NETWORK!**

MANAGER'S NOTEBOOK

Keep Your Employees Safe from Harassment

by Sue Jones

BURKE, Va. As we discussed in the last *Manager's Notebook*, sexual harassment is no joke in the eyes of the courts. More and more, the courts are awarding significant sums of money to victims. Looking the other way or ignoring signs of sexual harassment can cost your station several thousands, if not hundreds of thousands, of dollars in legal fees and compensation to employees whom the courts determine are victims.

What can you do to prevent sexual harassment lawsuits or problems at your station? There are no guaranteed solutions. However, prevention is the best tool. There are several steps you can take to build awareness and provide guidance to your managers and staff about sexual harassment. The following is a list of actions that have been effective for others.

Square one

Prepare a sexual harassment policy. Define sexual harassment and provide examples of what is considered unacceptable. Your policy should be strongly proactive against sexual harassment. Clearly state that the station will not tolerate any form of sexual harassment.

Establish a complaint procedure. The procedure should ensure confidentiality. In addition, it should provide effective remedies. For example, a remedy may include "disciplinary action up to and including dismissal" for sexual harassment offenders.

Publish a sexual harassment policy. Distribute the policy to all staff members. Post it on the community bulletin board. Include it in your employee policy manual. Send out periodic reminders of the policy and examples of inappropriate behavior.

Train your department heads and employees. Hire a local consultant or

corporate training firm for a half-day seminar for all staff. If you "think" this is too expensive, compare it to the cost of one lawsuit and the negative publicity that would be broadcast and printed. The seminar should explain the liability to the station and the potential personal liability.

Prompt and thorough

Investigate claims. For your policy to be creditable to your staff as well as to the courts, you must be prompt and thorough in investigating claims. All claims should be treated as valid until the full set of facts are known to the complaint investigator(s).

The claims process must be confidential. Such claims are sensitive to both parties involved. A person could be falsely accused of the deed. A victim may feel that his or her privacy has been further violated if others know. Both sides could feel that exposing the information would be detrimental to his or her reputation and/or professional opportunities. Certainly no one wants to be the subject of office gossip.

To get you started in developing a sexual harassment policy/training plan, the following examples should be included in all harassment policies/training seminars:

1. Definition of a Hostile Work Environment — unwelcome sexual or sex-based behavior that creates an offensive, hostile or intimidating work environment and that adversely affects an employee's ability to do his or her work.

2. Definition of Sex-Based Harassment — behavior that denigrates or ridicules an employee or is abusive because of his or her sex. For example, the statement: "I don't want men working for me because they are not dependable." is overly critical of men's work and should be avoided. Men sabotaging a female co-worker's work and ridiculing a woman's ability to

do her type of work could also be interpreted as sexual harassment.

3. Definition of Subtle Sexual Harassment — unwelcome sexual or sex-based behavior that is allowed to continue could create legal liability for the station. Subtle sexual harassment is not legal but it is a practical term that can be used to recognize the early stages of sexual harassment.

Avoid confusion

Give clear examples of acceptable and questionable behavior, as well as examples of known sexual harassment.

Examples of behaviors generally not

Provide clear examples of what is acceptable and what is questionable behavior.

considered sexual harassment:

- One-on-one performance counseling
- Touching that could not reasonably be perceived in a sexual way, such as a quick pat on the back
- Encouragement
- A polite complement
- Friendly, non-sexual conversation

Examples of behavior that many people would find unacceptable and thus could be found to constitute sexual harassment:

- Violating a person's personal "space" by standing closer than appropriate or necessary for the work being done
- Whistling or cat calls
- Intimate questions about a person's personal life
- Lewd or sexually suggestive comments, foul language or cursing
- Leering, staring or looking a person up and down
- Repeated requests for dates if the person indicates he or she is not interested
- Sexually suggestive touching or

gesturing sexually

- Hanging around or following a person

Courts of Law have determined that the following examples of behaviors are always considered sexual harassment:

- Sexual favors in return for employment rewards
- Threats if sexual favors are not provided
- Sexually explicit pictures, posters, calendars and/or software programs
- Sexually explicit comments
- Obscene letters or comments
- Using status to get dates
- Sexual jokes

- Calling a person hunk, stud, doll, babe or honey

- Turning work discussion to sexual topics
- Making sexual comments about a person's

clothing, body or looks

- Making kissing sounds, howling or smacking lips
- Telling lies or spreading rumors about a person's sex life
- Blocking a person's path
- Restricting, hindering another person's movements
- Sexual and/or derogatory comments about men/women on coffee mugs, hats or clothing
- Making facial expressions such as winking, throwing kisses or licking lips
- Letters, gifts and/or materials of a sexual nature
- Touching the person's clothing, hair or body
- Touching or rubbing oneself sexually around or in view of another person
- Brushing up against a person
- Hugging, kissing, patting or stroking
- Patting, goosing, caressing or fondling
- Tearing, pulling, yanking a person's clothing
- Exposure

The most severe forms of sexual harassment include:

- Sexual assault
- Forceful grabbing
- Fondling
- Forced kissing
- Rape

Several other examples could be cited, but these will provide a reference point. One basic guideline should be, "If you are uncertain if an action could be interpreted as sexual harassment, don't do it."

Ignoring the potential problems and hoping they will correct themselves or go away is inviting trouble. Today's legal environment has changed significantly over the last five years.

A savvy manager is in tune with the changes, understands their impact on a station's operation and bottom line and implements the policy and procedures to adapt to the current environment. A clearly written sexual harassment policy, complaint procedure and swift action on claims will reinforce your commitment to enforcing the laws and go a long way in preventing legal action.

□□□

Sue Jones is a senior manager for Computer Data Systems Inc., in Rockville, Md. She can be reached at 703-323-0491.

THE SECRET'S OUT—DIGITAL FURNITURE

**MODULAR
FLEXIBILITY
WITH A
CUSTOM FIT**

*We Offer Six Elegant
Lines of Studio Furniture*

4153 BONITA STREET
SPRING VALLEY, CA 91977
PHONE 619/698-4658
FAX 619/698-1268

MURPHY
STUDIO FURNITURE

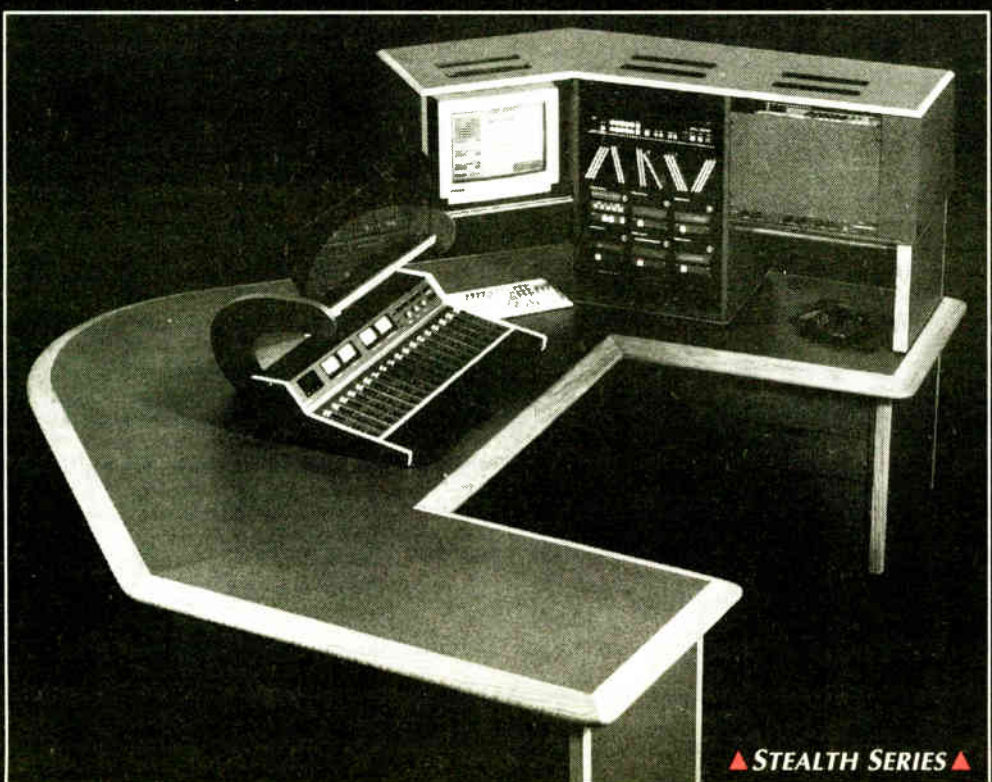

▲ STEALTH SERIES ▲

Circle (28) On Reader Service Card

World Radio History



AUDIOARTS ENGINEERING Model 8400 Distribution Amplifier

Two 8-way or Four 4-way Distribution

POWER

1 2 3 4 5 6 7 8
LEFT

1 2 3 4 5 6 7 8
RIGHT

SECURITY

THAT'S WHY YOU NEED A DA

NATURALLY you'd expect the design experts at AUDIOARTS to provide it. After all, we've built hundreds and hundreds of audio consoles; we've got the track record.

The AUDIOARTS 8400 is now the only DA with performance specs good enough to keep up with our other designs.

COMPONENTRY: High quality of course! Individual 15-turn output gain trims for precise calibration, fully regulated DC supply (current protected), low magnetic field power transformer, high quality FR4 glass epoxy circuit boards (with solder mask coating to reduce the chance of foreign particle shorts) plus clearly marked component legends for easy service.

FEATURES: It's got what's needed! It's **DUAL FUNCTION:** the 8400 can be used as an eight output stereo DA or easily configured as four 1x4 DAs (using simple rear panel jumpers)—sixteen outputs total, each with its own front panel gain trim. It also has **separate connectors** for every input and output. This allows for easy wire changes in the field, rapid troubleshooting, and further avoids the conductor pinching that plagues screw terminals.

The 8400 has the componentry, performance specifications and interconnect system that make it the obvious choice for your facility. At AUDIOARTS we've got the engineering know-how; **benefit from our experience!**



AUDIOARTS ENGINEERING

7305 Performance Drive, Syracuse, New York 13212 (tel 315-452-5000 / fax 315-452-0160)

Prague FM Takes to the City Streets

by Charles Recknagel

PRAGUE, Czech Republic How did an Irish FM radio station launch one of the most successful new private radio stations in Eastern Europe?

Through market research and an emphasis on fun, both of which are still radio novelties in this region.

Classic Hits 98 FM came to Eastern Europe from Dublin looking for investment opportunities two years ago when it was unable to obtain a second broadcasting license in Ireland. In 1992, along with Czech partners, it obtained a license to start KISS 98 FM and was the last of 18 stations to go on the air in Prague during a rush of private license awards following the collapse of communism in 1989.

More fun, music, contests

"Everybody told us that we were too late and that there was no reason to come in as the last people," said KISS Promotional Manager Elaine Quinn, one of a team of three Irish managers and one Australian programming director leading the station. "But we did our research. We learned people wanted much more fun, music and contests on the radio."

The research proved on target. Since going in air, the 1 kW station has gained

124,000 listeners or, according to Quinn, about 17 percent of the metropolitan Prague audience it serves.

With a format of back-to-back, on-air



KISS 98's fleet of patrols

contests, plus selector-formatted, pop-music programming, it consistently ranks as one of the top three winners in the city's fierce radio competition for listeners.

"We try to reward our listeners all the time," Quinn said. "We have far more competitions and prizes than any other station in Prague."

'Classic Hits' as in Dublin, but our respondents said they thought it meant we would be playing Mozart," Quinn said. Instead, the station settled on KISS, which has no meaning in Czech but has a fast, pronounceable, Western image and sound.

"We've continued to research everything from music playlists to what prizes people want to win in our contest," Quinn said. The station uses its own tele-research staff three nights a week to judge listener response to competitions, DJs and music, she noted. Additionally, it routinely gathers several hundred listeners in an auditorium to test as many as 200 new songs and identify local hits before the music is aired.

On your own

KISS must do almost all of its research itself because reliable media research services are still often unavailable in Eastern European markets. "Getting independent market research is one of the biggest problems all forms of media and ad agencies have," Quinn said. She adds that research services in Prague often use sample sizes of just a few hundred people.

To date, the most popular contests on KISS have proved to be those already successful in mainstream Western European and American markets, with some exceptions. The station's longest-running, now hallmark, contest is its cash calls to private homes with jackpots averaging \$170. Also highly popular are hide-and-seek competitions with clues to

continued on page 80 ►

HERE'S WHAT A DIGITAL AUDIO DELIVERY SYSTEM CAN DO FOR YOU!

CHECK ALL THE FEATURES REQUIRED THEN CALL YOUR DAD486x DEALER

- | | | | | | |
|--------------------------|--------------------------|---|--------------------------|--------------------------|---|
| <input type="checkbox"/> | <input type="checkbox"/> | Powerful Live Assist Touchscreen flexibility, unlimited Automation capabilities, as well as interface to any Satellite Programming service, and the ability to seamlessly switch between them at any time. | <input type="checkbox"/> | <input type="checkbox"/> | Multiple Inputs & Outputs, both Analog & Digital . |
| <input type="checkbox"/> | <input type="checkbox"/> | "Racks Full" of Recorders and Reproducers , as well as huge Cart Walls with immediate random access to any Cut . | <input type="checkbox"/> | <input type="checkbox"/> | Intersperse Mono & Stereo Cuts without operator intervention. Simulcast with independent Spot & ID loads. |
| <input type="checkbox"/> | <input type="checkbox"/> | Sound "Live" in any mode, with layers of programmable Fades , Segues , and Voice Overs . | <input type="checkbox"/> | <input type="checkbox"/> | Interface with other common studio equipment such as Consoles, Switchers, CD Players, DAT's, Tape Machines, etc. |
| <input type="checkbox"/> | <input type="checkbox"/> | Display Script , Copy , or News Text for paperless operations. | <input type="checkbox"/> | <input type="checkbox"/> | A comprehensive Security System , limiting access to sensitive operations on a per User basis. |
| <input type="checkbox"/> | <input type="checkbox"/> | Automatically control multiple Network Joins and Breaks, as well as Time Shift any elements. | <input type="checkbox"/> | <input type="checkbox"/> | Operate on common Off The Shelf Hardware that can be purchased and maintained via local sources, requires no special training, and can easily be upgraded as computer technology continues to advance. |
| <input type="checkbox"/> | <input type="checkbox"/> | Advanced Production features such as Cut & Paste Editing , and Montage Assembly . Interchange digital files with many Multitrack Editing systems. | <input type="checkbox"/> | <input type="checkbox"/> | Configurable with Backup and Redundancy features for fail safe operation and data protection. |
| <input type="checkbox"/> | <input type="checkbox"/> | Interface with all common Scheduling and Billing systems, or be able to roll your own. | <input type="checkbox"/> | <input type="checkbox"/> | Offer the same Power and Flexibility whether configured as a small stand alone Workstation or expanded to a large multi-user networked system. |
| <input type="checkbox"/> | <input type="checkbox"/> | Each User can optimize, store, and immediately recall their own preferred layout and functionality. | <input type="checkbox"/> | <input type="checkbox"/> | So Simple and Intuitive to use that the Learning Curve for most operators is measured in Minutes . |

ONLY THE ENCO DAD486x DOES IT ALL
COST EFFECTIVELY - NO LICENSING FEES

For more information call 800-ENCO-SYS or 810-476-5711

Fax: 810-476-5712

ENCO
SYSTEMS, INC.

ENCO Systems, Inc.
24403 Halsted Road
Farmington Hills, MI 48335 USA

We Have What You Need!



COMPACT DISC PRODUCTION MUSIC AND SOUND EFFECTS LIBRARIES

Call, write or send us a fax and it will be a pleasure for us to send you a complete catalog of our compact disc libraries free of charge. Our catalogs have a large variety of what you need for your productions. For your convenience, we will be pleased to send you a demonstration compact disc containing all the information you need to place your order. But we can't send you our catalog until you get in touch with us.

Take the first step
and contact us today!

Valentino

... a complete library of production music and sound effects in an exclusive binder system.

Valentino

... Our products are used for productions around the world.

Valentino, inc

500 Executive Blvd., P.O. Box 534, Elmsford, NY 10523 USA
TEL: +1-914-347-7878 FAX: +1-914-347-4764

UPLINK

Studio Primer for Satellite Radio

by Karl Baehr

ALBUQUERQUE, N.M. Whereas it is true that with a little operational finesse many listeners won't know you're satellite, it is also true that with the initiation of a satellite format local production quality becomes more important than ever. With this in mind, let's take a look at some things you can do right now to improve your production process.

Improvement list

Have you—engineer give the room a once-over from top to bottom and assess the production facility. What is needed from a technical/engineering standpoint? Once you have a reference point for the room, set a regular maintenance schedule so that all aspects of the room are maintained.

Have your engineer produce a set of guidelines for the production staff to follow while using the room. This may help cut down time due to minor problems that could have been prevented with a little common sense.

Local production quality is important for satellite formats.

Ask your production director for two lists. One list assessing the room itself operationally, and the production process as well. The second, a wish list of what is needed, what needs to be replaced, etc.

Invite the sales manager and sales staff, program director and programming staff to comment on the current production process at the station. Problems they have experienced personally as well as things that have worked well. Ask them for suggestions to correct each problem/difficulty.

Sit down with your traffic manager and review the process from their point of view. It is very important to get all this feedback from the different perspectives at your station because production is perhaps the one thing that directly impacts them all every day.

Once you have gathered all this information from the various sources, sit down and review it thoughtfully. Make lists of good and bad points from each perspective. You may start to see common denominators in each; these are your priorities. If they are common problems, rectify them now. If they are common positives, let all involved know that "we are all in agreement on these items."

Once a decision is made regarding where you go from here...post the results in a memo to all station personnel. As they all had input, it is a good thing to see the results of their efforts and that those efforts are considered. You don't want your people thinking that their input is meaningless "so why bother."

Facility ideas

Regarding the facility itself, I have a few suggestions:

- Multitrack units are cost effective enough these days. If you do not have at least four-track capability, you should consider an upgrade.
- There are a great many effects boxes. If you don't have a good "utility" effects unit that gives you basic voice effects such as phasing, flange, sampling, echo,

etc., think about getting one. Have your production director "ride shotgun" on this unit for a while as every spot produced will have some effect in it until people get used to using the new toy.

- If you have some type of general compressor/limiter unit, make sure that each person doing production has his or her own settings. This will take some work, but the end result will cut down on muddy production, boomy bass and that feeling of coliseum reverb when personality B sits down and does a spot with personality A's settings.

- Consider DAT if you don't already have

it. For archiving, it's great as you maintain a digital quality and cut down on your space requirements for storage dramatically.

- If you don't have a good, contemporary production music and sound effects library, get one. There are many choices from expensive to not so expensive. Believe me, your audience is getting tired of your ripping off those sound track instrumental cuts.

Studio ideas

Concerning the production process, here are a few suggestions:

- Standardize cart labeling. All cart labels should be neatly typed and contain the name of the produced element, start and end dates, exact time, producer's initials and cue. Use different colored labels for station elements such as promos and drops to separate them visually from commercial elements. Different colors for 30- and 60-second elements is a good idea too.

- Set up a common area for filing production copy when it has been completed. Have the producer initial the copy and put the date it was produced. There should also be a notation of which production music/elements were used.

- A production log should be maintained in and not leave the production room. This should contain the name of the produced

continued on page 74 ▶

**YOU CAN SHARE PROGRAMMING
AMONG YOUR RADIO STATIONS ...
At a Lower Cost Than Ever Before!**

Share programming among your station group or with other stations by sharing day parts, entire formats or by delivering your top-rated talent to other markets coast to coast. You can spread overhead costs, increase the quality of programming at the local station and build your audience by creating a satellite radio network. And now new digital satellite technology makes radio networking more affordable than ever before. Let us offer you a complete solution for your radio networking needs.

Call us at (202) 414-2626

NPR SATELLITE SERVICES®
Has moved to:
635 Massachusetts Ave., NW, Washington, DC 20001-3753
(202) 414-2626

Circle (53) On Reader Service Card

New Formats Look to Past Successes

► continued from page 65

now as likely to be dancing to Thin White Duke-era David Bowie or Duran Duran as they are to Crystal Waters or Janet Jackson.

What is driving the new '80s nostalgia wave for Generation Xers is no different than the driving force for '70s nostalgia among the 30-40 crowd: high school and college memories.

These young men and women are now out on their own, setting up apartments, buying first new cars, establishing themselves in the professional work force. They represent a huge, potentially lucrative market for radio stations. Right now, the only place these folks can get their fix of '80s music is in the clubs. It does not have to be that way.

Some forward-thinking programmers are already predicting '80s nostalgia radio formats. Both David Rahn of SBR Radio and Alan Smith of Active Industry Research have gone on

record in previous RW articles, predicting "classic modern rock" as an inevitable segmentation of the alternative rock format.

This library-based idea is only now becoming a format possibility, primarily because there was no library of modern rock hits before the '80s. Now, 15 or more years later, many bands which would not have had a prayer of being played on AOR stations in the 3 a.m. to 6 a.m. time slot during the 1970s are bona fide musical celebrities.

So, if you want to be really cutting edge, pull out your old Devo records, and trade your bell bottoms for a narrow tie and spike hairdo. Your best friend's annoying kid brother may now be your company accountant, and he wants to hear something that reminds him of wasted nights doing the Pogo at the Theta Delta Chi smoker with a Kappa Alpha Theta sorority pledge—who is now your legal counsel.

How Good Is Your Studio Product?

► continued from page 73

element, producer, date produced and archived location.

• All production should be assigned by and through the production director. If a specific talent is requested then that should be noted on the production request/copy form.

Copywriting

Regarding copywriting, it would not be a bad idea to contact the NAB and check out a few of their books on the subject. There are several copywriting books available that look at effective copywriting from the agency perspective as well. As you may know, I am a big fan of a station resource library. We have talked in the past about programming and sales resources libraries; production should not be overlooked. Make these materials readily available to everyone connected with the production process. The sharper the edge you keep on your staff, the sharper your edge on the air. A side note here, just because they can naturally sell the avails right off of your station does not mean that they are naturally great copywriters. Concepts translate into reality from the copy. Give your people the tools they need to do the job right.

Don't be afraid to experiment with copy. What keeps this process fun for me is that I always stretch a bit. Sometimes it works, sometimes it doesn't. Don't reduce you producers to talking heads. Let them run with the copy a bit. By giving an individual a little rope, you'd be amazed at how far some will run.

If your production is noticeably different in quality from either an audio or talent standpoint, it's time for an upgrade. The trick here is to play your locally produced spots right up with the network spots and notice little difference in quality. A good clean spot is the goal.

Tap the network

Don't forget your network. The talent is available for commercial work at competitive rates, and this continuity on the air is great. Send airchecks of your local production to your network for feedback.

A closing comment about selling your station's product. There is one in every market, one station that seems to have its personalities show up on various spots around town. It could be your station. The production value of your station is directly related to the quality of the product you put on the air. Polish it up a bit, put a demo tape together and circulate it to the agencies in town, the TV station, cable outlet and chamber of commerce.

Let your community know that you do good work for your clients and can help them sound their best. Nothing keeps a client happy and coming back for more than a commercial that worked.

□ □ □

Karl Baehr is president of KBE "Broadcasting By Design," a radio consulting firm providing support services for satellite radio stations and produces the Actual Radio Measurement (ARM) electronic survey system. He can be reached at 505-828-0488; or fax: 505-821-4226.

RE digital audio encoder and decoder

RE audio codecs — full compliance with the industry standard

Buy an audio codec from just about anybody other than RE and you may get more than you bargained for—hopeless operational procedures, non-standard compression protocols and limited connectivity.

Then again, you may get less. Less bandwidth. Fewer compression options. No service.

Let's face it. There are a lot of products out there that promise you the world, yet corrupt your signal and complicate your life. You simply cannot afford non-standard audio codecs. That's why when the time comes to look at your audio transmission needs, you'll want to take a closer look at RE.

RE offers ISO/MPEG Layer II audio compression, which is the most widely used high-fidelity audio compression algorithm in the industry. We're the only company in the world that can offer you half sampling frequencies for a choice of six different sampling rates, and bandwidths up to a full 20kHz. We're also the company to provide CRC scale factors to protect your

audio from transmission errors. And when it comes to compression and compatibility, our implementation of ISO/MPEG Layer II has been thoroughly checked and tested by the IRT in Munich—part of the very team that invented the standard in the first place.

With several outstanding RE *Easy ISDN* packages to choose from, why not give us a call? For further information, contact RE at (216) 871-7617

-
-
-
-
-
-
-
-
-
-

re

Running Radio

A Supermarket of Radio Station Services

For information on the services shown below, circle the Reader Service number on the enclosed card or contact the advertiser directly.

ESCAPE TO THE OUTDOORS

WINNER OF 40+ BROADCAST AWARDS!

- BRING THE GREAT OUTDOORS TO YOUR LISTENERS AND ADVERTISERS WITH OUR DAILY 4-MINUTE PROGRAM.
- ADD A NATIONAL PROGRAM TO YOUR LINE-UP FOR FREE AND ENJOY IN-MARKET EXCLUSIVITY.
- SINCE 1986, WE HAVE TRAVELED THE COUNTRY COVERING OUTDOOR TOPICS THAT LISTENERS WANT TO HEAR, INCLUDING CAMPING, HOW-TO TIPS, COOKING, FISHING, THE ENVIRONMENT, CELEBRITY INTERVIEWS AND MORE, 312 NEW SHOWS A YEAR!
- CALL (800) 248-9687 FOR A FREE DEMO TAPE OR TO SIGN UP NOW.

"An excellent program that speaks to the outdoor enthusiast. Great tips, insightful and extremely informative. We like it!"

— Ken Byers, Operations Manager
KCKY-AM 1150, Coolidge, AZ. (Phoenix market)

Reader Service No. 38

mark INDY CAR Radio Network

Radio's Fastest Network...

IndyCar racing is hotter than ever.

The Teams
The Cars
The Championship

To find out how your station can be a part of the excitement-
Call Ruth at (317) 846-5004

Presented by PPC, The KMart IndyCar Radio Network is produced by Page Productions

Reader Service No. 195

NASHVILLE Record Review CROOK & CHASE

COUNTS DOWN COUNTRY'S TOP 40

THE NASHVILLE RECORD REVIEW, HOSTED BY LORIANNE CROOK AND CHARLIE CHASE OF TNN'S MUSIC CITY TONIGHT, IS ONE OF RADIO'S FASTEST GROWING COUNTRY COUNTDOWN SHOWS.

A FOUR-HOUR WEEKLY SYNDICATED RADIO PROGRAM PRODUCED ON COMPACT DISC.

FOR MORE INFORMATION CONTACT

EAST: FRANK IACONA,
(203) 965-6217
WEST: CRAIG CHAMBERS,
(303) 771-9800

Reader Service No. 63

Good Times - Great Oldies! Celebrity Guests...



The Beatles
Bobby Vinton
The Lovin' Spoonful
The Supremes
Herman's Hermits
James Brown
The Grassroots
Lesley Gore
Johnny Rivers
Elvis
...And Others

Here's Your Chance To "Make The Grade"!

For A Demo Of This Weekly, 4-Hour Show:

1-800-985-2665

Distributed by COPRA Media Productions, Inc.
444 Westgrove Drive, Suite 210, Dallas, TX 75248

Reader Service No. 44

Radio World

Vol. 18, No. 16 Radio's Best Read Newspaper August 10, 1994

Attention Advertisers!

Reach 22,000+ broadcast professionals! Radio World's Product Showcase provides a perfect medium for test marketing your products and services. It's an efficient, effective and affordable advertising option.

Product Showcase ads always get impressive results!

Advertise in the Product Showcase Directory!

"It Works! It's Great!"

For more information, including rates and deadlines,
Fax Simone at
1-703-998-2966
or call
1-800-336-3045

Advertising is good for business!

We Syndicate Radio Programming Around the Country & Around the World

Sales
Clearing
Uplinking
Short Form &
Long Form Programming



800-SRN-RADIO
fax **314-423-4014**

Reader Service No. 166

CHANGING FORMATS AGAIN? THIS TIME DO IT RIGHT! TURN ON the LYTE!

Refreshing, Sophisticated NAC & Smooth Jazz hits Localized & digitally satellite delivered 24 hrs/day. The Fresh, New FRANCHISE FORMAT that will position your station in front of all of the others on the crowded radio dial. Intelligent New Adult Contemporary sounds that Captivate and Deliver the up-scale professional audience of consumers that advertisers find difficult to reach.

REDUCE EXPENSES & INCREASE PROFITS WITH theLYTE'S WINNING NAC SMOOTH JAZZ SOUND
ACT NOW! CALL 1-800-843-5983

1-800-theLYTE

YOUR FIRST CHOICE FOR YOUR LAST FORMAT
TARGET RADIO SATELLITE NETWORKS, INC.

Reader Service No. 87

GET THE BEST MUSIC, THE BEST QUALITY, THE BEST PRICE!

WE'VE GOT IT ALL
Oldies HOT AC
Seventies CHR
AC Country

ALL ready to make your format *sizzle* this summer! ALL in stock...
ALL at terrific prices!

To Get It ALL on CD Just Call Our Name!

1-800-HALLAND



SEE US AT WME BOOTH # 1828

Halland Broadcast Services, Inc.
1289 E. Alosta Avenue • Glendora, CA 91740
tel: (818) 963-6300 • fax: (818) 963-2070

Reader Service No. 213



Expose yourself with a minimum of risk.

Today's level of fierce competition demands that you prominently display your name every chance you get. Theft, vandalism and loss are an expensive reality.

high quality 4 or 6 mil plastic film display your logo and message brilliantly. Now you can afford to display a bright new sign at every public event. They even make great cost-effective promotional giveaways. Just roll off what you need and cut.

Roll-A-Sign™ offers a better way. Up to four vibrant colors printed on durable,

Call today and get exposed.

800/231-2417

Reef Industries, Inc. • P.O. Box 750245 • Houston, TX 77275-0245
713/484-6892 • 713/947-2053 FAX

©1994 Reef Industries, Inc.
Reader Service No. 88

M A R K E T P L A C E

TECH-TALK

Cincinnati Boasts DAB AM Station

by Judith Gross

NEW YORK We all know about the Electronic Industries Association's (EIA) tests of DAB—or DAR, as they like to call it. But other than that, current wisdom is that DAB is not happening; that there is nothing new to report; that the lack of splash and dazzle means it's a dead issue.

Well, like Mark Twain's, the death knell on DAB is, to say the least, greatly exaggerated.

The last few months, at least as far as USA Digital, the in-band, on-channel (IBOC) system that is a collaboration between Group W, CBS Radio and Gannett Broadcasting, have been anything but quiet on the DAB front. Two fronts, to be exact: Chicago for the FM and AM systems (as reported in recent issues of *RW*) and Cincinnati for the AM system.

Both tests have shown that USA Digital is alive and well and moving towards a real-world development which proceeds no matter what is happening in the EIA's lab in Cleveland.

AM in Cincinnati

The AM is being tested by Group W, on an experimental station at 1660 kHz in Cincinnati. The system is authorized to broadcast up to 10 kW but so far has not gone that high, mostly because antenna modifications are needed.

The big news is that the USA Digital AM signal is operating through a Harris DX 10 digitally modulated transmitter that has been only slightly modified. The tests are being done through a cooperative effort between USA Digital and Xetron, the company that developed the AM system.

"When the Xetron folks said they could put it through an existing transmitter, I wasn't sure," said Glynn Walden, Engineering Manager for Group W stations, the

USA Digital participant in charge of AM DAB. "They fed it into the Harris DX 10 with only minor modifications, tested it with a dummy load and it worked the first time around, with music," he added.

Harris AM Product Manager John

The USA Digital AM signal is operating through a Harris DX 10 transmitter.

Delay notes that the changes to the DX 10 were minimal. "It's a standard, off-the-shelf model with several minor modifications that could be done easily in the field. The changes were only to increase the frequency response of the transmitter and adjust levels."

The USA Digital AM system has evolved into a quadrature system. This means it is not compatible with the Motorola C-QUAM AM stereo system for analog, so stations broadcasting a USA Digital signal would be stereo on the digital signal but not on their analog signal. Generally, only slightly above 15 percent of all existing AM stations have made the switch to stereo.

Tweaking the system

Since the last convention where the AM system was demonstrated, USA Digital and Xetron have tweaked the system to ensure that it works in a mobile environment.

"There have been significant changes in error correction; we applied some techniques we developed for DAB FM. There have also been some MUSICAM upgrades from Corporate Computer Systems," Walden noted. "we've also made some receiver improvements."

The system has been transmitted over a limited antenna setup, the Kintronic Desert Storm antenna, which is really only a "backup" antenna.

The current setup only allows about 10-15 percent efficiency for 100 W on the analog signal and 15 W on the digital. This translates to about 15 W of power for the analog and around 1.5 kW for the digital, but even at these low powers, Walden said the DAB system has performed well.

"At only 1.5 kW it [the signal] went out eight miles and survived six of eight overpasses, which is better than some full power AM stations do now," Walden said. "Of course, the Xetron people are eager to make it survive all eight overpasses."

That will be the order of the day once USA Digital gets the proper antenna setup and is able to go to 10 kW. Immediate plans are to modify the Desert



Storm antenna to accommodate the increased power.

"Tom King at Kintronics is shipping us a new tuning box for it and we'll retune the antenna and test it some more," said Walden. "After we test it on the experi-

mental station we'll test it on one of our existing stations to see how it performs at full power in a real-world situation."

The USA Digital AM system will also be demonstrated at the World Media Expo next month, at the Harris Allied booth, operating through a DX 10 transmitter.

"We'll be doing live demonstrations of the USA Digital AM and an analog AM signal both through the DX 10, so managers and engineers can do an A-B comparison," noted Delay. "The message will be that customers deciding about a transmitter today can make a fairly safe bet in purchasing a Harris DX because it's surely going to be compatible with DAB."

FM in Chicago

Things have been anything but quiet for USA Digital FM as well. Tony Masiello, VP of Engineering for CBS Radio, has been spending a lot of time in Chicago, testing the USA Digital DAB FM system over real-world broadcasts on WBBM-FM.

"It's been on at all different hours, not just late at night for our tests," Masiello said. "It performs well; multipath in and of itself is not a problem. We're trying to investigate the dynamics of real world broadcasting, like going under three overpasses in a row at 60 mph."

Masiello reported that the FM DAB has been tested for interference to the analog signal as well as to WBBM-FM's two subcarriers at 57 kHz and 92 kHz.

"We haven't received any indication that this has caused any disruption in the services which use these subcarriers," said Masiello.

The FM system on the air in Chicago is USA Digital FM1, one of two systems submitted for testing in the EIA tests. But Masiello explained that to test performance in a mobile environment, the FM1 system in Chicago has been modified and updated.

"The digital modem is exactly identical, and the CCS MUSICAM implementation. But the front end is different because we've adapted it for mobile reception. The AGC is more sensitive; the front end submitted for lab tests would not work in mobile environment at all," he said.

The system has undergone some improvements, including the interleaver link and type of error correction profile employed. One non-technical development is that the technological components of the USA FM system have gone to the patent office, which means that the system can be described by its proponents publicly and in more detail.

That will most likely happen at the World Media Expo in October, where the FM system will be demonstrated, much as it has been in the past, at the USA Digital booth.

No busses; no fancy rides...just some solid behind the scenes progress.

□ □ □

Judith Gross runs her own writing/public relations company, JG Communications, and can be reached at 718-392-3288.

Need To Know How To Sell More Advertising?

The Griffin Reports is a proven sales tool that provides qualitative research tailored for your geographic market. Our research provides local listener demographics plus information about how much they spend, what they buy and where and how often they shop. It's highly targeted, flexible and affordable.

If you want to sell more to current accounts, or if you need help convincing new clients that your station should be on their buys, call Griffin. We know how to help with the audience information that can give your station a competitive edge.

Griffin Knows.



Sales Office: 5910 Mt. Moriah Suite 113-257 Memphis, TN 38115 1-800-723-4743

PROMO POWER

Good, Scary Fun Is Key to Fall Promos

*Radio Stations Can Shine with the Community and with Their Fans
By Partying Hard for Halloween and for Good Causes in Their Area*

by Mark Lapidus

WASHINGTON Three guys came in. Each had a door attached to his back. They told me they were "The Doors." A woman wearing a huge heart attached to a chain was being pulled around the room by her date. They came as Stevie Nicks' song "Stop Dragging My Heart Around." A short man wearing battery cables around his head said he was AC-DC.

I had the pleasure of meeting all of these characters many years ago at an annual rock 'n' roll costume party tied in with my current radio station. Although I'd thought of it before, it really hit me that night: radio is at its zenith when it becomes a visual medium.

The mind's eye

Think about it. This happens whenever your station broadcasts a compelling piece of audio. A great song can do it. A great DJ can do it. A great promotion can do it too.

When you create a killer promotion, the idea will make your listeners smile when they hear about it. They may even talk about your station to their friends. If you have not done it recently, your chance to paint the picture is right around the corner because the most visual holiday of the year is nearly here. Are you ready for Halloween?

Make your first decision regarding Halloween based on your target audience. Are you reaching 18-34 year old rockers who will want to party? Should you devise an event for the kids of your 30-40+ year-old parents? Could you create a program or event for the 40-50 year

olds who want to feel a little younger for the night? Consider these questions as you parade through the chestnuts listed below.

Party sampler:

—Rock 'N' Roll Halloween Costume Party. As you read above, simply invite your listeners to dress up as their favorite rock star, album cover, song title or any-

When you create a killer promotion, the idea will make your listeners smile when they hear about it.

thing related to your radio station like a jock or a special feature. Award prizes for best costumes. A week prior, have your talent give examples on-air, tying in artists and song titles they have just played.

If you are really ambitious, you can do this at several clubs at once. Rent a bus for the entire airstaff. Have them spend an hour in each place. Make sure to get them costume trade so they are dressed to thrill. This could be done as a country party as well.

—The dead do a concert. I don't mean the Grateful Dead. Promote it as a night of the living dead. Begin by holding a seance on stage, bringing each featured act back to life. Hire cover bands and impersonators to actually perform full sets of each person's music. Elvis is a great one... bring the king out of a coffin.

—The W— Haunted House. Find the Jaycees in your market that already do one and make it bigger by promoting it. Usually the Jaycees do a great job with

these... they just don't get enough publicity. Have jocks host nights. Do live broadcasts. Hand out station goody bags. Do discount coupons at a retailer.

Community spirit

—The W— X-Ray Examiner. Find (sell?) a hospital on putting its X-Ray machines to use on children's candy. Nobody likes candy with metal in it. Work the press way in advance on this. You may even be able to get a newspaper or television partner to co-promote it with you.

—Host a scary movie on television. Go to your local independent television station and see if it would like the most talented (and good-looking) jock on your staff to dress up and host a classic spooky film. Tape his or her part in advance from the haunted house your station is now promoting. Promote it on radio and television. Sell schedules on radio and television to one sponsor.

—Trick or treat in a mall. Many cities have gotten too spooky with criminals. If your demographic has young kids, provide an alternative by having a special "trick or treat" session worked out with each merchant in the mall. The station provides the publicity, the goody bag with station logo and a few grand prizes for the parents. This one is easily sold. If possible, tie in a national candy client so you can give away free candy.

—Wash the dead. Create the first drive-through haunted house in your market. Get a local car wash to decorate the inside (make sure it is waterproof).

—Pumpkin bowling/pumpkin drop/pumpkin eating contests. These work

great in bars or tall buildings or both. The pumpkin eating works especially well with celebrity or jock "eat-offs."

—Bury the past. Hey... there is no time like the present for a time capsule. Spend a few days on the air letting your listeners tell you what should be included. Stage a media event with a local celebrity (mayor?) breaking ground.

—Bury a jock. I have done this before and I can attest to the fact that it is extremely dangerous. It also generates a lot of talk. You need: 1) A coffin 2) A backhoe 3) Tubing to run out to the air and oxygen just in case 4) Great release forms and attorneys standing by. *Note: This really is one of the most dangerous Halloween stunts around.*

—Halloween Murder Mystery Train. There already may be one in your city. If there is not, see if you can get a theater group interested in doing a huge party train to a nearby city for Halloween Night. They act out a murder. Your listeners wear silly costumes and drink heavily. The general sales manager gets a schedule from a beer sponsor. Everybody is happy.

—Blood drive. You can count on the Red Cross folks to want more blood. If you make the area scary enough, you may actually get television coverage.

Halloween night, make sure you are airing the most frightening songs your format can offer. If you are doing a promotion, be sure to broadcast from a location. See if you can get a local politician or car dealer to co-host... You gotta admit, that's pretty scary.

□□□

Mark Lapidus is director of marketing for Liberty Broadcasting. Liberty owns WXTR-FM and WHFS(FM) in the Washington market; WGBB(AM)-WBAB-FM on Long Island, N.Y.; WGNA-AM-FM Albany, N.Y., and WMXB(FM) in Richmond, Va. Mark can be reached at 301-899-3014; or write him care of RW.



Depend On Us.



Rock Solid. Just like our friends on the right, we've been around for years. 25 years under the same ownership. At RPM quality and service come first. Right now over 2,000 clients worldwide depend on us.

If you need a CD music library, CD weekly hits or full format service, you can depend on us. We have the music and format you need at a 90's price.

CD Music Library: 1100 tracks \$2495.00
CD Top Hits USA: \$16.95/wk \$49.95/mo
Format Services: from \$295.00/month



800-521-2537

Fax: 810-681-3936

Over 2000 clients Worldwide!

Top Hits U.S.A. and Ultrasonic-Q Radio Disc are trademarks of Radio Programming and Management, Inc., 4198 Orchard Lake Road, Orchard Lake, Michigan 48323. The Ultrasonic-Q system is Patented.

Circle (142) On Reader Service Card

STATION SERVICES

News and Services for Business, Programming and Sales

Sports-Talk Programming and More

MARYLAND HEIGHTS, Mo. The SRN Radio Network offers more than 20 hours per week of syndicated programming. Its first show, "Sports Memories," began in 1989.

In addition to Sports Memories, SRN offers "Sports American Update," a sports program akin to the "Sports Center" TV Show. It provides audio highlights from games and sports talk.

SRN also offers short-form programs, talk shows and musical formats, and intends to grow into a 24-hour, 7-days-per-week program supplier.

For information, contact Michael G. Talir in Missouri at 314-781-5404; fax: 314-423-4014; or circle **Reader Service 110**.

New Country and Christian Offerings

DALLAS Right-Turn Radio offers a new Sunday morning syndicated program "Face To Face." Face To Face is a two-hour Christian music program programmed for mainstream audiences preparing for church.

For information, contact Terry Wright in Texas at 214-471-0249; fax: 214-393-2526; or circle **Reader Service 31**.

Football Games to Appease Baseball Fans

NEW YORK CBS Radio offers sports fans suffering through the baseball strike some condolences in the form of NFL football. Through a special arrangement with the NFL, CBS Radio will broadcast several Sunday and Thursday night football games in October.

If the strike is settled and the baseball season resumes, CBS Radio will discontinue the Sunday night football games in favor of baseball games. The Thursday night football games will be run regardless.

For information, contact Helene Blieberg in New York at 212-975-371; or circle **Reader Service 101**.

CD/CD-ROM disc from Music Bakery

DALLAS The Music Bakery offers its 17th CD, which is playable on both standard CD and CD-ROM players. The CD

features live music by real musicians in full-length (four to six minute) versions as well as 60 and 30 second selection and tags.

Each Music Bakery CD is available for the buy-out price of \$48, and a catalog describing all previous CDs is available.

For information, contact Jack Waldenmaier in Texas at 800-229-0313; fax: 214-414-3160; or circle **Reader Service 40**.

Sales Software Package

KNOXVILLE, Tenn. Murb Communications offers a software package for radio station sales departments. EasyGrid Version 2.03 is available in formats for single stations, combos and duopolies.

The program allows sales managers to develop up to 32 different demand-driven rate cards for each station or a combination of stations. The sales staff can then generate custom proposals for advertising clients.

For information, contact Mike Beverly in Tennessee at 615-675-4637; or circle **Reader Service 17**.

Program to Promote Better Living

PUTNAM VALLEY, Calif. "The Living Springs Report," a two-minute

program designed to help people feel better and be healthier makes its debut October 3.

Written and narrated by David DeRose, M.D., M.P.H., the program is available on a market-exclusive basis. It also will feature specific questions from potential affiliates and live or prerecorded phone calls from affiliates or their listeners.

For information, contact "The Living Springs Report" Affiliate Relations Department at 203-288-0644; or circle **Reader Service 85**.

Pet Talk Radio Show

COLORADO SPRINGS, Colo. The Business Radio Network offers "Let's Talk Pets," a two-hour, live, interactive radio program about pet owners, companion animals and veterinary medicine. It features call-ins from listeners nationwide, news stories about pets, animal health issues and tips and special guests.

Airing live on Saturday afternoons with a rebroadcast the following Sunday morning, the show helps pet owners keep their animals healthy, plus save money, time and worry.

For information, contact Business Radio Network in Colorado at 719-528-7040; fax: 719-528-1438; or circle **Reader Service 61**.

Before SMARTS Broadcast Systems...



Music and spots were played on unreliable analog equipment.



Then came the **SMARTS AGE!** Music and spots were now broadcast in full digital audio!



But station operators still wondered...

"What do I do with my old, archaic analog equipment?"

Finally, the answer came...



For a limited time, SMARTS Broadcast Systems will buy back your old analog cart machine with the purchase of a SMARTCASTER Digital Audio System, including

- Digital Cart Machine Replacement
- Satellite Automation
- CD Automation
- Music-On-Hard-Drive Automation
- Generation 2000 Digital Audio Computer Network

Call SMARTS Broadcast Systems for details.

(800) 747-6278

SMARTS
Broadcast Systems

We're changing the world of broadcasting!

Circle (136) On Reader Service Card

STATION/STUDIO SERVICES

427 SOUND EFFECTS
\$89.00

For a 5-CD set with a 30-day money-back guarantee.

Take an extra \$10 off if you mention this ad!

Send \$79 to Ghostwriters
2412 Unity Ave. N., Dept. RW
Minneapolis, MN 55422

For credit card orders call
(612) 522-6256

READER SERVICE 58

Custom Radio Jingles!
Retail Client Jingles!

Complete Packages Start At

\$795



1-305-743-4248

READER SERVICE 188

Station Services are a great, economical way to get your company's message to Radio Station and Recording Studio owners/managers and engineers. Call Simone now and your ad could be in the next issue of Radio World.

BUY-OUT MUSIC — \$99

Sixty 60-second music beds for .. \$99
198 :30 & :60 music beds for ... \$198
2200 Hanna-Barbera (C)
Sound Effects for \$495
110 Lasers & Sweepers for \$99

For FREE DETAILS on production music, sound effects, call

Ghostwriters (612) 522-6256

READER SERVICE 58

ATTENTION PROVIDERS!

Promote your services to **Radio World's** 22,000+ readers. Reach Radio Station and Recording Studio owners/managers and engineers with your message. For information on affordable advertising call **Simone** at **1-800-336-3045**.

OFFBEAT RADIO

Ratings Measured from Cars

by Dee McVicker

PHOENIX A new electronic ratings system is putting a new spin on drive time listenership in Phoenix, Ariz.

Commuters in this market don't know it, but they're part of a pilot test conducted by Trendata Corporation that electronically samples over two million in-car radios every month. Concealed roadside computers lock onto, record and tabulate the FM signals playing from one out of every eight cars passing by.

"We put together a computer program which acts kind of like a Bearcat scanner," explained Earl Baldwin, the marketing director of Trendata of Mesa, Ariz. "As all the cars go by, it rotates the FM signals with 10.7 MHz added onto it. When it locks onto a signal, it records it, the station, frequency, time and location. Then it releases it and searches for another."

A new method

Tallied up, these electronic snapshots measure not only the stations most listened to by mobile FM listeners, but during what time segments they're being listened to and in what geographic neighborhood.

As one veteran broadcaster in the market commented, the system is a far cry from the old days when program directors surveyed the market by peeking into cars at shopping malls to check where the radio dial was positioned.

Trendata is up and running in the market 24-hours a day, seven days a week. Every weekday, approximately 20 Trendata computers, disguised as mobile units, are found at various roadside locations around the Phoenix area to survey a cross section of the moving population. Each location is sampled for 48 hours, after which the computers are moved to a new location.

Surveying cars

About 4,000 to 6,000 cars are surveyed per location on a typical weekday, a collective sampling of over 100,000 listeners a day for all 20 locations. On weekends, Trendata monitors cars driving by shopping centers and entertainment events.

The system, which rates only FM listenership, has been beta testing in the Phoenix market for almost two years and is ready to head out into new markets soon. And soon, Trendata expects to have market information available in real-time to just about any program director with a computer and a modem.

"We are working on a third generation now that will be the size of cigar box and can attach to a telephone pole or on a telephone wire," Baldwin said. "We'll have 50 or 60 locations in a market and program directors will be able to sit in their offices and select any number of our locations in real-time. And they'll be able to tell, for example, while a song is playing what the competition is doing and if that song will hold an audience."

But although the future implications of the system are indeed bright, Baldwin maintains that the electronic ratings system probably will not replace tried-and-true Arbitron ratings methods.

For one thing, the nature of the technology excludes AM and stationary listenership. For another, it's not likely Trendata can capture the market to the same capacity as diaries and telesurveys.

"For getting demographics and doing in-depth, you got to use phones, you got to

use diaries. That's a system that does work," Baldwin said. But for monitoring up-to-the-minute market shifts, format changes, and personality changes, he said, it's hard to beat the immediacy of Trendata information gathering.

A major change in the Phoenix market recently proved Baldwin right. When Phoenix rocker KSLX-FM revamped its playlist and hired on new morning team John Giese and Bill Andres, Trendata in-vehicle listenership indicated that the station would experience a substantial increase in listenership in the next Arbitron period. It did. Two months later, when the spring

Arbitron hit, KSLX-FM made the top 10 with a 4.0, up 1.8 points with 12 plus listeners.

Detecting changes

"When a change does occur, we see it in the first couple of weeks, not months," Baldwin said. Immediacy is just one of the benefits of the system. Electronic ratings could put smaller stations, which have long been penalized for covering part, but not all, of

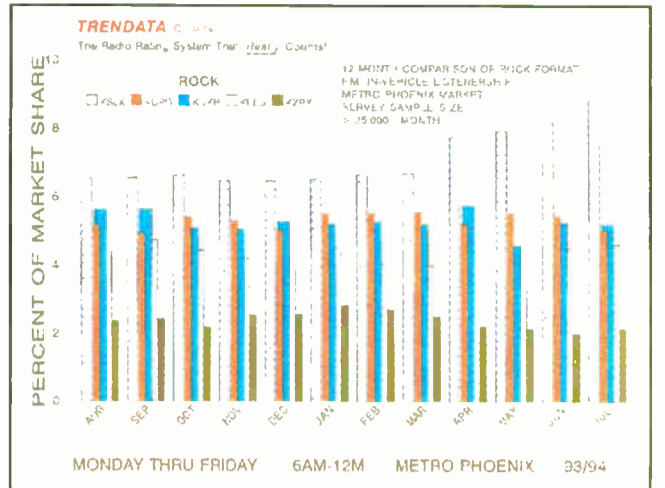

a metro area, on equal footing with market powerhouses, at least on continued on page 80

LOGITEK Audio Meters

Because You Can't Fix It If You Can't Find It!

Super-VU

- Three color LED bargraphs
- Simultaneous VU, PPM & peak hold
- Stereo phase and sum display
- 40 dB or 60 dB range
- .1 dB Accuracy
- Digital or Analog inputs
- Table top and rackmount versions

Bright-VU

- Color coded LED bargraphs
- 40 dB range
- Loudness or peak display
- Table top and rackmount versions
- Our most economic meter

4VUB

- Lighted VU meters
- Adjustable zero VU point
- Balanced bridging inputs

Logitek Electronic Systems, Inc.

When It Has To Work Right

800-231-5870 or 713-782-4592

Circle (140) On Reader Service Card

World Radio History

FM Takes to the Streets of Prague

► continued from page 72

a car or motorcycle hidden somewhere in the city.

The station's target audience—primarily 25 to 35 year olds with a secondary range of 20 to 45 year olds—is surprisingly responsive, too, to competitions built around public stunts, which today are less attention-getting in the West. A recent contest, which challenged a married couple to live two weeks in a department store window to win home furnishings, sparked interest not only locally but was reported on the evening news even as far away as Moscow.

"Every week we challenge our audience to do something mad, and we get a high response," Quinn said. "For example, 98 people will climb into a fountain at once." But, she cautioned, the station's Irish managers found they cannot always predict from their own experience what ideas will or will not work in their new market.

Quinn recalls one April Fool's Day contest suggestion from the station's own Czech employee to make on-the-air calls to homes to inform families that a relative had just died. "I had to reject that one," she said. Foreign managers equally have to check their proposals with the 31 Czech staff members at the station to stay on target.

All the contests and stunts at KISS

have caught the attention of advertisers as well as listeners. Many foreign and local companies that still need to build name recognition in the Prague market see the station's outreach activities as a means of both publicizing and offering free sample of their products directly to consumers.

Have a Malibu

One new product in the Czech market, a cocktail drink called Malibu, sponsors a KISS contest to win a visit from station representatives to listeners' weekend parties. This KISS staff members bring 'Malibu party packages' to introduce winners to the drink. But in the new world of applying such Western marketing practices to Eastern Europe, there is the danger of losing some impact in translation.

"A recent survey asked people in the street what 'Malibu' is, and most people responded that it is a kind of KISS contest," Quinn said.

The station has found advertiser tie-ins not only with its on-the-air contests but also for its fleet of six roving KISS patrol cars that give the station a daily street presence. "We are the only station in Prague doing street activity," Quinn said. The patrol routinely stops cars to offer gifts as well as visit public events, she said, but

Prague advertisers hire the teams to give out free sample of products for publicity.

Saving on technology

As KISS has maximized its investment in such audience- and advertiser-appealing outreach activities, the station has saved on its technical budget by utilizing basic equipment for all operations.

"We use all analog, standard Western equipment," said engineer Pavel Polak. Only our ad production is digital." He noted that the standard range of equipment delivers all the quality the station needs for its signature sound, which mixes high-energy DJ call outs with

mainstream to heavy rock.

At the same time, Polak said, KISS DJs have found they don't have time for more complex studio equipment. "We keep the operations as simple as possible so that they have both hands free for the telephone," he said. The daily playlist is all transferred first to cartridges, for rapid loading and firing by the DJs among their contest calls.

KISS is banking on its formula of more contests, music and fun to keep it ahead as Prague's radio market matures in the future. Currently, 22 private stations hold licenses to broadcast in the city, and advertising revenue is insufficient to insure all can operate profitably.

□ □ □

Charles Recknagel covers the industry for RW from Prague, Czech Republic.

Eavesdropping on Cars

► continued from page 79

their respective street corners.

Some advertisers, such as the local grocer or dry cleaner, might even prefer to advertise on these stations providing that

Trendata surveys show favorable low-power listenership in their area.

"We're showing things that have never been shown before," Baldwin said.

He explained that it is not only possible to track listeners in parts of a metro area for spot advertising, but to track how certain songs and personalities fare on a second-by-second basis. The computerized monitoring system can also show the demographic grid in the market, as well as the effectiveness of station billboard advertising. One Trendata computer can be set up before the billboard and another after.

Two medium-sized markets, as yet unelected, will be set up with the Trendata system in the coming months. From there, Baldwin said, it's on to Los Angeles.

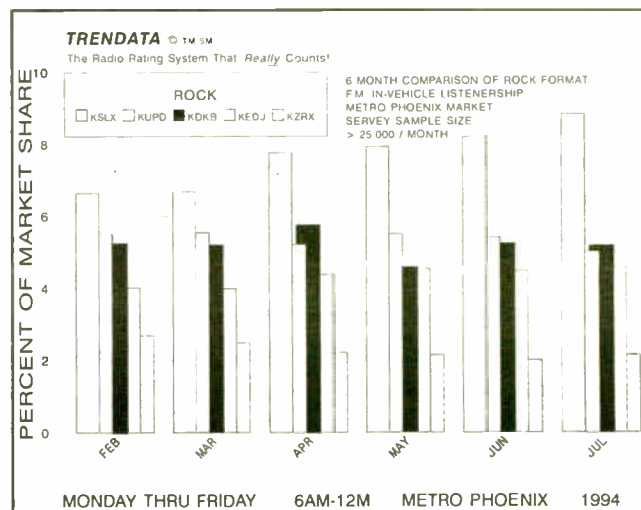

Eventually, the company hopes to wire the whole country with the system.

□ □ □

Dee McVicker is a freelance writer and regular contributor to RW. She can be reached at 602/545-7363.

A Special Commitment

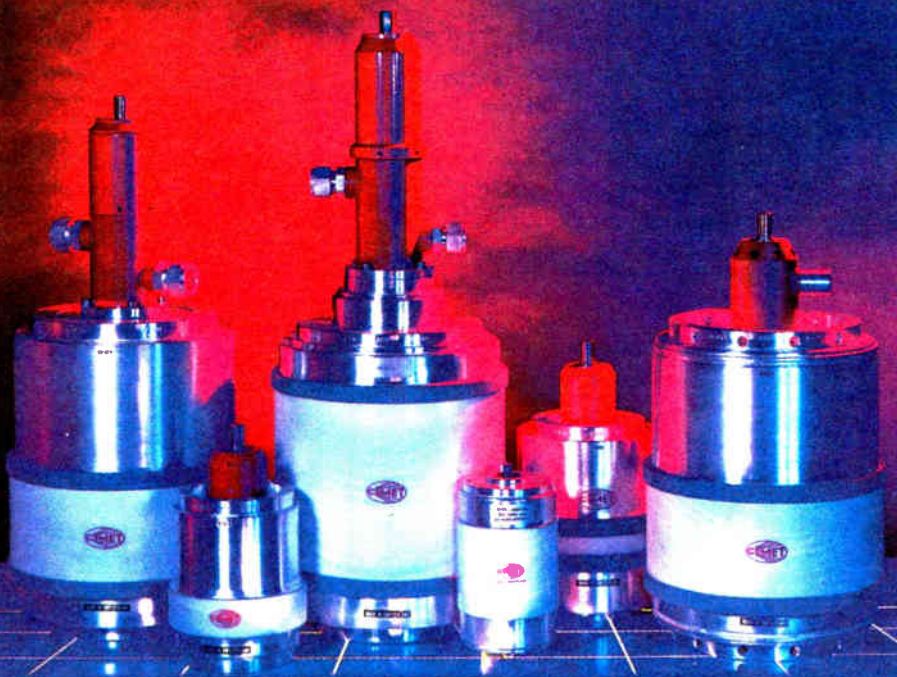

Since 1965, COMET has been committed to one objective — keeping our customers satisfied with the highest quality vacuum capacitors available.

Our experienced technical staff is dedicated to the advancement of capacitor technology, and will meet your custom requests with a design proposal in a matter of days. And, while we do specialize in made-to-order designs, we also stock a number of popular capacitor types for your off-the-shelf needs.

Call COMET when you have a special design request, want expert technical service, or need a replacement capacitor now.



COMET NORTH AMERICA, INC.

11 Belden Ave. • Norwalk, CT 06850 (203) 852-1231 • FAX (203) 838-3827

Circle (186) On Reader Service Card

RBDS

EASILY
INSTANTLY
INEXPENSIVELY

... with these two, brand-new products, INOVONICS has you covered, coming and going!

710 ENCODER: Just \$995 and *no computer required!* The non-volatile memory holds 16 separate frames of program and format identifiers, alternate frequencies, radiotext messages and traffic or emergency flags. A built-in data interface lets you upgrade later to full dynamic operation for revenue-generating paging, GPS, coupons, contests, etc.

510 DECODER: Connects to your existing FM Mod-Monitor. The front-panel LCD display shows RBDS injection level and allows you to scroll through and read all the data groups. An RS-232 port gives unlimited access to raw RBDS data for telemetry and other in-house functions.

SEE THEM AT WORLD MEDIA EXPO — BOOTH 1941

Inovonics, Inc.

1305 FAIR AVE., SANTA CRUZ, CA 95060 U.S.A.
TEL: (408) 458-0552 — FAX: (408) 458-0554



Circle (126) On Reader Service Card

See Us At WME Booth # 1941



The Dynamax MX Series

"E" Models From 8 to 18 Channels

New Beige Finish or Metallic Gray

- True modular design
- Ultra-reliable motherboard construction
- VCA mixer and monitor control
- Active balanced line inputs, transformer isolated mic inputs
- Active balanced main and monitor outputs
- Full monitoring/cueing facilities with VCA level control and active source selection
- Built-in cue amp with speaker and amplified stereo 8-ohm headphone output
- Independent remote start for each "A" and "B" input
- Opto-isolated remote module on/off
- Selectable fader start

- Two inputs per module, mic/line or line/line – line inputs may be mono or stereo, consumer or professional format
- Four assignable outputs – two stereo plus two mono
- Available in 8, 10, 12, 14, 16, or 18 channel models
- Independent level controls for each "A" and "B" input
- Separate audio and logic power supplies
- Sturdy, all-steel construction
- Durable Lexan overlay control surfaces
- Count-up event timer standard
- Two input expansion switches standard
- Excellent RF immunity

New
New

- Optional 5-band mic EQ module with pan
- Telephone interface module

New

- Studio talkback/monitor module

8:00 a.m. to 8:00 p.m. EST • 1-800-622-0022
 Canada 1-800-269-6817 • Toronto 416-731-3687
 U.S. & Canadian Fax 317-966-0623

HARRIS
ALLIED

Mastering the Art of Cold-Calling Sales

by Don Surath

SAN FRANCISCO There is no getting around it. If you want to be successful in sales, you will have to excel at cold calling. Because you are going to have to make the calls, why not take control and make yourself the best at this important part of the sale?

Here is what I do. Try this technique for a week and see the difference it makes.

To make calls more fun, think of cold calling as an opportunity to make new friends while enhancing your income. Try starting your calls as soon as you

arrive in the morning. It is a great way to start the day. Setting and reaching short term goals is a great motivator. Set a goal for yourself at either a number of calls per day or number of appointments made.

Getting through

When first calling a prospect, simply ask, "Who is in charge of advertising?" Get the information and hang up. Call the next day and ask for the person by his or her first name in a way that insinuates intimacy. Sometimes the person is in and will take the call. Most often it will take

at least two calls to get through.

Now is the time to meet the receptionist. This person is going to be your best

Think of cold calling as an opportunity to enhance your income.

friend. Get a name and write it down in the same permanent place you are recording information about the prospect. From now on call and say, "Hi, Denise, is

Carol in?" You will stand out as a person who deserves to speak to her boss.

Call often. Most buyers worth calling are overwhelmed by salespeople of all stripes. You have already taken the step of being the receptionist's friend. Now you must prove your mettle by calling until you

reach the prospect.

That means twice per day for two or three days. Such persistence will pique the prospect's interest. If you call once a week, the prospect will never remember you. If you can't get through, ask the receptionist when you should call, and she may help arrange to put your call through.

Common ground

When you finally reach Carol your job is to search for common ground. Start with the tone of your voice. Mirror hers as closely as possible. People like others who are like themselves. Listen carefully for clues. Is she just back from, or going on vacation? Where was it?

"I've always wanted to go there. How long? Your kids went too? How old are they? Are they good swimmers?" Stop at this comfortable topic and show interest. You'll learn something valuable while helping your prospect relax.

The personal topic is not important. The key issue is to focus the discussion on the prospect. Your goal should be to talk no more than 30 percent of the time. As Carol talks, she starts to relax. After she realizes that you're a human being, your discussion will be as equals. There is no need to say anything about your station. Save that for your first in-person meeting. If she asks you to tell her about your station say, "There'll be time to talk about my station when I come to see you. I called today to introduce myself and to find out about you and your business."

Do not set a time limit on a first conversation. The longer the conversation, the more you know about your prospect and the easier the rest of the sales cycle will become. That doesn't mean telling Carol your life story. Listen for clues that she's ready to get off the phone. Then ask for a face to face.

In person

A successful way to ask for the face to face is to say, "I'd like to visit and find out if there is common ground between your company and our station. I have a 2 p.m. appointment near you on Tuesday. Could I stop by either before or after that meeting to see you?"

If Carol says Tuesday is bad, you have a meeting sewn up. All you have to do now is agree on a meeting date. Ask her to give you a date that is better for her. When she gives it, tell her that you may have to move a couple things, but you think it will work. Say, "I'll call Denise later today to confirm your alternative." Don't appear over anxious by accepting the first date she proposes. Give them impression that you have a tight schedule by checking back later.

After you have confirmed the meeting with Denise, send a handwritten note

continued on page 84 ►



Let the VRC-2000 watch your remote transmitter site.

This is Mary Beth, your babysitter. Sure, she's great at tossin' a frozen pizza in the oven, finding *Knot's Landing* reruns, and tucking the kids in. But would you trust her with your "baby" at the transmitter site? With millions of dollars of equipment and thousands of dollars of FCC fines and downtime at stake, watching over your remote transmitter isn't your average babysitting gig.

The answer is the VRC-2000 Remote Control from Gentner. It not only monitors your transmitter, it can make changes for you automatically. If something goes wrong, it calls you or your technical staff to report the problem. Usually the problem can then be fixed by the VRC-2000, as you talk to it through your phone or your PC. Plus, you can access the



VRC-2000 from virtually anywhere. It's like having a person on duty at your remote transmitter site 24 hours a day, only it's more reliable and won't get cheese on the equipment.

Utilize the VRC-2000 to monitor and adjust everything you need at your transmitter, then relax — the babysitter's on duty. Call 1-800-945-7730

for more VRC-2000 information. And while on the line, ask about Gentner Conference Call Services.

 **Gentner**

The World Leader in Broadcast Telephone Interface Products

Products & Services Showcase

For more information on the products shown below, circle the appropriate Reader Service No. (s) on the enclosed Subscription/Reader Service card or contact the advertiser directly.

ARE YOU LOOKING FOR A COST EFFECTIVE ALTERNATIVE TO MANUFACTURER SERVICE?

SERVICE, REPAIR & CALIBRATION

- STL's • RPU's • TSL's
- Exciters • AM/FM
- Broadcast Monitors •
- Remote Control Systems

SPECIALIZING IN EQUIPMENT BY

- Belar • Marti •
- Moseley • McMartin
- TFT • And others...

> An authorized
TFT service center <

IN CASE OF EMERGENCY

We can help get you back on the air with our STL Loaner Program. We have STL's available that will be set to your frequency prior to shipping. We also provide over-the-phone technical assistance.



2198 Hubbard Lane, Grants Pass, OR 97527

(503) 471-2262

READER SERVICE NO. 54

Unique!

Shively FM Antennas offer standard features often unique in the industry: Our unique fine-matching transformer, included as standard equipment on Shively commercial antennas, can correct VSWR mismatches of up to 1.5:1 to compensate for tower effects. Unlike most others, it is tunable both under power and pressure, so it requires *no* disassembly of the system, and *no* adjusting of taped slugs for tuning. This means a better match, with less rigging time and costs. Watch future issues of **Radio World** for other unique Shively features.

Shively Labs

A Division of Howell Laboratories, Inc.

19 Harrison Road, Bridgton, ME 04009
207-647-3327 FAX 207-647-8273

READER SERVICE NO. 8

CircuitWerkes would like to thank our customers for making 1994 a great year. Look for us and exciting new additions to our products at the NAB fall show in booth 1819.

Think of *CircuitWerkes* for affordable and reliable autocouplers, DTMF & subaudible tone decoders, simplified telephone remote controls & the TeleRadio.

CircuitWerkes



6212 SW 8th Place
Gainesville, Florida 32607
(904) 331-5999 / fax (904) 331-6999

CircuitWerkes' products are available from these outstanding distributors:

- Audio Broadcast Group
- Bradley Broadcast Sales
- Broadcast Supply Worldwide
- Broadcaster's General Store
- Consolidated Media Systems
- Crouse-Kimzey Co.
- Graysonics
- Hall Electronics
- Harris/Allied Worldwide
- Northeast Broadcast Labs
- RAM Broadcast Systems
- S.C.M.S., Inc

READER SERVICE NO. 178

Affordable Custom Broadcast Furniture



2 Pennsylvania Avenue, Malvern, PA 19355

Delivered and installed by

STUDIO TECHNOLOGY

TEL: 800-676-0216

FAX: 610-296-3402

READER SERVICE NO. 200

REMOTE EASIER & SAVE



Resellers welcome

TWO x 64 ISDN TA

\$995

without internal NT1

\$1245

with internal NT1

- Backlit LCD (2 lines by 16) and 3x4 keypad
- Two V.35 interfaces for two 56/64 kbps channels
- Keypad, Preset and Quick Dial. ATD. RS-366A, V.25 bis, or X.21
- Supports DMS-100, 5ESS and NI-1 switches
- Optional X.25 (PAD) 9600 baud at Control Port

TELEPOWER

6451 Independence Ave., Woodland Hills, CA 91367

Tel: 818-587-5540 FAX: 818-587-5546

READER SERVICE NO. 118

PORTABLE OFF SITE EBS MONITOR \$350⁰⁰

Tuneable AM/FM Receiver and FCC Certified Decoder Model C.D.



Ideal for use during hours of unattended operation at the studio and transmitter site. With modern remote control equipment the alert message can be put on the air with a telephone.

Decoder in a minibox (price \$250⁰⁰) is available for use with receiver of your choice, or the decoder can be driven by phone line audio.

Gorman Redlich Mfg. Co.

257 W. Union St. Athens, Ohio 45701

FAX 614-592-3898 • Phone 614-593-3150

READER SERVICE NO. 135

AUDIO BROADCAST GROUP, INC. introduces the dramatically redesigned for 1994/95 Data Stream Series of our exclusive "Digital Ready" Studio Furniture. Created specifically for the efficient housing and operation of today's digital hard drive storage/studio automation systems and workstations. Our designers have combined the ultimate in functional work space and eye pleasing appearance.



AUDIO BROADCAST GROUP, INC. Supplying broadcast equipment and studio systems with integrity to the broadcasting community for over 33 years.

AUDIO BROADCAST GROUP, INC. Your single source supplier of AM/FM studio packages, AM/FM transmitter installations, as well as all major lines of on air and production studio equipment.

For additional information on how we can serve you, please call today

MAIN SALES OFFICE

2342 S. Division Avenue
Grand Rapids, Michigan 49507

Phone: 800-999-9281

Fax: 616-452-1652

SOUTHEASTERN SALES OFFICE

200 Fareway Drive, Suite 2
Smithfield, North Carolina 27577

Phone: 800-369-7623

Fax: 919-934-8120

WESTERN SALES OFFICE

P.O. Box 1638
Palmdale, California 93550

Phone: 800-858-9008

Fax: 800-273-3321



For over 33 years

AUDIO BROADCAST GROUP

READER SERVICE NO. 201

Love of Radio Keeps DJ Coming Back

Passion for Radio Began Early in Life from Long Days Spent Listening to Radio Giants like WABC (AM)

by Alan Haber

WASHINGTON This is based on a true story. I say "based" because many of the details of my first tour of duty in the radio jungle are a bit hazy.

Before I got into the writing business, I used to be a disc jockey. Actually, I still am—now a volunteer DJ at WCXS-FM, 94.5 MHz, a public access radio station in Fairfax, Va. The station, however, is on the local cable system.

I know the DJ thing sounds like some kind of admission of addiction, and, come to think of it, maybe it is.

My original DJ career began in the mid 1970s. Following two years on the air at WVHC-FM (now WRHU-FM) at my alma mater, Hofstra University in Hempstead, N.Y. in 1975-76, I headed for the state generally known to New Yorkers as one of the states you drive through to get to Florida—Delaware. There, I worked at WKEN(AM) in Dover for a few months in 1977-78. It was then a sort-of beautiful music station and is now playing now oldies. I then moved onto WAFL-FM in Millford, 1978-1981, which at the time was a country station. It is now an adult contemporary station.

Deep roots

I'm a radio junkie from way back. I grew up on New York's Long Island, my

ears glued to personality powerhouse WABC(AM). I loved everybody on the station, from Herb Oscar Anderson (or

WABC is the reason why radio is still in my blood and is my defining characteristic.

HOA, as he was known) to Big Dan Ingram (the best one-liner guy in the business) and Cousin Bruce Morrow. WABC is the reason why radio is still in my blood and is my defining characteristic.

I had a radio station in my house when I was a kid. I hung signs directing people down the hall leading to my bedroom-studio that identified my bastion of broadcasting (I'm sorry to say I don't remember the call letters). It wasn't a real radio station. I didn't even have a microphone. I just pretended to be a DJ back then. (Some people would say I'm still pretending.)

My love affair with radio continued through high school and to my college days at Hofstra University, where I was the Saturday afternoon DJ on WVHC. I

also wrote and produced a weekly, satirical "how-to" show called "The Sore Thumb Hour," which only ran for a half-hour, and was pretty funny, as I remember, and I have the tapes to prove it.

I thought about turning my passion for radio into a career after college, but chose to take the sure thing and live at home and procrastinate for a while instead. Then, seemingly moments later, I got my WKEN job through my mother's cousin's husband, who was then a newscaster for ABC

Radio network news in New York City (didn't every jock get started this way?)

On the doorstep

Upon arriving in Dover, the Delaware state capital, I pulled my AMC Gremlin

continued on page 88 ▶



Before. . .

Mastering Cold-Calling

▶ continued from page 82

thanking Carol for her time and confirming the time of the next meeting. When you arrive, both Denise and Carol will be eager to meet you because you are not like so many boring salespeople they have encountered. You are a breath of fresh air and a potential friend.

To review:

- Call to find the name of your contact.
- Call back and ask for the prospect by first name.
- Become a friend of the receptionist.
- Call twice a day for up to three days.
- Mirror the prospect's voice to establish rapport.
- Zone in on topics of personal interest to the prospect.
- Talk no more than 30 percent of the time.
- Be specific about the date and time

you wish to visit.

- Don't appear to be overeager to accept their alternative time.
- Follow up with a handwritten note.

Try this cold calling technique with 20 calls a day for one week. They don't all have to be cold calls. They can be folks on your list you've been neglecting or buyers you've been unable to crack. Make the calls, and you will be amazed at your success.

□ □ □

Don Surath is an award-winning salesman, sales manager and sales trainer. He has set records for finding new, direct business in the tough San Francisco market. Surath is currently a salesman at KKSF-FM San Francisco. You can reach him at 415-788-2022 or 415-824-2420.

TRUE BLUE FOR THE VIEWS.

Talk radio pros expect the unexpected, but there's one thing they can always depend on—the reliability of true blue.

audiopak
BROADCAST CARTRIDGES

P.O. Box 3100 • Winchester, VA 22601
Tel: (800) 522-CART or (703) 667-8125
Fax: (703) 667-6379

Circle (160) On Reader Service Card

A Broadcast Industry

BEST BUY

Mono Record / Play Stereo Record / Play

\$1420 \$1640

F.O.B. Factory

DL Series

AUDI-CORD CORPORATION
1845 West Hovey Avenue, Normal, Illinois 61761 USA
Phone 309-452-9461 - Fax 309-452-0893

Available Through Your Regular Distributor

Circle (1) On Reader Service Card

QUALITY AM ANTENNA PRODUCTS

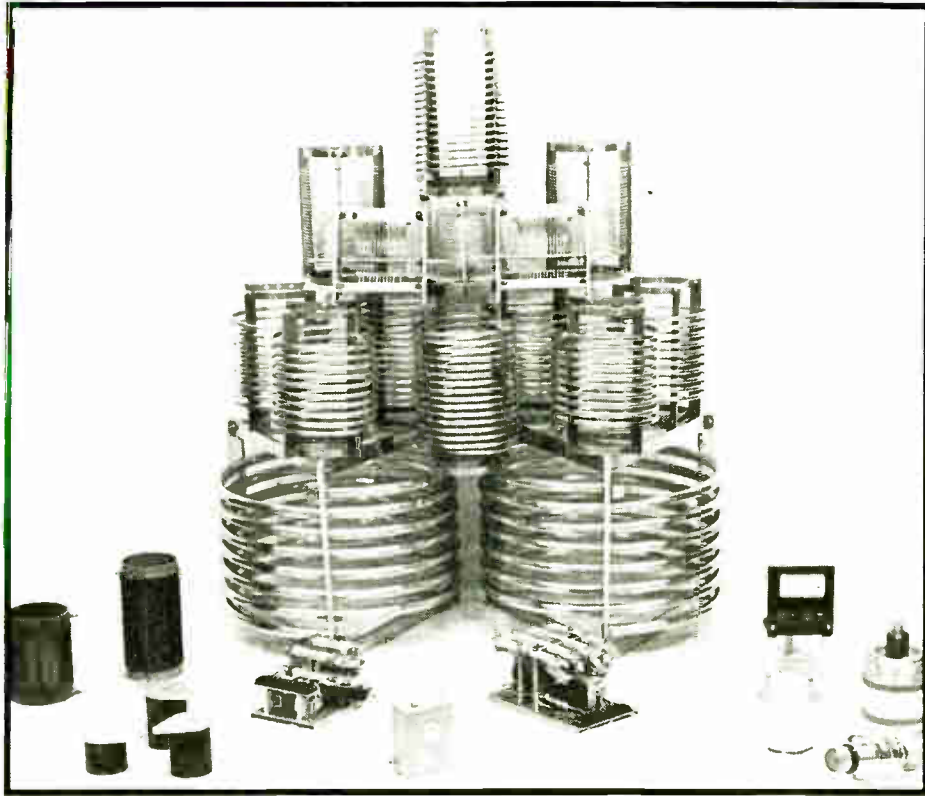

COMPONENTS

- Inductors
- Capacitors
- Lighting Chokes
- Static Drain Chokes
- Contactors
- RF Plugs & Jacks
- Meter Switches
- Insulators
- Antenna Sample Loops
- Equipment Boxes
- Copper RF Wire, Tube, and Strap
- Coaxial Cable, Feeder Systems



Offered in a wide variety of types and ratings, LBA RF Components are intended for application in Medium Wave/AM antenna and transmitter equipment with power levels to over 500kW. LBA products are built to the highest standards to ensure long life and reliability.

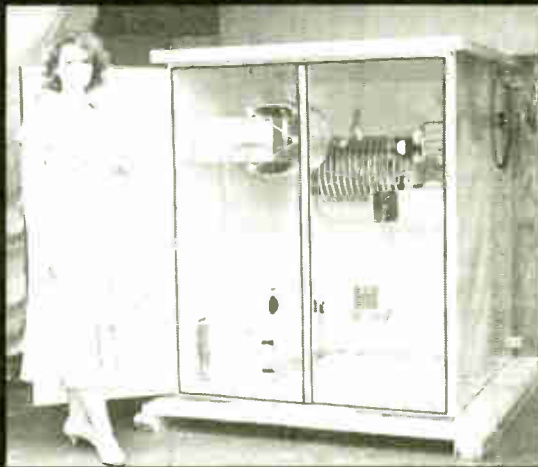

Antenna Tuning Units -
Combiners - Matching Networks

ANTENNA EQUIPMENT

- Tunipole™ Folded Unipole Antennas
- Combipole™ Multiple Frequency Antennas
- Detunipole™ Detuning Systems
- Antenna Tuning Units, Diplexers, Triplexers
- Transmitter Combiners
- PowerTopper™ Toploading Systems
- Basemax™ Base Enhancement Systems

LBA is the world leader in single and multiple station folded unipole antenna systems for high efficiency, wide-band AM transmissions at all power levels. LBA systems are found worldwide from Alaska to Argentina, Kuwait to Saipan.

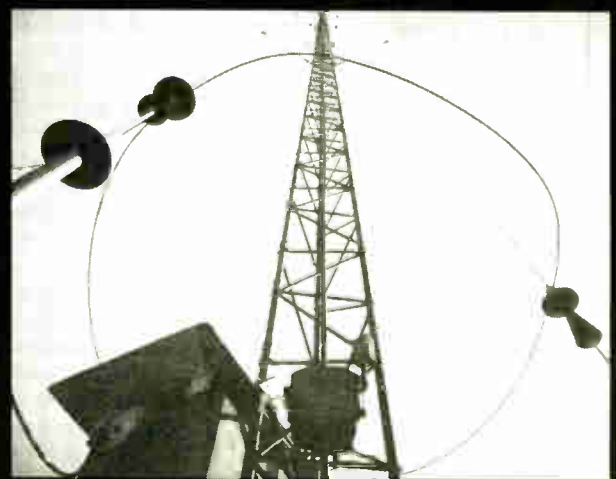

TUNIPOLE™ - Folded Unipole
Antenna Systems



LBA Technology, Inc.

210 W. Fourth Street • P.O. Box 8026
Greenville, North Carolina 27835

FOR FAST AM RF RESPONSE - CALL US!
TOLL-FREE
800-522-4464

919-757-0279 • FAX 919-752-9155

©1994

An LBA Group Company

Se Habla Español

Bring 286 Workhorses Back to Life

by Richard Mertz

FAIRFAX, Va. I have inspected many radio stations over the years. These inspections usually include tours of the studios, offices, public file and so on. My tour guide is always the station engineer so my visit to the facility always ends up in the engineering workshop.

No matter which one of the various engineering shops I've been standing in, one thing always stood out, a stack of old 286 PCs in a corner or under the workbench. As traffic software and sales presentation programs required more sophisticated and faster computers, the older 286-based workhorses were relegated to the storage shelves in the shop only to attract dust.

Dusty, but not dead

These leftover machines can, with the equivalent of a heart transplant, continue serving the needs of the station. To paraphrase an old expression "One man's garbage is another man's gold."

What would the general manager say if you were able to breathe some new life, at a reasonable cost, into the unused machines? By changing the older computer's motherboard with a newer, more powerful one and adding some memory, a piece of equipment that was once gathering dust can now provide additional computing power to the station.

The upgrade could be performed for much less than the cash outlay for a new machine or two-and-a-half-times your normal spot rate for those who like to trade.

How much does it cost? Ask any of your friends that frequent the local computer shows, computer flea markets and Hamfests and they will tell you where to find the components you need at an affordable price. I've seen 386-based motherboards priced under \$100 and RAM memory at about \$34 a megabyte. The cost of improving the older computer will depend on how many of the original adapter cards and disk drives you can salvage from the original machine.

Shopping for the parts can be as simple as looking in the newspaper. Here in the Washington area, the Washington Post prints a weekly business section. It looks more like the pages of Computer Shopper. There are ads for the usual larger computer retail chains, but there are also ads from smaller locally owned shops and where I've found some of the best prices. For those into flea markets, garage and moving sales, the best place to look for "deals" is in the classified ads.

What will you need to get? Well, first determine how the restored computer will be used. What software are you going to run? For this exercise, let's say you are going to be running WordPerfect 5.2. This is the Windows version of the popular WordPerfect 5.1.

Windows requires a minimum of 4MB of RAM memory. So we will be looking for a 386-based motherboard with at least 4MB of RAM. I recommend using the "DX" version motherboards over the "SX" version. The increase in speed is noticeable. The difference in cost is usually about \$20. For a simple task like

word processing the ISA style motherboards are fine. If we were going to run more sophisticated graphics programs, then an ISA or EISA motherboard with VESA support should be considered.

Assess your needs

Next, we need to consider program and data storage requirements. I'm sorry, we need to determine how big a hard disk drive and what type of floppy drive will be put into the upgraded machine. Many of the older 286-based computers used 40MB or 80MB hard drives. Many of these hard drives were usually MFM-style drives.

If the computer you will be upgrading has an 80MB drive, stop here. You may

The 286-based workhorse PC can, with a new heart, continue to serve your station.

be able to get away with using a 40MB hard drive, but be careful. Using the smaller drive would leave little room for your files.

Let's put one of these old machines on the bench, loosen the screws holding the top cover, and take a look inside. The machine I will be describing is the typical PC clone available all over. With the floppy drives facing you, on the left side of the case are the motherboard and adapter cards. To the rear of the case and to the right is the power supply.

It has been my experience that most 286-based computers used 200 watt power supplies. The floppy drives were usually 1.2 megabyte 5 1/4-inch, 720 3 1/2-inch drives, or some combination of the two. The hard drives were mostly 40MB or 80MB in size. Some older machines had faster IDE hard drives.

The computer we are working on has a 200 watt power supply, a 1.2 megabyte 5 1/4-inch floppy drive, an 80MB MFM

hard drive, interface cards for the floppy and hard drives, an EGA video card and a 2400 baud modem. Looks like we can salvage just about everything. Because more and more software is being distributed on 3 1/2-inch 1.44MB floppies, we will need to add the appropriate disk drive.

To upgrade our computer we will need a 386 DX motherboard, 4MB of RAM memory, and a 3 1/2" high density floppy disc drive with mounting adapter. The cost for all this is just under \$300. With cash in hand and a little haggling you may be able to get this cost down. I can't stress enough the need to shop around.

Ready to start

OK—we're ready to begin. First, *make sure the power is off and the power cord is removed.* Second, there are electrostatically sensitive devices on the old motherboard, the adapter cards and the disk drives, so be sure to ground yourself by first touching the computer case.

Loosen and remove the screws that hold the floppy drive in place. Carefully remove the cable that runs from this drive to its adapter card. Unplug the four-pin power plug. Slide the drive towards you. I'll bet it's full of dust. Carefully remove the dust with a small paint brush and a vacuum. A little liquid cleaner should make the plastic escutcheon look like new.

Do the same with the hard drive. The procedure is similar to the floppy drive except that there is an additional cable that runs to the hard drive adapter card. Dust off this drive in the same way we did with the floppy drive.

Next month, we'll continue with the cleaning and upgrading of the older computer.

□□□

Richard Mertz is a principal at the consulting engineering firm of Suffa and Cavell, Fairfax, Va. He can be reached at 703-591-0110 or through Compuserve, 73020,3026.

NEW!

LEVEL A 0.59 dBm LEVEL B 0.47 dBm PHASE A-B 0.1 deg

-15.00 dBm AUTORANGE 15.00 dBm

PORTABLE ONE

AUDIO PRECISION QUALITY IN A PORTABLE TEST SET

PORTABLE — AFFORDABLE — EASY TO USE

Just press a button and take a measurement!

- amplitude
- noise
- THD + N
- IMD*
- phase
- frequency
- wow & flutter
- generator load
- two-channel level
- amplitude ratio
- crosstalk
- AC mains check

The Portable One—a two-channel analyzer at the price of single channel competitors!

\$4,000*

Audio precision

P.O. Box 2209, Beaverton, OR 97075
503/827-0832 1-800/231-7350
FAX: 503/641-8906, TELEX: 283957 AUDIO UR

*includes IMD option or soft case



Circle (183) On Reader Service Card

AUDIO BROADCAST GROUP WELCOMES CUTTING EDGE TECHNOLOGIES

CUTTINGEDGE



Featuring the Unity 2000 FM and Unity AM Processors and Dividend Composite filter. The systematic processing package for the 90's.

Please call today for full color brochure and ABG pricing.

AUDIO broadcast group Inc.
MAIN SALES OFFICE
2342 S. Division Avenue
Grand Rapids, Michigan 49507
Phone: 800-999-9281
Fax: 616-452-1652

AUDIO broadcast group Inc.
SOUTHEASTERN SALES OFFICE
200 Fareway Drive, Suite 2
Smithfield, North Carolina 27577
Phone: 800-369-7623
Fax: 919-934-8120

AUDIO broadcast group Inc.
WESTERN SALES OFFICE
P.O. Box 1638
Palmdale, California 93550
Phone: 800-858-9008
Fax: 805-273-3321

Circle (47) On Reader Service Card

There are many reasons for choosing AEQ products. Here are just a few.

Control and Flexibility in your Remote Event Transmission



The AEQ Portable Mixer MP-10

- ▶ Ideal for remote event transmission.
- ▶ Easy to install and operate.
- ▶ Provides portability and autonomy.
- ▶ Carrying case included.

Special features:

- ▶ Five transformer balanced inputs selectable Mic / Line.
- ▶ Front panel input controls.
- ▶ Capable of linking mixers together to increase number of inputs.
- ▶ Transformer balanced outputs.
- ▶ Internal Ni-Cd rechargeable batteries provides 4 hour autonomy.
- ▶ Automatic switch to battery if power fails.
- ▶ Dialing keypad, dual mode Tone / Pulse.
- ▶ Three headphone output jacks.

Stereo Quality Monitoring at Mono Price

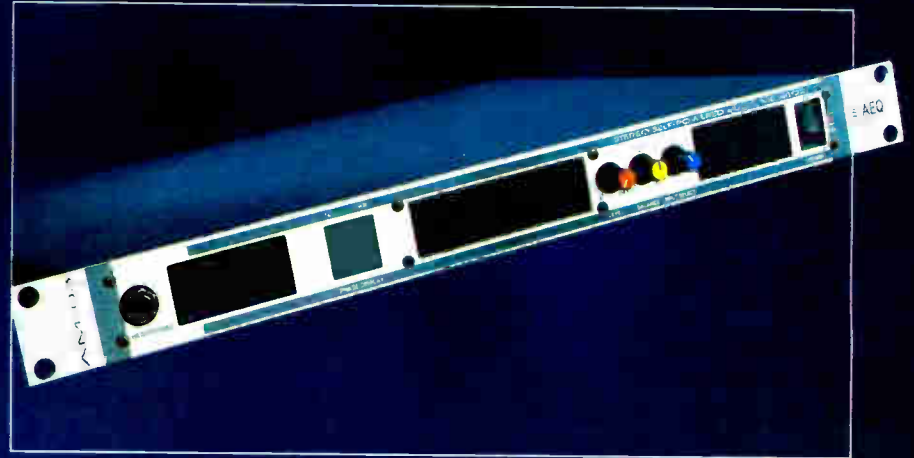

The AEQ AM-03 Stereo Audio Monitor

- ▶ Designed to meet the monitoring needs of technicians working in VTR rooms, OB vans, radio and TV controls, etc.
- ▶ All the controls are in the front panel to facilitate easy and accurate operation:

Input selector (three selectable stereo inputs).
Output channel selector and balance.
Gain control and power switch.

Features:

- ▶ Three way audio system (mono for low and stereo for mid and high frequencies), consisting in five speakers. All contained in one unit 19" rack space.
- ▶ Electronically balanced inputs and output, with XLR connectors.
- ▶ Incorporated limiter for speakers protection.
- ▶ Audio phase meter.
- ▶ Headphones connector with automatic speakers disconnection.

The Ideal Combination



Digital Telephone Hybrid AEQ TH-02 EX

- ▶ Frequency Extender Mode as standard feature.
- ▶ Works with one or two telephone lines.
- ▶ The second line provides full Multiconference Mode. The operator and two callers can talk and listen to each other simultaneously.
- ▶ Hybrid null of 60 dB's.
- ▶ No adjustment required.
- ▶ Ideal companion to work with AEQ Portable Digital Line Extender TLE-02.

Portable Digital Line Extender AEQ TLE-02

- ▶ Clear Air phone call with audio presence, depth and clarity of voice. No "telephone sound".
- ▶ Easy to use. Designed for the non-technical user.
- ▶ Ideal for field reporters, totally portable. Light weight: 3.3 Lb.
- ▶ Great operation autonomy, using 8 AA batteries.
- ▶ Dialing pad in front panel, and Pulse / Tone selectable.
- ▶ Independent level control of Mic / Line input, auxiliary input and headphones.

Value & Performance



AEQ Mixing Console BC-500

- ▶ The AEQ Mixing Console BC-500 is designed for those radio stations seeking great audio quality at a competitive price. Its designers paid great attention to the control layout; the logical control design ensures a quick learning period as well as a trouble free operation.
- ▶ Advanced true modular design allows total flexibility. The module chassis has built-in meters and speakers and comes in a standard configuration with the following capabilities:

- ▶ Six dual stereo inputs.
- ▶ Four mono inputs Mic / Line selectable.
- ▶ One Telephone Hybrid interface.
- ▶ Studio control Intercom monitor.
- ▶ One main stereo output plus mono sum output.
- ▶ Power supply for On Air signaling.
- ▶ The AEQ BC-500 comes with 4 blank modules to enhance this configuration.



AEQ AMERICA, Inc.: 2211 South 48th Street, Suite H - Tempe, AZ USA 85282
Phone: 1 (602) 431 0334 - Fax: 1 (602) 431 0497

INSIGHT-ON-RULES

Keep on Top of Needed Documentation

by Harold Hallikainen

SAN LUIS OBISPO, Calif. A review of documents received through a Freedom of Information Act request shows that in November 1993 an AM station in West Virginia received a Notice of Apparent Liability (NAL) for \$5,800 for violation of three FCC Rules. Let's look at the details of this NAL to help you avoid these situations at your station.

The station was fined \$1,500 (adjusted down from a base amount of \$2,500) for failing to conduct a partial proof-of-performance as instructed by the FCC. An

additional \$550 was assessed (adjusted down from a base amount of \$5,000) for use of a square-law ammeter with a full scale reading greater than three times the minimum normal indication. Finally, the station was assessed \$3,750 (adjusted down from a base amount of \$5,000) for failing to have its most recent issues/programs list on file.

Notice of violation

Following an inspection, the station received a Official Notice of Violation outlining several problems: The inspector found that determining power by the direct method yielded a power of 5563

watts while the indirect method yielded 5049 watts. The direct method power is about 10 percent above the indirect method power. The FCC has not specified how closely these power determination methods must match, but it appears 10 percent deviation is too much. The station was cited for a violation of 73.45(c) because the mismatch between power determination methods could indicate a change in antenna resistance (or could indicate a change in transmitter efficiency). The station was directed to make antenna resistance measurements and submit FCC form 302, if appropriate.

The inspector found that the base current ratio on one of the towers of the directional antenna was 27 percent high. Section 73.62(a) requires antenna monitor loop current ratios and actual antenna base current ratios to both be kept within 5 percent of the licensed values (unless tighter tolerances are specified on the

license). This appears to be a relatively common violation. Many stations rely entirely on their antenna monitor indications. I'd suggest, however, that antenna base currents be logged along with calculated ratios and deviations from licensed ratio every time the transmitter site is inspected.

In its response, the station said that it suspected the incorrect base current ratio and the apparent change in antenna resistance (actually, common point resistance) were related. This is probably true. The station further states "Our antenna monitor at the studio has given no indication of a problem... I had no reason to suspect any problem at the tower sites." True, I'd expect incorrect base current ratios to cause incorrect antenna monitor readings, but don't count on it. Check those base currents.

The station further responded that it was having difficulty finding the original proof (which is required to conduct a partial) and was being delayed by poor weather. The station said it would keep the FCC advised of progress on the problem. You

continued on page 96 ▶

WHEN QUALITY COUNTS



It has to be apt-X100 - the only true single chip audio compression solution - adopted by the world's leading manufacturers of broadcast equipment.

In professional broadcast, telecommunications and recording applications, the benefits of APT's predictive audio compression system are clear. Higher resistance to tandem coding errors, lower coding delay and a higher immunity to data errors mean less noise - so if you need to exploit the advantages of compression without risk - you'll be using the most appropriate solution. For details of both single chip and board level solutions - call APT.

Audio Processing
Technology
Edgewater Road
Belfast BT3 9JQ
Northern Ireland
Tel 0232 371110
Fax 0232 371137

Audio
Processing
Technology



Audio Processing
Technology
6255 Sunset Boulevard
Suite 1026
Los Angeles
CA 90028 USA
Tel 213 463 2963
Fax 213 463 6568

apt-X and apt-X are registered trademarks of APT

DJ Keeps Career Alive

▶ continued from page 84

up to an Arby's for a bite to eat. The kid behind the counter immediately fingered me as a New Yorker. Was my New York accent that strong? No, as it turned out—the guy had just seen my license plate.

Short but semi-sweet

My career in big time radio at WKEN was short and semi-sweet—I was new to the radio game (at least to the professional arm) and I was from the big city, so to speak. Beautiful music didn't seem so beautiful to me. But I did learn how to work a board (a pretty simple model, as I remember). I would wake up 15 minutes before my Sunday morning shift and drive 80 or 90 miles an hour to get to the station on time to kick in the transmitter and perfect my DJ patter. I also learned how to mispronounce local geography (New-irk instead of New-ark).

Not surprisingly, five short months later (more or less), I was on the air about 30 miles further south—on country format WAFL or "Waffle Radio" as we called it. Whereas I was on a pretty tight leash at WKEN, I felt unleashed at FM 97, and I had a lot of fun.

I "gave away" WAFL "14-karat-gold rubber bands" on the first April Fools Day I was there. Even though I clearly stated on-air that the giveaway was an April Fools prank, a woman drove her son about 25 miles in pouring rain to pick up her rubber band. The station gave her a T-shirt or some other bauble for her trouble. I had to write the station's call letters on an entire box of rubber bands. It took a long time, and my hand cramped up something awful. But I did learn my lesson (something about the circumference of rubber bands versus the rate of speed that ink emerges from a pen point).

I spent three great years at "Waffle Radio." We broadcast every summer

live from the Delaware State Fair, where I interviewed people like the guy who claimed he owned the world's largest alligator, and a female hog-calling champion, who let go with a hog call that had my ears ringing for the rest of the day.

In March of 1981, I moved back to New York with my wife. Even though I physically wasn't in radio any longer, I wasn't able to get radio out of my blood. Still, it



...and after

took me 13 years to do something about my addiction: I went back on the air with a once-a-week show on WCXS-FM.

First, though, I had to pass a broadcasting class at the station. I was terrified when, during the first class, I found myself suddenly sitting behind the board. But I had nothing to fear—it all came back to me in a flash. I was a DJ again! And, in case you're wondering, the public access radio experience is not unlike the commercial radio experience. I'm still dealing with a live microphone, and there are still people listening (I hope).

I like this DJing so much, I'm even thinking about trying to get back on the air on a part-time basis at a commercial station. I'll keep you posted.

□ □ □

When he is not on the air playing his eclectic mix of Frank Sinatra and the Beatles on WCXS, Alan Haber is a regular contributor to RW.

IT'S ALL IN THE AudioVAULT.®

Only AudioVAULT OnLINE™ systems provide *all* the important digital audio capabilities radio stations want.

Integrated Cut-and-Paste Editing: Perform simple production on AudioVAULT with no additional software. Optional: the AudioVAULT MTE™ eight-track editor, with seamless Windows interface.

Business Connection: AudioVAULT OnLINE connects with your traffic and billing system and music rotation software. You'll save time and reduce mistakes.

Power On-Board: The AudioVAULT Multi-processor System Board incorporates Digital Signal Processing (DSP) and fast SCSI interfaces for simultaneous multi-user access to your digital audio. Its AES-EBU inputs and outputs effect perfect transfers.

Windows™ On-Screen Control: Clear, consistent Windows interface system speeds the addition of new functions and accelerates staff training.

Windows is a trademark of Microsoft Corporation.

Central Audio Storage with Dynamic Access™: All audio cuts are instantly available to all studios, even while you're recording new material.

Versatile Automation Interface: AudioVAULT easily connects with automation controllers like BE CORE™ or Format Sentry™, plus online news editors and routing switchers.

Programmable Controls: Production audio cuts, telephone and network recording, even transmitter or studio lights can be assigned to on-screen buttons or console switches.

For complete information on AudioVAULT OnLINE Digital Audio Systems, call (800)426-9082; Fax (206)441-6582.

Solid Company;
Solid Support: BE
builds it; BE backs
it. 24 hours a day
forever.

BE® BROADCAST ELECTRONICS, INC.

WORLD LEADER IN RADIO BROADCAST TECHNOLOGY

2211 Fifth Avenue • Seattle, WA 98121 • (206)728-2741 • FAX (206)441-6582

Upgrade Old Dynacos with Van Alstine Kit

by Doug Fearn

POCOPSON, Pa. Back in the 1960s and 1970s, Dynaco manufactured thousands of good-quality vacuum tube consumer preamps and power amps.

With the renewed interest in vacuum tube equipment by professionals and consumers, vintage Dynaco equipment is sought after by audiophiles, particularly those who want "tube sound" but cannot or will not pay the thousands of dollars for current production vacuum tube gear.

Several years ago, audio designer Frank

Van Alstine, president of Audio by Van Alstine, recognized the potential for upgrading several of the Dynaco products. In addition to manufacturing new vacuum tube, solid state and hybrid pre- and power amps, Van Alstine offers rebuild kits for the Dynaco Pas-3, Pat-4 and Pat-5 stereo preamps; the St-series solid state power amps and the all-tube, 35 watts-per-channel St-70 power amp. The upgrades can be performed at the Van Alstine factory (with your working amp), or you can get the necessary parts and instructions in kit form.

Radio World Managing Editor John Gatski found me a well-worn PAS-3 and a St-70, which were in pretty good shape cosmetically, but in need of help inside. They were perfect for the rebuilds.

Pre-upgrade listening

When I received the stock equipment, I decided to listen to them and make some measurements for later comparisons. For source material, I had twenty-five years of studio masters to choose from, plus CDs. My monitors were a pair of UREI 811s (15 inch with coaxial horn in a bass reflex cabinet — a very efficient system).

After connecting the system and turning it on, there initially was a low level clicking sound that disappeared. There also was significant 120 Hz hum and ground loop buzz that did not go away. The stereo balance was off several dB in favor of the right channel. And the old corroded RCA connectors on both units were an occasional source of extreme hum.

The stock Dynaco system lacked deep bass, and the recordings seemed to be missing the top octave. I also noticed a lack of musical detail. But the sound of the old gear was still pleasant—in a rounded-off kind of way.

The kits

I obtained two separate rebuild kits: one for the PAS and the other for the St-70.

The PAS kit, called the Super Pas Three, was extensive (\$245 retail) and included line, phono and power supply cards, precision parts, new volume and balance controls and an AC cord. Ordered options included gold jack set (\$60 retail) and a new faceplate and knobs (\$75 retail), which were to be installed by the factory. The St-70 kit (\$195 retail) consisted of a new main board with components, new B+ supply, bias supply and driver tubes. The only options I utilized were new input and output jacks (\$40).

The Van Alstine approach should benefit those who enjoyed building Heathkits years ago, and who also want to save some money. But don't expect Heathkit-style instructions with these kits. The upgrade kits are for experienced electronics technicians or advanced hobbyists. Any broadcast engineer who performs troubleshooting and repairs at component level, however, will have absolutely no trouble.

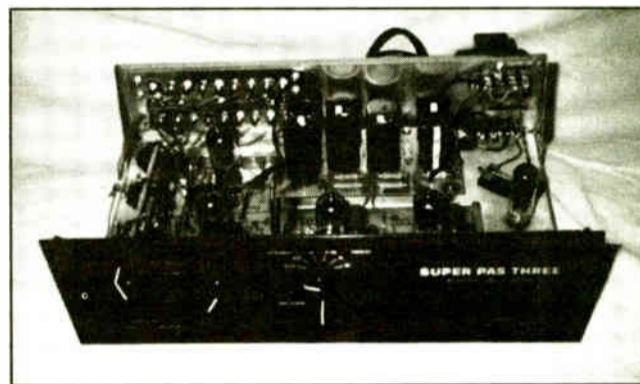

Audio by Van Alstine kit can transform a PAS 3 into a Super PAS Three.

Rebuild kits mean you have to deal with old equipment with sometimes fragile components and wiring. Fortunately, Dynaco originally offered both of these units as kits, so there are no complicated assemblies or tight spots inside. Because the unit you choose to upgrade may have been built from a kit, you could run into some pretty sloppy construction or poor

soldering, depending on the skill level of the builder. In my case, the preamp was factory-wired and the power amp was kit-built.

The factory-wired unit was easier to work on because most of the internal wires were simply stuck through the connection hole and soldered. However, the factory used riveted-in connectors and printed circuit boards, and removing these posed some problems. A carbide burr on an electric drill, as recommended in Van Alstine's instructions, did the job, but it was slow going.

The power amp wiring was not very good. In fact, I was amazed that it worked with all those cold solder joints.

The preamp

The instructions first call for loading the two PCBs, which is a good way to find out if you are up to the challenge. The components used are quality grade.

Nothing is esoteric (no special capacitors or oxygen-free wire), just good, solid, quality parts such as film coupling capacitors, Noble-detented pots, Dale metal film resistors and fiberglass circuit boards.

Most of the parts are not marked with component values or color codes, just manufacturers' codes. These codes make sense if you're used to them, but they

prevented me from finding the right part without several referrals to the parts list.

After the new circuit boards were finished and cleaned, the disassembly of the preamp began. And it is a total disassembly. Basically you have an empty box, the transformer (which is moved to the outside back panel), rectifier tube and some controls that get used again.

Nearly everything replaced

The upgrade replaces just about everything in the audio path and eliminates the tone controls, filter switch and loudness switch. The input selector switch is rewired to eliminate obsolete sources (e.g., "Tape Head") and adds additional CD and Spare inputs. The volume and balance controls are replaced with the wonderfully smooth Noble detented pots.

The new jack set should be considered mandatory, unless they have already been replaced. The jacks posed my only real problem with the project. The instructions tell you to tighten the nuts on the jacks "firmly." I broke the first two before re-calibrating myself as to what "firmly" meant. Fortunately, there were two extra jacks in the kit.

It took me about twenty hours to complete the preamp rebuild. The unit was sent back to the factory before it was turned on. The factory techs inspected the work and fired it up to see if it performed properly. They also installed the new black faceplate and knobs (if you chose that option) and painted the chassis a matching black.

The factory found one error in my work. One circuit board was supposed to be mounted on the under side of the chassis

continued on page 92 ►



LMA/DUOPOLY CONTOUR MAPS

The **DATAWORLD** LMA/DUOPOLY Market Survey Contour maps present a precise electronic verification of overlapping and intersecting contours.

AM 5 mV/m and FM 3.16 mV/m City Grade contours are shown in full color, including transmitter site indicator. The map is supported with a printout showing all of the stations which appear on the map.

Daily updating of **DATAWORLD'S** AM and FM databases protects against errors and omissions.

OTHER MAP OPTIONS

- SHADOWING (TERRAIN SHIELDING)
- CONTOUR COVERAGE
- POPULATION DENSITY
- ZIP CODE BOUNDARIES
- RECEIVED SIGNAL LEVEL
- SPECIAL REQUIREMENTS

1990 CENSUS

WHO ARE YOUR LISTENERS?

1990 BUREAU OF CENSUS POPULATION COUNTING

- Comprehensive Ethnic and Demographic Data
- Ethnic/Demographic Data Available for Each Zip Code Within Coverage Area
- Age Analysis Reflected in Ethnic Breakout
- Resolution Increased to Block Level
- Percent of County Coverage Shown

ETHNIC PIE-CHART DISPLAY

- Projects Ethnic Population in Multi-Color Pie Chart Form

dataworld®

800-368-5754 FAX: 301-656-5341

Do You Want A Better Sounding Station?

CRL CAN HELP YOU. No matter the size of your station or the size of your budget, we have an engineered solution for you.



Call Today!

Give your station that distinctive sound you need to build bigger audiences.



Circuit Research Labs, Inc.

(602) 438-0888

FAX (602) 438-8227

Amigo FM. Feature by feature the Amigo offers the best value in today's market. The Amigo has the ability to give any station a "big station" sound at half the cost of typical FM processors.

f FOCAL PRESS

Focusing On Your Needs

1-800-366-BOOK

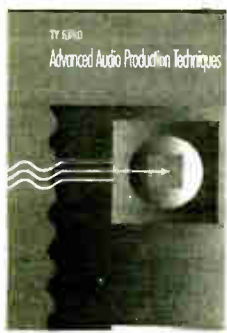

Advanced Audio Production Techniques Ty Ford

Provides precise, easy-to-understand answers to how and why sophisticated audio decisions are made. Explains how to create concepts and use today's audio technology to achieve "audio pictures" in the mind of the listener. By using visual language charts and graphs, Ford offers a multi-dimensional approach to the realization of practical concepts that are the basis of good audio. Even without a strong technical background, the reader will be able to operate complex audio systems successfully. Also contains interviews with award-winning producers. Written for the video age, this book will show the reader how to visualize sound.

\$24⁹⁵

160 pp.
(0-240-80082-6)



The Radio Station Third Edition Michael C. Keith and Joseph M. Krause

A concise, refreshingly candid, and comprehensive guide to how radio stations and the radio industry work. This new edition updates and expands one of Focal Press' most successful broadcast titles, a book acclaimed by both the industry and academia. The book provides a comprehensive blueprint of the modern radio station, detailing the functions successfully performed within every well-run station. Readers will understand not just how their own particular job is best performed, but also how all these tasks mesh. This edition features an extensively revamped art program and text, including a half-dozen new sections, and dozens of new industry quotations.

320 pp. **\$34⁹⁵**
(0-240-80159-8)

The Art of Digital Audio Second Edition John Watkinson

The first edition of this book is now regarded as a classic in its field. Because of the fast-moving nature of the technology described, the new edition has now been completely updated to include all the latest developments, including DCC, the mini disc and digital audio broadcasting. Completely rewritten as a result of extensive feedback, the book now begins by introducing the reader to digital audio in a more user-friendly way.

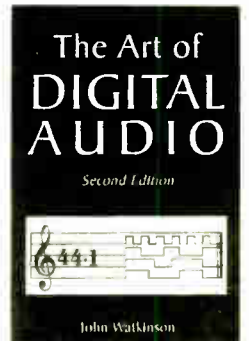

490 pp. **\$59⁹⁵**
(0-240-51320-7)



MIDI Systems & Control Second Edition Francis Rumsey

Since the first edition of the book was published, a great deal has happened in the field of electronic music and there have been many additions to the MIDI specification. This second edition has been updated and enlarged to take these changes into account. Additional material covered includes: General MIDI, MIDI machine control, integration of digital audio and video, computer hardware, software and interfaces, mixer automation, an introduction to synthesis and sampling, information on all the latest additions to the MIDI specification, and practical systems design.

\$29⁹⁵

256 pp.
(0-240-51370-3)

The Sound Studio Fifth Edition Alec Nisbett

For many years, this book has been the classic text for practitioners and students in the field of sound recording. Now completely updated and rewritten, it includes much more information on the use of digital equipment and many new illustrations. Each theme is carefully discussed in non-technical terms; the principal criterion throughout is developing judgment by ear.

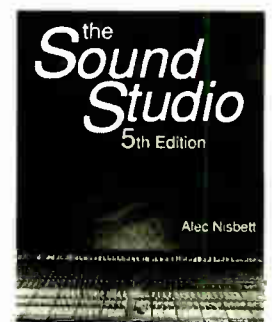

480 pp. **\$39⁹⁵**
(0-240-51292-8)

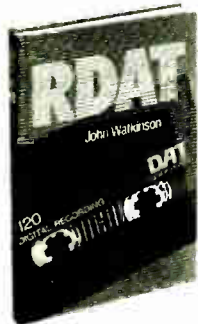

R-Dat John Watkinson

The continued trend in all disciplines towards digital technology is nowhere more apparent than in audio tape recording, where R-DAT has brought true digital quality in a size and cost range hitherto thought impossible. R-DAT is not only a professional recording format, but also an instrumentation recorder and computer data recorder. This unique, comprehensive book describes R-DAT in its various guises and explains fully the principles involved in its operation. Theory is balanced with practical examples and details of the tape format are complemented by descriptions of the transport design and control. The clarity of the explanations makes this an ideal book for newcomers to the technology as well as those already expert in the field.

\$69⁹⁵

240 pp.
(0-240-51306-1)

No Risk!
30-day return policy
if you're not completely satisfied.

To Order Call Toll-Free:
1-800-366-2665
Monday-Friday, 8:00 a.m.-6:00 p.m. Eastern Time
Or Fax Your Order to 617-933-6333
Indicate Reference #SS141 when ordering

SS141

GOOD NEWS FOR AM

from

KINTRONIC LABS

We can help you take advantage of the new FCC Duopoly Rules and LMA opportunities.

Diplexing is today's solution!

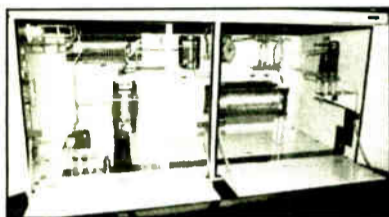

Typical AM Diplexer

Just listen to New World Radio's Jim Weitzman:

"When we purchased WUST-AM, we knew we'd have to move the transmitter and antenna, and increase power, to cover the entire metro area. Our best bet was to share another station's existing antenna.

Using our host station's four-tower site meant we needed a diplexer, and tuning networks and traps on the other towers to prevent reradiation and intermodulation.

Only one company could meet our needs: Kintronic Labs.

The result? No surprises. After initial installation and adjustment, the Kintronic Labs equipment at WUST has worked so well we sometimes forget it's even there."



Jim Weitzman
President
New World Radio,
WUST-AM
Washington, D.C.

With more than 30 years in the RF business, you can trust **Kintronic Labs** for expert antenna design, hardware and installation.

Take hold of AM's new opportunity.

KINTRONIC LABS
144 Pleasant Grove Road
Bluff City, TN 37618
615-878-3141

Circle (112) On Reader Service Card

Upgrade Old Dynacos

► continued from page 90

and I mounted it on top. The error was corrected at no charge. I checked the instructions afterwards, and they were clear.

Van Alstine evidently believes, as I do, that the simplest circuit that will do the job will probably sound the best. Careful attention to coupling capacitor values, feedback parameters, grounding and power supply decoupling can make all the difference in the sound of an amplifier. A single 12AX7A dual triode is used for each channel, and another pair of 12AX7As for the phono preamp. These tubes are readily available. The new power supply utilizes the 12X4 rectifier of the original, but uses silicon diodes for the filament supply. All the filter capacitors are replaced in the rebuild, and the filter circuit is improved.

Power amp kit

In the St-70 rebuild (actually it is a modification), there is less disassembly involved. Total kit time was about ten hours. The new circuit board is wired into the existing circuit with a plethora of wires that make it difficult to do a neat job. The wires used are solid, not stranded, which initially caused me some concern about durability during transport. But the trip to the factory in Minnesota and back to the East Coast caused no problems, so I guess it will last a while.

The optional new input and output connectors should be considered mandatory if your amp still has the poor-quality factory parts. The new connectors are five-way binding posts capable of handling much larger gauge wire. I did not opt for the optional power transformer/rectifier diode bridge option that eliminates the 5AR4 rectifier tube.

Power amp circuit

The Van Alstine general circuit scheme appears to be similar to the original St-70 design: a pentode input stage followed by a triode phase inverter that feeds a push-

pull output stage. The sonic improvement is evidently gained from improved components and better circuit design parameters. The output stage is essentially unchanged. (Van Alstine said the amp has always been a 25 watt-per-channel (RMS) amp not 35.)

The original circuit used 7199 tubes for the input. These are becoming increasingly difficult to find, so the Van Alstine version uses 6GH8A tubes, which are easier to obtain.

Upon completion and a thorough doublecheck, the amp was sent back, rechecked and sent back to me—approved by the factory.

Listening tests

I actually built the preamp, sent it back to the factory and got it back before I upgraded the St-70. Therefore, I paired the completed PAS-3 with the stock St-70 to see if there were any sonic differences from the stock listening sessions. There were. Almost all the noise was gone. At full gain there was just a slight hiss and a hint of a ground loop buzz in the speakers, which came from the stock St-70. The balance was perfect with the "Balance" control centered. But overall, the pairing was still significantly bass-deficient and dull. The sound was quite pleasant, however, and for non-critical monitoring or background use, it was the kind of audio you could listen to all day without fatigue.

After the St-70 rebuild, however, there was a world of difference. The bass was much improved. Now I could get stuff on the shelves in my listening room to rattle at moderate levels. The highs were better too, although they seemed a bit harsher than they did before the upgrade. That harshness, however, may be attributable to the improved amp's ability to reveal defects in the recordings that weren't noticeable before.

If something different in the monitoring system reveals new details in a recording

I am familiar with, it generally indicates an improvement. The upgraded Pas-3 and St-70 surprised me by revealing some nuances that I had never noticed before such as reverb.

The only deficit I noticed while using the upgraded amps was that they did seem to lose some of that "I could listen to this forever" quality. This is probably due to the improved high frequency response.

For a second opinion, I took the upgraded gear to the home of my sales manager. He has Vandersteen Model 2 speakers, normally fed with a Crown D-75 amp. We listened to some CDs with the Crown, fed directly by the CD player, and then switched to the Dynaco Super Pas-3 and St-70.

The bass did not seem quite as full on the Dynaco set-up, and my sales manager said it did not reveal as much detail as the crown. He preferred the solid state amp overall, but agreed with me that the Dynaco amp made his speakers easier to listen to for long periods. Except for the loss of some low end, I preferred the tube set-up. To my ear, the solid state amp was more analytical, but the tube amp was more musical.

Conclusion

The Dynaco rebuild kits from Audio by Van Alstine provided a dramatic improvement in the sound of the units I upgraded. Low- and high-end frequency response were improved. Clarity and detail were enhanced. Noise of all types was reduced. The Super Pas Three pre-amp looks great with the new front panel and knobs. I especially like the feel of the new volume and balance controls. The gold input/output jacks and binding post speaker connectors should improve reliability and reduce noise. Overall, these kits are a practical way to achieve modern vacuum tube performance levels at a reasonable price.

Audio by Van Alstine also offers factory installed versions, which are a bit more expensive. Bare PC boards and plans are also available. For more information, contact Audio by Van Alstine at 612-890-3517; or circle **Reader Service 153**.

528E Voice Processor — Make a big impression.



Voice Symmetry.

High Definition Mic Pre-Amp.

Compression.

Downward Expansion.

De-Essing.

Parametric EQ.

Voice talent is expensive. So why not get your money's worth?

Scan any AM or FM dial in the U.S. or Canada and you'll hear Symetrix voice processing technology at work. Creating better sounding voices. Attracting more listeners. Everyday.

The new Symetrix 528E continues our tradition of providing broadcasters with powerful, reliable, easy to use tools.

Six processors in one box. From the company who invented "voice processing".

A voice is a terrible thing to waste.

Total voice control. All in one box.

Symetrix

Tel 206.787.3222 Fax 206.787.3211
Toll Free 800.288.8855

Circle (79) On Reader Service Card

Products & Services Showcase

For more information on the products shown below, circle the appropriate Reader Service No.(s) on the enclosed Subscription/Reader Service card or contact the advertiser directly.

The CircuitWerkes AC-12 Telephone Autocoupler Bay

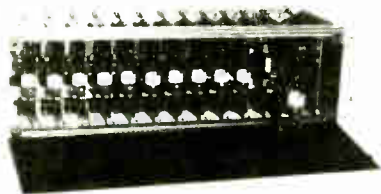

Get up to 12 couplers in a neat, compact chassis

- > Auto answer & disconnect.
- > 2 audio busses for mass feeds.
- > Individually card selectable buss or auxiliary audio I/O.
- > LED indicators for ring, clipping, power & online.
- > Ring counter answers on user settable ring number.
- > Momentary or latching dry contact outputs at pickup.
- > Remove & install cards without affecting the rest.
- > A special, non-bussed, balanced audio card for IFB feeds, etc., is available.

The AC-12 rack-mounted coupler bay is the best way to eliminate a wall or cabinet full of yesterday's couplers. Our unique dual audio busses eliminate the tedious and messy wiring associated with networks and other mass feeds. Each card can also individually either send or receive telco audio. Best of all, a fully loaded AC-12 lists for under \$185 per coupler.

CircuitWerkes
6212 SW 8th Place
Gainesville, Florida 32607
(904) 331-5999 / fax 331-6999

READER SERVICE NO. 163

ANNOUNCING FOR FALL '94
THE ONLY ADJUSTABLE POP FILTER FOR RADIO



Variable Acoustic Compression™

"Aesthetically Excellent, Sonically Satisfying."

Human Numan, Z100 New York

"Well, your new design has certainly eclipsed the old. As soon as I saw one, I just had to put them everywhere! Not only is it better looking and less obtrusive visually, but it installs much easier. And they still cut the 'pops' without muffling the highs. Best of all for us, your new clip-in design lets the ZeeJays pop their 'Popless' screens in and out in a flash!"

David P. Reeves III, Chief Engineer, Z100 New York

- Greatly reduces popping and sibilance
- DJ's sound clearer and need less equalization
- Washable and replaceable screens
- Easily adjusts for each DJ
- protects your microphone

\$49
plus shipping

POPLESS
VOICE SCREENS
PO Box 1014
New Paltz, NY 12561

TOLL FREE (800) 252-1503
MONEY BACK GUARANTEE Call for FREE BROCHURE

READER SERVICE NO. 20

MAGNETIC HEADS NAB CART REEL-TO-REEL

- HWRA cores: 3-5 times the life of mumetal/hyumu
- Balanced windings: for optimum S/N and hum rejection properties.
- Filled epoxy: more stability and wear resistance.
- Proprietary lamination design: exceptionally smooth response curve, typically ± 1 dB, 35-16,000 Hz
- SPC-based manufacturing: consistent products, excellent yields, minimum variations.
- Design flexibility: specifications adjustable to customer requirements.

MEC cart heads are always as good as the originals...and often better.

1-800-433-8522

MEC

Mag-Head Engineering Co.
686 Mendelssohn Avenue
Golden Valley, MN 55427

READER SERVICE NO. 143

AUTO-ANSWER TELEPHONE COUPLER

Ideal for unattended situations such as listen lines, IFB feeds, dial-up networks, remote transmitter sites & satellite links.

- Clean connection to phone line
- Easy to install
- Send or receive program
- F.C.C. registered



SEE US AT
WME BOOTH
#2182

COMREX®

Comrex Corp., 65 Nonset Path, Acton MA 01720
Tel: 1-800-237-1776 Fax: 508 635-0401

READER SERVICE NO. 180

SOLID STATE 2, 4 & 5 kW FM BROADCAST POWER AMPLIFIERS

CALL 800-986-9700

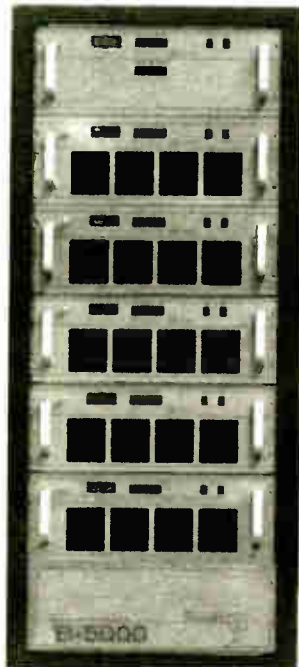

1KW INTERCHANGEABLE MODULES

2 YEAR WARRANTY

HARMONIC FILTER

5' RACK

MODEL	POWER
B-2000	1000 - 2200
B-3000	1500 - 3300
B-4000	2000 - 4400
B-5000	3000 - 5500



Silicon Valley
POWER
AMPLIFIERS

The RF People

800-986-9700 FAX 408-986-1438
529 FORMAN DRIVE, CAMPBELL, CA 95008

READER SERVICE NO. 123

The Audio World™ Interface from BENCHMARK

\$225



The Audio World™ Interface is a two-way recorder interface that is switchable to a line amp or a mono mix amp.

Both the balanced inputs and the electronic transformer outputs have front panel recessed gain controls. The rack mountable chassis includes LEDs to indicate signal presence, the onset of peak overload, switch position, and power presence.

Use it to mate R-DAT and analog recorders, to generate Mono from Stereo, or as a balanced line amplifier to compensate for level mismatches.

With its superlative performance and very, very low price, you'll find numerous applications for this versatile device.

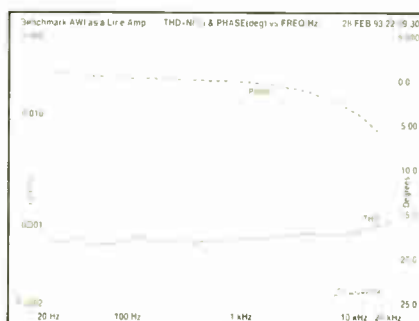

Benchmark
the measure of excellence™

SEE US
AT WME
BOOTH #2714

BENCHMARK MEDIA SYSTEMS, INC.
Phone 800-262-4675, FAX 315-437-8119

READER SERVICE NO. 11

Shape Up!

Coverage. Saturation. DBk contours. In FM broadcasting, the "bottom line" is always based on your pattern.

More than any other manufacturer, Shively has the experience and reputation for providing crucial pattern solutions for critical propagation problems. On any tower. At any power level. Remember, *it pays to be heard.*

A good pattern. The shape you need. Talk to your consultant. And contact us.

Shively Labs

A Division of Howell Laboratories, Inc.
19 Harrison Road, Bridgton, ME 04009
207-647-3327 FAX 207-647-8273

READER SERVICE NO. 203

FEEDLINE

Dealing with Cellular Re-radiators

by W.C. Alexander

What happens when someone builds a cellular tower near your AM array, particularly in the main lobe of your directional pattern? I found out first hand recently. With cellular networks expanding at an exponential rate nationwide, this kind of thing must be occurring all over. I hope that by sharing what I have learned I can help some of you deal with the problem.

Cellular systems are licensed under Part 22 of the FCC Rules and are administered by the Common Carrier Bureau. Even though the Common Carrier Bureau staff does not normally have anything to do with broadcast stations, someone at the FCC evidently realized the potential conflicts that can occur.

A Public Notice was released on August 11, 1987 titled "Standard Broadcast Reradiation and Tower

Construction Authorized Under Part 22 of the Rules." This Public Notice outlined the steps that Part 22 licensees must take when building within two miles of a directional AM array or 0.5 mile of a non-directional AM antenna. Let me summarize for you the requirements stated in the Notice.

Notify the AM

First, when the Part 22 station is within 0.5 mile of a nondirectional AM antenna: Prior to con-

struction, the licensee should notify the AM station.

The common carrier is responsible for installation/maintenance of detuning apparatus.

Antenna proof measurements must be taken both before and after tower construction to prove that the AM radiation pattern is undisturbed, including at least 10 measurements along eight equally spaced radials and antenna impedance measurements.

When the Part 22 station is within two miles of an AM directional station, the requirements are the same, except that a partial proof (as defined in 73.154) must be run on the array before and after construction. A final requirement is that the results of this partial proof must be filed with the Part 22 license application (Form 489).

Unaware of policy

Evidently, Part 22 licensees were either unaware of or were ignoring the FCC policy stated in this 1987 Public Notice, because the commission re-released the Public Notice in November of 1989, restating all the above requirements.

It is my opinion that this ignorance or disregard is still going on because a local cellular provider popped a 150-foot tower right in the main lobe of both our Dallas arrays, a little more than a mile away. Neither our chief engineer nor the station manager was notified of the construction. The new cellular tower was discovered during a routine site visit.

Had the cellular licensee followed the prescribed procedure, we could have worked with his engineers to make sure that our radiated patterns were not affected. Because he did not, however, there is no way to go back (short of dismantling the cell tower) and run the pre-construction partial proof. It will be much more difficult to determine whether any pattern distortions are due to the cellular tower or some other factor.

Pattern distortion

At the time of this writing, I still don't know the extent of the pattern distortion, if any. The common carrier has hired a consulting engineer to look at the situation, but nothing has been done as yet. Common Carrier Bureau personnel advised me that the commission would step in and sanction the Part 22 licensee if he failed to cooperate fully and remedy the problem according to FCC policy (albeit after the fact).

The cellular provider is cooperating at this point, so we will see how things go. I will pass along the rest of the story in a future column.

So what do you do when a cellular tower pops up near your directional array? First, find out who the licensee is. If the site is not identified with signage or you can't get the information from local cellular providers, plot the site on a topographical map and determine the geographic coordinates as best you can. With that in hand, you can contact the Common Carrier Bureau at (202) 653-5560 and personnel there can conduct a search.

continued on page 96 ►

Radio's Hottest Show... in Radio's Hottest Market!

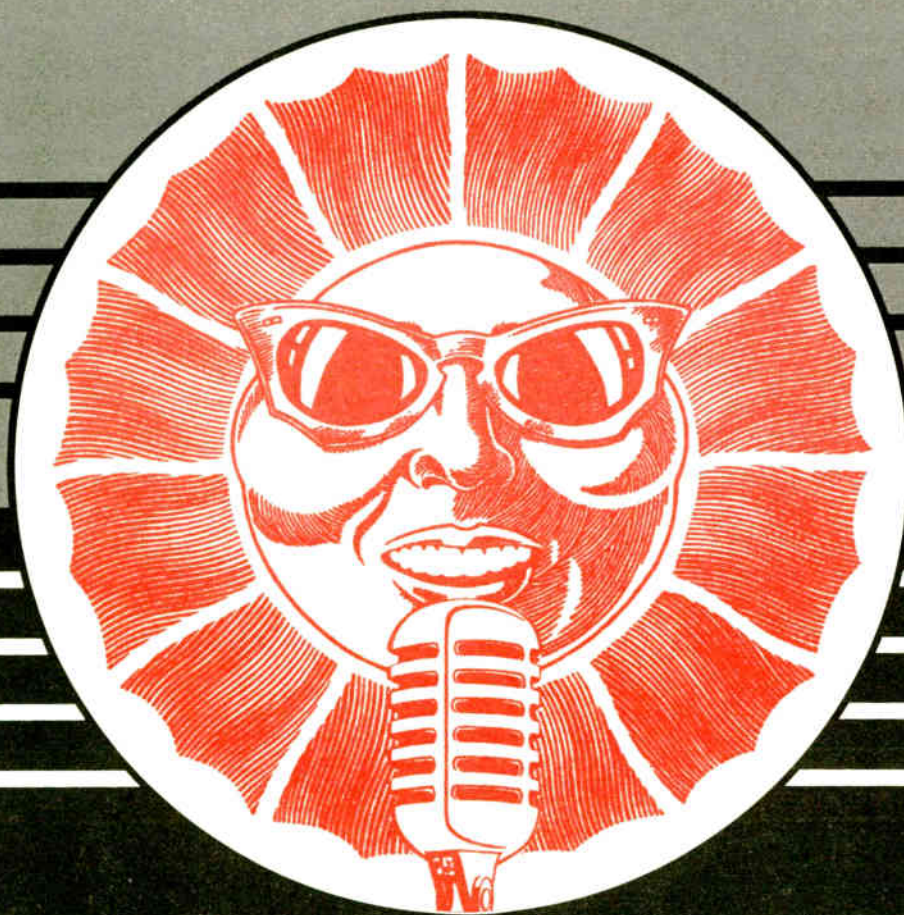

RADIO
THE NAB
SHOW

OCTOBER
12-15, 1994
LOS ANGELES,
CALIFORNIA

The NAB Radio Show offers you information-packed seminars and workshops that add up to more money-making radio management, sales and marketing and programming ideas than you can find anywhere else in the world.

You'll also have complete access to the exhibits at World Media Expo, and a special Radio/Audio Pavilion featuring equipment and products of special interest to your engineering and news operations.

REGISTER TODAY!

Call (301) 662-9400, ext. 1 or send a fax to (301) 694-5124. To speak with an NAB representative, call (800) 342-2460 or (202) 775-4972.

INFORMATION BY FAX

Call (301) 216-1847 from the touchtone handset of your fax machine and follow voice instructions.

EXHIBITOR INFORMATION

Call Eric Udler at (202) 429-5336.

JOIN NAB AND SAVE

Save \$290 on registration. Call (202) 429-5400.

SBE CONVENTION

Call the SBE Fax-On-Demand Service at (301) 216-1853.

SADiE 2.1

There's a lot more behind a SADiE™ than you might think. Our job doesn't finish when you purchase your SADiE™ system.

For a start you can telephone for advice, support or just a chat from early morning 'til late evening, seven days a week and because we combine our sales and service into one customer support operation, you'll most likely be speaking to the same person that sold you your SADiE™. And if your system stops working (don't let anyone tell you "breakdowns never happen!") customer support will get you up and running again as rapidly as possible. As our support team often work with clients on actual projects, we really understand SADiE™ and the pressures of audio production. Every SADiE™ user has the latest software - we know you are the best advertisement for SADiE™ so free software updates are a sound investment for all of us.

Finally, we don't try to make money out of maintaining your SADiE™ - an extended 3 year hardware maintenance contract will cost you less than \$1,500 and you don't have to purchase it until the end of the 12 month free maintenance period. The price of a SADiE™? - same as ever - a complete system for \$9,995 (plus the odd local tax, duty and delivery, where applicable)



It's the little things that matter

NEW IN VERSION 2.1

fader, pan and mute automation

auto-conforming

machine control

CMX support

even faster editing

background networking

playlist overview

CD-R support

all this in addition to SADiE's phenomenal editing and proven audio processing capabilities.



FOR FURTHER INFORMATION CONTACT:

Studio Audio Digital Equipment Inc
1808 West End Avenue,
Suite 1119, Nashville, Tennessee 37203 USA
TEL: +1 615 327 1140
FAX: +1 615 327 1699

SADiE™ DISTRIBUTORS WORLDWIDE

Argentina Kappa T 081 31 0818 F 081 31 1493 • Asia Pacific VW Marketing T +44 372 728481 F +44 372 724009 • Australia TVC T 09 249 6688 F 09 249 6858 • Canada JSGS Ltd. T 416 751 7907 F 416 751 7975 • Denmark SC Sound T 43 99 88 77 F 43 99 80 77 • Finland oy HedCom AB T 90 682 866 F 90 682 8489 • France Coach Audio T 87 77 00 00 F 87 77 01 21 • Germany Stefan Mayer Audio Engineering T 0 6851 6519 F 0 6851 6519 • Israel Sontronics Electronic Equipment T 03 5705223 F 03 6199297 • Korea Avix Trading Co. Ltd. T 02 565 3565 F 02 565 3561 • New Zealand Videx T 09 444 6085 F 09 444 3837 • Philippines Tracks T 2 631 3277 F 2 631 3267 • Poland Unico T +44 223 63025 F +44 223 301488 • South Africa Tru-fi Electronics SA (Pty) Ltd T 011 462 4256 F 011 462 3303 • Spain Lexon T 93 203 48 04 F 93 280 40 29 • Sweden Tranzicom T 08 730 3710 F 08 730 5125 • Switzerland Media Solutions T 064 41 57 22 F 064 41 00 35 • Taiwan Acesonic T 2 716 8896 F 2 719 2065 • Thailand KDM Trading T 2 318 2724 F 2 318 6186 • USA SADiE Inc T 615 327 1140 F 615 327 1699 •

*Windows is a registered trademark of Microsoft Inc. Studio Audio & Video Ltd reserve the right to change specifications without prior notice.

Monaural Audio in, Stereo Audio out

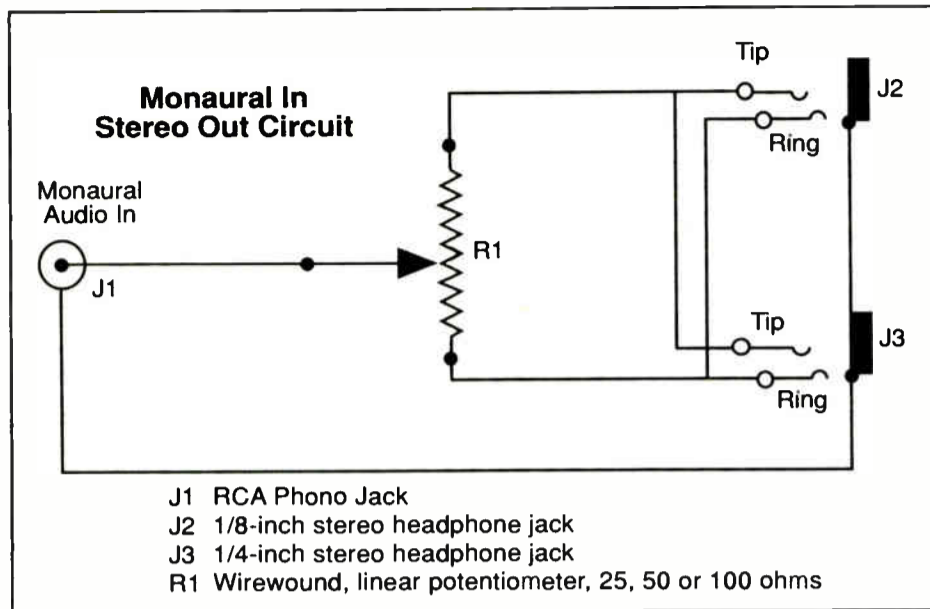

by A.W. Edwards

CORPUS CHRISTI, Texas I have noticed for some time now that all the really "neat" headphones—the high fidelity, comfortable ones with a large selection of styles—are designed for stereo listening. Yet many of us who listen to shortwave broadcasts and other transmissions prefer to use headphones and find that our choices in a monaural style are limited.

Uneven hearing

Not only that, but in my own case, I no longer hear equally well with each ear. The circuit I developed addresses both of these points. It provides a means of compensation for the differences in hearing levels. Persons with normal hearing may enjoy the nice headphones by centering

the balance control.

The circuit accepts monaural audio from the EXT SPKR or PHONES jack, introducing it via an RCA phono jack. I selected this type of input jack because so many selections of patch cords are available with the RCA plug on one end and a variety of connectors on the other (including alligator clips). The assembly easily fits into a small project box.

Choices in monaural-style headphones are limited.

The incoming monaural audio (level set at the receiver) is split, in effect, by the variable resistor R1, a linear, wire-wound type. Each end of R1 supplies audio to a separate earphone. The result is "the best of both worlds." You have discrete, adjustable levels available for each ear, and you have the whole catalog of headphone styles to select from.

Most popular models

The jacks shown are the most popular stereo models—1/4-inch and 1/8-inch sizes—to fit almost all headphone models. If you already know which headphone plug you are going to use, you may just wire in that size alone. Also, if you are the only person to use the device, you could determine the resistances on each side of the movable tap and substitute fixed values (1/4- or 1/2-watt size) for R1, but it is likely that you will want the flexibility of the variable resistance.

If you find, upon finishing the project, that left audio is coming out the right side, or vice versa, just reverse the wires going to the ends of the resistor. Again, the basic audio level is controlled at the receiver, while the balance control delivers a suitable audio level to each ear.

□ □ □

A. W. Edwards, K5CN, retired in 1992 as a ship radio operator. He holds First Class Radiotelegraph, General Radio telephone and Amateur Extra Class licenses. First call (1946) was W5KZG. He prefers operating CW but operates phone on several bands. He was an intelligence officer/electronics engineer with the CIA during the U2 years. Later he served as editor for three newspapers, and has published two books.

Dealing with Re-radiators

► continued from page 94

Next, contact the cellular company and try to work your way through its ranks to the person in charge of new sites. Discuss the situation with him, asking what has been done to protect your station. Ask the person if he has fully complied with the procedures outlined in FCC Report No. CL-90-40. If not, ask why not.

Reradiation

When talking with the cellular people, it would be good to have already determined the worst case re-radiation that the new structure can produce. If you keep old issues of *RW* (as I do), dig out the July 8, 1992 issue.

In that issue's *Feedline*, I dealt with re-radiation issues. There was even a sample calculation. The thing to remember is, if the power isn't there, it cannot be reradiated! The offending structure will just about have to be in either the main lobe or a substantial minor lobe in order to receive enough energy from the directional array to reradiate.

If it appears that the worst-case reradiation exceeds half the licensed inverse distance field on any given radial, it is likely that some detuning of the new structure will be necessary. Explain this to the cellular representative, and provide him with a copy of the Public Notice if he doesn't have one. I think it is a good idea to follow all verbal conversations with written communications. This provides a "paper trail" that you can point back to if the cellular company becomes uncooperative and you have to get the FCC involved. Send any such correspondence by certified mail to provide proof of delivery.

Corrective action

What is likely to happen? The cellular licensee should agree to hire a reputable consulting engineer with expertise and experience in detuning AM reradiators. This engineer should be someone acceptable to both you and the cellular company. The engineer will then go with you to look at your monitor points, antenna parameters and probably the cellular tower as well. He or she may make a set of field strength measurements to determine the actual

reradiated field produced by the cellular tower.

With this information in hand, a course of corrective action can be planned. This corrective action will likely start with the installation of a detuning skirt on the cellular tower followed by a partial directional proof of performance on your array. The end result should satisfy both you and the FCC that the cellular tower is having no effect on your array.

Many engineers will be glad to know that a rulemaking is in the works to codify the policy set forth in the Public Notice, giving it the force of law. The new rule will be designated 22.371 - "Disturbance of AM broadcast station patterns." I have no information as to when this will be implemented, but the process is underway.

Let me wrap up by quoting from the Public Notice: "The Commission's policy is clear. Whether by imposition of specific conditions or by operation of law, a licensee building a new facility is obligated to take all necessary steps, including the financial burden, to correct interference problems caused by new or modified construction."

There are several instances of case law

cited to shore up the policy. I interpret the phrase "including the financial burden" to be inclusive: the AM station should not be out one cent in dealing with problems caused by the construction of a cellular tower near its directional array. This is my interpretation: you should discuss the matter with your attorney to get the latest on the policy. If remedying the problem eats up 80 hours of your time, it is my opinion that the cellular provider should be liable to your employer for your time. The same goes for any down-time that the station may suffer in the process.

Cellular companies have become experts at constructing and activating new sites overnight. One day a crew will pour innocuous looking foundations; a week later, they come back with a crane and set a tower in place and offload a building with all the equipment already installed. Be alert for such construction near your AM site. Even though the cellular company is liable for correction of the interference, you could be liable for having parameters (including monitor points) out of tolerance. Keep your eyes and ears open!

□ □ □

Cris Alexander is director of engineering for Crawford Broadcasting. He can be reached at Box 561307, Dallas, Texas 75356.

Keep up with Paperwork

► continued from page 88

may want to start digging up a copy of the most recent proof and keeping it in your files, just in case.

This offer to "keep the FCC informed" led to more problems for the station when the offer was not fulfilled. In the Discussion portion of the 2 November 1993 NAL, the FCC said it had not been informed of any progress since the offer was made March 31. As such, the station was fined \$1,500 for failure to conduct a partial proof as instructed. Don't let your promises to the FCC fall between the cracks.

Meter scales

During an inspection in December 1991, the FCC noted that one of the base current meters was broken. During the inspection in February 1993, the FCC found that the defective meter had indeed been replaced, but the full scale indication was more than three times the minimum normal indication, in violation of 73.1215(b)(2). Whenever you replace indicating instruments, check the appropriate rule section for specifications on that instrument.

Stations are required to prepare a list of community issues and the programs addressing those issues each quarter.

During the inspection, the FCC found the lists were not present. The station responded during the inspection that the lists were at another (probably co-owned) AM-FM station in another community.

Each station is required to keep the list (and other public inspection file info) in the licensed community, so this did not fulfill the FCC requirements. However, the FCC checked the station in the other community the next day and found no list there, so now there were three stations in violation of this rule.

The issues/programs lists often may be read by only one person on the station staff who has read the rules (or has read this article?). So, check everything you can.

I'd look forward to getting copies of current violation notices and related correspondence from your station. By reviewing how the FCC is actually enforcing the rules, we can help ensure compliance at your station. Thanks for the help.

□ □ □

Harold Hallikainen is president of Hallikainen and Friends, a manufacturer of transmitter control and telemetry systems. He also teaches electronics at Cuesta College, San Luis Obispo and just returned from the Alta Sierra dance camp. He can be reached at +1 805 541 0200, fax +1 805 541 0201 or email ap621@cleveland.freenet.edu.

Broadcast Equipment Exchange

"Broadcast Equipment Exchange" accepts no responsibility for the condition of the equipment listed or for the specifics of transactions made between buyers and sellers.

RADIO RESOURCES

1201 S. SHARP ST.
BALTIMORE, MD 21230

PRE-OWNED EQUIPMENT LIST VIA FAX:
Just call 1-800-832-2329 ext. 737 to receive a faxed list of many fine equipment items currently available. The list will be updated on the 1st and 15th of each month.

NEED A COPY OF OUR TECHNICAL NECESSITIES CATALOG?

Call 1-800-547-2346 to request your free copy.

TEST EQUIPMENT AVAILABLE TO RENT:
Potomac Field Strength Meters
Tektronix Spectrum Analyzer (for AM splatter measurements)
Delta Impedance Bridge
Delta Receiver/Generator

HAVE EXCESS EQUIPMENT YOU WANT TO SELL?
We need late model AM/FM transmitters. Orban Optimods, Potomac Field Strength meters, STL and RPU equipment plus many other items.

Call Steve or Chuck
1-800-54-RADIO
1-410-783-4635 FAX

Circle (23) On Reader Service Card

AMPLIFIERS

Want To Sell

Phase Linear 4000 autocorrelation pre-amp, 2 front chan/2 rear chan outputs, 2 tape outputs, aux outputs, 2 tape/2 phone/tuner & aux inputs, provides AC for 6 devices, rk mt, \$125/BO; BGW @%)B stereo pwr amp, 100 W/chnl into 4 Ohm load, rk mt, \$125/BO; JVC FX-330 AM/FM computer controlled tuner w/quartz lock, LCD multimode display, up to 16 preselecs, \$100/BO, all 3 \$300/BO, all prices + ship. E Helvey, Summit Prod, 461 Layside Dr #100, Winchester VA 22602. 703-877-2717.

ACOUSTICS

Want To Sell

BAD SOUND SUCKS.
LUCKILY FOR YOU, WE INVENTED THE WORLD'S BEST ACOUSTIC FOAM.

Studiofoam Sound Absorbent Wedges
The industry's most absorbent foam! Uniform cut for clean & easy installation. Up to 60% more effective than other name-brand foams that can cost 5 times as much! Passes California firecode; 46% more flame retardant than Sonex. Available in 1, 2, 4 & 12 inch (base trap) sizes in 2'x4' sheets. Long-lasting, doesn't crumble like other brands can. Wide range of colors. What A Value!!!
1"-\$6.99, 2"-\$9.99, 4"-\$19.99

Soundmat Convulsated Acoustic Foam
Cut in the industry-standard "eggcrate" shape. 4"x6" sheets, 2 inch thick, charcoal gray (other sizes & colors by special order; call for pricing). 85% as effective as Studiofoam Wedges, but still beats other brands that cost up to 5X as much! Made of the same stock, so it retains their advantages with regard to flame retardancy, longevity and shape retention. Order in pairs only. Unbeatable value at just \$32.99 per sheet!

CALL FOR FREE SAMPLE KIT
1-800-95-WEDGE

Circle (46) On Reader Service Card

AMPLIFIERS

Want To Sell

Broadcast Technology Company
BT
PO Box 751
Lamar, Colorado 81052
tel: 719-336-3902

Fairchild rack mntd power supply, amps, preamps; rack mounted 4 amp bridging system. N Johnson, 92 Higgins Rd, Presque Isle ME 04769. 207-764-0605.

Funai DA-4 2 input, 4 input, audio DA, -10 dB, RCA inputs & outputs, bass & treble cntrls (8), \$15. G Dunn, N CA News, 5383 Willow Lake Ct, Byron CA 94514. 510-516-0299.

Sparta TPA-7, 25 W audio modules for MAS-50 monitor amps (3), \$40 ea or 3 for \$95. D Peluso, KJUL, 2880 E Flamingo Rd, Las Vegas NV 89121. 702-732-2200.

Lesk Stereo 50 tube type amp, tubes inc, excellent condition, \$600. J Robillard, WQUE, 2228 Gravier St, New Orleans LA 70119. 504-827-6000 ext 161.

Dynaco stereo 120 solid state, rack mt \$229, Dynaco stereo 70 tube amp all new tubes! Dynaco PAT 4 preamps \$59. W Gunn 619-320-0728.

Altec 128B tube power amps (2), \$275. D Miller, Airborne Audio Prod, 12209 W 88th St, Lenexa KS 66215. 913-492-8822.

Anchor 100 speaker amp, clean, \$50 + shipping & handling. G Hultman, 300 Limp Creek Rd, Grants Pass OR 97527. 503-474-6466.

Want To Buy

Urei 6500, 6300 amp; Crown D-75 amplifier; Symetrix A-220 amplifier. R Eskridge, Galaxy Recording, 1508 Harlem Dr, Memphis TN 38114. 901-274-2726.

B-500 BROADBAND FM AMPLIFIER

FEATURES:

- 100% solid state
- No tuning required
- Rugged power supply
- VSWR, current, & temperature overloads
- Power trim standard
- Full remote control capability, with outputs for all main parameters
- FCC notified
- 600 W max output

WANTED:

Pultec EQ's; Fairchild, Teletronix, dbx, UREI, Sontec Limiters. Neumann, Telefunken, AKG and RCA mics. MacIntosh or Marantz Gear; Lang, Neve and API gear. Misc old tubes and guitars.

DAN ALEXANDER AUDIO
1340 Mission Street
San Francisco, CA 94103
(415) 252-7102
FAX: (415) 252-7524

ANTENNAS/TOWERS/CABLES

Want To Sell

Shively 3 bay CP on 94.3, \$4000; Scala FM, \$150. D Rose, KDUC, POB 250, Barstow CA 92312. 619-256-2121.

FM antennas (2) on 104.3 and 97.9. B Lacy, WAVQ, 2025 N Hwy A1A, Indianalantic FL 32402. 813-773-1962.

FM - ANTENNAS

Designed and built for your frequency. Choose from 1 to 12 bays and five power levels. Financing available. Call Jimmie Joynt at S.W.R.
214-335-3425

RCA 3 twr phasing and distribution cabinets, contains several inductors, variable vacuum cap, several fixed vacuum caps; Shell type matching T units (3). N Johnson, 92 Higgins Rd, Presque Isle ME 04769. 207-764-0605.

Collins G5CPS-AE 5 bay broadband super power FM, 98.9 MHz, built by ERI on ground, exc cond. D Martin, WSLM, Salem IN. 812-863-3797.

300' 1" copper line. N Johnson, 92 Higgins Rd, Presque Isle ME 04769. 207-764-0605.

Want To Buy

Rohn 55G, need 19 10' sections, cheap and close to N Cntrl WV. E Stewart, WDCl, POB 371, Bridgeport WV 26330. 304-642-8644.

AUDIO PRODUCTION

Want To Sell

Collins 6P1, tube mic preamps (2), 50's vintage, \$95; Lexicon LXP-5, multi effects processor, \$275. D Miller, Airborne Audio Prod, 12209 W 88th St, Lenexa KS 66215. 913-492-8822.

Technics SH-9010 stereo parabolic EQ, rk mt, 2 chnl, 5 bands/chnl, adj freq/bandwidth each band +/- 12 dB/band, unbal in/out, \$225/BO + ship. E Helvey, Summit Prod, 461 Layside Dr #100, Winchester VA 22602. 703-877-2717.

CASSETTES • CARTS • REELS

J & I AUDIO/VIDEO

A wholesaler in the Radio and Television market. Now running SPECIALS on audio and video:
BASF CASSETTES-AMPEX R-Rs AUDIOPAK, FIDELIPAC & ITC CARTS

For more information call Kris Elliot at
1-800-942-1711
or write to: J&I Audio/Video
20899 Kelvin Pl.
Woodland Hills, CA 91367

Circle (115) On Reader Service Card

ITC erase/splice finder, \$600. R Statham, WSTU, 1000 Alice Ave, Stuart FL 34994. 407-692-1000.

MXR NR dbx type II, 2 chnl NR unit, \$30. G Dunn, N CA News, 5383 Willow Lake Ct, Byron CA 94514. 510-516-0299.

Looking for Audio Bargains?

We BUY ★ SELL ★ TRADE QUALITY USED EQUIPMENT
317-962-8596



UREI 535 dual graphic EQ, \$157 + shp. J Cary, WLKX, 15226 W Freeway Dr, Forest Lake MN 55025. 612-464-6796.

Demeter 4 channel rack mount tube direct box NEW \$795. W Gunn 619-320-0728

ADC 96 & 144 Pr TT patchbays, excel cond, 1 rack space, 3 rows of 48, top 2 rows normalled, \$149, 96 is 2 row normalled, \$129 (you remove old wiring) or we totally refurbish w/new front panel, ready to install, \$199-229. T f cords up to 10 per bay at \$9 ea, reg \$13.95, also 1/4" bays. Audio Village, 619-320-0728, or Fax 619-320-2454.

Want To Buy

KepeX II rack. R Eskridge, Galaxy Rcdng, 1508 Harlem Dr, Memphis TN 38114. 901-274-2726.

AUTOMATION EQUIPMENT

Want To Sell

CSI OTMF decoder, \$350; Conex 25 Hz generator, \$200; Conex 25 Hz decoder, \$100; SMC TS25 tone sensor, \$75. D Rose, KDUC, POB 250, Barstow CA 92312. 619-256-2121.

SMC DP2 brain, PD-5 clock, 352 Carousels (2), 452 Carousel, 20A switcher, time cart, stereo cart, spare parts kit, \$2000. D Rose, KDUC, POB 250, Barstow CA 92312. 619-256-2121.

SMC MSP-12 inc 2 monitors, keyboard, 452 Carousels (2), ITC mono SP carts (2), SMC 712 dual stereo play carts, equipment racks (2), excellent condition, \$6000. C Falvo, 110 Healy Ave, Clearfield PA 16830. 814-765-5541.

IGM Go-Cart 1, IGM Go-Cart 2, excellent condition, 78 trays, racks also available, \$400/ea, racks \$100 deluxe; IGM Instacart 48, rack available, \$500; Deluxe IGM rack, \$100; 350 Carousel, fair condition, \$300; R O'Kelly, KLOO, 1221 SW 15th, Corvallis OR 97339. 503-753-4493.

IGM Basic A parts & svc, several source cards, spare entire system, cables, extra memory, etc, for piece prices, R O'Kelly, KLOO, 1221 SW 15th, Corvallis OR 97339. 503-753-4493.

SMC with Otari R-R with 25 Hz (3), DP-2, FDC 5 clock, DE-20 switcher, mono PB units (2), 350-RS Carousels, \$1000/all + shp or will part out. V Richardson, WWST, 8419 Kingston PK, Knoxville TN 37919. 415-693-1020.

HALL Electronics

706 Rose Hill Drive, Charlottesville VA 22901

Here are just some of the bargains we have in stock:



- CRI FM-2 Basic FM Processing Package - Rebuilt \$ 995
- Ampro AC-10DS 10 Pot Stereo Console - As Is \$ 395
- Belar AMM-2A AM Modulation Monitor - Rebuilt \$ 795
- BE 5300B Stereo 3D w/tones - Rebuilt \$ 1,595
- Marti MW-500 STL Booster/Repeater - Rebuilt \$ 1,295
- Audicord A Series Stereo Cart Player - Rebuilt \$ 295
- ITC Premium Line Single Deck Motors - NEW \$ 95
- Otari MX-5050 1/2QXHD 1/2" 4 Track Deck Only - Rebuilt \$ 150
- Orban 622B Stereo Parametric EQ - Rebuilt \$ 395
- Valley 400 Mic Processor - Rebuilt \$ 359
- Valley 'DYNAMITE' Stereo Studio Limiter - Rebuilt \$ 195
- Belar SCM-1 SCA Monitor - Used \$ 295
- Marti RMC-20 Digital Remote Control - As Is \$ 175
- Marti r-50/450 450MHz RPU Receiver - Rebuilt \$ 495
- Harris/ERI 10KW 96.7 MHz FM Isocoupler - Used \$ 395
- West Penn #433 1000' 9 Pair Shielded Audio Cable - NEW \$ 375
- Tektronix 7704A 200 MHz Scope - Rebuilt \$ 495

Call us for the Best New & Completely Rebuilt Equipment! (804) 984-HALL (4255) Fax: (804) 984-FAXX (3299)

marantz

Portable News Package \$ 409.00
Mic, Cable, Marantz Cassette



Audix 300-xb



PMD222

The Marantz PMD222 is a portable 3-Head 2-Speed Cassette Recorder with the following features:

- XLR balanced mic input
- True tape/source monitoring
- Switchable Limiter

Econo Portable News Package \$ 349.00
Same as above but with a Marantz PMD201

LPB®



MODEL C-8S

We have a completely rebuilt & ready to ship 8 channel stereo console exactly like the one pictured above for \$ 2,195. Price includes manual & 90 day warranty.

AUTOMATION EQUIP...con't

Want To Buy

ATC AA 1051 tone generator w/manual or wiring diagram for same; IGM EC brain/ctrlr. D Moore, WALM 10980 25 1/2 Mile Rd, Albion MI 49224. 517-629-5516.

CART MACHINES

Want To Sell

Ampro mono play, gd cond, \$100; Spotmaster 1070P mono, gd cond, \$100. G Kornbluth, A&J Rec, 225 W 57th St, NY NY 10019. 212-247-4860.

Audi-Cord DL-PS stereo PB (2), \$600 ea; Audi-Cord DL-RS R/P, \$1000. B Dixon, WAWC FM, 10129 N 800 East, Syracuse IN 46567. 219-457-8181.

Great Prices on original equipment tape heads for ITC, BE, Fidelipac, Otari, Tascam & others!
(804) 984-4255



BE 2000 mono PB, need cord & motor fan, \$50 + COD. R Weaver, WBZB, 413 S Fuquay Ave, Fuquay-Varina NC 27526. 919-552-9357.

BE Spotmaster 3000 R/P, w/sec & ter tones, exc cond, \$100 + ship; BE 3000 R/P w/tones, needs adjustments, \$75 + ship; BE 4000 PB w/ftd, exc cond, \$75 + ship; BE 4000 PB, w/ftd, needs adjustments, \$50 + ship, all machines mono. S Zubrick, Z-Tec, 214-475-0234.

ITC SP stereo PB only (3), \$450. R Statham, WSTU, 1000 Alice Ave, Stuart FL 34994. 407-692-1000.

Tapecaster X-700 R/P mono w/secondary cue tone generator/detector, like new, 6 hrs running time, \$750. R Franklin, Super Sound Stud, 1004 Dekalb St, Norristown PA 19401. 215-646-7788.

Spotmaster 505 mono player, recently recond, \$300; also R/P, \$450. R Franklin, Super Sound Stud, 1004 Dekalb St, Norristown PA 19401. 215-646-7788.

ITC mono R/P (2), 1 w/time delay, VGC, \$500/ea + shp. R Statham, WSTU, 1000 Alice Ave, Stuart FL 34994. 407-692-1000.

ITC 3-D and one RP series R/P stereo, gd cond, \$1800/both. J Stitt, WCIN, 106 Glenwood Ave, Cincinnati OH 45217. 513-281-7180.

RCA R/P; Spotmaster 505 PB. N Johnson, 92 Higgins Rd, Presque Isle ME 04769. 207-764-0605.

SMC 350 Carousel cart machines (31, gd cond, \$350/ea, \$1000/all 3. A Jojo, RF Telecommunication, POB 4, South Bend IN 46624. 219-272-5144.

BE 5300C tripledeck, stereo, PB, mint less than 50 hours, BO. R Kaufman, Pams Productions, POB 462247, Garland TX 75046. 214-271-7625, after 3PM CDT.

Want To Buy

Workable cart machines; Marti remote system. M Hellinger, WYYZ, 3970 RCA Boulevard, Palm Bch Grdns FL 33410. 407-694-2525.

ITC, BE, Fidelipac cart machines: single, triple, mono, stereo, play & record/play. Call M O'Drobinak @ 619-758-0888.

CASSETTE & REEL-TO-REEL RECORDERS

STUDER SERVICE SPECIALIST

Thousands Serviced • Unbeatable Rates
Precision Capstan Resurfacing
Audio Advantage
Tel (615) 742-3834
PRICE-QUALITY-SERVICE
Let Us Prove It

Want To Sell

Ampex AG-350 w/2 trk R/P heads, Inovonics 3 spd elect, 3 spd reversible Beau motor, mdt in AG-440 console, \$700/BO + ship. E Helvey, Summit Prod, 461 Layside Dr #100, Winchester VA 22602. 703-877-2717.

Ampex/Schafer AF440 2 trk reproduce decks (2) rack mount, \$200 ea. D Bailey, Rock Shoppe Prod, 3422 Beech St, Rowlett TX 75088. 214-475-9796.

Ampex 3200 high speed R-R all tub duplicator, 1 master 4 slaves, new mono heads, new pinch rollers and guides, vgc, \$1200/BO. R David, Audio Oasis, POB 4181, Falls Church VA 22044. 800-966-2747.

Revox B77 7.5 & 15 ips, 10.5" reels, exc cond, BO; Otari MX 5050, 4 chnl rack mt, 1/4" tape, 7.5 & 15 ips, 10.5" reels, gd cond, BO; Pioneer RT1050, 1/4" 1/2 trk, 7.5 & 15 ips portable, exc cond, BO. J Phillips, Record & Play, POB 412, Tuckahoe NY 10707. 718-548-1623.

Ampex MM-1200 24 trk w/spare capstan and reel motors, spare play, record, bias, logic, servo cards and spare parts kit, 16 trk head assembly w/syncronizer w/remote, manuals, \$8000; Scully 280B-2, 260 xport w/280-B electronics, in new Russ Lang cabinets, new heads, mono to 8 trk, \$1500/BO. R David, Audio Oasis, POB 4181, Falls Church VA 22044. 800-966-2747.

Nortronics sensor head (8), \$10 ea/\$75 all. D Peluso, KJUL, 2880 E Flamingo Rd, Las Vegas NV 89121. 702-732-2200.

Otari ARS1000 (3), PB only w/25 Hz sensor, \$350. R Statham, WSTU, 1000 Alice Ave, Stuart FL 34994. 407-692-1000.

Otari SX70 8 trk, 1", like new, used 50 hrs, incl 6 1" reels, new maintenance tape, remote cntrl on custom stand 2/25 ft interface cables, BO. B Giordano, WODS, 30 Winter St, Boston MA 02108. 617-426-2200.

REVOX PARTS/SERVICE

Cassette-CD-Open reel
Rebuilt A77s, \$850.00
Capstan resurfacing, ALL BRANDS.
JM TECHNICAL ARTS
30 Music Sq. W. #156
Nashville, TN 37203 (615) 244-6892

Scully 280A (5), 1/4" 2 trk, 7.5-15, w/o Russ Lang console cab, vgc, \$500/ea; Recordex 250 R/R or cass master 5 slave high speed duplicator, \$1000. G Kornbluth, A&J Rec, 225 W 57th St, NY NY 10019. 212-247-4860.

Crown GCS X vintage 10" R-R, 2 trk. M Muderick, Muderick Rcdg, 101 Earlington, Havertown PA 19083. 610-449-6970.

Technics RS-1520 2 trk stereo, 3 spd, bal & unbal in/out, rk mt adapters, remote control, extra full trk plug in head assembly inc, \$500/BO + ship. E Helvey, Summit Prod, 461 Layside Dr #100, Winchester VA 22602. 703-877-2717.

CLEAN PATCH BAYS
NO DOWN TIME

VERTIGO BURNISHERS AND INJECTORS RESTORE ORIGINAL PERFORMANCE TO YOUR PATCH BAYS

\$34.95 Ea.

VERTIGO RECORDING SERVICES

12115 Magnolia Blvd. #116 818-907-5161
North Hollywood, CA 91607 Fax 818-784-3763

VSC C-4 Soundpacer cass rec with variable speech cntrl, AC/DC, can feed R-R deck through for editing R-R tapes at high speed, ED, \$50 + ship. E Helvey, Summit Prod, 461 Layside Dr #100, Winchester VA 22602. 703-877-2717.

Otari 5050 MK III-8 trk, heads excellent, \$2450. Wayne Gunn 619-320-0728.

Nagra 4.2 7" reels, portable case, 59.94 sync board for video, power supply & extras, \$2300/BO. L Hansen, RSVP Inc, 7701 N Teutonia Ave, Milwaukee WI 53209. 414-354-6400.

Wollensak 1520-AV mono w/built in compressor, fair cond, portable, \$50. R Franklin, Super Sound Stud, 1004 Dekalb St, Norristown PA 19401. 215-646-7788.

AKAI S1000 sampler, AKAI S900 sampler, Otari MTR-12 (2), Otari MX-70, Soundcraft TG-3000 44 Ch-88 inputs 16 TK out, w/patch bay, BO. J Burdick, DJ Int'l Records, 727 W Randolph, Chicago IL 60606. 312-559-1845.

Otari 7308 8 trk 1" recorder, low hours, excellent condition, 15/30 ips, with remote, \$3100; Tascam 32 (3) 2-track, digital, return to 0, pitch control, 7.5 & 15 ips, less than 10 hours, \$750/ea. L Wagner, Armigva Radio Network, POB 1788, Orlando FL 32802. 407-299-1299.

Revox A-77 (3), 3_7_ ips, with rack mounts, good condition, \$400/ea; Revox PR-99 (4), 7_15 ips, PB only, built-in tone sensors, good condition, \$800/ea. R O'Kelly, KLOO, 1221 SW 15th, Corvallis OR 97339. 503-753-4493.

Studer Revox 99, 2 track, low hours, excellent condition, \$1950; Technics 1500 RS, 2 track, 15, 7.5, 3 3/4 ips, Plus 1/4 track PB head, with remote, lke new/excellent condition, \$950. L Wagner, Armigva Radio Network, POB 1788, Orlando FL 32802. 407-299-1299.

16 track 2" \$3450, MCI JH110C-8 \$2800, 110C-8 play only \$500, ATR800 mono or Tascam 7300 or 2502 \$600 ea, MCI Locator III \$1195, Tascam 52 2 trk \$1200, Ampex AG350 electr \$50/ch. W Gunn 619-320-0728.

Otari Mark II-IV 1/2" 4-track, multi-track, mint, less than 50 hours, Best Offer. R Kaufman, Pams Productions, POB 462247, Garland TX 75046. 214-271-7625, after 3PM CDT.

Reconditioned & Warranted Tascam 34, Four Track: Excellent Condition, Great Production Unit, Reasonable Price. CALL Mark @ 619-758-0888.

EMPLOYMENT

To place ads in this section, use the ActionGram form. To respond to box numbers write Radio World, PO Box 1214, Falls Church, VA 22041. Attn: _____

POSITIONS WANTED

15 yr pro Christian bdcter seeks anncr/PD pos w/committed religious stn in AK or SE region Carlos, 305-754-9437.

20 yrs exp asst eng AM/FM, any format, FCC 1st class/Gen/Radar, Marine, rest, ham, SBE cert. C Hamlin, 509 W 4th St, Corbin KY 40701. 606-528-5460.

Call and hire Janet, FT announcing, programming aspirations, computer literate, in radio since 1980, PT announcing, marketing exp, metros, bedroom communities preferred. Janet, 502-895-5888.

HELP WANTED

Chief Engineer needed for Miami FM-FM duop. Must be aggressive self-starter with experience in transmitter, antenna, studio, construction, maintenance and digital recording. Come live in the sunshine and work with progressive thinkers. Women and minorities encouraged to apply. E.O.E. Send resume and references Fed Ex to:
Russ Oasis-WXDJ
3191 Coral Way, Suite 1000
Miami, Florida 33145

EXPERIENCED CHIEF ENGINEER - Experienced AM directional and FM engineer needed for one of the Midwest's finest facilities. A great place to live and work. Send resume and salary history to Radio World, POB 1214, Falls Church, VA 22041. Attn: 94-09-21-1RW. This is not just a job, it's a great career opportunity. E.O.E.

Award winning Sports Radio network seeks a top notch production director with a great ear. To oversee remote broadcasts. Send cover letter and resume with references and experience to: John McMullin, POB 2888, Daytona Beach, FL 32115.

Bilingual newscaster anncr, radio/TV, spanish neutral accent, 20+ yrs exp in US, Cntrl Amer and Europe. 305-717-6811.

Broadcasting school grad, academic credentials seeks on-air talk show, cutting commentary, incisive research, will relocate. Joe, 918-627-5611.

Combo Manager, sales, PD, CE, Anncr, prod, Tampa Bay, coastal FL or pwrful sig in gd area, 30 yrs exp. Bill, 813-844-3823

Fun, Hot talk radio, producer, writer, prod, promo, computer literate, sale, marketing. 408-427-3511.

Generation X, conservative talk host w/crazy side, hard worker, prod exp. K Marsh, 716-933-6629.

GM/GSM w/news, weather, sports play by play and all around exp, seeks oppor in TX. R Muirhead. 405-335-2343.

Diligent, dedicated on-air/prod talent, recent bdctng school grad, will travel, have intem exp and mobile DJ equip. George, 405-721-7871.

Director of Operations, 9 years experience, willing to relocate, hard-working, quick learner. P Schoolcraft, POB 291, Springerville AZ 85938. 602-333-2814.

Nat'l Rock Promo Mgr has left his label, pursuing other opportunities in AOR radio or records, exp'd AOR jock, bloodtype FM. Blake, 914-635-8285.

Recent bdctng grad with stn exp, dependable, humorous, seeks on-air pos, great news, copywriting and production, will relocate. Mark, 405-748-5905.

Apprenticeship, BSEE eager to learn bdct eng in VA or NC, licensed EIT and amateur rad op. C Horne, 919-985-2863.

Board Op/Technical Producer w/6 mos exp seeks FT/PT pos w/news/talk fmt, San Antonio/Austin TX area. T Frost, 210-654-7530.

CE/TD 25+ years domestic & intl exp, AM stereo to 150 kW, FM to 100 kW ERP, digital audio & computer literate, have exp, will travel. Bruce, 915-833-7651.

Combo Manager, sales, PD, CE, Anncr, prod, Tampa Bay, coastal FL or pwrful sig in gd area, 30 yrs exp. Bill, 813-844-3823.

Dynamic, enthusiastic, individ wants to sell, loves to sell, will make money for your OK stn. P Karlebach, 918-743-2143.

GM with 8 years experience, can do most everything incl some engr, will relocate, awesome resume. Clint, 302-477-0265.

Make a young eager, willing to travel, air talent happy, seeks AOR/CHR/Classic Rock. Brad, 405-722-2846.

Stop, Drop and grab on to the newest bdctr on the market, bright, funny, and yours for a phone call. John, 405-359-9445.

HELP WANTED

WBQB/WFVA Fredericksburg, Virginia seeks Chief Engineer. Must have minimum five years experience with AM and FM transmitters, studio equipment, computers, and FCC compliance. Stable, debt-free company offers excellent compensation/benefit package. Resume to General Manager, WBQB/WFVA, POB 269, Fredericksburg, Virginia 22404. EOE.

WYXR-Philadelphia has an opening for an Assistant Chief engineer. Experience with maintenance of audio, digital and RF equipment required. FCC General Class license or SBE certification preferred. Send resume to: WYXR, One Bala Plaza, Suite 243, Bala Cynwyd, PA 19004. Attn: Mike Guidotti. Pyramid Communications is an Equal Opportunity Employer.

Customer Service Rep: Major bdct equip mfg is looking for an individual w/good tech knowledge, good written/verbal language skills. Will administrate the in-house customer repairs & interface with customers by phone. Full employment benefits.
Resume to:
1014 Camino Real #5, Ste 367
Sunnyvale, CA 94087

Chief Engineer wanted for Benchmark Communication's Dover/Wilmington, Delaware duopoly operation. Candidate must have five years experience in AM directionals, high powered FM's, studio maintenance, audio processing, digital studio technology & computer operations. We offer a comprehensive benefit package including 401(k) & major medical. Send resume & salary requirements to Personnel, WDSO FM/WDOV AM/WSRV FM, PO Box 11727, Wilmington, DE 19850.

FULL-TIME ENGINEERING ASSISTANT
WOMX-FM in Orlando, FL has an immediate opening for a full-time Engineering Assistant. Applicant should have a minimum of two years experience in radio broadcast engineering and at least a two year Associate degree in electronics or equivalent.
Knowledge of and experience with personal computers and remote broadcasts is required. Must have good communication skills and an ability to work well with people. SBE certification a plus. Please send your resume to:
Jeff Keith, Chief Engineer
WOMX-FM
P.O. Box 8105
Winter Park, FL 32790
Nationwide Communications is an equal opportunity employer and we encourage women and minorities to apply.

HELP WANTED

WORLD-CLASS PERFORMERS PLACE QUALITY FIRST



Harris, a \$3 billion Fortune 200 Corporation, has an immediate opportunity available at its Broadcast Division's, Harris Allied Broadcast operation in Richmond, Indiana, for a salesperson inside its Richmond Broadcast Center. Harris Allied Broadcast is the world leader in the supply of state of the art Radio Studio storage and automation systems and equipment.

Leading the world in Broadcast Technology and Equipment provides us the opportunity for continued growth, and an opportunity for you to grow with us.

This demanding position requires excellent verbal and written communication and presentation skills, and the ability to meet flexible schedules. As a member of this technical sales team, you will bring to the table your knowledge of the Broadcast Industry, coupled with the ability to identify Customer's needs. In addition, the successful candidate will be well versed in all aspects of Broadcast Equipment, including Studio, RF, and Digital technology, with at least two years of experience in this market segment, interfacing with professional Broadcast Equipment Suppliers and Customers. Some travel to various equipment shows and Customer locations is required.

The Broadcast Division currently has products in over 150 countries throughout the world and growing, and we are plotting the course for advanced TV technology and Digital Radio Broadcasting in the U.S.

Harris Corporation offers a competitive starting salary, with a comprehensive benefits package and opportunities for growth and advancement. Join a world leader, and send in your resume today.

If qualified please send resume (including salary history/requirements) in confidence to: William G. Kellner, Supervisor, Human Resources, Harris Corporation, Broadcast Division Headquarters, Dept. BC, P.O. Box 4290, Quincy, IL 62305-4290.

Harris Corporation is an Equal Opportunity Employer, and we encourage women and minorities to apply. M/F/D/V



ADVERTISE
in RADIO WORLD'S
CALL 800-336-3045

Broadcast Equipment Exchange



CASSETTES/R-R...WTS

Pioneer 7" R-R stereo: Teac 310 stereo. N Johnson, 92 Higgins Rd, Presque Isle ME 04769. 207-764-0605.

Long Life MEC Tape Heads One year warranty Flat response of ±1dB 35 Hz to 16 kHz SEQUOIA ELECTRONICS (408) 363-1646 FAX (408) 363-0957

Recordex 6 cassette rewinder \$100; Tascam 404 4 trk 10" in flight case w/free dbx \$750; MRL new short test tapes \$39 for 1/4" to \$199 for 2". W Gunn 619-320-0728.

Ampex, ITC, Scully Reel-to-Reel Tape Recorder Spare Parts, Accessories Motor Remanufacturing. VIF INTERNATIONAL PO Box 1555 Mtn View CA 94042 U.S.A. Inside USA: 1-800-848-4428 Outside USA: 1-408-739-9740 FAX: 1-408-739-0809

Scully '100' recorders, record/play amplifiers, 8, 16, 24 track heads. Sequoia Electronics, 4646 Hounds-haven Way, San Jose CA 95111. 408-363-1646

Scully 260B 2 chnl, gd cond. T Tonjes, WREN, 201 W Hwy 24, Topeka KS 66608. 913-437-6549.

Want To Buy

Lang LRP-1C, manual, schematic, or any technical data; electronics for Ampex 350/351. B Glenn, KGDN, POB 3258, Tri-Cities WA 99302. 509-946-3258.

Ampex tube recorders and mixers. W Gunn, 619-320-0728.

Ampex ATR100 taperecorders for parts. Circuit cards, heads, motors, machine parts, or electronic parts. Call 818-907-5161.

Tascam 58 1/2" 8 trk wanted to buy or trade for Otari 5050 MK III-8 or...? Wayne Gunn 619-320-0728.

CD PLAYERS

Want To Sell

Studer A7s7 (2), exc cond, w/spec book, BO. B Giordano, WODS, 30 Winter St, Boston MA 02108. 617-426-2200.

COMPUTERS

Want To Buy

Tandy 6000HD w/at least 1 floppy drive. Mel Crosby, 408-363-1646, FAX 408-363-0957.

CONSOLES

Want To Sell

Ampro AC-8 mono, gd cond, \$800 or trade for stereo console. E Smith, WDFX, POB 1855, Cleveland MS 38732. 601-846-7060.

Auditronics 501 46 I/O modules, 52" main frame w/32 outputs, 400 point patchbay, gd cond w/all upgrades, \$6000/BO; Auditronics 110-8 w/12 I/O mono modules, stereo module and spare i/o module, all upgrades, Jensen xformers exc cond, \$1200/BO. R David, Audio Oasis, POB 4181, Falls Church VA 22044. 800-966-2747.

Gotham long throw faders (10), \$50 ea. G Kombluth, A&J Rec, 225 W 57th St, NY NY 10019. 212-247-4860.

MCI JH416 18x4x2 recording console w/patch bays & producers desk, updated w/5534 chips, clean w/spare faders, parts and manual. \$3000. D Bailey, Rock Shoppe Prod, 3422 Beech St, Rowlett TX 75088. 214-475-9796.

Shure M-67, rack mount for mixer. D Peluso, KJUL, 2880 E Flamingo Rd, Las Vegas NV 89121. 702-732-2200.

Sphere Eclipse C 40x24 plasma meter, Allison 65k automation with super graphic, parametric and quasi parametric EQ's, 440 point patchbay with prod desk, very good condition, \$20,000/Best Offer. R David, Audio Oasis, POB 4181, Falls Church VA 22044.800-966-2747.

Spotmaster 5M11 mono, 5 chnl, 15 input, \$175; Spotmaster 4M50 mono, 4 chnl, 8 input, mint condition with doc, \$190 + ship. S Zubrick, Z-Tec, 214-475-0234.

BE 8M150 8 chnl. N Johnson, 92 Higgins Rd, Presque Isle ME 04769. 207-764-0605.

Magnecord 1022 rack mtd. N Johnson, 92 Higgins Rd, Presque Isle ME 04769. 207-764-0605.

Gates Yard, 8 chnl mono input, dual VU meters, w/new solid state electronics not installed, \$100 + shp. G Dunn, N CA News, 5383 Willow Lake Ct, Byron CA 94514. 510-516-0299.

Harris Medallist 10. E Gross, KEYZ, 410 E 6th St, Williston ND 58801. 701-572-5371.

Kustom, 6 rotary pot, mono, solid state, nds work, \$350/BO. R O'Kelly, KLOO, 1221 SW 15th, Corvallis OR 97339. 503-753-4493.

LPB 5 chnl, \$750. R Statham, WSTU, 1000 Alice Ave, Stuart FL 34994. 407-692-1000.

Micro-Trak 6618 need svc manual. R Hansen, POB 884, Valdez AK. 907-835-5018.

Opamp Labs 2008-RS, 20 input, 8 buss & stereo out, 2 16x2 remix/cue sections, \$1500. L Wagner, Ardmigva Radio Network, POB 1788, Orlando FL 32802. 407-299-1299.

Shure M68 4 into 1 mic mixer w/lo cut filter, mint cond w/manual, \$100. A Levinson, Spruce Hill Music, 1002 S 49th St, Philadelphia PA 19143. 215-729-9041.

Shure M-67 mixer and phone w/voice coupler. B Campbell, KRIG, Bartlesville OK. 918-333-7943.

Tascam model-3 mixing boards with meter bridge, 8x4x2 cue & echo, 4 input RIAA phono inputs, 6 lo-z inputs, 2 1/4" hi-z inputs with manual & box, \$500. R Eskridge, Galaxy Recdg, 1508 Harlem Dr, Memphis TN 38114. 901-274-2726.

Tascam model-5 rcdng/mixing consoles w/meter bridge, 8x4x2, expandable, cue & echo sends, ctrl room and studio feeds, talkback, slate and tones, w/manual & box, \$750 ea/\$1300 for both. R Eskridge, Galaxy Rcdng, 1508 Harlem Dr, Memphis TN 38114. 901-274-2726.

Trident Series 70/Trimix parts, input mods, group/monitor mods, master mos, ps, frame, BO/trades accepted. R Ore, Clockwork Sound, 606 Mamaroneck Ave, Mamaroneck NY 10543. 914-381-0661.

Ramko DC5AR 5 channel mixers, vgc, \$175 each. 916-725-2434.

Want To Buy

Harris-Gates need transisterized duolux stereo board that can drive AM-FM mono combo. A Wilkerson, WLIL AM, POB 340, Lenoir City TN 37771. 615-986-7536.

McMartin any, need for parts, will pay s&h. E Smith, WDFX, POB 1855, Cleveland MS 38732. 601-846-7060.

DISCO-PRO SOUND EQUIPMENT

Want To Sell

Teac 8 chnl mixer; Fostex A-8 8 trk rec; Techniques SL1200MK2 turntable. D Rose, KDUC, POB 250, Barstow CA 92312. 619-256-2121.

Akai S1000 sampler; Akai S900 sampler (2); Otari MTR-12 (2); Otari MX-70; Soundcraft 6000, 44 chnl, 88 inputs, 16 tk out w/patch bay, BO. J Burdick, DJ Int'l Records, 727 W Randolph, Chicago IL 60606. 312-559-1845.

Ensoniq EPS sampling keyboard with 4X memory & 8 output expander, in box with manuals, software avail, \$900. D Bailey, Rock Shoppe Prod, 3422 Beech St, Rowlett TX 75088. 214-475-9796.

AKG R-25 remote ctrl, w/cable for AKG B-25 reverb unit, will trade for Teac RC-170 remote. J Roper, Imperial Sound, 383 N Studio St, Terre Haute IN 47803. 812-877-2663.

dbx 3BX parametric dynamic range exp. \$200. A Levinson, Spruce Hill Music, 1002 S 49th St, Philadelphia PA 19143. 215-729-9041.

Fostex 3180 stereo reverb w/pre-delay, will trade for UREI Cooper time cube. J Roper, Imperial Sound, 383 N Studio St, Terre Haute IN 47803. 812-877-2663.

JBL 5234A crossover, JBL 4408 studio monitor. R Eskridge, Galaxy Rcdng, 1508 Harlem Dr, Memphis TN 38114. 901-274-2726.

JBL D16R2405 replacement diaphragm, for JBL 2405 slot tweeter, will trade for pr of AKG D-141 headphones. J Roper, Imperial Sound, 383 N Studio St, Terre Haute IN 47803. 812-877-2663.

Tapco 220 graphic EQ, 2 chnl, \$150; DOD R-880 dual delay, \$100; Tapco 4400 stereo reverb w/graphic EQ, \$145; DOD r-875 stereo flange doubler, \$165. R Eskridge, Galaxy Rcdng, 1508 Harlem Dr, Memphis TN 38114. 901-274-2726

FINANCIAL SERVICES

FINANCING

LOANS BY PHONE (800) 699-FLEX

We finance all types of Broadcasting Equipment Flexible Credit Criteria Flexible Payment Plans No Down Payment, No Payments For 90-Days Available

To apply or request additional information call Jeff Wetter.

FLEX LEASE, Inc.

EQUIPMENT FINANCING ON ALL RADIO EQUIPMENT ■ Easy to qualify ■ Fixed-rate, long-term leases ■ Any new or used equipment ■ 100% financing, no down payment ■ No financials required under \$50,000 ■ Refinancing existing equipment Call Mark Wilson (800) 275-0185

LIMITERS

Want To Sell

CBS Labs Volumax 441 stereo peak cntrlr, \$100 + ship. D Kennedy, 800-377-0022.

Optimod 8000A excellent condition, 3 yrs since factory rebuild, \$1800; Moseley 505-C, 950 MHz, SN41201T not type certified, \$3000. Ron, KPIC, 1206 N Main, Beebe AR 72012. 501-882-3331.

CBS Labs Audimax RIIZ 443, tube-type, auto lvl ctrl, will trade for UREI LA-3A or Gain Brain. J Roper, Imperial Sound, 383 N Studio St, Terre Haute IN 47803. 812-877-2663.

CRJ SMC-600A. stereo mod cntrlr, \$200. B Lacy, WAVQ, 2025 N Hwy A1A, Indialantic, FL 32402. 813-773-1962.

Harris MSP-90 AM, will require external NRSC, \$200/BO. R O'Kelly, KLOO, 1221 SW 15th, Corvallis OR 97339. 503-753-4493.

Inovonics 230 mono, 8 band, rcntly calibrated, \$500. A Anello, Anello Svcs, 1915 W Waters Ave, Tampa FL 33604. 813-915-0046.

Modulation Sciences CP 803 composite processor, factory warranty, \$1000. R Feindel, WWGP, PO Drawer 3457, Snaford NC 27331. 919-775-3525.

Orben 9000A Optimod. N Johnson, 92 Higgins Rd, Presque Isle ME 04769. 207-764-0605.

Want To Buy

CBS Volumax 411 svc manual. R Hansen, POB 884, Valdez AK. 907-835-5018.

Orben 8100A/XT2 w/manuals, updates. M Skinner, 210 N 1000 East, St George UT 84770. 801-628-1000.

Fairchild 670 or 660 tube compressor/limiter, Teletronics LA-2A tube compressor/limiter or UREI LA-3A solid state compressor/limiter, call after 3PM CST. 214-271-7625.

MICROPHONES

Want To Sell

RCA Jr velocity, compleety restored, \$275; Beyer MC 740, large dia condenser, \$750. D Miller, Airborne Audio Prod, 12209 W 88th ST, Lenexa KS 66215. 913-492-8822.

Shure SM-7 inint condition, in box, \$190. S Zubrick, Z-Tec, 214-475-0234.

RCA 77-DX vintage mic, excellent condition, orig 6' cable. B Lacy, WAVQ, 2025 N Hwy A1A, Indialantic, FL 32402. 813-773-1962.

Manley Labs CR3A, new, \$795 with hockmount, windscreen & case, no risk trial in your studio. Also have used mics & everything else. Get our catalog! Liberal trade policy too. Audio Village, 619-320-0728.

COLES LIP MIKE Quality Voices in NOISY places Read the RW review or Visit booth 2025 at World Media Expo in LA and call AEA 800-798-9127

Want To Buy

Shure SM-7. D Miller, WINA, POB 498, Charlottesville VA 22902. 804-977-3030.

Shure SM-7 or EV RE-20, exc cond pret, 15-20 ft cable, must be complete. C Hamlin, 509 W 4th St, Corbin KY 40701. 606-523-0901.

CBS/NBC call letter place for RCA 44. M Harrington, POB 7619, Little Rock AR 72217. 501-223-9056.

77-DX's, 44-BX's, WE KU-3A's On-Air lights, recording lights & audition lights. Top price paid. Fast response. Bill Bryant Mgmt, 2601 Hillsboro Rd, G12, Nashville TN 37212. 615-269-6131, FAX: 615-292-3434.

Neumann U87s, KM84s, AKG 451s, EV RE20s, Sennheiser 421s. W Gunn 619-320-0728.

RCA 77DXs/44BXs ribbon, chrome/TV grey, good condition, BO. R Kaufman, Pams Productions, POB 462247, Garland TX 75046. 214-271-7625, after 3PM CDT.

MISCELLANEOUS

Want To Sell

ACD/UTC audio transformers, lg quan, \$12 ea. For list: G Kombluth, A&J Rec, 225 W 57th St, NY NY 10019. 212-247-4860.

Temperature Sensor, Solid State dual output, set lower & upper lim its. BATCO, 6920 Woodway Dr, Waco, TX 76712. 817-776-0143.

Alertlite 3-V on-air warning light, verticle, visible on 3 sides, new, \$40. R Franklin, Super Sound Stud, 1004 Dekalb St, Norristown PA 19401. 215-646-7788.

PHONE: 703-998-7600 FAX: 703-998-2966



Call Simone Mullins, Classified Ad Manager, to reserve space in the next issue. Use your credit card to pay, we now accept VISA and MASTERCARD.

RadioWorld

5827 Columbia Pike, 3rd Floor Falls Church, VA 22041

Select from these categories for best ad positioning:

- Acoustics Amplifiers Antennas & Towers & Cables Audio Production (Other) Brokers Business Opportunities Cart Machines Cassette & R-R Recorders CD Players Computers Consoles Disco-Pro Sound Equip. Financial Services Leasing Limiters Microphones Miscellaneous Monitors Receivers & Transceivers Remote & Microwave Equip. Satellite Equipment Software Stations Stereo Generators Tapes, Carts & Reels Tax Deductable Equipment Test Equipment Transmitter/Exciters Tubes Turntables Positions Wanted Help Wanted

Classified Advertising Rates Effective January 1, 1994

Table with 4 columns: Ad Type, 1x, 3x, 6x, 12x. Rows include 1-9 col inch (per inch), 10-19 col inch (per inch), Distributor Directory, Professional Card, Classified Line Ad, Blind Box Ad.

To compute ad costs: Multiply the number of ad inches (columns x inches) by the desired rate schedule for your per unit cost. Example: a 3" ad at the 1x rate is \$180, at the 3x rate \$174, at the 6x rate \$162, at the 12x rate \$147, etc.

DISTRIBUTOR DIRECTORY

The following distributors serving the broadcast industry would be glad to help you with any of your requirements.

... Blaine to Key Largo, Imperial Beach to Madawaska, Waihalla to Brownsville... RADIO! The beat goes on! CROUSE-KIMZEY OF ANNAPOLIS tops in broadcast equipment 1-800-955-6800 ask for Kathleen

CORNELL-DUBILIER MICA CAPACITORS FROM STOCK JENNINGS VACUUM CAPACITORS FROM STOCK JENNINGS VACUUM RELAYS SURCOM ASSOCIATES 2215 Faraday Ave., Suite A Carlsbad, California 92008 (619) 438-4420 Fax: (619) 438-4759

MISCELLANEOUS...WTS

Astron power supply RS-35A, 13.8 VDC 10 amps, great condition, \$50 + ship. S Zubrick, Z-Tec, 214-475-0234.

Circuit brkrs, remote resetable, 30 A, 60 A, 135 A, 220 A, all adjustable. B Wolf, 2212 NW 119 St, Oklahoma City OK. 405-755-6603.

AUDIO TRANSFORMERS... LOW DISTORTION - $2\% THD @ 30 Hz$... BROAD FREQUENCY RESPONSE... MAGNETIC SHIELDING... VARIOUS MECHANICAL CONFIGURATIONS... 60 TYPES STOCKED FOR DELIVERY... FREE CATALOG OF AUDIO ACCESSORIES... USA & CANADA ORDERS (800) 634-3457... FAX ORDERS (800) 551-2749... ESCOM, INC. 2100 WARDEN... HENDERSON, NV 89015 USA... TECH LINE: (702) 565-3993 M-Th 8 am to 4 pm (PST)

Circle (207) On Reader Service Card

Onan 6.5 kW gas, pull start, 15 hp Briggs & Stratton engine, low hours R David, Audio Oasis, POB 4181, Falls Church VA 22044. 800-966-2747.

AUDIO TRANSFORMER MAGIC... 9K-600-6... **audisar**... P.O. Box 1561, Bellevue, WA 98009... 206-454-2040

Lil Miss Moffat 48 V phantom power supply (2), \$18/ea, Paradyne 4951-03 equip rack, black, blank covers, \$175; Soundalier equip rack, \$120, all prices + shipping. B Lord, Lord Bldg, 13313 SE 208th, Kent WA 98042. 206-631-2374

Orban 9100B new complete manual w/prints, \$20 R Weaver, WBZB, 413 S Fuquay Ave, Fuquay-Varina NC 27526. 919-552-9357.

Sparta Electronics audio/RF tech manuals. D Peluso, KJUL, 2880 E Flamingo Rd, Las Vegas NV 89121. 702-732-2200

Patchbay, 24 hole w/xmas trees, many parts, BO. J Phillips, Record & Play, POB 412, Tuckahoe NY 10707. 718-548-1623.

Radio Shack 42-2110 31 input switch (3), \$5/ea. G Dunn, N CA News, 5383 Willow Lake Ct, Byron CA 94514. 510-516-0299.

NEVER BEEN USED! Brand new equipment! Burk ARC-16 remote control W/DSU & I/O connector set... \$2200. WP 470-1 band pass cavity for RPU (450MHz) band comes with 5 pg 2B coax cables-\$50 AMM-3 AM modulation monitor - \$1100. Also USED McMartin B-502 stereo console... good condition - \$800. Call 817-696-3387

Audio transformers, for list: D Peluso, KJUL, 2880 E Flamingo Rd, Las Vegas NV 89121. 702-732-2200.

Want To Buy

Jazz record collections, 10" LP/12" LP be-bop, swing, dixie, highest prices paid. B Rose, Program Recdgs, 228 East 10th, Nyny 10003. 212-674-3060.

MONITORS

Want To Sell

RCA TM-21 need flyback and pwr xfmr. Jay, NBC, 30 Rock Pl, New York NY. 212-664-3033.

McMartin TBM 1005D FM rebroadcast receiver, new, for rebroadcasting, simulcasting, translators or monitoring of RF, modulation, or injection. ALSO: (used) AM/FM modulation monitors, Buy or Sell, Repair & Calibrate McMartin, Belar. Call Goodrich Ent Inc., 11435 Manderson St., Omaha, NE 68164. 402-493-1886 fax 402-493-6821

RECEIVERS & TRANSCEIVERS

Want To Sell

JVC FM-330 AM/FM computer controlled tuner w/quartz lock, LCD multi-mode display, up to 16 preselexts, VGC, \$100/BO + ship. E Helvey, Summit Prod, 461 Layside Dr #100, Winchester VA 22602. 703-877-2717.

SCA RECEIVERS—ALL TYPES

Reading Service / Ethnic / Data Professional / Table Will work to meet your receiver needs

DAYTON INDUSTRIAL CORP. (Manufacturer) 2237 Industrial Boulevard Sarasota, FL 34234 Tel: 813 351 44545 FAX: 6081

Tempo One SSB/AM/CW transceiver, 240 W, PA section needs work, \$80 + ship; Johnson Viking Pacemaker xmr, SSB/AM/CW, needs work. S Zubrick, Z-Tec, 214-475-0234.

GE Superadio III, custom modified w/noise free SCA w/improved selectivity & sensitivity, \$95. Other modifications avail. Performance guaranteed. 800-944-0630

Sansul TU-DPP AM stereo, FM stereo tuner, C-QUAM AM stereo, \$200. G Dunn, N CA News, 5383 Willow Lake Ct, Byron CA 94514. 510-516-0299.

AM STEREO RECEIVERS From \$34.95 Portable, Home, Auto **RRADCO** Phone/FAX 708-513-1386

REMOTE & MICROWAVE EQUIPMENT

Want To Sell

Burk TC-8 w/relay interface panel, \$900. K Bass, KBIM, POB 2308, Roswell NM 88202. 505-623-9100.

Symetrix 108 broadcast telephone system, J Harvill, KSSN, POB 96, Little Rock AR 72203. 501-227-9696.

Rust 2400 remote control unit. N Johnson, 92 Higgins Rd, Presque Isle ME 04769. 207-764-0605.

RENT IT HERE! Call Steve Kirsch for Details... COMREX 1, 2 & 3-Line Extenders Switched 55/ISDN Systems... TELOS Zephyr Digital Phone Hybrids... GENTNER EFT-3100 3-Line Extenders... SHURE RP-410 Automatic Mixers... REMOTE AUDIO PACKAGES... SILVER LAKE AUDIO • 516-623-6114 • FAX: 516-377-4423

Microtran coupler coils, made for telephone co equip, PC board mount, great EQ, \$15 ea. R Weaver, WBZB, 413 S Fuquay Ave, Fuquay-Varina NC 27526. 919-552-9357.

Switched 56 Blowout! Integrated Network Corp CSU/DSU Just add a codec and v.35 cable for digital audio Xmission Single rack mount unit \$295 Dual units in same rack \$495 Digitronics P.O. Box 37833 Tempe, AZ 85285 602-841-5051

Wescom 751 G used for long distance carriers, 2 wire to 4 wire term sets, great talk show interface with plug-in pads, \$125 + COD. R Weaver, WBZB, 413 S Fuquay Ave, Fuquay-Varina NC 27526. 919-552-9357.

RENTALS RENTALS RENTALS

COMREX 3-line extender Frank Grundstein 610-642-0978 Audio/Video Consultants

QEI Catlink digital remt syst with all audio interfaces, nds fax repair, \$5000/BO. D Schmidt, Midatlantic Radio, POB 11502, Wilmington DE 19850. 302-323-0338.

Want To Buy

Gates RDC-10AC remt w/manual, all pls wkg. A Wilkerson, WLIL AM, POB 340, Lenoir City TN 37771. 615-986-7536.

SATELLITE EQUIPMENT

Want To Sell

Andrew ESA-5-4HP 4.5 meter rec only dish antenna with heavy duty tripod mount, you pick up, \$1000/Best Offer. D Woodworth, WMBI, 820 N LaSalle Blvd, Chicago IL 60610. 312-329-4433.

Ariel Proven in more than 150 Installations! The world's most capable Digital Satellite receiver at an affordable price! Compare before you buy! All Westwood One Formats! Zephyrus for JSA Zephyrus 700 SPCP We Repair & Rebuild all Popular Receivers Quick Service! Satellite Systems (719) 634-6319

California Amplifier 65 degree LNA, \$50+ ship. J Cary, WLKX, 15226 W Freeway Dr, Forest Lake MN 55025. 612-464-6796.

OuterSpace Experts! We SELL *TRADE *BUY SATELLITE EQUIPMENT 317-962-8596 HARRIS ALLIED

Scientific Atlanta AD-7550, including AD-6305 down converter, tuneable converter, 7010 demod, \$1900/BO. S Comer, KLAQ, 101 E Main St, Denison TX 75020. 903-595-2631.

6' Aluminum satellite dish, Best Offer. G Morris, WKUN, 702 E Spring St, Monroe GA 30855. 404-267-6558.

art 384 receiver 15 kHz card P Bailion, KMCM, 1218 Pioneer Bldg, St Paul MN 55101. 612-222-5555.

Wegener 1601 with cards for receiving Unistar Country, \$2000/BO. Call G Perry, 915-550-0558.

Want To Buy

SCPC receiver capable of selecting different transponder & SCPC frequency. J Varoujean, KHVH, 345 Queen St, Honolulu HI 96813. 808-531-4602.

SOFTWARE/DATABASES

Want To Sell!

PC SOFTWARE for Broadcasters. Traffic, Billing, & Accounting. Powerful, inexpensive. Works with automated, satellite or live operations. INTERFACES with popular DIGITAL AUTOMATION SYSTEMS. Try it for 90 days, no obligation. Absolute Broadcast Automation Naples, Florida (813) 643-3689

Datacount's DART traffic system software and updates, \$100. D Miller, WINA, POB 498, Charlottesville VA 22902. 804-977-3030.

U.S. RADIO STATION DATABASE: stand-alone program containing 11,825+ stations. Many searches, prints mailing labels. MAC/IBM (specify disk size). Visa/MC \$99.95/yr. (+quarterly updates): 1-800-626-2360 ext. 300 BBH Software, Inc.

Circle (156) On Reader Service Card

STATIONS

Want To Sell

In a city w/casino's, FT 1000 W AM, has served mkt for nearly 50 yrs; also FT AM 60 mi S of Jackson, MS. Paul or Linda only, 601-631-0014.

Regional Clear Chnl 1 Kw AM facility in central GA, built in 1989 with M Century CD automation, self contained, terms poss. D Helmreich, 706-743-3410.

SERVICES

REMOTE EQUIPMENT RENTALS COMREX and GENTNER 1, 2 & 3-Line Extender Systems Now With The New TELOS ZEPHYR MARTI VHF/UHF RPU Systems ISDN & Switched-56 Systems Call or FAX Dwight Weller WELLER AUDIO-VISUAL ENGINEERING Baltimore, Maryland Phone: (410 or 800) 252-8351 FAX: (410) 252-4261

LOCATION SERVICES IN THE UNITED KINGDOM Planning remotes from the U.K.? we provide a comprehensive service... we organize venues for your shows... we provide temporary equipment... live links via ISDN/Switched 56... experienced radio engineers... we help you line-up guests... Contact London (44) 81 442 8900 Good Morning from Great Britain Wired for Sound Ltd., London N15

OBSTRUCTION LIGHTING Beacons lights accessories FAX inquiries on your letterhead to ROHN P.O. Box 2000 Peoria, Illinois 61656 PH: (309) 697-4400 FAX: (309) 697-5612

- Propagation Services
- FM Studies
- Population Studies
- FCC/FAA Databases
- PC Software

Communications Data Services, Inc. 800-441-0034 703-534-0034 fax 703-534-7884 6105-E Arlington Blvd. Falls Church, VA 22044

Tower Sales & Erection Turnkey Site Development Installation & Maintenance ALL -M Broadcast, TV Microwave Systems, Antennas & Towers TOWERCOMM Communications Specialists Ben Wall President 6017 Triangle Dr Raleigh, NC 27613 (919) 881-3496 Fax (919) 881-6949

PC - SOFTWARE AM FM TV Search Programs Contour Mapping-STL Paths RF HAZ-1990 POP Count FAA Tower-Draw Tower Doug Vernier Broadcast Consultant 1600 Picturesque Dr Cedar Falls, IA 50613 800-743-DOUG

MLJ Moffet, Larson & Johnson, Inc. Consulting Telecommunications Engineers Two Skyline Place, Suite 800 5203 Leesburg Pike Falls Church VA 22041 (703) 824-5660 FAX: 703-824-5672 Member AFCC

Where In The World Are You? Reach radio professionals worldwide by advertising in Radio World's international edition. Call Simone for more information. 1-800-336-3045

EVANS ASSOCIATES Consulting Communications Engineers TV • FM • AM • ITFS • Satellite FCC Applications, Design and Field Engineering Video/Data/Voice • Light Fiber & Microwave • Wide-Area Networks & STL's 210 S. Main Street Thiensville, WI 53092 (414) 242-6000 • FAX (414) 242-6045 Member AFCC

MULLANEY ENGINEERING, INC. Consulting Engineers •Design & Optimization of AM Directional Arrays •Analysis for New Allocation, Site Relocation, And Upgrades AM-FM TV LPTV Wireless Cable (MDS/MMDS/ITFS/OFS) •Environmental Radiation Analysis •Field Work •Expert Testimony 9049 Shady Grove Court Gaithersburg, MD 20877 Phone: (301) 921-0115 Fax: (301) 590-9757

Consulting Communications Engineers • FCC Data Bases • FCC Applications and Field Engineering • Frequency Searches and Coordination • AM-FM-CATV-ITFS-LPTV OWL ENGINEERING, INC. 1306 W. County Road. F. St. Paul, MN 55112 (612) 631-1338 "Member AFCC"

W. LEE SIMMONS & ASSOC., INC. BROADCAST TELECOMMUNICATIONS CONSULTANTS 5 Gracefield Road Hilton Head Is., SC 29928 1-800-277-5417 803-785-4445 FAX: 803-842-3371

North America RF & Audio Mirkwood Engineering Services Broadcast and Telecommunications Consultants Multidiscipline Engineering and Planning Firm including • Application & Allocation Services • Project, Engineering, & Construction Management • Site Acquisition • Rural & Remote Site Installations • Field Service • Studio Design & Installation 50 Park Ave. Claremont, NH 03743 (603) 542-6784

T. Z. Sawyer Technical Consultants AM-FM-TV-LPTV • FCC Applications & Exhibits • Frequency Studies • Experimental Authorizations • Class Upgrades • AM Directional Antennas • LPTV Applications • High Power Antenna Arrays • Station Inspections • Site Selection Assistance • STL Applications • Antenna Measurements • LMA/Duopoly Studies 1-800-255-2632 FAX: (301) 913-5799 • 6204 Highland Dr. • Chevy Chase, MD 20815

STATIONS...WTS

Person to lease/purchase FM stn, small FL beach town, payments as low as \$4000/mo. Bob, WAVQ, 2025 N Hwy A/A, Indian River FL 32902. 813-896-0045.

New 50,000 watt FM Radio Station with signal reaching from Charleston, S.C. to the lower strand of Myrtle Beach. Fully automated. Includes tower, equipment, & 6.6 acres of land. \$875,000 with terms.
803-257-4989

I'm Retiring. Your golden opply. Boom growth area 21 new plants soon. 1 kW fulltime non-directional in the 50th mkt. S.E. automated. \$250K. 205-424-8544.

Want To Buy

Small successful radio station with 100 mile radius of Gainesville, FL. Fax details to 904-372-7476, or write, POB 43134, Gainesville FL 32604.

STEREO GENERATORS

Want To Sell

Broadcast Electronics FS-30 FM stereo generator, \$1250 + shpg. J Cary, WLKX, 15226 W Freeway Dr, Forest Lake MN 55025. 612-464-6796.

TAPES/CARTS/REELS & CD's

Want To Sell

A&D Cart Rebuilding
Do Bad Carts Have Your Temperature Rising?
Let A&D clean, load & pack your carts. They'll be serviced within 10 working days! *Guaranteed!*
3706 Vold Ct. 715-835-7347
Eau Claire WI 54701 Fax: 715-835-1151

7" empty reels (120) in clean white boxes, \$.35 ea, \$10/carton (40), \$25/3 cartons + shipping. E Helvey, Summit Productions, 461 Layside Dr #100, Winchester VA 22602. 703-877-2717.

ITC II-AA carts, 40 sec (9), \$3.50 ea, 70 sec (129), \$3.50 ea, 2.5 min (8), \$3.50 ea, 6.5 & 7.5 min carts (26), \$4.50 ea; 140 ct wooden cart rack, \$100. B Dixon, WAWC FM, 10129 N 800 East, Syracuse IN 46567. 219-457-8181.

Maxell LNE-25-1 low noise pro rec tape, 2400', on 7" reels, with leaders, new, sealed in plastic, \$80. R Franklin, Super Sound Stud, 1004 Dekalb St, Norristown PA 19401. 215-646-7788.

Music on 3M Scotchcarts (1000's), various lengths, \$1/cart + ship, 100 cart min. F Sobol, Westar Bdctg, 215 4th St, Eureka CA 95501. 707-445-8104.

MARATHON PRODUCTS COMPANY

Audio Cartridge Rebuilding Division

Rebuilding/reloading, like new, all brands, any length up to & including 3.5 minutes, \$1.95 ea. FOB out plant, 48 hrs delivery. (New rate effective 9/1/93)

New NAB Marathon cartridges prices on request.

35 Years professional experience!
Lifetime member AES R.D. MYERS Sr. Manufacturers of Audio Devices, Continuous Tape Mag.

69 Sandersdale Rd. Charlton, MA 01507
1-508-248-3157 or 1-508-853-0988

Circle (133) On Reader Service Card

Pams Jingles ref tapes, 1951-1976, BO. R Kaufman, Pams Prods, POB 462247, Garland TX 75046. 214-271-7625.

AC CD Library, complete, new, \$2000. L James, KDLE, 400 N Woodlawn, #201, Wichita KS 67208. 316-684-3699.

Audiopak AA-4 many new carts of various length; AA-3 & A-2 used; cart rewinder with lube tape, some new Scotchcart carts, Best Offer/everything. J Phillips, Record & Play, POB 412, Tuckahoe NY 10707. 718-548-1623.

10.5" automation reels, @700 reels w/ AC, Gold and Top 40, \$2.25/reel or BO. J Egloff, VVCI, 5528 Rapid Run Pike, Cincinnati OH 45238. 513-922-7049.

C-90, duplications overrun, new, 1st quality, 1000 or more, 20¢/ea, 500 or more, 25¢/ea. L Wagner, Ardmigva Radio Network, POB 1788, Orlando FL 32802. 407-299-1299.

Oldies fmt recorded on Scotchcart II's w/over 3200 hits from the 50's - 80's, used 6 mos, \$8250, Scotchcart II's, 320 3.5 min, \$1.90 ea used 6 mos. B Lord, Lord Bdctg, 13313 SE 208th, Kent WA 98042. 206-631-2374.

Want To Buy

TM Programming 10.5" reels, stereo rock format, w/reel dates prior to 1984. J Egloff, VVCI, 5528 Rapid Run Pike, Cincinnati OH 45238. 513-922-7049.

16" radio transcripts from 40's, list shows. R Myers, R Myers Prod, 222 Lakeview Ave, #216, W Palm Bch FL 33401. 407-832-4607.

Fidelipac/Audiopak Mastercart II gold or AA-4 light blue in 2:30 through 4:00 lengths, must be in vgc, call after 3PM CST. 214-271-7625.

TAX DEDUCTIBLE

Want To Sell

Church needs mics, stands, spkrs, mixers, recording equip & synthesizers, receipts avail. J West, 305 Al Dr, Belgrade MT 59714. 406-388-3337.

Church stn lost 5 kW xmtr, metering, monitoring, equip to fire, to arrange donations: M Dunn, WZAO, POB 27, Glen Dale WV 26038. 304-843-1210.

Community stn seeks any FM bdct equip, will provide tax deductible letter & shp/hndlg costs. G Weeks, Sylum Education Found'n, 485 NE 160 Terr, N Miami Beach FL 33162. 305-945-9464.

Radio reading service for the blind needs all types of music, books on tape for children & adults, receipts provided. J Hayes, KSAP, 1101 NW 43 Pl, Des Moines IA 50313. 800-241-9570.

Christian ntwk nels equip & sps, all types. Word of Light Network, POB 80890, Fairbanks AK 99708. 907-479-0751.

TEST EQUIPMENT

Want To Sell

Gaton mod monitor inc freq mon, GTM881 and subcarrier mon w/manuals, \$400 + you ship. Ron, KPIC, 1206 N Main, Beebe AR 72012. 501-882-3331.

Hallcrafters decade capacitor box .0001 to 1 MF, \$35. R Weaver, WBZB, 413 S Fuquay Ave, Fuquay-Varina NC 27526. 919-552-9357.

Tektronix 2337 100 MHz oscilloscope w/DVM, dual-trace, \$1400/BO + shp. V Richardson, WWST, 8419 Kingston PK, Knoxville TN 37919. 415-693-1020.

HP 334A automatic distortion analyzer w/HP 652A test oscillator, \$500/pr + shp; EICO 378 audio gen, \$50 + shp. J Cary, WLKX, 15226 W Freeway Dr, Forest Lake MN 55025. 612-464-6796.

Potomac AM-19 3 twr phase monitor; Potomac RMP-19 remote meter panel; TFT 713 freq/mod monitor; TFT EBS tone generator; RCA WX-2D field strength monitor; Kahn Research SP58-1A Symetra-Peak; Delta OIB-1 bridge w/amp. N Johnson, 92 Higgins Rd, Presque Isle ME 04769. 207-764-0605.

Precision Aparatus sweep gen, VGC, \$75; Heathkit linearity pln gen LT-1, VGC, \$40. R Myers, R Myers Prod, 222 Lakeview Ave, #216, W Palm Bch FL 33401. 407-832-4607.

Want To Buy

Potomac Instruments FIM 41 field intensity meter. C Scott, WKYU, W KY Univ, Bowling Green KY 42101. 502-745-3834.

TRANSMITTERS

Want To Sell

BE FX-50 still in box, \$5800. D Magnum, Magnum Radio, 1021 N Superior Ave, Tomah WI 54660. 800-736-WBOG.

RCA BTA 1 R AM on 1250, on air, \$1000 you pick up. KTFC, RFD 2, Sioux City IA 51106. 712-252-4621.

TTC (2) 10 W dual output FM xlators, \$2500 & \$2000; Tepco 10 W single output xlators (2), \$850 ea. J Goodale, KHRR, 2919 E Broadway, Tucson AZ 85716. 602-322-6888.

Collins 20 V gd cond. D Moore, WALM, 10980 25 1/2 Mile Rd, Albion MI 49224. 517-629-5516.

For the ABSOLUTE LOWEST PRICES on any size FM transmitters made in the U.S.A.
Call Bill Hoffman for details at **518-743-1601**

CSI EX-20-F FM exciter, tuned to your freq, \$1600; Orban 424 stereo compressor/limiter, needs 1 meter, \$300. M Holderfield, 2518 Columbia Hwy, Dothan AL 36303. 205-792-1149.

GCR-201
25, 40 & 80 Amps, 17,000 Volts

Features:
1. Lowest priced RF contactor in the world.
2. Large microswitches; powerful solenoids.
3. 50% less moving parts than competition.

GELECO:
Ph: (416) 421-5631
Fax: (416) 421-3880

RCA BC-5 & BC1-T 5 kw AM and 1 kW AM, incl manuals & some parts, also phasor components, \$3000/both you pick up. J Stitt, WCIN, 106 Glenwood Ave, Cincinnati OH 45217. 513-281-7180.

BEXT
Great new or demoed FM transmitters, exciters, amps and STL's, some at discount prices
USA 619-239-8462
FAX: 619-239-8474

Cunningham 50 50 W AM tube type, exc cond, \$500 + s/h; Cunningham RF powerline coupler for C-C op, \$25 inclds doc. S Zubrick, Z-Tec, 214-475-0234.

New 1 kW FM transmitter with stereo, \$7900. Call Bill Hoffman for details. 518-743-1601.

RCA BT-1D, will donate to high school/college B DiMeleo, KJUL, 2880 E Flamingo Rd, Las Vegas NV 89121 702-732-2200.

Cunningham 50 AM in new cond, on 1620, outdoor box, accessories, \$1500. A Anello, Anello Svcs, 1915 W Waters Ave, Tampa FL 33604. 813-915-0046.

FM - TRANSMITTERS

Factory new not used. Why buy a used transmitter when you can own a new FM Transmitter for about the same cost? Call JIMMIE JOYNT at 214-335-3425.

Gates 250 GY, 250 W AM, good condition, \$1000, Gates FM1-C, 1000 W FM, \$1000. T Tonjes, WREN, 201 W Hwy 24, Topeka KS 66608. 913-437-6549.

NEW McMARTIN BF-5K
Lowest priced tube replacements

5500 W FM, broadband grounded grid output circuit, VSWR protection, excellent efficiency 75-80% automatic recycling & overload status. Fully remote controlled. FCC approved to 5500 watts.

Goodrich Enterprises, Inc.
11435 Manderson Street
Omaha, NE 68164
402-493-1886
FAX: 402-493-6821

RCA BTA-ST & BTA-1R1 5 kW & 1 kW AM transmitters, pick up only, \$1500/ea. J Stitt, WCIN, 106 Glenwood Ave, Cincinnati OH 45217. 513-281-7180.

RCA BTA-5M. N Johnson, 92 Higgins Rd, Presque Isle ME 04769. 207-764-0605.

Spare parts for CCA AM50,000D, incl HV xtrmr, mod xtrmr, mod reactor, HV filter choke, tube skts and more. Call Transcom Corp. 800-441-8454 or 215-884-0888.

TRANSCOM CORP.

Serving the Broadcast Industry Since 1978

Fine Used AM & FM Transmitters and Also New Equipment

For the best deals on Celwave products, Andrew cable and Shively antennas.

300 watt FM	1989 TTC 300J	1 kW AM	1980 Continental 314R-1
1 kW FM	1978 Collins 831C2	1 kW AM	1974 Harris BC1H1
1 kW FM	1975 RCA BTF 1E2	5 kW AM	1979 Continental 315F
3 kW FM	1980 CSI 3000E	5 kW AM	1977 RCA BTA 5L
3 kW FM	1974 Harris FM3H	10 kW AM	1983 Harris BC10H
5 kW FM	196? Gates FM5B	10 kW AM	1971 Harris BC10H
10 kW FM	1968 RCA BTF 10D		
20 kW FM	1976 Harris FM25H/K		
25 kW FM	1984 Harris FM25K		

50kW AM 1977 Harris MW50B with spare parts

1077 Rydal Road #101
Rydal PA 19046

800-441-8454 • 215-884-0888 • FAX No. 215-884-0738

Circle (16) On Reader Service Card

Don't Miss the Two Best Selling FM Transmitters in America at WME Booth 2733

The Legend Series

100% Solid State
Many exclusive features
Built-in Redundancy
Powers to 11kW



LOW POWER SOLID STATE ON DISPLAY, TOO!

The ECO Series

Single Tube - feature packed
Economically priced
Powers to 11kW

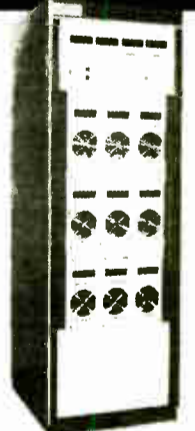

"The Transmitter People"



Energy-Onix

518-828-1690

FAX: 518-828-8476

752 Warren Street, Hudson NY 12534

Circle (108) On Reader Service Card

TRANSMITTERS...WTS

TRANSMITTERS - TV/FM/AM, new and used. Tubes, transmitter parts. 305-757-9207.

Want To Buy

LPB TCU-30 or T-8 coupler unit. J Arnold, KVVN, 1124 Foster Road, Napa CA 94558. 707-252-1440.

2-5 kW, gd cond as tax-deductible donation or reasonable price. B Ruddle, WLNL, 3134 Lake Rd, Horseheads NY 14845. 607-737-9208.

5 kW FM, less than 10 yrs old, must be in gd cond. C Donnelly, KLMJ, 1509 4th St NE, Hampton IA 50441. 515-456-5656.

FM exciter, freq agile, 20 W or better, comp. need not be wking. R Hansen, POB 884, Valdez AK. 907-835-5018.

McMartin AM/FM xmtr, any model, exciter or stereo modules. Goodrich Ent., 11435 Manderson, Omaha NE 68164. 402-493-1886.

TUBES

Want To Sell

REBUILT ELECTRON TUBES

Partial List: 6623, 23791, TH150, 6425F, 5604, 6696, 6697, 5681, 5682, 5671, 7804, 3CX10,000H3, 3CX20,000H3, 4CX5000A, 4CX35,000C

Worn out power tubes purchased

Vacuum Tube Industries, Inc.

1-800-528-5014 508-584-4500 X75

4CX250B, 4-400, 833, 813, 5CX1500, 4-1000, all types, full warranty EIMAC, Amperex, RCA. Westgate 800-213-4563.

ECONCO

Quality Rebuilt Tubes

Approximately 1/2 the Cost of New

Call for Our Price List

800-532-6626 916-662-7553

FAX 916-666-7760

Circle (131) On Reader Service Card



Quality Power Tubes

- 3CX15,000A7 4CX1500A
3CX10,000A7 4CX350A
3CX3000A7 4CX350AC
3CX2500F7 4CX250B
3CX2500F3 4CX250BC
3CX2500A3 4CX250R
3CX2500H3 4X150A
YC130 5CX1500A
4CX15,000A 5CX1500B
4CX10,000D 811A
4CX5000A 813
4CX5000R 833A
4CX3500A 8560AS

- Watch this list grow.
Manufactured in Russia's largest power tube factory.
Generous warranty based on high quality.
Honest prices based on quality at low cost.
Shipment from USA stock.

Broadcasters

Call: 205-882-1344 FAX: 205-880-8077

OEMs, Distributors, Volume Purchasers

Call: 415-233-0429 FAX: 415-233-0439

Circle (3) On Reader Service Card



Lowest Price on Tubes including:

- 4-1000A/3-1000Z/8877/4CX250B/833A
4-500/5-500/4-400/4CX 3500/5CX1500
and much more!

Factory Warranty!

1-800-881-2374 (904) 688-2374

Se habla Español FAX: (904) 683-9595

Want To Buy

RIAA phono preamp, RCA inputs, -10 dB, RCA outputs, \$20; Sony SQD2050 4 channel disc decoder, all formats, \$25. G Dunn, N CA News, 5383 Willow Lake Ct, Byron CA 94514. 510-516-0299.

TRANSMITTERS

Want To Sell

PETER DAHL CO.

Save \$\$

Heavy Duty Replacement Transformers, DC Filter chokes and capacitors for AM & FM transmitters manufactured by: AEL, CCA, CSI, COLLINS, CONTEL, CONTINENTAL, BAUER, GATES, GE, HARRIS, ITA, McMARTIN, RAYTHEON, RCA, SINGER, SINTRONIX, WILKINSON. Many other models also available.



FAST Delivery and FREE Technical Support.

Write For Free List

5869 WAYCROSS AVENUE, EL PASO, TEXAS 79924 (915) 751-2300 FAX: (915) 751-0768

Circle (22) On Reader Service Card

Freeland Products, Inc. Vacuum Power Tube Rebuilders Since 1940. If you don't need TO SAVE MONEY we can't help you. However, if saving money interests you... WE CAN REBUILD YOUR DUDES (used tubes) for about 1/2 the cost of new tubes!

TURNTABLES

Want To Sell

Technics SL 1200 with tonearm & Grado ZF3 cartridge, \$200. B Dixon, WAWC FM, 10129 N 800 East, Syracuse IN 46567. 219-457-8181.

Newcomb 1960 portable radio transcription TT with PA, self contained with amp, 12" speaker in lid. R Myers, R Myers Prods, 222 Lakeview Ave, #216, W Palm Bch FL 33401. 407-832-4607.

RTS-405 stereo TT preamp (2), used 6 mos, \$140/ea + shp. B Lord, Lord Bldg, 13313 SE 208th, Kent WA 98042. 206-631-2374.

Russco Studio Pro B with Micro-trak tonearm, \$50 + shp: Straight Wire Audio PH-2 preamp, \$125 + shp. J Cary, WLKX, 15226 W Freeway Dr, Forest Lake MN 55025. 612-464-6796.

Sparta remote unit w/out mixer; Technic Quartz SP-25 (2) direct drive; Sparta 33 1/3 45 rpm. N Johnson, 92 Higgins Rd, Presque Isle ME 04769. 207-764-0605.

Technic SP-10 MK II with power supply, Audio-Technica arm, stereo cartridge, Fidelity Pro stereo preamp, \$175 + shipping. R Statham, WSTU, 1000 Alice Ave, Stuart FL 34994. 407-692-1000.

Want To Buy

Shure M-236 tonearm & cables for 15". A Wilkerson, WLIL AM, POB 340, Lenoir City TN 37771. 615-986-7536.

The advertising deadline for the October 19 issue of Radio World: September 23

ADVERTISER INDEX

This listing is provided for the convenience of our readers. Radio World assumes no liability for inaccuracy.

Table with 5 columns: Page No., Advertiser, Reader Service No., Page No., Advertiser, Reader Service No. Lists various advertisers and their corresponding page numbers.

Table listing staff roles and names: Publisher (Stevan B. Dana), Associate Publisher (Carmel King), Marketing Consultant (Al Leon), Marketing Assistant (Annette Deutscher), Production Director (Kim Lowe), Production Manager (Lisa Mamo), Publication/Desktop Systems Manager (Julianne Stone), Publications Manager (Lisa Lyons), Classified/Showcase Production Coordinator (Vicky Baron), Ad Production Coordinator (Kathy Jackson), Ad Coordination Manager (Simone Mullins), Circulation Director (Rebecca Seaborg), Accounts Receivable (Steve Berto).

Advertising Sales Representatives

Table listing advertising sales representatives and their contact information: U.S. East: Skip Tash, U.S. West: Dale Tucker, International: Stevan B. Dana, Europe: Dario Calabrese, Japan: Eiji Yoshikawa.

Free Subscriptions are available upon request to professional broadcasting and audiovisual equipment users. For address changes, send current and new address to RW a month in advance at P.O. Box 1214, Falls Church, VA 22041. Unsolicited manuscripts are welcomed for review; send to the attention of the appropriate editor.

FOR ADVERTISING INFORMATION ON Radio World BROADCAST EQUIPMENT EXCHANGE Contact Simone Mullins Phone: 800-336-3045 FAX: 703-998-2966

Auditronics reinvents radio with...

THE *Destiny* 2000

PROGRAM MANAGEMENT SYSTEM



The most exciting NEW advance in radio broadcasting since the advent of computer technology!

You won't have to scrap your existing computer equipment. When the Destiny 2000 Program Management System and Console are installed, it will integrate your current computers and equipment into one master program management system. Your music schedule and traffic schedule computers, as well as your production room hard disk computers, can be networked into one system,

all controlled by the Destiny 2000 console and computer.

It's the control room of tomorrow! The clutter is gone. The commercial copy, the music and traffic logs are in the computer. The CD's are in the jukebox and the tape carts are in the hard disk storage. The control room of tomorrow is here today... tapeless and paperless.

The Sound Of Perfection

AUDITRONICS

Every City Has One.

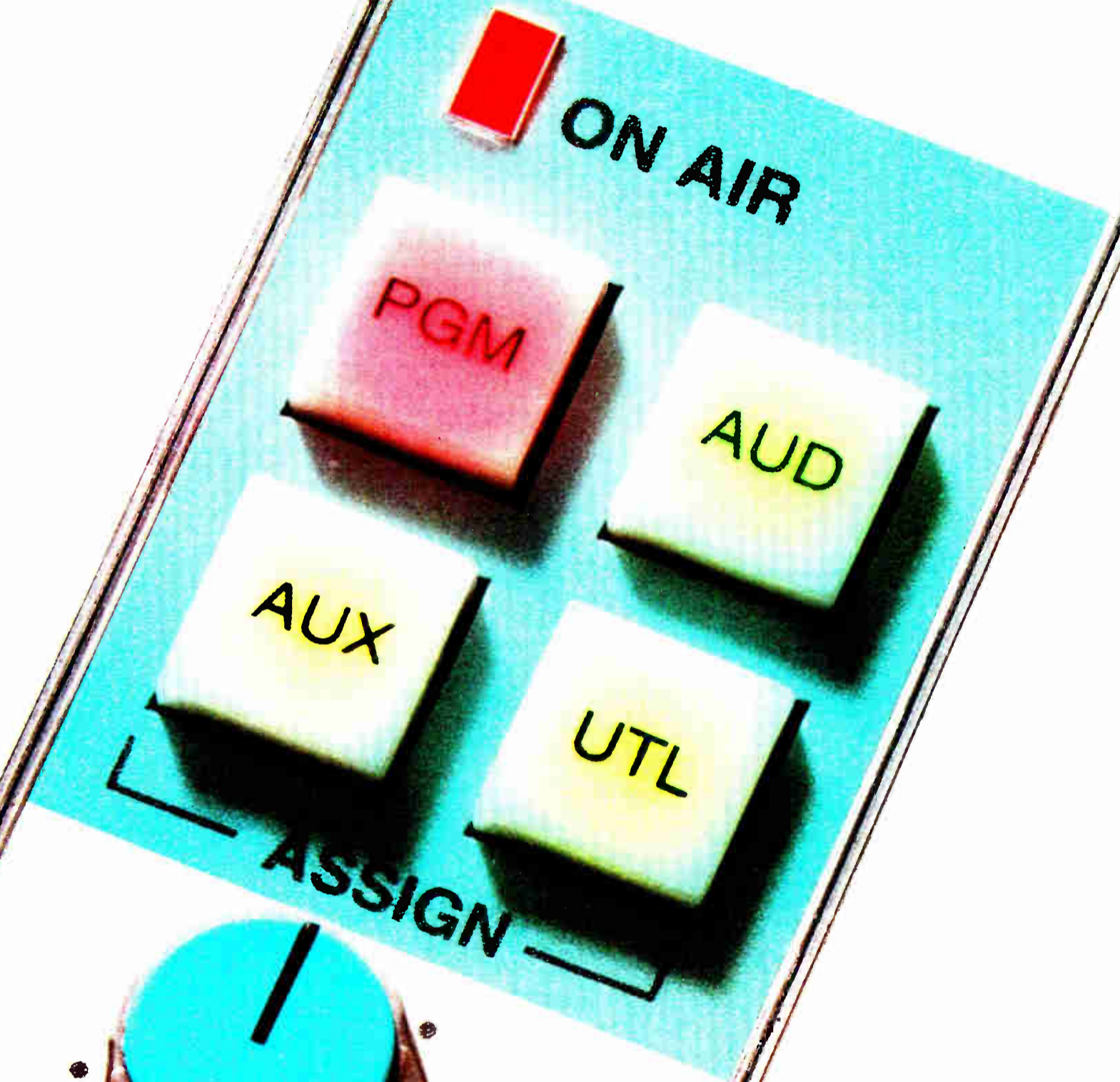

A Number One Station.

The A-6000 On-Air Console is for you.

 **Wheatstone[®] Corporation**

7305 Performance Drive, Syracuse, NY. 13212
(tel 315-452-5000 / fax 315-452-0160)