

\*\*\*\*\*3-DIGIT 857  
 J750737 D11 9007 5739 815  
 BARRY WISHKIND  
 2033 S AUGUSTA PL  
 TUCSON AZ 85716

# RadioWorld®



Studio Sessions  
 See pp. 23-34

Vol 18, No 10

Radio's Best Read Newspaper

May 18, 1994

## Clinton Looks at Doubling FCC User Fees

by Randy Sukow

**WASHINGTON** Broadcasters and all other FCC licensees, who are to pay for "user fees" to the commission for the first time in fiscal year (FY) 1994, can expect a huge increase in the fees—perhaps doubled for many licensees—in FY 1995, if the Clinton Administration has its wish.

Starting next year, the administration hopes to have the FCC funded entirely by user fees with no support from the federal treasury. About half of the FCC's current budget is supported by \$82 million in user fees, which were approved by Congress for the first time last year.

Broadcasters are expected to pay an estimated \$18 million in fees this year. Radio stations will pay \$200-\$900 and TV stations will pay \$4,000-\$18,000, depending on the class of the station. The exact

amount of the increase each station will pay under the new plan is unknown.

The administration's FY 1995 original budget plan earmarked \$167.4 million

bear the costs of imprisoning illegal aliens convicted of felonies.

National Association of Broadcasters

President Eddie Fritts reacted with "outrage and incredulity" to linkage between FCC user fees and a government program not related to communications policy.

"Clearly, the United States must deal effectively with the problems of illegal immigration," Fritts said in a letter to Leon Panetta, director of the Office of Management and Budget.

"However, to suggest that the way to pay for this assistance is to require broadcasters and other FCC

licensees to pay higher 'user fees' is nothing short of astounding." Indications are that FCC licensees could eventually face much greater burdens beyond the new user fee plan. An unofficial plan floated by the administration on Capitol Hill late last month would charge them an additional \$4.8 billion in "spectrum royalty fees" over five years to make up for lost tariff revenue resulting from last year's GATT agreement.

1994. The Bush Administration, with the support of House Energy and Commerce Committee Chairman John Dingell (D-Mich.), proposed partial FCC funding through user fees in FY 1992 and 1993. The fees failed in the Senate, however, due to opposition from Commerce Committee Chairman Ernest Hollings (D-S.C.). Fees were not included in President Clinton's first budget proposal for FY 1994 early last year, but after a series of eleventh-hour compromises, the fees were added to the final budget bill passed late last summer.



courtesy of the Supreme Court Historical Society—photo by Ralph D. Jones

for the FCC, with \$95 million in user fees. The new proposal retains the same level of funding, but diverts the remaining \$72.4 million from the treasury to the State Criminal Alien Assistance Program, a \$350 million proposal to help the states

and other FCC licensees to pay higher 'user fees' is nothing short of astounding."

Before any new fee proposal can be put into effect, the administration must win approval of authorizing legislation by the Senate Commerce Committee and House Energy and Commerce Committee. FCC Chairman Reed Hundt "supports this (\$72.4 million) proposal" and will present a draft of the authorizing legislation to Congress, Panetta said in a letter to the House Budget Committee attached to the fee proposal.

Hundt hinted that a change in the FCC's funding procedures was under consideration during an appearance before the House Appropriations Committee on April 18, a few days before the administration announcement.

"If the commission is to fulfill its responsibilities and the telecommunications industry is to be a growing sector of the American economy, the commission must have a larger resource base," he said.

Hundt said the commission must receive the full \$167.4 million to rebuild the already understaffed agency. The FCC's staff has been reduced by 500 since 1980.

Almost 100 percent of the FCC budget was funded by the treasury before FY

## Philips Introduces Pro DCC

by Mary C. Gruszka

**NEW YORK** Building on its research and experience in developing DCC (Digital Compact Cassette) products for consumer markets, Philips, the inventor of DCC, is expanding its product offering to include hardware and software geared towards professional audio applications.

"We see DCC as the digital high end successor of the analog compact cassette," said Koos Middeljans, General Manager, Philips Key Modules Group. "Now we are taking DCC into other applications."

Philips expects to sell mainly through OEM manufacturers because, as Middeljans explained, "we don't have the right channels or marketing infrastructure in these markets. We provide the information to OEM partners and it is up to them to determine how to use that information."

Some of the new products Philips has developed as an outgrowth of its DCC technology include a DCC workstation, digital signal processor, sample rate converter, and a digitally processed loudspeaker system.

With the announcement of DCC professional equipment, Philips is taking a route already being traveled by Sony—with the MiniDisc cart recorder technology that spun off its own and other manufacturer's products.

The DCC workstation is expected to be available in October in both the U.S. and in Europe. The key component of the system is a DCC

continued on page 7 ▶

## CCA Broadcast Transmitters

The Standard for Reliability Throughout the World.

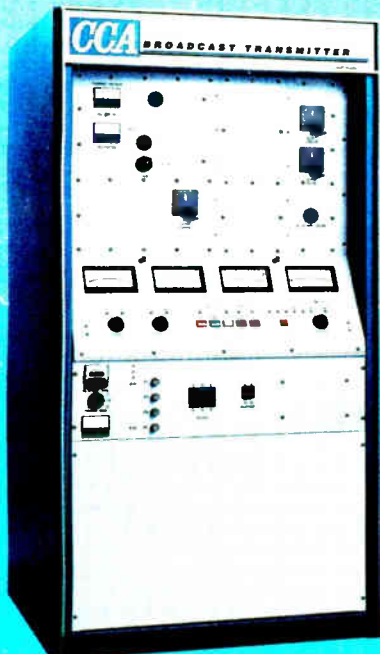

### Available FM Transmitters:

- 2.5 KW 20 KW
- 4 KW 25 KW
- 5 KW 27.5 KW
- 8 KW 35 KW
- 10 KW 45 KW
- 12 KW

# CCA

**CCA Electronics, Inc.**

P.O. Box 426 • 360 Bohannon Road  
 Fairburn, Georgia USA 30213  
 (404) 964-3530 • FAX: (404) 964-2222



Circle (72) On Reader Service Card

# NEWSWATCH

## American Media Sells Stations

**DALLAS** MBD and Chancellor Communications has announced that they will acquire eleven radio stations from American Media for \$150 million.

The stations include WUBE-AM-FM, WYGY-FM in Cincinnati; KTCJ(AM)-KTCZ-FM in Minneapolis; WALK-AM-FM in Nassau/Suffolk, New York; KMEN(AM) and KGGT-FM, Riverside/San Bernardino, California; and WOCL-FM in Orlando, Florida.

MBD Broadcasting/Chancellor Communications President Steven

Dinetz said: "We have been looking for some time for stations in excellent radio markets that are well positioned and run by superb local management. All eleven of these extraordinary radio stations fit that description."

## FCC Denies Claim For RF Review

**WASHINGTON** The FCC has denied a Tampa, Fla., man's request for review of a Mass Media Bureau decision granting a license to WYUU—a station that had been accused of blanketing RF radiation interference.

The commission ruled that the Mass Media Bureau had adequately checked into a claim in 1988 that John W. Tyrone's house and occupants were being exposed to excessive RF radiation.

In denying the review, the FCC staff reviewed a WYUU consultant's measurements taken on the Tyrone property on Sept. 26, 1988, which showed that the RF radiation levels did not exceed federal standards.

Radio frequency radiation from broadcasters and other sources, such as power lines, has become a highly charged environmental issue with local jurisdiction considering strict rules with regard to tower placement.

The NAB has opposed such local pre-emption and generally supports the FCC's current revision of the ANSI

exposure standard to better take into account environmental concerns using the latest scientific information.

## Initial Arbitron Survey Rate Up

**NEW YORK** The first sixteen markets of the Winter 1994 Arbitron survey showed a 4.3 point response gain over the Winter 1993 response rates. Compared to the Fall 1993 survey, the average metro response rate is up 6.7 points overall, according to Arbitron.

The Winter 1994 average metro response rate for the 16 market survey was 36.8 percent, compared to 32.5 percent a year ago. The Fall 1993 rate was 30.1 percent.

Because the response rate is up, Arbitron expects to see "an equivalent response rate gain for the rest of the surveys, according to Arbitron."

When looking for a digital audio system for automation of satellite programming or live assist, there would appear to be many choices. But if you're looking for a system which is flexible enough to give you total control without sacrificing your sanity, there is only one choice. The Phantom by RDS.

You will see the difference as soon as you see the Phantom in action. The display provides you with all of the information you need to see in a clean, concise manner, without the crowded look that you'll find in other systems. If you are familiar with the most popular software on the PC, then you may already know how to use the Phantom. The Phantom's pull-down menus guide you through all of the steps involved in setup and daily operation, from creating and scheduling clocks to creating and editing logs.

## The PHANTOM Digital Audio Automation

The Phantom ends the confusion of automation by keeping everything organized. The Phantom simplifies your daily operations by keeping information such as input changes, voice changes, and clock changes in their own individual schedules rather than in the log. You can leave those liners and other voice drops out of the log because the Phantom will do them for you. The Phantom allows you to date new schedules to begin weeks, months, or even years in advance. When your satellite network informs you that there will be a voice substitution on Thursday, two weeks from today, you can prepare for it *today*.

The Phantom can retime spots to fit them cleanly into a satellite break without inserting silence, overlapping, or running late. The Phantom



can create reports to keep you informed on a number of topics, from a list of expired spots to an analysis of potential mistakes in your log. The Phantom also maintains a history of system activity.

The Phantom has the features that others would want you to believe are theirs exclusively. The Phantom remains *completely* functional during recording, sensing relay closures and starting breaks as easily as it does when it is not recording. The Phantom can fill incomplete breaks with spots from a list you specify without ruining product separation.

While other systems tie your hands and limit your flexibility by only offering 3 or 4 inputs, the Phantom gives you 6 stereo inputs, using its AMX-84 solid state switcher, with the option of increasing the number of inputs to 14 or more. If your station is News/Talk, you know how important this can be.

The Phantom allows you to change the sampling rate, digital format, and stereo/mono settings at will to meet your needs for an individual spot. The Phantom offers a number of digital formats, including the new Dolby AC-2 format, as an option.

Call us today to find out how your station can benefit from the advanced technology of the Phantom and the experience of RDS.

**1-800-521-5222**

912-987-2501 • FAX: 912-987-7595

P. O. Box 980, Perry, GA 30169



**REGISTER  
DATA  
SYSTEMS**

# Index

## FEATURES

<b>FCC to Examine EEO Reform</b>	10
by Harry Cole	
<b>Harrisburg Franksters Test Modern Home Appliances</b>	12
by Alan Peterson	
<b>Multitine Aids On-Air Audio Tests</b>	13
by Tom Vernon	
<b>Transistors Allow High-Current Flow Control</b>	15
by Ed Montgomery	
<b>Computers Let Radio Ride Highway</b>	17
by Barry Mishkind	
<b>Workbench</b>	18
by John Bisset	

## STUDIO SESSIONS

<b>MD Cart Technology Impressive under Test</b>	23
by Ken C. Pohlmann	
<b>Denon DN-990R Well Suited For Production Room, On-Air</b>	23
by Chris Crump	
<b>Mixes Are 'Easy' With Monitor One</b>	24
by Bruce & Jenny Bartlett	
<b>The 'Tapeless, Diskless' Flashback Recorder</b>	25
by Frank Beacham	
<b>AKG Mics Offer Varied Features</b>	26
by Ty Ford	
<b>Transporting Ads by TMX Network</b>	33
by Mel Lambert	

## BUYERS GUIDE

<b>USER REPORTS</b>	
<b>Tannoy Near-Field Monitors Score Well in Test</b>	35
by Bruce & Jenny Bartlett	
<b>ATI NanoAmp Mixers Ease Remotes</b>	36
by Tom MacDonald	
<b>AKG Mics Record for Radio</b>	36
by John Moran	
<b>Yamaha Monitors Give Accurate Sound</b>	39
by Fred Guarino	
<b>Broadcast Tools Eases Communications</b>	41
by Dwight Small	

## TECHNOLOGY UPDATES

Nady	42
Crown Audio	42
Genelec	42
beyerdynamic	42
Neumann	42
Electro-Voice	44
Wohler	44
Shure	44
Ramsa	44
Digital Designs	46
Galaxy	46
Lectrosonics	46
Vega	46
Audix	49
P.S.B.	49
Sanken	49
AIR Corp	49
Demeter	49
Microtech Gefell	50
Clear-Com	50
KRK	50
D.W. Fearn	50
Benchmark	51
Auratone	51
Speakerkits	51

# Broadcasters Can Be PCS Players

by Randy Sukow

**WASHINGTON** The FCC cleared the way for rapid roll out of personal communications services (PCS) during its April public meeting by adopting the rules and procedures for spectrum auctions.

The commission will auction licenses for the first time this summer (an exact date was not yet available at press time), an alternative to the comparative hearing method used for several decades, and the lottery method, which has been used with great controversy over the past decade.

The first auctions will be for a total of 3,353 narrowband PCS licenses in the 900 MHz band, which are expected to be used for advanced paging services. (The commission is still working on the rules for broadband PCS auctions. Broadband PCS could potentially deliver the same services narrowband PCS as well as wireless voice and video phone communications.)

In a related proceeding, the FCC also authorized its staff to begin auctions for Interactive Video and Data Service (IVDS) licenses at 218 to 220 MHz (just above VHF-TV channel 13). IVDS is a low-power digital consumer transmission system designed for real-time, interactive broadcast and cable TV applications.

## Radio's competition

FCC Chairman Reed Hundt said he envisioned two possible scenarios for the "information superhighway." Services like PCS and IVDS could be controlled by a few wealthy individuals and powerful companies that may or may not have the incentive to provide imaginative, advanced communications services.

"The second vision is that there will be a great, varied mix of entrepreneurs that will provide many alternatives and choices," Hundt said.

Commissioner Andrew Barrett said he shared Hundt's vision, and said one way to avoid telephone industry domination is to insure that broadcasters have a chance to compete. "I want all participants to be involved, broadcasters

particularly, and the cable industry because they have a lot of programming they can bring to the market," he said.

Broadcasters have the choice of bidding for PCS licenses, competing with PCS using their broadcast assignments or participating in the information superhighway on both levels.

Narrowband PCS is likely to be used for many of the same types of applications that radio broadcasters will be able to transmit through Radio Broadcast Data Service (RBDS), high-speed FM subcarrier systems and future data communications associated with digital audio broadcasting.

Broadcasters and PCS operators could potentially compete with their own highly efficient paging systems that not only page users, but send full messages; electronic text and fax transmission services and global positioning. Narrowband PCS could have a competitive advantage, however, because it is interactive.

"There have been proposals for voice mail and two-way paging services where you can have a response channel," said Robert Pepper, chief of the FCC's Office of Plans and Policy.

PCS will also have the advantage of being available from national, regional and local providers. Consumers will be able to receive pages and messages from anywhere in the country, even when they are away from home.

Eleven of the narrowband licenses are to be 50 kHz national assignments and another 30 will be awarded to licensees in five regions of the U.S. There will be 360 licenses (50 kHz) awarded in the 11 large metropolitan areas that qualify as major trading areas (MTAs), and 984 in communities defined as basic trading areas (BTAs).

The remaining 1,968 licenses will be 12.5 kHz assignments to be divided between the MTAs and BTAs. (Bidding for the 12.5 kHz licenses will be limited to current paging-service licensees.)

## Procedures

The commission intends to test its new auction rules with the comparatively small-scale PCS and IVDS sales before

applying them to broadband PCS and other future services that are likely to attract much higher bids.

The Congressional Budget Office estimates the eventual total revenue from PCS auctions will be \$6 million, but there is no breakdown of how much is likely to come from narrowband as opposed to broadband PCS.

Commission staff will assess the first rounds of auctions to decide whether its rules encourage the full potential prices, while at the same time insuring licensees go to a significant number of women, minorities and small business, as Congress mandated when authorizing auctions last year.

The commission will have the authority to change the rules quickly if its diversity goals are not met, Pepper said. "We can provide flexibility to revisit this much more rapidly [than six months]. Congress told us to try different methods," he said.

A sequential series of simultaneous, multi-round auctions will be held for most of the contested PCS licenses. The commission will hold either oral or single-round sealed auctions when it estimates the value of the license does not justify the expense of the multi-round procedure. (It will use the single-round

sealed method for all 12.5 kHz licenses.)

All bidders are required to pay \$1,000 or more before the auction, depending on the number of licenses they are seeking. Winners must pay at least 20 percent of the purchase price immediately after the auction and the remainder of the price within five business days after the licenses is awarded. The FCC will impose monetary penalties on bidders who default on payments.

Bidders that qualify as small businesses will be allowed to pay 10 percent after the action, 10 percent five days later and the remaining 80 percent in installments through the term of the license. Interest will be assessed only during the first two years of payments. After considering savings in interest payments and amortization on the value of the license, the FCC estimates the installment plan will give small businesses a 20 to 30 percent bidding advantage over larger businesses.

Companies controlled by women or minorities will be given a 25 percent discount off the highest bid.

## Interactive TV

The procedures for IVDS auctions will be "basically the same" as the narrowband PCS rules, Private Radio Bureau Chief Ralph Haller said. IVDS bidders owned by women and minorities will have a similar package

continued on page 6 ▶

## Your Station Operates 24 Hours a Day So Do We

Meet the Continental Service Team. They are available 24 hours a day, 365 days a year to assist you with solutions to any technical service questions. These people have many years experience troubleshooting equipment in the field and are knowledgeable about all Continental transmitters and accessories.

**Continental offers the best service in the broadcast industry.**

*Dave Chenoweth*

**Dave Chenoweth**

*Ken Branton*

**Ken Branton**

*John Hutson*

**John Hutson**

*Jan Aerts*

**Jan Aerts**

**Service 214-388-5800**



**Continental Electronics Corporation**

P.O. BOX 270879 DALLAS, TEXAS 75227-0879 214-381-7161 TELEX: 73-398 FAX: 214-381-4949

## BIG...RICH...FULL DIMENSION CONCERT SOUND

The CP2013 is the only composite processor with a fast, peak responding AGC. **Why?** Because most AGC amplifiers are too "envelope destructive" to be used this way.

### The Benefits?

- Incredible spatial effect due to enhanced L-R
- Eliminates excessive subsonic energy
- Much cleaner than conventional composite clippers
- 1.5dB louder, due to low second harmonic clipper, converts "would be" distortion into useful modulation.



COMPROC CP-2013

**Other features** include two composite outputs, and a new zero phase shift pilot feed-through circuit requiring no setup.

**BIG SOUND...MEANS BIG NUMBERS**

**CALL NOW!!**

**HNAT HINDES inc**

42 Elaine St., Thompson CT 06277  
203-935-9066 or 203-935-9242  
FAX: 203-935-9919

# Uncle Sam Wants You to Dig Deeper

**WASHINGTON** Greetings from Washington indeed. Can you even begin to believe this? Not only has the Clinton administration not even begun to collect its recently instituted user fees from broadcasters, but it is now talking about doubling the user fees and instituting "spectrum royalty fees" (see story, page 1).

If I were you, I'd be reaching for my sta-



tionery right about now. Crank out letters to the Congress, the NAB, the FCC, the White House—anybody who could have an impact on these very real and very threatening matters.

I do believe that every citizenship carries with it certain obligations, among those, monetary support of government, but these latest White House moves turn obligation into burden. The administration needs to come up with better management ideas to control its budget (read: better government).

As broadcasters, your charter is to inform, educate and entertain the communities you serve. If you let these proposals go unchallenged, it could happen that your charter expands to include social welfare and upkeep of our penal system. At the same time, you will be asked to upgrade your facilities and equipment to enter the digital broadcasting era. (Do your calculators expand to do all this addition?)

The job of this paper is to serve you, the broadcasters. All the editors here at **RW** are dismayed by these latest proposals, and we have some serious problems with both the long- and short-term questions we are seeing ignored.

The Clinton Administration and its choice to head the FCC appear to be dangerously

oblivious to the business realities of broadcasting and other media.

The first hint of this came several weeks ago, as regional Bell operating companies and major cable system operators began backing away from their landmark consolidation deals, which were to speed the construction of broadband networks worldwide. The administration and the FCC denied that a 10 percent rollback in newly regulated cable rates could have anything to do with those deals falling through.

Then, in an interview with the Washington Post, FCC Chairman Reed Hundt implied that the cable industry should be grateful for having its rates chopped by the federal government. You see, lower rates mean that people who could not afford cable before will now be able to subscribe and cable companies will make more money.

Cable companies nationwide that labor mightily to serve their customers and yield a healthy profit must have been shocked to learn that a federal government agency

knows cable markets and can price cable products better than they can.

Now, if the Clinton Administration has its way, all communications industries that must get their licenses to operate through the FCC will divide up over \$1 billion in "user fees" and "spectrum royalty fees" for at least the next five years.

Under the current user fee system, in which broadcasters are expected to pay about \$18 million out of a total \$85 million in fees, individual radio stations will pay between \$200 and \$900 per license, and TV stations will pay between \$4,000 and \$18,000.

If the illegal-alien and GATT funding proposals pass, and the individual fees are raised proportionally for each FCC-regulated industry, radio stations can expect to pay about \$2,300 to \$10,500 per license (approximately \$47,000 to \$210,000 for TV stations). I am not pulling these numbers out of a hat—they were arrived at using NAB estimates.



## Diane Sawyer Fills in for Paul Harvey

**NEW YORK** ABC News's Diane Sawyer added to her list of credentials Thursday April 7th as she filled in for Paul Harvey's News & Commentary. Congratulating her on the broadcast were ABC Radio Networks' Senior Vice President of Marketing, Darryl Brown (left), and Vice President of ABC News Radio, John McConnell (center).

Perhaps broadcasters will be able to win some relief from those hefty increases. Broadcast public interest responsibilities and the still-low revenue figures at stations in many parts of the country may convince the FCC to shift more of the load to other industries.

But it will be cold comfort for the rest of the country if the cable, telephone and cellular industries, which are expected to bear the costs of building a broadband "super-highway" in the next decade, are asked to take on a greater share of the fee burden.

And what about radio upgrading to digital broadcasting and, last but not least, finally, parity for AM with its FM brethren?

How many years will the communications technologies of the future be delayed while communications companies are paying to jail illegal immigrant armed robbers?

★ ★ ★

Ira (Ike) Coron, appointed chairman of the board and CEO of California Amplifier Inc., replaces Barry Hall, who resigned to pursue other interests.

Coron joins the company from TRW Inc., where he had been serving as vice president and general manager in the TRW automotive sector.

Jack Goodman named vice president and policy counsel, legal and regulatory affairs at the National Association of Broadcasters. Goodman, who joined the NAB in 1990 as special counsel, will develop and coordinate NAB regulatory and legislative policy objectives. Goodman will work with NAB Executive Vice President and General Counsel, Jeff Baumann.

Winfield Donat appointed president, Lawrence Behr Associates. Donat joins LBA after 26 years of service in the U.S. Navy, most recently as Superintendent of the U.S. Naval Observatory in Washington, D.C.

Bill Hooper joins Vallie/Gallup as vice president. Hooper had been managing WWIN-AM-FM and WERQ-AM-FM (a duopoly combination) for United Broadcasting.

Stephen Kahofer appointed director, national sales at United Press International. Prior to joining UPI, Kahofer served as sales manager for corporate sales at the Associated Press. Before AP, Kahofer spent 12 years with Dunn & Bradstreet Corp.

## Transmitter Control can be a Bear

You need to make sure you can stay on the air and stay legal. At the same time, you need to keep operating costs under control.

Choosing the right remote control system is the first step.

The ARC-16SA\* from Burk Technology lets you control your transmitter from any phone. You can establish off-premises control points for unattended operation, or supervise non-technical operators by phone.

The annual savings can be thousands of dollars.

The ARC-16SA is part of a modular system. For full-time control, add a studio unit. Multi-site options make it easy to control several transmitter sites or even control studio equipment such as program automation.

Call now for your copy of our new catalog, then ask us to show you how we can improve your operation and your bottom line.

Call TOLL FREE  
1-800 255-8090

**BURK**  
TECHNOLOGY

7 Lomar Drive, Pepperell, MA, 01463 (508) 433-8877

\*bear telephone not included

READERS FORUM

If you have comments for Radio World, call us at 800-336-3045 or send a letter to Readers Forum (Radio World, Box 1214, Falls Church, VA 22041 or MCI Mailbox #302-7776). All letters received become the property of Radio World, to be used at our discretion and as space permits.

**"Thankless" revisited**

Dear RW,  
I don't know what world Frank McCoy is from (*Readers Forum*, April 6). I wish I had it that good at the TV and radio stations where I am chief engineer.

Jim Wojciechowski hit the nail on the head. Light bulbs and water cooler bottles must be fixed and the news anchor's mic must be repaired when he forgets to unhook it and walks away from the set.

Sometimes the TV transmitter goes down and must be repaired NOW!, and the FM transmitter goes down 20 minutes later. What do I do first? There are only 27 hours in a day.

Mr. McCoy should get a job in the real world of broadcasting and put in an 80-hour work week while getting paid for 40. He should drive his own car up to a TV transmitter site on a hill top his poor, sick car just will not climb at 3 a.m.

James E. Appleton  
Elmira, N.Y.

Dear RW,

In regard to the on-going commentary on the plight of radio engineers (see "Radio Engineers: Leading a Thankless Life" by Jim Wojciechowski, RW, March 9), I ask all general managers or anyone who reads this column to think about the salary level that you would offer an individual at your AM/FM combo (not simulcast) stations in return for carrying out the following duties over a span of five years:

Engineer—Installs two on-air studios, a newsroom and a production studio, FM transmitter and STL gear at new site, and performs all engineering maintenance for both stations. Outfits new remote van. Is on-call at all times for everything from setting up remotes to fixing problems with church feeds, as well as to fix plumbing, fluorescent lights, auxiliary generator, telephones, typewriters, computers and peripherals.

Music director—Increases CD library from six titles to thousands at virtually no cost to the station other than postage and

phone calls.

Program director—Oversees six air personalities and some college interns. Does own daily four-hour shift. Serves as sports-caster, news director and farm director.

Production manager—Produces commercials that win top awards from the state broadcasters association and that some clients prefer over spots produced by larger-market stations.

Operations manager—Job description gives responsibility for "everything but the sales department." Manages traffic department and installs traffic computer and software. Trains traffic director.

The pay for all of this is \$18,000 a year, with no benefits. I have been in the business for nine years now, and just turned 35. I am in good health, but stressed out as hell.

To those who do not want to get into this type of situation, I advise acting like you do not know anything or care about anything to do with the operation of the station, with the exception of your own board shift.

Name withheld at  
writer's request

Dear RW,

I hope you billed Mr. McCoy for his commercial disguised as an editorial. How galling of him to toot his own horn while belittling the honest observations of a disillusioned engineer.

As the Wojciechowskis of this world leave the broadcasting industry to better their lives, companies such as Mr. McCoy's may step in to fill the void. What they will never fill, however, is the dedication offered by a full-time engineer to a single employer. A firm servicing the needs of numerous stations cannot focus exclusively on any one of its clients.

It is cheaper than employing a full-time engineer, but you get what you pay for.

Bob Jenkins,  
retired engineer  
Charlotte, N.C.

Dear RW,

I read the "Guest Commentary" by Jim Wojciechowski with keen interest. I do not believe we are related, but his autobiographical piece on radio engineers touched the very experience of my Montana radio days. I complement his therapeutic writing.

I, too, believed giving first-class performance was reward enough. The perception of being a second-class citizen bothered me. For other engineers who relate to Jim's article, I encourage the alternatives. There is life after broadcasting.

I left that sclerotic and jurassic lifestyle six years ago, to work in Antigua for three years and the Philippines for three more. Currently, my wife and I, with our house girl and cat, look forward to our new assignment in Sri Lanka.

A personal message for Jim: Warm regards and I wish you well in your new career, wherever you go.

Thomas H. Wojciechowski  
U.S. Embassy, VOA

**NAB is on target**

Dear RW,

Regarding the recent Emergency Broadcast System (EBS) discussion, the

**Alien Proposal**

A year ago, the FCC did not charge its licensees "user fees" to cover the cost of regulation, and there appeared to be insurmountable opposition to fees on Capitol Hill.

Look at how much has changed: from zero to a proposed \$167.4 million in a year is a dizzying pace. Broadcasters and all other FCC licensees should be frightened.

Before widespread panic sets in, the communications industry can take some solace in the Clinton Administration's unbelievably clumsy lobbying for the fee increases, which could well doom them for this year.

First the Office of Management and Budget (OMB) sent its formal FCC fee-increase/illegal-alien-incarceration proposal to the Hill without consulting House Energy and Commerce Committee Chairman John Dingell (D-Mich.) and Senate Commerce Committee Chairman Ernest Hollings (D-S.C.), whose committees must approve special authorizing legislation before any new fees can be charged.

Then the administration went behind the committee chairmen's backs again only a week later, to float the idea of charging an additional \$4 - \$4.8 BILLION in "royalty fees" over five years to cover tariff shortfalls resulting from last year's GATT agreement.

Dingell replied with an icily toned letter to OMB Director Leon Panetta, asking him to stop "raiding programs in our jurisdiction."

Political bumbling may stall new fees for FY 1995, but FCC licensees are far from safe. The Clinton Administration believes communications companies hold inexhaustible piles of ready cash for taxing.

Even if the administration wins the money it wants to house illegal aliens and pay for GATT, it could be back later for more when another worthy cause that has nothing to do with communications must be funded.

These fees are being pushed by the same group that is asking communications companies to invest billions in a broadband National Information Infrastructure. The next time Vice President Al Gore stumps for the "information superhighway," it will be difficult to take him seriously.

—RW

NAB position to delay any change until further study is made is right on target. A careful review of the existing system should be done before rushing into any new and expensive high-tech reworking of the EBS plan.

Most broadcasters did not actively take part in the recent FCC/industry tests and proceedings on EBS because we were under the impression that the commission was essentially considering the original NAB proposal to shorten and reduce the number of tests. Virtually every broadcaster agrees with this suggestion.

There have been suggestions that the public may be desensitized to the existing EBS

tones. I believe that the opposite is true. We have educated the public to understand and respect these EBS signals and virtually all listeners know exactly what they mean.

Finally, in a recent press conference, Vice President Gore indicated that the National Weather Service will be expanding its radio coverage to provide an automatic alerting system to the entire country. How this will impact on the existing broadcast EBS system should be investigated.

Certainly we should not be in a rush to discard a system that is working quite well and is understood by the public.

Herbert P. Michels, president  
WKMB(AM) Stirling, N.J.

**GUEST EDITORIAL**

by Ken Pohlmann

Despite the good sound that MiniDisc is capable of delivering, as is the Digital Compact Cassette (DCC), it is the question of sound quality that will dog these technologies—whether professional or consumer.

Many users are rightly concerned about the cumulative effects of data compression through a production and broadcast signal path and feel that compression should only be used when necessary. In that respect, the DN-990R, the Sony MDR-B2P and Otari MD cart recorder use compression unnecessarily because a cart machine user normally does not need 74 minutes of playing time.

It could be argued that professional MD cart machines should employ the recently-introduced MD-DATA format (designed for non-audio, computer storage) which eschews data compression. This format could provide about 15 minutes of playing time over its 140 megabyte capacity—fully adequate for most applications. Indeed, that might be the ideal cart medium: digital, random access, non-compressed, editable, with full labelling features. An MD-DATA cart machine that gave the user the opportunity of choosing between longer recording times (with compression) and shorter playing times (without compression), as well as playback of pre-recorded MDs, would be a real winner.

In my opinion, if MD wants to become as ubiquitous as the cart, Sony must admit that ATRAC is not suitable for all audio applications, and provide a MD-DATA cart machine. In that case, MD carts would almost certainly succeed, even if consumer MDs failed. Of course, the consumer DAT format debacle has already shown that with enough wrong decisions on the part of manufacturers, it is always possible to snatch defeat from the jaws of success.

**Radio World**

Vol. 18, No 10 May 18, 1994

- Editor ..... Lucia Cobo
- Managing Editor.....Randy Sukow
- News/Studio Sessions Editor ..... John Gatski
- Associate Editor.....T. Carter Ross
- Contributors .....Frank Beacham/N.Y.,  
Bruce Ingram, Pamela Watkins, Nancy Reist
- Technical Editor.....John Bisset
- Technical Advisor.....Tom McGinley
- Editor (International).....Alan Carter
- Managing Editor (International).....Charles Taylor

Radio World (ISSN: 0274-8541) is published bi-weekly by Industrial Marketing Advisory Services, Inc., 5827 Columbia Pike, Suite 310, Falls Church, VA 22041. Phone: 703-998-7600, Fax: 703-998-2966. Second-class postage rates are paid at Falls Church VA 22046 and additional mailing offices. POSTMASTER: Send 3579 forms and address changes to Radio World, P.O. Box 1214, Falls Church VA 22041. Copyright 1994 by Industrial Marketing Advisory Services, Inc. All rights reserved

—PRINTED IN THE USA—

**Next Issue of  
Radio World  
June 1, 1994**

# PRC Examines New Digital Trends

by Stan Barr

**SAN ANTONIO, Texas** More than 1,100 station managers, programmers, independent producers, public radio network representatives and exhibitors gathered at the glittering Marriott Rivercenter Hotel in downtown San Antonio last month for the largest Public Radio Convention/Multicultural Producers Forum ever held.

The five-day annual event kicked off on April 8 with the Multicultural Forum dinner and orientation. Participants from every state as well as overseas delegates met Corporation for Public

Broadcasting (CPB) and National Public Radio (NPR) organizers and peer producers. (There are over 500 public radio stations throughout the United States, Latin America and Europe.)

## NPR conferences

On the following day, the Public Radio Conference began with an action motto, "Seize the New Day—Meet the Challenges of the Multimedia Revolution." A broad range of subjects were addressed at the conference, including direct digital and cable broadcasting, information superhighways and multimedia telecommunications.

The first full day of the conference opened with keynote speaker James Cullen, president of Bell Atlantic. Cullen's talk was followed by a speech

**Engineers had the opportunity to meet with experts in digital field recordings.**

on public radio information infrastructure by Larry Irving, assistant secretary National Telecommunications and Information Agency (NTIA).

One of the many highlights of the PRC was the presentation of annual awards of excellence by the CPB. Out of 230

entries, 21 programs were honored during 1993. "When you hear these programs, you know you're listening to something special," said Richard W. Carlson, CPB president and CEO. "They represent public radio's very best work."

## Newest of problems

Bobby Walker, program/music director WJSU FM, a station connected to Jackson State University, Fla., said, "Some of the many challenges facing programmers are the need to increase multicultural programming, adapt to new and sophisticated technologies and cope with an avalanche of informative and educational material available via satellite."

Representatives of regional networks such as Rural America Radio, Ohio Public Radio, Rocky Mountain Public Radio, Southern Public Radio, California Public Radio, Eastern Public Radio, West Coast Public Radio, Public Radio in Mid-America, Florida Public

continued on next page ▶

## WELCOME TO THE DIGITAL WORLD OF DIGILINK

- Replace cart machines live On Air while adding walkaway CD, Satellite, or Tape automation
- On Air Base Price starts under \$8,000
- 8 Track Editor base price starts under \$5,500
- Smallest systems start at 10 hours stereo audio storage (20 hours mono)
- Network more than 15 Digilink workstations

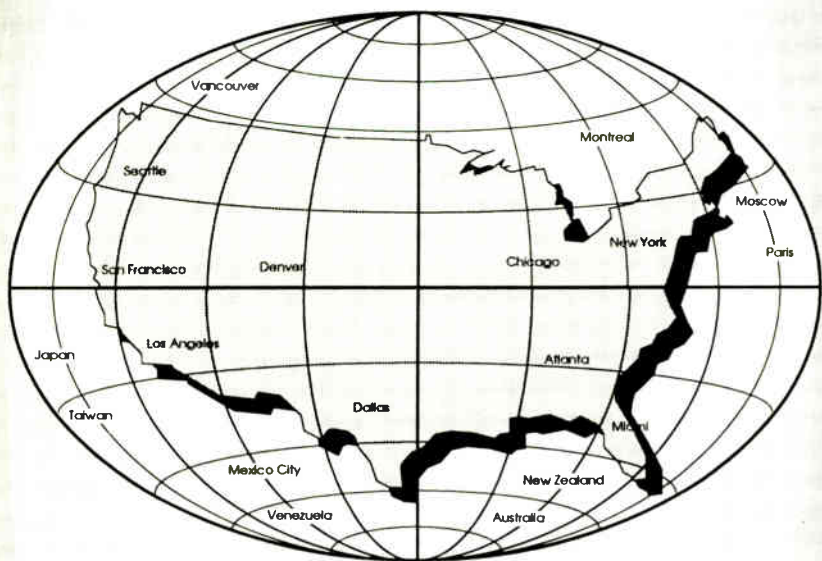

With over 500 workstations sold worldwide in the last 18 months and more than 400 of those workstations sold in the U.S.A, it is little wonder that Digilink is the #1 choice for a digital audio hard disk workstation for professional radio broadcasting. Whether for On Air, Production, News, or Automation... Digilink does it ALL.

For more information about the #1 selling digital audio workstation for Radio, call or write...

303-224-2248

# ARRAKIS

© 1993 Arrakis Systems inc. 2619 Midpoint Drive, Fort Collins, CO. 80525

Circle (14) On Reader Service Card

World Radio History

## FCC Looks at Some Options For Spectrum Auction Plans

**WASHINGTON** While it was approving the rules for spectrum auctions last month, the FCC also began considering how to use other bands that are likely to be put up for auction in years to come.

The commission asked for public comment on how to use 50 MHz of government controlled spectrum that the FCC is transferring to the private sector to encourage advanced wireless communications businesses. It is the first of a total of 200 MHz of government spectrum under 5 GHz that Congress ordered reas-

signed over the next 15 years in an act passed last year.

The law requires the commission to adopt regulations to reassign the first 50 MHz by Feb. 10, 1995. Three blocks of spectrum are under consideration: 2390 to 2400 MHz; 2402 to 2417 MHz, and 4660 to 4685 MHz.

The commission is seeking comments on the best potential use of the frequencies and how to deal with spectrum sharing that will still sometimes be needed in the 2402 to 2417 MHz and 4660 to 4685 MHz blocks. Allocations in 4660 to 4685 MHz block will also be limited by international agreements.

In other actions, the commission asked for public comment on positions to be adopted for the coming World Radio Conference (WRC) and on possible reform of its current Equal Employment Opportunity (EEO) rules (see "Coles Law," page 10).

The agenda for WRC, scheduled for November 1995, was set during the WRC-93 conference. It will deal with satellite communications issues that were not settled during the 1992 World Administrative Radio Conference, as well as the issue of future high-frequency broadcast services.

In addition to public comments, the FCC will develop its positions with the help of an industry advisory committee and through consultation with the National Telecommunications and Information Administration and the State Department.

In the 1992 Cable Act, Congress ordered the FCC to write a report on the effects that law's EEO requirements for the cable industry have had on minority opportunities in all communications businesses. That report is due in October 1994.

The difficulties small-market broadcasters have hiring and retaining minority employees and possible regulatory relief for small-market broadcasters will be among the main topics of inquiry. The FCC will also attempt to define "small-market broadcaster" for the purposes of EEO.

## Broadcasters' PCS Potential

▶ continued from page 3

preferences. "You're looking at a cumulative advantage here of approximately 40 percent," Pepper said.

IVDS auctions will differ slightly from narrowband PCS sales. All auctions will be by either oral or sealed single-bid. Bidders will be required to show a \$2,500 cashier's check before being allowed a place in the auction room.

Licenses will be awarded in sequential order by market size, starting with the tenth largest market. There will be no auctions in the top nine markets, in accordance with a Congressional mandate.

The IVDS proceeding was initiated in the late 1980s at the request of EON Corp. (formerly known as TV Answer), a Reston, Va., firm that is promoting a system to transmit low-power digital signals from consumers devise to a black box outside the home which uplinks data by satellite or land lines to a central computer.

The EON system is designed to transmit yes or no impulses, which can be configured so that consumers can play along with TV game shows, cast votes in instant viewer polls and quickly order pay-per-view programs or home shopping merchandise.

# Philips Targets DCC Toward Pros

► continued from page 1

recorder-player that can be mounted in a tower or a desktop PC. The system also includes dedicated PC interface cards that have analog/digital inputs and outputs and internal connections to a computer. Through application-specific Windows software, the DCC bitstream information is loaded onto a hard disk for editing, processing, and playback.

Three versions of the workstation are currently being offered—jingle creation and playback, DCC pre-mastering and mastering with editing of aux and system information, and the professional audio and video version with editing and cueing facilities.

In general, recording or playback can be done from either the DCC recorder or direct to or from the hard disk from analog or digital inputs and outputs.

The system provides for the cueing and editing of audio data, as well as system and auxiliary data, in the DCC format which uses the PASC (Precision Adaptive Coding) bit-rate reduction algorithm. Individual tracks or parts of tracks can be cut-and-pasted.

"The edit and cueing accuracy is 8 Msec, the size of the DCC block," said Erik

Verspeek, customer support manager, Philips Key Modules Group. "But with the bit rate reduction, you can store more audio on the hard disk, about two hours on a 350 MB drive."

The jingle creation and playback software provides jingle editing, playlist creation, and automatic playback. The Workstation can be combined with Philips DCC In-Cassette duplicator for more playback machines.

"You have a small radio station right here," Verspeek said. "DCC is MPEG compatible. So another application would be digital radio."

## Built-in options

A built-in modem can be used for receiving DCC audio from the field and also for remote control of the playlist and sequencing. This can allow a person in a remote location to transmit an audio segment or program, and also insert it into the playlist and have it aired as well.

Future enhancements will include multichannel recording, mixing and cross-fading, connections to soundcards to obtain MIDI capabilities, higher downloading speeds of two, four, or eight

times to the In-Cassette Duplicator, and a Layer I-II-III converter card and modem that will allow sending sound files on ISDN or via standard 14.4 Kbaud modems.

The DCC mastering software allows the creation of the DCC cassette and text information. Another program reads and displays the text information present in either a CD or a DCC. Album titles, artist, song titles, lyrics, and production credits also can be displayed. In future versions, the text software could be used to interactively control DCC or CD machines in making selections.

William Lenihan, director of sales, Philips Key Modules Group, reported that some U.S. and European radio networks have expressed interest in a portable DCC unit that can be used in conjunction with the workstation. While a professional version of a field recorder is being considered by Philips, according to Lenihan, a consumer version, the DCC-170, will be available this summer.

In addition to being an audio record and playback system, Philips envisions DCC will be used as a computer peripheral providing low-cost mass data storage.

Philips has developed other products that

are designed to support DCC audio systems. One is the Sound Enhancer, a DSP-based processor that features scratch suppression (de-clicking) for vinyl record playback, stereo effect for mono recording, spatial effect for stereo recording, audio compression and expansion, Authentic bit imaging, bass, treble, and balance controls, fader, sample rate converter, bitstream conversion D/A chip, and high quality A/D converter. Both a consumer and professional version will be offered, with the professional version available to OEM manufacturers in June 1994.

## Using DSP

The DSP technology used in the Sound Enhancer is based upon the Philips's research in psychoacoustics that resulted in the development of the PASC bit-rate reduction.

Philips will also sell the sample rate converter as a stand-alone unit. The unit has a selection of three output sampling frequencies, 32 kHz, 44.1 kHz, or 48 kHz. The input frequency range is dependent upon the output frequency selected. Again both a consumer and professional version will be offered with the professional version having full support of subcode handling.

According to Middeljans, Philips's ultimate goal is to have the sample rate converter and sound enhancer on a single chip.

Expanding its applications for its DSP technology, Philips is marketing a digital loudspeaker system concept, an active powered loudspeaker with digital inputs and digital signal processing for shaping the sound and providing acoustical corrections for the drivers. Future versions are expected to have an acoustic analyzer coupled with the DSP to provide corrections for particular rooms. A digital audio and control bus (single cable) will enable many configurations and control options.

"Philips is offering this to the industry," Middeljans said. "The OEM selects the speakers and housing, maybe Philips units, maybe his own. Philips opens up its labs and gives complete support to obtain the best acoustical combination of housing and speakers."

# PRC Examines Digital Trends

► continued from previous page

Radio, Alaska Public Radio, Hispanics in Public Radio and Blacks in Public Radio, met to discuss mutual interests.

National Public Radio and American Public Radio offered workshops, lectures and round table discussions. Bob Edwards, host of NPR's Morning Edition, presided over a forum delivery and interviewing workshop; American Public Radio's Ken Mills, director of news; Bruce Teriault, senior vice president and director of network operations, and Melinda Ward, senior vice president, cultural programming, paneled a discussion about multicultural programming in public radio.

A voice coaching workshop with Marilyn Pittman, trainer, offered breathing exercises, vocal projection and mic techniques. Other panelists from NPR included: Bill Buzenberg, vice president of news; Sandra Rattley-Lewis, vice president of cultural programming; and Donna Limerick, senior producer and hostess of "Horizons."

The quality and quantity of telecommunication information offered placed many participants in the unenviable position of having to choose between more than one event taking place during the same time slot.

Former Apollo XI astronaut Buzz Aldrin was one of the invited guests on "Tech Nation—Americans and Technology," a live broadcast in association with KQED-FM, San Francisco, with host Dr. Moira Gunn. Aldrin's appearance celebrated the 25th anniversary of the moon landing.

"NASA's space program has led to the vast array of satellite communications available today," he said.

Engineers had the opportunity to meet with experts in digital field recording, datacasting, RF delivery systems, radio frequency radiation compliance and cable carriage.

American Public Radio timed the con-

ference to publicize their name change from APR to Public Radio International (PRI). The network also announced plans to launch an international news program titled, "A New World." Produced in cooperation with the British Broadcasting Corporation (BBC) World Service, "A New World" will broadcast weekdays from the States and England. The program will incorporate live news coverage worldwide.

One large area at the Marriott was devoted exclusively to programming and product exhibits. Networks displaying information included United Nations Radio, Monitor Radio, Radio

Smithsonian, Pacifica Radio, Virtual Radio, Minnesota Public Radio, the BBC and Radio Finland. Organizations such as the Association of Independents in Radio (AIR) were also represented.

Some of the product exhibitors included Micro Technology Unlimited (MTU), a company in Raleigh, N.C., which displayed its digital audio workstation for a hands-on experience in the state-of-the-art editing. Their products are compatible with IBM personal computers.

WSC in Tampa, Fla., presented two programs for Macintosh users: Underwriter, to help track radio and TV accounts receivable; and RMP, to access, prepare or report virtually any information in a music library.

## On Target.

Performance, value, and reliability through innovative technology.

5 models available.

- BC6DSL
- BC6DSR
- BC8DSL
- BC8DSR
- BC12DSL

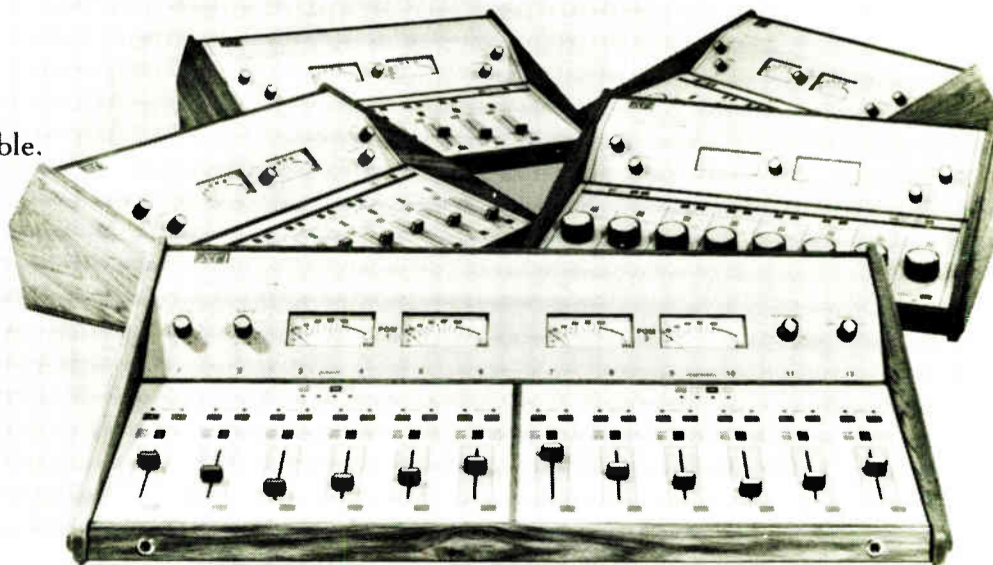

**ATJ** AUDIO TECHNOLOGIES INCORPORATED

Call or write for free detailed brochure.

328 W. Maple Ave. Horsham, PA 19044, USA  
(215) 443-0330 FAX: (215) 443-0394

# New NPR President Outlines Goals

by Elmer Barney

**SAN ANTONIO, Texas** "I've had over 20 years of experience in telecommunications, but I must admit that I'm new to the radio business," said Delano Lewis, the new president of National Public Radio, in an interview with **RW** during the Public Radio Conference last month.

Most recently, he served as the CEO of C & P Telephone Co., (a former Bell Atlantic subsidiary), a post held since 1990. He was offered the position at NPR from an executive headhunting organization.

"I was nearing the age of 55, and I thought it might be a good time to leave. NPR sounded exciting and challenging," he said.

National Public Radio is headquartered in a brand new building in Washington, D.C., at 635 Massachusetts Ave., and Lewis is excited about the facility.

"With the advent of a new building and the fact that I was new and the newness of technologies that are emerging, I thought this is a good time to take a look at NPR, a very solid fundamental look. Not only is it needed, but I also felt it would be a good time for me to learn and get a feel for this organization, so I hired a facilitator."

Michael Gelb, Lewis's friend and colleague at Bell Atlantic, is helping with an overall evaluation of NPR.

"Michael is a trainer, a special consultant in building teams and helping teams develop high performance attitudes and techniques. I sat with him and said, 'Look, I want you to come and help us. You can't charge what you used to charge me when I was in a profit-making group. I'm with a nonprofit group today.'"

The two immediately sent out memos to all NPR employees asking for their input and asking questions, Lewis explained.

"We received hundreds of pieces of mail and messages with ideas about

NPR," Lewis said. "We're taking those ideas to our senior management retreats. The whole idea of the retreat with the senior team is to get us thinking alike, not uniformly, the same mission and purpose, and taking input from the employees to begin to fashion this vision."

"We are facing some very critical issues in our society today," Lewis said. "How do they impact public radio? I believe that NPR is a solid educational institution as well as an information and entertainment facility. Our purpose is to act in the



NPR President Delano Lewis

public interest, to look at issues and events and not be influenced by commercial activity but in a non-commercial way."

He continued: "We're going to use technologies we have to get that information out to the broadest segment of people and hopefully it will stimulate them to think, and that's a real good value in this

country. If we're lucky, we will get them to act. Now I'm not saying that's the kind of tool we're going to be, but I think that's the role we must play. I think public radio has an absolute obligation to play that role."

In addressing listenership, radio audiences and funding for the programs, Lewis said, "We want to capitalize on our strong news programs and news magazines while increasing minority audiences. What we do is in the public interest, so again, we have an obligation

to air diverse points of view. We took a survey of our listenership, and the results showed that one third of our listeners are liberal, one third are conservative and one third are moderate or whatever, so our listenership spans the spectrum."

"Funding is not an easy task," Lewis added. "There are certain members of our legislative body that believe the public should not fund public radio, that it should be on its own. There are others who really support us. Senator Ted Stevens of Alaska believes public radio serves a valid purpose and is a lifeline for his constituents."

Lewis took a few moments to clear up some misconceptions about public radio funding. "NPR is not totally funded by the federal government. Only about 3 percent of our revenue comes directly from the federal government. I want to make NPR less dependent on government funding. In order to do that, we must find new revenue streams, find ways to attract more corporate and

foundation funding and continue to fulfill our role as a content provider."

Lewis continued: "I have to raise about one third of my \$46 million budget. I get about \$30 million or so from our 500 member stations for the programming we provide for them, so fund-raising is a big job."

Jerry Jacob, the general manager of

**"I want to make NPR less dependent on government funding. In order to do that we must find new revenue streams."**

—Delano Lewis  
NPR President

KALW-FM in San Francisco said, "We're an industry of survivors that needs to turn into an industry of winners."

"From where I stand as president of National Public Radio, I like to say, we not only want to survive. We want to grow and prosper. Lewis said in response to Jacob's comment. So I don't view my leadership as just one of survival mentality. I view us as being in a growth mode. Less than six percent of people listen to public radio. Ninety-four percent do not. You can look on that as a real disaster, but I look upon it as a growth opportunity. Look how far we can grow"

Lewis smiled broadly as he continued. "There's a lot to do here. We want to build on our strength. I'm not about the business of looking at this in a negative way. We've got a strong product and a good reputation.

"We've got quality programming, and I want to take that, not only to grow in the United States but overseas as well. We're taking 'Morning Edition' and 'All Things Considered,' real time, to Europe and Eastern Europe. I think that's the direction we should go, and I'm excited about it."

Del Lewis also is wearing another hat these days. He's just been appointed co-chair of the National Information Infrastructure Superhighway, along with Edward McCracken of Silicon Graphics in San Jose, Calif. The two were appointed to the positions by Secretary of Commerce Ron Brown.

Lewis talked about some of their plans. "One of the things we're going to be doing is giving advice to the Clinton administration on this communications highway. Now, I'm excited because not only is this the hottest issue in the country, but I'm excited in terms of what it means for public radio and public broadcasting, the fact that we act in the public interest. I want to add value to whatever emerges on this superhighway."

As for the future of NPR, "I think that our opportunities are unlimited. I think that our spirit is still bright and that we're going to live on, hopefully in good health, for a number of years to come," he said.

During the final night of the PRC, there was a talent show for the participants. Del Lewis came out on stage and did a soft shoe routine that brought the house down. He's energetic. He's decisive and he certainly knows how to capture and hold an audience.

**If You Think We Only Supply Cable Harnesses ...**



**Think Again.**

You should see the quality and pricing on Clark Wire & Cable bulk cable and connectors.

**CLARK WIRE & CABLE**

Clark Wire & Cable has industry standard audio and video cables available in as many as ten jacket colors. Our customized A/V cables are designed with your needs (and pocketbook!) in mind.

**1-800-CABLE-IT!**  
151 S. Pfingsten Road #B  
Deerfield, IL 60015

**If You Think We Only Supply Bulk A/V Cables ...**



**Think Again.**

Clark Wire & Cable provides custom high quality cables, cut to length and terminated to your specifications.

- Patch Cords
- ADAT Harnesses
- DA-88 Harnesses
- DT-12 Audio Snakes/Harnesses
- RGB Cables
- Remote Camera Cables
- Digital A/V Assemblies
- Complete Facilities
- And More!

**CLARK WIRE & CABLE**

**1-800-CABLE-IT!**  
151 S. Pfingsten Road #B  
Deerfield, IL 60015



# Satellite DAR Services Not on 'Fast Track'

by Alan Haber

**WASHINGTON** The Federal Communications Commission (FCC) is currently reviewing applications it has received from four companies proposing satellite digital audio broadcasting services. Objections voiced by the National Association of Broadcasters (NAB), which may hold up the FCC process, may assure that satellite DAB will not become part of the association's diet anytime soon.

"We are less than thrilled with (satellite DAB)," said Barry Umansky, NAB's deputy general counsel. "NAB has steadfastly opposed the entire notion of satellite delivered audio provided directly to listeners."

"We find that it is completely at odds with the most fundamental concepts of local broadcast service and the foundations of broadcasting as set forth in the communications act."

## NAB opposition

Umansky added that opposition to satellite DAB "is perhaps the highest priority among the radio issues being addressed at the NAB." (The NAB has taken a definite proactive stance on terrestrial digital audio broadcasting with its support of In-band, On-Channel (IBOC) technology that currently is being tested, along with other systems, in Cleveland.)

Gary J. Shapiro, group vice president of the Electronic Industries Association's Consumer Electronics Group, predictably feels differently about the satellite issue.

**"Enhancements in technology cannot be stifled to protect existing interests. Existing interests must show flexibility in adapting to the new technology."**

—Gary Shapiro  
Electronic Industries Association

"Enhancements in technology cannot be stifled to protect existing interests," he said. "Existing interests must show flexibility in adapting to the new technologies."

Bill Caldwell, president of Digital Satellite Broadcasting Corporation (DSBC), one of the four companies proposing satellite DAB services with applications pending at the FCC, said he believes the NAB's objections amount to "a scare tactic."

"When you really look at the NAB," he said, "they have resisted every new technology and new system over time, and in reality they should really try to embrace this system. What they really are doing is providing a disservice to the public by not bringing radio into the 20th century via digital."

Activity was initiated in the satellite DAB arena when the FCC issued a notice of proposed rule making in

1992. Six companies applied at that time; four now remain: American Mobile Radio Corporation, CD Radio, DSBC, and Primosphere Limited Partnership.

Even though the notice of proposed rule making to reallocate proposed frequencies for satellite DAB has not yet been finalized, a motion for negotiated rulemaking has been filed.

According to an FCC spokesperson, the four applicants have indicated they are trying to work out a frequency sharing plan that will allow them to share the 50 MHz of spectrum involved; if the

applicants cannot come to an agreement, the FCC might step in and make a decision. The spokesperson added that there is no FCC timetable for FCC decision making at this time.

## New services

The subject of satellite DAB was prominently raised during the "FCC Regulatory Dialogue" session at NAB '94 in Las Vegas.

During the session, which touched on a variety of issues, Roy J. Stewart, chief of the FCC's Mass Media Bureau, said he didn't think that, at the present time, he

would call satellite DAB "a front burner issue." Noting his feeling, however, that "the commission is charged with the responsibility to encourage the provision of new technological services," he said that "the commission cannot stand up and say there will be no satellite digital audio broadcasting."

During the panel, an audience member commented that he thought the satellite question was really one of "a revolutionary revision of the communications act".

He suggested that if satellite DAB is authorized, it would siphon "a substantial

continued on page 16 ▶

## AN EXCLUSIVE EVENT.

GOLDEN SERIES

Precious TOOLS

There are moments in the course of a manufacturing Company's life that become historical milestones, not only for the Company itself, but for the whole industry. EXCLUSIVE FM, AEV's newest FM broadcasting processor, represents one of such milestones. It's an event. A truly extraordinary event, setting a faster pace in the evolution of FM broadcasting. To emphasize only some of EXCLUSIVE FM's features would be like diminishing it. AEV is pleased to invite Radio and TV Broadcasters the world over to contact its Dealers for detailed information, as well as to verify, in the course of a hands-on demonstration, the meaning of the word "extraordinary".

AEV ELECTRONIC BROADCAST EQUIPMENT

Phone 39 + 51 + 950249 / 950350 Fax 950201

## COLE'S LAW

# FCC to Examine EEO Reform

by Harry Cole

**WASHINGTON** There have been a few developments at the FCC recently that touch on topics of "Cole's Law" columns in the past few months, so find some white-out and sharpened pencils to mark in these updates.

First, only two months after approving new fines and forfeitures for Equal Employment Opportunity (EEO) violations

(RW, April 20), the commission opened a general inquiry into "the effectiveness of its [EEO] rules, procedures, policies, standards and guidelines."

Also, there has been a little confusion about the deadline for conformance to the commission's AM emission standard. For practical purposes, stations should now consider June 29, 1994, as the deadline.

No due dates have been

announced for the FCC's EEO inquiry, but the commission will need them in time to write a report to Congress that is due this October.

The commission is looking for comments on "possible improvements to the EEO rules, policies and enforcement thereof; and on how to further, to the greatest extent possible, the goals of the commission." It is looking particularly for "ways to better enable

broadcasters to meet their EEO obligations."

There will likely be questions on how stations in small markets can comply with the rules, despite historical difficulties in attracting and retaining minority employees. The commission will also ask whether part-time hires should be eliminated from the regulatory process.

These seem to be relatively benign topics, but they do raise the question: If the FCC acknowledges that these questions exist, why did it just announce a new fine/forfeiture schedule that includes serious penalties for fail-

ure to comply with these rules?

A perhaps more ominous puzzle is the commission's request for comments on "whether broadcasters should be required to encourage minority and female entrepreneurs to conduct business with all parts of their operation."

What does this mean? Is the FCC heading toward some kind of affirmative action set-aside system in which broadcasters must demonstrate that they "encourage minority and female entrepreneurs" to "conduct business" with them?

We will have to wait to find out exactly what the FCC is proposing, but the early indications raise some concerns. It is difficult to swallow the notion that the FCC can intrude itself into a station's minute day-to-day business decisions.

I originally reported (RW, March 23) that, starting July 1, 1994, AM licensees would be required to perform measurements at least once every 14 months to assure compliance with the FCC's new emission standard (Section 73.1590(a)(6)).

Since then, the FCC has issued a public notice announcing that licensees must resume their annual schedule of emission measurements before or by June 30, 1994. The notice's exact wording is:

[Affected licensees] are reminded that they must resume an annual schedule of measuring their emitted spectra before June 30, 1994. As a result of the 73.44(e) temporary waiver period coming to an end, each station that has not been making measurements must do so by June 30, 1994, to comply with 73.1590(a)(6).

So there appear to be three possible deadlines: the July 1 deadline that I originally read into the rule, and the notice's *before* June 30 and *by* June 30.

Frankly, I am not sure which is legally correct. I will concede in good lawyerly fashion, however, that I read the rule incorrectly, and that you should probably not rely on July 1.

As far as picking between "before" and "by" June 30, certainly the safest course would be to go with the earlier deadline so that there is no way you could be accused of a violation. It is a difference of only one day, so it will probably not significantly increase the burden.

Be advised that the FCC does not intend to extend the "presumptive compliance." The commission may grant individual waivers upon a showing of good cause, but the most recent public notice suggests that waivers will be hard to get. The better approach is to grit your teeth and start measuring on or before June 29.

□ □ □

Harry Cole is a partner in the Washington-based law firm of Bechtel & Cole, Chartered. He can be reached at 202-833-4190.

# Miles Above Your Competition!



As authorized distributors for multiple lines of satellite communications products, we'll make sure you have the right system for your needs. Then we'll handle the implementation details: from licensing & lease financing; satellite selection & space segment; to turnkey installation & training. But we don't stop there—NSN maintains a 24-hour Technical Support Center because your network doesn't stand still after five.

Experience and service is why NSN Network Services is the nation's leading distributor of SCPC digital VSAT audio and data networks.

Look to us for:

- ☞ *Audio & Data VSAT Network Equipment*
- ☞ *VSAT Network Design*
- ☞ *Domestic & International Spacetime*
- ☞ *Integrated Operations Networks*
- ☞ *24-Hour Technical Support*
- ☞ *Installation & Training*
- ☞ *Disaster Recovery*
- ☞ *Lease Financing*

**P**ut yourself above the rest with a satellite system from NSN Network Services. NSN's digital VSAT audio and data distribution systems have enabled broadcasters around the world to reach new heights in program and spot distribution, while keeping costs grounded.

If you want to program distant stations, centralize commercial production and billing, start your own programming network, or expand your existing operation, call us. NSN has established and supports over 60 digital satellite audio systems, with over 1,000 receive sites worldwide.

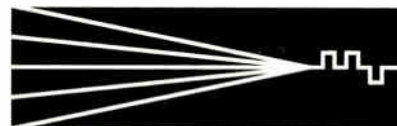

**NSN NETWORK  
SERVICES**

SM  
Avon, Colorado USA

303♦949♦7774

800♦345♦VSAT  
8728

Fax 303♦949♦9620

NSN is an authorized distributor of ComStream, Gilat, Audisk, Crown, and other fine satellite and broadcast communications products.

**Audiences *never* age.**

**Music *never* changes.**

**Formats *always* stay the same.**

**And Digital is *just* a passing phase.**



*The Optimod-FM 8200 Processor*

**Damn.**

We created the first successful all-digital sound processor to give FM stations absolute flexibility. Be able to adapt to new music, personalities, or formats. Tailor sound to attract new audiences. And have the ability to upgrade with simple, inexpensive software—instead of tossing out an entire capital investment.

Somehow, that makes a lot more sense to us than trying to compete in today's radio market with outdated analog technology. But we could be wrong. Dead wrong. After all, digital could be just a passing phase. Elvis could really be living in Cincinnati. And WKRP could be the future. Damn.

**orban®**

**H** A Harman International Company

1525 Alvarado St., San Leandro, CA 94577 USA Phone 1•510•351•3500 Fax 1•510•351•0500.  
© 1994 AKG Acoustics, Inc. Orban and OPTIMOD are registered trademarks of AKG Acoustics, Inc. All other trademarks are property of their respective companies.

Circle (146) On Reader Service Card  
World Radio History

# Harrisburg Pranksters Test Modern Home Appliances

Dear Luci,

Please don't be too dismayed, but as WNNK-FM reported last month, I got flattened by a microwave oven dropped off the roof of a high-rise office complex in downtown Harrisburg, Pa.

The good news is that it was an April Fools' Day bit.

Our morning team of Tim Burns and Sue Campbell decided to revive the classic National Lampoon "Catch-It-and-You-Keep-It" routine from the "Radio Dinner"

album. Contestants stand at street level and catch prizes tossed over the parapet.

Losers get pancaked by things like suit cases filled with gold bars and a 46-ton house. In my case, I "went" after the Panasonic microwave oven.

Good planning and good acting made the joke work. The emcee of our game really was up on our roof, prompting and coaching the "crowd" borrowed from the sales, news, programming and research departments.

## FROM THE TRENCHES

by Alan Peterson



The routine was recorded on March 31 using a single-point mic into a cassette deck for a truly genuine remote sound. Post sweetening was unnecessary thanks to nearby truck and rail traffic.

You want acting? The shrieks and screams that went up after my demise were perfect.

We knew the joke worked when angry phone calls began coming in from the usual contest moochers. Some had actually dragged their kids down to the contest site (some still in their jammies) only to find no crowd and no prizes.

Every year we ask ourselves the same question: Don't listeners look at their calendars?

They always seem ready to fend off the office bozo when they see April 1 roll around, but they can't anticipate a wacky morning team getting in on the fun. After a few years, you would expect them to say to themselves, "Uh, oh...What's gonna be on the show tomorrow?"

Sometimes the fun is spoiled by the dummies who deliberately give timechecks an hour late all morning, call listeners with some bogus disaster story involving a relative or cause panic with an all-too-real sounding emergency alert, complete with EBS tones. These are not April Fools' jokes; they are invitations to a license revocation.

A good gag stays within the bounds. Some of them achieve legendary status. Bob Steele, former mainstay morning man at WTIC-FM Hartford, Conn., did a "This-Is-My-Last-Day" routine every April 1 for several decades.

Two New York City radio stations once swapped feeds to their respective transmitters and broadcast the other station on their frequency.

Countless stations across the country "sponsor" a parade down their own Main Street using nothing more than creative sound effects, remote mics and plenty of march records.

The morning guy at a Harrisburg station across town tried to make his listeners believe the Beatles were reuniting and that Harrisburg was the first tour stop (not terribly likely). Old news audio and limousine reports courtesy of the station's traffic reporter made it sound plausible.

The best kind of April Fools' zinger is the one that boomerangs back on the person getting zinged (the zingee?) and leaves him standing speechless. For my money, the best zinger of them all was pulled off by The Real Bob James, the same man who put the American Comedy Network on-line and made a name for himself on WGAR-FM and WNBC(AM) (now WFAN(AM)).

James did the "This-Is-My-Last-Day" bit one April 1 while working for WRKI-FM Brookfield, Conn. Most listeners did not feel the zing until the next morning and James really was gone. He left to enter politics and to concentrate more on consulting.

So now we at WINK-104 are left with the task of topping this year's bit next April 1. Fortunately, there are 11 months left to work on it.

—Al

## THE DIFFERENCE IN SPECTRAL PURITY IS UNCANNY.

*Skip Camo, Group Engineer, WRZE, Havana, ALA*

Both systems were a breeze to install and they work great on our paths.

*Craig Bortone, Director of Engineering, Logan Broadcasting, WIII, Concord Rapids, MI  
WJQF, Dayton, OH*

The management says they can't believe how much better it sounds.

*Mario Heib, Chief Engineer, KXRK, Salt Lake City, UT*

It's the most transparent STL we've ever used.

*Don Ford, Director of Engineering, KACV, Amarillo, TX*

THE SONIC CLARITY OF THIS DSTL IS UNBELIEVABLE.

*Grady Moates, Consulting Engineer, WWKX, Providence, RI*

We were able to do our

46.5 mile link in one hop

with the added bonus of

the best stereo separation

and sound we've ever had.

It's perfection!

*Lyle Henry, Director of Engineering, KUSC, Los Angeles, CA*

*Michael Bradford, Consulting Engineer, WUPS, Mt. Pleasant/Houghton Lake, MI*

YOUR BOX IS A BOLT-IN CURE-ALL.

*Ed Simmer, Chief Engineer, WSAE, Springfield, MI*

We'll also be glad to quote you on a new STL.

Dolby DSTL users are awed by the difference it has made to their stations. It has not only improved their RF performance, but its punchy, dynamic sound has grabbed the ear of management and programming alike. No wonder the Dolby DSTL Digital Studio-to-Transmitter Link has become the new standard in STL quality.



Dolby Laboratories Inc., • 100 Potrero Avenue, San Francisco, CA 94103-4813 • Telephone 415-558-0200 • Facsimile 415-863-1373 • Telex 34409  
Dolby Laboratories Inc., • Wootton Bassett • Wiltshire SN4 8QJ • England • Telephone 0793 842100 • Facsimile 0793 842101 • Telex 44849  
Dolby, DSTL, and the double-D symbol are trademarks of Dolby Laboratories Licensing Corporation © 1993/Dolby Laboratories Inc. 933/9842/9981

Alan Peterson writes from Harrisburg's WNNK-FM, which was recently recognized as the highest-rated CHR station in America's Top 100 markets. Call him at 717-238-1041.

STATION SKETCHES

# Multitone Aids On-Air Audio Tests

by Tom Vernon

Part I of III

**HARRISBURG, Pa.** Many engineers have a hard time scheduling audio equipment tests in the air chain. Ratings sweeps are almost continuous in some markets, and access to key equipment is almost impossible, even when proofs are due.

At the same time, the demand for high-quality audio has never been greater. Audio testing is time-consuming and labor-intensive work even if access to all the equipment is available, especially when evaluating telephone lines or STLs.

What is a frustrated engineer to do? The new multitone audio testing technology, which has emerged over the past three years, simultaneously tests for frequency and phase response and noise distortion in a second or less, as accurately or better than conventional methods.

The RC audio oscillator, voltmeter and distortion meter have been the standard

for printout. Standardized tone sequences, such as CCITT 0.33, provide comprehensive testing, but require 30-32 seconds. In-service test sequences last about five seconds.

More elaborate systems with PC control are now used when an entire network is evaluated with a single transmitter and multiple receivers. Sequential tone systems may be used for bench testing of equipment as well.

Multitone testing improves the process. A group of tones is transmitted simultaneously. Each tone is carefully selected for amplitude, phase and frequency and to avoid mathematically predictable harmonic

and intermodulation products. Multitone testing is a nearly unobtrusive

Figure 2.

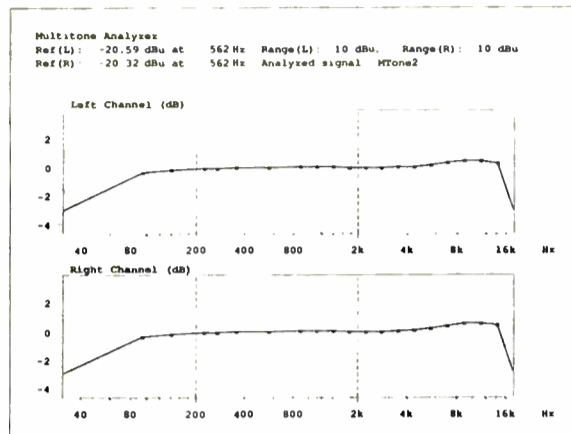

Multitone technology makes fast work of frequency response measurements. Courtesy of Tektronix.

Figure 1.

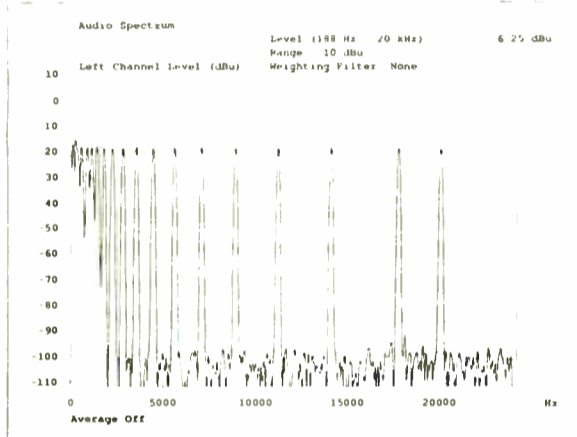

The fundamental frequencies of a multitone signal are shown in this audio spectrum display. Courtesy of Tektronix.

audio testing tools since radio's earliest days. Tubes begot transistors, which gave way to integrated circuits, but the techniques are virtually unchanged. Sine waves are easy to generate and measure, but make comprehensive testing time consuming.

**Different responses**

Some savvy engineers eventually realized that equipment responds differently to program material than to sine waves, which only simulate one portion of the audio spectrum. They began using pink and white noise to measure, which allowed them to test and observe the entire spectrum simultaneously with an octave band or spectrum analyzer.

But these tests lacked the precise resolution of discrete tone tests. Low frequencies can be measured +/- 2 dB, highs within a half dB, making it unusable for equipment noise or distortion evaluation.

Noise is a valuable tool for adjusting head azimuth in tape machines, separation and crosstalk tests, acoustic measurements and other assessments. Many engineers use a combination of discrete tones and noise to thoroughly assess their equipment.

Sequential tone systems were later developed to save testing time. A generator at the studio sends a preamble signal, a sequence of audio tones, down the line to a receiver, which evaluates and stores data

and intermodulation products.

**DSP technology**

The receiver, which employs recently developed DSP technology, detects any changes in amplitude, phase or frequency relationships. New frequencies, for example, are caused by noise or distortion. Phase relationship changes indicate phase response and changes in the amplitude measure the frequency response.

Figure 1 shows a typical spectral display of a multitone signal. By generating a multitone burst of a second or less, audio quality

audio evaluation system, roughly equivalent to the VITS signal video engineers use to evaluate critical parameters during regular programming.

Multitone test equipment has been widely available for about three years, but the techniques have been known for much longer. One equipment manufacturer was offering analog multitone equipment about 10 years ago, with 17 RC oscillators and 17 bandpass filters. The signal generator was good, but its analog filtering technology was unreliable and cumbersome.

Output from a modern multitone test system is read on a high-resolution display screen or printer. Information is updated about eight times per second. Graphs include level versus frequency, level difference between channels, phase difference between channels versus frequency and noise and/or distortion versus frequency.

continued on page 21 ▶

## RADIO STATION AUTOMATION for under \$5,000 !!

- Automate your audio for overnight or weekend broadcasts
- EBS Capable
- Low Cost 24 Hr Operation
- 16 Device Control - Expandable to 128
- Modular Design - Easy to use
- Use Existing Equipment
- Dependable Results

**Start Saving Today !**

**BROADCAST AUTOMATION**  
**100 Edgewood Street, Alexandria, TN 37012**  
**(800) 874-9629 (615) 529-2650**



**Svetlana**  
 ELECTRON DEVICES

**Quality\***  
**Power Tubes**

- 3CX15,000A7
- 3CX10,000A7
- 3CX3000A7
- 3CX3000F7
- 3CX2500F3
- 3CX2500A3
- 3CX2500H3
- YC130
- 4CX15,000A
- 4CX10,000D
- 4CX5000A
- 4CX5000R
- 4CX3500A
- 4CX1500A
- 4CX350A
- 4CX350AC
- 4CX250B
- 4CX250BC
- 4CX250R
- 4X150A
- 5CX1500A
- 5CX1500B
- 811A
- 813
- 833A
- 8560AS

- Watch this list grow.
- Manufactured in Russia's largest power tube factory.
- Generous\* warranty based on high quality.
- Honest prices based on quality at low cost.
- Shipment from USA stock.



**Svetlana**  
 ELECTRON DEVICES

**Broadcasters**  
 Call: 800-239-6900  
 FAX: 205-880-8077

**OEMs, Distributors, Volume Purchasers**  
 Call: 415-233-0429  
 FAX: 415-233-0439

invented the DigiCart<sup>®</sup> recorder to bring CD quality audio to broadcasting. Our on-going technical efforts provide customers with the service, upgrades and confidence expected in the broadcast community.

360



DIGICART/II

# DIGICART/II

## THE PROVEN UPGRADE FROM ANALOG CARTS

### STANDARD FEATURES

- Instant access to any of 10,000 cuts
- 2-hour internal hard disk
- 68-minute Bernoulli cartridge drive<sup>2</sup>
- 16-bit linear recording for true CD quality
- Selectable Dolby AC-2 Data Reduction<sup>1</sup>
- Normal operation provides 20 kHz stereo audio
- Digital Editing
- DSP generated fades & levels changes
- Bright 40-character display shows cut name, ID#, running time, and helpful user prompts
- Pre-program breaks and spot rotation
- Automatic record-on-audio
- Five year hard drive warranty
- Five year Bernoulli disk life
- Worldwide sales and service

### BREAKTHROUGH PRICING

- Only \$4,995 record/play stereo, including a 2-hour hard disk. Other models from \$4,250 less hard disk. DigiCart/II is by far the lowest priced digital cart recorder on the market.
- Low-cost media—Only \$1.42 per minute<sup>2</sup>

### OPTIONAL FEATURES

- Mini keyboard for titling and remote control
- Two new remote controls include LCD display
- "Hot Keys" give instant access to 16 spots
- Larger hard disks store 4 or 8 hours of stereo
- External hard disk arrays store up to 48 hours
- AES/EBU and SPDIF digital I/O<sup>3</sup>
- Toolkit for developing custom serial port programs

FOR A FREE 12-PAGE BROCHURE, CALL 818.342.3127

360 Systems

PROFESSIONAL DIGITAL AUDIO

360 SYSTEMS 18740 OXNARD STREET, TARZANA, CALIFORNIA 91356 818.342.3127 FAX 818.342.4372

DigiCart/II

<sup>1</sup>User-selectable. <sup>2</sup>150 MB Bernoulli Disk. <sup>3</sup>SMPT/EBU Time Code board and Digital I/O available 1994. Stated specifications are with Dolby AC-2 operation.

DIGICART IS A REGISTERED TRADEMARK OF 360 SYSTEMS. DOLBY IS A TRADEMARK OF DOLBY LABORATORIES, INC. ©1993 360 SYSTEMS

World Radio History

# Transistors Allow High-Current Flow Control

This revised course offers an introduction to the theory and practical application of active electronic devices. The course will give examples of how the devices work as well as ideas on how to use them.

Continuing Education Units will be offered to all who register with Northern Virginia Community College. You will be required to read all of the articles and participate in an exam that will be mailed to you at the completion of the course. You can register for the class any time while the series is running in RW.

To register, contact the Community Education Office, Annandale Campus, 8333 Little River Turnpike, Annandale, Va. 22003. The fee for the course is \$30.

Please make every effort to secure all of the articles yourself. Northern Virginia Community College and RW are not in a position to supply readers with back issues.

by Ed Montgomery

## Part X of XII

**ANNANDALE, Va.** The transistor was originally developed by AT&T to act as a remote switch, replacing energy-hungry vacuum tubes. It operates with a very small flow of current which can control a much higher current flow.

Depending on the transistor design, far greater current will flow from the emitter to the collector, when the emitter-base junction is forward-biased with a few microamps of current.

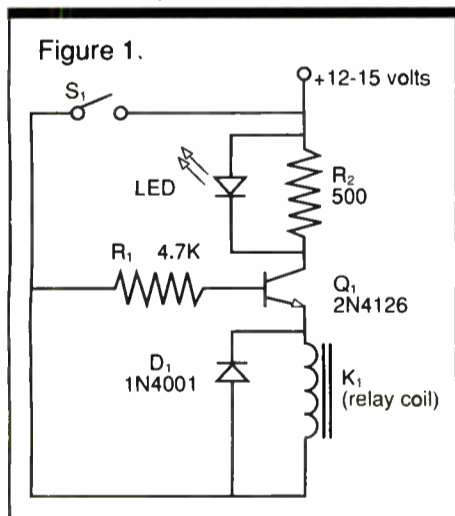

A transistor acting as a switch to control a much greater current flow is shown in Figure One. Current flows through R<sub>1</sub> when S<sub>1</sub> is closed. The transistor is forward-biased, which activates K<sub>1</sub> and permits current to flow. The relay contacts carry several amperes of current, while only microamps of current flow through S<sub>1</sub> and milliamps flow through the transistor.

This type of circuit applies when its controls can be mounted on a panel, and dangerous high voltage and current can be switched to a remote location. An LED indicator indicating whether the circuit is on or off can be added.

Transistors are mainly used to sense variations of current flow and amplification. Power supplies are important; the more sophisticated the equipment, the more precise the voltage supplied to the components must be.

The demand for voltage and current

constantly changes, which can distort signals in analog circuits and misrepresent signals in digital circuits. Voltage regulators using transistors adjust power for specific needs at specific times.

Figure Two shows a simple circuit to regulate voltage supplied by the diode rectifiers, and associated capacitors, resistors, and coils that provide a pulse-free direct current.

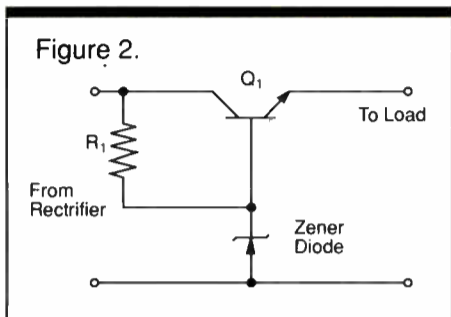

To properly regulate voltage, a power supply must provide a higher voltage than required by the electronic equipment it operates. The zener diode establishes the voltage level at the output of the supply. The power supply is connected in parallel with its load and the electronic components depend on it for electricity.

As the demand for electric current increases, voltage drops. The transistor injects more current into the circuit to keep the voltage up.

A series regulator, as shown in Figure Two, consists of two active devices, an NPN transistor and a zener diode. Know how much power this regulator must deliver before building this type of circuit. The diode must draw some current to permit the transistor to operate.

R<sub>1</sub>'s current consists of the transistor base current and the zener current. It can be found using the formula:

$$R_1 = \frac{\text{Input Voltage} - \text{Zener Voltage}}{I_B + \text{Zener Current}}$$

The unregulated voltage should be one volt above the regulated output. The zener diode is connected in parallel with the load and the transistor is connected in series, operating in a linear manner.

(Engineers today do not have to build this circuit themselves. Regulators are manufactured containing both devices in a wide array of voltages.)

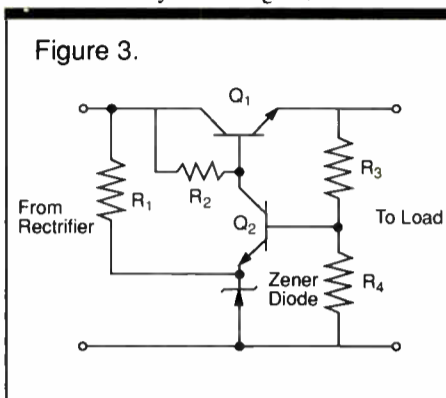

An improved version of the voltage regulator, as shown in Figure Three, connects Q<sub>2</sub> in series with the zener diode, establishing the output voltage.

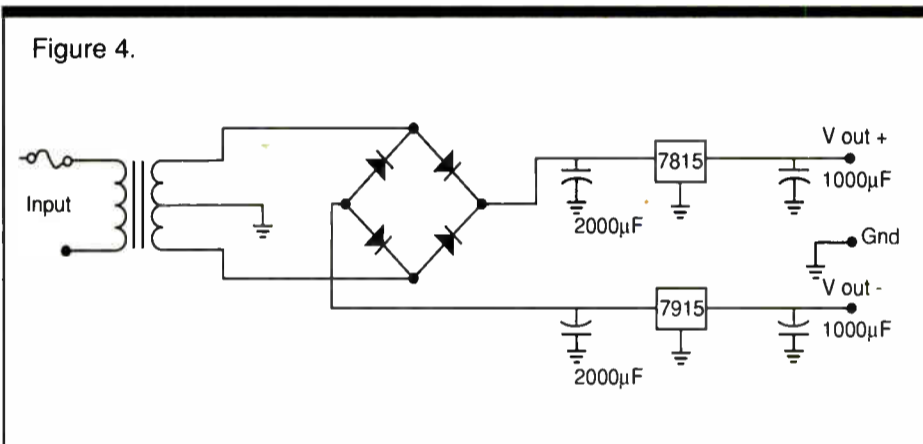

Q<sub>2</sub> is in parallel with the load in this circuit. Changes in input voltage or load voltage are sensed by Q<sub>2</sub>, which will adjust the bias voltage on Q<sub>1</sub> by

increasing or decreasing the current.

R<sub>4</sub> detects voltage changes in the output, resulting in adjustment of the bias of Q<sub>2</sub> which, in turn, adjusts the bias of Q<sub>1</sub>, increasing or decreasing the output current.

Power supply design has been simplified over the years. Figure Four shows a regulated supply with both positive and negative DC voltages. Most solid-state circuits require positive and negative source voltages. The 7815 and 7915 are +/- 15-volt regulators with one ampere ratings.

Know the correct voltage, current, and power dissipation requirements when building a power supply. Many electronics stores sell prepackaged power supplies that equal the cost incurred when building a home-made device.

Further information on power supply regulation and design is available in the "ARRL Handbook."

□ □ □

Ed Montgomery is a communications teacher at Thomas Jefferson High School for Science and Technology. He has taught broadcast engineering at

Northern Virginia Community College and worked as a broadcast engineer for several radio stations. He can be reached at 703-750-5090.

## This could be the last cassette deck you'll buy this century.

Since cassette decks are still standard equipment in any studio, it makes sense to turn to a deck that you can rely on both now and in the future: the TASCAM 112 MK II. Because even on the worst of days, the 112 MK II will be the one thing you can always depend on to work right. No prodding, kicks or angry swats needed.

Of course, the 112 MK II offers you key features like three locate points, cue and review and an optional easy-to-install kit for adding +4dBm balanced XLR inputs and outputs.

It's rugged. It's reliable.

It's powerful. What more could you ask for from a professional stereo cassette deck that takes its job just as seriously as you do — and is bent on outliving most of the other equipment that you

**TASCAM**  
Take advantage of our experience.

have in the studio. Pick up a 112 MK II today and make it the last deck you'll buy this side of the 20th century.



The popular 112 MK II, available with a balanced XLR input/output kit, is the industry's rugged and reliable cassette deck for broadcast and production studios.

# Satellite Digital Radio Services Before FCC

► continued from page 9

portion of the audiences, particularly in the small and medium-sized markets." He added that an insufficient audience base would therefore exist "to support the continuation of the local broadcast stations," and effectively eliminate, "to a large extent," local broadcasting.

Stewart responded by saying that, from the commission's point of view, "we can not stop technological development. It is not in the public interest...I don't think that there is anything in the constitution of the United States or the Communications Act that said that the commission shall not permit technological development, even if it

has an adverse effect on one aspect of the communications industry."

## The proposed systems

- American Mobile Radio Corporation's (AMRC) proposed system would make use of two satellites, the first of which would serve the contiguous United States, and the second which would serve CONUS, Alaska, Hawaii, Puerto Rico and the U.S. Virgin Islands. Satellite design is based on the Hughes HS 601 satellite.

- AMRC proposes to operate a single uplink facility for transmission to the two satellites, adding that its system "will support uplinks from additional earth stations

that might be used by entities leasing capacity on the AMRC system."

- Eleven CD-quality channels, five FM-quality stereo channels, five FM-quality mono channels and one data channel are proposed to be part of a primarily subscriber-based service (formats have not yet been chosen); a few free services supported by advertisers are also intended to be offered.

- CD Radio's proposed subscription-based service offers 30 channels of "commercial-free digital compact-disc-quality music," according to the company's prospectus. (Representatives of CD Radio were not available to speak with *RW*, as the company is now in a "quiet period.")

Up to 20 more channels consisting "of other formats that do not require compact-disc-quality fidelity, such as all-news, all-sports, and all-talk programming," may also be offered, according to the prospectus. A fee of \$10 or less is proposed.

Targeted to drivers of cars and trucks across the United States, the proposed service would be broadcast "via its own custom-designed and built twin-satellite system, utilizing technology developed by the Company," according to the prospectus.

CD Radio has an agreement with Space Systems/Loral, "pursuant to which Space Systems/Loral has agreed to construct the two satellites and, at the company's option, a third spare satellite," according to the prospectus.

- Digital Satellite Broadcasting Corporation (DSBC) has proposed a subscription-based service, and, according to president Bill Caldwell, "we also feel there will be a demand...for an advertising-based (service) as well."

DSBC's preferred satellite system configuration and signal processing scheme "employs both frequency division multiplexing (FDM) and spread spectrum modulation for beam isolation and

channelization," according to the company's FCC application.

The proposed frequency plan, according to the application, "coupled with the amount of power that the advanced design satellite can deliver, enables" the system "to be configured with a nationwide beam serving the 48 states (CONUS)" and 31 regional beams.

The application notes that "each regional beam in the CONUS covers an area at least 230 miles in diameter."

- Primosphere Limited Partnership has applied to the FCC "for authority to construct two satellites to operate in geostationary orbit," broadcasting 23 "near-CD quality music channels and up to six talk or other non-music channels," according to Primosphere's FCC application.

Programming would include six channels dedicated "to musical styles which reflect the richness of American heritage and which get little or no radio play time" today, including pre- and mid-1970s country and American Roots Rock, according to the company.

Primosphere is owned by Clifford Burnstein and Peter Mensch, who also manage rock groups such as Metallica and Def Leppard, and own radio stations in California.

## Coexistence?

EIA's Shapiro believes terrestrial and satellite broadcasting can indeed live side by side. "Smart local broadcasters," he said, "will learn how to make money by selling their services through the national broadcasters, just as smart local broadcasters now are selling their services into syndication."

AMRC's Levin also believes in the coexistence theory. "We have no expectation of competing with or replacing local broadcasters," he stated.

And DSBC's Caldwell pointed out that "a nationwide system will never be able to provide the type of service that a local station can provide to a very narrow geographic area."

## JOIN THE HUNDREDS WHO HAVE USED DIGILINK TO ACHIEVE ECONOMIC RECOVERY

- ☐ 10 hours of stereo digital audio storage for \$7,995\* complete
- ☐ Satellite, CD, Tape, and Hard Disk Automation
- ☐ Simultaneous Play, Record, & Network transfer
- ☐ Digital Editor with Waveform Editing for tight production
- ☐ Crossfade CD's, sources, and hard disk audio
- ☐ Music Scheduling system built in for basic CD automation
- ☐ Digital Networking for transfer of audio and schedules

Digilink is the #1 selling digital audio hard disk system in radio today. You can replace your cart machines for live On Air and have an automation system for walk away at the same time! Link over 15 workstations & scheduling computers on our digital network and transfer audio and schedules between your studios.

For more information, call or write  
ARRAKIS,

(303) 224-2248

the premier broadcast manufacturer of  
consoles, furniture, Digilink and Trak\*Star digital audio products.

Consoles  
Modulux  
Trak\*Star  
Digilink  
Modulink

## ARRAKIS

\* Suggested retail price. Complete system

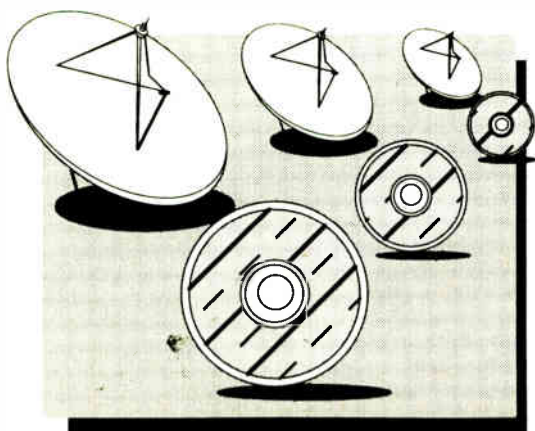

© 1993 Arrakis Systems inc. 2619 Midpoint Drive, Fort Collins, CO. 80525

Circle (123) On Reader Service Card

**BELAR**  
STEREO MONITOR

**You  
can measure...**

**with the best monitor and the most accurate test set.**

The FMM-2/FMS-2 series monitors provide an even greater degree of precision measurement than ever before... **You can measure S/N below 90 dB, You can measure crosstalk below 85 dB, You can measure separations of better than 70 dB, You can measure frequency response to better than 0.25 dB, You can measure distortions to lower than 0.01%, and much more...** Our uncluttered panels and autoranging voltmeters make these measurements a dream.

**BELAR** (610) 687-5550  
**ELECTRONICS LABORATORY, INC.**  
LANCASTER AVENUE AT DORSET, DEVON, PENNSYLVANIA 19333  
Call or write for more information on Belar AM, FM, Stereo, SCA and TV monitors.

World Radio History

Circle (34) On Reader Service Card



KEYBOARD CONNECTION

# Computers Let Radio Ride Highway

by Barry Mishkind

**TUCSON, Ariz.** As more computers are installed, the ability to gather and present information in a flash has made everything from talk-show call screening to transmitter control easier and more accurate. Storage and recall of information has become important for all departments.

Computers help build client leads, track music trends, store news archives and provide instant communication around the world. From CD-ROMs to electronic networks, the information superhighway is turning the corner.

**Short trips**

Extending the already well-worn analogy, think of your in-house computers as city streets, leading to nearby destinations: music and commercial scheduling; preparing letters and invoices to clients; logging the power output of the transmitter.

News/talk shows run on current information, which can be rapidly compiled using in-house computers with CD-ROM readers for reference software. Multimedia encyclopedias, like Microsoft's "Encarta," allow you to search an entire encyclopedia in seconds, and access complete information, including pictures and sound.

"USA Today, the '90s," from Compton's NewMedia, holds every issue from January 1990 to August 1992, with graphics, photos and over 100,000 articles on one disk.

Music should check out "The Grammy Awards," a listing of 34 years of Grammy Awards from 1958, including audio clips. "Jazz—A MultiMedia History," which traces jazz greats going back to 1923, is perfect for researching documentaries.

State highway systems connect small cities. They are sometimes pretty fast, but you do run into traffic lights and traffic jams.

Electronic mail is like that. You can dial into any of several networks, leave a message, and the recipient will see it a few seconds later—or, perhaps, several hours later.

Some businesses now consider standard mail an archaic waste of paper compared to e-mail and fax. They never lick stamps.

**Shortened trips**

The information superhighway is something else altogether. It links the nation from end to end without stoplights, like the Interstate Highway system. In fact, Internet system of computer networks links the entire world in real time. You can press a key from your desk and access a computer on the other side of the globe.

You can ask a colleague a question and have a reply in less time than it takes a phone call to get through. If he's not there, leave an e-mail message, and you'll be notified the instant he replies, if you are on-line at the time.

Could your sales or programming departments use some marketing statistics? They could access databases and files from universities, businesses and government agencies worldwide. There are also thousands of discussion groups, known as USENETs, that focus on every imaginable topic. (Broadcasters should look for rec.radio.broadcasting.)

Even the FCC has gotten into the act: ftp@ftp.fcc.gov is the address for all current FCC actions. Additional commission

data may eventually go on-line, depending on available resources.

Full access to the full potential of the superhighway can cost several thousands of dollars per month. Several companies provide dial-in access for hourly rates, while others charge flat rates.

**Feasible options**

The so-called FreeNets are an economical alternative. Anyone can access them without charge. Call the Cleveland Free-Net at 216-368-3888 for a free personal Internet account. Also try the Denver Free-Net at 303-270-4865. In Canada, the

National Capital Free-Net is at 613-780-3733. There are others.

Internet does not support the DOS your PC uses. It usually operates on UNIX or a UNIX/DOS cross called "Waffle," which has arcane help screens. This is an area where a good book saves time.

Gibbs & Smith's "Navigating the Internet" (Sams Publishing) is like an information superhighway road map. It shows the basic procedures for gaining access, and then guides the user, step-by-step through Internet so that you get to the "right address."

"Riding the Internet Highway" by Sharon

Fisher (New Riders Publishing) is a chatty book designed to help new Internet users maneuver through the maze of "side roads" and stay out of the electronic "ditch."

"The Electronic Traveller" by Elizabeth Crowe (Windcrest/McGraw-Hill) explains the wide variety of on-line systems available from local electronic bulletin boards to America Online to Internet.

"The Internet Complete Reference" by Hahn & Stout (Osborne/McGraw-Hill) and "Internet Start Kit for Macintosh" by Adam Engst (Hayden) come with software and free Internet access included in the prices of the books.

□ □ □

Barry Mishkind can be reached at 602-296-3797, or on FidoNet at 1:300/11.3 or "barry@coyote.datalog.com" on Internet.

## Our panel of experts agrees with your listeners! The Unity 2000i high end sounds better.



Their high end sounds artificial. Female voices sound harsh and some harmonics from the original source seem to disappear.



Thanks to our Linear Response Algorithm™, the Unity 2000i high end sounds more musical and natural, with greater perceived loudness.



The Unity 2000i. The world's best sounding FM processor. Better sound, more listeners, bigger profits. That's what it's all about.



CUTTINGEDGE

2101 SUPERIOR AVENUE, CLEVELAND, OHIO 44114 • TEL: (216) 241-3343 • FAX: (216) 241-4103

# WORKBENCH

## Nothing Replaces Visual Inspection

by John Bisset

**FALLS CHURCH, Va.** I had the pleasure of moderating the "Radio Transmitter Workshop" at the National Association of Broadcasters convention. NAB invited several AM and FM transmitter service engineers to discuss repairs and maintenance for their respective products. Tapes of the session are

available from NAB, and are worth the money, because the speakers were candid.

One of the speakers, Gerry Meier of CCA, described how important it is to make a thorough visual inspection of a transmitter when it fails. His tip was particularly meaningful to Don Larsen, a contract engineer in Idaho.

Don has two different clients that own

recent-model CCA 25 kW transmitters. He was faced with the same problem at both stations.

The plate breaker tripped, but there was no visible damage. He would simply reset the breaker and was back on the air.

(He has been reading the plate breaker reset schemes reported in this column over the last year with great interest.)

After a recent plate breaker trip, Don was cleaning the HV wires leading from the secondary of the plate transformer up to the rectifier stacks. (All breakers were off, of course, and the caps had been checked with the shorting stick.)

He discovered wires running down the back of the transformer and drooping down toward the front of the transmitter on their way to the HV stacks. The wires fell against the sharp edge of the aluminum chassis holding the screen supply components. There was a very clear carbon trace indicating an arc.

Surprisingly, there was no indication of burning on the chassis.

Don rerouted the wires, and left to check his other client's transmitter—same problem, same place.

At this printing, there have been no more breaker trips in the three weeks since he rerouted the wires. There had been one a week, so Don believes he has corrected the problem.

One of my clients has a CCA transmitter, so I checked the wiring on his HVPS and found it correctly routed away from the screen supply chassis edge. It is hard to say whether the problem affects all transmitters of this make, but it is worth a check.

In fact, thorough cleaning of the HVPS wires on a regular basis is always a good idea. I had a similar arcing problem on a

Continental "Power Rock" several years ago. The HV wire to the large capacitor in the PA passed around the edge of an aluminum shield and arced.

Faults like these are very difficult to see. Don suggests using a strong trouble lamp and plenty of alcohol-laden cleaning rags.

I asked Don why he focused on the transmitter and not the incoming power. He replied that at one site he ran his CCA in a combined arrangement with another manufacturer's transmitter and never lost a breaker on the second transmitter.

Furthermore, he had installed an Angstadt phase monitor, which responds to the slightest line faults. There was no indication of electrical problems.

Don had also taken precautions on the incoming AC lines by installing Harris MOVs, which he bought out of the Newark catalog. He used the V131-BA60 across each leg to ground for three-phase "Y" feeds.

For a tapped Delta or "Wild-leg Delta," use the V131-BA60 for the two normal phases, and a V251-BA60 for the high leg. The MOVs are priced at just under \$100 each, which is inexpensive insurance during the lightning season.

Don Larsen can be reached at 208-357-7864.

★ ★ ★

Most engineers at some time experience ITT/Schadow multiple pole or ganged pushbutton switches on a console. Console manufacturers usually put silver-plated contacts on these switches.

Michael McCarthy of McCarthy Radio Engineering searched for a distributor that would supply the full line of Schadow switches, including flashed-contact switches, and found it, Hawk Electronics in Illinois.

Hawk sells ITT/Schadow gold-flashed, all the individual mounting, interlocking bars, springs and miscellaneous parts to broadcast engineers and other end users.

continued on page 21 ►



## A Clear Switch.

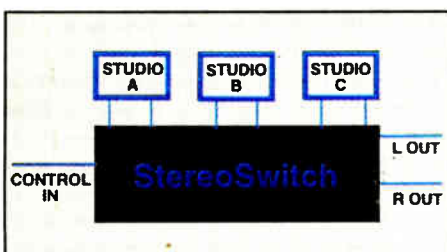

There is no circuitry in the audio path, making StereoSwitch totally transparent to the source.

StereoSwitch is easy to install and can be controlled by any switch, contact closure, DC voltage, or computer DC logic signal.

Best of all-- it's inexpensive. And, it's available now from the broadcast pros at Harris Allied. The choice is clear. The call is free.

8:00 a.m. to 8:00 p.m. EST

1-800-622-0022

Fax 317-966-0623

StereoSwitch is a versatile, three-input stereo audio switcher that offers dozens of uses for your radio station.

Use it as a studio switcher...a line selector...or for automatic source selection under the control of a broadcast automation system.

StereoSwitch utilizes sealed relays with gold-plated contacts for audio switching.

**HARRIS ALLIED**

©1994 Harris Corp.

### FM STUDIES

- **SPACING/INTERFERENCE SEARCHES** to locate a channel
- **DETAILED INTERFERENCE STUDIES** optimizing site location and directional antenna designs (calculates allowed ERP on all 360 bearings)
- **TERRAIN ELEVATION RETRIEVAL** determines HAAT for 8 or more radials
- **DISTANCE TO CONTOURS** plots projected coverage
- **POPULATION COUNTING** to determine potential listening audience
- **COVERAGE MAPS AND OVERLAYS** depicts signal coverage, zip code boundaries, received signal level, terrain shadowing and more

**dataworld**  
A Service of DW, Inc.

(301) 652-8822      (800) 368-5754

## MOVING?

**Don't leave us behind!**

Mail or fax your current label and new address (with effective date) to:

Circulation, RW,  
PO Box 1214  
Falls Church, VA 22041  
or  
FAX 703-998-2966. Address changes will be processed within four weeks of receipt.

Thanks!

# Toys or Tools\$?



Digital workstations need to be more than fun... they must be productive. If you work in the fast-paced frenzy of radio production, you don't have time to play around. To get ahead, you need a system that will help you produce more work with greater creativity, in less time. We have just the tool for you, the ADX digital audio workstation.

The ADX is specifically designed for radio production. It has all the features you need to create the most complex multitrack productions: true 8 channel recording (expandable to 32 channels), non-compressed linear PCM digital audio, removable storage media and expansive timecode facilities. But the most powerful feature of the ADX is its intuitive operation. No other workstation has combined all this power with the ease-of-use that makes even the most complicated production virtually effortless.

ADX is the only workstation to offer the optional Mixstation™ automated mixing system. In fact, the ADX is the only completely integrated radio production tool on the market. What else would you expect from PR&E? Call today for your full color brochure.



Pacific Recorders & Engineering Corporation  
2070 Las Palmas Drive • Carlsbad, CA 92009  
Tel: 619-438-3911 • Fax: 619-438-9277 • GSA Contract: GS-03F-4064B

**DESIGNS THAT MAKE THE DIFFERENCE**

# "Easy ISDN"

## \$368 per mo. or \$6,995\*

ANALOG & DIGITAL AUDIO

### RE 660 MUSICAM Encoder

Stadium  
News Site  
Studio  
Advertising Agency  
PC Data

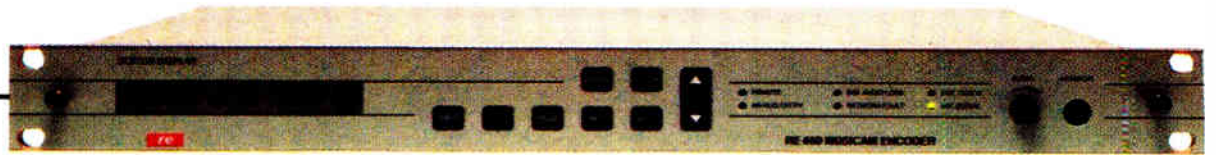

ISDN  
TERMINAL  
ADAPTER



ISDN  
TERMINAL  
ADAPTER

ANALOG & DIGITAL AUDIO

### RE 661 MUSICAM Decoder

Audio Recorder  
Transmitter  
Advertising Agency  
Studio

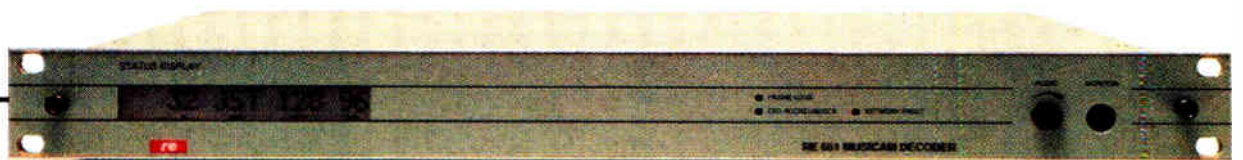

Everything you'll need to link up with the world in one neat package. One great price. One reliable source: Harris Allied. A complete digital audio transport solution for \$368 per month\* or \$6,995\*:

- RE 660/661 ISO/MPEG Layer II Digital Audio Encoder and Decoder
- Two Adtran ISU 128 Terminal Adapters
- NT-1s included in the ISU 128s
- Set of V.35 Connector Cables

In addition you will receive the RE Support Program that includes a step-by-step installation guide; a digital network access guide; a DIGIFON digital dial-up list (the subscription to ISDN Yellow Pages) and 1-800 Helpline & ISDN check-out lines.

Setting up a private network can be expensive, but has been necessary in broadcast applications. The widespread availability of the ISDN digital network offers a new high-quality, low cost means of audio programming. The RE 660/661 MUSICAM Codec gives you an audio pipeline to the ISDN digital networks.

ISDN is becoming part of the broadcast and audio industry's daily lives. ISDN is also becoming as easy to order and as inexpensive as plain old telephone service. Think of it — now you can "phone-in" CD-quality 20 kHz stereo or two channels of mono audio from just about anywhere on a single ISDN line.

With the Easy ISDN package, you simply enter and store phone numbers in the Adtran ISU 128 connected to the RE 660 Encoder or RE 661 Decoder. It's that easy to dial-up on demand your own digital audio transport system and send audio in real-time. There's even an easy way to upgrade your system with future enhancements as they are made to the ISO/MPEG Layer II standards.

The call is free. The package is a must. But, the price is only for a limited time. Call us today and ask for the "Easy ISDN" package.

**8:00 a.m. to 8:00 p.m. Eastern**  
**1-800-622-0022**  
**Fax 317-966-0623**



\*Offer good in North America. No quantity discounts apply. All orders subject to credit approval. Standard terms and conditions apply. Financing based on 24 months at \$368 per month. ©1994 Harris Corp.

# WORKBENCH

# Multitone On-Air Tests

▶ continued from page 18

Gold-contact switches are more expensive than their silver-plated cousins, but the pay-now-or-pay-later philosophy applies in this case, Michael says. The gold-contact switch lasts much longer than the silver and 2/4 pole double throw switches sell for less than \$8 each.

Hawk offers a substantial discount if the total switch order exceeds 100 pieces. Gold-contact switches cost only a dollar or two more than the silver after the discount.

On one occasion, several stations pooled their switch requirements and bought over 500 for both Audiotronics and PR&E consoles. The shared discount allowed each station to rebuild an additional console. Hawk worked closely with each station, supplying only what they needed.

Michael's advice is to forget paying list price plus 99 percent to replace failure-prone silver contact switches. Go for the gold. His contact at Hawk is Glen Labrose, who can be reached at 708-459-4030.

Hawk also distributes a wide variety of spare parts besides switches. For more information, circle Reader Service 161.

★ ★ ★

I recently received a call from an engineer who described a mysterious 10 kHz whine, which he had traced to his Optimod® Stereo Generator. "Old salts" will know the problem here is in the power supply. The whine is caused when the power supply filter caps go bad, and the power supply regulators start to oscillate.

Just replace all power supply electrolytics, and watch the problem disappear. This has got to be the weak link in what is otherwise an extremely well-built box.

While inside the Optimod, take a look at the extensive use of ferrite beads and RFI protection. Amidon Associates, North Hollywood, Calif., sells a wide range of ferrite beads, as well as ferrite rods, toroidal cores and related components. For a copy of their application notes, circle Reader Service 100.

★ ★ ★

Jensen Tools has released the "Jensen Connection," a new catalog full of tools and connectors for PCs, LANs, CATV and security systems. For a free copy, circle Reader Service 110.

John Bisset is a principal with the contract engineering group Multiphase Consulting. He can be reached at 703-323-7180. Submissions to "Workbench" may be sent to his attention, in care of RW, or faxed to 703-764-0751. He can also be reached at 703-323-7180. Published submissions qualify for recertification credit for all SBE certification levels.

▶ continued from page 13

Equipment adjustments are simple. The user can see the response of the entire

change in the rules. It is up to broadcasters to file a petition with the Mass Media Bureau before anything can be done by the FCC.

Multitone alignment tapes for analog cart and reel-to-reel machines are not yet available, but it is easy to prepare alignment tapes and carts using accurately calibrated machines. A standard reference level tone and continuous multitone are all that is needed. The traditional X-Y oscilloscope with a high-resolution display can be used to set the phasing.

Equalization adjustment is easy because it is done while observing the spectrum in real time. There is no need to shuttle the tape back and forth or wait for the right tones to come up on the alignment cart. High-frequency saturation is no problem because the multitone is below reference level.

A multitone signal sounds a bit like a

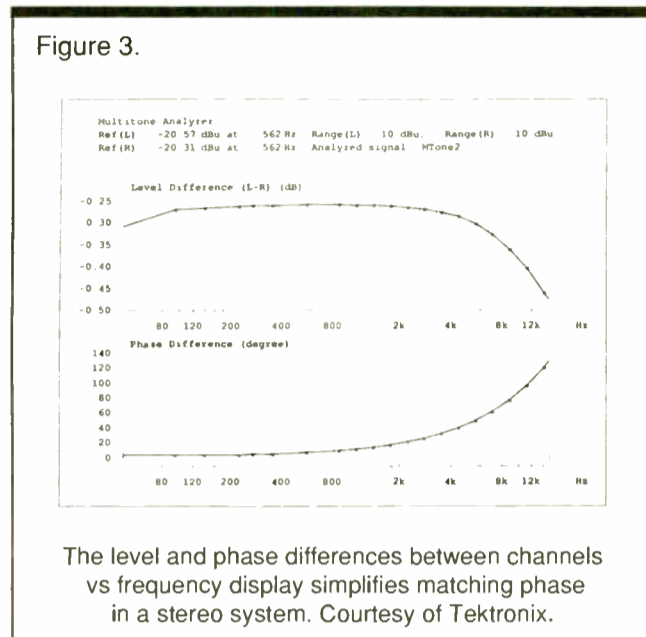

audio spectrum in real time. Typical displays are shown in Figures 2, 3 and 4.

### Procedures

An engineer can test an unattended transmitter using multitone systems combined with computer technology.

The multitone transmitter at the studio sends a one-second burst, which is recovered by the test set, which is typically connected to the demodulator output at the transmitter site. The computer stores the data and it is a simple matter to download it back to the studio via modem.

Figure 5 shows a typical remote multitone operation.

A multitone test provides the same information as a proof of performance, but the FCC does not accept it as such. The commission requires discrete tones and is not currently considering any

maladjusted pipe organ. Some stations may want to replace the traditional beep at the top of the hour with a one-second

Figure 4.

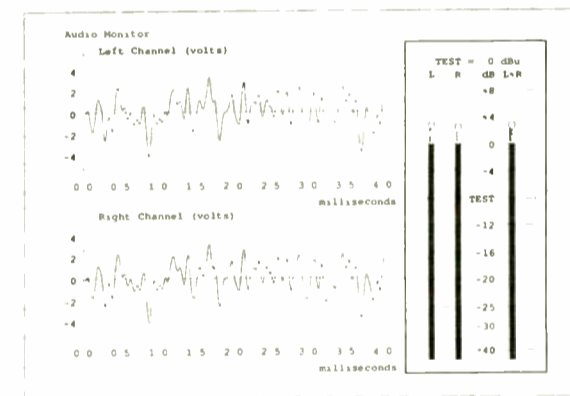

Multitone is very similar to program audio because the crest factor is similar to music or voice waveforms, and because it occupies most of the audio spectrum. Courtesy of Tektronix.

Figure 5.

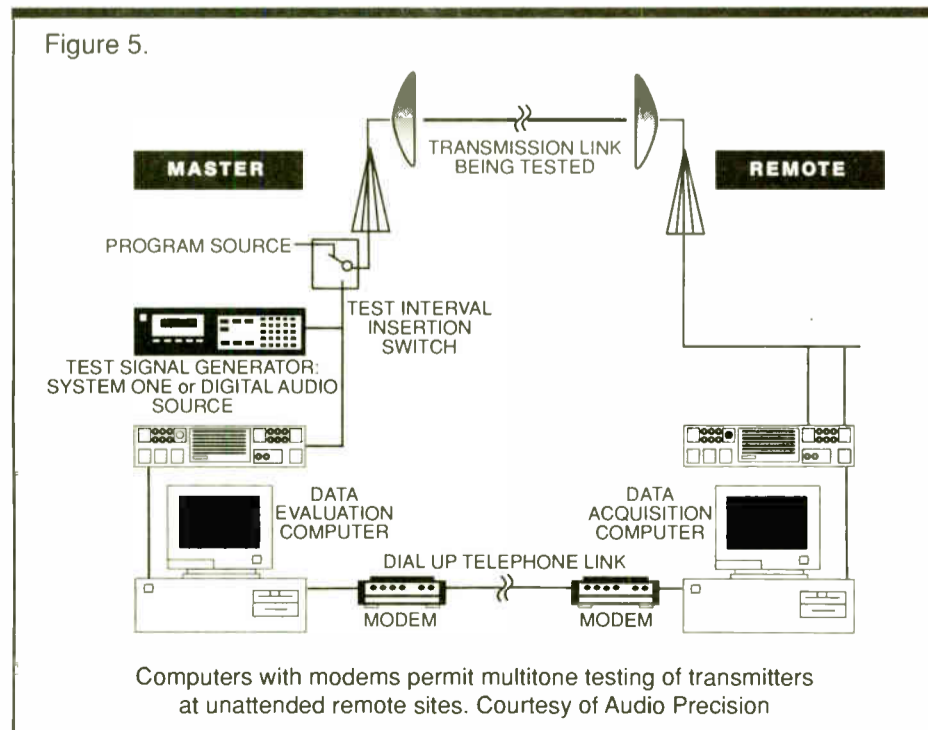

multitone burst and test overall system performance hourly. (That's quite an improvement over trying to schedule an overnight once every six months.)

The next installment in this series will focus on two of the leading multitone testing systems, the Audio Precision System One, and the Tektronix AM700 Audio Measurement Set.

□ □ □

Special thanks go to Bob Metzler of Audio Precision, Tom Newman of Schmid Telecommunication and Bill Thompson of Tektronix for materials provided and other assistance.

Tom Vernon divides his time between consulting and completion of a Ph.D. He is occasionally sighted at WXPN(FM) Philadelphia. Call him at 717-367-5595.



## LMA/DUOPOLY CONTOUR MAPS

The DATAWORLD LMA/DUOPOLY Market Survey Contour maps present a precise electronic verification of overlapping and intersecting contours.

AM 5 mV/m and FM 3.16 mV/m City Grade contours are shown in full color, including transmitter site indicator. The map is supported with a printout showing all of the stations which appear on the map.

Daily updating of DATAWORLD'S AM and FM databases protects against errors and omissions.

### OTHER MAP OPTIONS

- SHADOWING (TERRAIN SHIELDING)
- CONTOUR COVERAGE
- POPULATION DENSITY
- ZIP CODE BOUNDARIES
- RECEIVED SIGNAL LEVEL
- SPECIAL REQUIREMENTS

## 1990 CENSUS

### WHO ARE YOUR LISTENERS?

### 1990 BUREAU OF CENSUS POPULATION COUNTING

- Comprehensive Ethnic and Demographic Data
- Ethnic/Demographic Data Available for Each Zip Code Within Coverage Area
- Age Analysis Reflected in Ethnic Breakout
- Resolution Increased to Block Level
- Percent of County Coverage Shown

### ETHNIC PIE-CHART DISPLAY

- Projects Ethnic Population in Multi-Color Pie Chart Form

dataworld®

800-368-5754 FAX: 301-656-5341



**Where can you get a feel for digital audio production?**

**N**ow's the time to get your hands on SoundLink —the first Random Access Digital Audio Multi-Track system with all the critical functions you need at a price you can live with.

An all-in-one system, SoundLink provides hard disk recording, mixing, non-destructive editing, signal processing and MIDI recording in one comprehensive and affordable package.

If you want a whole new feeling about digital audio production, please call Korg Professional Audio at 800-645-3188 Ext: 280.  
In NY, call 516-333-9100.

**SoundLink™**  
**KORG**  
Professional Audio

# Studio Sessions

A look at the **Flashback**, see page 25.

Equipment and Applications for Radio Production and Recording

## BENCHTEST

# MD Cart Technology Impressive under Test

by Ken C. Pohlmann  
Hammer Laboratories

**MIAMI** Even when the MiniDisc was still only a twinkle in Sony's eye, there was talk of developing professional MD applications. Clearly, the cartridge's small size, along with the system's ability to withstand shock and vibration, targeted it primarily at portable consumer applications.

However its rapid random access, recordability, erasability, durability, and editing features also brought another target into the sights: the aging, NAB cartridge or "cart."

The radio industry has a love-hate relationship with the NAB cart. On one hand, its lame sound quality and sluggish behavior

make it disliked. On the other hand, its universality and years of reliable service make it firmly entrenched. Still, as a variety of new digital replacements have already shown, the cart is more vulnerable than venerable. There is no question that the MiniDisc has a legitimate shot at the cart market.

### Features

Thus the MD cart recorder was born and now includes products from Sony, Otari and Denon's DN-990R that are now being introduced to radio stations worldwide. Although the Denon DN-990R's innards may harken back to its consumer origins, its exterior and operating demeanor are clearly professional. The DN-990R is a table-top

unit, (as is its play-only sibling the DN-980F). Three units can be installed on 19-inch racks (3U) using rack shelves. The face must be within 15 degrees of perpendicular.

As with consumer MD recorders, it employs magneto-optical technology to record data at a 44.1 kHz sampling frequency. Using the ATRAC data compression algorithm, it can accommodate up to 74 minutes on a disc. In addition, up to 255 tracks can be recorded on a disc, along with title information.

The DN-990R's front panel is purely functional. A MD cartridge is loaded into the top slot, and mechanically ejected via a lockable Eject button. Principal operating controls are the lighted Play/Pause, and Standby/Cue buttons. A Select knob lets you choose track numbers, and perform editing and presetting operations; the item is selected when the knob is pushed.

A concentric ring provides either single track or continuous playback. A Record button puts the unit into record mode; two search buttons are used to change the play

start position, and enter editing operations. A Mode/Cue button switches between normal playback/record and editing modes. A Display/Caps/Number button switches the display readout (elapsed time, remaining time, track title), and selects different title inputs. An End/Monitor button monitors the end of the track while in standby mode, and clears cue signals. Finally, a fluorescent display shows audio levels, track number, title, time (in minutes, seconds and 75 frames per second) and other parameters.

Around back, the unit has four XLR connectors for left/right analog input and output; these are balanced lines with pin No. 3 hot, nominally set at +18 dBm. Four recessed screwdriver potentiometers provide input and output level adjustment; the maximum input varies from +22 dBm to -6 dBm; the output varies from +22 dBm to -20 dBm. (Sixteen-bit conversion is employed). In addition, there is a low impedance stereo headphone jack.

Two more XLR connectors provide digital in/out, a feature that is not yet contained in



Denon DN-990R

## PRODUCT EVALUATION

# Denon DN-990R Well Suited For Production Room, On-Air

by Chris Crump

**MAITLAND, Fla.** Just the thought of not having to deal with analog carts is a big plus in my book. And getting a chance to try the new Denon DN-990R MiniDisc cart recorder doubled my excitement.

This box is packed with features and advanced technology that make it attractive to not just the jocks but also engineering and production as well.

Since the life of a MiniDisc (MD) is pretty much indefinite, you don't have to send them off to be repacked every 400 plays. No head cleaning, easy to store, MiniDiscs come in 60- and 74-minute configurations. So you can put 60 or 70 one-minute spots on each disc. You can record up to 255 tracks per disc, which means the capability to store your entire passive element and promo library on one disc. Or all spots on two discs.

### Operational aspects

One look at the DN-990R MD cart recorder and I could tell that it operates nearly identical to the Denon DN-951FA CD Cart players that we run in both of our FM studios. So, for the on-air folks that use the Denon CD Carts, it's good for the learning curve.

Recording is so simple, even a program director could do it. The DN-990R will not record over existing tracks unless you want it to. It automatically increments to the first available track. So if there are seven existing tracks on the disc, the MD is advanced to track eight when "record" is armed.

There are some very useful presets that will allow you, for example, to set the start cue at the first audible point of the recording. This sound detection feature is set at the factory for -60 dB but it is adjustable. Other neat features from a production room perspective include: start time delay; copy prohibit encoding; 13-digit character dis-

play for disc/track titles, time display and system messages; and editing functions that allow you to combine, divide, delete, move and title tracks. You can also set cue signals throughout a track and remove them just as easily.

The unit has both digital and analog inputs/outputs. The digital input is great for CD and DAT transfer because the DN-990R

continued on page 27 ►

**Perfect Bob.**

**Perfect Judy.**

**Push Here.**

128 User Programs  
De-essing  
Parametric EQ  
Compression • Limiting  
Automatic Gain Control (AGC)  
Dynamic Noise Reduction  
Downward Expansion  
Echo • Doubling • Modulator.

**The programmable 601 Digital Voice Processor.**  
Pushbutton perfection for every on-air voice.

**206.282.2555 800.288.8855**

**Symetrix**

## PRODUCT EVALUATION

## Mixes Are 'Easy' With Monitor One

by Bruce Bartlett  
with Jenny Bartlett

**ELKHART, Ind.** Reviewed here is the inaugural loudspeaker from a company known for its low cost electronic sound boxes. And in my opinion, Alesis has built a fine speaker on its first try.

Well known in the home studio/project studio market for the ADAT digital multitrack, signal processors, and other products, Alesis recently introduced the Monitor One. The speakers have been heavily promoted and generally well received by their users. Radio World's panel of judges bestowed a 1994 Cool

Stuff Award on the Monitor Ones at the recent NAB convention.

**Features**

The Monitor One is a mid-size, two-way ported speaker selling for \$399 a pair. The product was designed by Alesis speaker engineers Frank Kelly and Walter Dick. Kelly worked with UREI for 17 years, while Dick designed speakers for 25 years with JBL, Gauss, and others.

In the speaker's design, the aim was to get a basically flat response within the cost constraints. The engineers wanted the speaker to sound up-front and

detailed but not harsh. Controlled dispersion was another goal. The speaker was meant to sound good with a wide

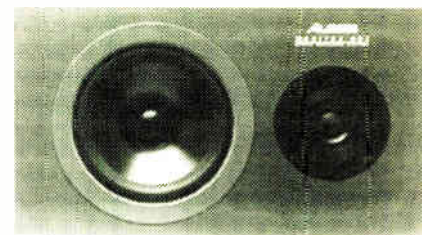
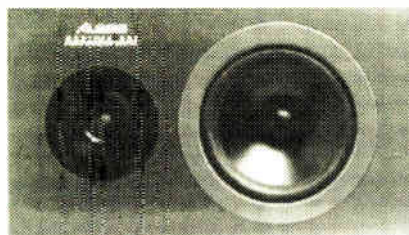

Sales are brisk for the Monitor One, according to Alesis.

range of music, but not cost a lot.

When I removed the Monitor Ones

filled polypropylene cone that is said to reduce breakup. It crosses over at 2500 Hz to a 1-inch, silk soft dome tweeter. This material was chosen to reduce stridency in close-up use, Alesis said. The tweeter is ferrofluid cooled to improve power handling. The claimed power handling is remarkable—twice that of most other nearfields. The Monitor One can handle a whopping 120 watts continuous program and 200 watts peak.

The speaker enclosure is vented in back with a "SuperPort" that is large enough to prevent turbulence; the claimed result is tighter, deeper bass. The system measures (when positioned horizontally) 15-inches (width) by 9.25-inches (height) by 8.5-inches (depth). They weigh 15 pounds each. On the

**In the speaker's design, the aim was to get a basically flat response within the cost constraints. The engineers wanted the speaker to sound up-front but not harsh.**

back is a pair of 5-way binding posts, angled for easy access and ready for large-gauge cables.

Sensitivity is rated at 88 dB SPL/W/m, which is average. Alesis specs the frequency response as 45 Hz to 18 kHz +/- 3 dB. Impedance is 4 ohms.

**Listening tests**

I listened to the Alesis Monitor Ones before making any measurements. The speakers were placed just behind my mixer, 3 feet apart and 3 feet from me. Their fronts were about 2.5 feet from an absorbent wall behind them. These were my impressions of several CDs played through the Monitor Ones:

- **Kamakiriad**, Donald Fagen (pop/R&B): Plenty of deep, tight bass; no need for a subwoofer. Highs are smooth and gentle, easy on the ears, but not muffled. A full, warm sound.
- **Reckless**, Bryan Adams (rock): A little less "edge" or impact than many other speakers; detail is slightly reduced.
- **Unplugged**, Paul McCartney (acoustic): Guitars sound delicate, not twangy or etched. Sibilants are smooth. Elegant

continued on page 32 ▶

# Owning a Real Neumann Just Got a Lot Easier

You've put a lot of money into your studio... expensive consoles, recorders, processing, etc. But your recordings just don't measure up to your expectations. Chances are, the problem is with the most important (and most often overlooked) part of your signal chain... the microphones.

Virtually every major recording produced during the last 50 years has utilized Neumann microphones on vocals and critical tracks. And with good reason. Neumann microphones sound better. The warmth. The texture. The velvety smooth richness that cannot be duplicated. It's called the "Neumann Sound."

The TLM 193 is a large diaphragm cardioid condenser microphone with state-of-the-art specifications. Frequency response of 20Hz to 20kHz, dynamic range of 130dB, self noise of 10dB-A, and maximum SPL of 140dB.

Mics like the U 47, U 67, U 87, and the TLM 170 are legends in the industry. Now, with the TLM 193, you can have Neumann performance in the classic tradition for less than \$1300 us!

Make your next recording a classic. Use Neumann... the choice of those who can hear the difference.

## Introducing the TLM 193 Large-Diaphragm Condenser Microphone



# Neumann|USA

6 Vista Drive, PO Box 987 • Old Lyme, CT 06371  
Tel: 203.434.5220 • FAX: 203.434.3148  
West Coast Tel: 818.845.8815 • FAX: 818.845.7140

### Neumann|Canada

221 LaBrosse Ave., Pointe-Claire, Quebec H9R 1A3  
Tel: 514.426.3013 • FAX: 514.426.2979





SIGNAL-TO-NOISE

# The 'Tapeless, Diskless' Flashback Recorder

by Frank Beacham

**NEW YORK** Scenario. Scotty Quick, an Action Radio news reporter, darts quickly through Gotham City Hall, frantically moving on to his tenth story of the day.

To prepare for his upcoming interview with the mayor, Scotty pops a new SoundClip into his Flashback audio recorder. Since the recorder weighs only three ounces, Scotty doesn't even feel it bounce in his shirt pocket as he struts down the hall toward the mayor's office.

**A sound clip**

After the interview with Mayor Bluster, Scotty realizes he's got the day's lead story. And it will work perfectly with that contradictory sound bite he recorded on another SoundClip earlier in the day at the city council meeting.

Only minutes before airtime, Scotty pulls his Apple Newton from his shoulder bag and inserts a SoundClip. With a touch of his pen, he activates the Newton's audio editing program. Within minutes, sound bites of the mayor and his city council nemesis are combined with a voice over into a complete news segment.

Next, Scotty brings up the communications program in the Newton and instructs it to dial the station's newsroom computer. Within seconds, the segment is transferred through the phone line and is ready for instant air play.

Back at the station, Scotty decides to enter the interviews he's recorded that day into a data base. One never knows when Mayor Bluster will contradict himself again. Not only does Scotty want to keep the actual sound bites but

a written transcript of the interviews would be useful as well. Within seconds the station's new "speech-to-text" software creates a word processing document of the day's interviews that can reside on the computer disk with the actual audio recordings.

If all this sounds a bit futuristic, consider the fact that every part of this scenario is now not only possible but probable within the next couple of years.

**Flash RAM**

Flashback™, the three-ounce recorder mentioned above, will be available in about 100 top consumer electronics outlets beginning this July. It's a totally solid state audio recorder without motors, read/write heads or any other moving parts. The recording media, called a SoundClip™, is flash memory, a non-moving and non-volatile (i.e. needs no battery back-up) chip that is impervious to magnetic fields and can be recorded over hundreds of thousands of times or archived for years without degradation.

The removable SoundClips are compatible with PCMCIA "plug and play" cards and thus can be easily used as portable memory with virtually any kind of computer. This compatibility opens the way for many sound manipulation applications, including simple editing programs for handheld personal digital assistants (PDAs) and a new generation of speech-to-text programs now available from IBM and AT&T.

Because Flashback uses digital memory, all the features now available on analog recorders can be easily duplicated. In addition to the Record, Play, Fast Forward, Reverse and Pause functions, other unique features in Flashback are: random access search, the ability to

insert edit audio between existing takes (like inserting a new word between other words in a word processing document) and the ability to scan recordings at either a high or slow rate of speed without altering the pitch of the voice.

**Inexpensive**

Last but not least, the cost of Flashback with a 30-minute SoundClip is only \$199.00. Additional 30-min. SoundClips list at \$69.95, but are expected to drop to a street price below

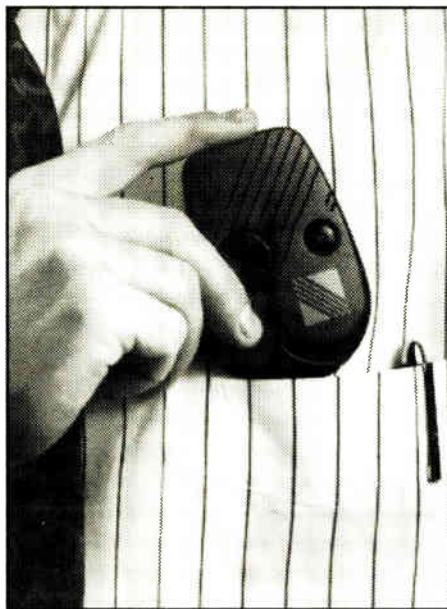

A Flashback in your pocket

\$20 in less than a year.

OK, now that you're drooling, let's talk about the downside. (New technology *always* has a downside, you know.) So far, the sonic quality of the Flashback is not so good. At 300 to 3500 Hz it is slightly better than the audio quality of a telephone. Long recording times can get expensive, since

flash memory costs remain high at the moment. And, of course, all of this editing software is yet to be written for personal digital assistants.

The company behind Flashback is Norris Communications, a San Diego-based holding company that develops, manufactures and markets electronic and audio products for the computer, telephone, defense and medical industries. According to Steven Brightbill, vice president of sales, the company has secured several patents for audio recording on computer memory.

Norris Communications, Brightbill said, is fully aware of the potential of such a recording system for broadcasting and expects to offer professional products in the very near future. He said the 16-to-1 "True Speech" compatible audio compression used in the consumer version of Flashback will improve in sonic quality to the point that stereo music can be recorded onto the flash memory cartridges.

The company also expects to introduce 60 and 120-minute SoundClips within a year of production and Brightbill predicted those storage devices will cost under \$50 and \$100 respectively. "The price of flash memory keeps coming down every quarter," he said. "The length of recording time is only a factor of the cost of flash."

We'll keep you posted on this new flash recording technology and feature a review of Flashback in the coming weeks. Norris Communications can be reached at (800) 905-2225.

□ □ □

Frank Beacham is a writer, director, producer and consultant. His address is 163 Amsterdam Ave. #361, New York, NY 10023.

## Products & Services Showcase

For more information on the products shown below, circle the appropriate Reader Service No.(s) on the enclosed Subscription/Reader Service card or contact the advertiser directly.

**PORTABLE OFF SITE EBS MONITOR \$350<sup>00</sup>**

Tuneable AM/FM Receiver and FCC Certified Decoder Model C.D.



Ideal for use during hours of unattended operation at the studio and transmitter site. With modern remote control equipment the alert message can be put on the air with a telephone.

Decoder in a minibox (price \$250<sup>00</sup>) is available for use with receiver of your choice, or the decoder can be driven by phone line audio.

**Gorman Redlich Mfg. Co.**  
257 W. Union St. Athens, Ohio 45701  
FAX 614-592-3898 • Phone 614-593-3150

READER SERVICE NO. 115

**Introducing (ta-da) The Jr. Audio Director Plus™!**

It's an 8 input to 2 output ON LINE or monitoring device.

\$550

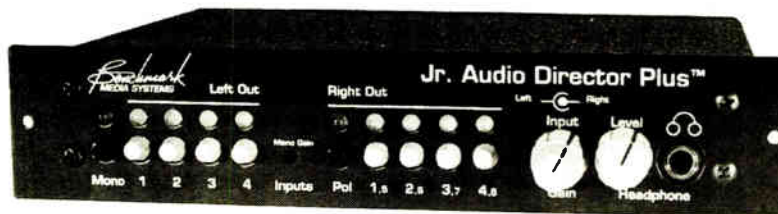

The new Benchmark Jr. Audio Director Plus™ brings more to the party! It brings more control and selection features, and a stereo headphone amplifier, along with the performance and value that are traditionally a Benchmark for the industry.

In a half wide, 1RU high chassis, the Jr. Plus has two input switch banks which allow left and right outputs to select between eight sources. Additional switches provide a Mono Mix, with adjustable gain reduction of 3 to 6 dB, and a Right Channel Polarity reversal. LEDs indicate switch action. Inputs may be passively mixed ahead of the input amp by depressing two or more buttons.

Installation is "instant" with a No-Mod™ Rack Mount adapter and plugable Euro-Style barrier strips.

Available now.



**BENCHMARK MEDIA SYSTEMS, INC.**  
Phone 800-262-4675, or 315-437-6300, FAX 315-437-8119

READER SERVICE NO. 187

PRODUCT EVALUATION

# AKG Mics Offer Varied Features

by Ty Ford

**BALTIMORE** With the technological changes coming as fast as they have been for the last few years, it was a pleasure to step off of the digital fast track for a few moments to give a close listen to a couple of new AKG microphones.

Introduced at the 1993 AES show, the C414B/TLII (\$1499 including mounting bracket and pop filter) and the C3000 (\$699 including mounting bracket) are condenser mics requiring phantom power.

**Features**

The C414B/TLII, positioned by AKG

as the "Vintage TL" uses a recreation of the TL capsule from the 1950s with updated electronics. It has four selectable patterns, -10/-20 dB pads and 75 Hz/150 Hz bass roll offs. Its gold-plated front grill distinguishes it from other 414s.

The C3000 is cost-engineered to be more affordable and appears to be a marketing response to the Audio Technica AT4033. The combination of smaller back diaphragm, switchable cardioid/hypercardioid patterns, a 10 dB pad and a -10 dB/octave roll off at 100 Hz allow AKG to bring the mic to market at a very competitive price. If you don't need the omni or figure eight pattern, and many

broadcast and project studios do not, the C3000 is worth a listen.

To provide a reference I compared both mics to an AKG C414BULS/TL, using the cardioid pattern. Both the new mics exhibited only minor variations from my expectations. Both had that crisp high-end AKG condenser sound. In fact, both mics were brighter than the C414BULS/TL, although neither was as warm and full on the bottom. Beyond that, there were other obvious differences.

The most obvious was that, in cardioid operation, the C3000 yielded about 5 dB higher output than both the C414BULS/TL and the C414B/TLII. That

extra 5 dB will allow you to run your pre-amps at lower gain, which can be helpful if you've got noisy pre-amps.

According to AKG supplied response curves, the frequency response of the C414B/TLII extends both below and above that of the C3000. In the cardioid position, the C414B/TLII is flat down to 50 Hz while the C3000 starts to roll off at 100 Hz and is 4 to 5 dB down at 50 Hz. On the top, both mics have a bump



AKG Vintage TLII

between 6 kHz and 8 kHz. The C414B/TLII's is maybe a decibel higher and its slope after the bump is more gentle, crossing the 0 dB line at about 14 kHz.

**User tests**



In practical experiments, the difference in high-frequency response between the mics became obvious when I added a few decibels at 12.5 kHz to the C3000 to get it to sound a bit more open.

Even though both have somewhat less low frequency response than the C414BULS/TL, they still are susceptible to bass build up when worked close. Because the C3000 rolls off more quickly, it exhibits slightly less proximity effect than the C414B/TLII.

I would suggest using a pop filter with both mics, the TLII comes with one and I found that it also fit the C3000 nicely.

**Summary**

With these thoughts in mind, both the C414B/TLII and C3000 are worth trying

Product Capsule: <b>AKG C414B/TLII</b>	
<b>Microphone</b>	
 <b>Thumbs Up</b>	 <b>Thumbs Down</b>
<ul style="list-style-type: none"> <li>✓ wide frequency response</li> <li>✓ multiple patterns</li> </ul>	<ul style="list-style-type: none"> <li>✓ price</li> </ul>
For more information, circle <b>Reader Service 57</b> ; or call AKG Acoustics at 510-351-3500.	

if you are seeking to upgrade the sound of your live announcers. The extra transients produced by these condenser mics may give you the edge you are looking for to cut through heavy processing, resulting in a more open and natural sound. If you do any kind of skit, radio program production or recording of music instruments, the extra patterns (bi-directional and omni-direction) of the C414B/TLII may come in handy. If not, you can save a few bucks by choosing the C3000.

★ ★ ★

If you're a broadcaster, as good as these mics sound, don't expect to plug them in  
continued on page 28 ►

## ALL DAT TAPES ARE NOT THE SAME BUT DON'T TAKE OUR WORD FOR IT

Ask Studio Sound, one of the world's most highly respected professional audio publications.

They recently subjected eight leading DAT tape brands to an exhaustive series of tests and the results should be of interest to everyone serious about audio.

In the critical area of block errors, the tapes fell into two distinct categories of performance. Three exhibited similarly low error rates with the others presenting error levels

considerably higher. HHB DAT Tape was one of the leading three

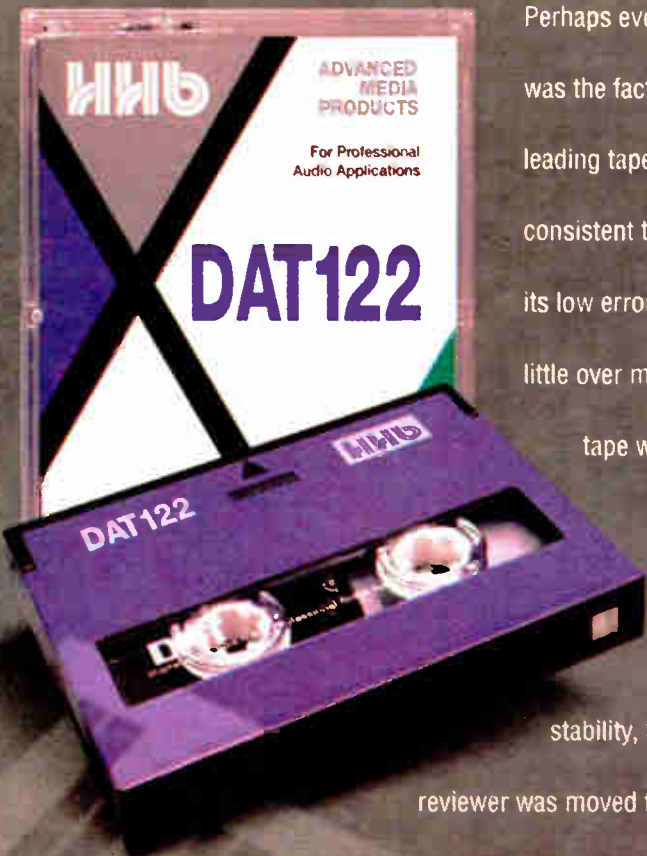

Perhaps even more significant was the fact that one of these leading tapes was clearly more consistent than the others, with its low error rates changing very little over multiple passes. That

tape was HHB.

And when it came to archiving

stability, Studio Sound's

reviewer was moved to write: "If it were

my recordings at risk, it is clear which choice I would make". His choice? You guessed it - HHB.

HHB DAT Tape. Would you trust your recordings to anything less?



Independent Audio - 235 Forest Avenue, Suite 121, Portland, Maine 04101-2000  
Tel 207 773 2424 Fax 207 773 2422

Shader Perplex Canada Ltd. - 1917 Leslie Street, Toronto, Ontario M3B 2M2  
Tel 416 510 1347 Fax 416 510 1294

HHB Communications Ltd. - 73-75 Scrubs Lane, London NW10 6QM, UK  
Tel 081 900 2144 Fax 081 960 1160 Telex 923393

Call Independent Audio today for your free copy of Studio Sound's "DAT On Trial".



# PRODUCT GUIDE

Companies with new product announcements for Studio Sessions Product Guide should send them to Radio World, c/o Studio Sessions Editor, 5827 Columbia Pike, Suite 310, Falls Church, Va. 22041



## Nuverb Digital Effects Card for Macintosh

Lexicon has introduced the Nuverb digital effects card for Macintosh computers that provides digital signal processing and a custom graphics interface capability.

The package also features Lexicon's FX automation feature with EDL, 20-bit processing and easy connection to any AES/EBU digital audio system.

For more information, contact Lexicon at 617-736-0300; or circle **Reader Service 36**.

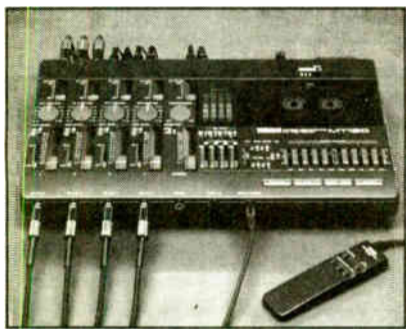

## Yamaha MT120 Multitrack Cassette Recorder

The MT120 is a four track analog cassette recorder/player with two-speed microprocessor-controlled transport, five-band stereo graphic equalizer, MIDI Sync, and dbx noise reduction.

The unit also can be connected to external effects boxes via an AUX send/return connection.

For more information, contact Yamaha of America, 714-552-9011; or circle **Reader Service 41**.

## Audix PH-25 Monitors

Part of Audix's PowerHouse monitor line, the PH-25 is dual-5-inch bass driver, .75 inch-tweeter speaker containing a 30 watt per channel continuous, 60 watt peak power amp built into the rear of the cabinet.

The amp is said to provide low distortion 0.01 THD (mid-band) to deliver the clean, well-defined sound demanded from professional audio equipment. Frequency response is rated 50 hz-18 kHz, plus or minus 3 dB.

The cabinet measures 15-inches (height) x 6-inches (width) x 9 inches (depth). Retail price is \$589.

All Audix monitors can be magnetically shielded. For information, contact Audix at 503-692-4426; or circle **Reader Service 58**.

## MIDI, SMPTE Upgrades for Akai DR4d Hard Disk Recorder

Akai has announced several upgrades for its popular DR4d hard disk recorder including TrackMerging for track "bouncing," and MIDI Machine Control via the optional IB113M interface.

The MIDI option allows control from Mark of the Unicorn's Digital Performer Steinberg's Cubase and Emagic's Logic 2.0.

The upgrade package also features MIDI Time Code, improved SMPTE sync and SCSI-B protocol enhancement.

For more information, contact Akai at 817-336-5114; or circle **Reader Service 121**.

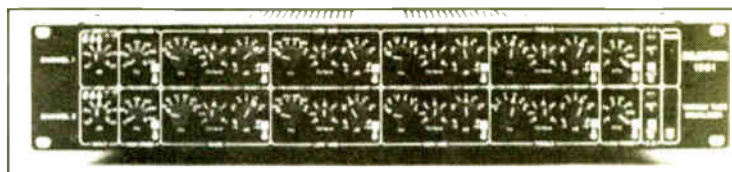

## Drawmer 1961 Vacuum Tube Equalizer

The 1961 vacuum tube equalizer is a two-channel unit designed to provide spectral control with the "sweetness" associated with tubes.

The product features channel input level control with meter, separate tube sections for each main equalizer band. Bandwidth is variable from .3 octave to 3 octaves with plus or minus 18 dB boost or cut. The unit also features low-pass and high-pass sections.

For more information, contact QMI at 508-435-3666; or circle **Reader Service 15**.

## Zobel Industrial Skin Care Cream



The Wergner & Company has introduced a skin care lotion designed for industrial and electronics workers.

The non-greasy, conditioning formula protects against the irritating effects of petrochemicals, most dyes, tints/inks, and contact

with electronic components. For more information, call 203-453-4545.

# Denon MD Cart Recorder

► continued from page 23

will record all of your sub-codes (cues and track numbers) automatically.

Input level adjustment is limited to hardware controls on the back. The range is +22 dB to -6 dB. Not as much gain as I would like, but it

the promos on the air the same way I hear them in the studio. The only difference that I noticed was a good difference. I don't care what some engineers keep saying about compression and artifacts.

Overall, I liked the DN-990R, the jocks liked it, the engineers liked it, production liked it and you will like it, too. Put a couple in the budget for 1995.

□ □ □

Chris Crump is creative services director for Paxson, Communications, WRR-FM, WGFM-FM, WWZN-AM and WWNZ-FM, in Maitland, Fla. and a contributing writer to Studio Sessions.

### Product Capsule: Denon DN-990R MD Cart Recorder



- |   |   |
|---|---|
| <p><b>Thumbs Up</b></p> <ul style="list-style-type: none"> <li>✓ easy-to-use cart replacement</li> <li>✓ digital I/Os</li> <li>✓ rewritable disc</li> </ul> | <p><b>Thumbs Down</b></p> <ul style="list-style-type: none"> <li>✓ needs more display characters</li> <li>✓ some disc jamming (prototype bug—see text)</li> </ul> |
|---|---|

For more information, circle **Reader Service 197**; or call Denon at 201-575-7810.

is acceptable. For production room purposes, it would be nice to have the ability to adjust the input level from the front panel.

### Playback

Playback is simple. Just dial up the track number (or you can search by name) and hit the button. The DN-990R has a remote jack for hook up to your console plus ports for hook up to automation (the same is true of the DN-980F player).

It would be nice if the display screen had more than just 13 characters. The MD will support up to 255 characters but the overall total is limited to 1700 for disc and track titles.

Unless you have an outside sequencing device or some kind of automation device, a bigger cue buffer would be nice. The DN-990R only allows for one track to wait in cue while another is being played. However, the machine has to be in "continuous" mode to play the subsequent track automatically.

One complaint from our folks that used the DN-990R was that the disc loading mechanism did not always work, but we have been told that our test unit was a pre-production unit that still had few bugs. Nonetheless, this one experienced a few stuck discs and some disc protectors (the metal sliding cover that covers the actual disc) would stay open and sometimes jam when ejected.

### Summary

If the ad folks can figure out a good system for adds & pulls, the benefits of the DN-990R are numerous. It would certainly help prevent lost spots and keep the sales people from going into the studio and removing carts without notifying production.

With the DN-990R, it's really nice to hear

## STUDIO SERVICES

### BUY-OUT MUSIC — \$99

Sixty 60-second music beds for . . . \$99  
198 :30 & :60 music beds for . . . \$198  
2200 Hanna-Barbera (C)

Sound Effects for . . . \$495  
110 Lasers & Sweepers for . . . \$99

For FREE DETAILS on production music, sound effects, call

Ghostwriters (612) 522-6256

READER SERVICE 149

### CUSTOMIZED AIRCHECKS ARE HERE!



Broadcast Historian Ed Broder offers customized airchecks of Top 40 legends • Over 2,700 airchecks available • Use our catalogue to build your own collection • Perfect for Oldies Programmers, Collectors, Jocks. We have them all!

Send \$10 for our catalogue. \$5 for cassette.

**MAN FROM MARS PRODUCTIONS**

159 Orange Street  
Manchester, New Hampshire 03104

READER SERVICE 173

### 427 SOUND EFFECTS \$89.00

For a 5-CD set with a 30-day money-back guarantee.

Take an extra \$10 off if you mention this ad!

Send \$79 to Ghostwriters  
2412 Unity Ave. N., Dept. RW  
Minneapolis, MN 55422

For credit card orders call  
(612) 522-6256

READER SERVICE 149

Studio Services are a great, economical way to get your company's message to Radio Station and Recording Studio owners/managers and engineers. Call Simone now and your ad could be in the next issue of Radio World.

### ATTENTION PROVIDERS!

Promote your services to **Radio World's** 22,000+ readers. Reach Radio Station and Recording Studio owners/managers and engineers with your message. For information on affordable advertising call **Simone** at **1-800-336-3045**.

# Denon MD Cart Passes Benchtest

► continued from page 23

Sony's MD cart recorder. These adhere to the AES/EBU and IEC-958 standards. The input does not observe SCMS copy inhibit restrictions, and the output has switchable copy inhibit restriction.

A 9-pin connector provides a RS232C serial port operating at 9600 or 19,200 bits per second (bps); this could be connected to a computer to operate playback, record, editing, and track labelling operations.

Using the front panel controls and rear panel connectors, the DN-990R provides all of the perks you'd expect on a professional machine. For example, you get instant start (100 milliseconds or less), auto cue to the beginning of the music (adjustable from -36

ing during recording. Up to five cue signals can be written per track, as well as an end cue signal.

Moreover, the DN-990R brings all of the editing perks found on consumer MD machines. You'll find the following: non-destructive end-trim, track erasing, track division, track combining, and track re-numbering. You'll also find all the MD titling features.

A peek inside the unit reveals very sturdy construction, with a large power supply occupying a large volume inside the case. The MD transport itself is surprisingly small and somewhat delicate-looking, but it is clearly not the same one used in consumer machines. It is cased in metal, and is shock-mounted on springs.

## Operation

Operation of the DN-990R is straightforward, and can be immediately learned by anyone who is familiar with a cart machine. Of course, everyone who touches the machine will appreciate the joy of random access audio. The ability to instantly access recorded tracks, add and delete material, combine, divide and label tracks is awesome.

As I put the unit through its paces, it delivered all this and more. However, this particular review unit, a preproduction model that did not have all of the bugs out of it, according to Denon, sometimes did not access tracks. On some blank discs, it simply refused to locate to some tracks, even though it would play through them and display correct track numbers and times. (Denon said that owners of actual production models already shipping are not reporting this problem.)

In addition, the unit was somewhat slow in accessing tracks in general, perhaps taking

two seconds. (As a result of being able to cue music, Denon said that 0.5 seconds of that time is used to access the track while the rest is used for locating the music.)

## Measurements

The DN-990R's electronics did not have any problems, and performed well on the test bench in both playback-only and record/playback duties. Using a Sony TGYS-1 MD test disc, I observed that playback frequency response was flat to within 0.31 dB; there was a 0.25 dB bump at 18 kHz, and a 0.06 dB dip at 20 Hz. The right channel was offset by 0.2 dB relative to the left. Playback channel separation measured 100.3 dB at 1 kHz, and 94.1 dB at 20 kHz. A-weighted S/N measured 102.4 dB. THD+N at 1 kHz measured 0.0078 percent at 0 dB and 0.032 percent at -20 dB.

Playback dynamic range measured 90.4 dB. Playback interchannel phase error at 20 kHz measured a mere 0.1 degrees, and playback linearity error was -0.8 dB at -90 dB. Line output for an indicated 0 dB was 6.7 volts.

Using a blank Sony MD-60 disc, I also measured record/playback characteristics, using its analog inputs and outputs. Frequency response was flat to within 0.16 dB, with a 0.15 dB bump at 18 kHz. Channel separation measured 99.1 dB at 1 kHz, and 92.2 dB at 20 kHz. A-weighted S/N measured 91.4 dB. THD+N at 1 kHz measured 0.0080 percent at 0 dB and 0.041 percent at -20 dB. Dynamic range was 87.1 dB. Interchannel phase error at 20 kHz measured 0.7 degrees, and linearity error was a reasonable 1.8 dB at -90 dB. Line input for an indicated 0 dB was 6.8 volts.

These are all very good numbers.

The ATRAC data compression algorithm employs psychoacoustic principles to eliminate audio signals that lie under a human's threshold of hearing sensitivity, as well as normally audible signals that are instantaneously masked by louder signals.

To evaluate the DN-990R's implementation of ATRAC, I made a number of recordings of musical material ranging from U2 to Bartok, as well as a collection of jingles, PSAs and voice-overs, using both analog and digital inputs. In addition, I tried a number of pre-recorded MDs.

## Listening impression

After careful listening, I decided the DN-990R's sonic performance was completely within the norm of my experience with other MD recorders. Careful, critical listening reveals slight artifacts in the sound that might be described as altered imaging, and changes in high frequency timbre. To put the artifacts in perspective, with carefully controlled audiophile listening conditions, about half the people I test can hear the difference between a CD and an MD recording of it, and the other half cannot. Hence, those who condemn MD as having vastly inferior sound quality are vastly overstating the extent of the coloration it imparts.

Moreover, as my auditions of the DN-990R showed, the artifacts are most noticeable on full frequency and dynamic range music, and, to my ears, not noticeable on voice and simpler music that ends up on carts. Clearly, compared to the sonic quality of analog cart machines, the MD's sound is a major improvement.

□ □ □

Ken Pohlmann is Director of Music Engineering at the University of Miami in Coral Gables, Florida.

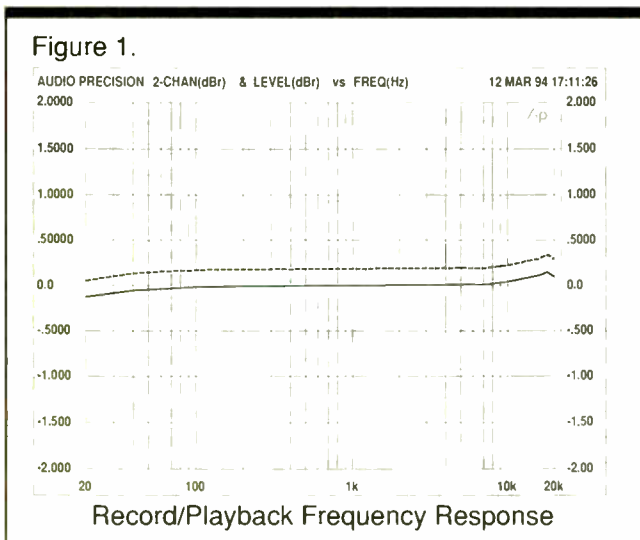

to -72 dB), back cue to return to last playback starting point, end monitor to search for and monitor a track ending (adjustable from 35 to five seconds), track select either singly or in units of 10, stereo/monaural selection, and end of message function (adjustable from 35 to five seconds), fader start, variable pitch (two percent), end mark, and 20 millisecond fade-in.

From a recording standpoint, you get instant record (100 milliseconds or less), auto track increment (adjustable from -36 dB to -72 dB), and manual track increment-

## CD LOUDSPEAKERS

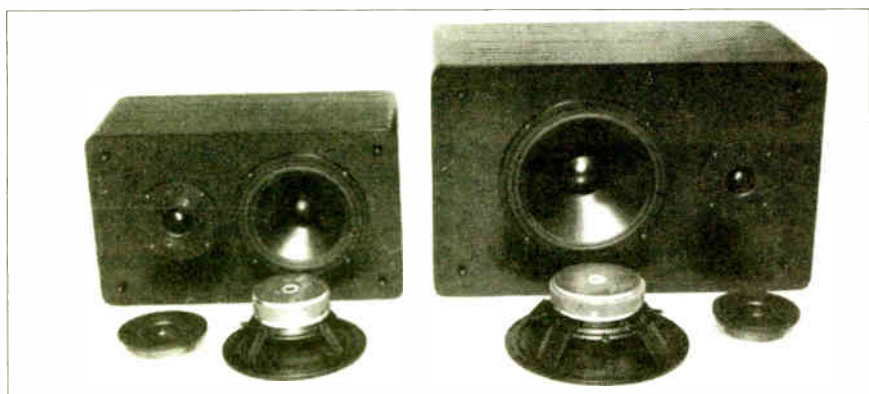

CD 6.2 \$299 PR.

CD 8.2 \$399 PR.

CD STUDIO MONITORS have been designed for accurate sound reproduction, high power handling and long term service. These compact speakers feature European made drivers with polypropylene cone/butyl rubber surround cast frame woofers, ferrofluid cooled dome tweeters, and high grade crossover components. The cabinets are high density particle board with oak, walnut or black finish.

CD STUDIO MONITORS—A sound investment!

**SPEAKERKITS**  
CUSTOM SPEAKERS AND COMPONENTS

516-354-7006  
247-40 Jericho Turnpike  
Floral Park, NY 11001

Circle (128) On Reader Service Card

## Varied Pricing, Features Highlight New AKG Mics

► continued from page 26

and use them without EQ. What and where you EQ each mic will depend on



AKG C3000

sound of the mic.

If you seem to be on an endless road in search of the right mic, consider changing pre-amps, cables and monitors. All of these elements plus the console circuitry and the power amps determine the sound.

And finally, I get a lot of calls from studio people trying to increase the impact of their voice tracks. At the risk of sounding redundant, if you are using

Product Capsule: **AKG C3000**  
Microphone



**Thumbs Up**

✓ price  
✓ high output



**Thumbs Down**

✓ fewer patterns

For more information, circle **Reader Service 176**; or call AKG Acoustics at 510-351-3500.

compression on mics, be careful not to use too much. There are very few compressors out there that sound good with more than 4-5 dB of gain reduction at more than a 4:1 ratio. In addition, adjusting for faster attack times, while providing more control, reduces the natural transients from the voice. These transients are part of what makes a voice cut through on a track.

Ty Ford's latest book, "Advanced Audio Production Techniques," is available by calling 800-366-2665.

your ear, the voice and your existing system. Know that, in some cases, changing mic cables or pre-amps will change the

# THE CART MACHINE GOES DIGITAL! INTRODUCING THE DENON MD CART.

As the company that first employed digital technology to record music, it's not surprising that Denon has become the broadcast standard for on-air CD playback with its CD Cart™ Players. Now, Denon is about to repeat its ground-breaking tradition with the introduction of Denon MD Cart™ Recorders and Players.

Based upon digitally recorded, removeable MD technology, Denon has created the DN-990R MD Cart Recorder and DN-980F MD Cart Player... and in the process has effectively replaced the 25 year-old NAB Cart.

Erase and re-record for commercial/spot production and playback using widely available blank MDs. Record and re-record with CD-like sound quality, durability and reliability.

Audition Denon MD Cart machines today. And remember, whenever digital broadcast equipment is made better, it will be made by Denon.



**DENON**  
The First Name in Digital Audio

# TM CENTURY<sup>®</sup> Inc.

PRESENTS OUR NEWEST  
FULLY INTEGRATED SYSTEM  
FOR FULL AUTOMATION OR LIVE-ASSIST

## ULTIMATE DIGITAL STUDIO II

The screenshot displays the UDS II software interface for TM CENTURY, DALLAS TEXAS. The interface is divided into several sections:

- ON AIR:** Shows a countdown clock at 0:06.7 for the song "Hey Nineteen" by Steely Dan. The Source ID is 01. A large digital display shows "11". A status box on the right indicates the time is 5:00:06 PM on Tuesday.
- > NEXT TO AIR:** Shows the next song, "Invisible Touch" by Genesis, with Source ID 02. It lists the CD as SONY CDK-3600, CD number 936-06, and the date as 3/15/94. The intro length is 16 seconds, and the total time is 3:19.0. The ending is marked as F. The scheduled time is 5:04 PM.
- > NEXT TO FOLLOW:** Shows the following song, "I Stand For You [Edit]" by Michael McDonald, with Source ID 01. It lists the CD as SONY CDK-3600, CD number 949-06, and the date as 3/15/94. The intro length is 20 seconds, and the total time is 3:47.0. The ending is marked as F. The scheduled time is 5:07 PM.

At the bottom of the interface, there is a status bar with the following information: Drive: [indicator], Time Update: OFF, Time Commands: OFF, Logging: [indicator], Printer: OFF, Loading: 00.

- ⊕ NEW COUNTDOWN CLOCK SHOWS EXACT TIME BEFORE VOCAL STARTS AND WARNS THAT END OF EVENT IS NEAR.
- ⊕ FULL WALK AWAY OR LIVE CONTROL WITH JUST ONE KEYSTROKE.
- ⊕ TOTAL EVENT TIME, INTRO LENGTH, ELAPSED TIME, AND ALL IMPORTANT INFORMATION IS ALWAYS CLEARLY SHOWN.

*For more information call your personal sales representative:*



- NEW AUDIO CONTROLLER USES DIGITAL TECHNOLOGY FOR SOFTWARE CONTROL OF AUDIO LEVELS AND CROSS FADES
- NEW BARGRAPH DISPLAY SHOWS AT A GLANCE HOW MUCH TIME IS LEFT IN YOUR SONG, COMMERCIAL, JINGLE, ETC.

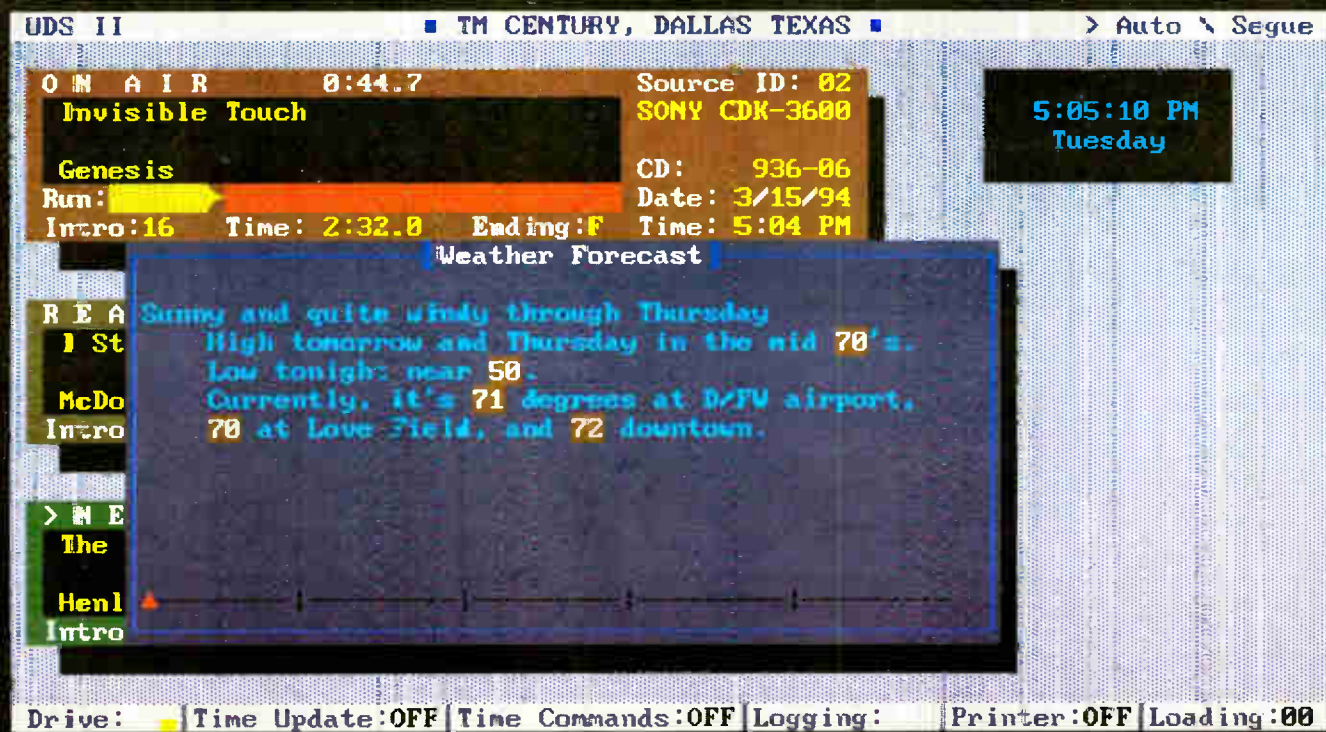

- POP-UP WEATHER, CALENDAR, PSA, AND LINER WINDOWS
- ENHANCED REAL-TIME FUNCTIONS, INCLUDING REAL-TIME NETWORK JOINS
- ENHANCED SUPPORT FOR LOCAL-AREA NETWORKS
- INCLUDES ALL THE FEATURES THAT MADE THE ORIGINAL UDS FAMOUS INCLUDING SUPPORT FOR ALL INDUSTRY-STANDARD MUSIC SCHEDULING AND TRAFFIC SYSTEMS

(214) 406-6800 — (800) TM Century — FAX (214) 406-6890

# 'Easy' Mixes With Alesis Monitor One

► continued from page 24  
sound.



- **Kiko**, Los Lobos (rock): Kick drum is deep and powerful; guitars have a slightly softened edge, and vocals are full and round.
- **Stravinsky's Firebird Suite**, Atlanta Symphony Orchestra (classical): You can hear the very deep bass drum roll at the beginning. It's missing on most smaller speakers. Strings are lush and very smooth. However, they lack air (extreme highs), and the triangle hits are a little softened. Very strong impact on the bass-drum whacks.
- **Time on My Hands**, John Scofield (jazz quartet): Tonally well balanced

from lows to highs. Extreme highs are missing. On other speakers, the cymbals sound crisp and thin; on the Monitor Ones, cymbals sound like they're made of heavier metal.

- **The Road to You**, Pat Metheny Group (world music): Tremendous dynamic impact, yet never harsh or edgy.

- **Blame It On My Youth**, Holly Cole Trio (jazz): Vocal is slightly chesty or midbassy. (This might be due to the wall behind the speakers). The acoustic bass goes extremely low; you can easily hear octave jumps in the bass line. This shows that the speaker has low second harmonic distortion.

In comparison to other recent speak-ers I have re-viewed, the Mon-itor One does

Product Capsule: <b>Alesis Monitor One</b>		
 <b>Thumbs Up</b>	 <b>Thumbs Down</b>	
<ul style="list-style-type: none"> <li>✓ smooth, neutral sound</li> <li>✓ deep, tight bass</li> <li>✓ attractive cabinet</li> </ul>		<ul style="list-style-type: none"> <li>✓ non-extended highs (see text)</li> </ul>
For more information, circle <b>Reader Service 94</b> ; or call Alesis at 310-558-4530.		

very well—especially in the bass. When compared to the Digital Designs DD161b, (reviewed in the Nov. 23 RW), the

Monitor One has somewhat deeper bass, less detail, and gentler highs. However, the DD161b has a retail price of nearly \$750.

## Mixing test

While mixing audio tracks in my home studio, I never felt like I was "fighting" the monitors or compensating for their deficiencies. I simply tried to make the mixes sound exactly like I wanted them to sound.

Mixes made on the Alesis Monitor One translated very well to other speakers, from high-end audiophile systems to cheap boom boxes. The mixes had a solid, chunky quality, with no exaggerated bass, and no funny EQ sounds. This coherency in the sound seemed to hold up no matter what speakers I played the mixes on.

The Monitor Ones have a nice, effortless quality that's easy to live with in long mixing sessions. In this regard, they are like the ubiquitous Electro-Voice Sentry 100s. The easy sound also makes them ideal for all-day monitoring of your station's air signal.

## Measurements

I measured the Alesis Monitor One at one meter with a mic midway between the woofer and tweeter. The frequency response is basically flat, but with a broad 4 dB dip around 3.5 kHz, a rolloff above 12 kHz, and a gradual rolloff below 500 Hz (solid line). This is the anechoic response in "full space." If you place the speakers next to a console, in half space, the bass response would rise about 6 dB. Then

# Now Hear This.

With more digital STL transmission systems on-air than all other competitors combined, we'd like to let our customers do the talking for us...

"The increase in system gain using the DSP 6000 allowed us to eliminate one of the hops in our STL system."

Robert Reymont, KVMY, Phoenix, AZ

"It's truly amazing to drive 120 miles from the studio, hear an FM broadcasting with a totally quiet signal, and know it originated five hops back."

Jim Travis, Family Life Network, Bath NY

"The DSP 6000 allowed us to run both our FMs from one studio over one STL. We got cost savings and digital fidelity."

Chris Reid Murray, KMGE & KGNU, Eugene, OR

"Best sound for the buck in broadcasting today!"

Robert Lear, KTWW, Hollywood, CA

## Moseley

111 Castilian Drive  
Santa Barbara, CA 93117-3093 • USA  
Telephone (805) 968-9621  
Fax (805) 685-9638



**Studio mixes made on the Alesis Monitor One translated very well to other speakers, from high-end audiophile systems to cheap boom boxes.**

the response would be flat down to about 100 Hz (dashed line), and usable down to 45 Hz. The rolloff above 12 kHz is partly due to the wide production tolerances in a low-cost system's drivers.

## Summary

Since the Monitor One has no exaggerated areas in its frequency response, it may sound a bit unexciting when you first hear it. But for mixes and monitoring, that characteristic is desired. The longer you live with it, the better you like it. You may have to work a little harder to get a bright, punchy mix with the Monitor One. But when you do, you know that the punch will translate well to other speakers. I rate the Alesis Monitor One a best buy.

□ □ □

Bruce Bartlett is the author of "Practical Recording Techniques," published by Howard Sams. Jenny Bartlett is a technical writer. Bruce can be reached at 219-294-8388.



DIGITAL DOMAIN

# Transporting Ads by TMX Network

by Mel Lambert

**LOS ANGELES** The great advantage of radio is that it can offer its advertisers a great deal of flexibility in tailoring sales messages on a regional or national basis. Ad production costs are modest, and new or updated versions of a campaign spot can be produced in just a couple of hours. But having the spot available in a New York- or Chicago-based ad agency is one thing;

that offer affordable transponder bandwidth. But how do you make sure that the spot was recorded at each of the down sites and that it will be of sufficient quality to make the process worthwhile?

And there are one or two new systems now coming to market that utilize ISDN or Switched-56 line to carry material from ad agencies to remote stations. Aside from the additional costs involved—new equipment must be installed at each location, and the cost of dial-up digital services is still far from modest; a 56 or 64 Kbaud bandwidth means that a 60-second stereo commercial might take as much as 20 minutes to transfer. (Data-compression may be one way of reducing the transfer time, notwithstanding concerns about signal degradation and tandem-coding artifacts.)

### The TMX Network

One company that thinks it has come up with a better and more user-friendly type of delivery mouse trap is Media Fax who, in conjunction with Trans-Media, earlier this year unveiled the new TMX Network. TransMedia is an advertising production, recording and

duplication facility based in San Francisco. Media Fax began operation as a service of TransMedia in 1989, and provides radio and TV traffic instructions via fax for most of the nation's major ad agencies.

Described as the nation's first direct broadcast satellite network to deliver commercials via Wegener Communications' DR96 SCPC (single-channel per carrier) receivers, the new TMX system is fully compatible with current Wegener C-band dish and down link receivers. The entire system can be hooked up in a couple of minutes, the firm claims, via a simple splitter.

A serial port on each DR96 receiver connects to a Panasonic SV-3900 pro-DAT, which features a nine-pin controller interface. At the uplink site, a series of control pulses sent via the satellite link will put each of the DAT machines at the targeted stations into record mode. Once the real-time transfer of the commercial spots has been completed, a second series of control pulses places each DAT machine into stop mode.

The master DAT tapes can then be removed from the download machine and used to transfer the material to cart for example, or a hard-disk playback system. For stations that lack a DAT machine, the Panasonic SV-3900, for example, might be used to directly replay the material to its final on-air delivery format. The hardware is supplied by TMX at no cost to the station; install and satellite delivery costs are

covered by the ad agencies supplying the material, the company states.

### Using DAT

The ability to simply piggyback on a station's existing C-band channel means that each down site has a unique, password-protected satellite address that does not interrupt its normal feeds. Accessible via Wegener's Addressable Network Control Systems (ANCS), each receiver and DAT machine can be individually or group addressed from TMX's uplink site in San Francisco. Proprietary software is used to control the individually addressable receivers and DAT systems.

According to Media Fax, the TMX Network is intended to make life easier for advertisers, their agencies and therefore radio stations. "The network gives advertisers the ability to deliver spots immediately to any one or all of the stations on their buy," said Media Fax managing partner Doug McVickar.

Simultaneously, TMX also sends via fax the relevant traffic instructions and notification that a particular commercial is about to be delivered.

The new TMX system has been undergoing initial evaluation trials in the San Francisco area for the past several months. Eventually the firm hopes to equip as many as 3,000 stations with down links and serial-controllable DAT machines.

□ □ □

Mel Lambert is a principal of Media&Marketing, a Los Angeles-based consulting service for the professional audio industry. He can be reached at 818-753-9510.

Figure 1.

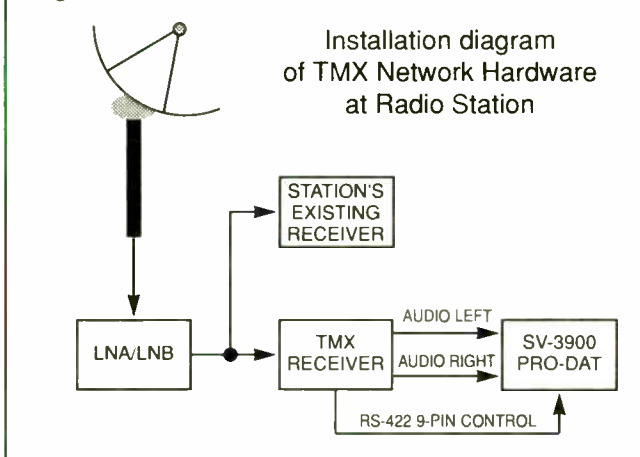

delivering it to a couple of hundred stations in time for a morning media blitz is another.

Sure, we can use a satellite-delivery service to feed targeted stations with the material—and there are plenty of companies

user-friendly type of delivery mouse trap is Media Fax who, in conjunction with Trans-Media, earlier this year unveiled the new TMX Network. TransMedia is an advertising production, recording and

# 50 DIGITAL STEREO TRACKS UNDER \$4,000!

## ~And We'll Prove It!

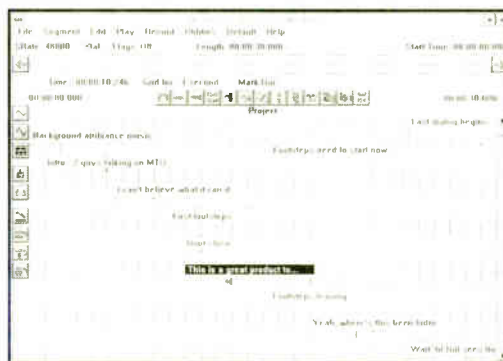

"Excellent sonic quality... incredible freedom!"  
EQ Magazine, October 1993

Plays 50 simultaneous stereo tracks without bouncing!



Complete Work Stations Available!

- Add to your 386/486 computer
- Up to 2,900 segments available per project
- Non-destructive, precision digital edits in under a second
- -110 db noise floor & phase-linear filters
- Non-brittle, crystal clear sound quality
- Backs up to audio DAT
- Easy to install, easier to use!

Call For Your Free Catalog Today!

**919/870-0344**

**FAX/870-7163**

MICRO SOUND  
Digital Audio Workstations



Micro Technology Unlimited • P.O. Box 21061 • Raleigh, NC USA 27619-1061

# Products & Services Showcase

For more information on the products shown below, circle the appropriate Reader Service No. (s) on the enclosed Subscription/Reader Service card or contact the advertiser directly.



The Marlner

## A Console for your Future

- DCA (Digitally controlled analog) faders
- Better than "CD" quality sound
- Modular frames hold 6, 12 or 22 mixers
- Five types of input mixers available
- Optional RS-232 serial interface
- LCD displays dynamically label each mixer
- Programmable machine control system
- 2 Mix-Minus outputs, Talkback & more
- Prices start at \$3900



Call: 800-231-5870 or 713-782-4492 for your nearest Logitek dealer

READER SERVICE NO. 35

## AUTO-ANSWER TELEPHONE COUPLER

Ideal for unattended situations such as listen lines, IFB feeds, dial-up networks, remote transmitter sites & satellite links.

- Clean connection to phone line
- Easy to install
- Send or receive program
- F.C.C. registered



See us at NAB Radio Show Booth 247



Comrex Corp., 65 Nonset Path, Acton MA 01720  
Tel: 1-800-237-1776 Fax: 508 635-0401

READER SERVICE NO. 1

## MULTIPLE AMPLIFIER ARRAYS

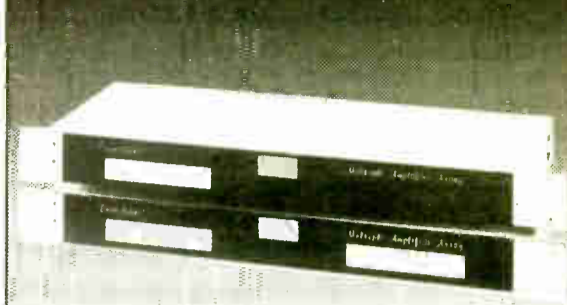

*Have them Your Way!*

### MLA400, MMA400

Four Channel Line and Microphone Amplifiers

### MLA800, MMA800

Eight Channel Line and Microphone Amplifiers

CALL OR WRITE FOR A FREE DETAILED BROCHURE.



AUDIO TECHNOLOGIES INCORPORATED  
328 W. Maple Ave., Horsham, PA 19044, USA  
(215) 443-0330 FAX: (215) 443-0394  
(800) 959-0307

READER SERVICE NO. 24

Byte it with



A Digital Recorder specifically designed to record phone calls and play them back quickly and easily.

Fast nondestructive editing.

Easy access and fast stacking of bits.

The most powerful way to record and air phone-bits.

## The Blue Group

1001 Ridge Avenue  
Clearwater, FL 34615  
TEL 813. 442 1665

READER SERVICE NO. 208

## EVEN THE BEST CAN BE MADE BETTER

Introducing the new

### MINI-MIX 12A

THE COMPACT MIXER WITH A COMPACT PRICE FROM THE QUALITY LEADER



\$3499

12 Channels  
25 Stereo Inputs

Service & Affordable Quality for Over 23 Years



1500 Capital Avenue (214) 424-8585  
Plano Texas 75074-8118 1-800-327-6901  
FAX (214) 423-6334

READER SERVICE NO. 139

## The Circuit Werkes AC-2 Autocoupler



More Features. Better Price.

- Auto-connect and disconnect.
- FCC Pt.68 registered.
- Two-Year limited warranty.
- LED Indicators for audio clipping, incoming rings and line status.
- Answers on user selectable number of rings.
- Momentary or latching dry contacts at pickup.
- Momentary open collector output at pickup.
- Defeatable pickup inhibit function for cart decks, etc.
- Can be combined with Circuit Werkes DTMF decoder board to form a dial-up DTMF remote control.
- Optional ComboLok provides for secured access.
- Suggested list only \$199.

## Circuit Werkes

6212 SW 8th Place  
Gainesville, Florida 32607  
(904) 331-5999  
fax (904) 331-6999

READER SERVICE NO. 70

## TOWER AND OBSTRUCTION LIGHTING PRODUCTS

FLASHER FS155-30T



ALARM RELAY SCR430T



SHORTED FLASHER ALARM SFA430T



PHOTO CONTROL PCR11



SSAC offers a complete line of solid state products to control and monitor the lights on communication towers and other tall structures. SSAC solid state products have proven performance and reliability with years of infield use. Flash single or multiple beacons. Sense lamp failure in the beacon, side lamps, or other obstruction lighting with an alarm output. The PCR11 Photo Control with its all plastic housing is ideal for turning on complete tower lighting at dusk (factory calibrated).

PHONE OR WRITE FOR FREE TOWER CONTROLS MANUAL  
TELEPHONE (315)638-1300 • FAX (315) 638-0333



P.O. Box 1000 • Baldwinsville, NY 13027

READER SERVICE NO. 4

FREE



**SSAC**  
SOLID STATE TOWER CONTROLS  
Flashers  
Alarm Relays  
Photo Controls  
Shorted Flasher Alarms  
3 Phase Voltage Monitors  
PO Box 1000 • Baldwinsville NY 13027

## Attention Advertisers

Reach 22,000+ broadcast equipment buying prospects at AM, FM and AM/FM radio stations, networks and groups, recording studios, engineering and consulting firms every month.

Products & Services Showcase appears monthly in Radio World.

To advertise your product or service, contact Simone Mullins at

## RADIO WORLD

P.O. Box 1214  
Falls Church, Va 22041 USA

Tel: 1-800-336-3045



FAX: 703-998-2966

PRODUCT EVALUATION

## Tannoy Near-Field Monitors Score Well in Test

by Bruce Bartlett  
with Jenny Bartlett

**ELKHART, Ind.** If you need an accurate, detailed monitor that plays loud, without being too big, consider the PBM 6.5 II from Tannoy, a British firm that's made audio products since 1926.

Product Capsule: <b>Tannoy PBM 6.5 II</b>	
 <b>Thumbs Up</b>	 <b>Thumbs Down</b>
<ul style="list-style-type: none"> <li>✓ Very good tonal balance; uncolored, not boomy</li> <li>✓ High sensitivity and great dynamics</li> <li>✓ Clear and transparent</li> <li>✓ Stereo image is well focused</li> </ul>	<ul style="list-style-type: none"> <li>✓ Weak deep bass, which is normal for small speakers</li> <li>✓ Not signal-aligned, but this saves cost</li> </ul>
<p>For more information, circle <b>Reader Service 53</b>; or call Tannoy at 519-745-1158.</p>	

In size, the PBM 6.5 II is halfway between a mini monitor and a bookshelf speaker. Each unit is just over a foot high, 8.5 inches wide and deep, and weighs about 12 pounds. List price is \$450 per pair.

### Coaxial drivers

Although most Tannoy monitors use coaxial drivers for sharpest imaging, the 6.5 II uses two separate drivers to cut costs. The woofer has a 6.5-inch cone of stiff, light plastic that reduces distortion and smooths the response. A long-lasting rubber surround suspends the cone.

To aid power handling, the 0.75-inch plastic-dome tweeter is ferrofluid cooled. It is flush mounted to prevent cabinet reflections that can degrade the response. The crossover uses audiophile-grade capacitors, and is securely mounted to prevent microphonics. Magnetic shielding is available for an extra \$75.

I was impressed by the speaker's clean construction. The grille is made of stretched black fabric over a wooden frame. Finished in pewter gray vinyl, the high-density wood cabinet walls seem reasonably inert when you knock on them. On the back of the cabinet is the port, as well as two gold-plated binding posts, all of which makes for very easy access.

As for published specs, Tannoy rates the sensitivity as 90 dB/W/m, which is high for a monitor this size. The 6.5 II can play very loud when driven with a modest amplifier. Recommended power is a hefty 100 W peak. Frequency response is rated at 54 Hz to 18 kHz  $\pm 3$  dB—quite good—and impedance is 8 ohms.

### Listening tests

I set up the speakers just behind a mixer, 4 feet apart and 4 feet from me, and aimed them straight ahead. Then I listened to a variety of CDs and master tapes. Below are impressions of four representative CDs. These opinions reflect my own tastes, and are not an endorsement or critique by **RW**.

Listening to Donald Fagen's *Kamakiriad* (Reprise, 9 45230-2), I hear

a neutral character, an even tonal balance, but with slightly emphasized highs. Excellent clarity and detail. Bass is not muddy or tubby. The Tannoys get quite a bit louder than the Audix MM-15s (see **RW**, April 20), and have a slightly more forward upper midrange—better presence. Cymbals sound crisp and clean.

Moving to a rock album, *Reckless* by Bryan Adams (A&M, CD 5013), the sound is clear but not harsh. Deep bass is weak, but these are small speakers. Powerful percussive impact; these Tannoys really kick!

Shifting gears to a classical selection, the beginning of Stravinsky's *The Firebird* (Telarc, CD-80039) includes a very deep bass-drum roll that is only hinted at. To hear the deep bass in your mixes, you might want to augment the 6.5 IIs with a subwoofer or some good headphones. String tone is velvety but not veiled. In fact, it's just a bit forward or harsh. Flute is a little too breathy. The sound is so clear and detailed, you can hear individual timpani hits in a roll. Very impressive dynamic range and overall realism.

Finally, the Tannoys make the Holly Cole Trio's *Blame It On My Youth* (Manhattan, CDP7 97349 2) sound transparent and present—an open sound. Deep lows are missing. Holly's vocal has an accurate timbre—not too warm, not too thin.



Tannoy PBM 6.5 II

### Measurements

Using a Techron TEF-20 sound analyzer, I measured the anechoic frequency response of the 6.5 II. The mic was 1 meter away and 20 degrees off-axis, where the response was flattest. The response is 85 Hz to 20 kHz  $\pm 3$  dB. It's basically flat, which is highly desirable. But there is a 2.5 dB dip around 4 kHz and a 3 dB rise around 13 kHz. Bass is strong to about 85 Hz, and is down about 13 dB at 60 Hz.

This is the response in full space; the bass would be stronger if the loudspeaker were next to a surface such as a mixing console. The high-frequency response varies only a little on- and off-axis, so you can sit anywhere and hear crisp sound. According to the measured Energy Time Curve, transient response is good but not outstanding, as the woofer signal is delayed about 0.1 millisecond after the tweeter signal.

The stereo images of the Tannoys are well focused. The speakers have a wide

sweet spot—a large area of good reproduction. What's more, they are rugged, fairly compact and convenient to connect.

□□□  
Bruce Bartlett is a microphone engineer and technical writer for Crown International and a loudspeaker review-

er for High Performance Review. Jenny Bartlett is a technical writer. Bruce can be reached at 219-294-8388.

For information from Tannoy—TGI North America Inc., contact Mark Kinzie in Ontario at 519-745-1158; fax: 519-745-2364; or circle **Reader Service 53**.

# QEI

## meets all your FM broadcast transmitter needs.

### Selection

- 10 Watt - 1250 Watt Solid State
- 1 kW - 30 kW Single Tube
- Choice of Single or Three Phase Power Supply on 3.5 kW to 30 kW models

### Service

- 24-Hour Service Hotline: (609) 728-2020
- **Free** Initial On-Site Checkout for FMQ-Series Transmitters
- **Free** Spare Parts Kit with every FMQ-Series Transmitter
- Extended PA Tube Warranty—the **only one** in the Business

### Reliability

- Ultra-Low Maintenance
- Single Tube Design Eliminates Driver Tube
- No Sliding Contacts—Avoids Wear-Out
- Positive Pressure Cabinet to Prevent Dust Infiltration

### Experience

- Over 20 Years of Field-Proven Designs
- RF Products for Broadcast, Scientific and Military Applications
- Total In-House RF Design and Manufacturing

Learn more about the finest FM broadcast transmitters in the business. Call Jeff Detweiler today **toll free—(800) 334-9154**.

**QEI Corporation**  
One Airport Drive • P.O. Box 805  
Williamstown, NJ 08094

Tel: (800) 334-9154  
Fax: (609) 629-1751  
24-Hour Service Hotline  
Tel: (609) 728-2020

## USER REPORT

# ATI NanoAmp Mixers Ease Remotes

by Tom MacDonald  
Remote Engineer/News Reporter  
WWDB(FM)

**PHILADELPHIA** When buying a new piece of equipment, you have to make an important decision—is this for the rack or the road? With the new **Audio Technologies Inc. (ATI) NanoAmp** series, no decision is necessary, it can be for both.

Recently, I received a seven-input configuration of the NanoAmp, MX-100/XP-100 fresh from the factory. This unit will be used for some of the remotes that are part of everyday life at WWDB(FM). As an FM news/talk station, sound is an important consideration, and the NanoAmp has no problems in that department, with 0.1 percent maximum distortion, 20 Hz to 20 kHz at +20 dBm.

### Fits in briefcase

Another consideration is size. We go just about everywhere the news is, and I need to keep my remote gear small enough to fit into a briefcase. The MX-100 is perfect because it is only 1.75 inches high by 5.6 inches wide by 5.75 inches deep, and has its own optional desk stand or rackmount, depending upon your application.

One problem with small mixers I have used in the past has been a lack of inputs. Not the MX-100. With its modular construction, you can have three inputs with the base unit, or add modules and put up to 11 inputs in a one-rack space mount, with up to 23 inputs available with no noise problems. This is a setup that handles even the biggest of PA jobs without a problem.

The price of the MX-100 is also an advantage. This mixer is cheaper than something twice its size for the number of inputs.

Although it is compact in size, the NanoAmp acts like a big mixer. Instead of a microscopic VU meter, the unit uses an LED bar graph that is easily visible from across the room. The knobs are large and move freely. The unit also comes with different color knob inserts,

which I found particularly useful, because I use different color mic cables. Each insert is matched to the cables, allowing for easy recognition of what input matches each mic.

The inputs are front panel mic/line switchable, with a pushbutton switch that allows a change from mic to line input in seconds. That's more important to me when it comes to changing from a mic to a cassette on the road for interview playback.

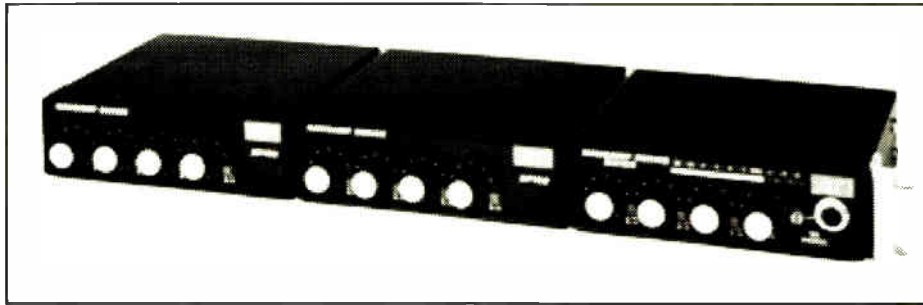

ATI's NanoAmp Series

The manual is easy to read, in fact, ATI should market the book as a comedy guide for engineers, it's a laugh a minute.

I first used the MX-100 at a fixed remote where space was a real consideration and the other mixer simply took up

too much space in a doctor's office. The MX-100 was great, it took up about one-tenth of the space of the former mixer, and its 24 V phantom power worked flawlessly. Yes, the MX-100 includes phantom power, available by moving an internal jumper.

### On the road

The "fixed remote" test is an easy one to pass for many mixers, but the "road"

remote test usually reveals its shortcomings. Throughout my years in this business, I have traveled to Israel, the White House and Disney World, among other places, and without fail, upon my return, I find the baggage handlers have managed to shake

something loose from the PC board.

But packing the MX-100 for a road trip to Disney World was a breeze. It survived the trip to and from Orlando, Fla., without even a scratch, although my luggage did not. The anvil case I use as checked baggage was covered with dents and scratches, but the MX-100 was perfect. This is one rugged package.

I also use the MX-100 for field news gathering. More and more the radio news field requires perfect mixes of ambient noise and soundbytes in the field. During the recent bad weather that left people slipping and sliding in the northeast, the MX-100 worked like a charm. I used the versatility of the mic/line inputs to put two cassette machines and my own voice together in a piece for ABC Radio that was quite well received.

The MX-100 is not the perfect mixer, but it comes close. It would be nice to have a switchable output, but size limitations allow only for line out. And it does not have a tone generator, but an outboard generator fits in a pocket.

All in all, this is probably one of the most rugged, dependable and versatile mixers I have used in a long time. It will be part of my remote bag, and a few racks, for a long time to come.

□ □ □

For information from Audio Technologies Inc., contact Sam Wenzel in Pennsylvania at 215-443-0330; fax: 215-443-0394; or circle Reader Service 30.

## USER REPORT

# AKG Mics Record for Radio

by John Moran  
Digital Services Recording Studios

**HOUSTON** I was somewhat surprised when RW asked me to review the AKG C391B, part of AKG's Blue Line series of microphones. I consider this microphone more of a music recording microphone rather than one for broadcast applications. However, after a quick review of my experiences with 391s, I realized I used the 391 on a lot of productions that were specifically for radio.

A pair of the C391B cardioid and companion pair of C390B omni microphones were acquired by Digital Services for recording Houston Grand Opera performances for local broadcast. Mandatory in a

live opera performance with a viewing audience is a low visual presence and minimal impact on complex lighting changes. Also, the need to occasionally work in darkened halls during audio setup required simplicity and reliability of the hardware under low light. It goes without saying that audio quality had to be of the highest order.

### Modular system

The 391s are a modular mic system with the basic preamp body and an assortment of mic capsules including cardioid, omni, hypercardioid patterns and a shotgun capsule. These mics have three distinguishing physical characteristics:

- The capsules have the same metal as the mic body, extruded around the nor-

mal metal screen over the capsule, providing an extremely well-protected capsule arrangement. It is possibly the toughest I have seen in any small diaphragm mic.

- There is a pattern of slots on the side of each capsule that indicate by number of slots the pattern of the capsule, i.e., 1 slot for omni, 2 for cardioid, in addition to a screen visual sign on the capsule.

- The capsules attach to the mic bodies by a plug-in bayonet connector made of heavy metal in a tongue-in-groove arrangement that cannot crossthread and locks in one turn with an audible and physical click.

Working in darkened halls, physically identifiable parts that snap together simply and reliably—as well as survive the rigors of live production—is a good thing. The 391s use an active capsule, transformerless design, which gives them

continued on next page ►

First class quality

First class performance

Incredible price! -- \$995\*

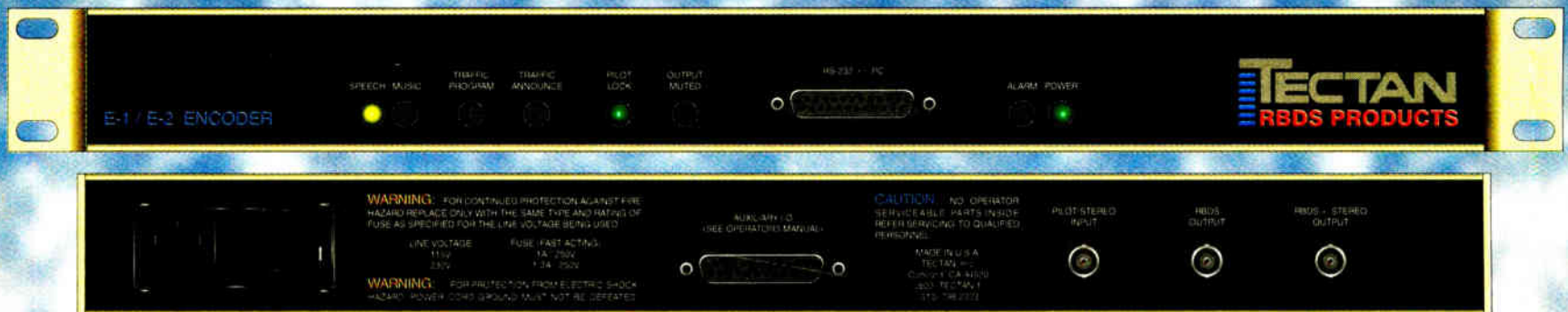

No-compromise RBDS just became affordable!  
Phone 1-800-TECTAN-1 for details.

\* Limited time introductory price for E-1 Encoder. Introductory price for the E-2 Encoder is \$1195. Shipping & handling \$25 additional for 2-day air shipment anywhere in the U.S.A.

# AKG Mics Record Texas Symphony for Broadcast

► continued from previous page  
many options in configuration hardware with more to come as AKG leans more heavily on this line with the demise of the venerable 451 series.

For my needs, the very thin extension hanging cables and hardware were an absolute necessity over conventional microphone cables because of the visibility of different cable diameters. The Houston Grand Opera was very critical. The AKG stereo bar for the 391s seemed flimsy and not stable enough for our applications.

Our array was hung with the center pair of capsules on an ORTF bar we built using the AKG hanging clips and some minor machine work, and one omni capsule on either side of the center pair, with the mic bodies and XLR-3 cable connectors elevated out of the audience's line of sight, making the mics unnoticeable from the house. There are slightly smaller capsules from other manufacturers, but they did not offer the assembly simplicity and armor of the 391s.

## Sonics

Sonically, the 391s sound like AKGs tend to sound: clean, bright and present, with a taut bass. Given that our program was intended for broadcast, and because the material was orchestra with operatic vocals, the presence lift of the 391s was useful, particularly with the varying stage distances when actors moved.

The balance with the 391s on the orchestra was very clean, with no brittleness in the strings and good warmth on the brass. Percussive response was tight and the hall presence on the omnis was well-defined and coherent. Imaging was very accurate off the ORTF pair, with smooth, balanced motion of actors' stage movements across the stereo spectrum, and, on good monitors even some vertical imaging.

High compliments came from several orchestra members after hearing the broadcasts, so the 391s really did their job well.

In the studio, another engineer here, Roger Tausz, used the 391 cardioid pair in an XY arrangement to record a five-part vocal background part. The overriding comment from Roger was, again, the remarkable imaging he felt he received in the stereo configuration. This is interesting, given that AKG does not specifically make a matched stereo pair set of the 391s.

Everyone was quite happy with the vocal tone. The standard use of these mics for drum overheads and high hat is quite

acceptable, and Roger also reports a very good result on solo acoustic guitar. The only failure experienced was one of the hanging cables lost continu-

ity and was replaced. The microphones performed flawlessly electrically and mechanically. One of my favorite studio tricks now is to take the 391

apart and put it together behind my back with my eyes closed. It never fails to get someone's attention in a hurry, and then they want to hear it.

My only regret is that I have not been able to try out the shotgun capsule. However, summer is coming, which means a new remote recording season and new excuses for trying out gear.

□ □ □

For information from AKG, contact Amy Herndon in California at 510-351-3500; fax: 510-351-0500; or circle Reader Service 25.

**High compliments came from several orchestra members after hearing the broadcasts, so the 391s really did their job well.**



The original Shure FP32 set the standard in field production for portable stereo mixers. Now, with the new FP32A, you can count on getting even less. Noise, that is...30dB less! In fact, the FP32A is so quiet and improved that it's perfect for use with DAT and other digital recording media.

## Professional Mixing You Can Take Anywhere.

The Shure FP32A is a 3-input, 2-output portable mixer specifically designed for:

- remote audio recording
- electronic field production
- electronic news gathering
- location film production

The FP32A weighs just 3.5 lbs and is only 2-1/4" H x 6-3/8" D x 7-1/4" W in size.

**FP32A**

**PORTABLE  
STEREO  
MIXER**

With 8 hours use from two 9V alkaline batteries — or powered by any 12 to 30 VDC source — the FP32A goes wherever you do. And since it's from Shure, you can count on its durability and ruggedness.

## So Many Features In So Little Space.

You get all the features of the original FP32 plus:

- 48V phantom power
- pop-up pan pots
- input level LED indicators
- mix bus jack and cable
- headphone mode switch
- mixer/monitor switch
- adjustable peak output LEDs
- stereo link for inputs 2 and 3
- more than 30 other new features and improvements

So go to your nearest dealer and pick up an FP32A. Once you use it, you'll see why we're making so much noise about something so quiet.

**For the Shure FP dealer nearest you, call 1-800-25-SHURE.**

**SHURE®**

The Sound of The Professionals®...Worldwide.

# EVERYBODY TELLS US THAT BROADCAST ENGINEERS ARE VERY CONSERVATIVE. OKAY. READ THIS AD NOW AND THEN BUY A CR-1604 IN FIVE YEARS.

**W**e understand why broadcast engineers have a wait-and-see attitude about new products. Your station (and your job) depend on rock-solid reliability and sonic performance you can count on.

We'd like to introduce you to Mackie... even if we do probably seem like a wet-behind-the-ears newcomer compared to some manufacturers. We've been around six years now. During that time we've gained a serious reputation for building high-value, trouble-free mic/line mixers.

Mixers with legendary headroom, ultra-low noise and unique features that make using them easier.

Mixers so good that they're regularly used to create major label compact discs, feature movie soundtracks, and more commercial production work than you can shake an RE20 at. For example, our CR-1604 16-channel mic/line mixers are used nightly on the Tonight Show, Arsenio Hall, Conan O'Brian and David Letterman Shows<sup>1</sup>.

Our mixers have also covered hundreds of thousands of miles with acts like Peter Gabriel, Madonna, Whitney Houston, Paula Abdul, Bruce Springsteen, Reba McEntyre, Alabama and Michael Jackson<sup>1</sup>. Compared to the relative security of a station production room, a six-month world tour is about the most brutal test that any electronic component can go through. Our mixers have a reputation for being bullet-proof on the road — even when loading dock mishaps and power surges have taken out everything else in the same rack.

As for use at broadcast facilities, well, we're not total newcomers. A quick scan of our warranty database shows that over 70 U.S. radio stations already have Mackie mic/line mixers in place.

Does that mean you folks aren't as conservative as everybody says? If so, call your favorite broadcast supply house, or dial us toll-free for complete information on Mackie's line of mixers.

If you are conservative, keep an eye on us, anyway. We want your business even if we have to wait five years.

<sup>1</sup> Mention in this ad denotes documented usage only. Mention is not intended to infer endorsement by any of the television shows listed.

<sup>2</sup> Price is slightly higher in Canada.

**3-band equalization** done right:  $\pm 15\text{dB}$  at 80Hz,  $\pm 12\text{dB}$  at 2.5kHz (perfect for voices),  $\pm 15\text{dB}$  at 12kHz. Far more useful than traditional 100Hz, 1KHz, 10KHz EQ.

**Sealed rotary potentiometers** resist contamination from dust, liquids and smoke. Plus they have a smooth, positive feel without a trace of wobble.

The Mackie Designs 16x2 CR-1604 Mic/Line Mixer. Suggested retail price, \$1095<sup>1</sup>. Available at America's top broadcast supply houses.

**Six recording studio-grade microphone preamps** with +48VDC phantom power. Discrete circuitry with four conjugate-pair, large-emitter geometry transistors delivers  $-129.6\text{dBm}$  E.I.N., 300K bandwidth, 0.005% THD...and incredible headroom. A Very Famous Maker of Expensive German Microphones uses a CR-1604's preamps to demo their mics at tradeshow.



**Solid steel main chassis.**

**Individual channel signal metering** via solo function.

**Two extra buses.** Mute buttons route the channels' signals to an extra stereo bus called ALT 3/4. Because you can also route ALT 3/4 to the headphones, it's perfect for monitoring advance audio cues: Preview a signal that hasn't been brought up in the mix yet...then add it by unmuting the channel.

**UnityPlus gain structure** gives high headroom and low noise at the same time. Set the fader to center-detent Unity Gain, press channel solo to monitor the channel via the CR-1604's LED meters, adjust the input trim ONCE, and you're ready. Because there's 20dB MORE gain available on the fader, you

won't need to constantly re-adjust the trim.

**Maximum RF protection.** Most compact mixers use plastic jacks that transmit RF to the main circuit board where it's re-radiated and picked up by anything that rectifies (A). The CR-1604 uses metal jacks and washers plus a shunting

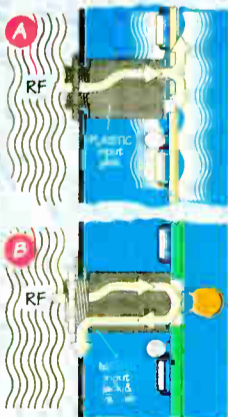

capacitor to de-rail RF before it gets to any circuit traces (B). A Radio World reviewer tested a CR-1604 on a transmitter hill with 3 VHF TV and 1 FM sticks plus several microwave repeaters and shortwave transmitters. When he plugged in a notoriously RF-prone microphone, he detected NO RF.

**Not shown:** Inserts on Chs. 1 thru 8, main left/right bus inserts, phantom power switch, balanced/unbalanced main stereo outputs and separate mono output. XLR10 Mic Preamp Expander connects to the CR-1604 pod to provide 10 more preamps complete with trims and phantom power.

**7 AUX Sends** from four knobs. AUX 1 can be used as an effects send or headphone monitor cue via the MON. Sends 3 & 4 become AUXs 5 & 6 when the SHIFT button is pressed. All sends give you 15dB more gain above Unity so that you can get tons of effect even when the channel fader is pulled down.

**Powerful headphone amp** (with volume control) drives any phones to head-banging levels even an AOR production person will appreciate.



**A chip off the old block:** Perfect for remotes, our MS1202 12x2 Mic/Line Mixer has 4 of the same superb mic preamps that distinguish our larger CR-1604, plus phantom power, 2 AUX sends/ch., 2 stereo AUX returns, channel patching, 2-band EQ, 3-way 12-LED peak metering, headphone monitor amp with level control, built-in power supply. Suggested retail is just \$399<sup>1</sup>

**8 mono or 4 stereo AUX Returns** with individual level and balance controls. All have 15dB additional gain above Unity to boost weak effects.

**Unique, multi-way convertible physical configuration.** CR-1604's input/output pod rotates to back (creating a space-saving 7-rack-space mixer shown in Fig. 1), or to front (10 rack spaces, shown in Fig. 2) with our optional RotoPod bracket. Use the CR-1604 on a tabletop with jacks on the same plane as the controls via the RotoPod bracket (Fig. 3 below), or jacks to top (Fig. 4 below). Our XLR10 Mic Preamp

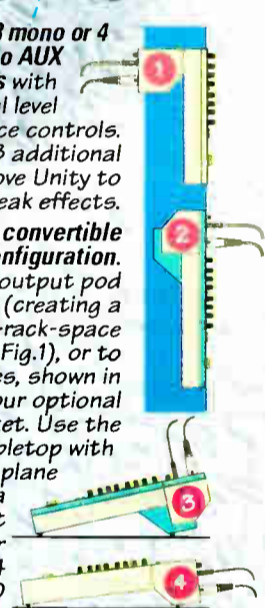

Expander can also be added in any of these configurations.

**Rugged design and construction.** Including mil-spec, double-sided, thru-hole-plated fiberglass circuit boards (horizontally-mounted on brass stand-offs for impact-resistance), double-parallel-wired faders for 2-times redundancy, and electronic protection against power surges, impedance mis-matches and static discharges.

**Better-than-digital specs and headroom.** The CR-1604 has a dynamic range of 108dB and an internal S/N ratio of  $-116\text{dB}$  (versus compact discs' 96dB dynamic range.) This means you're getting a mixer that can handle the output of digital workstations, CDs and DAT tapes without overload.

# MACKIE.

MACKIE DESIGNS INC. • 20205 144<sup>th</sup> Ave NE • Woodinville, WA • 98072 • 800/898-3211  
FAX 206/487-4337 • Outside the U.S. call 206/487-4333 • Represented in Canada by S.F. Marketing 800/363-8855

Circle (184) On Reader Service Card

USER REPORT

# Yamaha Monitors Give Accurate Sound

by Fred Guarino  
Tiki Recording Studios  
Owner/Engineer

**GLEN COVE, N.Y.** As in any trade, there is one tool that is vital to the successful outcome of the end product. In the recording studio, it is the playback monitors. As engineers, we rely on and trust them to give us a clear picture of what really is going to tape.

The Yamaha NS-10M Studio monitors have become a standard in the recording industry for near-field monitoring. NS-10Ms are mounted on top of consoles around the world. At Tiki Recording Studios, we have used NS-10M Studio monitors in all three studios for years. These monitors are not new to the recording community; however, an introduction for the broadcast industry might be in order.

**Important features**

Instead of displaying frequency response charts in an anechoic chamber, I would rather present the features in an "ears on" manner from the control room. The important features are: compact size, near-field design, consistency, flat response, big sound, accurate imaging, ease of service and, most importantly, mix results.

By recording and mixing with NS-10M Studio monitors, we have found that our mixes sound good out in the real world on all types of consumer playback systems. This is a difficult task for any monitor. To make an analogy, if a camera lens is out of focus, so is the picture. The same holds true for studio monitors. We must make sound judgments through true, in-focus monitors and the NS-10M Studios translate well to the outside world.

The NS-10M Studios are compact: 15 inches high by 8.5 inches wide by 7.875 inches deep. They were designed for near-field monitoring. The benefit of this type of monitoring is that room acoustics do not play a major role in the sound. This is a plus for broadcast situations in a room that is not perfectly symmetrical, non-parallel or non-trapped.

Many engineers feel comfortable with near-field monitoring and especially with NS-10M Studios because they are so consistent and familiar when traveling from studio to studio. I constantly see outside engineers try out the large main soffit mount monitors during a session. They leave them on for about five minutes, then switch back to the familiar NS-10M Studios. The engineer can then concentrate on the program material without worrying about the monitor itself.

You can compare the published specifications of other monitors. They may claim to be flat and have tight imaging. But when sound tests are performed, chances are you will find otherwise. When listening to the NS-10M Studios, many engineers agree that the sound is tight and punchy. The frequency response is flat from 60 Hz to 20 kHz. There is no boominess in the lows, no artificially colored highs. Instead, the highs are sparkling and true, not to mention the transient response, which is also excellent.

The 7-inch woofer has good dampening, especially after long kicking excursions. The 1.375-inch dome tweeter projects a huge midrange as well as the crystalline highs. The overall sound seems to jump way out beyond the cabinets.

**Big sound**

Quite often Tiki clients think we are listening to our large monitors when the NS-10s are actually on. It's a great trick to play. The big sound is due in part to the non-ported, acoustic suspension cabinet design. Yamaha engineers were able to successfully optimize the cabinet tuning to the speaker components.

I prefer the two-way speaker design of the NS-10M Studio. There is less to confuse the ears with. In three- or four-way monitors, design and construction are critical in order to keep imaging and timing acceptable. When the listener does not hear all components and their associated frequencies at the same time, the result is time smear. The imaging on the NS-10M Studios is extremely accurate. Center images are tight dead center at all frequencies. Off-axis listening is also very good.

The NS-10M Studios are not shotgun speakers. If a listener is off to one side of the pair, a good sense of stereo can still be heard. Our Trident TSM consoles are 12 feet long, which makes it impossible for everyone to be positioned ringside.

**Plenty of power**

The NS-10M Studios handle plenty of power. It seems that many people use huge amplifiers to feed them, but that is not absolutely necessary. A good quality 75 to 100 W per side amp into 8 ohms should be fine. However, I recommend going to a local electronics supply shop and getting a pair of in-line fuse holders with 1.5 amp fuses. It's better to be safe than sorry.

But beware of the late night engineer who accidentally blows a fuse and cannot find any 1.5 amp replacements and puts a three amp fuse in instead. This is

like leaving a time bomb for the morning guys. It's happened at Tiki Recording Studios before.

Servicing these monitors is simple. I just wish that Yamaha would build them with built-in fuses.

Engineer Mark Gaide has been mixing on the NS-10M Studios at Tiki Recording Studios for the past 11 years and he still trusts them. Every now and then he checks out another pair of monitors, but he always returns to Yamaha.

Another Tiki engineer, Lloyd Kozel, has had retail experience selling various monitors. As he puts it, "Customers

who purchased competitive monitors based their decision on hearing a HiFi sound rather than a flat, uncolored studio monitor sound such as the NS-10M Studios. Many returned complaining that their mixes came out dull and uneven."

Yamaha NS-10M Studio monitors are pumping out true, uncolored sound, day and night, seven days a week, in Tiki Recording Studios and in all types of facilities all over the world. By doing their job, they have earned an enviable reputation as a world standard. They are true workhorse studio monitors for the real world.

□ □ □

For information, contact Yamaha Corp. of America in California at 714-522-9011; fax: 714-739-2680; or circle Reader Service 168.

## I COULD HAVE BOUGHT A DIGILINK!

Are you thinking about replacing your old cart machines with 'Digital Carts' such as floppies, flopticals, Bernoullis, or Opticals??? Well, think about it a little more! Add up the list price for a digital cartridge recorder, just a single player, AND the floppy disks--- and you will find that you could have bought a Digilink workstation for \$7,995 that gave you 'Live' -AND- 'Automation' capabilities!!!

A Digilink workstation stores audio on an internal hard disk and comes out of the box with a capacity of 547 one minute, stereo carts for only \$7,995. Even better, the Digilink hard disk has an average 15 year life. Imagine how many floppies you will break, wear out, lose, and replace over 15 years. That doesn't count all of the floppy disk mechanisms that will jam, break, and simply fail...

Consoles  
Modulux  
Trak\*Star  
Digilink  
Modulink

Also with a Digilink, you get much more! You can stack up hundreds of 'carts' in the play list and just walk away. You get satellite automation in the Digilink workstation and can optionally add CD players. A digital audio cut and splice editor even comes standard with Digilink. Because Digilink will play and record at the same time, you can play a spot to air while it starts a scheduled network autorecord. You can even network delay with Digilink.

With all of these features, it is easy to see why there are more than 500 Digilink workstations around the world from Paris to Moscow to Taiwan to Jamaica and in your own backyard. Don't suddenly come to the realization that you could have bought a Digilink! Call Arrakis now... (303) 224-2248

### ARRAKIS

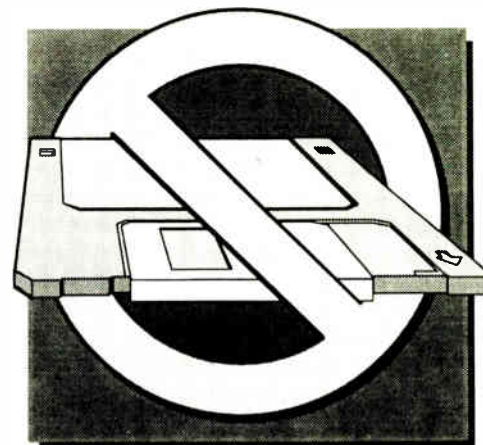

© 1993 Arrakis Systems Inc. 2619 Midpoint Drive, Fort Collins, CO. 80525

Circle (205) On Reader Service Card

### Buyers Guide Calendar 1994

**June 15**

Audio Processing

•

**July 13**

Automation Equipment & Software

•

**August 10**

Consoles, Studio Components & Furniture

•

**September 7**

MIDI Production Gear

# Products & Services Showcase

For more information on the products shown below, circle the appropriate Reader Service No. (s) on the enclosed Subscription/Reader Service card or contact the advertiser directly.

**Uh-Oh . . . We Should Have Called CORTANA**



**STATI-CAT for Affordable Lightning Prevention.**

Let Us Design a System for You

Stati-Cat provides a continuous, low-resistance discharge path for the static electric charge on tall structures. Dissipation points are 1/8", type 304 stainless steel rods ground to needle sharpness. They won't bend, not even from ice and severe weather.



Write to us today for a **FREE** brochure!  
P.O. Box 2548, Farmington, N.M. 87499  
Call (505) 325-5336 FAX (505) 326-2337

**READER SERVICE NO. 170**

**Need a New Digital Satellite Receiver for DATS/"SEDAT"?**

New DATS 7.5/15?  
New 3.5 Voice Cue?  
"SEDAT" Cards?  
We are shipping now! We can even convert your S/A 7300/7325!



*Ariel*

Used Equipment for All Satellite Formats LNA/LNB/Splitters

Zephyrus for JSA  
Zephyrus 700 SCPC



**Satellite Systems**  
(719) 634-6319

We Repair & Rebuild all Popular Receivers Quick Service! 24 Hour Tech Support

SEDAT is a trademark of Scientific-Atlanta, Inc.

**READER SERVICE NO. 167**

**Digital Dream System \$9,995.00!**

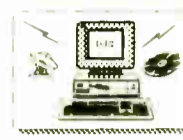

Just \$9,995.00 for this dual digital audio Satellite control with Production system. You get two powerful 486SX-25 computers, VGA color monitors and 535 meg hard disk (9+ hours mono storage), LAN and DMX-4 audio switcher. Includes interface and control hardware. Nothing else is required! This pricing is good for a limited time.

- Great Sound: Premium apt-X™ audio card standard
- Simultaneous record play for *time shift* PBR recording
- Separate Production room system with LAN net connect to Control for complete backup & safety.
- Satellite system handles all standard formats
- CD system option from \$1,500 uses Pioneer single or triple 6 packs or 300 disc *jukeboxes*
- Live assist included, ready for Traffic & Music interfaces
- Many options: External button boxes, more audio & I/O

**The Management**  
1-800-334-7823 1-817-625-9761 FAX: 817-634-9741  
P.O. Box 1-36457 Ft. Worth, TX. 76136  
*1600+ Stations - Our 13th year*

\* Extra charge for combined Satellite & CD systems. No holds or splits, larger hard drives available at extra cost.

**READER SERVICE NO. 212**

**Shape Up!**

Coverage. Saturation. DBk contours. In FM broadcasting, the "bottom line" is always based on your pattern.

More than any other manufacturer, Shively has the experience and reputation for providing crucial pattern solutions for critical propagation problems. On any tower. At any power level. Remember, *it pays to be heard.*

A good pattern. The shape you need. Talk to your consultant. And contact us.

**Shively Labs**  
A Division of Howell Laboratories, Inc.  
19 Harrison Road, Bridgton, ME 04009  
207-647-3327 FAX 207-647-8273

**READER SERVICE NO. 20**

**Wizard for Windows**  
*The Premier Digital Audio System Designed by Broadcasters*

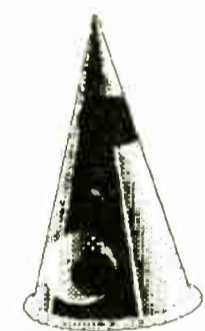

**Wizard for Windows features:**

- Windows & Novell Network Technology
- Fully Integrated Copy Editing: on screen copy production
- Hard Drive & CD Automation
- Block Stretch/Squeeze: insures that spot blocks time to the right length every time for seamless integration with satellite services

**Prophet Systems**  
1-800-658-4403

**READER SERVICE NO. 32**

**Big Voice!**  
Small Price...

**New! Model 401 Mic Processor**

Specially designed to enhance the power of an on-air or voice-over announcer, the Valley Audio Model 401 Microphone Processor is a high performance update of the industry standard Model 400, with 48V phantom power built-in.

**Nothing Sounds Better!**

- Quiet wide dynamic range mic preamp.
- Internal phantom power for condenser mics.
- 3-band EQ with voice-tailored frequencies.
- The industry's best sounding compressor.
- Interactive expansion/gating for noise control.
- Normal or heavy duty "D-S" sibilance control.
- Multiple input, output and insert connections.
- New easier-to-read control function graphics.

Call for more information!



**Valley Audio**  
9020 W. 51st Terrace  
Merriam, KS 66203

**1-800-800-4345**

**READER SERVICE NO. 104**

**"ITC" The Only Affordable Spectrum Analyzer**

**THREE FULL FUNCTION ANALYZERS TO CHOOSE FROM 600 MHz - 1000 MHz - 1800 MHz**

**80 dB ON SCREEN DYNAMIC RANGE.** With ITC's Exclusive EFPLA Log Amp. (pat.pend.)

**-110 dBm SENSITIVITY AT ALL SPAN WIDTHS.** ITC Analyzers have -110 dBm .7uv. sensitivity at all Resolution Band & Span widths.

**HIGH STABILITY** (<1KHz per Hr. after warm up)

**FEATURES** Baseline Clipper, Video Filter, 5" CRT, Preset plus variable Dispersion settings from 0 - 50 Mhz per/div, 100:1 tuning ratio for easy Center Frequency selection, & More.

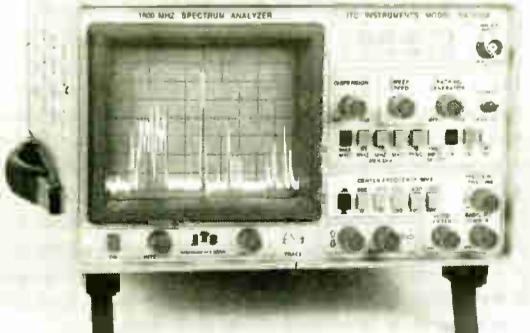

**ITC INSTRUMENTS**  
9222 Chesapeake Dr. Suite A  
San Diego Ca. 92123 USA  
**MADE IN THE USA**  
TERMS: M/C, VISA, AE, CHECK, MO, COD, P.O. (OAC)

SA600A	600 MHz	\$1295.00	Opt.1 50 MHz marker	\$200.00
SA1000A	1000 MHz	\$1595.00	Opt.3 +/- 5 KHz Filter	\$350.00
SA1800A	1800 MHz	\$1895.00	Opt.5 Tracking Gen.	\$250.00
			Opt. 6 Center Frequency Display	\$275.00

**FOR MORE INFORMATION & INTRODUCTORY OFFER CALL 1-800-232-3501 619-277-4619 FAX-277-6736**

ITC Analyzers are the perfect low cost choice for All AM, FM Broadcast-VHF, UHF TV maintenance depts., and FCC compliance testing. You will save time & money with a ITC low cost Spectrum Analyzer.

**READER SERVICE NO. 107**



**ZEPHYRUS**

Quality, service, delivery, and reliability have come to SCPC

The Zephyrus 300 family of satellite subcarrier receivers is trusted by thousands of broadcasters. Carrying on the tradition of excellence (at a fair price) is our 700 series analog SCPC line. Entry of all operating frequencies is done on a front-panel keypad. "Old fashioned" meters monitor RF and audio levels.

**ZEPHYRUS ELECTRONICS, Ltd.**  
171 S. 122 E. Ave, Tulsa, OK 74128  
918-437-3333 Fax 918-438-7322

**READER SERVICE NO. 86**



## USER REPORT

# Broadcast Tools Eases Communications

by Dwight Small  
Chief Engineer  
KNDD(FM)

**SEATTLE** A few years ago, KNDD(FM) ran an AC format featuring a four-person morning show. The show originated out of two studios, with news coming from a third. An efficient means of communicating between the studios quickly became a necessity.

Fortunately, the Broadcast Tools SMI-5 studio intercom system had just been introduced. After reviewing several different intercom systems, I decided the SMI-5 appeared to be the most cost effective and flexible system.

## Headphone control

The unit itself provides intercom, monitor interface and headphone control. The air talent appreciates the last feature because it provides separate bass and treble controls for the host headphones. The intercom portion has four buttons with LED tally to call the other stations in the system. There are a total of five dedicated stations. There is an All Call function if all stations need to be paged.

**The connections to the consoles and monitors were fairly easy and done through 1/4-inch TRS jacks.**

When a station is called, the monitor audio dims and the intercom audio is routed to the called studio's monitor speakers. Dim level is adjustable via a front panel control. If the monitors are muted, the intercom is routed to the host headphones. In this case the program audio is fed to one ear and the intercom audio to the other. For a jock that finds this distracting, a Privacy control located on the front panel cancels this function. An LED indicates the privacy function is active. The separate guest headphone feed with independent level control does not have the intercom function.

The monitor portion of the unit provides a master level control plus a mono sum function. The mono sum feature is especially useful in checking phase. Also, there is a control that activates the dim function so that the dimmed monitor and headphone levels can be set.

The SMI-5 provides a mic-or-line input to facilitate the talk-back function. In our system, we used an external line output from the talent's mic to feed into the system. It made the operation easier for the jocks and provided better quality audio.

## Wiring

The wiring for this system is straightforward and is done with standard 25-pair telephone cable. The back of the SMI-5 has a standard 25-pair amp connector for the station cable. All of our intercom cables terminate in the engineering frame area on telephone punch blocks, with a block dedicated for each studio. Broadcast Tools provides an interface to facilitate the interconnection of each SMI-5, but we

elected to use punch blocks.

The intercom is like wiring a 1A2 telephone system with the units being cross-connected in this area. You can have more than five units and set the system up so that all units do not appear in all studios. In our case, the studios, news booth and engineering shop are connected. We plan on using the shop intercom to feed our remote IFB. This will allow each studio to communicate with the talent at a remote.

The connections to the consoles and monitors were fairly easy and done through 1/4-inch TRS jacks on the rear of the SMI-5.

In all of our studios, the monitor amplifiers are external to the console and interruption of the feed to insert the SMI-5 was easy. Our Pacific Recorders BMX provided a post monitor input selector feed for both the monitor and headphones.

In our Autogram consoles, we took the monitor feed from the monitor amp socket in the console. This is after the input select switch and volume control, so those console functions remain intact.

For headphones, we interrupted the headphone feed after the input select switch and returned the output of the SMI-5 to the headphone amplifiers to

provide intercom directly to the headphone jacks on the console. For remote control, there is a DB-25 connector on the unit's rear panel that brings out tally and control functions.

Reliability is always a concern in broadcast facilities. Our units have been in service for more than three years with no major failures and almost no maintenance problems. I can recall only one switch and a headphone jack that had to be replaced in that time. Our old AC format has been long since replaced by modern rock, but the Broadcast Tools SMI-5s still serve us well.

□ □ □

For information from Broadcast Tools, contact Don Winget in Washington state at 206-938-4089; fax: 206-938-4089; or circle Reader Service 56.

**YOU CAN SHARE PROGRAMMING  
AMONG YOUR RADIO STATIONS ...  
At a Lower Cost Than Ever Before!**

Share programming among your station group or with other stations by sharing day parts, entire formats or by delivering your top-rated talent to other markets coast to coast. You can spread overhead costs, increase the quality of programming at the local station and build your audience by creating a satellite radio network. And now new digital satellite technology makes radio networking more affordable than ever before. Let us offer you a complete solution for your radio networking needs.

**Call us at (202) 414-2626**

**NPR SATELLITE SERVICES®**  
Has moved to:  
635 Massachusetts Ave., NW, Washington, DC 20001-3753  
(202) 414-2626

# TECHNOLOGY UPDATES

## NADY

### Nady Snap-On Transmitter Module Makes Any Microphone Wireless

**EMERYVILLE, Calif.** The Nady ENG-12 snap-on transmitter module converts any microphone into a professional multichannel UHF wireless microphone.

The ENG-12 UHF is designed in a rugged, all-metal case, and provides a noise-free XLR connection for any microphone.

The ENG-12 transmitter utilizes state of the art frequency synthesis, and is available with up to 160 switchable UHF channels, assuring a clear operating channel in any location. The ENG-12 utilizes Nady's quiet RF link—up to 20 dB quieter

than other models—and patented companding for an unmatched 120 dB dynamic range, with no hiss or distortion. The ENG-12 and its compatible receivers feature tone squelch to eliminate interference from other services.

For broadcast applications, the Nady 661 VR portable UHF receiver is recommended. The 661 VR is designed into a compact, all-metal case, and is available with up to 160 switchable channels. The ENG-12 transmitter is also compatible with Nady's rack-mount multi-channel UHF receivers.

The ENG-12 provides a minimum 200-foot range in adverse conditions and up to 1,500 feet, line of sight.

For information, contact Howard Zimmerman in California at 510-652-2411; fax: 510-652-5075; or circle Reader Service 207.

## GENELEC

### Genelec 1030A Powered Monitors Well Suited To Broadcast Needs

**IISALMI, Finland** The Genelec 1030A is a fully powered monitor system, ideally suited for project studios, broadcast control rooms and smaller post production suites. It uses Genelec's DCW technology in conjunction with some of the finest driver technology available.

The woofer is a high-efficiency, 6.5-inch (170 mm) polymer composite cone, mounted into a 6.5 liter enclosure, measuring a mere 12 inches by 8 inches by 10 inches. The high frequencies are handled by a 0.75-inch (19 mm) metal dome tweeter.

The enclosure is constructed of a vinyl-sprayed MDF, and utilizes an unusually thick front baffle, resulting in a rigid, inert cabinet minimizing tonal coloration in the mid-band. The amplifier chassis is mounted into the rear of the enclosure on quick-release hinges, isolating the electronics from vibration.



While the Genelec 1030A is a compact unit, its performance belies its diminutive proportions. The low frequency driver produces clean tight bass down to 52 Hz (-3 dB), while the design of the HF driver ensures operation in the pure piston mode up to 25 kHz, well beyond the range of audibility.

Uniform dispersion control, precise imaging, low diffraction, optimum driver sensitivity and lower distortion are achieved with DCW technology. A pair of 1030As can produce peak sound pressure levels in excess of 115 dB at 1 meter from the engineer.

The 1030A also features controls for HF and LF sections, bass tilt control and active driver protection.

For information, contact Barry Fox at QMI in Massachusetts at 508-435-4243; fax: 508-435-3666; or circle Reader Service 12.

## CROWN AUDIO

### Head-Worn Cardioid Condenser Mic From Crown Provides Hand-Held Sound



**ELKHART, Ind.** The CM-311 differoid head-worn cardioid condenser mic from Crown Audio sounds like the best hand-held microphones—full, clear and free of distortion.

The mic features an electret condenser transducer and typical frequency response is 50 Hz to 15 kHz. SNR is 67 dB at 94 dB SPL. The unit is powered by a 9 V DC internal alkaline battery or 18 to 48 V of phantom power. Battery life is approximately 134 hours. The battery is housed in a belt pack that connects to a mixer or any wireless transmitter.

The CM-311/E version is the head-worn mic alone, ready for use with a 9-V wireless belt transmitter.

For information, contact Crown Audio in Indiana at 219-294-8000; fax: 219-294-8329; or circle Reader Service 62.

## BEYERDYNAMIC

### Transformerless Condenser Microphone Designed by beyerdynamics for Broadcasters

**FARMINGDALE, N.Y.** In 1986 beyerdynamic introduced the MC 740 large diaphragm studio condenser microphone, the flagship of beyerdynamic's Studiogroup condenser series. Many engineers who evaluated the MC 740 loved its ability to capture accurately any source, be it speech, vocal or musical instrument.

Many broadcast and recording engineers soon began to request a microphone of similar character but without the MC 740's five polar patterns and, of course, for a lower price. beyerdynamic responded by introducing the MC 834 transformerless condenser mic.

Featuring a single cardioid polar pattern and smooth, wide range frequency response from 40 Hz to 20 kHz, the MC 834 produces startling recording studio quality results for voice and music production. The transformerless design and ultra-low self noise electronic yields very accurate, low distortion pickup.

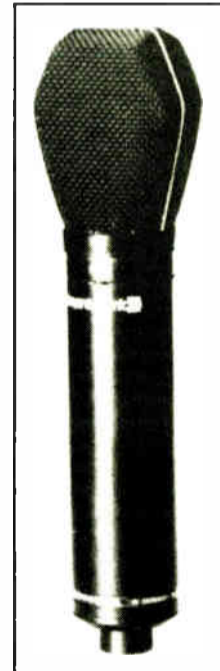

An on-board user adjustable three-position low frequency roll-off switch controls proximity effect via flat, no roll-off 6 dB per octave roll-off at 80 Hz or 6 dB per octave roll-off at 160 Hz. This is beneficial in adjusting perceived low-end on voice talent and can be reset for different on-air talent.

The mic also features a multiposition attenuation switch that can be used when mixing very high SPL sources, for example screaming DJs. A 10 dB pad is also accessible with a flick of a recessed switch built into the mic's barrel.

An internal blast filter reduces P-popping in closeup voice work. Optional accessories include an external windscreen, a popscreen and an external shockmount to further reduce undesirable windnoise or boom stand-generated vibration.

For information, contact Mike Soloman in New York state at 516-293-3200; fax: 516-293-3288; or circle Reader Service 37.

## NEUMANN

### With TLM 193 Microphone Neumann Takes Aim at Broadcast Market

**OLD LYME, Conn.** The TLM 193 from Neumann is a large diaphragm cardioid condenser microphone with state-of-the-art specifications.

Keeping in line with the design and pro-

duction values that Neumann has always used, the TLM 193 offers broadcasters a Neumann microphone for under \$1,300.

Specifications of the microphone include: frequency response of 20 Hz to 20 kHz, dynamic range of 130 dB, self noise of 10 dB-A and a maximum SPL of 140 dB.

For information, contact Jeff Alexander in Connecticut at 203-434-5220; fax: 203-434-3148; or circle Reader Service 109.

## RDS / RBDS

At CRL we've made it easy to begin RBDS Broadcasting. The SC-100 is all you need to get started today! Be a leader in your market with digital RDS/RBDS technology from CRL.

### SC-100 Features:

- Easy loop-thru installation with your existing processing system

- Two expansion slots for future DSP card upgrades

- Fully programmable from the front panel ASCII keyboard



Call Today for a free demonstration.



**Circuit Research Labs, Inc.**  
(602) 438-0888 (800) 535-7648  
FAX (602) 438-8227

# The Best Way to Hear from There

Only Zephyr™ gives you full-fidelity stereo on a single phone line.

No longer will your outside broadcasts be constrained by high cost and complicated equipment. Now all of your remotes can have near-CD quality sound. Using Integrated Services Digital Network (ISDN) telephone lines and the most advanced digital audio compression technology available, Telos makes setting up a remote as easy as sending a fax.

Zephyr is capable of transmitting broadcast quality audio virtually anywhere in the world for about the same price as an ordinary voice call.



It is the ideal solution for remote broadcasts, ad hoc networks, backup to microwave and satellite links, as well as many other applications.

To compress the program audio signal for transmission, Zephyr uses ISO/MPEG Layer III coding.

Several international listening tests have already demonstrated Layer III's superior performance at data rates of 64kbps or less per channel.

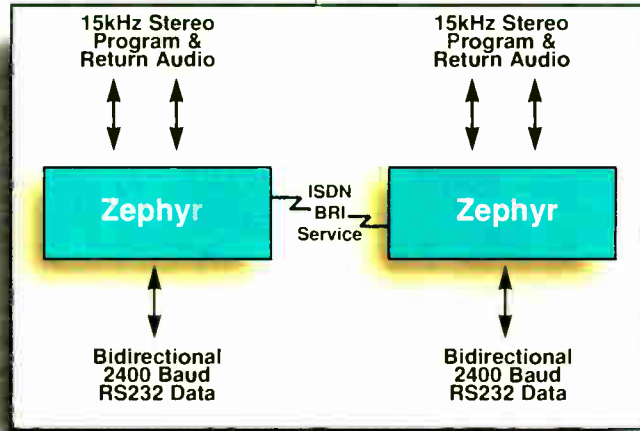

*only from*



2101 Superior Avenue  
Cleveland, Ohio 44114  
216.241.7225  
FAX: 216.241.4103

- Full duplex 15kHz stereo operation on one ISDN line or two Switched 56 lines using Layer III coding.
- Compatibility with older 7.5kHz codecs that use G.722.
- 2400 baud RS-232 bi-directional data for communications and control.
- Four "end-to-end" simple parallel contact closures for summary alarm and control of recorders and other devices.
- Split channel mode allows individual mono signals to be transmitted to separate sites.
- The ISDN terminal adapter is built-in and no separate boxes are needed.
- V.35/X.21 port allows Zephyr to be connected to one or two Switched 56 lines, spread spectrum wireless modems, satellite links, and other data paths.
- Designed for simple operation with full metering, analog audio limiting, and straightforward controls.
- Each unit can serve as either a transmitter or receiver.



**Telos Zephyr** DIGITAL NETWORK AUDIO TRANSMITTER

## ELECTRO-VOICE

### Electro-Voice Offers New Version of 635 Mic Featuring N/DYM Magnet Technology

**BUCHANAN, Mich.** For more than two decades, the Electro-Voice 635A has been used for electronic news gathering, field production and all manner of remotes. At NAB '94, EV introduced a new version of the 635—the 635N/D. The "N/D" designates the addition of EV's N/DYM magnet technology.

N/DYM magnets (neodymium iron boron) are far more powerful than traditional Alnico magnets. They increase the microphone's sensitivity 4 dB to a "hot" -51 dB. A refined resonator subtly improves high-frequency response with

retaining the original's classic sound.

EV is not discontinuing the 635A; instead the 635N/D joins the product line, providing ENG/EPF crews with another tool. Like the 635A, the 635N/D is available in the original fawn beige color as well as camera black.

The 635N/D offers several features that help assure the mic's durability. An acoustalloy diaphragm provides protection against the negative effects of salt air and severe mechanical shocks.

The diaphragm is also protected from dust and magnetic particles by a carefully designed integral windscreen and blast fil-

ter. The windscreen provides excellent protection from wind noise, excessive sibilance and vocal P-popping.

The 635N/D comes with the EV 311 stand adaptor, as well as 15 feet of two-conductor shielded broadcast-type cable with a three-pin XLR-type connector on the mic end.

For information, contact Jim Long in Michigan at 616-695-6831; fax: 616-695-1304; or circle Reader Service 31.



## WOHLER

### Rack-Mount Audio Monitor From Wohler Technology Assures Quality of Surround Sound Broadcasts

**SOUTH SAN FRANCISCO, Calif.** Increasing use of program materials encoded with surround sound channels has generated a need for basic confidence monitoring of surround audio at various points along the production and transmission signal chains.

Wohler Technologies developed the AMP-SUR, a rack-mount powered audio monitoring system specifically designed for surround sound programming. Housed in a magnetically shielded 2U chassis, the AMP-SUR incorporates a surround sound decoder, visual displays for levels and acoustic directional information and four powered loudspeakers.

Two side speakers provide continuous aural monitoring of the left and right channels (stereo program), while a center speaker may be switched between the center and surround channels. A fourth speaker provides non-directional bass reproduction below 500 Hz. Volume controls are provided for main left and right channels and the derived channels.

Line level inputs are accepted on XLR-F connectors, with parallel loop-through XLR-M outputs provided. The AMP-SUR is ideally suited for revealing potential problems in Dolby Surround-encoded materials because its decoding circuitry does not attempt to compensate for signal path problems such as inter-channel gain structure and phase shift.

As the popularity of surround sound programming expands in radio, the AMP-SUR is likely to find widespread applications in production rooms and on-air studios.

For information, contact Patrick Hayes in California at 415-589-5676; fax: 415-589-1355; or circle Reader Service 108.

## SHURE

### Portable Mic Mixer From Shure Specifically Designed for Remotes

**EVANSTON, Ill.** The Shure FP32A is a three-input, two-output portable microphone mixer specifically designed for remote audio recording, electronic field production, news gathering and location film production.

The FP32A features a dynamic range in excess of 100 dB, 48 V of phantom power, pop-up pan pots, headphone monitoring mode switch, internal DIP switches for 4,000 plus customized setups and more than 40 new features and improvements over the FP32.

The FP32A weighs just 1.6 kg and measures only 7.36 inches by 6.44 inches by 2.36 inches, making it truly portable.

For information, contact Shure in Illinois at 708-866-2200; fax: 708-866-2279; or circle Reader Service 160.

## RAMSA

### Ramsa/Panasonic Wireless Microphone System Fends Off Interference

**CYPRESS, Calif.** The true diversity wireless microphone system from Ramsa/Panasonic Pro Audio operates in the UHF TV band and is virtually unaffected by external noise and interference.

The 49 pre-programmed channels in the receiver and transmitter are ideal for maximum simultaneous multichannel operation. The system uses a phased lock loop (PLL) synthesizer system to monitor and adjust the carrier frequency, assuring that it remains within exacting tolerances.

The dynamic range of signals from the microphone is compressed by a 2:1 ratio before transmission. The signal is expanded by the receiver at a 1:2 ratio, returning all of the original dynamics. Transmitting compressed signals enhances reception stability, diminishes interference and expands the effective broadcast area.

The Ramsa wireless microphone system consists of the WX-RP110 and WX-RP158

hand-held wireless mics; WX-RP300 lavalier belt pack type transmitter; WX-RP810 true diversity single receiver (with an optional WX-RP800 wireless tuner unit); WX-RP820 UHF band true diversity receiver; WX-RP921 UHF band booster antenna (with wall mount bracket); and the SX-RP900 distributor.

For information, contact Ramsa/Panasonic in California at 714-373-7277; fax: 714-373-7903; or circle Reader Service 201.

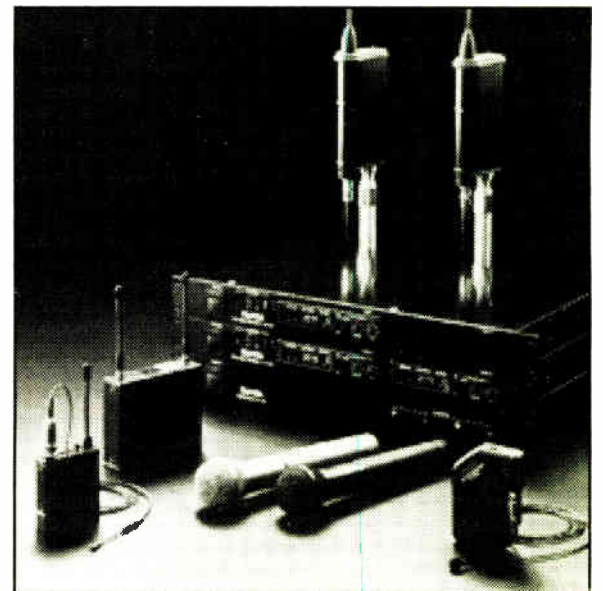

Don't Miss  
the June 30  
Deadline

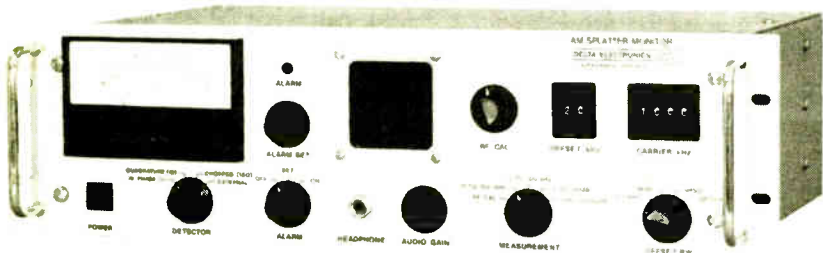

# Splatter Control.

The Delta Model SM-1 AM Splatter Monitor provides AM broadcast engineers with a means of accurately and easily measuring off-channel emissions to ensure compliance with the FCC regulations or the more stringent recommendations of the NRSC.

Manufactured in response to the NRSC (National Radio Systems Committee) for AM improvement, the SM-1 gives you the features you need to ensure compliance without buying an expensive spectrum analyzer.

The AM Splatter Monitor measures the level of splatter or any other spurious emissions which fall between 11 kHz and 100 kHz away from both sides of the carrier.

The AM Splatter Monitor is designed to be installed in an equipment rack and fed with an RF sample from the transmitter or common point. But, it's also portable so you can operate it from a twelve volt DC source, such as the cigarette lighter in your automobile. An RF sample is provided via an optional active antenna. This feature makes the Splatter Monitor ideal for investigating interference complaints.

The easy-to-operate SM-1 Splatter Monitor is the inexpensive way to verify FCC and NRSC compliance. Remember- the deadline is June 30.

**Limited quantity in stock now!**  
8:00 a.m. to 8:00 p.m. EST  
1-800-622-0022  
Fax 317-966-0623

**HARRIS  
ALLIED**

# Products & Services Showcase

For more information on the products shown below, circle the appropriate Reader Service No. (s) on the enclosed Subscription/Reader Service card or contact the advertiser directly.

## VACUUM CAPACITORS



Broadcast Capacitors for transmitters, couplers and phasers

- Variable or Fixed Capacitance
- Capacitance Ranges from 3 pF to 6600 pF
- Peak Test Voltages from 3 kV to 100 kV
- Current Ratings to 1000 Amperes
- Custom Designs Available on Request

**COMET  
NORTH AMERICA,  
INC.**

11 BELDEN AVE. • NORWALK • CT • 06850  
203-852-1231 • FAX: 203-838-3827

READER SERVICE NO. 204

## CONSOLE UPGRADE WITHOUT THE BIG EXPENSE



Approach digital quality with your yesteryear audio console by using BDI plug-in retrofit electronics. If the cost of a new console is depriving you of a competitive air sound then BDI electronics are the answer. Better headroom,

lower noise, lower distortion, dynamic range approaching 90dB and improved reliability are just some of the advantages of our easy to install upgrades. Call us today direct for a competitive air sound tomorrow!

*Our retrofit electronics currently support most:*

*Gates/Harris Consoles  
RCA Consoles  
McMartin Consoles  
McCurdy Consoles*

**bdi** Broadcast Devices, Inc.  
5 Crestview Avenue  
Peekskill, NY 10566 (914) 737-5032

READER SERVICE NO. 134

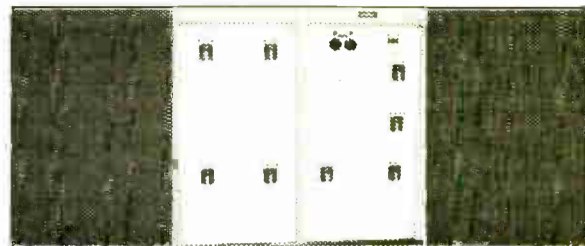

- CUSTOM ANTENNA PHASING SYSTEMS
- ANTENNA CONTROL SYSTEMS
- AM/MF ANTENNA TUNING UNITS
- DIPLEXERS & MULTIPLEXERS
- TRANSMITTER COMBINERS
- DUMMYLOADS (WITH MATCHING NETWORK)
- ASSOCIATED RF COMPONENTS
- CALL OR FAX FOR MORE INFORMATION

## PHASETEK INC.

550 CALIFORNIA RD. UNIT 11  
QUAKERTOWN, PA 18951

PHONE: 215-536-6648

FAX: 215-536-7180

READER SERVICE NO. 89



## Econco REBUILT POWER TUBES



Approximately One Half  
the Cost of New

3,000 Hour Unconditional Guarantee

Call for Our Price List

Econco 1318 Commerce Ave Woodland, CA 95695  
Phone: 916-662-7553 Fax: 916-666-7760 Telex: 176756  
Toll Free: 870-532-6626 From Canada: 800-848-8841

READER SERVICE NO. 148



## Excalibur Electronics

### CDA-1

Composite Distribution Amplifier



This 1 in, 3 out distribution amplifier allows you to distribute stereo composite and/or subcarrier signals as easily as audio.

- ◆ DC-100 kHz frequency response
- ◆ 90 dB signal/noise ratio
- ◆ +6 dB to -20 dB gain range
- ◆ Individual 20-turn output trimmers
- ◆ 1 3/4" rack mount enclosure

EXCALIBUR ELECTRONICS, INC., CHANTILLY, VIRGINIA

Please circle our bingo number for a data sheet and a dealer list.

READER SERVICE NO. 180

## Greetings... from the FCC

Get a friendly greeting from the FCC during your next inspection. Harold Hallikainen (author of Radio World's INSIGHT ON RULES) will inspect your station for compliance with the FCC's technical rules and prepare a report discussing areas that need attention. Chief operators, get an outside opinion confirming your excellent work! Station managers, get an outside opinion, just to make sure! A single low price includes the inspection, report, travel and lodging. A multi-station discount is available, so get together with your competitors!

This is a limited time offer, so call today!

**805-541-0200**

**Hallikainen & Friends, Inc.**

141 Suburban Road, San Luis Obispo, CA 93401-7590

fax +1-805-544-6715

email ap621@cleveland.freenet.edu

READER SERVICE NO. 135

## WE REPRESENT THE FINEST MANUFACTURERS OF BROADCAST AND RECORDING STUDIO EQUIPMENT

### AUDIO BROADCAST GROUP INC.

A new beginning for an  
Industry standard!  
Now with 3 sales offices to  
more efficiently provide all your  
broadcast equipment needs.

For additional information on how we can serve you, please call today

<b>MAIN SALES OFFICE</b> 2342 S. Division Avenue Grand Rapids Michigan 49507 Phone: 800-999-9281 Fax: 616-452-1652	<b>SOUTHEASTERN SALES OFFICE</b> 200 Fareway Drive, Suite 2 Smithfield, North Carolina 27577 Phone: 800-369-7623 Fax: 919-934-8120	<b>WESTERN SALES OFFICE</b> P.O. Box 1638 Palmdale, California 93550 Phone: 800-858-9008 Fax: 800-273-3321
--	--	--



For over 32 years

**AUDIO  
BROADCAST  
GROUP**

READER SERVICE NO. 177

World Radio History

## ARE YOU LOOKING FOR A COST EFFECTIVE ALTERNATIVE TO MANUFACTURER SERVICE?

### SERVICE, REPAIR & CALIBRATION

- ◆ STL's • RPU's • TSL's
- ◆ Exciters • AM/FM
- ◆ Broadcast Monitors •
- ◆ Remote Control Systems

### SPECIALIZING IN EQUIPMENT BY

- ◆ Beiar • Marti •
- ◆ Moseley • McMartin
- ◆ TFT • And others...

► An authorized  
TFT service center ◀

### IN CASE OF EMERGENCY

We can help get you back on the air with our STL Loaner Program. We have STL's available that will be set to your frequency prior to shipping. We also provide over-the-phone technical assistance.



2198 Hubbard Lane, Grants Pass, OR 97527

**(503) 471-2262**

READER SERVICE NO. 106

## DIGITAL DESIGNS

## Flexible Line of Digital Designs Monitors Suit A Variety of Purposes

**OKLAHOMA CITY** Digital Designs offers a flexible product line to meet the varied requirements of broadcast, project and personal studios. The monitor lines are designed to meet different sonic and budgetary requirements while incorporating the most features for dollar spent. Quality, accuracy and reliability standards are equally demanding for each product.

The upgraded Magma "a" series provides entry-level musician engineers an affordable speaker with specifications and performance rivaling speakers two and three times their price.

The upgraded DD "c" series is for mainstream studios that require high levels of precision and accuracy.

The DD181 is an ultra-high end two-way shielded monitor with a rubber-edge pure titanium dome tweeter and an 8-inch cast frame with carbon fiber/kevlar composite cone. Its unusually wide frequency range, 30 Hz to 20 kHz, makes it well-suited to reveal the many dimensions inherent in music.

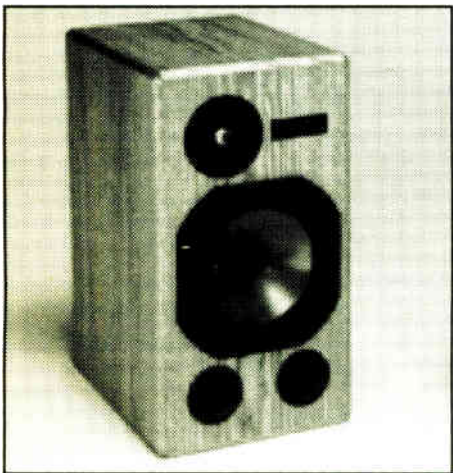

The "c" series and DD181 come with self-resetting solid state fuses to protect the tweeter and have beautiful hand-rubbed oak veneer cabinets. Switches on the crossover allow woofer and tweeter customization. All cabinets in the monitor line have dual ports and come with port plugs to customize bass response.

For information contact Alice Sandhu in Oklahoma at 405-946-4500; fax: 405-946-4544; or circle Reader Service 10.

## GALAXY

## Compact, Full-Range, High Fidelity Chameleon HF from Galaxy Audio

**WICHITA, Kan.** Galaxy Audio's Chameleon HF is a compact, full-range, hi-fidelity speaker. The 8-ohm duct ported reflex bass cabinet enclosure features a 5-inch poly paper woofer and a 1-inch ferrofluid cooled soft cloth dome tweeter, designed to accurately reproduce musical programs over a full range from 50 Hz to 20 kHz,  $\pm 6$  dB.

Built-in circuitry protects the tweeter from overloads and affords overall protection with an auto reset thermal breaker. With a powerful handling capacity of 40 W RMS/60 W peak and a sensitivity of 92 dB, the Chameleon HF is compatible with virtually all power amps.

It is available in both 70- and 100-V transformer versions with a choice of 10 W or 50 W maximum taps. The transformer models include six screw-driver adjustable taps, from 0.31 to 10 W, or 3.5 to 50 W as well as an "off" position. Push terminals serve as the input connection on all models.

The cabinet is constructed of rugged

black ABS, and features a cloth-covered Noryl grille. The Chameleon HF is also available in white or easily-painted primer gray finish, with custom colors available upon request. Other



options include a water resistant cone treatment that allows the speaker to be used outdoors, and a special swivel bracket for mounting the Chameleon HF on a wall, ceiling or mic stand.

For information, contact Gerald Graves in Kansas at 800-369-7768; fax: 316-263-0642; or circle Reader Service 71.

## LECTROSONICS

## Lectrosonics DC1 Adds Automatic Mixer Functions to Mic Monitors

**RIO RANCHO, N.M.** The micro-processor-controlled DC1 from Lectrosonics adds automatic mixer functions to any existing mixing console to reduce background noise and comb filtering caused by multiple open mics. An adaptive proportional gain algorithm allocates gain to the most active microphones and attenuates inactive microphones seamlessly, without hard switching.

Using the DC1 to follow microphone activity, the console operator is free to make adjustments other than simply chasing microphones. The level at each mic channel can be set at the beginning of the production, but the channel will be attenuated until there is activity at the microphone. The algorithm keeps track of which microphone has been on the loudest and longest and skews "priority" toward the most active microphone, keeping non-speech sounds at inactive

microphones from interfering.

The DC1 operates at unity gain, adding no noise or distortion to the console, to provide transparent operation. The operating parameters are programmable to accommodate different applications, user preferences and program material.

Three memory presets permit instant

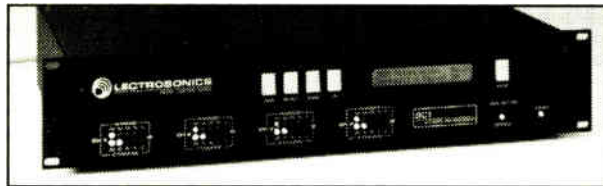

switching among operating parameters. A "soft" bypass is available from the front panel. When the unit is powered down, relays at each input provide a "hard" bypass.

The DC1 is covered by a one year limited warranty.

For information contact Bruce Jones in New Mexico at 800-821-1121; fax: 505-892-4501; or circle Reader Service 111.

## VEGA

## VegaNet Wireless System Expands Capabilities Of Wireless Microphones

**EL MONTE, Calif.** VegaNet equipment from Vega brings wireless microphone technology into the world of networking, graphical user interfaces and multimedia. Vega has adapted Lone Wolf's MediaLink networking technology to provide real time control and monitoring capabilities for wireless systems on an open architecture network.

The new system consists of at least one network enabled UHF receiver—the Vega R-662B—and a modular network interface equipment. When connected to the MediaLink network, it provides complete computer-based wireless monitoring and control capabilities for wireless applications of any size.

Vega's network interface hardware includes the model NE-8 mounting frame accommodating up to eight model NE-2 interface modules. The frame also includes an integral wide range 120/240 V power supply.

Each NE-2 module can interface two receivers, allowing as few as two and as many as 16 network-connected receivers per frame. Interchangeable Lone Wolf network I/O daughter cards are supported, allowing connection to several different network mediums, currently including glass fiber, plastic fiber and RS-232 cable.

Audio networking solves several problems, such as receiver location and performance degradation caused by RF cable loss or excessive reception ranges. It also opens up an array of useful new possibilities.

Fundamentally, networking allows you to locate wireless receivers virtually anywhere, solving the problem of lost RF performance. A small computer placed in the most convenient location allows the engineer to monitor and control wireless systems simply and easily.

For information, contact Robert Bell in California at 818-442-0782; fax: 818-444-1342; or circle Reader Service 142.

## CD Format Services....'90s Style!

Since 1991 we've offered music libraries & current hits on Ultrasonic-Q CD's. Our library of 6,000+ tracks has every flavor of A/C, Top-40, CHR, Country, Oldies and Classic Rock. We now have over 2000 clients worldwide!

If you deal with Broadcast Programming, TM Century or another service, call for our catalog and sample discs. See what you'll get and how little you'll pay with RPM. Complete format service starts at \$295.00 / month\*. Current & Recurrent hit update service is \$16.95/week or \$49.95/month.

Program your station 90's style. Get a high quality service at a fair rate. If you don't use CD's, you're missing a chance to make a big improvement in your sound. Our personal professional service will be a real pleasure too.

50 STATES & CANADA:

800-521-2537

\*Rates for markets of 50M population or less. surcharge for larger markets

Top Hits U.S.A. & Ultrasonic-Q Radio Disc trademarks of Radio Programming and Management, Inc., Orchard Lake, MI. Ultrasonic-Q system is Patented.

02-THE ONES YOU LOVE (EDIT) RICK ASTLEY -(412)-405/F/10-B  
03-WITHOUT YOU - MARIAH CAREY -(325)-318/F/6 -AP  
04-THE LADY IS A TRAMP  
FRANK SINATRA W/ LUTHER VANDROSS -(322)-320/C/7  
10-I'M IN THE MOOD (East 87th Mix) - CECE PENISTON -(400)-353/F/1 -A  
11-A DEEPER LOVE (C&C Hot Mix) - ARETHA FRANKLIN -(441)-439/C/0 -A  
12-ROCK & ROLL DREAMS COME TRUE (Radio) -MEATLOAF -(359)352/F/4-B  
13-(LAY YOUR HEAD ON MY) PILLOW - TONY TONI TONE -(435)-428/F/23-A  
14-MR JONES - COUNTING CROWS -(429)-427/C/5 -B  
15-DESIRE (EP VERSION) - EN VOGUE -(351)-344/F/2 -N

FORMAT - CUTS  
AC: 02 - 04  
CHR: 10 - 17  
COUNTRY: 20 - 25

ULTRASONIC-Q  
RADIO  
DISC  
FOR BROADCAST ONLY

COMPACT  
DISC  
DIGITAL AUDIO

16-RAINBOW MAN - GIOVANNI SALAH -(410)-403/F/40-B  
17-DIRTY DAWG - NKOTB F/ NICE AND SMOOTH -(412)-405/F/7 -B  
20-WHERE WAS I - RICKY VAN SHELTON -(306)-259/F/14-N  
21-TRYIN' TO GET OVER YOU - VINCE GILL -(343)-341/C/17-B  
22-LIFE #9 - MARTINA MC BRIDE -(359)-352/F/15-B  
23-(Who Says) YOU CAN'T HAVE IT ALL - ALAN JACKSON -(324)-321/C/8 -A  
24-IDA RED - ASLEEP AT THE WHEEL  
With/Jody Nix-Huey Lewis-Willie Nelson-Ran Benson  
(302)-300/C/17-A  
25-ALREADY GONE - TANYA TUCKER -(415)-408/F/14-A

TOP HITS U.S.A.

December 31, 1993

DISC ID: T204

rpm RADIO PROGRAMMING AND MANAGEMENT, INC.  
Since 1970  
4198 Orchard Lake Road  
Orchard Lake, MI 48323  
800-521-2537 MI: 810-681-2660

# Full function RDS for only \$1750



When you're ready for RDS, Modulation Sciences is ready for you. You already know us as the world's largest supplier of subcarrier equipment for radio and TV, with more Sidekick® SCA generators in use worldwide than all other brands combined.

Now we've made it easy and affordable for you to enjoy *all* the

benefits of broadcasting an RDS signal. Our RDS generator plugs right into your PC. And our included software gives you access to the entire CENELEC or U.S. RDS or RBDS Standard feature set.

So why buy an RDS coder offering only part of the RDS standard when, for even less money, you can have the whole thing?

*Modulation Sciences is a worldwide supplier of ModMinder® FM modulation monitors, StereoMaxx™ spatial image enlargers, composite audio processors and distribution amplifiers, Sidekick® subcarrier generators and receivers for FM and TV, Wired STL™ line drivers & receivers, TV stereo generators, SAP and PRO channel generators, and the remarkable new PROceiver™*

*For details on the RDS-1 System or any MSI product, contact your MSI dealer or*

**modulation sciences, inc.**

12 A World's Fair Drive • Somerset, NJ 08873 USA

Toll Free (800) 826-2603 • FAX (908) 302-0206 • Outside USA (908) 302-3090

# Products & Services Showcase

For more information on the products shown below, circle the appropriate Reader Service No. (s) on the enclosed Subscription/Reader Service card or contact the advertiser directly.



**Cellcast**  
REMOTE BROADCAST STUDIO

**THE CELLULAR DIFFERENCE**

- Easy to Use
- Reliable
- Cost Efficient
- Portable
- Flexible



Technology & convenience combine to bring you on-the-spot remote broadcast capabilities with excellent sound quality. Cellular transceiver, frequency extender, and mixer all in one! Powered by Ni-cad rechargeable batteries or AC power supply — utilizes cellular technology or land lines.

For more information call  
**1-800-852-1333**

**READER SERVICE NO. 156**

**HOT COUNTRY  
from HALLAND!**



**HOT OFF THE PRESS!** Our NEW 712-song CD library of the best Country hits on radio! On 34 compact discs... in spectacular digital stereo... perfect for today's contemporary country formats! Great selection, great audio, great price! Call Halland today for details.

**1-800-HALLAND**      Halland Broadcast      **818-963-6300**  
 (1-800-425-5263)      Services, Inc.      fax: 818-963-2070  
 1289 East Alosta Avenue, Glendora, CA 91740  
*Also available: CD libraries for Oldies, AC-Gold, & AC/CHR*

**READER SERVICE NO. 202**

**EQUIPMENT FINANCING**

**MARTIN LEASING CO.**

**FIXED RATE  
LONG TERMS**

- 1-Page Credit Application
- New or Used Equipment
- \$5,000-\$2,500,000
- 100% Financing—No Down Payment
- Conserves Bank Lines
- Under \$50,000—No Financials Required
- Nationwide Funding
- Refinancing Available
- Other Equipment, Too!

*QUICK RESPONSE 24-48 HOURS*

**BEN WEINGARTEN**

**1-800-253-2734 EXT. 22**

TEL: (310) 274-7988    FAX: (310) 274-1905

UPGRADES  
TRANSMITTERS  
ANTENNAS  
DIGITAL EQ.  
AUTOMATION  
STUDIO EQ.

**THE BROADCASTING EQUIPMENT SPECIALIST**

**READER SERVICE NO. 155**

**WHY PAY MORE  
FOR LESS?**

*PRISTINE INCLUDES EVERYTHING YOU NEED AT ONE LOW PRICE. INCLUDING REDUNDANT SYSTEMS!*

PRISTINE CD DIGITAL AUTOMATION SYSTEM including: 2 heavy duty 486/33/DX computers • 8+ hours of Dolby AC-2 stereo hard disk audio • music scheduling system • traffic system interface • digital editing package • 8 Pioneer TM-3 CD Players • CD audio mixer & amp • installation & training • leasing available



**\$18,995**

Distributed Nationally by  
**PROFESSIONAL MANAGEMENT SERVICES, INC.**  
803/370-2400 • FAX 803/370-2314  
INTERNATIONAL 310/670-7500 • FAX 310/670-0133

**READER SERVICE NO. 199**

**Updated bimonthly**

**Pike & Fischer's  
Broadcast Rules Service**

*Your best source for essential FCC compliance information*

Available in print or on Computer Disk

**P&F's Broadcast Rules Service includes:**

- Full text of FCC Rule Parts:
  - 73: Radio Broadcast Services
  - 74: Experimental, Auxiliary & Special Broadcast Services
  - 17: Antenna Construction, Marking & Lighting
  - 25: Satellite Communications
- Full text of FCC Notices of Proposed Rulemaking
- Exclusive, comprehensive bimonthly newsletter written by P&F's lawyer-editors
- FCC Forms & Instructions (print version only)

For further information, call today!  
**(301) 654-6262**

**Pike & Fischer, Inc.**  
Legal & Business Publishers since 1939  
4600 East-West Highway • Suite 200  
Bethesda, MD 20814  
Fax: (301) 654-6297

**READER SERVICE NO. 200**



**MICS**  
Music Inventory Control System

*Affordable - Low Price!*

**ONE TIME PURCHASE, NO MONTHLY FEES**

- Instant Recall of Song/Album Information
- Organize Your Entire Music Library
- Create a Complete Music Inventory
- Lookup Song, Artist, Group, etc.
- Print 30+ Different Reports
- Find a Song Instantly
- Create Playlists

**BRAND NEW!**

*The List Goes On....*

**What Is M I C S ?**

An affordable, user friendly program designed for all radio stations & private DJs. M I C S is tailored to give you instant information on your music. Provides printouts, hourly playlists, CD & album labels & much, much more. It's like having a staff of music directors at your fingertips!

**Call For FREE demo & Prices  
(800) 883-6615**

Music Inventory Control System  
P.O. Box 1280, Clyde, NC 28721

**READER SERVICE NO. 22**

**EVERYTHING YOU WILL EVER NEED**

- Eliminate flanging (hollow room) effect
- Eliminate bad room acoustics
- Hold absolute levels
- Correct voice symmetry

**AIRcorp 500PH  
Microphone Processor**



- Front panel input level select +4 to -50 dB
- Three section variable boost and cut equalization
- Compressor/Expander cross coupled for maximum punch
- Built-in earphone jack
- DE-ESSER designed to protect pre-emphasis curves
- Simultaneous mic level and line level outputs
- Internal 48 Vdc Phantom Supply

**AIR corp**

**Call your dealer**  
or call **214-255-0550**

**READER SERVICE NO. 42**

**Attention Advertisers!**

Reach 22,000 + Readers worldwide. RADIO WORLD's Product Showcase provides a perfect medium for test marketing your products and services. It's an efficient, effective and affordable advertising option.

For more information, including rates and deadlines, Fax your sales representative at

**1-703-998-2966**  
or call  
**1-800-336-3045**



**AUDIX**

**The Audix PowerHouse Series of Two-Way, Self-Amplified Monitors Suit Many Needs**

**TUALATIN, Ore.** The Audix PowerHouse (PH) series consists of five models of professional-level, self-amplified speakers delivering high-quality sound. Their small size and big, clean sound make the PH monitors great values for any general purpose listening, multimedia computer or professional studio applications.

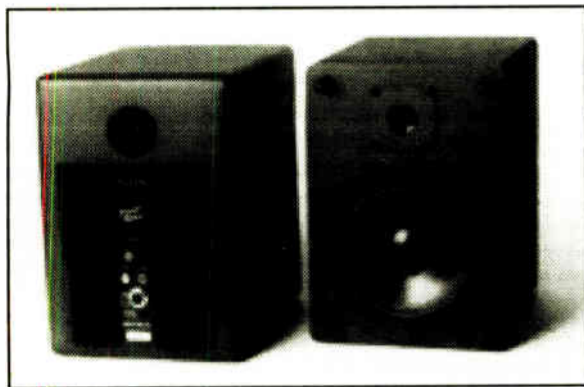

The PH3, PH5, PH6, PH15 and PH25 are two-way systems producing deep, rich studio-level sound with clean, tight bass and smooth accurate response. Typical features include 3-, 5- and 6-

inch and dual 5-inch long-excursion, rubber-surround woofers, single 0.75-inch ferrofluid tweeter, specially formulated composite or wood composite cabinets and gold connectors (PH15 and PH25). All models are available in magnetically shielded and unshielded versions.

The advanced PowerHouse amplifiers provide an extremely low distortion rate of 0.01 THD in mid-band to deliver the clean, well-defined sound demanded from professional audio equipment. At rated power, most other competitively priced brands have up to 200 to 300 times more distortion.

Audix also manufactures a complete line of exceptional quality passive monitors as well as professional vocal, instrument and studio recording microphones.

For information, contact Cliff Castle in Oregon at 503-692-4426; fax: 503-692-4658; or circle Reader Service 203.

**P.S.B.**

**P.S.B. Mic Windshield Designed to Handle Gale Force Winds**

**WEST HEIDELBERG, Australia** The GF-10 microphone wind shield from P.S.B. Engineering is made from ultra lightweight high-tensile steel and offers full protection of the valuable mics used in today's ENG/EFP work.

The GF-10 also features a shock-mount system made from durable, long-life rubber. The shock-mounts keep their shape and keep the mic in place. The shock-mount frame is designed to enable users to use Sennheiser MKH 416 size mics with foam wind covers fitted. A range of shock-mounts is available to suit most shotgun mics including: Sennheiser, AKG, beyerdynamic, Neumann and the Sony

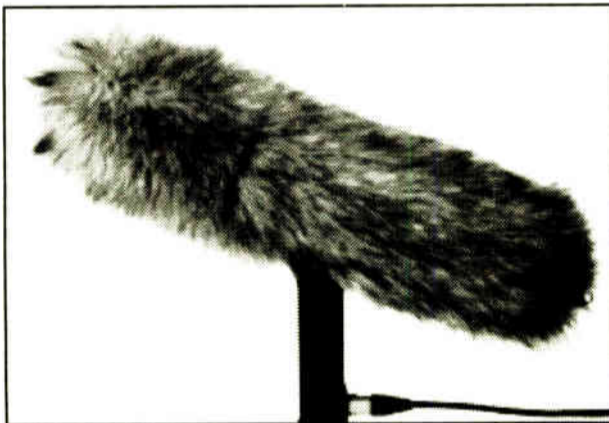

ECM MS5 stereo. The GF-10 also has the facility to house optional circuitry in its handle, e.g., a mic-line level preamp or a P-48 power supply module. The GF-10 is available to suit long- or short-type shotgun mics, is supplied standard with a Hi-wind cover, and a Lo-wind cover is available. For information, contact David Buchanan in Australia at 61-3-457-6044; fax: 61-3-459-2372; or circle Reader Service 144.

**SANKEN**

**Sanken CSS-5 Shotgun Microphone Loads Substantial Features into Small Package**

**WEST HOLLYWOOD, Calif.** The Sanken CSS-5 is a small, lightweight shotgun microphone with switchable mono/stereo functions. It was developed in conjunction with NHK (Japan National Radio) to record audio with precision directionality plus providing the option of capturing realistic stereophonic localization.

The standard 19-mm diameter permits use of a wide range of accessories developed for enhanced performance and field mobility. The CSS-5 provides three switchable modes to satisfy the various needs of location recording.

In the mono mode, sharp directivity is maintained over a wide frequency range

for the aimed frontal sound sources using the combination of a second gradient microphone and a line microphone.

In the normal mode, the CSS-5 clearly picks up aimed frontal sound and accurate stereo localization.

The wide mode is designed for stereo recording of sound effects where dialogue will be dubbed in at a later date. This mode allows a wider, 140-degree pickup, whereas conventional M-S microphones have a maximum of 127 degrees.

For information, contact Jim Schaller in California at 213-845-1155; fax: 213-845-1170; or circle Reader Service 183.

**AIR CORP**

**Pro-Announcer Mic Processor from Air Corp Controls Voice Levels Absolutely**

**IRVING, Texas** The AIR Corp Model 500 ph Pro-Announcer microphone processor controls voice levels absolutely.

Three equalizer sections with variable boost and cut are designed for easy adjustment without increasing room rumble or system hiss. A unique de-

level, servo-balanced to eliminate ground loops—can feed consoles, create external mix-minus sources or return to console patch points.

The compressor/expander is close coupled for maximum punch with no noise "rush up." The compressor protects for overshoots and holds average



esser suppresses excessive sibilance without being noticeable. The de-esser also protects FM pre-emphasis curves from sibilance overshoots. The 500 ph includes phase rotators to correct voice symmetry. And the result is a sound with more talk power and less compression.

Front panel selection of input levels in four ranges, from +4 dB to -50 dB, allows for easy integration into any system. Dual outputs—mic level and line

levels to within 3 dB of nominal output. The expander can easily reduce studio noise and room "ringing" with no apparent effect on the microphone sound.

It also comes standard with 48 VDC phantom power for condenser mics, and a front-panel headphone jack for ease of set up.

For information contact Jim Loupas in Texas at 214-255-0550; fax: 214-252-0020; or circle Reader Service 74.

**DEMETER**

**'Classic' Tube-Based Microphone Pre-Amplifier From Demeter**

**SANTA MONICA, Calif.** The Demeter VTMP2b microphone pre-amplifier is designed to provide natural accurate high fidelity sound reproduction. The two-channel unit is completely tube-based for a distinctively warm, yet clean and quiet sound.

The VTMP2b uses a classic tube design and the finest in modern components, including Jensen input transformers, polypropylene capacitors, metal film resistors, etc. The power supply features full regulation

of the B+ voltage (250 V) and the filament voltage (12.6 V) for low noise and quick response.

It also now features 60 dB of gain with a variable gain switch (40-50-60 dB), phase switchers, low cut filters, 20 dB mic pads, LED peak indicators, rotary faders, pin 2-3 selector switches and switchable 48 V phantom power.

Inputs are XLR and 1/4-inch phone plug; outputs are XLR, 1/4-inch and TT. Tubes are 2-12AX7a, 1-12AT7, 2-12BH7, all of which are readily available through standard sources and from the factory.

For information, contact Michael Meltzer in California at 818-986-7103; fax: 818-986-7103; or circle Reader Service 33.

**Basically excellent**

We improved the specs and simplified features until we knew we had created the best bulletproof, no-frills, high-performance FM exciter at the most competitive possible price. As with all BEXT excitors and our full line of RF equipment, the new LEX 25 is backed by our two year warranty and 24-hour customer service hotline.

- LEX 25
- 25 Watt FM Exciter
- S/N: >80dB
- THD: <0.03%
- \$1,995



1045 10th Ave.  
San Diego, CA 92101  
619-239-8462  
FAX: 619-239-8474



Circle (133) On Reader Service Card

**MICROTECH GEFELL**

**Miniature Cardioid Condenser Microphone From Microtech Gefell Features Trim Design**

**NEW YORK** Microtech Gefell introduced the new model M300 miniature cardioid condenser microphone. Featuring a trim, compact design, it is well suited for recording studios, broadcast facilities and sound reinforcement. It is an excellent choice for project studios needing an affordable mic for acoustic instruments.

The M300 capsule is unique in design, consisting of a ceramic chrome-plated back electrode and gold-sputtered membrane. The ampli-

fier, which is a transformerless hybrid design, is extremely quiet and provides excellent transient response.

Overall frequency response is very accurate with a smooth, gradual high frequency rise between 2 kHz and 15 kHz in the order of 2.5 dB. Off-axis response is uncolored and natural sounding.

The M300 requires standard 48 V phantom powering.

For information contact Jerry Graham at G Prime Ltd. in New York at 212-765-3415; fax: 212-581-8938; or circle Reader Service 68.

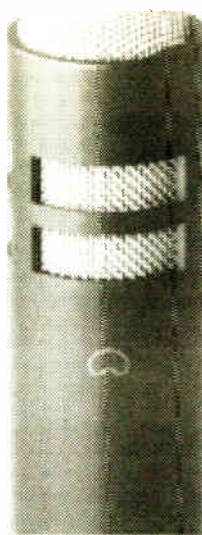

**CLEAR-COM**

**Matrix II Plus from Clear-Com Information Systems Appropriate for Many Applications**

**BERKELEY, Calif.** Many radio operations are upgrading old-style party-line intercom systems to modern, flexible systems like the Matrix Plus II by Clear-Com Intercom Systems. Matrix Plus II uses microprocessor technology to combine the best of point-to-point and party-line intercoms, letting users speak directly to other individuals or to entire groups with the push of a single button.

In addition to communicating between intercom stations, the system interfaces easily to IFB, telephone and two-way radio systems for easy communications between talent and crew in the studio and in the field. Expandable up to 100-by-100 ports, the Matrix Plus II can be instantly configured for almost any intercom application imaginable.

However, the relatively high price and large physical size of Matrix Plus II systems have limited their use to larger radio operations like WCBS-AM-FM in New York City and the Canadian Broadcasting Corp. in Montréal.

For smaller operations, Clear-Com offers the Mini-Matrix, a compact, cost-effective digital matrix intercom system. The Mini-Matrix supports all stations, interfaces and software features of the full-sized Matrix Plus II, and can be configured from two-by-two to 26-by-26 ports.

The system is fully programmable from an external PC using easy configuration software, and multiple system setups can be stored off-line for instant recall.

For information, contact Mike Goddard in California at 510-527-6666; fax: 510-527-6699; or circle Reader Service 83.

**KRK**

**Model 6000 Near-Field Monitors From KRK**

**HUNTINGTON BEACH, Calif.** The KRK Model 6000 is the latest close-field monitor to join the KRK line. Engineered along KRK's standard design parameters, the Model 6000 uses the latest in aerospace materials and the same high quality components found in KRK's more expensive models.

The Model 6000 monitors feature a 6-inch polyglass and a 1-inch kevlar drivers, and a frequency response of  $\pm 3$  dB from 62 Hz to 15 kHz. Nominal impedance is 8 ohms.

The cabinet measures 13 inches high by 9 inches wide by 10 inches deep and is the finish is custom gray texture.

For information, contact Craig Hill in California at 714-841-1600; fax: 714-375-6496; or circle Reader Service 65.

**D.W. FEARN**

**D.W. Fearn Amplifier Combines Modern Components with Tubes for 'Warmth'**

**POCOPSON, Pa.** The warmth and clarity of the classic tube mic preamps of the 1960s is recreated by the VT-1 professional vacuum tube microphone preamplifier from D.W. Fearn. Modern components and computer-optimized circuitry, unavailable during the vacuum tube era, elevate this design to a new level of performance.

The VT-1 gives sound recording studios and broadcasters a new tool to enhance the sound of their microphones. Clarity, presence and warmth are superior to solid state

microphone preamplifiers.

Over 100 audio professionals have evaluated the VT-1, along with other top-of-the-line vacuum tube and solid state mic preamps, and in numerous tests under controlled conditions have chosen the VT-1 as the best sounding preamp.

The VT-1 is a valuable addition to any studio's complement of outboard equipment.

For information, contact D.W. Fearn in Pennsylvania at 610-793-2526; fax: 610-793-1479; or circle Reader Service 27.

**8 TRACK  
DIGITAL EDITING  
BREAKS PRICE BARRIER  
\$5,495\***

- A digital audio editor designed for *Radio* production
- Learn to use in minutes, *much faster than tape*
- Cut, splice, move, and fade up to 4 stereo tracks
- Use Scrubbing to edit with your ears
- Use visual waveform editing to edit with your eyes
- An UNDO button enables you to go back and fix mistakes
- Digital Networking to transfer audio to your On Air machine
- Add Trak\*Star-8 software to a Digilink for only \$2,000

Trak\*Star-8 is the first cost effective multitrack digital audio editor designed for the radio broadcast professional. Fast and easy to use, produce your commercials on Trak\*Star and then transfer them in digital straight to the Digilink in your On Air studio. Dramatically reduce production time and save money !!!

For more information, call or write  
ARRAKIS,

**(303) 224-2248**

Consoles  
Modulux  
Trak\*Star  
Digilink  
Modulink

the premier broadcast manufacturer of consoles, furniture, Digilink and Trak\*Star digital audio products.

**ARRAKIS**

\* Suggested retail price. Complete system

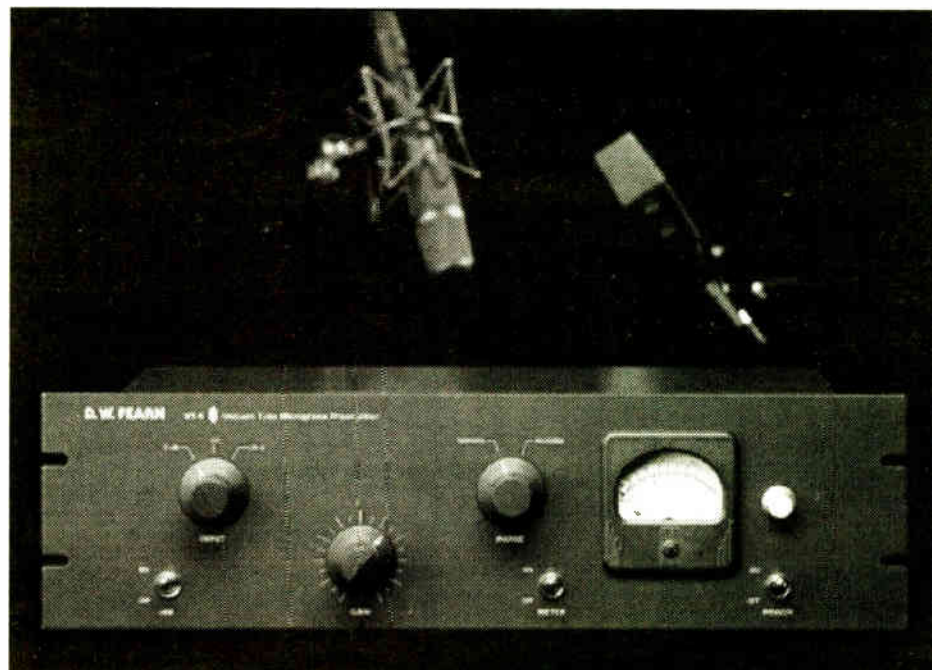
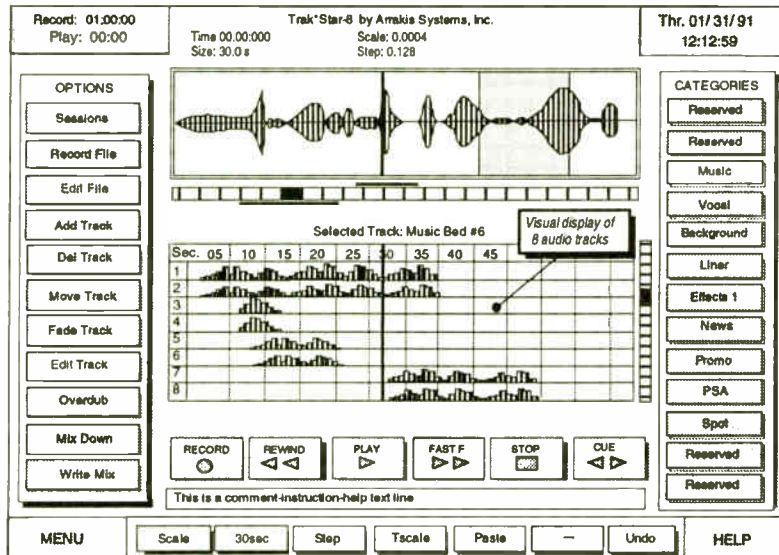

**BENCHMARK**

**Benchmark Media Systems MP-4 Family of Microphone Pre-Amps Are in Wide Use**

**SYRACUSE, N.Y.** Benchmark Media Systems Inc. manufactures the MP-4 family of microphone pre-amplifiers, which have become the standard for NPR's current rebuild, NBC Nightly News, WGBH(FM)'s rebuild of the Boston Symphony's broadcast facility and the Canadian Broadcasting Corp.'s new Toronto broadcast facility, among others.

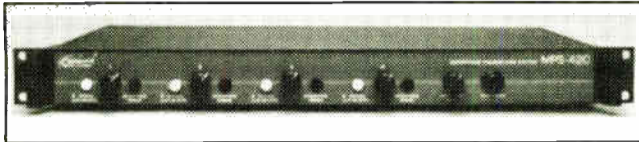

These broadcasters discovered in the MP-4 family exceptional RF immunity—better than transformer-coupled pre-amps—along with unparalleled sonic integrity. This sonic integrity is due to the total freedom from high frequency IMD. Unlike transformer-coupled devices, the MP-4 family pre-amps are also free from low frequency transformer THD. The 20 Hz to 20 kHz THD is 0.00088 percent (A = 40 dB).

MP-4 technology is available in several forms. MPS-400 and MPS-420s are stand-alone quad mic-pre systems in a 1 RU chassis. The MP-1 is a modular mic-pre; up to 12 units may be housed in a single 1 RU modular chassis with redun-

dant power. The 3 RU MDA-101 and MDA-102 system 1000 modules are single- and dual-channel mic-pre DAs with up to 100 outputs (MDA-101PA) from the 40-watt power amp output stage. A 96-module system of DA-101PAs is currently under construction for ESPN.

For information, contact Rory Rall, sales manager, in New York state at 800-262-4675 or 315-437-6300; fax: 315-437-8119; or circle Reader Service 29.

**People, Promotions and Appointments**

StandardNews appointed Mike Anthony director of news services for the company's full-service radio network and its full-service wire, ZapNews Wire.

LBA appointed Winfield Donat president. He is responsible of the day-to-day and long-term operations of the telecommunications consulting firm.

Wohler Technologies named Carl Dempsey as sales manager. He has primary responsibility for all sales through the company's dealer network in the U.S.

Former RW Editor Alex Zavistovich has formed Positive Spin Communications, a media relations and advertising consultancy, to provide a variety of creative services to broadcast-related businesses. For information contact Positive Spin Communications in Washington, D.C., at 202-544-6855.

Manhattan Production Music has moved. The new address is 355 West 52nd Street, 6th Floor, New York, NY 10019; phone: 212-333-5766; fax: 212-262-0814. The 1-800 number remains the same, 800-227-1954.

QMI was appointed the exclusive US distributor of the British-designed SoundField microphones.

beyerdynamic USA assumed distribution of Sound Performance Laboratory's (SPL) equalization processors.

Colfax Communications developed a field marketing department to serve its three Washington, D.C., radio stations: WBIG-FM, WGMS-FM and WTEM (AM).

McCurdy Radio Industries and Philip Drake Electronics have produced the formation of a committee to formulate a protocol for the interconnection of intelligent intercom communications systems.

Interested manufacturers or end users should contact Michael Guthrie in New Jersey at 201-891-5111.

CyberExpo '94, a biennial show intended for audio/visual dealers and contractors will be held September 21-22 in Strongsville, Ohio, just outside of Cleveland. It is sponsored by three Ohio-based manufacturers, and will feature exhibits by more than 40 leading manufacturers.

For information about CyberExpo '94, contact Bob Martin in Ohio at 216-238-1777.

**AURATONE**

**Two-Way Recording Monitor from Auratone Systems Appropriate for Many Applications**

**CORONADO, Calif.** The T66 compact two-way recording monitor from Auratone is a neutral close field console reference speaker, radio/television broadcast production monitor. It is an ideal sound distribution speaker due to little change in response over a 45-degree angle off-axis below 10 kHz.

The T66 uses two 6.5-inch woofers and a 1.25-inch dome tweeter.

Nominal impedance of the T66 is 8 ohms and nominal power is 100 W. Sensitivity is 90 dB and frequency response is 50 Hz to 18 kHz, ±2.5 dB. Crossover is 2.2 kHz.

It measures 12-inches high by 18-inches wide by 12.5-inches deep.

For information, contact Auratone Corp. in California at 619-297-2820; fax: 619-296-8734; or circle Reader Service 6.

**SPEAKERKITS**

**Studio Monitor Series from Speakerkits Provide Good Sound Reproduction**

**FLORAL PARK, N.Y.** The CD Loudspeakers studio monitor series from Speakerkits feature a new improved silk dome tweeter in both models 6.2 and 8.2. This 26-mm high frequency driver is capable of high power handling and extremely flat response from 2,500 to 30,000 Hz.

It features low damping ferrofluid, a linear response front plate, a damped cavity in the pole piece and a filed replaceable voice coil. It is crossed over at 18 dB per octave for maximum power handling and protection.

The CD studio monitors utilize magnesium cast frame bass drivers with mineral filled polycones and high dampening rubber surrounds. They are loaded into

high density ported enclosures finished in clear or black oak veneer.

These speakers have been designed to provide accurate sound reproduction, high power handling and long term service in studio or home environments.

The compact model CD 6.2 has a 6.5-inch bass driver and measures 15-inches high by 9-inches wide by 8-inches deep. It sells for \$395 per pair. The CD 8.3 has an 8-inch bass driver, measures 19-inches high by 12-inches wide by 11-inches deep and sells for \$495 per pair.

For information, contact Bob Wilson in New York state at 516-354-7006; fax: 516-354-7012; or circle Reader Service 125.

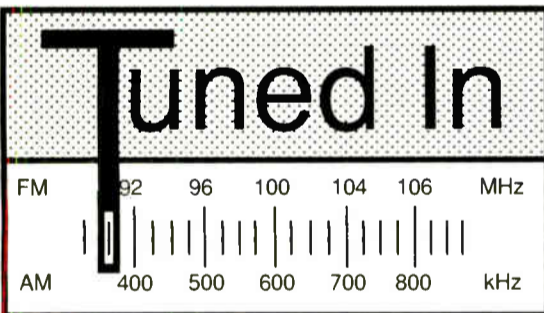

Broadcast Electronics hired two new regional sales managers for its digital products.

Criss Onan, based in Rochester, N.Y., handles the eastern region and can be reached at 716-223-3659 or fax: 716-223-1353. Susan Dingenthal, based in BE's Seattle office, handles the western region. She can be reached at 800-426-9082 or fax: 206-441-6582.

WEEV(AM) Announcer/Newscaster Jim Carr joined Nabet-CWA (AFL-CIO) New York (Local 16) as a volunteer advisor on disability affairs. Nabet-CWA-16 represents broadcast employees at ABC Radio-TV in New York.

**Company News**

Westwood One and Hooked On Phonics recently made an \$18,000 donation to the Amer-I-Can Foundation. Amer-I-Can works to help educate children at risk in communities with high incidence of street violence by providing programs that emphasize setting values and building self-esteem.

**TRUE BLUE FOR THE MORNING ZOO.**

**audiopak AA-4**

**Drive time is your busiest time, so make sure your spots, liners and music are on the cart more stations count on.**

**audiopak**  
BROADCAST CARTRIDGES

P.O. Box 3100 • Winchester VA 22601  
Tel: (800) 522-CART or (703) 667-8125  
Fax: (703) 667-6379

# MARKETPLACE

Recently Introduced Products for the Radio Broadcast Professional

## Updated Oscilloscope Display

Hewlett-Packard Co. introduced new versions of its digital HP 54600 series bench-top oscilloscope family with real time vector displays. Like analog oscilloscope displays, the enhanced displays on the HP 54600B series give test and measurement engineers waveform slew-rate information at a glance, allowing quick and effective troubleshooting of circuits.

The HP 54600B series represent more slowly changing waveforms and dimmer traces representing more rapidly changing waveforms.

For information, contact Hewlett-Packard in California at 800-452-4844, ext. 8278; or circle **Reader Service 23**.

## Permanent ID Marker

Jensen tools offers an electrochemical marking system that uses a low voltage, low amperage electrical current to etch permanent identification marks on metal. It is a safe, simple and economical way to mark metal products.

The IMG Electromark SS111 works by means of a 115 VAC, 50/60 Hz power supply, stenciling tool, electrolyte and neutralizer (all supplied). The electrolyte, when applied to the stencil, allows the current to pass through and onto the metal: The

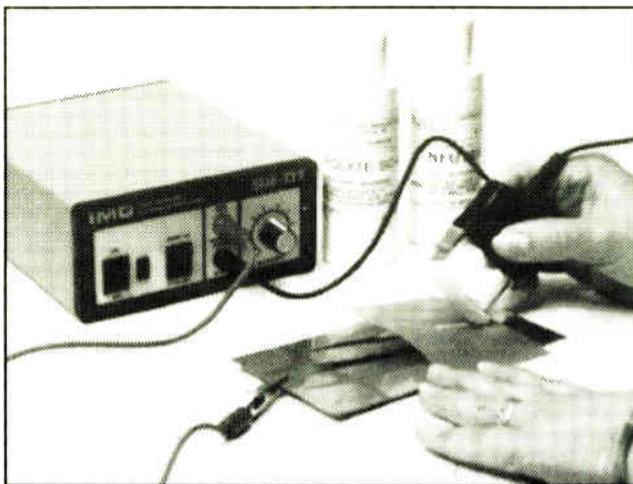

mark is permanent.

For information, contact Jensen Tools at 800-426-1194; fax: 602-438-1690; or circle **Reader Service 55**.

## Noise and Fire Control

illbruck Inc., a leading manufacturer of acoustical and noise control treatments, provides Sonex 1 as a flame-resistant alternative for noise reduction and acoustic control.

The contour of Sonex 1 is based upon an anechoic wedge design, which carries noise to the lowest point on the surface, where it is trapped and deflected. It is created from a light porous, fiber-free melamine foam that meets all Class 1 building requirements for flame spread, smoke density and fuel consumption.

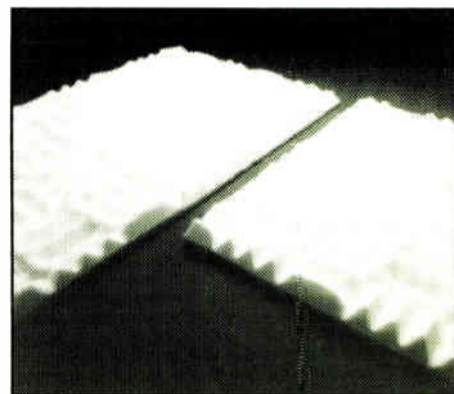

Sonex 1 can withstand constant temperatures up to 302 degrees Fahrenheit and intermittent, short-term temperatures of 482 degrees Fahrenheit. With the optional Hypalon coating, Sonex 1 repels oil, acid and solvents.

For information contact illbruck Inc. in Minnesota at 800-662-0032; or circle **Reader Service 69**.

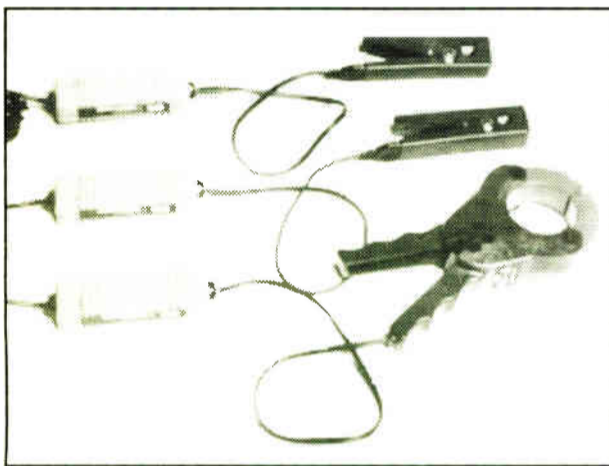

## Clamp-On SmartProbes

All BMI SmartProbe current transducers provide high accuracy measurements with patented built-in descriptor modules that remember and correct for the gain and offset of each probe.

In addition, when used for harmonics analysis with the BMI PowerProfiler, each SmartProbe provides information on how it measures phase shift and harmonic amplitude, making PowerProfiler harmonics current measurements extremely accurate.

The new clamp-on CTs include the A-705 5-amp SmartProbe for measuring current on the secondary of a transformer, the A-721 20-amp SmartProbe for measuring low currents and the A-732 300-amp SmartProbe for measuring current at the panel.

SmartProbes, now 10 in all, work with the BMI 8800 PowerScope and 3030/3060/3030A PowerProfiler power analyzers.

For information, contact BMI in California at 408-970-3700; fax: 408-970-3720; or circle **Reader Service 96**.

## Distribution Amp

The Model 8400 distribution amplifier from Audioarts Engineering provides digital quality audio performance in a single rack unit of space. It can be user-configured for a single stereo input by eight stereo outputs; two one stereo input by four stereo outputs; a single mono input by 16 mono outputs; two one mono input by eight mono outputs; or four one mono inputs by four mono outputs.

The Model 8400 features heavy duty, rear-panel Molex three-pin connectors for each I/O channel. All I/Os are electronically balanced.

The design of the Model 8400 is very straight forward, and the front panel features multiturn trims for easy adjustment. The unit's dynamic range is 121 dB, with frequency response from 20 Hz to 20 kHz at +0, -0.1 dB.

For information, contact Mike Shane in New York state at 315-452-5000; fax: 315-452-0160; or circle **Reader Service 97**.



## Flexible Digital Audio Workstation

The PostPro SD digital audio workstation from The Synclavier Company adapts to your working style. It can operate like a conventional multitrack, a totally non-

destructive random access editor or as an intuitive graphical tape-style editor. It even includes a sequencer style editing interface that integrates RAM, disk and MIDI controller.

The PostPro SD is both modular and expandable. It starts with four tracks and can be expanded to up to 16 tracks. The high-speed FastTrax 2.4 gigabyte removable drive system assures virtually unlimited recording time, just like tape.

Options include: the SAC-70 card with high quality time compression and sample rate conversion algorithms; CMX Autoconform software for loading and conforming source material; or the Synclavier sound design module with up to 32 voices and 256MB of sample RAM.

For information, contact Mark Kaltman in New Hampshire at 603-448-8887; fax: 603-448-6350; or circle **Reader Service 162**.

## Full-Feature Transmitter/Exciter

Itelco offers its T242 solid state 250 W FM transmitter/exciter. Based upon the same frame as other Itelco transmitters, the T242 is designed to offer the ultimate in FM performance.

It is user-adjustable from 80 to 250 W, output power. Typical performance characteristics include 92 dB SNR; 65 dB stereo separation; 0.03 THD + N distortion; -105 dBc spurious emission; and 75 dB AM noise.

The T242 includes plug-in AF input, RF modulator, RF amplifier and RF power amp modules, and optional stereo coder and RDS/RBDS plug-in modules.

For information, contact Claude-Eve Rosenfeld in Italy at 39-763-316-265; fax: 39-763-316-239; or circle **Reader Service 47**.

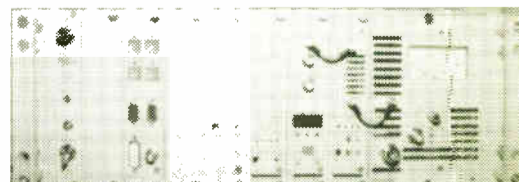

## SUBSCRIPTION/READER SERVICE FORM

**Radio World**  
FREE Subscription/Renewal Card

I would like to receive or continue receiving **Radio World**

FREE each month.  Yes  No

Signature \_\_\_\_\_ Date \_\_\_\_\_

Please print and include all information:

Name \_\_\_\_\_ Title \_\_\_\_\_

Company/Station \_\_\_\_\_

Address \_\_\_\_\_

City \_\_\_\_\_ State \_\_\_\_\_ ZIP \_\_\_\_\_

Business Telephone ( ) \_\_\_\_\_

Please circle only one entry for each category:

### I. Type of Firm

- |                              |                                 |
|------------------------------|---------------------------------|
| D. Combination AM/FM station | F. Recording Studio             |
| A. Commercial AM station     | G. TV station/teleprod facility |
| B. Commercial FM station     | H. Consultant/ind engineer      |
| C. Educational FM station    | I. Mfg. distributor or dealer   |
| E. Network/group owner       | J. Other _____                  |

### II. Job Function

- |                           |                          |
|---------------------------|--------------------------|
| A. Ownership              | G. Sales manager         |
| B. General management     | E. News operations       |
| C. Engineering            | F. Other (specify) _____ |
| D. Programming/production |                          |

### Reader Service

May 18, 1994 Use until August 18, 1994

Please first fill out contact information at left. Then check each advertisement for corresponding number and circle below.

#### Purchasing Authority

1. Recommend 2. Specify 3. Approve

001	023	045	067	089	111	133	155	177	199
002	024	046	068	090	112	134	156	178	200
003	025	047	069	091	113	135	157	179	201
004	026	048	070	092	114	136	158	180	202
005	027	049	071	093	115	137	159	181	203
006	028	050	072	094	116	138	160	182	204
007	029	051	073	095	117	139	161	183	205
008	030	052	074	096	118	140	162	184	206
009	031	053	075	097	119	141	163	185	207
010	032	054	076	098	120	142	164	186	208
011	033	055	077	099	121	143	165	187	209
012	034	056	078	100	122	144	166	188	210
013	035	057	079	101	123	145	167	189	211
014	036	058	080	102	124	146	168	190	212
015	037	059	081	103	125	147	169	191	213
016	038	060	082	104	126	148	170	192	214
017	039	061	083	105	127	149	171	193	215
018	040	062	084	106	128	150	172	194	216
019	041	063	085	107	129	151	173	195	217
020	042	064	086	108	130	152	174	196	218
021	043	065	087	109	131	153	175	197	219
022	044	066	088	110	132	154	176	198	220

Copy & Mail to: Radio World, PO Box 1214, Falls Church, VA 22041, or FAX to: 703-998-2966

# RadioWorld

# Broadcast Equipment Exchange

"Broadcast Equipment Exchange" accepts no responsibility for the condition of the equipment listed or for the specifics of transactions made between buyers and sellers.

## ACOUSTICS

### Want To Sell

**STUDIOFOAM**  
SOUND ABSORBENT WEDGES  
TESTS UP TO 40% BETTER THAN SONEX  
COSTS LESS - BETTER COLORS - BETTER CUT

**SONOMATT**  
4'x8'x2" Sheets \$29.99 Ea. In Pairs \$49.99  
VENUS 12" x 4" NRC 1.30 Flat 10K-125Hz  
THAT THEY REALLY KICK IN (125Hz NRC)  
BASS TRAPS 1' x 3' Charcoal Gray 2 For Just \$150!  
USA Form Box 2009 Indianapolis IN 46220 (317) 251-2982

**1-800-95-WEDGE**

Circle (63) On Reader Service Card

## AMPLIFIERS

### Want To Sell

SAE impulse noise reduction amp (scratch filter) stereo, \$75; SMC SPA-10 20 W stereo line amp, \$50. P Bridger KGKO, 202 E Cross, Benton AR 72015. 501-778-8257.

McIntosh MC-75 tube power amp, gd cond, orig electronics, KT-88 tubes, \$700; McIntosh C-11 tubed stereo pre-amp, near mint, \$525. R Links, Links Sound, 1656 California St, Berkeley CA 94703. 510-845-5557 eve.

Dynaco stereo 120 solid state, rack mt \$229, Dynaco stereo 70 tube amp all new tubes! Dynaco PAT 4 preamps \$59. W Gunn 619-320-0728.

New 12 kW FM amp under \$24,000. Call for details. Bill Hoffman, 518-743-1601.

### Want To Buy

Marantz Model 1, audio console pre-amp, single or pair, and Model 6 stereo adapter. P Chance, Imperial Analog, 925 Clinton Street, Philadelphia PA 19107. 215-574-8147.

Western Electric pwr amp wrking or not & output transformers for same. RQ Studio, Larson Rd #4, N Reading MA 01864. 508-664-0174.

## ANTENNAS/TOWERS/CABLES

### Want To Sell

Harris/ERI, 3 bay, low power, \$3000. T Beschta, WAQE, POB 703, Rice Lake WI 54868. 715-234-9059.

Jampro 6 bay, w/radomes, 99.1 MHz. K Stone, KUTZ FM, 12710 Research Blvd #380, Austin TX 78759. 512-331-9191.

Shively 6813, 2 bay w/radomes, rebuilt and in factory boxes, 95.4 MHz, \$2400. B Bailey, WHYR, POB 567, Saco ME 04072. 207-284-9600.

157' tower R-25, still in air, you take down, great cond. J Kesler, WOBZ, POB 446, Livingston KY 40445. 606-843-22A 9999.

## FM - ANTENNAS

Designed and built for your frequency. Choose from 1 to 12 bays and five power levels. Financing available. Call Jimmie Joynt at S.W.R. 214-335-3425

Phelps-Dodge 3 bay FM, on 107.1, avail now, B/O, will trade. D Sports, WCLA-FM, POB 427, Clayton GA 30417. 912-739-3035.

200' 6" hard line, 20' sections, connectors & elbows, FM or TV, call for prices. K Crosthwait, WTNN, 13206 Buttermilk Rd, Knoxville TN 37932. 615-690-8807.

**TOWER LIGHTING CONTROLS**  
For Aviation Obstruction Lights, Beacons, and Strobe Light Systems.



Photoelectric controls that conform to FAA requirements. Some models are also available on a custom basis.

## J PRECISION

PRECISION MULTIPLE CONTROLS, INC  
33 Greenwood Ave. • Madison NJ 07432  
Tel (201) 444-0600 • Fax (201) 445-0675

Andrew 75R coax line coupler, 7/8" flange (2), \$50 ea; Andrew 1860 reducer 1 5/8" to 7/8" (2), \$75 ea. K Crosthwait, WTNN, 13206 Buttermilk Rd, Knoxville TN 37932. 615-690-8807.

Andrew transmission line air compressor, 3.8 lbs/sq in, \$425. R Chambers, 3015 Johnstonville Rd, Susanville CA 96130. 916-257-2121.

Cablewave transmission line, 650' of used 3" line. Type HCC300-50. Connectors installed (one damaged during removal). Installed on wooden reel. Sold as complete unit for \$5200 (firm). You pay shipping costs. G. Calhoun, Sioux City, Iowa. 712-239-3920.

Shively 6813, 2 bay w/radomes, rebuilt and in factory boxes, 95.4 MHz, \$2400. B Bailey, WHYR, POB 567, Saco ME 04072. 207-284-9600.

Andrew 1-5/8" coax, JH7-50A, 310' (several), \$7.25/ft., any length. Jim Musseli, 1421 Bay Ave., Santa Maria, CA 93454. (805) 922-7775.

### Want To Buy

Stand by antennas on 104.3, 95.7 and 99.7. B Lacy, KEMA FM, 3611 Soncy 6A, Amarillo TX 79121. 806-355-4554.

RF connector, BNC or Type N to 1 5/8 EIA flange. B Campbell, KRIG, 918-333-7943.

Rohn 45 tower, want 14 sections in gd cond; 3 or 6 bay CP FM antenna to handle 3 kW input at 99.5 MHz; 1 5/8" flange connectors to fit Andrew foam cable (2). K Diebel, KTJC FM, Rayville LA 71269. 318-728-5852.

FM antenna 5 or 6 bay tuned to 95.1 or 95.3 MHz, prefer ERI or Jampro; 340' and 540' tower in gd cond. L Fuss, WDTL-FM, POB 1438, Cleveland MS 38732. 601-846-0927.

## AUDIO PRODUCTION

### Want To Sell

Teac AN-300, Dolby, 4 chnl, noise reduction, \$45, MXR (dbx type II) \$35; dbx 124 (type II) noise reduction, 4 chnl, \$45. G Dunn, 5383 Willow Lake Ct, Byron CA 94514. 510-516-0299.

UREI 539 1/3 oct EQ (4), \$300 ea; UREI 525 crossover (4), \$325 ea; Crown MX-4 crossovers (4), \$195. R McMillen, Super Duper Audio Duplicating, 1634 SW Alder St, Portland OR 97205.

Used audio equip; consoles, carts, reels, processing, call for list. B Weiss, KMXV/KUDL, 3101 Broadway Suite 460, Kansas City MO 64111. 816-753-0933.

Sennheiser wireless infrared stereo headphones & xmtr, little use, work great, \$150; dbx 4BX dynamic range expander, \$250. DigiDesign ProTools 8 track comp system, little use, new software, \$8500. R McMillen, Super Duper Audio Duplicating, 1634 SW Alder St, Portland OR 97205.

**SAVE \$300 ON IT**

**96 & 144 POINT PATCH BAYS**  
brokers of line and coarse used equipment  
**audio village 619/320-0728**

Eventide BD955, digital delay, \$875. B Hill, KALK, 106 S Jefferson Ave, Mt Pleasant TX 75455. 903-577-9770.

Yamaha SPX 90 effects processor, \$500. T Lewczyk, WLTV FM, 7 Parkway Ctr #780, Pittsburgh PA 15220. 412-922-9290.

**Looking for Audio Bargains?**

**We BUY \* SELL \* TRADE**  
**QUALITY USED EQUIPMENT**  
**317-962-8596**

**HARRIS ALLIED**

SAE 5000 Click and Pop remover, mint, \$125. R Links, Links Sound, 1656 California St, Berkeley CA 94703. 510-845-5557 evenings.

Demeter 4 channel rack mount tube direct box NEW \$795. W Gunn 619-320-0728.

ADC 96 & 144 Pr TT patchbays, excellent condition, 1 rack space, 3 rows of 48, top 2 rows normalled, \$149, 96 is 2 row normalled, \$129 (you remove old wiring) or we totally refurbish with new front panel, ready to install, \$199-229. TT cords up to 10 per bay at \$9 ea, reg \$13.95, also 1/4" bays. Audio Village, 619-320-0728, or Fax 619-320-2454.

Gentner GT300 teleconference unit, new in box, \$750; Shure AMS 4000 new, no manual, \$900; Dyaxis I, system sync, DSP card, 320 HD, Mac Portrait display & Mac II driver card, very good condition, \$2750 plus shipping. Klay 801-272-1814.

### Want To Buy

UREI-1176 LN, Inovonics Map II, Autogram/Collins K-10A or K-6A console, need immediately. G Goldsmith, POB 5786, Beverly Hills CA 90209. 310-696-0177.

Smartcaster, latest software, 7 day walk away, 5 hr rec time, excellent condition, \$2500. J Schloss, KICD-AM/FM, 2600 N Hiway Blvd, Spencer IA 51301. 712-262-1240.

Formet Sentry System complete w/never used DS1-700 hard drive, Pioneer 6-pack CD players (32), less than 2 years old, \$18,000. D McKay, KXTZ, 307 Water St, Henderson NV 89015. 702-564-6066.

BE Control 16 brains with audio switchers (2), Otari ARS 1000 R-R in excellent condition (5); working SMC Sonomag Carousels (2); SMC Sonomag Carousels good for parts (3); ITC triple stacker cart machine with R/PB; ITC triple stacker with PB only, cabinets included. M Jones, WZKB, POB 520, Wallace NC 28466. 910-285-4900.

SMC MSP-1 automation system, 1984 model including 2-450 bi-directional Carousels, 721 dual play cart drawer, remote head & power supply in SMC rack with all manuals, \$1995/BO. B Christie, Grande Radio Group, POB 907, La Grande OR 97850. 503-963-4121.

Cetec 7000 II, with Go-Cart 78 (4), Go-Cart 24 (2), Otari ARS-1000 (2), Instacarts with interface (2), all mounted in racks, Best Offer. M Stockwell, KEZR, POB 2337, San Jose CA 95109.

Otari ARS-1000 (5), Carousels (3), SMC 712 dual cart player, IGM go cart 24 (2), BO all or part. R Wynne, KFLS/KKRB, POB 1450, Klamath Falls OR 97601. 503-882-4656.

Cetec 7000 programm automation system, 5046 event memory, terminal, racks, source cards, 350 series Carousels (4), 250 series Carousels (3), Audiofile (2), ITC 760 R-R (2), PB decks, more with spares & extra cards, \$2500 for all or will sell separately. E Moody, KJEM/KESE, 216 N Main St, Bentonville AR 72712. 501-273-9039.

Control Design 25 Hz tone detector, \$150. P Bridger, KGKO, 202 E Cross, Benton AR 72015. 501-778-8257.

360 Systems Digidart hard disk audio storage system, handles 3 1/4 hrs in stereo, \$4000. L Fuss, WDTL-FM, POB 1438, Cleveland MS 38732. 601-846-0927.

## MERCENARY AUDIO

### WANTS TO BUY YOUR:

NEVE-SSL-TRIDENT-AMEK  
UREI-TELETRONIX-FAIRCHILD  
PULTEC-LANG-LEXICON  
UNIVERSAL AUDIO-NEUMANN  
AKG-TELEFUNKEN-AMS

**ANYTHING THAT IS OF EXCEPTIONAL AUDIO QUALITY!**

**TOP DOLLAR PAID**

"this is not a problem"  
**(508)543-0069 TEL**  
**(508)543-9670 FAX**

Fairchild 600 conac or 602 Conex high frequency limiters. J Gangwer, 942 32nd St, Richmond CA 94804. 415-644-2363.

04A 105B TM Century Ultimate Digital Studio, CD jukebox controller w/7 Pioneer 18-disk CD players, \$6000; TM Century Gold Disk library for country format, B/O. L Fuss, WDTL-FM, POB 1438, Cleveland MS 38732. 601-846-0927.

## AUTOMATION EQUIPMENT

### Want To Sell

Audiofile II, single column, 10 slots, 3 Audiofile I, various shape, 903 boards. B Bailey, WHYR, POB 567, Saco ME 04072. 207-284-9600.

Audiofile II, single column, 10 slots, 3 Audiofile I, various shape, 903 boards. B Bailey, WHYR, POB 567, Saco ME 04072. 207-284-9600.

## HE HALL Electronics

1305-F Seminole Trail Charlottesville VA 22901

Here are just some of the bargains we have in stock:

FTC 3D Mono Cart Player -	Rebuilt	\$ 1,295
Fidelpak CTR-12 Stereo Play Cart Machine -	Rebuilt	\$ 895
Harris CC-II Mono RP Cart Machine - Closeout -	Rebuilt	\$ 395
Revox PR-99 Reel Player w/ 25Hz Sensor -	AS NEW	\$ 495
ATI Stereo BC8SR 8 Pot Console - (List \$ 3,595)	Rebuilt	\$ 995
Ramko DC-SRA 5 Pot Rack Mount Mono Mixer -	Rebuilt	\$ 245
Eventide H-3000B Harmonizer - (1 only)	NEW	\$ 1,995
Telos 10 Digital Hybrid -	Rebuilt	\$ 895
TRC-15-AW 15 Ch. Remote Control -	Rebuilt	\$ 695
Marti MW-500 Microwave Booster Amp -	Rebuilt	\$ 1,295
Belar FMS-1 (only) Stereo Mod. Monitor -	Rebuilt	\$ 795
LPB RC-25B Tube-Type 20 Watt AM Transmitter -	Rebuilt	\$ 295
CRI 'DYNAFEX' DX-2 Stereo Noise Reduction -	Rebuilt	\$ 259
Samban SAWS-22GTR Guitar Rack Wireless Mic -	NEW	\$ 298
Orban RET-27 Kit. Updates 8100A to 8100A/I -	NEW	\$ 75
Microtrak 303 12" Tone Arms -	NEW	\$ 99



## SINE SYSTEMS

### Announcing New Crisp Voice

The RFC-2 provides transmitter power control, has alarm dial out for 6 numbers, and provides up to 64 channels of control and metering.



The DAI-1 easily handles EBS requirements for "walk away" operations. It also allows direct access to the air chain in addition to providing remote broadcasts. The best & lowest cost 'dial-up' remote control available.

### Spring Specials:

SP8 Heavy Duty Surge Protector \$ 99  
SU-5 Voice/Software Upgrade \$ 159

**Complete system under \$ 1300**

## SM-1 AM Splatter Monitor



**Beat July 1st Deadline!**  
**NRSC-2 Monitoring Requirement.**

- Contract Engineers - Additional Income Opportunity
- Inexpensive means of verifying FCC compliance
- Easy to operate and interpret measured results
- 450 KHz to 1800 KHz phase-locked operation
- Portable operation from 12 VDC supply
- Alarm output permits remote control monitoring

DELTA ELECTRONICS



Call us for the Best New & Completely Rebuilt Equipment! (804) 974-6466

Fax: (804) 974-6450

**AUTOMATION EQUIPMENT...WTS**

**Cetec/Shafar 7000** w/10 Audiofiles (2), IGM stereo Instacart, Wegener satellite receivers (2), all or part, BO. KAZZ FM, POB 1369, Deer Park WA 99006. 509-276-8816.

**Harris 9001** incl brain, switcher, power supply, TEC-70 terminal and keyboard, manuals, also second system for back-up, BO. R Wynne, KFLS/KKRB, POB 1450, Klamath Falls OR 97601. 503-882-4656.

**Sparta 25 Hz** tone generator & filter, \$200. P Bridger, KGKO, 202 E Cross, Benton AR 72015. 501-778-8257.

**BE Control 16** inc IGM Go-Carts (7), Otari reels (2), excellent condition, priced to sell. M Young, WJON, POB 220, St Cloud MN 56302. 612-251-4422.

**SMC DP-2** stereo automation system, 3 R-R, 2 Carousels, \$3500. P Bridger, KGKO, 202 E Cross, Benton AR 72015. 501-778-8257.

**CART MACHINES**

**Want To Sell**

**SMC 590**, cart recorder in good condition, mono R/P, newer style head gasket with many spare parts, \$150. B Bailey, WHYR, POB 567, Saco ME 04072. 207-284-9600.

**BE 5300C** tripledeck, stereo, PB, mint less than 50 hours, BO. R Kaufman, Pams Productions, POB 462247, Garland TX 75046. 214-271-7625, after 3PM CDT.

Great Prices on original equipment tape heads for ITC, BE, Fidelipac, Otari, Tascam & others!

**HE Hall Electronics**  
(804) 974 6466 • FAX 6450

**ITC Delta I** stereo play \$800, ITC RP mono 3 tone \$550. Both recently rebuilt and warrantied. S Yates (804) 978-2888.

**SMC 590**, cart recorder in gd cond, mono R/P, newer style head gasket w/many spare parts, \$150. B Bailey, WHYR, POB 567, Saco ME 04072. 207-284-9600.

**Rapid-Q** mono player, \$95. G Dunn, 5383 Willow Lake Ct, Byron CA 94514. 510-516-0299.

**ITC R/P**, exc cond, \$750. R Statham, WSTU/WHLG, 1000 NW Alice Avenue, Stuart FL 34994. 407-692-1000.

**Audi-Cord S series** PB (3), 3 tone, gd cond w/spares, \$500. J Schloss, KICD-AM/FM, 2600 N. Hiway Blvd, Spencer IA 51301. 712-262-1240.

**ITC PD-II (3)**, mono, \$250 ea or all \$600. L Fuss, WDTL-FM, POB 1438, Cleveland, MS 38732. 601-846-0927.

**No matter how you stack it... Nobody reconditions tape heads like JRF.**

- Leads restored to new performance spec at a fraction of new cost
- Cart machines and all open reel formats
- Full line of replacement heads for all manufacturers

Experience the difference experience makes. Ask around. Nobody treats you or your heads better than JRF.

**JRF MAGNETIC SCIENCES**  
249 Kennedy Rd. Greendell NJ 07839  
(201) 579-5773 Fax (201) 579-6021

**Ampro mono play (5)**, good condition, \$100 ea; Ampro mono R/P, gd cond, \$200. G Kombuth, A&J Recording, 225 W 57th St, New York NY 10019. 212-247-4860.

**ITC SP stereo reproducers (3)**, need work, \$350 ea. T Lewczyk, WLTJ FM, 7 Parkway Ctr #780, Pittsburgh PA 15220. 412-922-9290.

**ITC 99-B** cart record/play deck, all options, \$3500; (2) ITC SP's, modified to 99-B specs, \$700 each. All equipment like new, home use only. 810-435-3932.

**Gates Cartrilape II**, R/P, \$300; play deck, \$200, ITC 760 R-R, \$250. E Moody, KJEM/KESE, 216 N Main St, Bentonville AR 72712. 501-273-9039.

**Spotmaster 505**, gd heads, looks and works like new, \$250. R Franklin, SSS, 1004 Dekalb St, Norristown PA 19404. 215-646-7788.

**ITC 99B stereo (4)**, mono PB (6), Harris stereo PB, Audi-Cord stereo PB. J Phillips, 414 Washington Ave, Defiance OH 43512. 419-782-8591.

**Want To Buy**

**ITC 800 series** mono R/P (2), deck PB (2); mono R/P stereo (2); Gates stereo 10 chnl board. D Thompson, Bdct Engr Consultants, 2740 Cherry Ln, Walnut Creek CA 94596. 510-933-4881.

**ITC, BE, Fidelipac** cart machines: single, triple, mono, stereo, play & record/play. Call M O'Drobinak @ 619-758-0888.

**CASSETTE & REEL-TO-REEL RECORDERS**

**STUDER SERVICE SPECIALIST**  
Thousands Served • Unbeatable Rates  
Precision Capstan Resurfacing  
**Audio Advantage**  
Tel (615) 742-3834  
**PRICE-QUALITY-SERVICE**  
*Let Us Prove It*

**Want To Sell**

**Tascam 322** channel recorder/ reproducer, excellent condition, remote, \$700; remote dbx unit control signal, punch in/out remote. 619-582-3356.

**Sony TCD-D7** portable recorder, \$600. R Suracci, Fine Art Productions, 67 Maple St, Newburgh NY 12550. 914-561-5866.

**Otari ARS-1000 (5)**, BO. R Wynne, KFLS/KKRB, POB 1450, Klamath Falls OR 97601. 503-882-4656

**Revox PR99 (2)** one working, \$1800; one not working, \$500/BO. J Kesler, WOBZ, POB 446, Livingston KY 40445. 606-843-9999.

**Tascam DA-30** digital audio tape deck, new, remote control, users manual, warranty, \$995 + shipping. D Lent, WHKS Radio, 817 N Main St, Port Allegany PA 16743. 814-642-7004.

**Sony F1** digital PCM (2) for 2 ch link or rec on VCR, \$1800 both. T Markham, The Warehouse Studio, 2071 Emerson St, Jacksonville FL 32207.

**Teac AH010S** like new w/box, \$150; Teac A1500U, like new, low hrs, \$200; Pioneer RT 701, new heads, \$300; Viking Telex RD84 record amps (3), \$80 ea. J Parsons, Parsons Sound Service, 2781 Fayson Circle, Deltona FL 32738. 904-532-0192.

**HEAD RELAPPING/ REPLACEMENT**  
All tape and film formats  
30 years experience



350 N. Eric Drive  
Palatine, IL 60067  
708-358-4622

**Akal 6 x 9**, 3 motor, 3 head, \$50; Toshiba PC G30, 2 motor 2 head, \$30; Sony TCM 5000 EV, portable, \$125. G Dunn, 5383 Willow Lake Ct, Byron CA 94514. 510-516-0299.

# EMPLOYMENT

To place ads in this section, use the ActionGram form. To respond to box numbers write Radio World, PO Box 1214, Falls Church, VA 22041. Attn: \_\_\_\_\_

**HELP WANTED**

**SENIOR TEST & QC TECHNICIAN** Pacific Recorders & Engineering Corporation, a leading manufacturer & systems integrator for the broadcast industry, offers a challenging career opportunity for a qualified Senior Level Production Technician. This position is for a "self-starter" who enjoys the rewards of producing the highest quality audio products for the nation's leading broadcasters.

**QUALIFICATIONS:** • Minimum 5 years experience with broadcast audio products. • Mastery of troubleshooting skills as applied to analog, digital & microprocessor circuitry. • Competency with electrical as well as electro-mechanical assemblies.

**RESPONSIBILITIES:** • Exercise leadership skills toward meeting demanding production schedules. • Ensure all products meet Pacific Recorders' high standard of quality.

Pacific Recorders & Engineering Corporation is a firmly-established company with an industry-wide reputation for building the highest quality products & systems in the broadcast market. Located in the coastal community of Carlsbad, in Southern California, we provide a positive working environment & exceptional benefits, including the opportunity for unlimited personal growth. Please submit resumes, including references, & salary history to:

Ms. Patti Watson, Personnel Manager, Pacific Recorders & Engineering Corp.  
2070 Las Palmas Drive, Carlsbad, CA 92009

**CHIEF ENGINEER:** Immediate opening for Chief Engineer for 4 Class B FM radio stations in one of the most attractive cities in the Midwest. Minimum of 5 years experience and S.B.E. certification required. Knowledge of high power Continental and Harris FM transmitters is essential, along with the ability to troubleshoot audio and RF equipment to the component level. Stations are currently upgrading from analog to digital in both production and on-air environments. Salary \$35,000+. Full medical package, car, 401(k) plan. EOE, M/F/H. Please send resume with at least 3 professional references to:

**Mr. Charles Stone**  
Broadcast Services  
1650 Tysons Blvd.  
Suite 790  
McLean, VA 22102

**ABOUT OUR EMPLOYMENT SECTION**

**HELP WANTED**

Any company or station can run "Help Wanted" ads for \$1.50/word or buy a display box for \$60/column inch. Payment must accompany insert, use your MasterCard or VISA; there will be no invoicing. Blind box numbers will be provided at an extra charge of \$10. Responses will be forwarded to listee, unopened, upon receipt. Call 800-336-3045 for details.

**POSITIONS WANTED**

Any individual can run a "Position Wanted" ad, FREE of charge (25 words max), and it will appear in the following 2 issues of Radio World. Contact information will be provided, but if a blind box number is required, there is a \$10 fee which must be paid with the listing (there will be no invoicing). Responses will be forwarded to the listee, unopened.

Mail to: BROADCAST EQUIPMENT EXCHANGE  
PO Box 1214, Falls Church, VA 22041 Attn: Simone Mullins

**CHIEF ENGINEER**

WCTC (AM)/WMGQ (FM), Greater Media's central New Jersey radio stations, seek a qualified chief engineer to head a three man department at one of the country's top suburban radio operations. WCTC is a 24 hour news/talk/sports with a heavy remote schedule. WMGQ is a live A/C. A highly experienced and motivated pro is needed to manage the technical operation of these major market quality facilities. Competitive salary/full benefits. Resumes to: Mildred K. Smith, Greater Media Inc., PO Box 1059, East Brunswick, NJ 08816

**A Greater Media Station**  
Equal Opportunity/  
Affirmative Action  
Employer

**Full Time Engineer Needed**

We have an opening for a Full Time Engineer at Yakima Washington's premiere radio stations. K-I-T is a non-directional 5 kW AM. K-A-T-S is a Class C FM & K-X-X-S is a Class B FM. Our Chief Engineer must be familiar with the needs of these 24-hour radio stations & be willing to see that they are running at their optimum capabilities. If you are interested then send your resume ASAP to:

**INGSTAD BDCTG INC**  
Ric McClary, Ops Mgr  
POB 1280, Yakima, WA 98901

**BROADCAST ENGINEER/ FIELD SERVICE SUPERVISOR:**

Established Nationwide FM sub-carrier paging company is seeking a broadcast engineer with strong transmitter and SCA experience, demonstrated ability in signal propagation, standards & compliance, data transmission, instrumentation & measurement skills and field personnel supervision. Candidate must be immediately available and able to travel. Resumes only to Cue Paging Corporation, Attn: Human Resources, 2737 Campus Drive, Irvine, CA 92715 EOE M/F

**POSITIONS WANTED**

**True entertainment value** w/unique style, witty, cynical, confident, copywriting and prod whiz kid. Tom, 918-622-2079.

**Let's make millions together!** Programming, sales & tech genius w/exclusive new talk/music fmt, looking for major mkt to kick it off. Bill, 813-844-3823.

**News, Wx, Sports & Sidekick** guy w/degree willing, for reasonable \$ and job satisfaction, to move to your station, and begin contributing day one. Jim, 208-234-7549.

**14 yr pro** from Akron-Canton seeks FT AOR, CHR, or Hot AC gig. R Allen, 216-773-1549.

**Recent grad** w/on-air, journalism, prod & sales exp, seeking news or prod position, looking for a challenge. J Johnson, 336 NE 178th St, Seattle WA 98155. 206-364-7808.

**I know** there is a position open for a creative, fun-loving, hardworking air personality who likes to exp w/production. Brad, 405-722-2846.

**Marketable, motivated air-talent** seeks change, medium/major market, exp w/many fmts, currently doing A/C, great references. Jay, 413-532-9135.

**Hard working guy** willing to work in country or contemporary Christian sm, can handle on-air, production or news. S Weller, 918-358-5154.

**Be Unorthodox!** Call and hire Janet, FT announcing, programming aspirations, computer literate, in radio since 1980, PT announcing, marketing experience. Metros, bedroom communities preferred. Janet, 502-895-5888.

**Country/A/C** current A/C morning drive/MD w/great phones & brains, prefer anywhere east of CA. Mike, 510-988-9005.

**ADVERTISE!**  
...it's good for business!

800-336-3045

**HELP WANTED**

## FEDERAL PROGRAM LETS YOU WORK FROM YOUR HOME

- ☆ IN YOUR SPARE TIME
- ☆ SET YOUR OWN HOURS
- ☆ NO EXPERIENCE
- ☆ NO TRAINING NEEDED
- ☆ GUARANTEED INCOME
- ☆ BE YOUR OWN BOSS

CALL NOW

713-587-5407

1-800-618-8554

D. & K. ASSOC.

6180 HWY, 6 N. STE. # 257 HOUSTON, TX 77088

**CASSETTE & R-R...WTS**

**Revox 77A (2)**, 1/4" 2 trk 7.5/15, port case, very fine cond, \$500 ea; Scully 280A 1/4" 2 trk, 7.5/15, Russlang console cabinets, very fine cond, \$500 ea. G Kombuth, A&J Recording, 225 W 57th St, New York NY 10019. 212-247-4860.

**Otari MX5050 IIB**, Tascam 40-4, 24-2, Technics 1520. J Phillips, 414 Washington Ave, Defiance OH 43512. 419-782-8591.

**STUDER/REVOX**  
Factory Authorized Service  
"Superlative Service"  
**STUDIO-SONICS**  
450 W. Rand Road  
Mt. Prospect, IL 60056  
**708-670-0025**

**Ampex 440C**, 4 tracks, 4+2 track head stacks, roll around, needs work, pick up only, \$350; Uher 4200 + 4000, need work \$100 for all. Bob, 212-219-3670.

**Wollensak 1520 AV R-R** w/built in compressor, 10 W amp & spkr, w/some new blank tapes, \$80. R Franklin, SSS, 1004 Dekalb St, Norristown PA 19404. 215-646-7788.

**Tascam 1/4" 4 trk, R/R**, like new, 3 yrs old, \$1750; Tascam 1/4" 2 trk, R/R, like new 3 yrs old, \$1250. Kacee Production Agency, POB 712, Luverne MN 56156. 507-283-4588.

**NORTRONICS REPLACEMENT TAPE HEADS**  
Test Tapes, Degaussers, Gauges, Cleaners, Swabs, Lapping Films, Splice Bars/Tabs, and Demagnetizers  
**SEQUOIA ELECTRONICS**  
4646 Houndshaven Way  
San Jose, CA 95111  
(408) 363-1646  
FAX (408) 363-0957

**Otari Mark II-IV 1/2" 4-track**, multi-track, mint, less than 50 hours, Best Offer. R Kaufman, Pams Productions, POB 462247, Garland TX 75046. 214-271-7625, after 3PM CDT.

**16 track 2" \$3450**, MCI JH110C-8 \$2800, 110C-8 play only \$500, ATR800 mono or Tascam 7300 or 2502 \$600 ea, MCI Locator III \$1195, Tascam 52 2 trk \$1200, Ampex AG350 electr \$50/ch. W Gunn 619-320-0728.

**Scully '100' recorders**, record/play amplifiers, 8, 16, 24 track heads. Sequoia Electronics, 4646 Houndshaven Way, San Jose CA 95111. 408-363-1646.

**Otari 5050 MK III-8 trk**, heads excellent, \$2450. Wayne Gunn 619-320-0728.

**REVOX PARTS/SERVICE**  
Cassette-CD-Open reel  
Rebuilt A77s, \$850.00  
Capstan resurfacing, ALL BRANDS.  
**JM TECHNICAL ARTS**  
30 Music Sq. W. #156  
Nashville, TN 37203 (615) 244-6892

**Recordex 6 cassette rewriter** \$100; Tascam 40-4 4 track 10" in flight case with free dbx \$750; MRL new short test tapes \$39 for 1/4" to \$199 for 2". W Gunn 619-320-0728.

**Otari MX5050BII (2)** at DIRT CHEAP prices for P/T at NCE-FM station. Robert 214-226-2949.

**Otari Mark III-2**, two tracks (2) modified to full track, good condition, \$1000 ea, changed to two-track, \$1750, plus shipping. Klay 801-272-1814.

**Want To Buy**

**Ampex ATR100 taperecorders** for parts. Circuit cards, heads, motors, machine parts, or electronic parts. Call 818-907-5161.

**Ampex tube recorders and mixers.** W Gunn, 619-320-0728.

**Tascam 58 1/2" 8 track** wanted to buy or trade for Otari 5050 MK III-8 or...? Wayne Gunn 619-320-0728.

**CD PLAYERS**

**Want To Sell**

**Denon 950F.** J Phillips, 414 Washington Ave, Defiance OH 43512. 419-782-8591.

**Denon 950FA**, perf cond, \$650. K Thomas, Rebel Recording, 5555 Radio Lane, Jacksonville FL 32205. 904-388-7711.

**TEC SLP101**, \$150. Kacee Production Agency, POB 712, Luverne MN 56156. 507-283-4588.

**MSD superdisk drive** for Commodore-64 & VIC-20 with many programs, \$100. R Franklin, SSS, 1004 Dekalb St, Norristown PA 19404. 215-646-7788.

**Want To Buy**

**CD controller**, hardware &/or software to control Pioneer 18 disc CD players, for continuous music service. G Finney, WPWB, 7137 Heather Lane, Macon GA 31206. 912-788-2124.

**COMPUTERS**

**Want To Sell**

**IBM RT-PC A1X**, about 60 programs, adv operating, interactive system, will trade; Samsung Syncmaster, SVGA 14", \$360. R Suracci, Fine Art Productions, 67 Maple St, Newburgh NY 12550. 914-561-5866.

**EFI uninterruptible power supply**, 500 watt, new in box, \$350. Klay 801-272-1814.

**Want To Buy**

**Tandy 6000HD** w/at least 1 floppy drive. Mel Crosby, 408-363-1646, FAX 408-363-0957.

**CONSOLES**

**Want To Sell**

**BE 5S250**, 5 channel, \$2175/BO; BE 5S25 8 channel stereo, \$3000. J Kesler, WOBZ, POB 446, Livingston KY 40445. 606-843-22A 9999.

**Auditronics 501** 26 inputs, 16 outputs, built in patch bay, 4 effects sends, 4 effects returns, 6 aux sends, flexible routing, \$4900. T Burr, KSFO, 300 Broadway, San Francisco CA 94133. 415-398-5600.

**Radio Shack 32-1200**, 3 mic w/pan post, 2 line, 2 turntable inputs, cue & headphone amp, \$50; Gates Yard, 6 chnl wall parts except electronics, \$100. G Dunn, 5383 Willow Lake Ct, Byron CA 94514. 510-516-0299.

**EV/Tapco 100M** powered mixer, 10 inputs, 2 built-in 150 W amps, phantom power, monitor send, reverb, 16 band EQ, slide faders, only 36 lbs, w/case, \$800/BO. R Shull, WFAS AM/FM, POB 551, White Plains NY 10602. 914-693-2400.

**Auditronics 110**, 12 mono chnls w/faders, 2 stereo chnls, 3 remote starts, inc Auditronics PS-30 w/nice custom console furniture w/space for 2 deck mounted R-R recorders, \$850. B Lacy, WAVQ FM, 3611 Soncy 6A, Amarillo TX 79121. 806-355-4000.

**Tascam 8 channel**, like new, \$850. Kacee Production Agency, POB 712, Luverne MN 56156. 507-283-4588.

**Cetec 5 chnl mono**, mounted in prot console cabinet w/cue speaker, program speaker & equip shelf, \$750. E Moody, KJEM/KESE, 216 N Main St, Bentonville AR 72712. 501-273-9039.

**Gately pro-kit**, manual, rough, \$75. Bob, 212-219-3670.

**COMPUTERS**

**Presto 900-A1** antique portable mixing amp (1940's), used w/early disk & tape recorders, 3 balanced mic inputs, \$250. R Franklin, SSS, 1004 Dekalb St, Norristown PA 19404. 215-646-7788.

**Realistic stereo mixing console** 32-1200B, \$100; Sparta A-20B, 8 chnl mono console, \$1000; Meteor Clubman 1-5 stereo sound mixer, \$75; Shure M-63 audio master, \$75. P Bridger, KGKO, 202 E Cross, Benton AR 72015. 501-778-8257.

**BE 10S350A** 10 chnl stereo slide fader, mint, complete docs, \$2300. G Kombuth, A&J Recording, 225 W 57th St, New York NY 10019. 212-247-4860.

**Russco 505 mono (2)**, 1 rack mount, 1 table top, \$250 ea. J Parsons, Parsons Sound Service, 2781 Fayson Circle, Deltona FL 32738. 904-532-0192.

**ADM ST 160II**, 4 track, audio prod console w/many extras, B/O; Andrew HJ5-75 7/8" air coaxial cable, 407 roll, 422 roll, 650' roll, new in 1981, stored, never used, still in shipping reel, B/O you ship & remove from bldg. J Book, WOC Radio, 3535 E Kimberly Rd, Davenport IA 52807. 319-344-7000.

**Harris Stereo 80**, 8 chnl, solid state, \$1000; Harris Gatesway 80, 8 chnl mono, solid state, \$800. L Fuss, WDTL-FM, POB 1438, Cleveland MS 38732. 601-846-0927.

**Ramko DC5AR** 5 channel mixers, vgc, \$175 each. 916-725-2434.

**FINANCIAL SERVICES**

**EQUIPMENT FINANCING ON ALL RADIO EQUIPMENT**

- Easy to qualify
- Fixed-rate, long-term leases
- Any new or used equipment
- 100% financing, no down payment
- No financials required under \$50,000
- Refinancing existing equipment

**ENF** EXCHANGE NATIONAL FUNDING  
Call Mark Wilson (800) 275-0185

**DISCO-PRO SOUND EQUIPMENT**

**Want To Sell**

**Fender 6 input**, 400 W. R Suracci, Fine Art Productions, 67 Maple St, Newburgh NY 12550. 914-561-5866.

**TEC SBCX300 8" 2-way speakers (2)**, \$250. Kacee Production Agency, POB 712, Luverne MN 56156. 507-283-4588

**JBL ceiling speakers (2)**, used in suspended ceilings, incl housing, speaker, control knob, \$30 ea; Lil Miss Moffat 48 V phantom power supply (2) \$18 ea; new 6" rack rails (2), \$18 ea, other sizes available free w/purchase, all items plus shipping. B Lord, Lord Broadcasting, 13313 SE 208th St, Kent WA 98042. 206-631-2374.

**JBL speakers 2404 HF**, 2445 horns, 2204 mids in 2 cabinets, \$1400; HME MX 10, stereo 8 chl rack mixer, \$300. D Kochoer, Digital Sound Makers, 1919 Hanover Ave, Allentown PA 18103. 610-776-1455.

**LIMITERS**

**Want To Sell**

**CRL SMC-600A** stereo modulation cntrlr, \$250. B Lacy, WAVQ FM, 3611 Soncy 6A, Amarillo TX 79121. 806-355-4000.

**CRL stereo preparation processor** 5PP-800, \$1300; CRL AM stereo matrix processor, \$1600/BO. J Kesler, WOBZ, POB 446, Livingston KY 40445. 606-843-22A 9999.

**Altec 1591A** compressor, \$225. A Garren, KPDQ, 5110 Stark, Portland OR 97215. 503-231-7800.

**Aphex 104 Aural Exciter w/Big Bottom**, like new, \$200. K Thomas, Rebel Recording, 5555 Radio Lane, Jacksonville FL 32205. 904-388-7711.

**Kahn Symmetra-peak SP 58 1A (AM)** \$25. P Bridger, KGKO, 202 E Cross, Benton AR 72015. 501-778-8257.

**Want To Buy**

**UREI BL-40** Modulimiter mono compressor limiter, \$150. R Chambers, 3015 Johnstonville Rd, Susanville CA 96130. 916-257-2121.

**Composite clipper and Aural Exciter**, buy or trade. E Moody, KJEM/KESE, 216 N Main St, Bentonville AR 72712. 501-273-9039.

**Wilkinson LA2-CS** stereo limiter, \$75; Wilkinson LA2-C mono limiter, \$50; MAP 1694 audio equalizer, \$50; Shure SR 107 audio equalizers, \$75. P Bridger, KGKO, 202 E Cross, Benton AR 72015. 501-778-8257.

**Orban XT 2** accessory chassis, \$1500, UREI stereo pair LA 4 compressors, \$500 pr; Orban 418 stereo limiter, \$500; Vigilante stereo processor, \$1500. T Lewczyk, WLTX FM, 7 Parkway Ctr #780, Pittsburgh PA 15220. 412-922-9290.

**Orban 8100/XT2**, DADs (2), CRL SEP-800, PMC-300, Dynafex DX-2, Aphex II exciter, UREI LA-3 (2). J Phillips, 414 Washington Ave, Defiance OH 43512. 419-782-8591.

**Harris MSP95/MSP90** stereo generator, AGC & limiters, \$2500. T Beschta, WAQE, POB 703, Rice Lake WI 54868. 715-234-9059.

**Want To Buy**

**Orban Optimod 8000** and 8100; Harris stereo triband AGC. B Lacy, KEMA FM, 3611 Soncy 6A, Amarillo TX 79121. 806-355-4554.

**Fairchild 670 or 660 tube compressor/limiter**, Teletronics LA-2A tube compressor/limiter or UREI LA-3A solid state compressor/limiter, call after 3PM CST 214-271-7625.

**MICROPHONES**

**Want To Sell**

**Nady 151 VR** wireless, lavalier, \$60. G Dunn, 5383 Willow Lake Ct, Byron CA 94514. 510-516-0299.

**Audio Technica C87**, \$125; mic flags w/your logo. R Suracci, Fine Art Productions, 67 Maple St, Newburgh NY 12550. 914-561-5866.

**Lectrosonics CR185-M185** VHF wireless mics (2), mint cond, \$1100 ea; Vega 67B-77D2 wireless mics, exc cond, portable (2), \$1000 ea. Don, Scales Film Sound, 3142 Market Place, Bloomington IN 47403. 812-339-4446.

**EV Variable D** cardioid mic, comp w/arm & bench mount, \$500. Kacee Production Agency, POB 712, Luverne MN 56156. 507-283-4588.

**Sennheiser MD421**. J Phillips, 414 Washington Ave, Defiance OH 43512. 419-782-8591.

**RCA 77DX (1)**, RCA 44BX (1), both in exc cond, BO over \$800 for either. R Burns, RF Studios, 1326 Hignmeadow Dr, Garland TX 75040. 214-271-4386.

**Manley Labs CR3A**, new, \$795 w/shockmount, windscreen & case, no risk trial in your studio. Also have used mics & everything else. Get our catalog! Liberal trade policy too. Audio Village, 619-320-0728.

**Want To Buy**

**Shock mount for RE-20**. B Holloway, WPGU, 204 E Peabody Dr, Champaign IL 61820. 217-333-2016.

**Neumann U87s**, KM84s, AKG 451s, EV RE20s, Sennheiser 421s. W Gunn 619-320-0728.

**RCA 77DXs/44BXs** ribbon, chrome/TV grey, gd cond, BO. R Kaufman, Pams Prods, POB 462247, Garland TX 75046. 214-271-7625, after 3PM CDT.

**77-DX's, 44-BX's, WE KU-3A's** On-Air lights, recording lights & audition lights. Top price paid. Fast response. Bill Bryant Mgmt, 2601 Hillsboro Rd, G12, Nashville TN 37212. 615-269-6131, FAX: 615-292-3434.

**MISCELLANEOUS**

**Want To Sell**

**Gentner Versa Patch**, gd cond, \$150. B Lacy, KEMA FM, 3611 Soncy 6A, Amarillo TX 79121. 806-355-4554.

**19" equipment racks**, floor rack w/wheels, 76" of rack space ea (2), \$75; 48 jack patch bay w/many patch cables, \$100. G Dunn, 5383 Willow Lake Ct, Byron CA 94514. 510-516-0299.

**65 kW, 3 phase generator**, manual xfer, auto start, diesel, exc cond, low hr, \$8500. J Schloss, KICD-AM/FM, 2600 N Hwy Blvd, Spencer IA 51301. 712-262-1240.

**PHONE: 703-998-7600 FAX: 703-998-2966**



Call Simone Mullins, Classified Ad Manager, to reserve space in the next issue. Use your credit card to pay, we now accept VISA and MASTERCARD.

**Radio World**  
5827 Columbia Pike, 3rd Floor  
Falls Church, VA 22041

**Select from these categories for best ad positioning:**

- |                            |                           |                          |
|----------------------------|---------------------------|--------------------------|
| Acoustics                  | Consoles                  | Software                 |
| Amplifiers                 | Disco-Pro Sound Equip.    | Stations                 |
| Antennas & Towers & Cables | Financial Services        | Stereo Generators        |
| Audio Production (Other)   | Leasing                   | Tapes, Carts & Reels     |
| Brokers                    | Limiters                  | Tax Deductable Equipment |
| Business Opportunities     | Microphones               | Test Equipment           |
| Cart Machines              | Miscellaneous             | Transmitter/Exciters     |
| Cassette & R-R Recorders   | Monitors                  | Tubes                    |
| CD Players                 | Receivers & Transceivers  | Turntables               |
| Computers                  | Remote & Microwave Equip. | Positions Wanted         |
|                            | Satellite Equipment       | Help Wanted              |

**Classified Advertising Rates Effective January 1, 1994**

	1x	3x	6x	12x
1-9 col inch (per inch)	\$60	58	54	49
10-19 col inch (per inch)	55	52	49	44
Distributor Directory	100	95	90	85
Professional Card	65	60	55	50
Classified Line Ad		\$1.50 per word		
Blind Box Ad		\$10 additional		

To compute ad costs: Multiply the number of ad inches (columns x inches) by the desired rate schedule for your per unit cost. Example: a 3" ad at the 1x rate is \$180, at the 3x rate \$174, at the 6x rate \$162, at the 12x rate \$147, etc.

**DISTRIBUTOR DIRECTORY**

The following distributors serving the broadcast industry would be glad to help you with any of your requirements.

...HEY! Our gang thinks trying harder is fun...  
**.....TRY US!**  
RADIO! The beat goes on!  
**CROUSE-KIMZEY OF ANNAPOLIS**  
tops in broadcast equipment  
**1-800-955-6800**  
ask for Kathleen

**CORNELL-DUBILIER MICA CAPACITORS**  
FROM STOCK  
**JENNINGS VACUUM CAPACITORS**  
FROM STOCK  
**JENNINGS VACUUM RELAYS**  
**SURCOM ASSOCIATES, INC.**  
2215 Faraday Ave., Suite A  
Carlsbad, California 92008  
(619) 438-4420 Fax: (619) 438-4759

**MISCELLANEOUS...WTS**

**Mitsubishi C3479CP**, RGB, excellent condition, \$700 + shipping. R Suracci, Fine Art Productions, 67 Maple St, Newburgh NY 12550. 914-561-5866.

**Uniden UST-5000** satellite receiver with baseband output, Kenwood KA-3500 40 W stereo amplifier, Kenwood KT-5300 AM/FM tuner, Realistic 5 band equalizer, BE Spotmaster 500C cart machine, Teac X-3 MK3 7" reel deck, Best Offer/on any component. G Finney, WPWB, 7137 Heather Lane, Macon GA 31206. 912-788-2124.

**Parts for RCA BC-15/BC-18** consoles; parts for RCA RT27/BA 27 mono cart machines, esp motors & pinch rollers; Xtal 90.7 MHz, for Gates M6095 exciter, T9-D holder; Gates FM 250B blower for RF deck and interlock for rear door panel. B Wick, WYRS, POB 545, Manahawkin NJ 08050. 609-597-8089.

**Qume QVT-101** serial ASCII data terminals (4), great for remote dial-in, studio-to-control room comm, compatible with Gentners VRC-2000 for auto logging, \$35 ea. G Finney, WPWB, 7137 Heather Lane, Macon GA 31206. 912-788-2124.

**BE Phase Trak 90** manuals (4), \$25 ea; projection TV w/o stereo, \$500/BO. T Lewczyk, WLTJ FM, 7 Parkway Ctr #780, Pittsburgh PA 15220. 412-922-9290.

**Peerless S-542 F**, output transformer, \$45. R Links, Links Sound, 1656 California St, Berkeley CA 94703. 510-845-5557 eve.

**Tube output transformers**, UTC LS 18, WE 618. RQ Studio, Larson Rd, N Reading MA, 01864. 508-664-0174.

**Want To Buy**

**Tube output transformers** by WE, UTC, Triad, or any sideband audio transformer for output, esp UTC LS-40, LS-57, Triad HSM-184, WE 618B, 171A/C. RQ Studio, Larson Rd #4, N Reading MA 01864. 508-664-0174.

**Jazz record collections**, 10" LP/12" LP be-bop, swing, dixie, highest prices paid. B Rose, Program Recdgs, 228 East 10th, NNY 10003. 212-674-3060.

**Radio transformers** by Chicago, UTC, Triad, Peerless, Freed, Sola, send list. J Gangwer, 942 32nd St, Richmond CA 94804. 415-644-2363.

**MONITORS**

**Want To Sell**

**C-QUAM monitor**, \$3000. J Kesler, WOBZ, POB 446, Livingston KY 40445. 606-843-22A 9999.

**Gates MO-2696**, monitor amp, line amp, used GLG output tubes, \$200. R Franklin, SSS, 1004 Dekalb St, Norristown PA 19404. 215-646-7788.

**McMartin TBM 4500** modulation monitor, needs calibration, \$500. T Lewczyk, WLTJ FM, 7 Parkway Ctr #780, Pittsburgh PA 15220. 412-922-9290.

**TFT 760 EBS encoder/decoder** with AM receiver, good cond, works fine, no manual, \$200/BO. J Raynor, WLQE, 16 Village Sq, Moneta VA 24121. 703-297-1188.

**Belar FMM-2 & FMS-2**. M O'Drobinak, 619-758-0888.

**Want To Buy**

**EBS Receiver** encoder/decoder. B Wick, WYRS, POB 545, Manahawkin NJ 08050. 609-597-8089.

**McMartin TBM 4500** stereo FM mod monitor; McMartin TBM 4500 FM freq monitor. D Thompson, Bdct Engr Consultants, 2740 Cherry Ln, Walnut Creek CA 94596. 510-933-4881.

**McMartin (buy & sell)** any model. C Goodrich, 11435 Manderson, Omaha NE 68164. 402-493-1886 or fax 402-493-6821.

**RECEIVERS & TRANSCEIVERS**

**Want To Sell**

**Motorola SP3113171 Type CC3155** multi XFL, 2 freq repeater, carrier squelch & PL100.0 Hz, 10 W, RX158 MHz, TX152 MHz, \$500. B Dickerson, WEAG AM-FM, 1421 S Water St, Starke FL. 904-964-5001.

**SCA RECEIVERS—ALL TYPES**

Reading Service / Ethnic / Data Professional / Table Will work to meet your receiver needs

**DAYTON INDUSTRIAL CORP.** (Manufacturer) 2237 Industrial Boulevard Sarasota, FL 34234 Tel: 813 351 4454 FAX: 6081

**RCA tube type AM modulation monitor** (1963), \$200. P Bridger, KGKO, 202 E Cross, Benton AR 72015. 501-778-8257.

**AM STEREO RECEIVERS** From \$34.95 Portable, Home, Auto **RRADCO** Phone/FAX 708-513-1386

**AM stereo tuner**, \$25. P Bridger, KGKO, 202 E Cross, Benton AR 72015. 501-778-8257.

**Broadcast quality SCA modules.** Why pay a bundle when you can buy factory direct from Background Music Engineering, 1-800-944-0630.

**Want To Buy**

**HH Scott FM receivers** w/green or gray front panels. RQ Studio, Larson Rd, N Reading MA, 01864. 508-664-0174.

**REMOTE & MICROWAVE EQUIPMENT**

**Want To Sell**

**Moseley digital remote control system**, DRS-1 control terminal, remote terminal, selection unit (2), status panel (2); DLS-1 sampling terminal, sampling interface, printing terminal; TAU-3 tolerance alarm unit. B Lacy, WAVQ FM, 3611 Soncy 6A, Amarillo TX 79121. 806-355-4000.

**RENT IT HERE!** Call Steve Kirsch for Details

**COMREX** 1, 2, & 3-Line Extenders Switched 56/ISDN Systems

**TELOS** Zephyr Digital Phone Hybrids

**GENTNER** EFT-3100 3-Line Extenders

**SHURE** FP-410 Automatic Mixers

**REMOTE AUDIO PACKAGES**

**SILVER LAKE AUDIO • 516-623-6114 • FAX: 516-377-4423**

**Want To Buy**

**Moseley 303**, composite STL. B Lacy, KEMA FM, 3611 Soncy 6A, Amarillo TX 79121. 806-355-4554.

**Remote pickup system** in 450 band; satellite RX system, C baud, Zephyrs. B Wick, WYRS, POB 545, Manahawkin NJ 08050. 609-597-8089.

**950 MHz STL dishes**, 4' (2). B Lacy, KEMA FM, 3611 Soncy 6A, Amarillo TX 79121. 806-355-4554.

**QE1 ATS system** for FM. E Moody, KJEM/KESE, 216 N Main St, Bentonville AR 72712. 501-273-9039.

**SATELLITE EQUIPMENT**

**Want To Sell**

**Wegener 1601 series** w/1606-52 receiver card, 1626 dual demod, 1648 tone decoder, 1683-08 translator, 1644-01 relay cards (3), 1605-12 power supply, originally set up for Moody Broadcasting, \$900. G Finney, WPWB, 7137 Heather Lane, Macon GA 31206. 912-788-2124.

**Adcom 7550**, like new, \$1500. B Hill, KALK, 106 S Jefferson Ave, Mt Pleasant TX 75455. 903-577-9770.

**Wegener main frame** and mini-main-frame for Unistar. P Bailion, KMCM/KMTA, 1218 Pioneer Bldg, St Paul MN 35101. 612-222-5555.

**Wegener satellite electronics** for Unistar's AM only fnt, comp pkg \$3500; Wegener satellite card for CNN news, \$500. P Bridger, KGKO, 202 E Cross, Benton AR 72015. 501-778-8257.

**OuterSpace Experts!**

**We SELL \* TRADE \* BUY SATELLITE EQUIPMENT 317-962-8596**



**Fairchild 384 Dart receiver**, incl down converter, 15 kHz DATS card, 20 kHz SEDAT card, \$4500; 10' fiberglass dish. T Lewczyk, WLTJ FM, 7 Parkway Ctr #780, Pittsburgh PA 15220. 412-922-9290.0

## SERVICES

**OBSTRUCTION LIGHTING**

Beacons lights accessories

FAX inquiries on your letterhead to:

**ROHN** P.O. Box 2000 Peoria, Illinois 61656  
PH: (309) 697-4400  
FAX: (309) 697-5612

**LOCATION SERVICES IN THE UNITED KINGDOM**

Planning remotes from the U.K.? we provide a comprehensive service

- we organize venues for your shows
- we provide temporary equipment
- live links via ISDN/Switched 56
- experienced radio engineers
- we help you line-up guests

Contact New York (212) 229-9118  
Good Morning from Great Britain  
Wired for Sound Ltd., London N15

**REMOTE EQUIPMENT RENTALS**

**COMREX and GENTNER** 1, 2 & 3-Line Extender Systems  
Now With The New GENTNER EFT-3100 MARTI VHF/UHF RPU Systems  
Switched-56 Systems  
Call or FAX Dwight Weller  
**WELLER AUDIO-VISUAL ENGINEERING**  
Baltimore, MD  
Phone: (410 or 800) 252-8351  
FAX: (410) 252-4261

**Tower Sales & Erection**

Turnkey Site Development Installation & Maintenance  
AM/FM Broadcast, TV Microwave Systems, Antennas & Towers

**TOWERCOMM** Communications Specialists

**Ben Wall** President  
6017 Triangle Dr Raleigh, NC 27613 (919)781 3496  
Gen Contractor #25891 Fax (919)781 6454

**EVANS ASSOCIATES**  
Consulting Communications Engineers

TV • FM • AM • ITFS • Satellite  
FCC Applications, Design and Field Engineering

Video/Data/Voice • Light Fiber & Microwave • Wide-Area Networks & STL's

210 S. Main Street  
Thiensville, WI 53092  
(414) 242-6000 • FAX (414) 242-6045  
Member AFCCCE

**PC - SOFTWARE**

AM FM TV Search Programs  
Contour Mapping-STL Paths  
RF HAZ-1990 POP Count  
FAA Tower-Draw Tower

**Doug Vernier**  
Broadcast Consultant  
1600 Picturesque Dr  
Cedar Falls, IA 50613

**800-743-DOUG**

**MAL2 FM STUDY SOFTWARE**  
since 1987  
was \$995 — now only \$195  
Inexpensive quarterly data updates  
from the  
**Malleck Company, Inc.**  
**602-703-1009**

North America RF & Audio

**Mirkwood Engineering Services**  
Broadcast and Telecommunications Consultants

Multidiscipline Engineering and Planning Firm including • Application & Allocation Services

- Project, Engineering & Construction Management • Site Acquisition
- Rural & Remote Site Installations
- Field Service • Studio Design & Installation

50 Park Ave. Claremont, NH 03743 (603) 542-6784

**NRSC PROOFS**

For \$500, you can comply with the new \$73.44 spec & have the documentation in hand to prove it!

**MICROWAVE FREQUENCY SERVICES**

Services available in Southern/Central CA, AZ and NV. Group discounts available.  
Call 1-800-2-GET-LEGAL  
fax 310-425-6299 avail 24 hrs

**Where In The World Are You?**

Reach radio professionals worldwide by advertising in **Radio World's** international edition.  
Call Simone for more information.  
**1-800-336-3045**

**JEFFREY W. PEARCE**  
Professional Broadcast Technical Consultant

General Engineering Services

- Transmitter & Studio Site Upgrades & New Construction • STL/TSL Systems
- RPU/RENG Systems • Remote Control Systems
- Satellite Systems • Station Inspections

3131 N. Lewis Ave., Waukegan, IL 60087  
Phone 708-249-9140  
FAX 708-336-6497

**Teletech, Inc.**

BROADCAST CONSULTANTS AND ENGINEERS

- FCC Applications & Field Engineering
- Frequency Searches & Coordination
- Tower Erection & Maintenance
- Facility Design & Construction

CONTACT:  
**Kenneth W. Hoehn**  
23400 Michigan Ave  
Dearborn, MI 48124  
(313) 562-6873

**T. Z. Sawyer**  
Technical Consultants  
**1-800-255-2632**

- FCC Applications & Exhibits
- Frequency Studies - Class Upgrades
- Directional Antennas - AM/FM/TV
- High Power Antenna Arrays

Telefax: (301) 913-5799  
6204 Highland Dr., Chevy Chase, MD 20815

**Don't Gamble with your advertising dollars!**

Advertise in Radio World & reach 22,000+ subscribers.  
Call Simone at  
**1-800-336-3045 today!**

**Contact Radio World Newspaper for availabilities**

**P.O. Box 1214 Falls Church VA 22041**

**1-800-336-3045**





**SATELLITE EQUIPMENT...WTS**

Wegener mainframe and mini-mainframe for Unistar. P Bailion, KMEM/KMTA 1218 Pioneer Bldg. St Paul MN 55101. 612-222-5555.

**At Last!**  
**A New**  
**Dats/Sadat**  
**Digital**

*Ariel*  
**Shipping Now!**  
**LNB System**  
**Dart 384**  
**Compatible**  
**New 7.5/15 KHz**  
**Dats Card**

**24 Hour**  
**Phone / Fax**  
**Technical Support**  
**All Networks**  
**& Receivers**  
**Satellite Systems**  
**(719) 634-6319**  
**(Fax) 635-8151**

**Want To Buy**

Fairchild Dart 384 needs voice cue. J Poole, KMAG-KWHN, 423 Garrison Ave, Ft Smith AR 72901. 501-782-8888.

Adcom 7550 SCPC satellite, buy or trade. E Moody, KJEM/KESE, 216 N Main St, Bentonville AR 72712. 501-273-9039.

**SOFTWARE/ DATABASES**

**Want To Sell**

**PC SOFTWARE** for Broadcasters. Traffic, Billing, & Accounting. Powerful, inexpensive. Works with automated, satellite or live operations. INTERFACES with popular DIGITAL AUTOMATION SYSTEMS. Try it for 90 days, no obligation.  
**Absolute Broadcast Automation**  
Naples, Florida (813) 643-3689

**HOT MIX**  
Music Scheduling Software  
Buy-out \$495.00  
— Call today for a demo —  
**LA PALMA BROADCASTING**  
**(714) 778-6382**

**STATIONS**

**Want To Sell**

16A IO5B Person to lease/purchase stn for small beach town on West coast of FL, monthly payments as low as \$4000. B Lacy, WAVQ FM, 3611 Soncy 6A, Amarillo TX 79121. 806-355-4000.

You could own a working 100,000 Watt FM Radio Station for \$25.00. For information send \$3.00 to: Business Ventures PO Box 642, Rock Springs, Wyoming, 82903

**Want To Buy**

Bdct group seeks FM commercial stn in IN, IL, OH, MI. Vera, POB 48267, Evergreen Park IL 60642. 312-445-9200.

Looking for dark or troubled AM, FM, or AM/FM combo, with little or no money down, we have expertise to turn it around. FAX info to 219-665-6427.

LBA, CP or DARK, South and East of Ohio and Mississippi Rivers, Florida included. D Gibson, 214-684-4907.

**STEREO GENERATORS**

**Want To Buy**

SCA generator, 67 kHz for music application. G Finney, WPWB., 7137 Heather Lane, Macon GA 31206. 912-788-2124.

**TAPES/CARTS/REELS & CD's**

**Want To Sell**

Fidelipac 300 carts, \$10 for lot + shipping; Ampex 7" boxes, as new, 40/\$12 + shipping; Ampex 407, 7" reels, used, no splices, 2/\$5 + shipping. M Saady, First City Recording, 213-05 75 Ave, #22, Bayside NY 11364.

Pepper Tanner library, including sound effects category and jingles, great for collectors, good condition, 305 discs, \$199 + shipping. P Tinkle, WCMT Radio, POB 318, Martin TN 38237.

## MARATHON PRODUCTS COMPANY

### Audio Cartridge Rebuilding Division

Rebuilding/reloading, like new, all brands, any length up to & including 3.5 minutes, \$1.95 ea. FOB out plant, 48 hrs delivery. (New rate effective 9/1/93)

**New NAB Marathon cartridges prices on request.**

*35 Years professional experience!*  
Lifetime member AES R.D. MYERS Sr.  
Manufacturers of Audio Devices,  
Continuous Tape Mag.

69 Sandersdale Rd. Charlton, MA 01507  
1-508-248-3157 or 1-508-853-0988

Circle (84) On Reader Service Card

80 reels country music w/cues, song list w/ea reel, \$5/ea + shipping. D Sports, WCLA-FM, POB 427, Clayton GA 30417. 912-739-3035.

100 asst'd new CDs in boxes, \$200 + shipping; Denon 120 tapes, new, \$8 ea. R Suracci, Fine Art Productions, 67 Maple St, Newburgh NY 12550. 914-561-5866.

Ampex 406/456 1/4" tape (82 reels), exc cond; also Ampex 406/456 (61 reels), gd cond, \$100/BO. R Herman, Frontier Radio, POB 9292, Austin TX 78766. 512-258-7505.

Classic library, all on 7" reels, \$300. D Pulwers, Dave's Price Audio, 310 N Howard St, Alexandria VA 22304. 703-751-9346.

Scotchcart II's, like new 4.5 to 5.5 min, \$1.59 ea; 100 qty \$1.49 ea; take all 300 for \$1.20 ea. D Nuechterlein, 6130 Dehmel Rd, Frankenmuth MI 48734. 517-652-6863.

Russ Lang cart rack/tower, like new, holds 864 carts, w/casters, \$200 + shipping. R Zom, WMHR, 4044 Makyas Rd, Syracuse NY 13215. 315-469-5051.

1960's & 1970's records, easy listening, 12 in, stereo, good cond, \$99 for 100. R Franklin, SSS, 1004 Dekalb St, Norristown PA 19004. 215-646-7788.

Pams Jingles ref tapes, 1951-1976, BO. R Kaufman, Pams Prods, POB 462247, Garland TX 75046. 214-271-7625.

**Want To Buy**

Pre-recorded open reel tapes, including master dubs, RCA, Mercury, Livingston, Westminster, etc, 2 track, in-line or stacked heads, all categories, labels and artist. P Chance, Imperial Analog, 925 Clinton Street, Philadelphia PA 19107, 215-574-8147.

Fidelipac/Audiopak Mastercart II gold or AA-4 light blue in 2:30 through 4:00 lengths, must be in vgc, call after 3PM CST. 214-271-7625.

**TAX DEDUCTIBLE**

Non-profit Christian High School preparing to teach students bdct industry, need all types of equip & supplies incl console, cart machine, R-R deck, turntable & tonearm, mics, preamps, etc, contribution is tax deductible. D Potter, Bethany Christian High School, POB 163, Jackson MN 56143. 507-847-4429.

New non-comm station seeking EBS decoder/encoder, cart machines (mono), any unwanted from mic to antenna. B Wick, WYRS, POB 545, Manahawkin NJ 08050. 609-597-8089.

Non-profit 501-C3 cart machines, R/R and SCPC, on 63.10. J Hayes, 1101 NW 43 Pl, Des Moines IA 50313. 515-244-2848.

Off shore missionary network needs STL, non FCC approved ok, will pay shipping or PU. K Starcher, 1570 Meriline, Cuyahoga Falls OH 44221. 216-920-8035.

**TEST EQUIPMENT**

**Want To Sell**

Leader LBO 518 100 MHz scope. J Phillips, 414 Washington Ave, Defiance OH 43512. 419-782-8591.

**TRANSMITTERS**

**Want To Sell**

Singer 2.5 kW w/exciter, filter, \$5000. J Schloss, KICD-AM/FM, 2600 N. Hiway Blvd, Spencer IA 51301. 712-262-1240.

QEI Q30000, 1989 30,000 W FM xmtr, exc cond, \$28,500. J Davis, SCB Inc, POB 7762, Amarillo TX 79114. 806-355-1187.

Continental Electronics 1100 W on 1590, \$8000/BO. J Kesler, WOBZ, POB 446, Livingston KY 40445. 606-843-9999.

**FM - TRANSMITTERS**

Factory new not used. Why buy a used Transmitter when you can own a new FM Transmitter for about the same cost? Call JIMMIE JOYNT at 214-335-3425.

CSI 3kW, 1981 single phase, exc cond, \$10500. J Davis, SCB Inc, POB 7762, Amarillo TX 79114. 806-355-1187.

C-QUAM exciter, \$3000/BO. J Kesler, WOBZ, POB 446, Livingston KY 40445. 606-843-22A 9999.

**DEMOED EQUIPMENT**

BEXT Inc. has a few demoed exciters, amplifiers and STL's for sale. All demoed systems are sold first come first served and have the same 2 year warranty as BEXT's new equipment. For information: 619-239-8462

Gates BC 500GV, parted out, everything avail except mod reactor & capacitors, 1 part or all. J Mathis, WCS1, 3212 Washington St, Columbus IN 47203. 812-372-4448.

Harris FM 2.5, 1980 w/exciter, \$8500 T Beschta, WAQE, POB 703, Rice Lake WI 54868. 715-234-9059.

**NEW 3 kW FM transmitters**

for under \$14,000.  
Call for details  
Bill Hoffman  
**518-743-1601**

RCA BTA 1R1 AM xmtr 850 khz, 1963, will retune to any freq, \$2500. P Bridges, KGKO, E Cross, Benton AR 72015. 501-778-8257.

**We've Blown Away the Biggest Myth in the FM Transmitter Business... "Quality FM Transmitters are Expensive...!"**

**The "ECO Series"...**

- Top Quality
- Excellent Reliability
- Feature Packed

**BUDGET PRICED!**

**The 'Next Transmitter Generation' is here NOW!!**

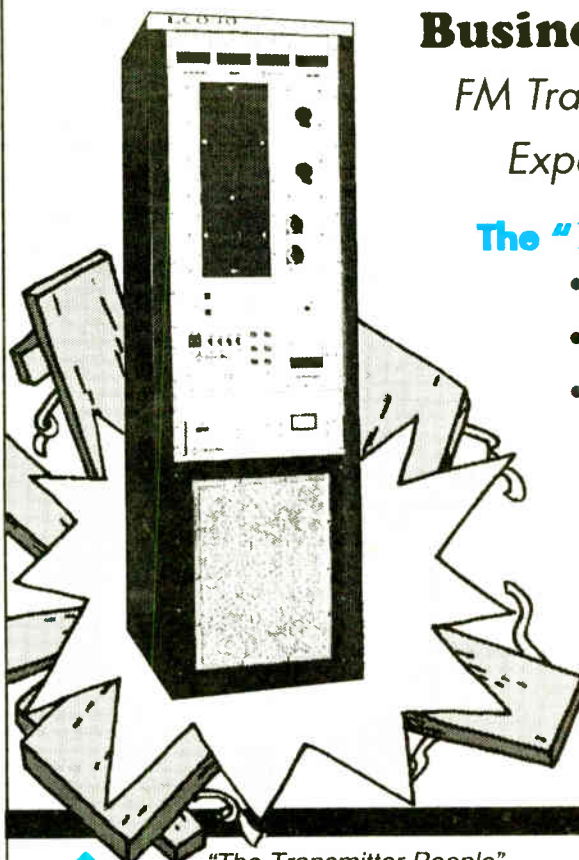

"The Transmitter People"  
**Energy-Onix**

752 Warren Street, Hudson NY 12534

**518-828-1690**  
**FAX: 518-828-8476**

Circle (21) On Reader Service Card

## TRANSCOM CORP.

Serving the Broadcast Industry Since 1978

Fine Used AM & FM Transmitters and Also New Equipment

For the best deals on Celwave products, Andrew cable and Shively antennas.

300 watt FM 1989 TTC 300J	1 kW AM 1974 Harris BC1H1
1 kW FM 1978 Collins 831C2	5 kW AM 1968 CCA AM5000D
2.5 kW FM 1978 CCA 2500R	5 kW AM 1979 Continental 315F
3 kW FM 1975 CCA 3000D	5 kW AM 1977 RCA BTA 5L
3 kW FM 1980 CSI 3000E	10 kW AM 1983 Harris BC10H
3 kW FM 1974 Harris FM3H	50kW AM 1986 Continental 317C-3 with spare parts
5 kW FM 1991 BE FM5B	50kW AM 1982 Harris MW50B with spare parts

1077 Rydal Road #101  
Rydal PA 19046

800-441-8454 • 215-884-0888 • FAX No. 215-884-0738

Circle (126) On Reader Service Card

**TRANSMITTERS...WTS**

Spare parts for CCA AM50,000D, incl. HV transformer, mod. transformer, mod. reactor, HV filter choke, tube sockets and more. Call Transcom Corporation 800-441-8454 or 215-884-0888.

McMartin AM/FM transmitter, any model, exciter or stereo modules. Goodrich Enterprises, 11435 Manderson, Omaha NE 68164. 402-493-1886.

4CX250B, 4-400, 833, 813, 5CX1500, 4-1000, all types, full wty EIMAC, Amperex, RCA. Westgate 800-213-4563.

RE-CONDITIONED TRANSMITTERS		
<b>FOR SALE</b>	<b>AM Transmitters</b>	
	50 kW 1978 MARCONI B6034	\$58,000
	10 kW 1970 MARCONI B6029	\$18,000
	10 kW 1980 PYE/TVT LDM 1235/02/01	\$24,000
	1 kW MARCONI, Various units	\$6,000
	<b>FM Transmitters</b>	
	10 kW 1986 PYE/TVT 1233/50/02	\$18,000
	1 kW 1970 MARCONI	\$6,000
	1 kW CTE, NEW	\$9,000
	<b>Shortwave Transmitters</b>	
50 kW 1970 MARCONI HF	\$52,000	



**CONTACT:**  
Ray Anderson  
East Anglian Productions  
Studio House, 21-23 Walton Road,  
Frinton-On-Sea, Essex. CO13 0AA. UK  
Tel: Country Code 44 (0)255 676252  
FAX: Country Code 44 (0)255 850528

- PART EXCHANGE WELCOME
- TRANSMITTER HIRE AVAILABLE
- MAJOR CREDIT CARDS ACCEPTED
- ALL PRICES QUOTED IN US DOLLARS

Transmitters supplied re-conditioned and tuned to your frequency. 3 month warranty for parts and labour, excluding tubes.

**\$\$\$ TRANSMITTERS FOR LESS \$\$\$**

1 KW AM Gates BC-1G	1 KW FM Collins 830D1
1 KW AM Gates Vanguard	1 KW FM Gates FM-1G
1 KW AM Collins 820D1	2.5 KW FM Collins 831D1
1 KW AM Harris SX-1A	5 KW FM Harris FM-5H
1 KW AM Gates BC-1F	5 KW FM RCA BTF-5D
1 KW AM RCA BTA-1D	10 KW FM Harris FM-10H2
5 KW AM Gates BC-5P2	10 KW FM RCA-BTF 10D
5 KW AM Harris BC-5H	20 KW FM RCA BTF-20E1
5 KW AM RCA BTA-5H	20 KW FM Harris FM-20H
10 KW AM Continental 316F	25 KW FM AEL 25-KG
10 KW AM RCA BTA-10H	
50 KW AM Continental 317C2	
50 KW AM Harris MW-50A	
50 KW AM RCA BTA-50H	

\*\*\*All transmitters are tuned and tested on your frequency  
\*\*\* See your transmitter working in our plant before you take it home

**ALSO CALL ARMSTRONG TRANSMITTER FOR:**

- Custom built shortwave transmitters from 1 to 100KW
- Hard to find parts and custom fabrication for any transmitter
- Rebuilt FM antennas tuned to your frequency
- Custom built antenna tuning units and phasers
- STL's, STL antennas and other microwave products
- New and used transmission line, connectors and accessories
- UHF and VHF TV transmitters, antennas and diplexers
- Field service and installation on any transmitter
- Complete turnkey service for any AM, FM and shortwave facility

**ARMSTRONG TRANSMITTER CORPORATION**

ARMSTRONG MAIN OFFICE 4835 North Street Road Marcellus, NY 13106 Tel: 315-673-1269 FAX: 315-673-9972	ARMSTRONG INTERNATIONAL 3100 N.W. 72nd Avenue Miami, FL 33122 Tel: 305-471-1175 FAX: 305-471-1182	*Hablo Español*
--	---	-----------------

**Want To Buy**

McMartin FM exciter. D Thompson, Bct Engr Consultants, 2740 Cherry Ln, Walnut Creek CA 94596. 510-933-4881.

Collins 310Z-2 Exciter, RF amp module, dead or alive. D Voy, KMAQ AM, 129 N Main St, Maquoketa IA 52060. 319-652-2426.

RCA BTF-10C & BTF-10D, would like to contact other users to share info on care & feeding, parts sources, finger stock, plate blocking capacitor, call to join users group, will share all information. D Payne, WZPL, 3500 DePauw Blvd Ste 1060, Indianapolis IN 46268. 317-879-9999.

RCA FM exciter, BE FX30 exciter, Bird wattmeters (2). B Lacy, KEMA FM, 3611 Soncy 6A, Amarillo TX 79121. 806-355-4554.

Harris MW1-A, PA modules, dead or alive. D Voy, KMAQ, 129 N Main, Maquoketa IA 52060. 319-652-2426.

Need 1 kW AM xmtr, prefer operational, RCA BTA-1, Gates BC-1, etc, will arrange shipping. G Goldsmith, POB 5786, Beverly Hills CA 90209. 310-696-0177.

**TUBES**

**Want To Sell**

Cleaning our unneeded tube inventory, about 50 small tubes and sev type 810 and 813 tubes, both new and used. J Mathis, WCSI, 3212 Washington St, Columbus IN 47203. 812-372-4448.

20 kW 50 dummy load, air cooled, 115 volt blower, flat to 30 MHz, \$2950 FOB NC. J.S. Belts Co, 704-526-5482.

**ECONCO**

Quality Rebuilt Tubes  
Approximately 1/2 the Cost of New

Call for Our Price List  
**800-532-6626**  
**916-662-7553**  
**FAX 916-666-7760**

Circle (150) On Reader Service Card



**Svetlana**  
ELECTRON DEVICES

**Quality Power Tubes**

3CX15,000A7	4CX1500A
3CX10,000A7	4CX350A
3CX3000A7	4CX350AC
3CX2500F7	4CX250B
3CX2500F3	4CX250BC
3CX2500A3	4CX250R
3CX2500H3	4X150A
YC130	5CX1500A
4CX15,000A	5CX1500B
4CX10,000D	811A
4CX5000A	813
4CX5000R	833A
4CX3500A	8560AS

- Watch this list grow.
- Manufactured in Russia's largest power tube factory.
- Generous warranty based on high quality.
- Honest prices based on quality at low cost.
- Shipment from USA stock.

**Broadcasters**  
Call: 205-882-1344  
FAX: 205-880-8077

**OEMs, Distributors, Volume Purchasers**  
Call: 415-233-0429  
FAX: 415-233-0439

Circle (66) On Reader Service Card

**Want To Buy**

**WANTED!**  
Transmitting Tubes

We BUY & SELL all types of transmitting/receiving tubes.

**C&N Electronics**  
Harold Bramstedt  
6104 Egg Lake Road  
Hugo, MN 55038

(612) 429-9397 ext.23  
(800) 421-9397 ext. 23  
FAX (612) 429-0292

Circle (18) On Reader Service Card

**TURNTABLES**

**Want To Sell**

Russco Cue Master (4), \$150 ea. J Kesler, WOBZ, POB 446, Livingston KY 40445. 606-843-22A 9999.

JVC 4-DD-5 quadrasonic disc demodulator, low hours, \$50. D Pulwers, Dave's Price Audio, 310 N Howard St, Alexandria VA 22304. 703-751-9346.

Technics SL 1200 MK2, w/Stanton cart, \$275; Sony SQD 2050, 4 chl dec decoder, \$30; turntable preamp, RIAA curve (2), \$20 ea. G Dunn, 5383 Willow Lake Ct, Byron CA 94514. 510-516-0299.

Audiometrics QEC TP84 preamp, \$250; SL-1200MK2 turntable system, like new, \$350. Kacæe Production Agency, POB 712, Luverne MN 56156. 507-283-4588.

Sparta w/stereo preamp equalizers (2), \$300 ea; Rek-O-Kut w/mono preamp equalizers (2), \$200 ea. P Bridger, KGKO, 202 E Cross, Benton AR 72015. 501-778-8257.

RTS-405 stereo preamp (2), used 6 mos, \$140 ea + shipping. B Lord, Lord Broadcasting, 13313 SE 208th St, Kent WA 98042. 206-631-2374.

Technics SP-15, excellent, \$350. R Robles (818) 996-7237.

Technics SH15B3 turntable base, new in box, \$250, plus shipping. Klay 801-272-1814.

**ADVERTISE!**

in Radio World's Broadcast Equipment Exchange  
For details, including rates & deadlines,  
call Simone at **1-800-336-3045**

## ADVERTISER INDEX

This listing is provided for the convenience of our readers. Radio World assumes no liability for inaccuracy.

Page No.	Advertiser	Reader Service No.	Page No.	Advertiser	Reader Service No.
14	360 Systems	120	18	Harris Allied Broadcast Equipm	39
9	AEV SNC	117	20	Harris Allied Broadcast Equipm	44
48	AIR Corp.	42	3	Hnat-Hindes	79
7	ATI	136	40	ITC Instruments	107
34	ATI	24	45	J Squared Technical Service	106
6	Arrakis	14	22	Korg	137
16	Arrakis	123	34	Logitek	35
39	Arrakis	205	48	M.I.C.S.	22
50	Arrakis	112	38	Mackie Design	184
45	Audio Broadcast Group	177	27	Man From Mars	173
51	Audiopak	51	57	Marathon	84
59	Audiotronics	195	48	Martin Leasing	155
34	Autogram	139	33	Micro Technology Unlimited	157
18	Belar	34	47	Modulation Sciences	174
25	Benchmark Media Systems	187	32	Moseley	191
49	Bext	133	10	NSN	193
45	Broadcast Devices Inc.	134	41	National Public Radio	91
4	Burk Technology	93	24	Neumann USA/Sennheiser	118
1	CCA	72	11	Orban/AKG/Obx	146
58	C & N Electronics	18	19	Pacific Recorders	87
42	CRL	80	45	Phasetek	89
48	Artran/Celcast	156	48	Pike & Fischer	200
34	Circuits Werkes	70	48	Pristine Systems	199
8	Clark Wire & Cable	165	40	Prophet Systems	32
8	Clark Wire & Cable	127	35	QEI	189
45	Comet North America	204	46	Radio Programming & Management	169
34	Comrex	1	2	Register Data Systems	77
40	Continental Electronics Corp.	28	34	SSAC Company	4
17	Coriana	170	40	Satellite Systems	167
18	Cutting Edge	76	40	Shively Labs	20
21	Dataworld	61	37	Shure Brothers	143
53	Dataworld	219	28	Speaker Kits	128
29	Delta Electronics	64	13	Svetlana Electron Devices	99
12	Denon America	171	58	Svetlana Electron Devices	66
45	Dolby	85	23	Symetrix	138
58	Econco	148	3031	TM Century	215
13	Econco	150	15	Tascam	163
57	Electronic Repair	43	36	Tectan	209
45	Energy-Onix	21	43	Telos Systems	174
27	Excalibur	180	34	The Blue Group	208
25	Ghostwriters	149	40	The Management	212
26	Gorman Redlich	115	57	Transcom Corp.	126
48	HHB Communications Ltd.	103	53	USAFoam	63
45	Halland Broadcast	202	40	Valley Audio Group	104
44	Hallikainen & Friends	135	60	Wheatstone	181
	Harris Allied	147	40	Zephyrus Electronics	86

Publisher .....Stevan B. Dana  
Associate Publisher .....Carmel King  
Marketing Consultant .....Al Leon  
Marketing Assistant .....Annette Deutscher  
Production Director .....Kim Lowe  
Production Manager .....Julianne Stone

Production .....Vicky Baron, Lisa Lyons, Lisa Mamo  
Ad Coordinator .....Kathy Jackson  
Ad Coordination Manager .....Simone Mullins  
Circulation Director .....Rebecca Seaborg  
Accounts Receivable .....Steve Berto

**Advertising Sales Representatives**

U.S. East: Skip Tash .....703-998-7600 Fax: 703-998-2966  
U.S. West: Dale Tucker .....916-721-3410 Fax: 916-729-0810  
International: Stevan B. Dana .....+1-703-998-7600 Fax: +1-703-998-2966  
Europe: Dario Calabrese .....+39-2-753-0274 Fax: +39-2-753-2697  
Japan: Eiji Yoshikawa .....+81-3-3327-2688 Fax: +81-3-3327-3010

Free Subscriptions are available upon request to professional broadcasting and audiovisual equipment users. For address changes, send current and new address to RW a month in advance at P.O. Box 1214, Falls Church, VA 22041. Unsolicited manuscripts are welcomed for review; send to the attention of the appropriate editor.

**ACTION-GRAM**

**Equipment Listings**

Radio World's Broadcast Equipment Exchange provides a FREE listing service for radio stations and recording studios only. All other end users will be charged. Simply send your listings to us, following the example below. Please indicate in which category you would like your listing to appear. Mail your listings to the address below. Thank you.

Please print and include all information:

Contact Name \_\_\_\_\_  
Title \_\_\_\_\_  
Company/Station \_\_\_\_\_  
Address \_\_\_\_\_  
City/State \_\_\_\_\_  
Zip Code \_\_\_\_\_  
Telephone \_\_\_\_\_

I would like to receive or continue receiving Radio World FREE each month.  
 Yes  No

Signature \_\_\_\_\_ Date \_\_\_\_\_

Please Circle only one entry for each category:

**I. Type of Firm**

D. Combination AM/FM station	F. Recording studio
A. Commercial AM station	G. TV station/teleprod facility
B. Commercial FM station	H. Consultant/ind engineer
C. Educational FM station	I. Mfg. distributor or dealer
E. Network/group owner	J. Other _____

**II. Job Function**

A. Ownership	G. Sales Manager
B. General management	E. News operations
C. Engineering	F. Other (specify) _____
D. Programming/production	

Brokers, dealers, manufacturers and other organizations who are not legitimate end users can participate in the Broadcast Equipment Exchange on a paid basis. Line ad listings & display advertising are available on a per word or per inch basis.

WTS  WTB  Category: \_\_\_\_\_  
Make: \_\_\_\_\_ Model: \_\_\_\_\_  
Brief Description: \_\_\_\_\_  
Price: \_\_\_\_\_

\*Closing for listings is every other Friday. Please be aware that it does take approximately 1 month for your listings to appear. They will then appear for only 2 issues. If more time is needed, please re-submit your listings.

**Broadcast Equipment Exchange**  
Phone: 703-998-7600 PO Box 1214, Falls Church, VA USA 22041 FAX: 703-998-2966

# AIRMASTER 90

Starting at  
**\$6295**

**Very  
Affordable.  
Very  
Reliable.**



*The Sound Of Perfection*

**AUDITRONICS**

3750 Old Getwell Road, Memphis, TN 38118  
901-362-1350, FAX: 901-365-8629

Circle (195) On Reader Service Card

The new AirMaster 90 specifications are compatible with digital technology. It uses superior thick-film hybrids. The AirMaster 90 has a user-programmable logic control system that utilizes a PIC microprocessor. Faders control precise stereo-balanced VCA's and push buttons are electronic with LED status indicators.

The AirMaster 90 has a TWO YEAR WARRANTY . . . after all, it has the highest possible reliability in the industry.

# Every City Has One.

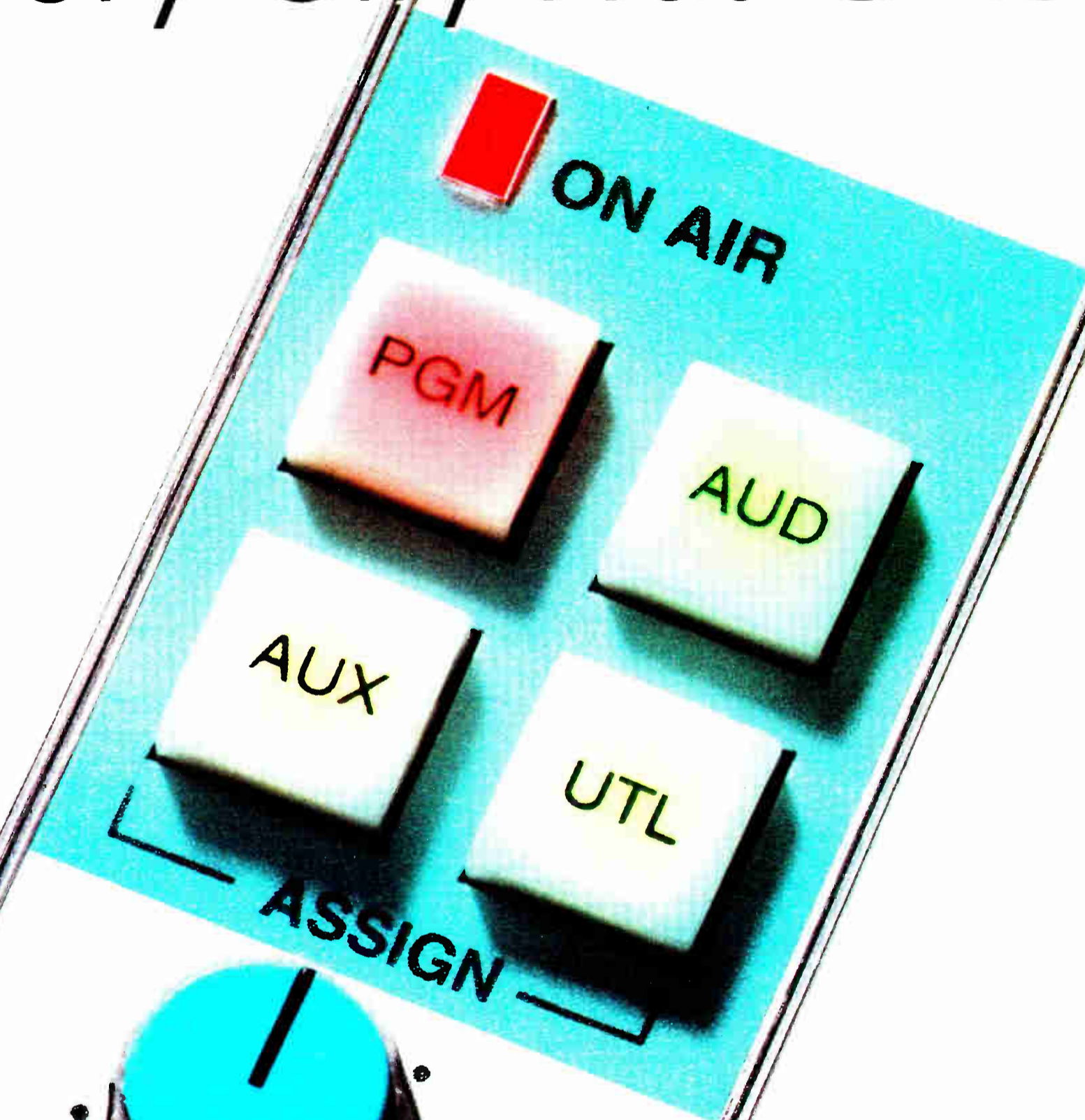

**A Number One Station.**

The A-6000 On-Air Console is for you.

 **Wheatstone<sup>®</sup> Corporation**

7305 Performance Drive, Syracuse, NY. 13212  
(tel 315-452-5000 / fax 315-452-0160)

Circle (181) On Reader Service Card

World Radio History