JGG3776 D08 \$704 \$873 071
BARRY MICHKIND
CE
KXEW
2033 AUGUSTA PL
TUCSON AZ 05710

STL Deadline
Extended
see story page 2

Radio World

Vol 14, No 3

Radio's Best Read Newspaper

February 7, 1990

RF Bulb Effort May Hurt AM

by Alan Carter

Washington DC Efforts by utility companies to encourage commercial and residential use of energy efficient fluorescent light bulbs, which can produce radio frequency interference (RFI) of AM reception, may cause the FCC to re-examine its lighting device standards.

The RF lamps were the subject of an extensive proceeding from 1983 to 1987 that ended in no change to FCC standards, much to the frustration of some broadcasters. But several broadcast engineers with key AM station groups said new campaigns promoting fluorescent bulbs may warrant a renewed investigation.

Susquehanna Radio Corp. Engineering VP Charlie Morgan said that before the bulbs are used widespread, there should be further studies into RFI. "The key is if we have a number of them in a home, we have trouble."

A similar program for commercial users is underway by Potomac Electric Power Co. in the Maryland suburbs of Washington DC.

The program in use by Massachusetts Electric also is in place at its sister utility companies, Narragansett Electric and Granite State Electric. The customer base affected is 1.3 million in Massachusetts, Rhode Island and New Hampshire.

A spokesman for New England Power Service Co., parent company of Massachusetts, Narragansett and Granite State utilities, said any products used

(continued on page 10)



The Winter CES featured the latest in high-tech wizardry.

DAT and CDs Are Hot at Winter CES

by John Gatski

Las Vegas NV Besides headline-stealing car CD and DAT players, other products such as digital processor receivers, recordable CDs and anti-tape copying DAT recorder prototypes were previewed at the Winter Consumer Electronics Show.

Buyers flocked to the car receiver company displays to look over the DAT decks and the CD shuttle systems that allow multi-play and easy removal of the units to prevent theft.

But other hot products on display during the January show which also garnered a lot of attention include advanced diversity style reception, programmable station finders and better tuners.

A frequent topic of conversation piece was the Technics CQ-ID90 tuner/deck with ID Logic, a technology that allows the tuner to automatically select a programmed format station while driving anywhere in the US.

The driver simply has to push one of the six format buttons (classical,

C&W, rock, jazz, easy listening and talk) in any area, according to Technics and the radio will digitally list the stations in that area which offer the selected format.

The technology is based on a 2-megabit ROM and microprocessor that contains all US AM and FM stations over 1 kW, which amounts to 4500 AM and 4900 FM stations.

Advanced diversity

Another interesting bit of technology was the Blaupunkt Auto Directional Antenna, which operates similar to diversity reception via four antennas electronically configured in a "phase array" within the bumpers.

"The antenna goes several steps beyond diversity," said Blaupunkt Public Relations Spokesman Gordon Sell.

The Auto Directional Antenna provides up to 6-8 dB of directional gain in the direction of the stronger station signal while blocking out weaker signals that cause interference and multipath, according to Sell.

Blaupunkt also demonstrated its

(continued on page 11)

New push for RF lights

The extent of the use of the energy efficient lamps was underscored in an ABC World News Tonight with Peter Jennings report focusing on Massachusetts Electric. As part of the overall energy conservation program, the utility company will install the bulbs free of charge.

FCC Faces High Court

by Charles Taylor

Washington DC The Supreme Court will hear two cases this spring that will examine the constitutionality of FCC policies giving preference to minority-owned businesses seeking broadcast licenses.

State and local government guidelines already have been established, after the court ruled last January that the Constitution limits the adoption of programs giving preference to minority- and women-owned businesses in government programs.

But federal guidelines remain cloudy and when the cases come to the high court, probably in April, decisions made regarding FCC minority policies likely will set national precedence for other agencies as well.

No occasion for federal view

"So far the courts have had occasion to look at what state and local governmental bodies can do, but it has not had occasion to look at how far the federal government can go with what we'll refer to as race-based governmental

(continued on page 3)

Q.
A.

How Many DYNAMAX CTR10 Series cartridge machines are in use worldwide?
Over 7,000 units now are operating in 33 countries. And that's less than four years since introduction of the CTR10 Series.

Find out why the DYNAMAX CTR10 Series has proven #1 in popularity around the world. Contact your authorized Dealer or Fidelipac for more information.



Fidelipac Corporation, P.O. Box 808, Morristown, NJ 08057 U.S.A.
609-235-3900 FAX 609-235-7733 TELEX 710-897-0254
Dynamax is a registered trademark of Fidelipac Corporation.

Circle 29 On Reader Service Card

FCC Extends STL July Deadline

by John Gatski

Washington DC Bowing to pressure from engineers concerned about the approaching STL type notification deadline, the FCC has decided to extend the deadline three years, from 1 July 1990 to 1 July 1993.

Although the FCC staff indicated last fall it would not extend the deadline, Mass Media Chief Roy Stewart said in a Commission announcement

issued 18 January that subsequent information provided by the Society of Broadcast Engineers (SBE), National Public Radio (NPR) and broadcasters' letters prompted the change.

NPR told the Commission that 70% of public stations use STLs with many using two—one as a back-up.

According to the FCC, NPR estimated that it would cost each station \$4573 to bring STLs into compliance, a burden that may be impossible by 1 July.

Stewart said the Commission also has received numerous letters from broadcasters supporting an extension or permanent "grandfathering" for STLs made before 1985.

In 1985, the Commission decided to require STLs to meet the type notification specification within five years because of an anticipated crowding in the 944-952 MHz band.

Stewart noted that an extension was granted, in part, be-

cause the expected congestion was overestimated. He also noted that stations have only

concern over the deadline is "due to their lack of planning," he said in the announcement.

...extension was granted, in part, because the expected congestion was overestimated.

recently begun evaluating the costs of type notifying STLs. Much of the broadcasters'

The deadline extension comes despite STL manufacturers' efforts to test and type notify some older models that meet the FCC specifications and offer upgrades for those that do not in order to meet the original 1990 deadline.

In addition, STLs manufactured after the FCC's 1985 Report and Order do meet type notification deadlines.

The Commission emphasized that the extension "should not be interpreted as modifying our intent to require licensees to use more spectrum-efficient bandwidths in congested areas where there is a need to accommodate new STLs."

The Commission also noted that "we wish to emphasize that while we will grant the requested delay, all existing STL/ICR equipment must comply with the current technical standards and must be notified by July 1, 1993 if it is intended to be used after that date."

For information from the FCC, contact Jim McNally at 202-632-9660.

We Re-invented the Wheel AND IT'S SQUARE!

Naturally, with all of Wheatstone's experience at building and interfacing consoles, it was inevitable that we would take on the design and manufacture of suitable furniture for our audio installations. First we listened to engineers and their requests, then we went to work. The result is a significant improvement over previous designs.

Consider the advantages of double-sided equipment cabinets with fully interchangeable door panels, with each side able to accommodate 19 inches of rackmount equipment. Consider the convenience of hinged twin drop-down punchblock panels for easy installation and maintenance. Consider the advantage of hard chrome plated steel mounting rails that eliminate the stripping problems associated with lesser aluminum designs. Simply consider the strength we've achieved with full inch and a half thick side panels and hybrid inch and a half thick countertops.

We have re-invented cabinet technology. We've wedded the latest precision NC metal componentry to hybrid plywood high density, high resin pressure-laminated substrates. Our construction and bonding techniques have been optimized to eliminate stress related laminate problems. We've handled wire management: there are generous pathways between each enclosure, as well as an integral channel punchblock housing under the console counter to keep everything neat, concealed and away from unauthorized hands. And, since cabinet faces can accept either equipment or door panels, systems can easily be configured to fit virtually any room. Doors can even be placed on cabinets intended for future electronics installation.

This cabinetry is very clever, unbelievably strong, and (of course) square--precisely. It has that Wheatstone major market look. So contact Wheatstone for furniture, consoles, or prewires.



Wheatstone Corporation

6780 V.I.P. Parkway, Springfield, MA 01111

Tel 315-455-7740 FAX 315-454-8104

INDEX

Berlin Wall a Barrier No More	by Dee McVicker	15
Doing Radio the Cowboy Way	by Henry Fennell	17
Techniques for Stereo Miking	by Bruce Bartlett	21
Avoid Fines by DCO Log Review	by Harold Hallikainen	22
An Introduction to Construction	by Frank Miller	26
College Radio and Commercial Origins	by George Riggins	28
How to Hot Rod a Processor	by John Shepler	31
A "Holistic" Digital Perspective	by Mel Lambert	32
The Basics of Binary Counting	by Ed Montgomery	36

Court Eyes FCC Minority Policies

(continued from page 1)

policies," said Harry Cole, a partner with Bechter & Cole in Washington, which will represent one of the involved parties in court.

"The review of the two cases will give the court the opportunity to consider the question and issue at least some general guidelines that would be applicable to the FCC, all other federal agencies and ultimately, the Congress," he said.

Specifically, the Supreme Court will examine Commission policies that allow distress sales of broadcast licenses to minority-owned companies and those that give preference to minority- and women-owned companies in comparative hearings for new licenses.

Distress sale unconstitutional

The first case to be judged by the high court was ruled upon last April by a Washington federal appeals court and judged the FCC's distress sale policy unconstitutional.

The decision was based on the FCC's initial award of a license in a distress sale to Astroline Communications, a partnership controlled by minority interest Richard Ramirez. The appeals court ruled, however, that the license should go to computer consultant Alan Shurberg, who had been trying to get a TV license in Hartford, CN since

1982.

Astroline, in turn, appealed to the Supreme Court.

The second case upheld the constitutionality of an FCC policy giving minority and women applicants some preference in awarding new licenses.

In an appeal ruling, a broadcast license in Orlando, FL was awarded to the Hispanic-owned Rainbow Broadcasting Co.

"The bottom line is that there is a reasonable and likely potential that the court is going to throw out the Commission's policies. . ."

Metro Broadcasting, a competitor, appealed the decision with the Supreme Court.

Renounce minority favoritism

Cole, who represents Shurberg Broadcasting in the first case, believes the court will lean toward reforming policies that renounce favoritism toward minorities and women.

"The bottom line is that there is a reasonable and likely potential that the court is going to throw out the Commission's policies, at least the two that are

before the court—comparative preferences and distress sales," Cole said.

"If you drop back and look at it not just from the narrower FCC perspective but from the overall perspective of Constitutional law, what the Supreme Court has done in recent years in looking at affirmative action as reverse discrimination has narrowed considerably regarding what governmental bodies can do," he added.

However, James Winston, executive

row it," Winston said.

He added that if the court were to rule distress ownership unconstitutional, it will not have that much effect, noting there have been only four such cases in the last nine years. Ruling against the comparative hearing preference would be more serious, he said, although he expects the policy to stand true.

The FCC and the Justice Department both have filed comments with the Supreme Court urging it to turn down the appeals. The organizations said that the court did not need to explore the issue because Congress is scheduled to reconsider Commission policies later this year when it passes its appropriations bills.

A ruling is expected in late spring.

In a related matter, the Supreme Court rejected a request to reconsider the FCC's Fairness Doctrine, which was eradicated in 1987. A New York peace advocacy group claimed it deserved equal time to contest advertisements in favor of a nuclear power plant.

NAB and the Reporters Committee for Freedom of the Press opposed the request to reinstate the doctrine.

For information on the minority preference cases before the Supreme Court, contact Harry Cole at 202-833-4190 or NABOB at 202-463-8970.

1990.

Time to go Digital.

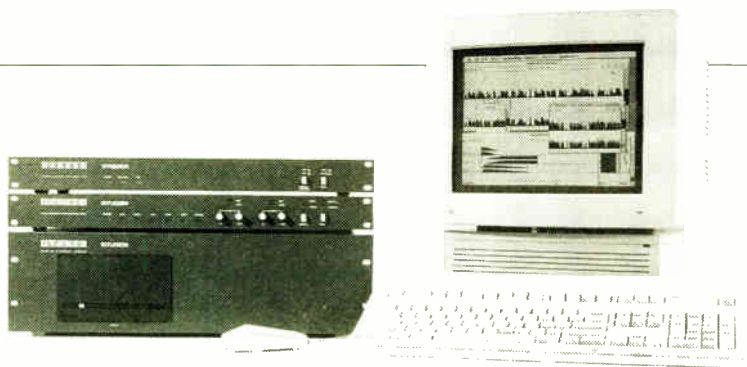

Dyaxis is the digital future of audio, and Bradley can put it into your hands today. This advanced digital recording and editing system is surprisingly affordable. Call your Bradley professional, and have him put the power of Dyaxis to work for you.

Bradley

BROADCAST

8101 CESSNA AVENUE • GAITHERSBURG, MARYLAND 20879
TOLL FREE: 800-732-7665 • MD & DC: 301-948-0650 • FAX: 301-330-7198

Where Service and Engineering Make the Difference

Circle 3 On Reader Service Card

World Radio History

PHASE TRAK 90™

The perfect cart machines for an imperfect world.

PHASE TRAK 90
STEREO PLAYBACK
(WITH TIMER) \$2650**
STEREO RECORD/PLAYBACK \$4295**

With phase error, tape spec fluctuations and harried DJs, a cart machine's working environment is far from perfect. That's why you need Phase Trak 90: There's never been a better cart machine for the real world of radio.

- Continuous non-encoded phase correction circuitry* actually cleans up carts that sound dull on ordinary machines—no re-recording necessary.
- Automatic Tape Analysis system with Learn Mode gets the best performance from every tape formulation.
- Lockout functions eliminate on-air mistakes like yanking a cart before it's cued or forgetting to remove it after it's played.
- Robust, fully modular plug-in construction takes everything a DJ can dish out.

Phase Trak 90: Quite simply, the best cart machine ever made. Call Bob Arnold at (217) 224-9600, or ask your Broadcast Electronics distributor for complete information.

* Patent Pending

** F.O.B. Quincy, IL: Exclusive of sales or use tax

BE BROADCAST ELECTRONICS INC

4100 North 24th Street • P.O. Box 3606 • Quincy, IL 62305
Tel: (217) 224-9600 • Fax: (217) 224-9607 • Tlx: 250142

Circle 45 On Reader Service Card

DAT in Las Vegas: Play It Again

by Judith Gross

Falls Church VA Is this the year that DAT finally lives up to its hype?

Out at the winter CES in Las Vegas—city of sin—there was evidence that it is



Fun and games at the CES

on its way, once the anti-copy legislation gets through Congress.

Meanwhile, the recordable CD is finally a reality, at least it was shown at



the show. So now the debate is, will DAT ever get its chance to capture a fair share of the pro and consumer market?

I know a lot of stations who said they'd wait for the recordable CDs. But logic seems to tell ya that if there's room in the world of audio for vinyl and analog tape, there ought to be a place for DAT.

OK, maybe not the primary source, but two hours on a tape is a lot of listening/play time.

Meanwhile I hear some stations which went all DAT are mixing media more and more these days. Then there are

those who hyped CDs and ended up carting the music anyway. 'Course a lot of those folks were using the el-cheapo brand of consumer CD players.

But one thing's for certain (as I said last time): carts keep on hanging in there.

Out on the cart sales front, comes a bit of news from **Broadcast Supply West**. Seems the company has discontinued its cart reloading service.

Tim Schwieger, VP of marketing, says the process is a precision one, and it got tougher and tougher to find that labor force who could do a good job and keep the cost low. But he says new cartridge sales are booming. Stay tuned, we'll give



Sir Battison and Sir Hallinan

you more details next issue.

Also at the winter show, by the by, was that nifty personal Walkman-styled radio from **Sangean** that has both FM stereo and (drum roll please) **AM stereo**. Yes.

Told you several columns back about it, after I saw it at the SBE national convention. Well, **Steve Kravitz's** company, **Rradco** (two Rs) is handling them for the broadcast market. You'll finally be able to hear your AM station in stereo, and it sounds good. Also it won't cost you an arm and a leg.

Hey, even over at the NAB they procured a couple of these models, and that's even with their own "ultimate" radio sitting there in the lab. So, if you're interested in getting one of these **AM and FM stereo** models from Steve, call him at 708-576-0554.

And look at that, they went and changed the area code for the Chicago suburbs to 708 and nobody told me!

And speaking of the CES, it wasn't all work (it never is in Las Vegas). Over at the newly-opened **Mirage**, some furry felines frolicked in a sumptuous pool. Yes, they're tigers. And yes, they're the rare white variety. So if you'd rather view the wildlife than gamble ... but then

again, the NAB spring show is in Atlanta this year. (Gee, maybe we can persuade the Peachtree folks to bring in the big game and the one-armed bandits. Hmmm.)

Also speaking of the SBE, there was quite a turnout for an elegant luncheon in DC in mid-January. The occasion was two-fold. One: the SBE board was having its January meeting. And two: an

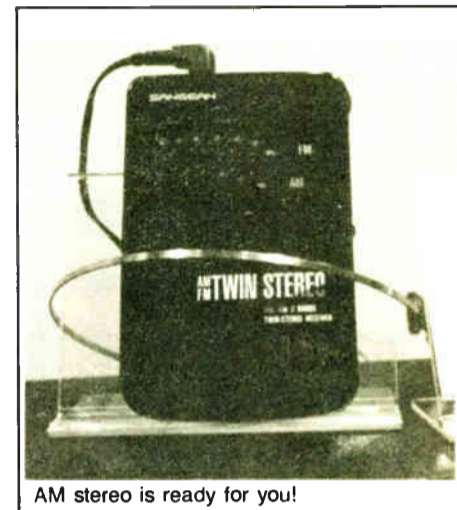

AM stereo is ready for you!

award was given to my old buddy from Binghamton, **Charlie Hallinan**.

Charlie was the one who started the whole SBE thing, with **Chapter #1** in the little upstate town I used to call home. He was the "retired" CE of **WKOP**, the country station (it's now all oldies with different calls). I use the term "retired" loosely, because CEs came and went while I was at **WKOP**, but Charlie was always around to **bail the station out** in a crisis.

Anyway, the SBE's gentlemanly **John Battison** gave Charlie the much-deserved honor.

As we all know, long-time CEs never retire, they just become consultants. Where would we be without them?

Heard a juicy tidbit? Spill your guts to **Earwaves** by faxing JG at 703-998-2966, writing to **PO Box 1214, Falls Church VA 22041**, or calling 703-998-7600. Who knows, you could win a coveted **RW mug**.

Two Transmitter Sites?

Lee Waller says "no problem" with Burk

WBPM delivers CHR programming 24 hours a day to Kingston, New York and the greater Hudson valley. Chief Engineer Lee Waller knows what it takes to keep the signal on the air all the time.

Their commitment to reliability starts with two transmitter sites, both controlled by one Burk Technology ARC-16 Remote Control System.

BURK
TECHNOLOGY

"My favorite feature," says Lee, "is the ability to operate any function at any site from anywhere in the system. I do my routine maintenance at the auxiliary site, then drive to the main site, switching between sites without having to bother the jock."

A reliable remote control system is a must for WBPM. A trip to the transmitter means a grueling mountain climb, four-wheeling along a creek bed to the top.

Lee's ARC-16 might save him a few trips.



ARC-16 Remote Control System

You don't have to have two sites to take advantage of the convenience and reliability of a Burk Technology Remote Control. Our systems are backed by a 2-year warranty and the best service in the industry.

Want to know more about how Lee solved his problem? Call us **TOLL FREE** at

1-800 255-8090.

Burk Technology, Inc.
7 Lomar Drive
Pepperell, MA 01463
(508) 433-8877

READERS FORUM

If you have comments for *Radio World*, call us at 800-336-3045 or send a letter to Readers' Forum (Radio World, Box 1214, Falls Church VA 22041 or MCI Mailbox #302-7776). All letters received become the property of Radio World, to be used at our discretion and as space permits.

More help for AM

Dear RW:

In light of the announced FCC special hearing about the problems of AM and consideration of solutions, I'd like to "throw my hat in the ring" and propose a few solutions of my own.

1. Bring back the three year rule. Since this was eliminated, profiteering has become the byword of broadcasting. AMs in this day and age simply cannot generate the kinds of profits necessary to service huge debt without simulcasting or automating. This has led to a drastic cutback in services offered on the AM band and a lowering of quality programming all around as costs are cut in news and programming areas.

2. Eliminate simulcasting. How in the world is a community served by having the same station on the AM and FM band? Either program the station independently, or sign it off. Through simulcasting the AM is nothing more than an ad for the FM band and provides no unique reason to listen. If the station cannot stand on its own, eliminate it!

3. Clean up the AM band. As stations go dark or go bankrupt, eliminate the frequency from the market forever. This will help "clear the air" and get the band a reprieve from clutter.

Again, if the station cannot make a go of it, get rid of it. If someone has a way to save it, let them do it only if they can show an actual need for the station in the market.

4. Require *all* receivers to be stereo on *both* bands. This is something I proposed before the Commission panel some years back in Dallas at the Radio Convention. Waiting for the market to demand it is ridiculous. Remember, consumers have stereo on FM already. They don't *need* it on AM and will not pay extra to get it. Let the manufacturers decide which system they will incorporate into their units.

These suggestions will not immediately solve AMs problems. There is no "quick fix." However, with the implementation of these four ideas, the FCC can take a giant step in the right direction. Add in the new anti-skywave antenna designs and the NRSC 1 & 2 and AM can at least have a fighting chance. Then the programmers can "do their stuff" and get the listeners to at least consider an alternative band ... AM!

Keith Harris, Programming Manager
WASK-AM
Lafayette, IN

No band-jamming

Dear RW:

In reference to a letter in your *Readers Forum* of 13 December, I wish to comment. There was a complaint about the 700 mile protected status for clear channel AM stations with the author believing that low-powered stations should be able to operate within the radius.

I have been employed in the AM broadcasting industry for over a dozen years. During that time, I have noted the AM regional channels each year coming closer to resembling Class IV "graveyard channels" as the years roll on. Not everyone is able to live in an AM radio multi-service market, because of directional arrays and legal interference.

AM radio has the good news, bad news situation called skywave. To add to the bedlam and distant listener's jamming, would be to allow low to medium powered AM transmitters in a clear channel AM station's 700 mile radius.

The physics of AM broadcasting are such that it takes a 20 dB co-channel AM signal to capture a channel and squelch another AM station. In the case of FM broadcasting, it takes a 3 dB co-channel FM signal to capture a channel and squelch another FM station.

Which is to say, much more damage to listener reception is caused by co-channel AM broadcasting, regardless of power, thanks to nighttime skywave, than would be caused in the FM band. My solution to this problem would be to have the daytime AM stations legalized to have Class D type FM transmissions in the FM commercial band for local listeners when possible.

I believe it to be self-destructive to AM broadcasting for the service to con-

The recent campaign by a number of regional utility companies to persuade residents and businesses to use lights that emit RF is a disturbing one for those concerned about the future of AM.

While it is understandable that these firms would want to benefit from the energy-saving characteristics of these lightbulbs, the trend has developed with little or no concern about the effects on AM radios.

In the past NAB and other industry groups have tried to get the FCC to address the issue of manmade interference posed by these devices—but to no avail.

Although the issue was raised in the recent *en banc* Commission meeting on AM's problems, there is little hard data available on the extent of the problem RF lights pose.

A Second Look At RF Lights

One study which was done showed that when listeners experience such interference, they rarely notify the station or the utility, but simply switch to another station or stop listening.

Data on how much of a threat RF lights pose to the AM band are needed, as well as reports as to how widespread the trend is toward promoting their use.

Since the problem affects both stations and receivers, this is an issue where broadcasters and consumer electronics companies can join together to the benefit of both.

The EIA, the NAB and groups such as the NRSC can be the most effective in gathering the evidence that would convince the FCC it's time to act.

At the very least, those concerned about AM could urge some sort of warning on the package for those who may not want to give up listening to their favorite AM station.

At best, the data could be used to convince the FCC that greater protection for AM signals is warranted.

Acting swiftly and with strong facts to back up their concerns, the industry should get the FCC to take another look at the problem and prevent this form of RFI from becoming another nail in AM's coffin.

—RW

tinue degenerating into mutual jamming of fellow broadcasters. It is a national political problem when the jamming comes from Cuba and Central America.

I do not want to see our government endorse more legalized US standard broadcast band jamming as things are now out of hand, in my opinion. Everybody loses when the public is not served.

R. D. Erickson

Free-lance Broadcast Technician
Shenandoah, IA

Engineer shortage

Dear RW:

Articles have appeared recently in *RW* and other publications about the shortage of new talent entering the radio broadcast engineering field. These articles indicated that the primary reason for this shortage was the fact that new technicians were entering other fields such as manufacturing because of a higher salary scale. While this may be true there are several other reasons for this shortage of broadcast engineers.

In the past, engineers entered the field from two main areas, the military and amateur radio. Today, neither of these areas provide the training or experience for broadcast engineering. The military maintenance person is usually restricted to changing cards while the new amateur radio operator no longer builds or repairs his equipment. Also, the technical training schools are teaching digital theory while ignoring analog. The graduate student may be able to troubleshoot a computer but would not possess the knowledge to repair a 20 year old transmitter or console.

On the other side of the picture, many stations are not utilizing the skills and knowledge of older broadcast en-

gineers. While the stations all claim to be Equal Opportunity Employers, they will in fact discriminate against many highly qualified applicants such as older citizens. In my own case, I was passed over for many engineering jobs when the selecting officials found out that I was 60 years old. They were no longer interested in the fact that I had 40 years of experience in telecommunications—18 years of this experience was in AM/FM/TV engineering—and had several college degrees. When I was able to obtain reasons from the hiring officials for my non-selection, I received such answers as over-qualified (whatever that means), did not meet the selection factors (none would tell me what these factors were) or was not qualified in digital maintenance (they did not have any digital equipment). In my opinion, they came up with these reasons because it was not legal to tell me that I was not hired because of my age. I was fortunate to be hired by a General Manager that made his selection on the basis of qualifications and not age.

In summary, I do not believe that there would be a shortage of broadcast engineers at many locations if management would utilize the available talents. In most communities there are one or more semi-retired electronic technicians that would be glad to perform station maintenance. It appears to me that most 30 year old General Managers or Directors of Engineering believe that a person over 40 is no longer useful; however, there are many of us that would rather work than end up in a rocking chair. Any comments from hiring officials and older broadcast engineers on this matter?

Earl W. Hocker
KTAN/KFFN
Sierra Vista, AZ

Radio World

Vol 14, No 3 February 7, 1990

Editor, Judith Gross

Associate Editor, Alex Zavistovich

Buyers Guide Editor, Richard Farrell

News Editor, Alan Carter

Reporters, Charles Taylor, John Gatski

Benn Kobb, Frank Beacham/L.A.

Technical Advisor, Tom McGinley

Production Director, Judith Chamberlain

Production Manager, Kim Lowe

Jeanne Pearson, James Gillgam,

Bill Spencer

Publisher, Stevan B. Dana

Associate Publisher, Arthur Constantine

Ad Coordination Manager, Simone Leaser

Circulation Manager, Tiana Hickman

Accounts Receivable, Caroline Freeland

Advertising Sales Representatives:

East Coast, Art Constantine
800-336-3045, Fax: 703-998-2966

Midwest, Mike Dahle
914-762-3572, Fax: 914-762-3107

West Coast, Pat Macsata
415-786-2198, Fax: 415-786-2754



Radio World (ISSN: 0274-8541) is published semimonthly (except February, which has 3 issues) by Industrial Marketing Advisory Services, Inc., 5827 Columbia Pike, Suite 310, Falls Church, VA 22041. Phone: 703-998-7600, Fax: 703-998-2966. Second-class postage rates is paid at Falls Church VA 22041 and additional mailing offices. POSTMASTER: Send 3579 forms and address changes to Radio World, P.O. Box 1214, Falls Church VA 22041. Copyright 1990 by Industrial Marketing Advisory Services, Inc. All rights reserved.

Free subscriptions are available upon request to professional broadcasting and audiovisual equipment users. For address changes, send current and new address to RW a month in advance of the above address. Unsolicited manuscripts are welcomed for review; send to the attention of the appropriate editor.

Next Issue RW
Feb. 21, 1990

**GET IT
RIGHT**
GET IT FROM **ALLIED**

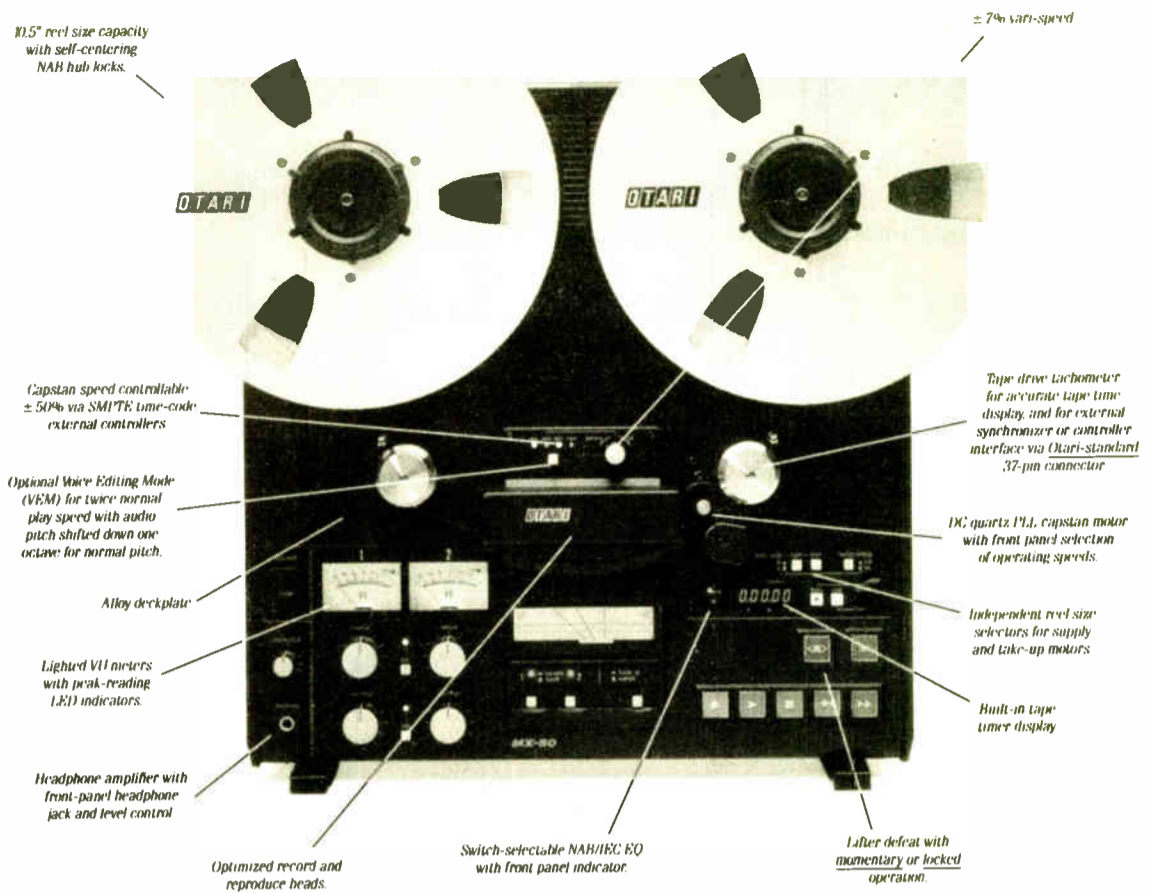

Industry Standards

OTARI

From the B11 to the full-featured MX-55 and the amazingly affordable MX-50, Otari two-tracks have become industry standards. The MX-50 shows a few of the reasons why.

ALLIED

Allied sets the industry standards for customer service and support, with innovative programs like these:

- Two Authorized Service Centers
- Used Equipment Exchange

- Systems planning, design, installation
- Satellite information and equipment
- Fully trained and knowledgeable sales people

YOU

You set high standards for yourself — count on Allied and Otari to help you meet them.

ALLIED
BROADCAST EQUIPMENT
— A HARRIS COMPANY —

800-622-0022

CANADA 800-268-6817

STUDIO EQUIPMENT • HARRIS RF PRODUCTS • SATELLITE GEAR • TRADE-INS • TURNKEY SYSTEMS

AM Tests "Noise Free Radio"

by Paul Rebmann

Tampa FL One local AM is ready to begin broadcasting "Noise Free Radio"—a system which uses FM on the AM band.

WQYK-AM has applied to the FCC for

of Noise Free Radio. He presented NFR in a paper and demonstration at the 1989 SBE convention. He also will conduct a NFR demonstration at the February meeting of the Michigan Association of Broadcasters in Lansing.

For the WQYK tests, Yazell explained,

ing in an 8.08 MHz signal with a deviation of 8 kHz. Dividing by eight will result in the 1010 kHz carrier with a 1 kHz maximum deviation. This will be connected to the transmitter in the same manner as the C-QUAM stereo signal. The transmitter then will amplitude modulate the signal normally.

The preliminary lab tests indicated that at least 90% amplitude modulation should be possible without degrading the FM signal.

NFR reception

To receive the Noise Free Radio signal, the front end of a standard AM receiver is used with the IF filter tuned to 462.66 kHz, Yazell said. The IF signal is run through a series of multipliers (Figure 2), resulting in a signal at 34.7 MHz with a maximum frequency deviation of 75 kHz. This is mixed with the output of a 24 MHz oscillator and routed to the

nal into the modulated oscillator. This will allow the receiver to decode the stereo audio the same as from a stereo FM station.

Due to the extremely small modulation index, Yazell said, NFR should not exceed the requirements of the NRSC RF mask. Berry plans to use a spectrum analyzer during the tests to verify NRSC compliance.

The closed-circuit tests indicated that the FM component does not interfere with normal AM reception unless the deviation exceeds 2 kHz, Yazell said. Al-

(continued on page 20)

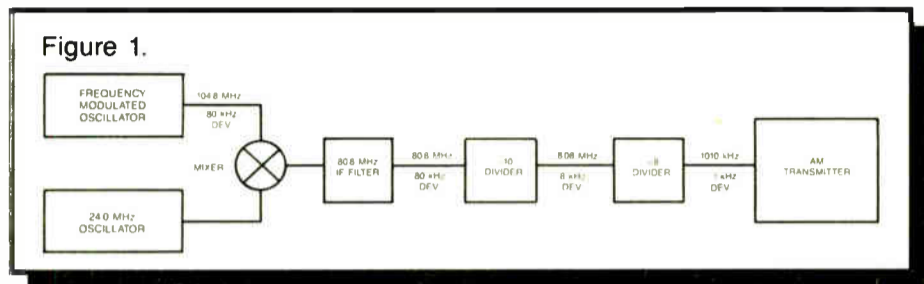

experimental authorization to begin over-the-air testing of NFR which was developed by retired professional engineer George Yazell.

Yazell introduced NFR to the FCC for consideration as part of the *en banc* hearing on AM improvement last November. He proposed the idea several years ago.

The advantages of NFR broadcasting, Yazell maintained, include wider audio frequency response and decreased interference due to the capture effect of FM receivers.

Test outline

WQYK technical operations director Frank Berry plans to conduct tests for a six-month period upon grant of the experimental authorization.

Specific tests, according to the application, include study of the effects of directional antenna signal nulls on narrowband FM, how co-channel interference affects the ability of a receiver to capture and hold the FM signal, the improvement in the received signal-to-noise ratio and the effects of amplitude modulation on a frequency modulated carrier at low operating frequencies.

Yazell has conducted closed-circuit laboratory tests to prove the principles

of the carrier will be frequency modulated with a maximum deviation of 1 kHz. The station will use a modulated oscillator from an FM exciter.

The frequency will be set at 104.8 MHz

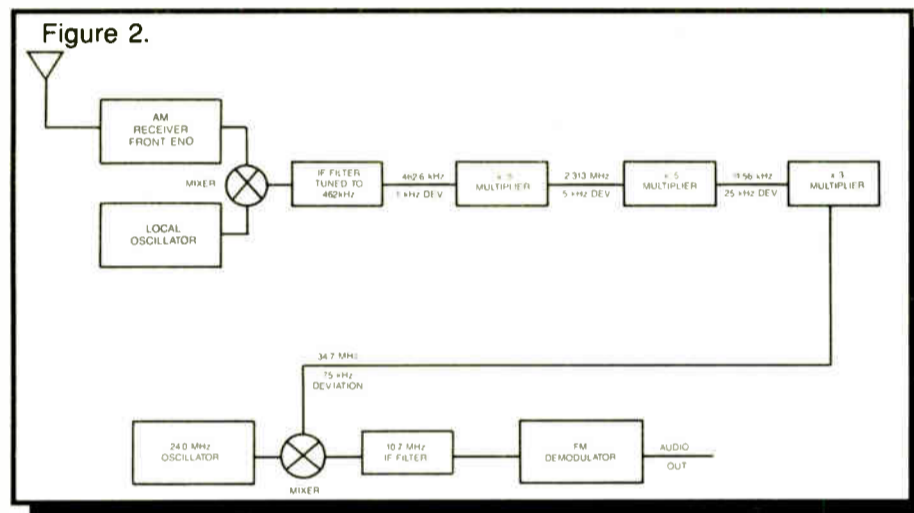

and modulated with a maximum deviation of 80 kHz (Figure 1). It will be mixed with the output of a 24 MHz oscillator and passed through an 80.8 MHz IF filter. (The frequency deviation still will be 80 kHz at this point.)

Then it will be divided by 10, result-

ing in a 10.7 MHz IF filter of an FM receiver.

At this point the signal is now identical to the IF signal in a standard FM receiver and is demodulated as such.

Once the initial tests are made with a mono signal, Yazell plans to add a stereo generator and feed a composite sig-



Radio's Only Comprehensive Reference Guide
The 1990 Radio World Annual

Your Source For . . .

- Complete Equipment & Supplier Information
- Radio World's 1989 Editorial Index**
- Phone Listings for the NAB & FCC
- Handy Reference Material

Also Featuring . . .

- The Top News Stories of 1989
- The Year in Pictures
- Earwaves Special
- Year-End Dubious Achievement Awards

All FREE with your subscription to **Radio World**, the industry's technical, engineering and news authority.

Coming in February . . . Watch for It!

Your Problem Solvers

from **ATI**

- Mike
- Line
- Phono
- Mixing
- Matching
- Metering
- Monitoring
- Processing
- Distribution
- Rack Mounting

AUDIO TECHNOLOGIES, INC.

328 W. Maple Ave., Horsham, PA 19044 • (215) 443-0330 • FAX (215) 443-0394

Eight MMB Dockets Get the Axe

by Charles Taylor

Washington DC The FCC terminated eight Mass Media dockets that it judged out of date and irrelevant to current Commission policy.

Each of the items was two or more years old, some dating back to 1978 and according to the Commission, "in general, the passage of time and related market changes rendered the records in the proceedings stale and not sufficient

for further action."

The termination of the proceedings, which also included five Common Carrier items, one Private Radio proceeding and one General proceeding, resulted from a comprehensive review of pending rule making and policy items initiated by Chairman Al Sikes in the fall.

"The public has a right to timely action on proposed changes in our rules and policies," Sikes commented in a press release. "If the Commission is unable to

of the Commission's Multiple Ownership Rules to Include Educational FM and TV Stations and MM docket 78-164, Amendment of the Commission's Rules Governing the Eligibility for Noncommercial Educational FM and TV Broadcast Station Licensees.

Also, the FCC terminated two items relating to minority preference stances that are scheduled for review by the Supreme Court in the spring: MM docket 85-192 to re-examine the "single majority stockholder" and "minority incentive" provisions of Section 73.3555 of the Commission's Rules and Regulations; and MM docket 85-299 regarding the distress sale policy of broadcast licensees.

Also terminated were MM docket 80-757 to amend rules concerning automation of the use of measurement data for AM stations; MM docket 83-403 granting comparative preferences within metropolitan areas; and MM docket 81-705 to eliminate the requirement that licensees retain letters received from the public.

The Commission also deleted from pending action a General Item prompted by the NAB in 1986. The item proposed to preempt broadcasters from strict state and local guidelines limiting the construction of broadcast towers because of alleged RF radiation.

RKO Can Sell WAXY

by Charles Taylor

Fort Lauderdale FL In one of the last RKO General proceedings before resolution of the dissolved company, the FCC approved a settlement agreement that will allow the company to sell WAXY-FM here for substantially less than fair market value.

Under the agreement, RKO would receive 60% of the proceeds from the sale.

Included in the settlement are dismissal of RKO's renewal application for WAXY-FM; dismissal of mutually exclusive applications of Adwave Co., COZIN Communications Corp., and Lauderdale Broadcasting Co.; the granting of South Jersey Radio's mutually exclusive application for the station; and the assigning of WAXY-FM's license from South Jersey to GRADH-105 Inc., which currently is a subsidiary of RKO.

GRADH-105 will be acquired by Ackerley Radio of Florida Inc., as part of the

transaction. In turn, Ackerley will acquire the physical and other assets of WAXY-FM.

Under terms of the agreement, Ackerley would pay RKO \$12.6 million and would pay \$8.4 million to the other applicants and their principals.

The Commission also approved a settlement for RKO on WHBQ-TV in Memphis, TN. RKO will receive 65% of the proceeds of the station's sale to Adams TV of Memphis Inc. Under the agreement, Adams would pay RKO \$25,350,000 and would pay \$13,649,999 to seven other applicants and their principals.

The two settlements move toward resolving 24 years of "protracted and highly complex litigation" involving 14 broadcast stations and 70 competing applications, according to the FCC. Remaining is a settlement for KFRC-AM in San Francisco.

For information, contact the FCC at 202-632-5050.

"The public has a right to timely action on proposed changes in our rules and policies. . ."

act in a timely fashion on the basis of the record before it, the proceeding should be terminated so that public uncertainty is eliminated."

Sikes added that the action taken puts the Commission in a position to act more efficiently in the future.

Items terminated relevant to radio included MM docket 78-165, Amendment

Second 3M Asset Sold

Huntsville AL Pesa Electronica announced it has acquired the 3M audio/video routing switcher and character generator product groups and associated advanced technology products presently in development.

This announcement comes as 3M revealed the sale of the ITC cart division to Canadian entrepreneur Donald William Carle.

The audio/video sale effective 1 January includes personnel and facilities in

Huntsville.

Pesa manufactures character generators, video signal monitoring and digital test generators, intercom systems, color monitors and RF transmission products.

Pesa, a member of the Amper telecommunications group, is described as a fast-growing Spanish electronics company with headquarters, engineering and manufacturing facilities in Madrid, Spain.



GET IT RIGHT
GET IT FROM ALLIED

PRE-OWNED LOOKING FOR NEW HOME!!



We selectively
BUY-SELL-TRADE
used broadcast equipment
Save \$\$ — Call today!



ALLIED
EQUIPMENT EXCHANGE
A HARRIS COMPANY

317-962-1471

635 SOUTH ST. • P.O. BOX 1487 • RICHMOND, IN 47374

© 1990 HARRIS/ALLIED

POWER...

60,000 WATTS

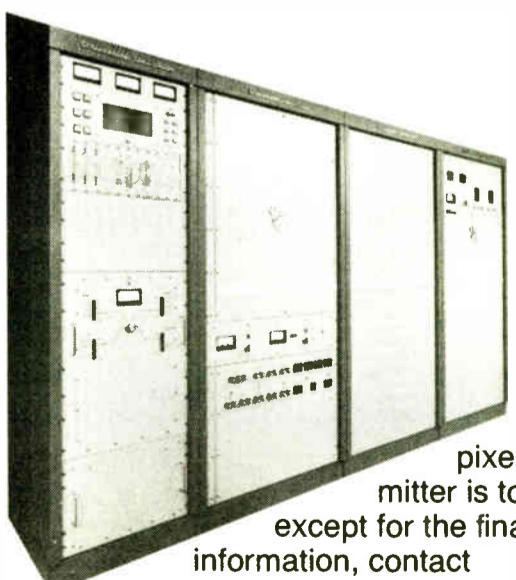

The 817A has a single output of 60kW and is totally self contained. An internal viewing screen provides seven screens on a pixel display. This transmitter is totally solid-state except for the final PA tube. For more information, contact

varian 

continental electronics division

P.O. BOX 270879 DALLAS, TEXAS 75227 (214) 381-7161 FAX NUMBER (214) 381-4949

Here's another reason we sell more cart machines than anyone else.

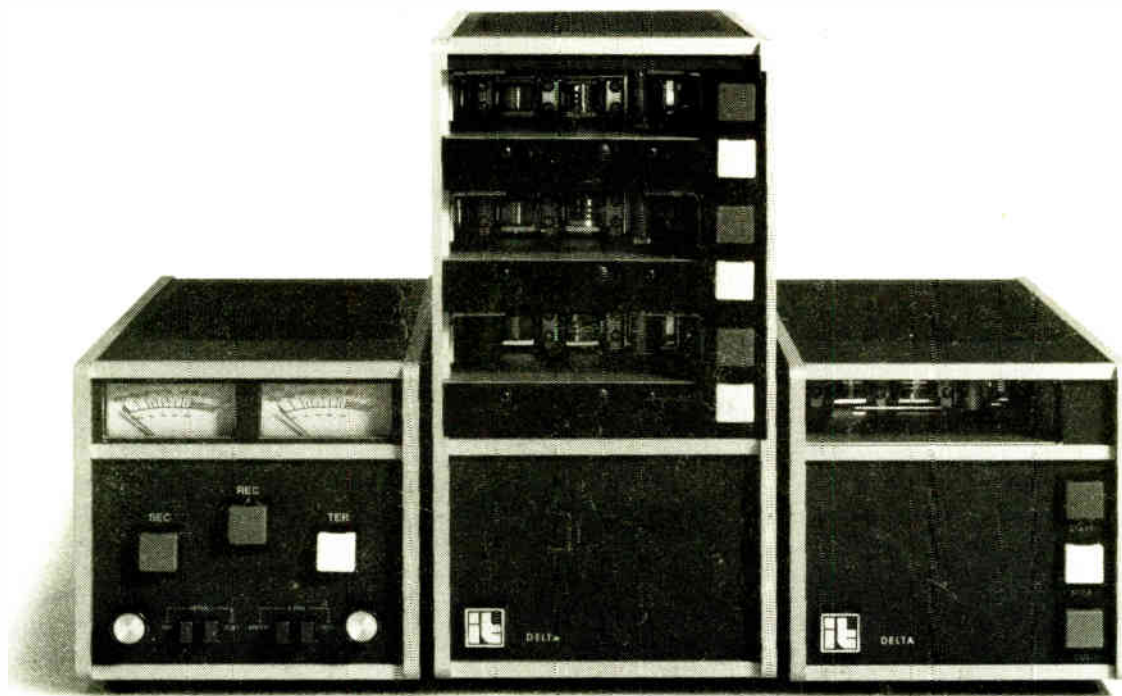

The Delta series. The world's most popular cart machine over the last five years.

And here are three more.

Our Authorized ITC Dealers

Allied Broadcast
Equipment
800/622-0022

Broadcast
Services Company
800/525-1037

Broadcast
Supply West
800/426-8434

3M International Tapetronics — The World Leader In Cart Machines.

RF Lighting an Ongoing Concern

(continued from page 1)

cause a maximum of 20% total harmonic distortion. He and other lighting representatives maintained the ballast should be of concern.

Energy efficiency programs are nationwide with 15 million households participating, according to Joe Vandenberg, director, technical service for the Edison Electric Institute, an association of utility companies. Figures, however, were not available on the number of programs involving light bulb replacement.

Vandenberg admitted that local utility companies probably are not aware of the effects on AM radio from RF emissions.

He said he has trouble with AM recep-

The bulbs cause splatter, not just on a single frequency, and the effect is more prevalent on the lower end of the spectrum, Morgan explained.

"It's something that broadcasters should look into and follow up," said NewCity Communications Engineering VP John Marino. "I think it should be a concern."

Potential quality problems?

Current mass production of the bulbs may not produce the same emission readings as the bulbs first tested, Marino suggested. The failure rate of the bulbs also is at question, he said.

"I can see a big problem if the quality isn't there," Marino said.

mission has to examine this.

"There is a small but persistent reminder to the Commission that some man-made interference needs to be examined."

FCC follow-up

The FCC proceeding conducted under docket GEN 83-806 concluded that existing regulations were adequate to protect authorized telecommunications services, even highly susceptible ones, such as AM and amateur radio.

The FCC, however, noted that the

agency intended to monitor development of RF lighting technology and, to the greatest extent possible, assist the industry to study further the interference potential of RF lighting devices as well as the susceptibility of receivers.

Broadcasters, at that time, disagreed with the Commission's stance and called for stricter regulations for RFI emission. The Commission studied conduction limits below the current 30 MHz and radiation limits above 30 MHz.

FCC Technical Services Chief Richard Engleman said the Commission would re-evaluate the standards if there were evidence to prove the lighting causes interference. But he said no such information exists at this time.

"There is a small but persistent reminder to the Commission that some man-made interference needs to be examined."

tion in his home, where there is a mixture of traditional and energy efficient light bulbs. "I've just about given up on AM (at home)," he said. He was listening to all-business AM station at his office when interviewed.

References to RFI are few—if at all—in literature on energy efficient lighting. But what there is minimizes any effect.

ABC Radio Engineering VP Al Resnick said the FCC should consider re-examining RF light emissions under the total scope of man-made interference. He noted several references to concerns with man-made interference during the *en banc* hearing on AM improvements.

"I think the Commission is going to examine this," he said. "I think the Com-

Sony, Tek Negotiate

Japanese Firm May End Up with Both Dubner And Grass Valley

Beaverton OR Any indication that Sony, which has a strong brand name recognition in professional broadcast equipment, is considering a move that could strengthen its position causes the industry to take notice.

Sony Corp. and Tektronix Inc. acknowledged in January they are negotiating a deal through which, according to one scenario, Sony could acquire Tek subsidiaries The Grass Valley Group (GVG) and Dubner Computer Systems Inc.

For its part, Tektronix wants full control—or an additional percentage—of Sony/Tektronix, a joint venture between the two companies established in 1964 for manufacture, sales and service of Tektronix product in Japan.

said he could not assess the stages of the talks that had been ongoing for "a number of months." He continued, "We don't know the timing. We don't have a trade. We don't have an agreement."

Subsequently, Sony Corp. of America's Public Affairs Director Stephen Burke issued a statement: "In response to Tektronix's interest in enhancing its business activities in the Japanese market, Sony and Tektronix have begun discussions to explore possible changes to the business relationship between the two companies."

While Burke said he could comment no further, Tektronix's Chamberlin described any transaction between Sony and Tektronix as a "natural evolution" of current business arrangements. In addition to the Sony/Tektronix connection, Sony has distributed GVG products worldwide, but mainly in Asia, for six years.

An eye toward Japan

Tektronix wants a larger part of the Japanese market, Chamberlin said, which is the largest market outside the US. Annual sales for Sony/Tektronix are \$200 million, he said.

In addition to a possible trade, Chamberlin said a transaction could involve a cash payment or an exchange of other assets.

GVG competitor Ampex did not respond to the announcement. But Marketing, Sales & Service PR Manager Dave Detmers noted that GVG would continue to be a competitor, whether owned by Tektronix or Sony. Sony and Ampex currently have a cooperative product development and reciprocal manufacturing agreement.

At Utah Scientific, Dave Spindle said the company is "disappointed" that Tektronix would sell an American-owned company to the Japanese. He also said such a transaction would make Sony a "100% supplier."



CRL SPOTLIGHT

Upgrading Your FM Processing?



The CRL FMIG audio processing system is the perfect answer for those of you with a small budget, but a large budget need for FM processing. With the FMIG you get the market's cleanest limiter the SMP-850, followed by the SG-800A digitally synthesized stereo generator. The SMP-850 features a powerful input compressor, followed by our exclusive variable transfer function pre-emphasis limiter. Image widening stereo sound field enhance circuitry is standard equipment. The SG-800A's digital pulse amplitude modulator produces a flawless baseband stereo signal. Find out what the FMIG can do for you. We have a two week trial program available. Call or write us for details.



CRL Systems
2522 West Geneva Drive
Tempe, Arizona 85282 U.S.A.
(800) 535-7648 (602) 438-0888
TELEX: 350464

Short on specifics

Tektronix disclosed the negotiations in a brief statement 4 January. Tektronix spokesman Fletcher Chamberlin

RK-RACK SYSTEM AUDIO SIGNAL PROCESSING



COMMON FEATURES

- THREE RACK UNITS OF SPACE
- INPUTS & OUTPUTS HAVE
- AUDIO TRANSFORMERS
- COMMON POWER SUPPLY-
- 100, 120, 240, 50/60 Hz
- REDUNDANT POWER SUPPLY FOR SAFETY
- SCREW TERMINALS FOR
- INPUTS & OUTPUTS

10 MODULES FOR AUDIO NEEDS

- | | |
|----------|----------|
| RK-PA | RK-AGDA |
| RK-VCADA | RK-DAADJ |
| RK-MLD | RK-ALC |
| RK-DA | RK-SC |
| RK-LA | RK-SB |

SEND FOR FREE CATALOG

SESCOM INC.

2100 WARD DR.
HENDERSON NV 89015 U.S.A.
22-565-3400, 800-634-3457, FAX 702-565-4828



HIGH PERFORMANCE AT AFFORDABLE PRICES

- New front panel programmable composite STL's
- New directly programmable FM composite receivers
- New options for synchronous boosters and translators
- New FM power levels: 2, 10, 20, 30, 80, 100, 200, 250, 500, 800, 1000, 1500, 1800, 2000, 3000, 3500, and 15000 W

BEXT INC.
739 Fifth Ave. San Diego CA 92101
TLX 229882 619-239-8462
FAX 619-239-8474

Audio Heats Up at Winter CES

(continued from page 1)
TravelPilot CD-ROM-based navigational system that shows the relative position of the car via an on-board electronic map.

On the FMX front

The FM stereo-enhancing FMX technology did not have any new companies on-board at CES. However, parent company Broadcast Technology Partners remains optimistic.

JVC and Alpine are currently the only companies offering the technology that underwent controversial scrutiny last year by Bose Corp. President and MIT



JVC's Hank Simon (left) and BTP's Lou Raymo with FMX receiver.

by the company is paying off with renewed interest by broadcasters and receiver companies.

"We've gotten much more aggressive with our marketing," BTP Broadcasting Industry Relations Director Lou Raymo said. "I just see a stronger interest."

He said Samsung has joined Sprague

Judging by the displays at CES, companies do not appear to have high hopes for AM stereo...

Semiconductor and Sanyo as companies producing the FMX decoder chip.

Since summer, BTP has been sending out a newsletter to broadcasters and receiver manufacturers, informing them about FMX product development.

Despite the optimism, several receiver companies that expressed interest last year have put their FMX plans on hold.

Proton Sales Representative Larry Waterman said his company has not yet decided if it will introduce any FMX-equipped receivers.

"It's still a possibility with us," he said. "I do like it."

Aphex exciter EQ

Waterman expressed more confidence in Proton's new equalizer, CQ-273, which is equipped with an Aphex aural exciter

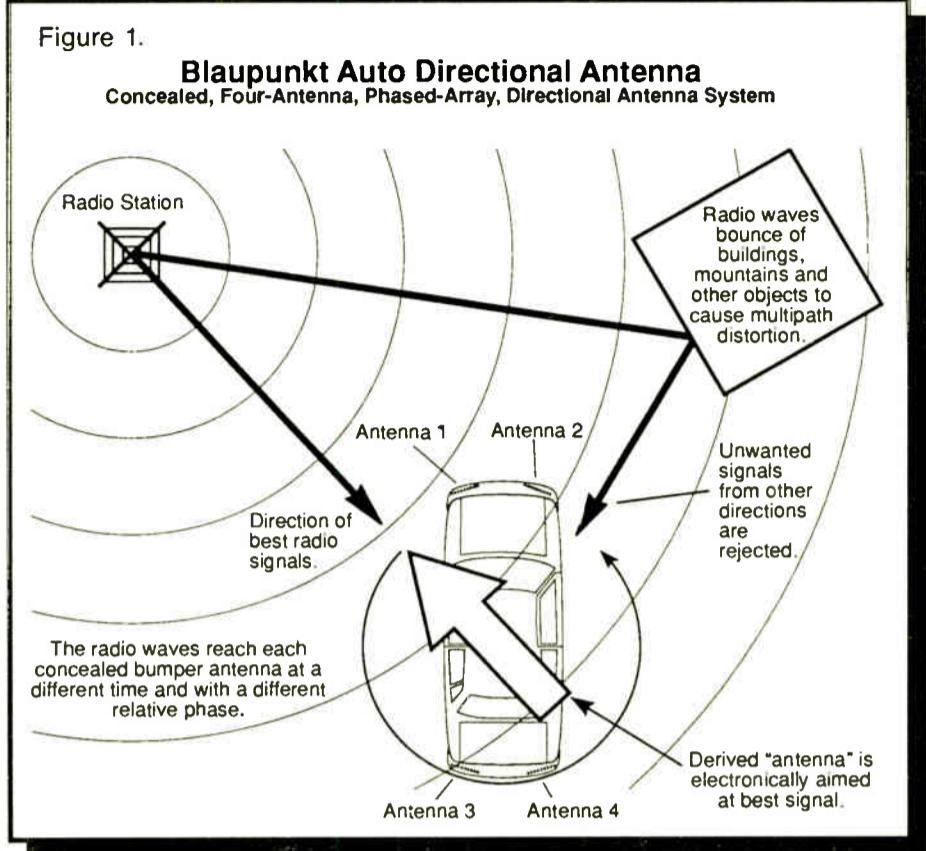

to increase high frequencies, especially on AM.

Blaupunkt's Sell said his company "has decided to back off on FMX."

Several companies, including Blaupunkt and Pioneer, said their latest FM receivers performed better than FMX receivers.

Judging by the displays at CES, companies do not appear to have high hopes for AM stereo either.

"It's popular in South America, but it's dying in the US," a Philips car receiver sales representative said.

Proton's Waterman said there is little (continued on page 12)

Little Noisemaker.



This little gray box is about to have a big effect on the way you test your audio equipment.

No longer will you have to bother with individual tones to set proper audio levels. With Delta's SNG-1 Stereo Noise Generator you can make a variety of tests with true stereo noise, all at the flip of a switch.

You'll get a much more realistic view of what your equipment is doing. Whether you prefer white, pink, or USASI noise spectra, the SNG-1 provides it, in both continuous and pulsed output modes.

Say goodbye to hit or miss processor adjustments using varying program material. The award-winning SNG-1 spans the entire frequency range, so you'll cover the highs, the lows, and everything in between.

The external gate input permits an infinite variety of pulse shapes and durations so you can test your equipment to the absolute

fullest. For standalone convenience simply switch to the internal pulse mode.

With the SNG-1 you'll always get an accurate and repeatable standard to base your measurements on. And for only \$495, there's no bigger value.

To discover how the Little Noisemaker can help you in a big way, call or write today. And be sure to ask for your free copy of Delta's Noise Primer, "Employ Some Noise." Delta Electronics, Inc., 5730 General Washington Drive, P.O. Box 11268, Alexandria, VA 22312. Phone: (703) 354-3350, FAX: (703) 354-0216, Telex: 90-1963.

The Above Standard Industry Standard.

DELTA ELECTRONICS



©1989 Delta Electronics, Inc.

CES Offers Glimpse of Future



(continued from page 11)
demand for AM stereo.

"If AM stereo was a big issue, our dealers would be beating us up for it," he said.

One significant new product for AM stereo did show up at CES, however.

It is called the world's first AM stereo/FM stereo portable radio, produced by Sangean, a Korean company. The radio (model SR-66) features C-QUAM stereo decoder, headphones and belt clip for a suggested retail of \$30 (call Sangean, 818-288-1661).

The radio was demonstrated to broadcasters at the SBE convention in Kansas City in October.

DAT and disc

Prototype consumer DAT recorders with the Serial Copy Management System (SCMS) were in abundance at CES, but no

(Above) JVC unveils SCMS-equipped consumer DAT
(Below) Technic's Logic "constant format" receiver
(Right) Recordable CDs: will they rival DAT?

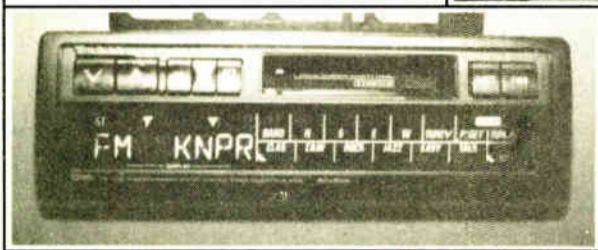

pected to be introduced in Congress shortly requiring SCMS on all consumer decks brought into the US.

Sony, JVC and Technics were among the companies that showed their SCMS-equipped prototypes at the show.

If the digital recording world isn't

Yuden entered into a partnership with Sony last year to produce limited runs of special order CDs using the recordable CDs and Sony recorder.

A Taiyo Yuden spokesman said there are no immediate plans to market recordable CDs as a consumer product, but some audio insiders believe it is only a matter of time.

One last CD item of note. More products are now showing up on the market, claiming to preserve disc life



definite release date was set by the companies. Industry insiders, however, said to expect them to hit the market by spring.

The SCMS anti-tape copying technology was agreed to last year by recording rights groups and manufacturers and is thought to be DAT's last chance to crack the consumer niche. Legislation is ex-

muddled enough, recordable CD talk seemed to be louder than ever at CES.

Taiyo Yuden, the Japanese company that produces "That's" audio tape, brought its recordable CDs for showgoers to hear.

The record-once CDs were demonstrated on a special Sony recorder. Taiyo

and, yes, to even improve disc fidelity.

Finyl's Impedance Matching Fluid was one such product at CES. According to the company, the fluid will improve stereo image, transient response and decrease noise and harshness. It is distributed by Transparent Audio Marketing in Hollis, ME.

The affordable GENTNER VRC-2000

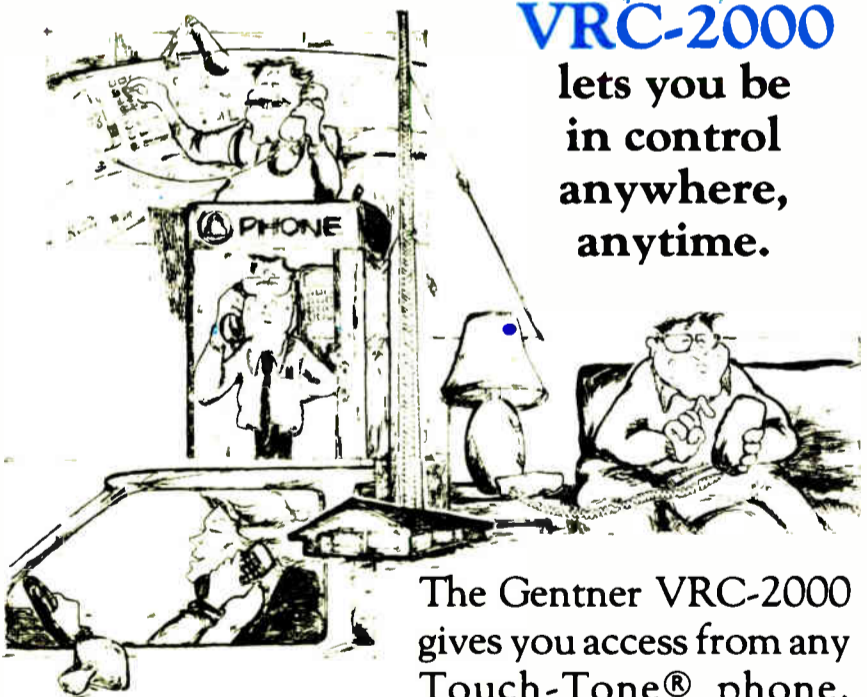

lets you be in control anywhere, anytime.

The Gentner VRC-2000 gives you access from any Touch-Tone® phone.

Automatic, alarm reporting is also featured. It's like having someone at the transmitter 24 hours a day. Call Northeast for all the details!



NORTHEAST BROADCAST LAB, INC.

Serving The Broadcast Industry Since 1961

Main Office P.O. Box 1179 S. Glens Falls, NY 12803 Tel: 518-793-2181 Fax: 518-793-7423	Mid-Atlantic P.O. Box 565 Southampton, PA 18966 Tel: 215-322-2227 Fax: 215-953-0523	New England P.O. Box 406 Auburn, NH 03032 Tel: 603-483-1002 Fax: 603-483-2352	Southwest P.O. Box 867717 Plano, TX 75086 Tel: 214-612-2053 Fax: 214-612-2145
---	--	--	--

FM Harmonic Low Pass Filters 500 - 50,000 Watts

Delivery: 30 Days (Faster For Your Emergencies)

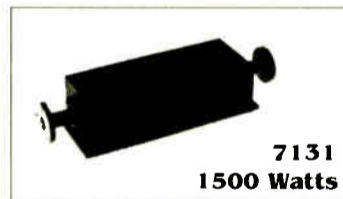
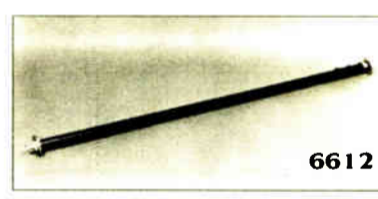

Model #	Watts
6612	6,000
6516	15,000
7772	30,000
7455	50,000



Bulletin #14

Full Details In Bulletin #14!

Also, request BTV/87 which describes TV/FM/MMDS Broadcast Filters & Combiners for service radio bands.

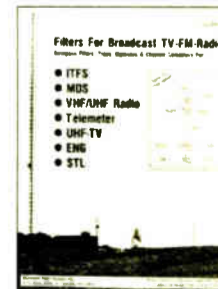

Catalog BTV/87

Need A Special Filter? Call Us Today!

"We make Filters In A Hurry For Customers In Trouble!"

Microwave Filter Company, Inc.
6743 Kinne St. • E. Syracuse, NY 13057
Toll Free(US/Can.): 1-800-448-1666 • Collect(NY/AK/HI): 315-437-3953
FAX: 315-463-1467 • Telex: 249-613

RADIO PRODUCTION 1990.

Total creative control,
starting at less than \$6,500*.

Interface easily to analog
and to all major digital formats.

Fast learning curve to
high creative output.
Difficult editing tasks
made quick and easy.

"Duck" a background
track beneath a voice-
over. Fade-out/fade-in,
with complete accuracy.

Time expansion and
compression—without
pitch change

Storage capacity from 10
minutes to 6 hours of
stereo digital audio.

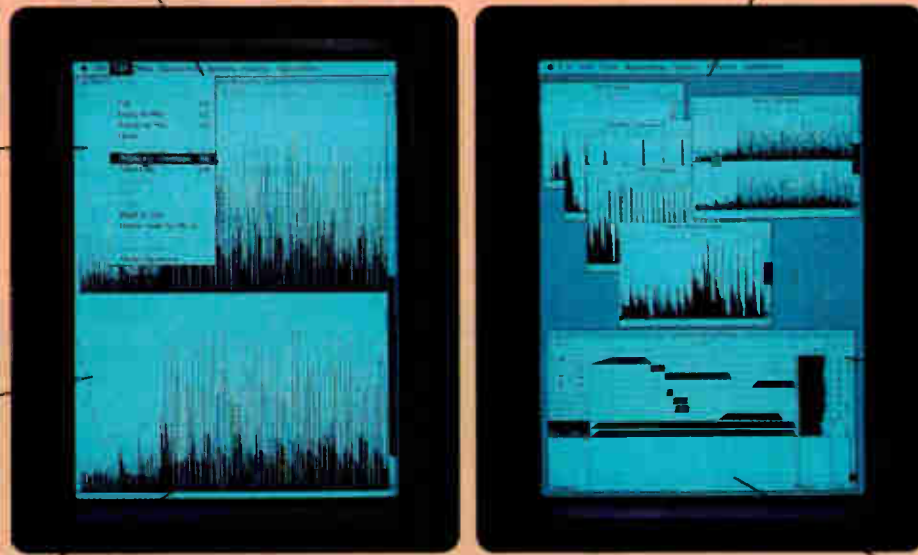

Superlative audio quality.
Multiple mixes and
multiple generations—
without degradation.

Easily expandable and
upgradable—now
and in the future.

STUDER DYAXIS. DIGITAL AUDIO HARD DISK FOR RADIO. YOUR LOW COST WAY TO BEAT UP ON THE COMPETITION.

Ratings wars—the push to get
advertisers—the crunch on operating
costs... You always need to move faster
and be better than the competition.

The station offering quick turn-
around and the ability to produce more
complex, sophisticated and creative
spots, jingles, promos and programs is
likely to be the winner. With Dyaxis,
you can *be* that winner. Your adver-
tisers love you. Your listeners love
you. And your competition hates you.

The Studer Dyaxis is the most

powerful and cost effective hard disk
digital recording/editing system
available, starting under \$6,500*—*proof*
that digital audio for radio doesn't have
to be expensive.

No ad can tell you all that Dyaxis
will mean to production at your station.
So call us at **800-366-4900** for our
12-page Dyaxis color brochure and
read about your exciting future in
digital audio editing with Dyaxis.

Now, *see* what you *hear*. On Dyaxis.
From Studer, a name you can trust.

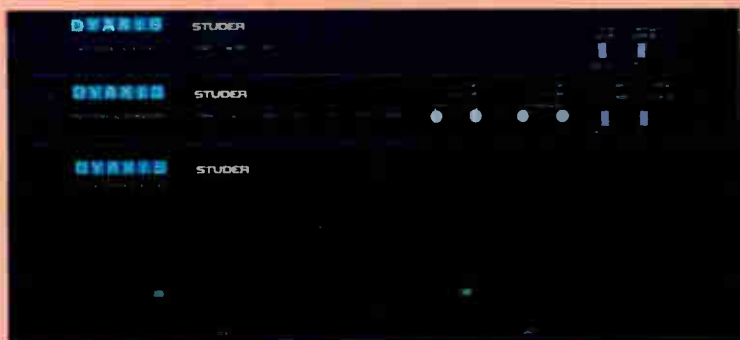

*Price not including Apple Macintosh computer.

STUDER REVOX

Studer Revox America, Inc.
1425 Elm Hill Pike • Nashville, TN 37210 • (615) 254-5651
New York (212) 255-4462 • Los Angeles (818) 780-4234
Studer Revox Canada Ltd., Toronto (416) 423-2831

NOW AVAILABLE
MacMix™ version 2.3
and
Excellerator/DSP Card

Circle 88 On Reader Service Card

World Radio History

DAT Copy Bill Expected on Hill

Las Vegas NV A bill requiring all consumer DAT players sold in the US to have the Serial Copy Management Systems (SCMS) anti-tape copying technology will be introduced during this session of Congress, according to comments made at the Winter Consumer Electronics Show here 6-9 January.

Rep. Robert Kastenmeier (D-WI) said the DAT bill could be introduced in its now-written or modified form by February.

The bill, drafted by the Electronics Industries Association (EIA) and audio experts, would stipulate that all DAT

recorders be equipped with SCMS.

SCMS is a Philips-developed technology that allows a DAT player to digitally copy from CDs and other digital and analog sources. The technology, however, imposes a limit on the number of copies that can be made from the original copy.

Anti-piracy measure

The technology was developed as an answer to DAT opponents who contend that a proliferation of DAT pirated copies could cost artists millions of dollars lost in revenue.

Recording artist organizations and

manufacturers agreed to SCMS last summer as a compromise. Proponents believe the agreement could finally help

ful of litigation by recording artist groups.

A healthy consumer market could also mean lower prices for professional DAT recorders and related products that are used by radio stations and recording studios.

Supporters of the SCMS technology

The bill, drafted by the EIA and audio experts, would stipulate that all DAT recorders be equipped with SCMS.

DAT get its proverbial foot in the consumer's door, which has not happened because manufacturers have been fear-

were in force at the CES. The Home Recording Rights Coalition (HRRRC) had its booth at the main exhibit area in the Las Vegas Convention Center promoting the DAT bill and "DAT Bill Yes" buttons were being worn by proponents.

The HRRRC also discounted efforts by some music industry people to link the DAT bill with a royalty tax on blank tapes.

Audio writer and consultant Leonard Feldman devoted a portion of his opening day keynote speech to DAT.

When You Consider Remote Possibilities...



PLXmicro Frequency Extender/Extender
Perfect complement to a cellular phone, transforming the sound to broadcast quality. Provides connections for microphone, tape and headphone. Compact size. Battery-operated. Full duplex operation.



Multiline Frequency Extender
The most sophisticated and easy-to-use frequency extender available. This versatile 1, 2, or 3 line system automatically dials, levels and equalizes your line at the push of a button. Incorporates Comrex unmatched noise reduction.

Consider Comrex. We're the people who pioneered the frequency extender and have set the standard in broadcast quality telephone transmission for nearly 30 years.

Comrex covers every remote possibility—in radio, television and teleconferencing. Comrex equipment is specified by networks and stations worldwide who understand the paybacks of Comrex dependability.

TH-1 Hybrid

Users say it's the "best hybrid we've ever worked with." Provides reliable broadband balance plus auto or manual answer, dual call start, adjustable ring count, caller mute and more.

TH-X Extender Hybrid

Picks up where the TH-1 Hybrid leaves off. Combines all of the TH-1 features with transmit/receive frequency extenders and automatic caller leveling. Ideal for use with the PLXmicro and cellular phone for two-way, on-air remotes.

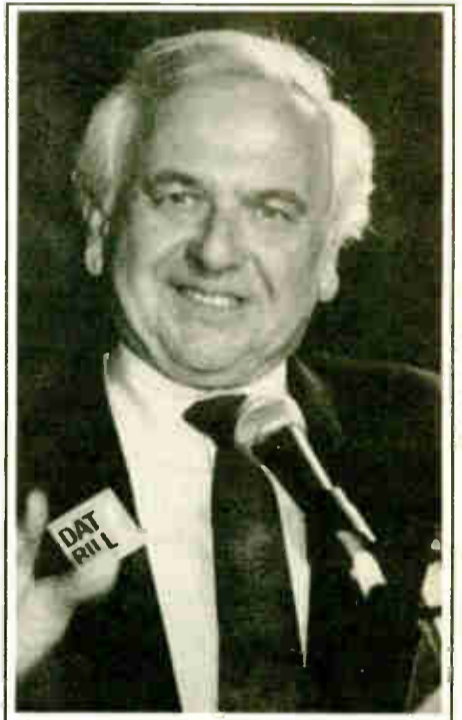

Audio expert Leonard Feldman spoke about DAT's future.

Feldman said that SCMS's implementation and a law requiring it on all DAT players eventually could help spur sales of DAT and bring the prices down.

But he cautioned, "Of course, the great DAT compromise was only an agreement to recommend legislation and it will only be effective if Congress passes a bill that makes it mandatory for all consumer DAT recorders to incorporate the SCMS systems."

Legislating technology

Feldman warned, however, that legislating a technology may also set a "dangerous precedent."

DAT manufacturers, including Sony, Technics and JVC, had prototype SCMS consumer decks on display at CES but were vague about exact market release dates.

Feldman predicted that DAT decks with SCMS would probably hit the market during the first quarter of 1990.

Analog is not dead, according to Dolby Laboratories, which brought its new Dolby S technology to CES. Dolby S is said to enable analog tape to rival DAT in sound quality.

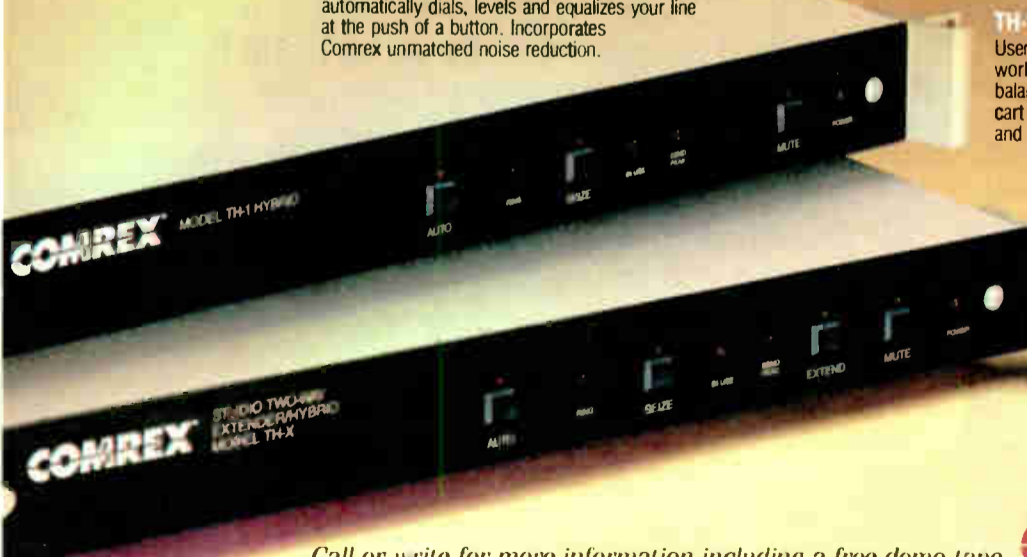

Call or write for more information including a free demo tape.

COMREX®

Comrex Corporation, 65 Nonset Path, Acton, MA 01720
1-800-237-1776 / (508) 263-1800 / FAX: (508) 635-0401

Berlin Wall a Barrier No More

by Dee McVicker

West Berlin WEST GERMANY Christian Eckhardt of West Berlin's SFB never actually said he felt like he was talking to a brick wall. But, of course he was. That brick wall, felled by political pressure in November, 1989, is what left his radio show on the deaf ears of East Berliners.

Not that they weren't listening; they were. SFB, a community of West German radio and television stations operating under the auspices of West German government, never had a problem penetrating The Wall into East Berlin.

Given its close proximity to the Iron Curtain, SFB's West Berlin broadcasts were virtually immune to this political barricade. Other forms of communication, however, were not as successful in breaking the Berlin Wall's concrete barrier.

As Eckhardt explained in his accomplished, European accent, "If you know (that by calling) somebody in East Berlin that (you've caused him) real problems; if you know things like this, you cut the communications."

OFFBEAT RADIO

But now, today, Eckhardt is being inundated by letters from his fans on the other side of The Wall. A communication that, up until recently, would have raised the ire of East Berlin officials.

Exchange of programming

Robert Barrett was a full-time engineer at WTXF-TV and a part-time disc jockey at WCZN-AM in Chester, PA, until recent health problems brought him out of the radio arena. He has raised the ire of some of these statehood officials.

Barrett and Eckhardt, both country mu-



A sentry of international flags decorates the front of SFB radio-TV in West Berlin.

was always getting mail from East Berlin," said Barrett, "long before The Wall came down."

On the show's second anniversary in June, Barrett flew to West Germany to do the show live. During his broadcast, Barrett greeted an East German country music fan, addressing him by name over the air. Not until later, when Barrett decided to pay a visit to East Berlin, did he learn of the problems his broadcast had caused his East German country music fan.

Arrested for possession of Pepsi

After crossing The Wall into East Berlin, and being arrested for possessing two cans of Pepsi and then questioned about his radio show on SFB, Barrett was told that the East German country music fan had been arrested. "He was a member of the Communist Party," said Barrett, "and Party members are not sup-

posed to talk or fraternize with the people from the West."

Although the East German listener and Barrett were eventually released, the experience was, as Barrett put it, "harrowing." And, there were other run-ins because of the Berlin Wall, he said.

During his visit to West Germany last February Barrett applied for permission to enter Brandenburg, East Germany. "I had met three people from a country

music club who were living in Brandenburg," he explained. "I wanted to visit them there, but they (the East German government) wouldn't give me permission to go there." The unofficial reason, claimed Barrett, was that the East German government did not want the media entering the city.

"Apparently," he said, "they felt something was wrong with having the media come into Brandenburg, which is not a tourist city. Media people just didn't go there. They were suspicious of that." After a political ballet with East German officials that lasted months, Barrett finally was able to meet his fans in East Berlin.

Barrett's experiences, said Eckhardt, are typical of the communication barrier that once existed between East and West Germany. Even Barrett's enthusiasm for country music was frowned on by East Germany's government, which had barricaded all Western forms of art including country.

"They (East German government) showed the people a lot of (movies) from Russia, Hungary, Czechoslovakia and Poland," explained Eckhardt. In contrast, West Germany imported American movies and even began adopting the West's enthusiasm for commercials to finance its media.

Prior to the dismantling of the Berlin Wall on 9 November, 1989, according to Eckhardt, "there was absolutely no communication between stations in West Berlin and stations in East Berlin."

German Schlager
To understand the significance of what has just taken place, Eckhardt introduced a German word: "Schlager," a form of music that is similar in lyrics to American country music—with similar ties to culture and heritage.

When the wall was erected after World War II, East Berlin was shut off from the Western world, and later from its Schlager music. Described by Eckhardt as "laugh music," Schlager was eventually reintroduced to East German listeners, but its style had changed drastically.

Reported Eckhardt, "They were not allowed to play swing music, or Glen Miller, things like that. Later on they didn't want to have Schlager either. And they tried to do other things (with music), but nothing worked out very well. So in the '60s and '70s, they did their own style of Schlager."

Schlager is now an open curiosity being explored by Germans. But it is not the only curiosity of two differing dominions. For radio, there are the matters of production, recording and in general how broadcasting is done on both sides.

"Today," said Eckhardt with the awe of someone who hardly believes his own words, "I had a visitor from an East Berlin radio station and he came to my boss to say, 'let's sit together and let's talk about how you do your programming and things like that.'"

Just a few months prior, this open line of communication was unthinkable. Even today it is hardly believable. At times, Eckhardt is still at a loss for words—even though his English is very good. The falling of the Berlin Wall and

(continued on page 34)



(Above) A view of SFB taken from a tower in West Berlin.
(Below) An East Berlin tower.



(Left) Robert Barrett at WCZN radio.
(Below) Joint German/American radio in West Berlin.



sic enthusiasts, met some years ago while Barrett was visiting SFB. The two began exchanging weekly radio programs, a novelty that has stretched across the Berlin Wall on more than one occasion.

Barrett's show, aired by SFB in exchange for Eckhardt's show which was aired by WCZN on Sundays, had developed a loyal listenership in Germany—some of it behind the Iron Curtain. "I

posed to talk or fraternize with the people from the West."

Although the East German listener and Barrett were eventually released, the experience was, as Barrett put it, "harrowing." And, there were other run-ins because of the Berlin Wall, he said.

During his visit to West Germany last February Barrett applied for permission to enter Brandenburg, East Germany. "I had met three people from a country

New FX 50 Exciter

Audio Performance That Rivals CD's

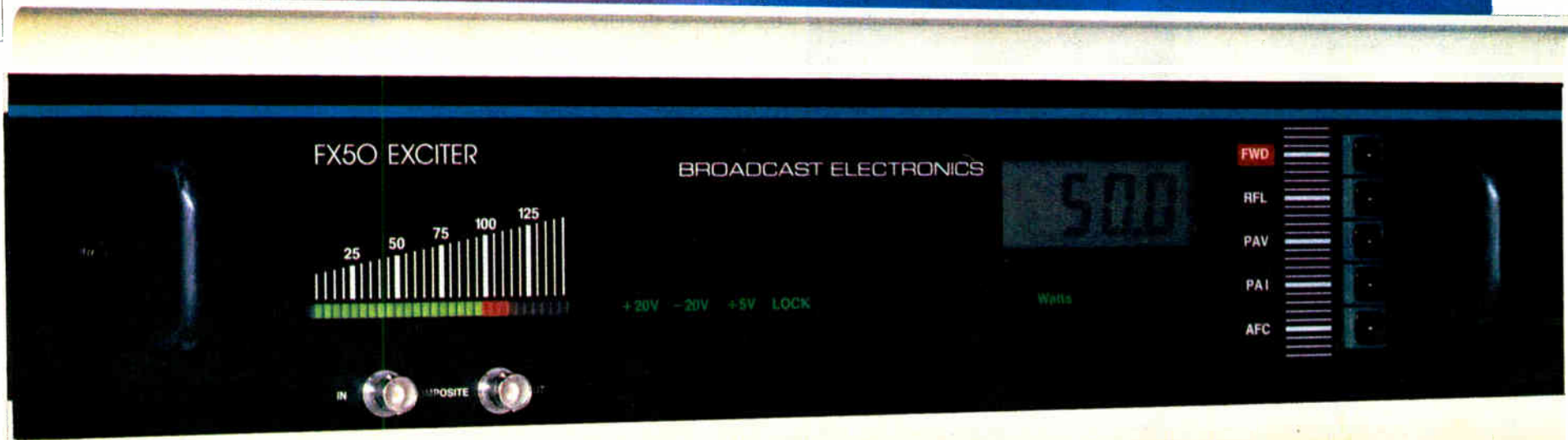

THD and IMD 0.003%, 93 dB S/N, 50 Watts

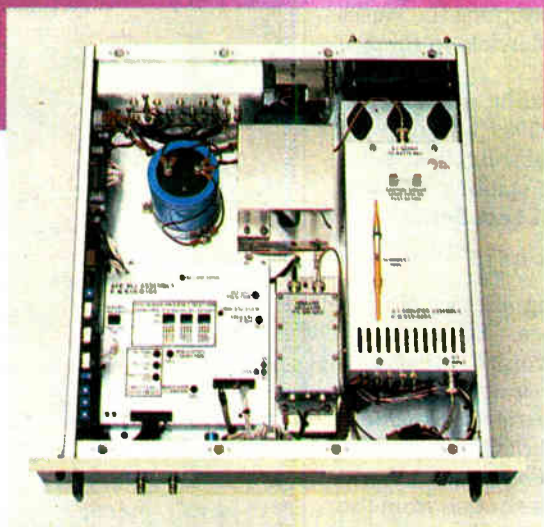

Broadcast Electronics introduces the ultimate FM Exciter - the new FX 50 - with performance even superior to the world standard FX 30.

CD Sound

The new FX 50 Exciter has the lowest distortion of any exciter available with THD and IMD of 0.003%.*

Move Up To CD Standards

Every new "B" Series FM Transmitter incorporates the FX 50 for true CD transparency. And, the FX 50 is the ideal retrofit for your present exciter.

*Typical

CD Dynamic Range

With a signal to noise ratio (S/N) of 93 dB* the FX 50 can handle all of the nuances and power of compact discs.

Set It And Forget It — 50 Watts

Sophisticated automatic control systems assure stable and reliable 50 watt MOSFET power output even under mismatch conditions.

For information on the FX 50 Exciter and on Broadcast Electronics' new "B" Series FM Transmitters which incorporate the new FX 50 Exciter, call Bill Harland or Russ Erickson at 217-224-9600.

BE® **BROADCAST ELECTRONICS INC.**

4100 N. 24th ST., P.O. BOX 3606, QUINCY, IL 62305-3606 U.S.A., PHONE (217) 224-9600, TELEX 250142, FAX (217) 224-9607

Circle 12 On Reader Service Card

World Radio History

Doing Radio the Cowboy Way

by Henry Fennell

Nashville TN It begins with a harmonic coyote howl, a rifle shot, a cattle stampede and a bellow from announcer Texas "Bix Bender": "Riders' Radio Theater is on the air." What follows is a 29-minute blitz of western music, modern satire, hokey melodrama and pure fun.

WPLN Productions in Nashville, Tennessee delivered 52 episodes of the program to public radio stations across the country and to the entire continent of



Ranger Doug: Idol of American Youth

Australia. CE Carl Pedersen has been given the highest award given by The Corporation for Public Broadcasting for technical achievement.

Riders in the Sky come calling as performers who disdain the "Easy Way" for the "Cowboy Way." Pedersen approaches the live to tape program in much the same way. "I want listeners to feel like they are in the live audience," Pedersen explains. He tries to achieve this intimacy in ways that are slightly unconventional.

He shuns PA type microphones for microphones that will deliver much better recorded sound. Pedersen believes in looking for "a fresh approach" when faced with traditional challenges such as the balance between house and recorded sound. His ultimate aim is a "warm and seamless sound." "The mix," he believes,

"should be transparent" with each element of sound complementing the others.

Riders' Radio Theater has gained great favor from listeners for its unique style and content. The program thrives on the varied talents of the "Riders in the Sky." The three principals are Ranger Doug, Too Slim and Woody Paul.

Doug plays rhythm guitar and stretches his big western baritone voice to produce amazing yodeling. Slim is the bass man and Woody Paul has earned his label of "King of the Cowboy Fiddlers." At its best, the group meshes for precise vocal harmonies.

Each member can also provide strong lead vocals, and each has written original western tunes to complement the western standards they perform on the show. Riders in the Sky are accompanied by accordion player Joey Misculin, or "Joey, The Cow Polka King."

Mixing for effect

The music mix is the responsibility of veteran Nashville studio engineer Tom Knox. Knox works in tandem with Pedersen, who handles the sound effects and audience microphones during taping.

Special consideration is given to recording the tight harmonies which are the musical trademark of Riders in the Sky. Ranger Doug's vocal mic is front and center. He is flanked by Woody Paul slightly left of center and Too Slim slightly right of center. The left and right vocal microphones are deliberately placed closer to center than normal to achieve a more satisfying, closer blend of voices.

Reverb is panned hard left and right and mixed back in through a high level return with appropriate EQ. Knox feels the hard left and right reverb helps spread the stereo image without compromising the desired vocal blend.

Reverb parameters are adjusted to match the performance hall's reverb characteristics and to boost the live feel of the mix. Electro Voice 100 speakers are used for control room monitoring and mixing. "You just can't get balances and instrument placement right on head phones," Knox notes.

Beyond the music, Riders in the Sky deliver laughs in a fashion reminiscent of the Smothers Brothers plus one, or perhaps the Marx Brothers in chaps. Listeners may be treated to plugs from



Riders in the Sky play live before an audience at WVXU.

imaginary sponsors such as "The Bio-Feed Bag" or the "Bovine Psycho Research Institute." Each "Rider" can call on a number of characters from within to add comic punch to the proceedings.

Steve Arwood is announcer "Texas Bix Bender: The voice that sold a million baby chicks over border radio." Steve's work holds the program together much in the style of the booth announcer from the golden era of radio. Arwood is also a principal writer for the show along with Fred "Too Slim" Labour.

The floor sound effects man is "Big Zeno Clunker," known to his close fans as musicologist and radio producer Bruce Nemerov. Zeno serves up live effects from a collection of trinkets and props, as well as the pre-recorded carted effects prepared prior to the broadcast. A second cart machine devoted to pre-

recorded sound effects is operated from the booth.

Sound effects often come in rapid fire succession. Everything from freeway to casino sounds are carted for location ambiance in the weekly melodrama. More sudden dramatic or sequential effects such as explosions, crashes and building or bridge collapses are also compiled prior to taping and brought into play from the second cart machine. The Riders may also contribute to this montage. The engineer may mix sound effects from six separate sources simultaneously.

The diversity of the program and the tension of its live performance present an on-going challenge to Pedersen and his crew. To complicate matters, the show has been taped with audiences in six different locations in the past year.

Setting up gear

WPLN productions began at ground zero with the show. The first task was to outfit the company for these recordings. Pedersen first chose to link two portable Studer consoles for both sonic quality and ease in moving between locations. The Studer 169 with 10 inputs was selected for sound effects mixing, while a Studer 269 with 16 inputs was picked for the music mix.

Two Studer 807 tape machines were the original choices to tape Riders' Radio Theater. The second machine was employed for redundancy. The Studers are run at 15 ips using Ampex 456 tape.

A Panasonic DAT recorder was put on line in mid-season. Tape modulation noise is down and the overall SNR on tape has improved with the DAT ma-

(continued on page 18)

Great Sounds From Great Cartridges

ARISTOCART

*Superb in Quality
Supreme in Economy*

SPACE SAVER UNITS
Aristocart's compact racks are simple, lightweight, rugged and ready to wall mount.

Model AW-20, holds 20 cartridges

Model CD-40, holds 40 discs

Place your order today or Call, Write or Telex for descriptive literature

Aristocart

Western International Communications Ltd.
17 - 825 McBride Boulevard, New Westminster, B.C. V3L 5B5
TELEPHONE (604) 526-3214 TELELEX: 04-34639

Circle 40 On Reader Service Card

World Radio History

RF SPECIALTIES GROUP

LEADERS IN RF SYSTEMS FROM COAST TO COAST

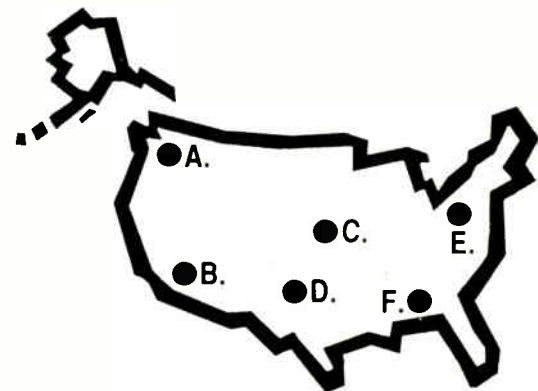

A. RF Specialties of Washington, Inc.
19237 Aurora Avenue N.
Seattle, WA 98133
Phone (206) 546-6546
FAX (206) 546-2633
John Schneider & James Kaplan

B. RF Specialties of California
3463 State Street, Suite 229
Santa Barbara, CA 93105
Phone (805) 682-9429
FAX (805) 682-5170
Sam Lane

C. RF Specialties of Missouri
R.R. #2, Box 152H
Kearney, MO 64060
Phone (816) 635-5959
FAX (816) 635-4508
Chris Kreger

D. RF Specialties of Texas
P.O. Box 7630
Amarillo, TX 79114
Phone (806) 372-4518
FAX (806) 373-8036
Don Jones & Tim Hawks

E. RF Specialties of Pennsylvania, Inc.
121 Conneaut Drive
Pittsburgh, PA 15239
Phone (412) 733-1994
FAX (412) 327-9336
Tom Monahan

F. RF Specialties of Florida
P.O. Box 397
Niceville, FL 32578
Phone (904) 678-8943
FAX (904) 729-2744
Bill Turney

Each Office is Independently Owned and Operated

FOR ALL YOUR BROADCAST EQUIPMENT NEEDS, CALL THE SPECIALIST NEAR YOU

SYSTEM DESIGN
COMPETITIVE PRICING



Circle 54 On Reader Service Card

"Wild West" Radio

(continued from page 17)

chine, according to Pedersen. He noted that the "DAT sounded surprisingly close to what we heard on the console program feed."

The recording capacity of this set-up has been pushed to the limit in the past year. *Riders' Radio Theater* has welcomed single guests such as Bill Monroe, Suzy Boggus and John Hartford, as well as



Too Slim: Man of a dozen friends

widely varied ensembles such as Asleep at the Wheel, Wild Rose and The Nashville Jug Band. The "Jug" has no set

number of members, but at least 20 players showed for the *Riders' Radio Theater* taping.

A 24-channel mic splitter was custom built from Jensen transformers and is used to isolate the house and broadcast boards. A separate high level auxiliary mix from the broadcast effects board is fed to the house board through this splitter. The mix supplies recorded sound effects for the house and for the performers.

A wide variety of mics are required for the various aspects of the show. The multi-purpose Electro Voice RE-20's were selected by Pedersen for vocal applications for several reasons. He cites their "very smooth low frequency response both on and off axis."

He also likes the "rugged dynamic" nature of the microphones which eliminates the need for phantom power and its possible accompanying problems. The RE-20 was also put into unconventional duty to fatten the sound of Ranger Doug's rhythm guitar.

Low-cost miking gem

Pedersen believes he found a low cost gem in experimenting with the miking of the string bass used by Too Slim. The Electro Voice ND-308 was mounted in a piece of cut-foam in the bridge of the bass and directed at a 45° angle toward

the body of the instrument. This configuration helps to reduce sound leakage from the performer monitors and sound wash on the body of the bass.

The bass is mixed a bit heavy to help fill out the sound of the small musical group. The 308 has since been used in the recording of *Riders in the Sky's* new album for MCA records, after it was found to outperform a Neumann FET-47.

Three Shure SM-58's are hung directly



Woody Paul: King of the cowboy fiddlers

over the audience. The combination is spaced approximately 20-feet apart and is panned hard left, center and hard right. Pedersen feels it's important "to fill the hole in the middle" that results from the use of two audience microphones that have been panned hard left and right.

The SM-58's deliver a natural low frequency roll-off to help off-set any

"boomy" effect the house system has on the broadcast mix. Many times the audience is asked to become part of the production by producing large-scale sound effects during tapings. Among other duties, the audience has served as a swarm of "killer bees" and a pack of "prairie guard dogs."

Valley dynamite limiters are called into duty on all vocal channels. A Yamaha SPX 90 supplies reverb for vocals. Peak limiters are on line to guard against sudden loud bursts from live gunshots heard on the show.

These 52 episodes of *Riders' Radio Theater* had been produced by WPLN under a grant that underwrote production costs. Unfortunately that funding ran out last September, and the program went into a hiatus of reruns, with the exception of a Christmas special.

But *Riders' Radio Theater* is back in the saddle again, with new production continuing at WVXU on the campus of Xavier University in Cincinnati, OH.

The show has served as a testing ground for some innovative ideas both in program content and engineering. This mixture has produced favorable results for audiences on both sides of the globe. Pedersen cites one final, simple key in producing an award winning radio program. "Pay attention to details," he advises. No, it's not always the easy way, but "it's the Cowboy Way."

■ ■ ■

Henry Fennell is announcer/producer at WPLN, Nashville and can be reached at 615-353-1810. For more information about the show contact Chuck Ingram or Larry Ashcraft at WVXU at 513-745-3738.

It's Not Just A Phase We're Going Through.

The tremendous success of the Tannoy PBM series of reference monitors is by no means coincidental. Since the introduction of the world renowned NFM-8 nearfield monitor, much time and effort has been spent on discerning the needs of the mixing engineer and the applied requirements of "playback monitors". The PBM Line exemplifies this commitment to excellence in reference studio monitoring. These compact loudspeakers sport robust poly cone mid-bass transducers utilizing efficient long-throw, high power voice coils. The low frequencies are carefully controlled by optimally tuned ports located on the rear of the loudspeakers. Hi frequencies are provided by Hi Power ferro fluid cooled polyamide dome tweeters which extend H.F. bandwidth beyond 20KHZ. The driver accompaniment is knitted

together by means of a precision hardwired crossover unit, utilizing robust low loss components, and heavy-duty input terminals which will accept standard 3/4" spaced banana plugs and the majority of high quality, specialist audio cables. Transducers and crossover assemblies are neatly housed in a stylish, high density, partial wrap cabinet, specially designed to minimize unwanted cabinet resonance, and high frequency reflection. In summarizing, we have left the best feature of all for last "price versus performance."

TANNOY
Professional Products



TANNOY

Tannoy North America, Inc. 300 Gage Ave., Unit 1, Kitchener, Ont., Canada, N2M 2C9
Telephone (519) 745-1158 Telex 069-55329 Fax (519) 745-2364

Circle 46 On Reader Service Card

TURBO CHARGE

Your Optimod™ 8100 with CALIFORNIA DIGITAL DIGIMOD 2000™

DIGIMOD 2000™ A 3 circuit card package transforms a standard OPTIMOD 8100™ into a multi band, digitally controlled processor, delivering maximum, competitive processing when using compact disc and R-Dat.

Call your favorite dealer for price and availability.

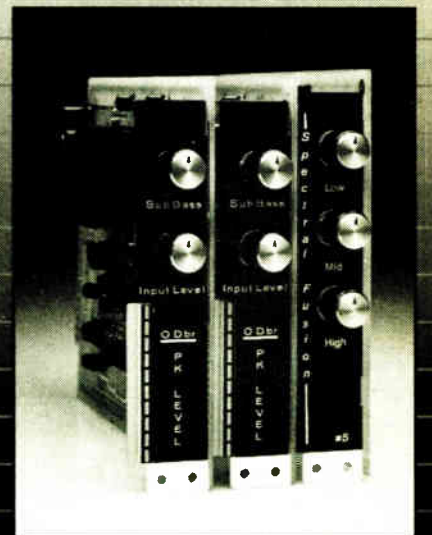

California Digital

Audio Systems

Dealer List:

1. BROADCASTERS GENERAL STORE:
Ocala, FL (904) 622-9058
Marietta, GA (404) 425-0630
Carol Stream, IL (708) 231-7120
Arlington, TX (817) 275-1380
2. BROADCAST EQUIPMENT SALES:
Jackson, MS (601) 857-8573

DISTRIBUTED BY: Family Marketing Group
DEALER INQUIRIES INVITED...904-622-2779

Circle 63 On Reader Service Card

NRSC Drafts AM Receiver Specs

by John Gatski

Las Vegas NV The National Radio Systems Committee (NRSC) signed off on the final draft of its AM receiver performance standards recommendations and mailed out ballots for total membership approval on 17 January, according to NRSC members.

The NRSC approved the

Stereo transmission has not been included as part of the specification . . .

voluntary specifications for the so-called "certification mark" for high-fidelity AM radios. The specs were tentatively worked out last fall and call for a frequency response of at least 50 Hz-7500 Hz, +1.5 dB, -3.0 dB.

Stereo transmission has not been included as part of the specification, and while the frequency response is only specified to 7.5 kHz, at the urging of broadcasters the NRSC AM subgroup left open the possibility that manufacturers could design a radio that goes beyond that point.

The action was taken 9 January at a full NRSC meeting held during the Winter Consumer Electronics Show. This was the

Departure at Varian

Palo Alto CA Norman Pond resigned as president and a director of Varian Associates "to pursue other business interests," according to the company.

The decision follows a September announcement that Varian Chairman and CEO Thomas Sege was planning to search for a successor as chief executive under his plan to step down from the post by the age of 65 in 1991.

Pond came to Varian in 1984 from Teledyne Corp. He was named president in 1987.

Senior VP Richard Levy has been appointed president of the company's Semiconductor Equipment Group, a post filled by Pond on an acting basis for the past several months.

Tim Guertin, radiation division GM, has been given additional responsibilities as acting president of Varian's Medical Products Group, previously headed by Levy.

The Wall Street Journal reported that Pond's departure is a delayed response to the announcement of a search for a new chief executive by Sege.

first meeting of the NRSC since the NAB barred reporters from attending.

The recommendations will be used for the planned certification mark the NAB and the Electronic Industries Association will promote to receiver manufacturers this year.

NRSC Chairman Charlie Morgan said ballots are due back from the membership by mid-February and approval is expected.

Other draft recommendations include: no more than 2% total harmonic distortion within the 50 Hz-7500 Hz bandwidth, cir-

cuitry to attenuate 10 kHz adjacent channel carrier frequencies by 20 dB with NRSC preemphasis or 30 dB without.

The standards also recommend several measurement procedures.

Morgan said a lot of hard work went into development of

the standards in the last year-and-a-half and special thanks go out to the NAB and EIA.

"Certainly, it has been a successful effort," Morgan said.

For more information about the NRSC AM receiver standard, contact Stan Salek at the NAB 202-429-5391.

Digital Frequency Extension

The only way to squeeze more sound out of the telephone line is to squeeze more sound into it.

The telephone bandwidth, 300 to 3300 Hz, is its biggest limitation. Anything below 300 Hz is lost forever. The result: your remotes sound like they're broadcast from inside a 55 gallon drum. But now there is a solution.



THANKS TO GENTNER, I'M ON-AIR FAST AND SOUNDING GREAT!

How We Squeeze More Sound Into The Phone.

It's called Frequency Extension, though it would be more accurate to think of it as Frequency Recovery. Basically, before the signal goes down the phone line, we digitally up-shift the signal 250 Hz. This "squeezes" the low frequency information, normally lost, into the phone line. When the signal gets to the station, we digitally down-shift the signal 250 Hz to recover the low frequency information. What reaches your listener is a fuller, richer, more natural sound.

At Gentner, You Don't Just Get A Box, You Get A Choice.

In the studio, you options start with the EFT-100, a low cost unit designed to be used with your existing hybrid and our new SPH-5E, a combination frequency extender and full-featured on-air telephone hybrid. The SPH-5E gives you the superior audio quality associated with frequency

extension plus, at the touch of a button, the added benefits of a telephone hybrid.

For frequency extension from the field, the EFT-900 and EFT-1000 expand on the capabilities of the EFT-100. With internal mic and headset amplifiers and telephone couplers, you will haul less into the field and get on-air much faster. The EFT-1000 even includes auto-answer and auto-setup functions.

All Gentner extenders include filtering to reduce hum, built-in noise reduction and special processing of the high frequencies. Best yet, Gentner extenders are full duplex devices allowing true two-way communication. You get cues back to the broadcast site without compromising the effectiveness of your remote system or juggling unnecessary hardware.

Would You Believe Broadcast Quality Audio From Telephone Lines?

That's right, we said broadcast quality. The newest addition to our growing line of frequency extenders, the EFT-3000, gives you enviable frequency response of 50 Hz to 7.5 kHz over three standard (dial up) telephone lines. The EFT-3000 is broadcasting's first and only three-line digital frequency extender. And, it's a breeze to operate. Just plug in the phone lines and speed dial the station from the DTMF pad on the front panel. Then punch the Auto-Setup button. The EFT-3000 tweaks all three lines and you're on the air. You even get inputs for two mics and two headsets so you can do two person remotes without all the extra gear.

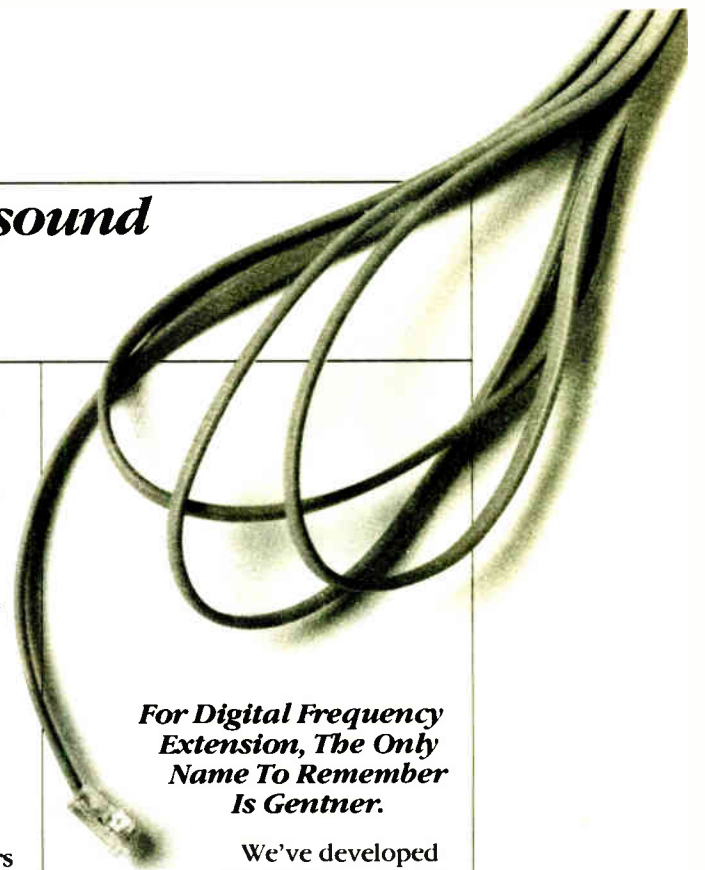

For Digital Frequency Extension, The Only Name To Remember Is Gentner.

We've developed the widest range of frequency extenders so you can easily squeeze just the right product into your system and your budget. For additional specs and the name of your Gentner dealer, squeeze a couple of minutes out of your busy schedule right now, and give us a call.



THIS THING SPEED DIALS, SETS LEVEL AND EQ AND MAKES ME SOUND LIKE I'M IN THE STUDIO!

GENTNER

Gentner Electronics Corporation
1825 Research Way
Salt Lake City, UT 84119
(801) 975-7200
Fax: (801) 977-0087

Radio Board Probes Key Issues

by Charles Taylor

Rancho Mirage CA A look at digital transmission for radio was one new area the NAB Radio Board ventured into at its annual winter meeting here in mid-January.

Deliberations on radio license reform and technical improvements, AM stereo and the certification mark for improved radio receivers highlighted the agenda for radio-related issues at the NAB Board of Directors meeting.

The annual meeting was held 14 to 17 January here at the Southern California Rancho Mirage resort. While radio dis-

cussions appeared to focus on well-established issues, according to information NAB released on the private meetings, the overall emphasis appeared to be more directed toward issues more relevant to television.

Issues of relevance

In a meeting of the organization's Joint Board of Directors, Government Relations Executive VP Jim May identified issues of the greatest concern in the coming year. Settlement of the Fairness Doctrine, continued reform of broadcast licenses and technical improvements were among the top priorities.

NAB General Counsel Jeff Baumann noted major issues of relevance before the FCC, including indecency, EEO, broadcaster character qualifications, Federal Aviation Administration clearances on tower emissions, renewal reform, FM translators and AM improvement.

The feasibility of TV Marti, the proposed sister to the already established Radio Marti by Voice of America, was reported on by NAB international consultant Bill Haratunian. He noted that NAB has formally requested that independent industry engineers evaluate upcoming feasibility tests for the project. NAB recommended that any alternate

system contemplated for TV Marti should be tested before the White House decides to begin broadcasting TV Marti. TV Marti is of interest to radio members because of possible jamming of radio frequencies by Cuba in retaliation.

Amend technical improvement bill

May presented a report on legislative activities and prospects. The NAB Radio Board then passed a resolution instructing the staff to seek an amendment to the radio technical improvement bill to codify what NAB said was the FCC's abuse of process action relating to radio license renewals.

Looking toward the future, the Radio Board also received a report from executive VP of Operations John Abel on developments in digital broadcasting and its implications for US stations.

Digital transmission methods have been tested in Europe and could involve satellite or over-the-air transmission methods, but utilize more spectrum space. The Board instructed NAB staff to monitor the development of digital radio.

Tom Kushak reported to the Radio Board that four candidates for final selection of a single service mark—the so-called "certification mark"—for improved AM radios have been identified by NAB and the Electronic Industries Association (EIA). Each is being checked for copyright registrability, he said.

John Abel added that he is negotiating with manufacturers for the manufacture and sale of the receivers.

Finally, the Joint Board examined, discussed and approved a \$17.1 million operating budget for the fiscal year starting 1 April.

For information, contact the NAB at 202-429-5350.

**OVER 420
STATIONS
HAVE CHOSEN
THE 1 THAT
SOUNDS BEST.**

Want proof that the fifth-generation solid-state Harris THE-1 FM exciter is the one for your station...plus a great deal?

Go for our THE-1 Sound-Off/Trade-In Challenge.

Try THE-1 for 30 days. Compare it with your present FM exciter and hear the difference in your station's sound for yourself. Now, if you don't agree that THE-1 sounds better, just return it to Harris, and the deal is off. But experience tells us that you probably won't want to go back to your old exciter. So pack it up and send it to us—no matter what the condition of your old unit, we'll give you a generous trade-in allowance towards the purchase of your new THE-1!

Since its introduction at NAB '88, over 420 stations worldwide have discovered that THE-1 is the exciter that sounds as good as it specs. This special THE-1 Sound-Off/Trade-In Challenge no-risk offer ends on March 31, 1990. Don't miss out on a great deal—call Harris Radio RF Sales today at 217-222-8200, Ext. 3401.



HARRIS

Harris Broadcast Division • Marketing Department
P.O. Box 4290 • Quincy, IL USA 62305-4290

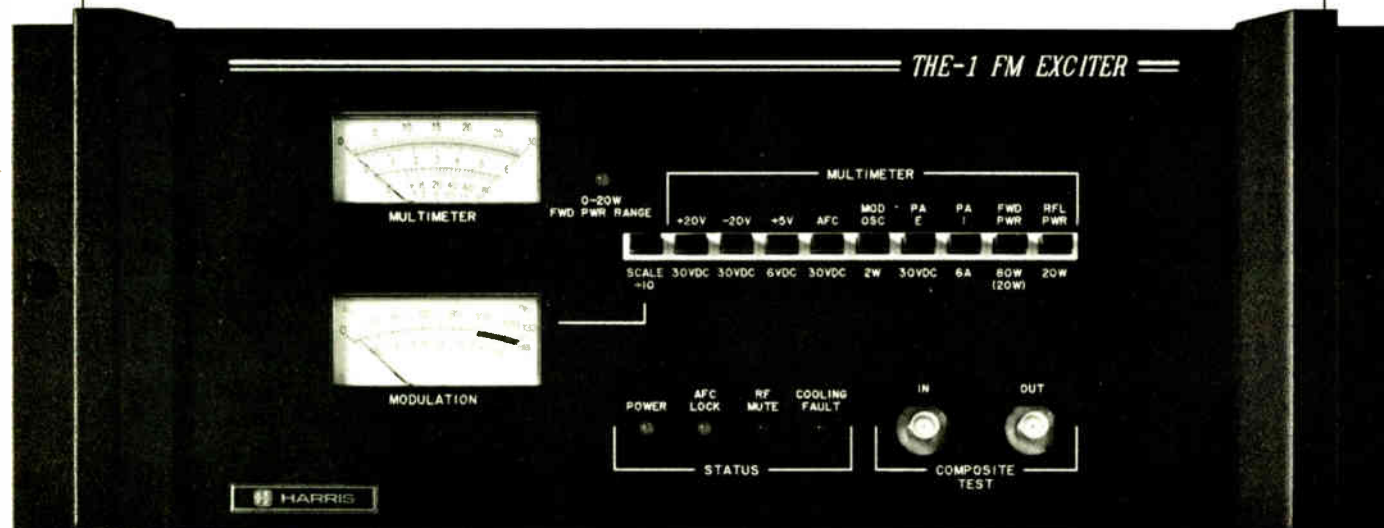

© Harris Corporation 1989

TRADE UP TO THE-1 FM EXCITER.

NFR Tests

(continued from page 7)

though NFR is incompatible with current AM stereo systems, this would be a moot point if it can be proved that a stereo composite signal can be frequency modulated on the standard broadcast band, he said.

When asked why WQYK applied for the experimental authorization, Berry said it was to help AM compete with FM. "AM stations need help. Amplitude modulation is a waste of time. While NRSC is going to improve things, it's not going to correct the basic problem, which is impulse noise," Berry explained.

According to Yazell, the advantages of NFR include higher audio fidelity, less noise and less interference. In addition, he believes it could eventually eliminate many directional antenna systems and possibly allow nighttime service for most daytime stations.

Licensed to Seffner-Tampa, WQYK operates on 1010 kHz with a daytime power of 50 kW and night power of 5 kW. The station uses a directional pattern both day and night. WQYK is owned by Infinity Broadcasting Corp.

In response to some skeptics of the system, Yazell replied, "Everything we will be doing has been done before."

For information on WQYK, contact Frank Berry at 813-689-8185. Contact George Yazell at 813-682-2270.

Paul Rebmann is CE of WEZY-FM/WLKF-AM, Lakeland, FL.

Techniques for Stereo Miking

by Bruce Bartlett

Elkhart IN In the 8 November 1989 installment of *Line Out*, we covered coincident-pair stereo miking. Such a technique, or any stereo miking method, is useful when you need to record or broadcast an orchestra, string quartet, or

LINE OUT

pipe organ. In this month's column we'll look at spaced-pair and near-coincident methods.

The spaced-pair stereo miking technique uses two microphones placed several feet apart, aiming straight ahead toward the musical ensemble (as in Figure 1).

The mics can have any polar pattern, but the omnidirectional pattern is most popular for this method. The greater the spacing between microphones, the greater the stereo spread.

The essentials

Let's explain how this method works. Instruments in the center of the ensemble produce an identical signal from each microphone. During playback of this recording, a phantom image of the center instruments is heard midway between the stereo pair of loudspeakers.

If an instrument is off-center, it is closer to one mic than the other, so its sound reaches the closer microphone before it reaches the other one. Consequently, the microphones produce approximately an identical signal, except that one mic signal is delayed with respect to the other.

If you send an identical signal to two stereo speakers with one channel delayed, the sound image shifts off center. With a spaced-pair recording, off-center instruments produce a delay in one mic channel, so they are reproduced off center.

The spaced-pair array codes instrument positions into time differences between channels. During playback, the brain decodes these time differences back into corresponding image locations.

It takes only one to two milliseconds of delay to shift an image all the way to one speaker. So, if we want the right side of the orchestra to be reproduced at the right speaker, its sound must arrive at the right mic about 1 to 2 milliseconds before it reaches the left mic.

In other words, the mics should be spaced about two to three feet apart, because this spacing produces the appropriate delay to place right-side instruments at the right speaker.

Instruments part of the way off center produce interchannel delays less than one to two milliseconds, so they are reproduced part-way off center.

If the spacing between mics is, say, 12 feet, then instruments slightly off center produce interchannel delays greater than one millisecond, which places their images at the left or right speaker. This could be called an "exaggerated separation" or "ping pong" effect.

On the other hand, if the mics are too close together, the delays produced will be inadequate to provide much stereo spread. In addition, the mics will tend

to both channels. That way, the ensemble is recorded with a good balance and the stereo spread is not exaggerated.

The spaced-pair method tends to make off-center images relatively unfocused or hard-to-localize, for this reason: spaced-microphone recordings have time differences between channels and stereo images produced solely by time differences are unfocused.

Centered instruments still are heard clearly in the center, but off-center instruments are difficult to pinpoint between speakers. This method is useful if you prefer the sonic images to be diffuse, rather than sharply focused (say, for a blended effect).

Getting warmth from space

There's another problem with spaced microphones. The large time differences between channels correspond to gross phase differences between channels.

Out-of-phase, low-frequency signals can cause excessive vertical modulation of the record groove, making records difficult to cut unless the cutting level or stereo separation is reduced. In addition, combining both mics to mono sometimes causes phase cancellations of various frequencies, which may or may not be audible.

There is an advantage with spaced miking, however. Spaced microphones

(continued on page 27)

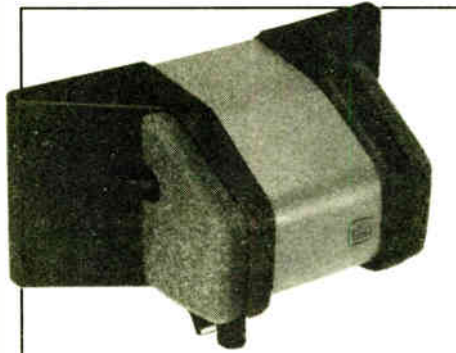

The Crown SASS-P™ Stereo microphone

to favor the center of the ensemble because the mics are closest to the center instruments.

So we need to place the mics about 10 or 12 feet apart to record a good musical balance, but such a spacing results in exaggerated separation. One solution is to place a third microphone midway between the outer pair and mix its output

DIGITAL DEDICATION.

The Sony PCM-3202 digital audio recorder allows you to maintain the digital integrity of your source material while providing splice-editing capability at a most affordable price.

To find out more, contact the Sony Professional Audio Office nearest you:
East: (201) 368-5185
West: (818) 841-8711
South: (615) 883-8140
Central: (312) 773-6001

PCM-3202

- TWIN-DASH 1/4" two-channel digital format • Up to 95 minutes recording (12.5" reel, at 48kHz) • 16-bit microprocessor to manage tape transport functions • Built-in splicing block
- Switchable 48kHz and 44.1kHz sampling frequencies • AES/EBU and SDIF-2 digital I/O ports • Built-in monitor speaker and headphone amp • Built-in 10-key locator

SONY
PROFESSIONAL AUDIO

Sony Communications Products Company,
1600 Queen Anne Rd., Teaneck, N.J. 07666
© 1989 Sony Corporation of America.
Sony is a registered trademark of Sony

GET IT RIGHT
GET IT FROM ALLIED

PUZZLED ABOUT SYSTEMS?

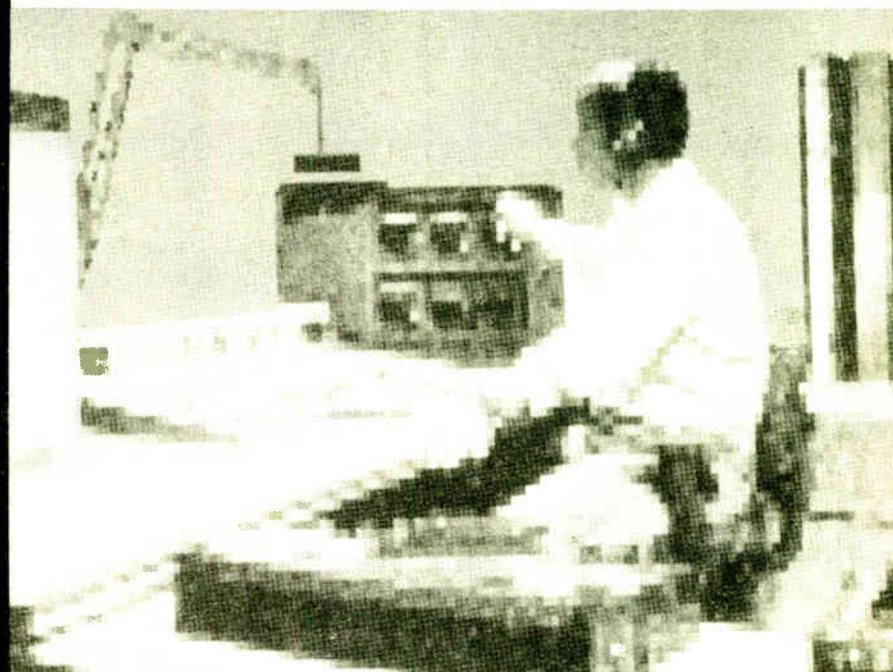

Allied is the ANSWER — tailored services to meet your needs and budget — specialists to bring your systems plans into REALITY — that's us!!

ALLIED
BROADCAST SYSTEMS
A HARRIS COMPANY

714-752-6664

4500 CAMPUS DR. • SUITE 202 • NEWPORT BEACH, CA 92660

© 1990 HARRIS/ALLIED

Avoid Fines by DCO Log Review

by Harold Hallikainen

San Luis Obispo CA In December, the FCC sent a letter to Modulation Sciences indicating that if their modulation monitoring product (the ModMinder™) meets the requirements of FCC rule 73.332 (deleted in July 1983), the monitor is satisfactory for determining compliance with the current modulation requirements.

There are no existing rules regarding modulation monitors, but there is the requirement of 73.1570(b)(2) that "total modulation must not exceed 100% on

peaks of frequent recurrence referenced to 75 kHz." There is no definition of a peak (can we throw out those less than

INSIGHT ON RULES

1 mS, as allowed by the deleted 73.332(d)(4)(i)?). There is no definition of "frequent recurrence."

Of course, frequent recurrence was defined under the ATS rules as 10 peaks in one minute, but that rule has been deleted (73.342(b)(3)). When the FCC Rules impose a limit, they should give a technique for measuring that parameter.

For example, the new AM emission limitations of 73.44 (NRSC-2) tell how the measurements are to be made. This is great! However, in many of the existing regulations, it would be easy to argue that no violation exists because of different methods of measuring a parameter.

Lack of clarity

There is no published "right way" to measure the parameter. In many cases, the Commission may have an internal policy on how the measurements are made, but it would appear unfair to expect someone to comply with a law that is unpublished (a secret law).

Another example of this lack of clarity in the Rules regards remote control failsafe. Ah ha! Failsafe was eliminated in the deregulation of remote control, right?

However, the Commission will point to the 73.1410(e) requirement to immediately terminate operation in an interference causing condition. The lack of some "failsafe" method of ensuring that you have the capability to immediately terminate operation may get you a violation notice.

Under the old rules, the Commission

program audio is specifically allowed in the FCC clarification of the remote control rules (PN88-194), but, again, no time delay is given.

This station used the 10 minute timeout because the classical programming they run involves several minutes of very low level audio. Again, the rules are unclear. I hope the FCC is more clear in their future rulemakings.

To help stations determine FCC interpretation of rules, I have compiled a listing (about 25 pages) of all the 1988 violation notices (about 2500 pages) the

... the vast majority of (violation notices) would not have been issued if the Chief Operator was doing the job correctly.

accepted a "minute or so" delay in the shutdown, although this was not specified in the rules. In a letter from the FCC (6 February 1987), I was told that a once-an-hour handshake between the control point and the transmitter site would not satisfy 73.1410(e), although the current rules do not specify how often the control capability must be verified.

A recent letter from a reader said that an FCC inspector "thought long and hard" about a 10 minute timeout on a "loss of program audio" failsafe. Loss of

FCC sent me in a Freedom of Information Act request.

This list tells the section violated, the call of the station, the fine, the reduced fine and comments on the violation. The comments are my comments on what the violation was and how the station responded. Call me for a copy. I have recently filed another FOIA request for the 1989 violation notices.

Review those logs!

In my review of violation notices, I've found that the vast majority of them would not have been issued if the Chief Operator was doing the job correctly. Just about all the violations should have been caught in the weekly log review by the Chief Operator, as required by 73.1870(c)(3). Let's review some items to watch for in your log review.

A daily inspection of tower lighting is required by 17.47. This may be a visual inspection or may be observation of an indicator that properly registers the fail-

(continued on page 37)

WHAT
MAKES
AUDIOPAK
THE CART
YOU CAN
COUNT
ON?



CONSISTENCY We've been using AA-4s for five years, and have had nothing but success with them. They've been very good to us."

Skip Voros, C.E.
WMVP/WLUM, Milwaukee, WI

Only one cart meets every demand broadcasters place on it: Audiopak. To find out why, call (800) 522-CART.

CART AFTER
CART.

audiopak

P.O. Box 3100 • Winchester, VA 22601
Tel (800) 522-CART or
(703) 667-8125 • Fax (703) 667-6379

Circle 19 On Reader Service Card

THE VIGILANTE IS GONNA' GET YOU!

...So why not get it first? The "Vigilante" Multiband Limiter from Cutting Edge Technologies lets you capture the edge from your competition with:

- ⚡ Increased competitive loudness
- ⚡ No processing artifacts
- ⚡ No loss of mid-band and presence frequencies
- ⚡ Superior loudness clipper circuitry, virtually distortion free

Don't get left behind.

Call to find out more about the "Vigilante" Multiband Limiter:

(216) 241-EDGE
FAX: (216) 621-2801

 CUTTING EDGE TECHNOLOGIES, INC • 2501 West 3rd Street • Cleveland, Ohio 44113

Circle 60 On Reader Service Card

EXECUTIVE DECISION MAKERS



DO YOU KNOW YOUR MARKET? YOUR COMPETITION DOES!

Are Your Contours Really Where You Think They Are?
Are Your Sales/Marketing People Market Oriented?
Can You Target Your Ethnic/Demographic Markets?
Do You Know Where Your Signal May Be Marginal?
Do You Have A Special Mapping Requirement?

DATAWORLD MAPS CAN WORK FOR YOU

MAP OPTIONS

- SHADOWING (TERRAIN SHIELDING)
- POPULATION DENSITY
- CONTOUR COVERAGE
- POWER DENSITY
- COMPOSITES
- SPECIALS

dataworld[®]
A Service of DW, Inc.

P.O. Box 30730, Bethesda, Maryland 20814
Fax (301) 656-5341
(301) 652-8822 (800) 368-5754

Circle 44 On Reader Service Card

Dolby SR improves the medium for your message.

TAPE RECORDERS

Dolby SR provides the performance attributed to digital systems while maintaining such analog virtues as economy, editing ease, and tape interchange.

CARTS

Along with their familiar ruggedness and all-around utility, carts with Dolby SR capture the full dynamics of all your source material, digital or analog.

1-INCH VTR'S

With Dolby SR, video can sound as good as it looks. Signal purity is maintained through the multiple tape generations necessary in today's post-production techniques.



DISCRETE STL'S AND RPU'S

Dolby SR improves headroom and lowers noise, while suppressing the effects of interference and fade.

TV STL AUDIO SUB-CARRIERS

With Dolby SR, there's no need to re-allocate subcarrier frequencies or replace existing equipment in order to deliver high quality audio to the transmitter.

SATELLITE AUDIO

Dolby SR improves analog channels without audible side effects yielding performance rivaling digital systems.

Listeners today expect better sound wherever they go — at home, at the movies, in the car. To keep up with their expectations, you need Dolby SR. Two channels, with the compact, easy-to-operate Dolby Model 363 (shown). Or up to 24 channels, with Dolby Laboratories' multitrack products.

Dolby SR dramatically reduces noise, increases headroom, and lowers distortion from initial production to final transmission. That means you can deliver your message today with the clarity you've been expecting from the technology of tomorrow.

NEW NEW NEW

SERIES CONSOLES

S - \$6,499 /18 CHANNELS - \$8,893



24-2248

FEATURES

- Totally Modular Console-Input modules, Output modules, Option modules
 - Ease of Service
 - Ease of Installation
 - Ease of Expansion
- Three Mainframe Sizes-8 channels, 18 channels, 28 channels
 - Full Metering
 - Timer on All models
 - Talkback to "2" studios
- Ultrahigh Quality Construction and design
 - Penny and Giles 3000 Series slide faders
 - VCA's
 - ITT Schadow switches
 - Gold connectors-IC's socketed-regulated power supply
- 3 Stereo Output Buses
- 2 Internal Mix-minus Buses for 'Telephone'
- Option Modules-D.A.'s, Mono Mixes, Remote Selectors, Etc.
- Comprehensive Logic system
 - Start and stop sources by isolated internal reed relays
 - Remote channel On and Off control with Tally lamps for turrets
 - Flashing OFF switches for cart machine status
 - Three muting buses for Control room and two studios
 - Timer reset selectable on each module
 - Monitor DIM function during cue and talkback

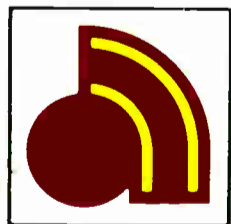

arrakis
SYSTEMS, INC.

**NEW
NEW
NEW
NEW
NEW**

**NEW
NEW
NEW**

An Introduction to Construction

by Frank Miller

Henderson NV Welcome to a new column called *Project Notebook*. The purpose is to present construction articles on audio equipment that is useful and easy to construct. I have had over 20 years experience in building audio products.

In these construction articles there will be a description of the purpose of the product, how to use it in a system or by itself (depending on the product).

There will also be a complete schematic, printed circuit board layout,

component overlay (for inserting components), sheet metal layout, front and rear panel layouts and theory of operation. When specialized components are used supply sources will be listed, with complete details for ordering.

The construction articles will be very complete; the devices can be built with nothing more than some knowledge of electronics and good construction techniques. I will assume that you have built some other projects from time to time and basically know what to do.

The projects are aimed at obtaining better quality audio products and keep-

ing costs down. The quality will be high and employ the latest technology available for a modest cost.

Because digital technology is coming into our everyday life, we will explore the

PROJECT NOTEBOOK

technology as it can be used in professional audio.

For example, the compact disc is the playback medium of the present and

Be prepared.

For the
first real
improvement
in AM sound
in more than
a decade.



The future offers real promise for AM radio. NRSC AM radios are almost here, factory-installed in new cars. Soon, home stereos and portable sets will also be NRSC-equipped.

NRSC (National Radio Systems Committee) has created a voluntary national transmission standard that makes wideband high-fidelity AM radios practical. As broadcasters adopt the NRSC standard, receiver manufacturers can extend and flatten their frequency response without risk of increasing the audibility of interference.

Is your station prepared?

The 9100B NRSC-standard OPTIMOD-AM® is the first choice of AM stations concerned about improving their sound to compete with FM. OPTIMOD-AM sounds great on both the new NRSC receivers *and* on the millions of narrow-band receivers already in the field that will be in use for years to come.

When replacing older-style processors with OPTIMOD-AM, stations experience a significant increase in coverage area. And when replacing any processor, stations experience a dramatic improvement in sound quality, on both *voice* and *music*, with no sacrifice of loudness.

Superior sound is an important part of an overall strategy to increase ratings and profits. With OPTIMOD-AM, your announcers' voices will have presence and impact, while still sounding very clean. Music will have real bass, with punch and warmth, not boom. The highs will seem to open up. And loudness and tonal balance will be consistent from source to source.

OPTIMOD-AM can be configured to operate optimally in mono, C-QUAM® stereo, or Kahn stereo. Mono units can be field-upgraded later to stereo by simply plugging in additional cards.

Be prepared. Call your Orban Broadcast Products Dealer for more information on OPTIMOD-AM 9100B, or call us direct.

orban

a division of AKG Acoustics, Inc.

645 Bryant St., San Francisco, California 94107 USA

Telex 17-1480 FAX (415) 957-1070

Telephone (415) 957-1067 or (800) 227-4498

Circle 69 On Reader Service Card

World Radio History

Newark Electronics
4801 N. Ravenswood Ave.
Chicago, IL 60640-4496
312-784-5100
FAX: 312-784-5100, ext. 3107
Minimum order \$25
Visa, MC & COD

Digi-Key Corp.
701 Brooks Ave. South
PO Box 677
Thief River Falls, MN 56701-0677
218-681-6674 1-800-344-4539
FAX: 218-681-3380
No minimum order
Visa, MC & COD

Mouser Electronics
National Distribution Center
2401 HWY 287
North Mansfield, TX 76063
817-483 4422 1-800-346-6873 (in-
cludes Canada) FAX: 817-483-0931
Minimum order \$25 All major
credit cards & COD

Circuit Specialists, Inc.
PO Box 3047
Scottsdale, AZ 85271-3047
602-966-0764 1-800-528-1417
FAX: 602-967-2539
Minimum order \$15
Visa, MC & COD

DC Electronics
PO Box 3203
Scottsdale, AZ 85271-3203
602-945-7736 1-800-423-0070
FAX: 602-994-1707
Minimum order \$15
Visa, MC & COD

Radio Shack Stores
Consult your local white pages
No minimum order All major
credit cards

Greenlee Tools
See Newark Electronics &
Mouser Electronics

Roper-Whitney Tools
Keystone Electronics
31-07 20th Road Astoria,
NY 11105-2017
718-956-8900 1-800-221-5510
FAX: 718-956-9040
Minimum order \$200.00 (sold
through distributors COD) Punch
Set Model 1330 about \$66

DAT, which I expect to gain popularity in 1990, will be the future recording media for portable high quality recording.

These technologies will demand better quality audio components in your systems. With this in mind, the upcoming series of construction articles will help you upgrade your audio systems without great expense.

Overview of articles

Since professional audio equipment is so expensive, many of us purchase high-end consumer equipment and must adapt it to the professional equipment that we own. This usually means that the level and impedances are wrong and must be fixed.

The first article will be on a device that can be used in almost any system. This box has many names—it is usually called a Semi-Pro to Pro Box.

Essentially it takes unbalanced low level audio and converts it to the professional and balanced audio. Some

(continued on page 29)

The Ins and Outs of Stereo Mic Setups

(continued from page 21)

are said to provide a "warm" sense of ambience, in which concert-hall reverberation seems to surround the instruments and, sometimes, the listener.

Here's why: The two channels of recorded reverberant sound are incoherent; that is, they have random phase relationships. Incoherent signals from stereo loudspeakers sound diffuse and spacious.

Because reverberation is picked up and reproduced incoherently by spaced microphones, it sounds diffuse and spacious. The simulated spaciousness caused by the "phasiness" is not necessarily realistic, but

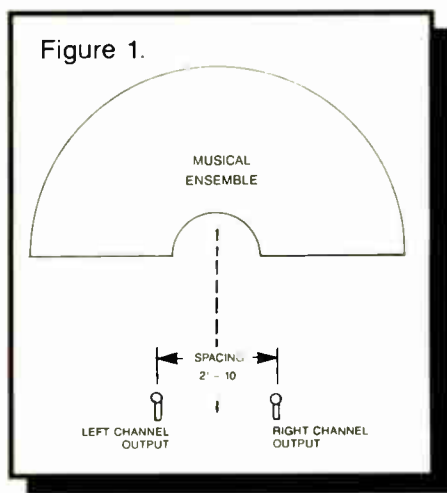

it is pleasant to many listeners.

Another advantage of the spaced-microphone technique is the ability to use omnidirectional microphones. An omnidirectional condenser microphone has more-extended low-frequency response than a unidirectional condenser microphone.

Near-coincident technique

As shown in Figure 2, the near-coincident technique uses two directional microphones angled apart, with their grilles horizontally spaced a few inches apart. Even a few inches of spacing increases the stereo spread and adds a sense of ambient "warmth" or "air" to the recording. The greater the angle or spacing between mics, the greater the stereo spread.

Here's how this method works. Angling directional mics produces level differences between channels; spacing mics produces time differences. The interchannel level differences and time differences combine to create the stereo effect.

If the angling or spacing is too great, exaggerated separation results. If the angling or spacing is too small, the result is a narrow stereo spread.

The most common example of the near-coincident method is the ORTF system. ORTF stands for Office de Radio-diffusion Television Francaise—French Broadcasting Network. The system uses two cardioids angled 110° apart and spaced seven inches (17 cm) apart horizontally.

This method tends to provide accurate localization. That is, instruments at the sides of the orchestra are reproduced at or very near the speakers, and instruments half-way to one side tend to be reproduced half-way to one side.

There are two microphones currently available that employ the near-coincident philosophy. One is the Schoeps MSTC 34, 44 and 54, which uses two cardioid condenser capsules permanently set in the ORTF configuration. The other is the Crown SASS™-P

Spaced microphones are said to provide a "warm" sense of ambience ...

(Figure 3), which uses two ear-spaced Pressure Zone Microphones® mounted on boundaries that are angled apart.

The angled boundaries make directional polar patterns (at mid-to-high frequencies) aiming left and right. According to the manufacturer, the microphone is mono-compatible due to a foam barrier between the capsules that prevents acoustic crosstalk. The SASS-B is a similarly shaped boundary mount for Bruel & Kjaer 4006 studio microphones, which offer 10 dB less noise.

Placement

Once you've decided on your stereo miking method, you're ready to place the microphone pair relative to the musical ensemble. A good starting spot is 12 feet behind the conductor, 14 feet high on a stand or hung from the ceiling. One radio station placed a spaced pair of mics on stands sticking out from the balcony.

You want a tasteful blend of direct sound from the orchestra and ambient sound from the hall. If the sound is too distant or muddy, move the microphone pair closer to the ensemble. Do the opposite if the sound is too close, detailed, or edgy.

If the stereo spread is too narrow, increase the angle or spacing between

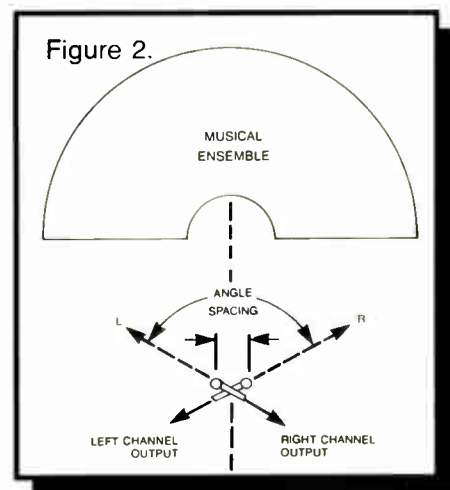

microphones until the reproduced orchestra spreads from speaker to speaker. If you hear exaggerated separation, reduce the angle or spacing between mics.

We've examined several types of stereo miking. Each method has its own advantages and disadvantages. Which method you choose depends on the sonic compromises you are willing to make.

■ ■ ■

Bruce Bartlett is a microphone project engineer and technical writer with Crown International. He can be reached at 219-294-8000.

High Octane Fuel..

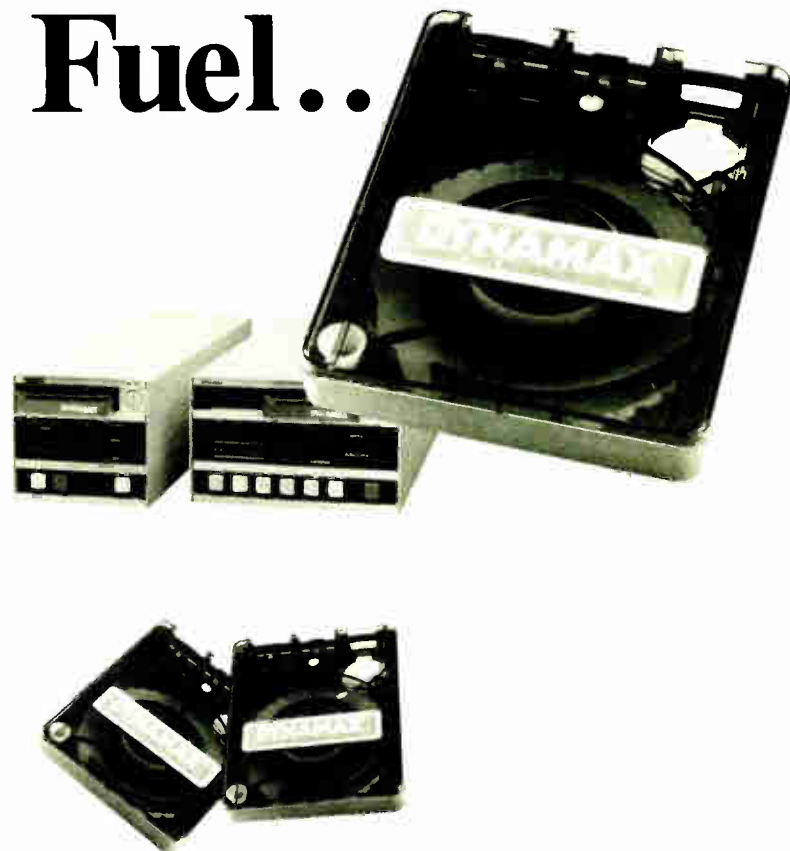

...For High Performance Audio.

Race cars are highly dependent on the fuel that they use, and special high octane blends are formulated to maximize their performance.

The same is true with cart machines. If you're not using the right audio cartridge, your machines will not provide the maximum performance required in today's digital environment. That's why Fidelipac developed the Dynamax Cobalt cartridge.

Only Dynamax has a unique Cobalt tape formulation that offers greater high frequency response and headroom, coupled with a shell design that ensures superior phase uniformity, reduced flutter, and increased play life.

Get the maximum performance out of your machines. Fill up with a load of Dynamax Cobalt carts from BSW.

BSW®

BROADCAST SUPPLY WEST

America's Full-Time Broadcast Supplier

1-800-426-8434

ORDERS • INFORMATION • SPECIFICATIONS
BSW • 7012 27th Street W • Tacoma, WA 98466 • FAX 206-565-8114

College Radio and Commercial Origins

by George Riggins

Culver City CA Department of incidental information: it seems that navigating with the aid of commercial broadcasting stations is not dead.

A consultant in the midsection of the US reports that he still does a lot of his cross-country navigation by using commercial stations on his route. It is also another way of checking on what is happening at the station where he is heading and to hear what the signal is doing.



As for WWII, a call from George Jacobs of Washington, DC reported that when he was a navigator on B-17s and flying across the Atlantic, he used a station in the south of England at about 200 kc for the eastbound trip and WOR on the westbound flight.

George (W3ASK) reported that he could get a reliable heading on WOR about halfway across and that the destination was usually the base not too far

from the WOR transmitter location. George also reports as to still having a copy of the old tech manual listing the stations of the WWII era.

College broadcasting

To continue with the educational process associated with radio in the formative years, a list of college stations was made using the Radio Station Treasury, 1900-1946, by Tom Kneitel. The year 1935 was used as the base year and there were 38 stations, by my count, that were recognizable as being educational stations, including two in Canada.

By 1940 six had dropped out, leaving 32, with one in Canada—CFRC, Kingston, Ontario. CFRC was listed as being part of Queens University in 1936. The 1940 listing did not mention CFRC, but the 1946 listing does include the call, although not specifying whether it was a commercial call or an educational station.

A paper written by Rick Jensen, of Texas A&M in February 1984 was sent to me by Bill Hicks of WTAW, College Station, TX. It gives an interesting history of WTAW when it was licensed to Texas A&M University. The station's history starts in 1911 as one of two stations placed in the Texas university system—the other being at the University of Texas, Austin.

(continued on page 37)

60 YEARS AGO

WORTH THINKING OVER

TELEVISION is still an interesting subject for experiment—and this in face of recent public demonstrations, which again proved that this branch of science and adventuring has a long way to go before it can become a fixed commercial feature in the radio field. The more the ordinary man discovers about the halting advance of television the more he is urged to be satisfied with radio as it is and to lay in his radio supplies for the winter.

Amos 'n' Andy Sign Long-Term Renewal

The National Broadcasting Company, as their exclusive agent, Amos 'n' Andy has signed a long-time contract for their services with the Pepsodent Company of Chicago, present sponsors of their program.

That announcement was made as Charles J. Correll and Freeman Gosden ended their first year with NBC and the tooth paste manufacturers. The contract is said to call for a salary on a sliding scale over a period of five years, netting Correll and Gosden the largest amount ever paid radio entertainers. In addition to this, the Pepsodent Company paid Correll and Gosden a substantial bonus this year above their salary.

Vreeland Sues Maker Of Majestic Receivers

The Vreeland Corporation, of New York City, has filed suit against the Grigsby-Grunow Co., of Chicago, manufacturers of Majestic radio receiving sets, for alleged infringement of the Vreeland band selector patents, in the United States District Court of Delaware. The Robelin Piano Company is named as co-defendant. Samuel E. Darby of New York appears as counsel for the plaintiff.

The bill of complaint specifies patents numbers 1,725,433, band receiving system; 1,730,987, variable band amplifiers, and 1,749,930, variable circuit element for radio receiving sets, as being infringed. This group of patents covers the band selector system invented by Dr. Frederick K. Vreeland, president of the Vreeland Corporation.

It is claimed for the band selector system that it selects or segregates the full band of frequencies sent out by the broadcasting station, whereas, according to Dr. Vreeland, the conventional tuned radio frequency system cuts the side bands and impairs tone quality. It is also claimed for the band selector system that it solves the problem of selectivity and eliminates cross talk. Cross talk is the modulation of a weak signal by a powerful local station which causes the same station to tune in at several points on the dial of a radio set.

—Reprinted from *Radio World*
September 20, 1930

Editor's note: The **RW** of old, printed for a time in the 1920s and 1930s and today's **RW** are unrelated except in name.

Top talk show producers

by it.

Ask the talk radio leaders which audio delay they rely on for obscenity protection. The Eventide BD980 Broadcast Audio Delay is the industry standard because it sets the performance standards: Audio bandwidth, stereo separation and phase integrity, distortion and noise, convenience, and reliability. You can even use the BD980 in the production room to time-compress stereo commercials.

For obscenity protection, the BD980 gives you up to 10 seconds to intercept a "no-no." The moment you *Dump* to real time, the sophisticated deglitched *Catch Up* function starts rebuilding delay protection automatically and virtually inaudibly.

How often do you need to get in and out of delay? How fast? It's easy with the BD980's

exclusive *Wait & Exit* feature. Now even the busiest morning man can get in and out of delay for traffic reports, news or other live air-cued sources—without interrupting the flow of the show.

If you broadcast talk that sometimes walks the line, make sure your safety net is the best: The BD980 Broadcast Audio Delay. Call your broadcast distributor. Without delay.

Eventide
the next step



ONE ALSAN WAY • LITTLE FERRY, NJ 07643 • TEL: 201-641-1200 • FAX: 201-641-1640

An Overview of Audio Tinkering

(continued from page 26)

such boxes only go one way, but we will describe a box that will be useful in both directions. It will be able to handle a stereo record and playback function and will be all-electronic in design and ready for digital audio equipment.

After that I'll describe a power amplifier that can be used for monitor purposes in your studio. The power will be a modest 35 watts per channel with inputs tailored for use in both professional and semi-professional systems. Other items will be discussed later as more time permits.

You will need some basic items for the construction process. The basic mechanical tools are screwdrivers (both Phillips and slotted types—two sizes of each), small long-nose pliers, small diagonal cutters, wire strippers, a miniature blade knife, a small soldering iron (15-25 watt type with small tip for PC board construction), thin gauge rosin solder (.032"

Your local electronics store is the best source for common parts.

for PC boards and .050" for mechanical type components). Most of these items can be purchased at your local electronics store or a Radio Shack store.

Some additional tools and accessories that you might find useful in construction and debugging of these projects are a VOM (at least 20,000 ohms/volt) or a digital multimeter, an audio generator, frequency counter, total harmonic analyzer, power supply and an oscilloscope.

These items are harder to find, but they can be very useful in other areas of your work. They can be found in mail order catalogs and your local electronics store.

PCs and metal work

If you are planning to construct your own printed circuit boards, you will need other types of supplies. The articles in this series will include the printed circuit layout in full size (where space is available) or to scale.

When full-size is included, you will have to make a clear film positive or a negative to make the board. The additional supplies can be obtained from your local electronics store or from Datak or Kepro Systems. If you prefer not to make them, I will offer them at a modest cost.

If you are planning to do your own metal work, you will need a small hand drill with a complete set of drill bits. Actually, a small drill press would be a better choice (they can be purchased for about \$80 at a discount hardware store).

Other tools for the job include a set of Greenlee chassis punches (for larger round holes), a set of files (for small round holes 1/32" to 9/32"), a hand punch (Roper Whitney), a metal nibbling tool for cutting square or rectangular holes in metal, and a tapered reamer.

If you prefer not to make the sheet metal portion of the project, I will again

supply it a modest cost.

The front and rear panels of the metal work can be silk screened with the layout supplied in the article, or you may use instant lettering (the rub-on kind).

Sources

There are several sources of lettering available: Radio Shack, Datak and Letraset (available in art supply stores). When using instant lettering I suggest that you use a special spray after putting the lettering on the metal to protect it from use.

There are several good sources for

electronic components for building your projects. Your local electronics store is the best source for the common parts. Radio Shack stocks the common resistors, capacitors, ICs, switches, etc.

When you need other types of parts, I would recommend obtaining these companies' catalogs: Digi-Key, Mouser Electronics, Circuit Specialists, Newark Electronics and DC Electronics. The addresses are listed in the accompanying box.

I have tried all of these sources; they sell small quantities at affordable prices with reasonable minimum orders. It

would be a good idea to call or write these sources and ask for their free catalogs to keep in your library.

Your input as readers will be very valuable in these articles, I would like to know what kind of pieces of audio equipment you would like to see constructed. Your ideas are a great resource as to what people really need in the way of audio equipment.

■ ■ ■

Frank Miller is an audio consultant who has 23 years of experience in the manufacturing side of the industry. He can be reached at Sescom at 702-565-3400.

When you need us, we'll be there.

It's dawn. Your farm man is giving the livestock and asparagus quotations. Then, poof!

You're off the air.

If you're an Audio Broadcast Group customer anywhere in the U.S., just call our toll-free number.

Twenty-four hours a day, you'll get a live person for technical advice or assistance.

We'll do everything we can to solve your problem, on-the-spot and without charge.

Know any other component distributor or systems designer with 24-hour service?

It's another reason The Audio Broadcast Group stands ahead of its competition.

And that's just part of our service story. We'll be happy to tell you the rest. Give us a toll-free call.

 **AUDIO**
broadcast group inc.
2342 S. Division Avenue
Grand Rapids, Michigan 49507-3087
1-800-999-9281



Everyone has an opinion
about ModMinder.

Here's
the one
that
counts.

FEDERAL COMMUNICATIONS COMMISSION
WASHINGTON, D.C. 20554

DEC 4 1989

Modulation Sciences Inc.
115 Myrtle Avenue
Brooklyn, NY 11201

Attention: Mr. Eric Small

Dear Mr. Small:

I was recently contacted by your attorney, Mr. Harry Cole, concerning Modulation Sciences' "Modminder" FM broadcasting modulation monitor. I understand your company has received several inquiries about the validity of FM modulation measurements made with this instrument.

Commission rules currently contain no requirements for FM modulation monitors. Technical specifications and other performance requirements did exist until July 1983 when the Commission, by Report and Order in MM Docket 81-698, deleted them as unnecessary. While the requirements for modulation monitors were deleted, the Commission retained the standards governing FM modulation. See Section 73.1570 of the current Rules.

Mr. Cole stated that the Modminder is designed to satisfy the pre-1983 technical requirements for FM modulation monitors. If the equipment does indeed meet the pre-1983 technical requirements (see the enclosed copy of former Section 73.332), I expect it would produce valid readings of FM modulation. Equipment meeting the pre-1983 requirements is satisfactory for determining compliance with the current FM modulation requirements.

Please let me know if I may be of any further assistance.

Sincerely,

Thomas P. Stanley
Thomas P. Stanley
Chief Engineer

Enclosure

It's only been a short while since we introduced ModMinder™ and changed the rules of the processing wars. But it seems everyone in radio has expressed an opinion about this revolutionary digital modulation measurement instrument.

Here's the one that really matters. This letter from Dr. Thomas Stanley, Chief of the FCC's Office of Engineering and Technology, confirms that the ModMinder takes "...valid readings of FM modulation. Equipment meeting the pre-1983 requirements is satisfactory for determining compliance with

the current FM modulation requirements."

We designed ModMinder to meet the pre-1983 requirements. And to measure FM modulation like nothing else, pre- or post-1983. For more information on how ModMinder can help you be louder and cleaner—and legal—call Modulation Sciences at 800-826-2603, toll free.

modulation sciences, inc.

115 Myrtle Avenue • Brooklyn, NY 11201 • Tel 718-625-7333 • Toll Free 800-826-2603 • Fax 718-260-8286

Circle 31 On Reader Service Card

World Radio History

How to Hot Rod a Processor

by John Shepler

Rockford IL Sometimes you just have to roll your own. This is especially true when you are striving to create that unique sound.

Q-TIPS

Today's major processors are more complex than the ones we drove into battle 10 and 20 years ago. Most of that complexity, though, results from doing more within a single box. The basic principles of gain riding, gating, compression, limiting and clipping remain unchanged from the days of vacuum tube processors. It's the circuit designs and the combination of functions that are unique.

I hope you're not overly intimidated by what goes on inside those hot proces-

sors. A lot of processing magic is made from things that you can do yourself.

You can mix and match boxes at will. You can even get inside your old dinosaur gear and rev it up to compete with that better funded team across town. Or, you may buy one of the biggies for the primary audio chain and dabble with something different in production or for the mics.

This column goes into some of the basic differences in processing and how you can build or modify equipment to meet your own needs.

What to look for inside

There are frequency modifier boxes, such as equalizers, de-essers and reverbs. There are also amplitude modifiers such as gain riders, compressors and limiters.

Amplitude and frequency are the two variables you have to work with in audio. Some processors work only on fre-

quency or amplitude. Some do both, either as separate functions or combined in the same circuit. For simplicity, we'll consider these to be separate functions.

Also, in this column I'll only tackle the amplitude modifiers. These are the trickiest to deal with and are the ones that put the power into the signal.

Amplitude processing is done mostly

tages. We'll come back to clippers another day.

Today, we're going to peek inside a simple gain reduction processor. A gain reducer works exactly like a board operator riding gain. The operator watches the VU meter. When the level gets above 0 VU, the operator turns down the pot until the meter peaks at 0 VU again. If the level drops, the operator does just the opposite until the level is brought up to 0 VU.

One advantage of doing this electronically is that the processor will pay closer

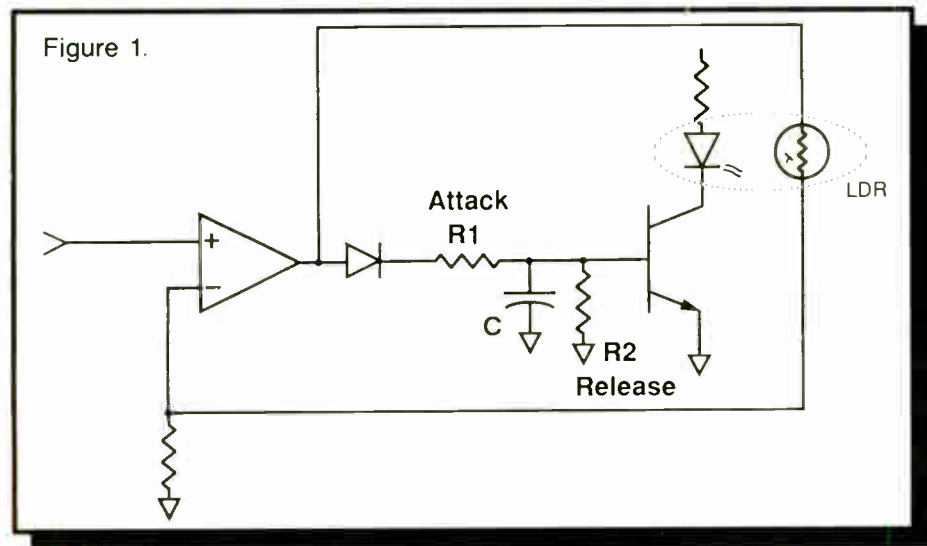

Figure 2.

Attack Time	Release Time	Processing Action
Slow	Slow	Gain Riding
Medium	Slow	Mic Processing
Medium	Medium	Compression
Fast	Medium	Limiting
Fast	Fast	Maximum Density

by two types of circuits: clipping and gain reduction. The simplest clipper is a pair of diodes connected back-to-back from signal to ground. Any voltage above the forward conduction threshold of about 0.7 volts will turn on the diodes and clip, or short out any higher vol-

attention to the levels than any board operator. A bigger advantage is that the processing action can be electronically set many times faster than anyone is capable of twisting a pot.

The two terms you need to know are (continued on page 34)



You can measure...
with the best monitor and the most accurate test set.

The FMM-2/FMS-2 series monitors provide an even greater degree of precision measurement than ever before... You can measure S/N below 90 dB, You can measure crosstalk below 85 dB, You can measure separations of better than 70 dB, You can measure frequency response to better than 0.25 dB, You can measure distortions to lower than 0.01%, and much more... Our uncluttered panels and autoranging voltmeters make these measurements a dream.

BELAR ELECTRONICS LABORATORY, INC.
CALL ARNO MEYER (215) 687-5550
LANCASTER AVENUE AT DORSET, DEVON, PENNSYLVANIA 19333
Call or write for more information on Belar AM, FM, Stereo, SCA and TV monitors.

GET IT RIGHT
GET IT FROM ALLIED

SATELLITE FOUNDATION BLOCKS

TO BETTER AUDIO —
AVAILABLE AT **ALLIED** —
YOUR AUDIO DOWNLINK
SPECIALIST WITH THE FINEST
GEAR AVAILABLE!

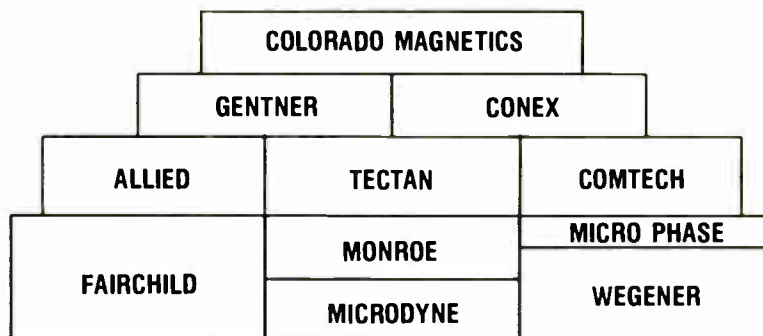

CALL JEFF OR JERRY TODAY FOR EXPERT ADVICE & PRICING

ALLIED SATELLITE EQUIPMENT
A HARRIS COMPANY

317-962-8596

3712 NATIONAL RD. WEST • P.O. BOX 1487 • RICHMOND, IN 47375
1990 HARRIS-ALLIED

A "Holistic" Digital Perspective

by Mel Lambert

Studio City CA From time to time, all of us need to take stock of where we think the radio broadcast industry is heading. As I have often stated, digital offers a broad spectrum of technical, creative and operational advantages.

I expect that virtually all major recording studios will be digital-capable within the next two to three years—in terms of both multitrack and mastering hardware—with post facilities lagging by maybe 12-18 months.

I predict that workstations, because of their higher initial costs, will become widely accepted in the audio-for-video and post markets sooner than in the traditional music-recording industry. (The fact that the majority of multichannel random-access recording and editing systems come complete with timecode-follow capability represents an immediate attraction to our film-and video-oriented brethren.)

Digital optimist

During a long and animated conversation I had recently with a chief engineer of a major-market AM/FM station, I was bestowed with the epithet of "digital optimist." While I don't consider myself such, I did have reason for a rapid indrawing of breath at his suggestion that in many applications around a

"typical" radio station, analog technology might offer a more cost-effective solution than digital.

In the main, I couldn't fault his back-of-an-envelope calculations. There really is still no getting away from the fact that, aside from CD players and one or two

DIGITAL DOMAIN

DAT machines, the majority of digital hardware has yet to offer us any financial breakthroughs—that good ol' economy of scale principle.

But, I offered, initial costs might be blinding us to the medium-and long-term impact of digital technology. Consider your current sources of broadcast audio material. The majority of classical, rock, jazz and other musical genres are now freely available on CD. (And yes, I realize that an increasing amount of vintage material has yet to be offered on CD, although the "Oldies but Goldies" categories from the record catalogs now offer some excellent compilations.)

Practically all of the major production music and sound effects libraries are now available on Compact Disc and represent a ready source of first-generation material for commercials, PSAs and other production tracks.

For field recording, the newer generation of battery-powered portable DAT machines offer outstanding audio quality, up to two hours of continuous recording on a single cassette, program IDs and high-speed cueing to any location.

While their current cost is typically between two and eight times that of a high-quality analog cassette deck—and up to twice that of a portable reel-to-reel machine—the quality improvement and operator convenience offered by DAT recorders should also be factored into the cost/benefits equation.

With so much pre-recorded and production sources now available in one

for integrating the various recording, editing and processing tasks we need to perform on the music, voice and sound effects elements that make up the program material.

A station chief or general manager needs to remember that, with digital, the whole is greater than the sum of its parts. On price factors alone, a standalone DAT recorder might not make a great deal of sense, especially if it isn't equipped to provide electronic editing.

But, considered as a source and mastering transport for a compact, flexible and user-friendly random-access editing workstation, the same DAT ma-

... the majority of digital hardware has yet to offer us any financial breakthroughs ...

digital format or another, there are sonic advantages to be had by keeping the material within the digital domain as much as possible.

Studio DAT machines are very competitive in price with analog reel-to-reel machines and, aside from razor-blade editing, represent a realistic alternative for most mastering and replay functions.

For mixing, a couple of passes through a conventional, high-quality production console shouldn't degrade the audio by any subjective amount. And for editing, there are several mid-priced systems designed to be controlled from a dedicated minicomputer, Macintosh or IBM PC workstation.

Being controlled from a central workstation, operation and systems configurations can be memorized and recalled for use at a later date, perhaps to add a different tag line to a commercial, or to re-edit a jingle package into :30 and :15 lengths from a master, or to shorten up and integrate a series of interviews for an end-of-year wrap-up feature.

But cost and operator flexibility represent only two of the many factors to be weighed in the analog-versus-digital equation. As I have mentioned before, the key to taking full advantage of digital is *connectivity*.

By their very nature, microprocessor-based recording, editing and processing systems are designed to be interconnected so that audio material can move freely from one function to another, entirely within the digital domain.

The digital gestalt

Currently, we are still missing some of the affordable building blocks necessary for the all-digital air and production studio of the near future.

Standardization also needs to make a few more strides in the direction of both simplifying and rationalizing the often intimidating collection of digital formats and connector types we now encounter in the studio.

For input/output, high-precision analog-to-digital converters—with and without ultra-precision mic pre-amplifiers—plus digital-to-analog converters would ensure faultless entry into and exit from the digital domain.

But we still need to retain what I hold to be the fundamental advantage offered by digital: a holistic view of techniques

chine represents a key building block in the transition to higher quality audio.

Within an on-air studio, a central VDU would enable cue lists of music, commercials and other sound files to be called up from permanent and removable hard-or optical-disk library storage, and then adjusted in level via a companion control surface.

Centralizing the access to large amounts of audio material and providing an easy-to-use way of extracting sound cues and their timing data greatly improves the creative freedom of on-air talent and production staff. (To say nothing of the enhanced flexibility available from a high-speed, truly random-access medium.)

And for the production-studio environment, non-destructive editing ensures continual access to the original source materials. Mistakes can be corrected instantly without searching for lengths of quarter-inch tape from previous edit sessions.

The same audio data can also be treated to a variety of digital EQ, compression and signal-processing algorithms to establish a different audio ambience than that suggested by the source material, or to add a "signature" reverb for station promos and other IDs. Once stored within the master CPU, all of these EQ, ambience and processing parameters would be instantly available to station personnel.

The use of standardized serial/parallel interface protocols will also extend the concept of connectivity to outboard digital recorders and ancillary systems, including existing station automation commanders.

I remain fully convinced that digital workstations, in one guise or another, are destined to streamline the record/replay, editing, signal processing and coordinating functions necessary in the air and production facilities of the '90s. I expect a rich harvest of new and enhanced technologies to be unveiled at the upcoming NAB Convention in Atlanta.

■ ■ ■

Mel Lambert has been intimately involved with the production and broadcast industries on both sides of the Atlantic for the past dozen years. Now principal of Media&Marketing, a consulting service for the professional audio industry, he can be reached at 818-753-9510.

GET IT RIGHT
GET IT FROM ALLIED

Make sure your favorite station* is registered to win

F R E E



2 Denon DN950FA CD Cart Players™
100 Denon ACD5 CD Carriers
1 Rack Mount (for 2 Denon machines)

To qualify, all entries must be *typewritten* on a radio or TV station letterhead* signed by the CE, or the GM or the PD and postmarked not later than April 23, 1990. The award will be made to the winning radio station by random drawing to be held on April 30, 1990.

Mail all entries to:

Allied/Denon Prize Drawing
Dept. RW
P.O. Box 1487
Richmond, IN 47375

ALLIED
BROADCAST EQUIPMENT
A HARRIS COMPANY
800-622-0022

3712 NATIONAL RD. WEST • P.O. BOX 1487 • RICHMOND, IN 47375
© 1990 HARRIS/ALLIED

Not for amateurs

You're no amateur at this game, so why play around with tried consumer models in the past, just to see if they'll work? You understand that. But in the long run, they *don't* make sense. And beefed up versions have given you headaches... wrong levels, hits or the wrong ones. Not to mention skips, mutes and breakdowns. Why take your chances with an amateur deck in a pro application? Leave that home player at home with the Studer A727 and A730—pro players for radio pros.

A727 \$1,995 ■ A730 \$2,995
REDUCTION! PRICE!
 Call Your Studer Revox Dealer Today.

A727 ▶ Thousands of A727's prove their reliability in radio stations all over the world—*everyday*. The A727 provides full 16-bit resolution with 4x's oversampling—plus powerful error correction circuits to protect against on-air problems from damaged or dirty discs.

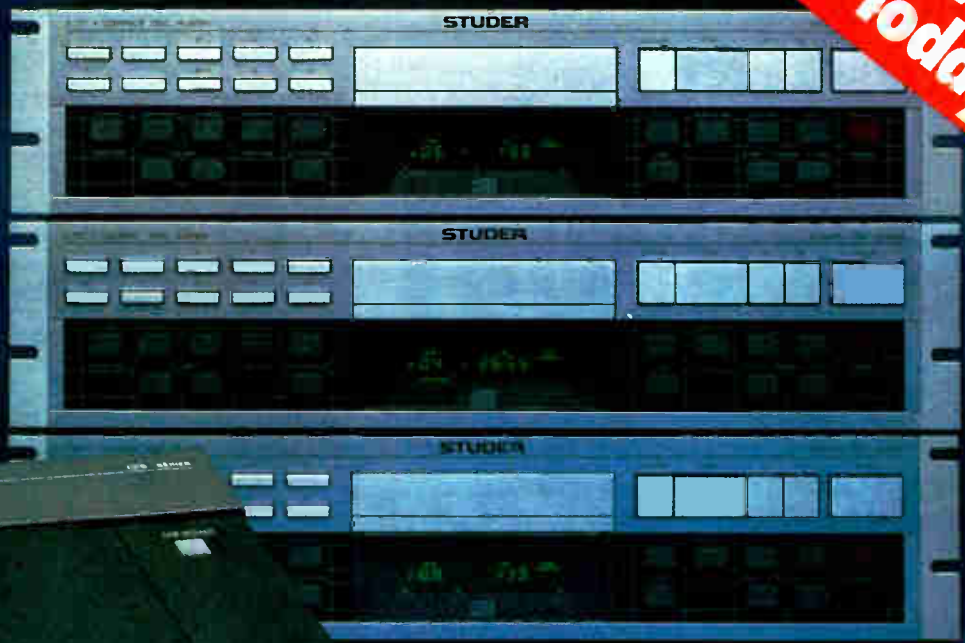

Designed for fast, creative production play, the **A730** is the newest addition to the Studer line of Pro CD players. This machine can recognize 100 discs and store up to 3 start cue points per disc. Its die-cast aluminum transport is built for professional use.

FEATURE	A727	A730	"Brand X" Player	FEATURE	A727	A730	"Brand X" Player
Fader Start	▼	▼		Disc Recognition		100 discs	
Parallel Remote w/Tallies	▼	▼		Varispeed Built-in		▼	
Start & End Review	▼	▼		End of Modulation Sense		▼	
End of Track Alarm	▼	▼		Monitor Speaker		▼	
RS422 Serial Control	▼	▼		Separate PGM & Monitor Outputs		▼	
System Clock in/out	▼	▼		Remote Monitor Speaker Mute		▼	
Digital Output	▼	▼		Audio Channel Reset		▼	
Die-cast CD Drive	▼	▼		Rack Mounts Standard	▼		
Cue Memories		3		Flush Mounting		▼	

Go ahead. Make the comparison.

Before those amateur machines break again, call your Studer Revox Full-Line Dealer, or contact us directly.

STUDER REVOX

Studer Revox America, Inc. • 1425 Elm Hill Pike • Nashville, TN 37210 • (615) 254-5651

Los Angeles, (818) 780-4234 • New York (212) 256-4462

In Canada, Toronto (416) 423-2831

Circle 99 On Reader Service Card

World Radio History

Souping Up Your Processor

(continued from page 31)

"attack time" and "release time." The attack time is how long it takes the processor to recognize a signal that is too high and turn down the gain. Release time is how long it takes the processor to bring the gain back up when the signal diminishes.

Riding again

These two time constants are not always set to the same value. For instance, the FCC is a lot more concerned about overmodulation than undermodulation. For that reason, processors used as peak limiters have very fast attack times and

slower release times.

Figure 1 is a simplified circuit for a gain riding processor. What's important are the components that set the time constants of the processing. This is almost always an RC, or resistor-capacitor network.

In this case the capacitor, C, stores the charge and determines how much feedback voltage is applied to the LED/Photocell electronic pot. Two resistors, R1 and R2, combined with capacitor C, set the time constants.

R1 sets the attack time. The RC time constant of R1 and C determines how fast the capacitor charges when the sig-

nal goes up. To speed up the attack time, replace R1 with a smaller resistor.

R2 sets the release time. The RC time constant of R2 and C determines how fast the capacitor discharges when the signal goes down. To increase the release time, make R2 larger. To decrease the release time, make R2 smaller.

Switching parts

Sometimes you want to speed up both attack and release and can simply replace C with a smaller cap. Substituting a 1 μ F tantalum for a 10 μ F tantalum will drastically change the sound of the processor. In fact, when substituting

parts, try changing the value by double or half until you get the feel for what is happening to the sound.

This particular schematic is simplified to highlight the RC action. In actual circuits, you'll probably find FET or VCA gain control elements. The action will also work on both positive and negative peaks. In other words, the circuit will be more complicated. However, the principles remain the same. Use the instruction manual or schematic to locate the time constant elements and make your changes to these and only these parts.

For multiband compressors, there is an attack and release time constant for each band. You'll find that the time constants are shorter for the higher bands than for the lower ones. Reduce these proportionately. Don't make them all the same.

Figure 2 is a chart of some typical time constant combinations and what you can expect to hear. Attack time is almost always kept shorter than release time in these processors. When the time constants get too short, distortion results. The distortion usually is evident in the low frequencies first. When the time constants are short enough to have an effect on individual cycles of a low frequency, then the shape of the waveform is changed, resulting in distortion.

When the time constants get too long, the effect of the processing is inaudible. Long time constants are used primarily for gain riding functions.

Fast attack and slow release time combinations have a tendency to "punch holes" in the signal.

The old audio saying of "it's right when it sounds right" certainly applies in this endeavor. Make your modifications a little at a time and give the changes a chance to prove themselves before moving on. It's too easy to get wrapped up in the excitement of hourly changes which are hard to analyze and which drive the staff to distraction.

■ ■ ■

John Shepler is an engineering manager, broadcast consultant, writer and regular RW columnist. He can be reached at 815-654-0145.

Berlin Wall

(continued from page 15)

the events that have followed, he said often in disbelief, are "amazing."

"Things are developing quickly," expressed Eckhardt. "But, in the moment you don't know what will happen in the next, say, four, eight or 12 weeks. Things are in motion."

World in motion

In full motion today are the letters—thousands of them—that SFB is receiving from East Germany. Listeners that were once cloaked behind the Iron Curtain are now becoming a part of West Berlin radio. And Western music that was once hands-off for East Berliners is now entering the Eastern block through the radio stations that they once listened to, but never dared talk about.

And sometimes, said Eckhardt, "for hours—or a day—we have the same programs." That, exclaimed Eckhardt, is also "amazing." It's an indication that while he might literally have been talking to a brick wall all these years, the listeners behind The Wall were, in fact, tuned in.

■ ■ ■

Dee McVicker is a free-lance writer and regular contributor to RW. To inquire about her writing service, call 602-899-8916.

3.5-5-10 kW

WATTS

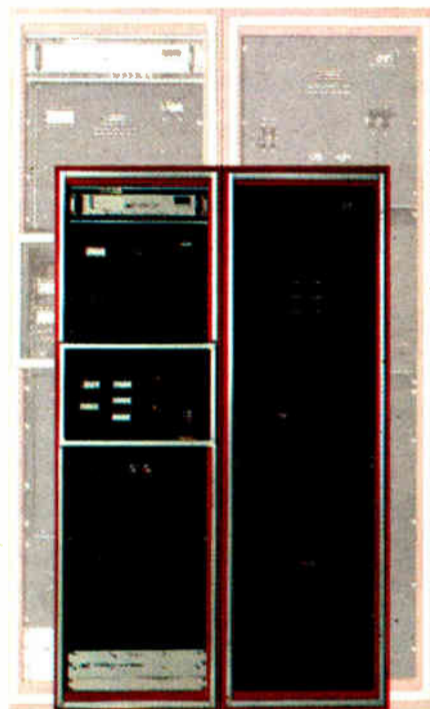

MORE

QEI

Quality • Engineering • Innovation

QEI Corporation • One Airport Drive
P.O. Box D • Williamstown, New Jersey 08094
Toll-free 800-334-9154 • Fax 609-629-1751
24 Hour Service Hotline 609-728-2020

20-30 kW

Circle 30 On Reader Service Card

World Radio History

Now here's a curious fact: Most FM transmitter manufacturers design "families" of similar transmitters with different power levels. The 3.5, 5 and 10 kW family, for instance, or the 20 and 30 kW. Yet only QEI has designed its transmitter families so you can economically upgrade power levels right in the field. Our new 20/30 kW FMQ 20000B/30000B, for example, drives its single tube final amplifier using interchangeable solid state IPA modules. This advanced design lets you upgrade from 20 kW to 30 kW overnight. And speaking of power, ours is the only 20/30 kW transmitter that you can order with the option of single phase power.

Here's another thing that's hard to fathom: Everyone's transmitter needs spare parts at some point in its life. Yet QEI is the only manufacturer to include every solid state component of the transmitter, exciter and remote

control in our spare parts kits—FREE.

Something else to ponder: Everyone buys tubes from the same sources, yet QEI is the only manufacturer to offer a 15,000 hour tube replacement warranty. And we've made the entire final amplifier just as trouble-free as our grounded grid triode tubes by eliminating conventional plate blockers and old-fashioned sliding contacts.

One final item to get you thinking: All top-rank manufacturers have a 24 hour major parts and service line. QEI's major parts depot, however, is just half an hour from a major airport—Philadelphia International. When minutes count, that could be important.

If other manufacturers can't solve these dilemmas, talk to the people who can. Call us at 800-334-9154, toll-free, for complete information on QEI's "New Reliables" field-upgradeable transmitters—the FMQ 3500/5000/10000 and the new FMQ 20000B/30000B.

“Auditronics’ 400 is the best production board for the money,”



Cameron Adkins
Chief Engineer
WYHY-FM
A Jacor
Communications
station



Bumper Morgan, Producer
WYHY-FM

says
Cameron Adkins,
Chief Engineer of Nashville's
outrageous Y107 FM. "In fact, Audi-
tronics' sound has helped make us number one
in our market for the last five books, and we expect to
capture our sixth one as well."

"After looking at all the production consoles that
were out there, we found the Auditronics 400 was the best
buy for the money. It had more useful features than any other
console in its class, and was less expensive overall. So we
decided to buy it not only for WYHY here in Nashville, but for
two of our other stations as well."

"We bought the light-bar metering version because
the ballistics and characteristics are more meaningful for what
the production engineer needs to know. Our producer,
Bumper Morgan, likes the light bars better than conventional
VU meters because he can see from across the room if he's
got one channel a little hot without having to stare at the
board all the time. The light bars also give the console a
high-tech look that helps our sales people when they

bring ad
agency and client
types in, because the 400 gives
us the best looking production room
in town."

Bumper Morgan, Producer at WYHY says,
"Auditronics has really set a new standard in radio production
consoles. Going from our old board to this 400 was like going
from night to day. The light-bar display gave me instant
gratification. I use the foldback modules a lot. I like the range
of the eq and the very clean overall sound of the board.
Besides our own work, I do a lot of promos, sweepers and
liners for other broadcasters from Honolulu to New York, and
I continually get compliments that the sound of our packages
helps stations sound better than their competitors."

Adkins says, "The Auditronics 400 was easy to
wire in. And nobody's board surpasses this 400 for reliabil-
ity or stability. We're a heavily produced station with seldom
a break that we don't air something that was produced here
on this board. Even with this heavy workload, we've had
zero failures. Literally nothing has gone wrong since
day one," he says.

Call 1-800-638-0977 toll-free today for more
information on the 400 production console Cameron
Adkins buys.



auditronics. inc.

Auditronics, Inc., 3750 Old Getwell Road, Memphis, Tennessee 38118 • 901 362 1350

Circle 6 On Reader Service Card

The Basics of Binary Counting

This is the third installment in a 12-part series called An Introduction to Digital Electronics. Northern Virginia Community College will offer 1.3 CEUs (continuing education units) to registered students who successfully complete the course and an examination mailed at its conclusion. To register, contact the Director of Continuing Education, Annandale Campus, 8333 Little River Turnpike, Annandale, VA, 22003,

or call 703-323-3159. The fee for the course is \$20.

The SBE will also allow this course to be counted toward certification.

Part III of XII

by Ed Montgomery

Annandale VA Usually the infor-

mation surrounding the manner in which digital information is encoded is not important to the technician in everyday use of digital equipment.

However, it is good to have an understanding of the various codes when involved with the design of equipment. The following should serve as a basic introduction to a variety of digital coding schemes.

trated in Figure 2.

The system functions well in electronics, but in order to make it work in a world dominated by the decimal system, a conversion must be made. The Binary Coded Decimal system is used to achieve this. Known as the BCD code, it represents the digits of 0 through 9 with a 4-bit code as illustrated in Figure 3.

This code can be used to express numbers greater than 9 by leaving a space between the 4-bit code. For example, 950 in BCD would be: 1001(space)0101(space)0000.

Figure 1. PLACE VALUE	1s	10s	100s	1000s	10,000s	100,000s	1,000,000s
POWER	10 ⁰	10 ¹	10 ²	10 ³	10 ⁴	10 ⁵	10 ⁶
	Units	Tens	Hundreds	Thousands	Ten-Thousands	Hundred-Thousands	Millions

Figure 2. PLACE VALUE	1 ²	2s	4s	8s	16s	32s	64s	128s
POWER	2 ⁰	2 ¹	2 ²	2 ³	2 ⁴	2 ⁵	2 ⁶	2 ⁷

Figure 4.

```

    graph LR
        A["input data  
"user friendly""] --> B[encoder]
        B --> C[processor]
        C --> D[decoder]
        D --> E["output data  
"user friendly""]
    
```

Figure 3. DECIMAL	BCD
0	0000
1	0001
2	0010
3	0011
4	0100
5	0101
6	0110
7	0111
8	1000
9	1001

Another code often used is the ASCII—the American Standard Code for Information. It is similar to BCD but uses a 7-bit rather than a 4-bit code. ASCII is used to transfer both digits and characters from one computer to another.

A third system that computers use

Our world contains a variety of number systems. The most commonly used is the decimal number system, consisting of the digits 0 through 9. As previously discovered, however, electronic circuits are capable of identifying only

... electronic circuits are capable of identifying only two conditions, not 10. Digital circuits are either high or low

two conditions, not 10. Digital circuits are either high or low. Thus, an alternative number system must be used.

Numbers and bases

The decimal system we use is known as Base 10. The place value of Base 10 is illustrated in Figure 1. Using the number 1475, it can be seen that the number is composed of:

- 1-Thousands;
- 4-Hundreds;
- 7-Tens; and
- 5-Units

Throughout most of your schooling, you have spent a majority of your time working in the Base 10 number system. But consider that there are other systems that we use daily. Time, for example, employs a Base 60 system, where 60 seconds or minutes will advance you to another place value.

Again remember, digital electronic circuits can only respond to two conditions: high or low. Thus, a much simpler system is used, consisting of two digits: 0 and 1. This system is known as binary or Base 2. In most American digital electronic circuits, a 0 is equal to a low level, and a 1 equals a high level. The binary place value is illus-

is hexadecimal. This is a Base 16 system employing numbers and letters. It is widely used in microprocessor systems and it allows for the reduction of the size of information being used.

Octal system

Older systems often employ an octal or Base 8 system. Such a system is similar to hexadecimal, but uses half as many numbers. A complete comparison of the number systems is illustrated in the ARRL handbook.

Regardless of what code is used, it is not seen when information is entered or withdrawn from a digital circuit. All inputs and outputs are made "user friendly." The equipment must use numbers, characters or linear signals a non-technical person can work with. It is encoded digitally, processed and then decoded back to easily identifiable non-digital data. This is illustrated in Figure 4.

Ed Montgomery currently is an electronics teacher at Thomas A. Edison High School in Fairfax County. He has taught broadcast engineering at Northern Virginia Community College and worked as a broadcast engineer for several radio stations.

CCA ELECTRONICS, INC.

25 Years of Reliable Broadcast Transmitters

For over 25 years, CCA Electronics, Inc. has provided reliability through simplicity. Specializing in simple circuitry and rugged construction, CCA manufactures dependable, longlife AM, FM, Shortwave and Longwave Transmitters.

CCA transmitters deliver durability and reliability to satisfied customers throughout the world. The high quality standards and design simplicity produces the best value of broadcast transmitters in the world.

FEATURES:

- Time Proven Long Life Design
- Rugged Construction with High Quality Components
- Zero bias Triode in DC Grounded Grid Circuit
- Conventional Plate Modulation
- Longest Documented Tube Life
- Designed for FCC, DOC and CCIR Requirements

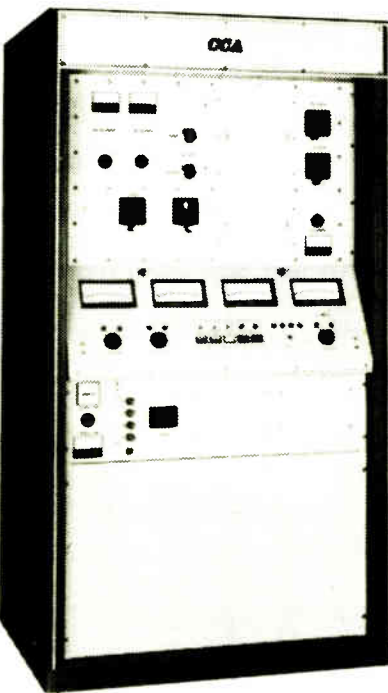

WE MAKE IT SIMPLE

CCA 360 Bohannon Road/P.O. Box 426, Fairburn, Georgia 30213
 Phone: (404) 964-3530 Fax: (404) 964-2222

College and Commercial Radio

(continued from page 28)

The stations were to be for the training of "students at both schools in the electrical engineering departments in radio transmissions," according to the Jensen paper. The original article concerning the new college station appeared in the Bryan Daily Eagle newspaper on 30 March, 1911.

The call for the special station was 5XB. The normal call at that time was 5YA—the "Y" denoted an educational station. It operated as a normal ham relay station for several years. Morse code was the means of transmitting information.

Relaying football

According to Jensen, the first Texas A&M-Texas football game was "broadcast" (either 1919 or 1921, depending on which source is believed) in code to several receiving sites in Texas. By using a pre-arranged set of abbreviations, the play-by-play comments could be relayed over lo-

cal public address systems where ham operators were set up to receive the game accounts.

Some of the stations set up to receive the broadcast were 5NI, Greenville; 5RS, Caldwell; 5JA/5ZAG and 5QY, Austin.

The call was changed to WTAW in 1922 on a vote of the student body, and reportedly stood for "Watch The Aggies Win."

There are one or two other "W" calls west of the Mississippi river, but I believe that WTAW is not the furthest west. It appears that WBAP (50K U, 820 kc), Fort Worth has the honor of being the station with a "W" prefix that is the westernmost in the US.

Rush of licensees

To paraphrase Erik Barnouw, author of "A Tower in Babel," there was a rush by educators to get into the new field of radio broadcasting in the early post-WWI years. In 1921, LDS University of Salt Lake City went on the air with KFOO.

According to Barnouw, there were 19 college stations on the air in the spring of 1922 and a total of 47 broadcasting by the end of the year. It was easy to get a license, as evidenced by the fact that a total of 74 college and university stations were licensed by the end of 1922.

Although the staying power of the educational stations was not great, the dropout rate among the commercial stations was even larger. Of the 702 or 703 commercial stations on the air at the end of 1922, only 576 were still on the air at the end of 1923—an attrition rate of 18%. The rate of demise among the college and university stations was only 10%, from a total of 72 to 65.

Other early entrants to the new electronic age were department stores, newspapers, laundries, garages, auto clubs, record stores, and AT&T.

The entry of AT&T was not originally planned to be to the RF spectrum, but rather was a concept of distributing programming by wire in the same manner that one used the telephone. The system was to be a form of "toll broadcasting," whereby one could push a button in the home and get the programming desired, according to Lloyd Espenschied in his "Recollections of the Radio Industry."

Anyone could walk in and purchase time and discuss whatever subject he or she desired. Some very interesting concepts that we see being used today are

cited. (For further reading, see *A History of Broadcasting in the United States*, vol. 1, by Erik Barnouw.)

The first radio toll station of AT&T was in New York City—WBAY, a 500 watt station located in the telco building at 24 Walker St. in lower Manhattan, with the antenna on top of the building. They had problems. The signal just did not radiate from this building.

This first location was replaced by facilities in the Western Electric building at 463 West St. The first station to go on from the new location was WEAJ, which replaced WBAY. Later calls for the station were WRCA and WNBC.

The "toll broadcasting" idea eventually took the form of program distribution to AT&T and Western Electric-equipped or licensed stations to the exclusion of the GE and RCA stations.

"Unlicensed stations" seems to be the term used to differentiate between stations who had purchased transmitters from either AT&T or Western Electric, or who had paid a license fee to AT&T for use of the patents that had been assigned to AT&T and Western Electric.

George Riggins has experience in radio and electronics dating back to the 1930s. He is also a licensed ham operator and has had his own broadcast sales and service company, Riggins Electronic Sales, for over 20 years. He can be reached at 213-598-7007.

It Pays to Review Logs

(continued from page 22)

ure of *any* light. Note that the indicator (often a remote control) must indicate the failure of *any* light; however, 1748(b) does not require the reporting of outages of steady burning intermediate lights to the FAA.

Finally, 1749 requires the logging of any observed extinguishing of a tower light (whether a flashing beacon or a steady burning lamp). This section does not require the logging of the inspection, unless the inspection reveals that a lamp is out. Several stations were cited for not logging the daily or quarterly tower light inspections, although no rule requires these inspections to be logged.

For the Chief Operator to be able to ensure that the station is operating within the terms of license and the rules, it would help to enter more data in the station log than is specifically required. In this case, it would be helpful to have operators log the time that the tower light inspection was accomplished and the results of the inspection. In the weekly log review, make sure that these entries are being made.

The posted operator instructions should tell how to determine whether it is a flashing beacon or a steady burning side light that is out. Failure of either is to be logged. Failure of a beacon requires the FAA be notified within 30 minutes. In a few cases, stations have said they notified the FAA, but the FAA had no record of the notification.

Take names

Have the operator get the name of the FAA person notified. As part of your weekly log review, check with the FAA to make sure the notification is still on record. Finally, lights are to be repaired "as soon as practicable" (17.56(a)). One station was told in a Notice of Apparent Liability that the repair should be completed within 15 days.

Summarizing, have operators log the daily inspection, check for the inspections during your weekly log review and make sure the operators can detect the failure of *any* lamp.

Ensure that the *current* station license

(including renewal cards, etc.) is posted at the principal control point. Photocopies should be posted at other control points (such as the transmitter itself).

Insure that *all* operator licenses are posted at the control point where the operator is on duty. Having a Restricted Permit card in the wallet is not sufficient. That card (or other license certificate) must be posted at the control point where the operator is on duty for as long as the operator is employed by the station. Where the operator is employed by other stations, a photocopy may be posted at each other station.

As part of your log review, you may wish to check that all operators who signed the log have licenses posted. The FCC will! By the way, you *do* have a written designation of chief operator posted, right?

Harold Hallikainen is president of Hallikainen & Friends, a broadcast equipment design, manufacture, sales and installation firm. He can be reached at 805-541-0200.

Oh-Oh!

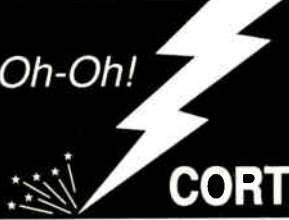

Call
CORTANA

STATI-
GAT

The
Affordable
Lightning
Prevention
System

- Charge dissipation with 1/8", type 304, sharpened stainless steel rods
- Won't bend from ice/severe weather
- Provide a continuous low-resistance discharge path for static electricity



Write for a Free Brochure.

P.O. Box 2548, Farmington, N. M. 87499
Call (505) 325-5336

ATTENTION SOUTHWEST BROADCASTERS

Northeast Broadcast Lab, Inc. is pleased to announce the opening of its new Southwest Sales Office.

Based in Plano, TX, the office will be headed by Doc Masoomian, who brings over 45 years of professional broadcast engineering experience to the Northeast Broadcast Lab organization.

For prompt, regional attention to your broadcast needs, contact:



NORTHEAST BROADCAST LAB, INC.

Serving the Broadcast Industry Since 1961

MAIN OFFICE	MID-ATLANTIC	NEW ENGLAND	SOUTHWEST
P.O. Box 1179 S. GLENS FALLS, NY 12803 Tel: 518-793-2181 FAX: 518-793-7423	P.O. Box 565 SOUTHAMPTON, PA 18966 Tel: 215-322-2227 FAX: 215-953-0523	P.O. Box 406 AUBURN, NH 03032 Tel: 603-483-1002 FAX: 603-483-2352	P.O. Box 867717 PLANO, TX 75086 Tel: 214-612-2053 FAX: 214-612-2145

Broadcast Equipment Exchange®

"Broadcast Equipment Exchange" accepts no responsibility for the condition of the equipment listed or for the specifics of transactions made between buyers and sellers.

AMPLIFIERS

Want to Sell

Ramko DA mono in 3.5" cabinet, working cond., BO. P Hess, 134 Derwent, Pgh PA 15237. 412-366-1249.

Marantz 1 PM 200 stereo amp & pre amp, like new, \$150; Altec 1607A power amp & 5 chnl mixer w/meter, 200 W mono, \$200. J Parsons Sr, Parsons Electr, 10375 Cannas, N Huntingdon PA 15642. 412-863-9590.

Crown PSA-2 500 W stereo pwr amp, excel cond., \$750 pls shpg. W Laughlin, 753 Ruth, Hurst TX 76053. 817-282-9033.

Shure Vocalmaster 6 chnl 100 W, 4 out of 6 chnl mixer work gd, \$150/BO. K Taylor, Image Support, 103 N Aspen, Sterling VA 22170. 301-864-4841.

Peavey PA-400 six input amp w/individual input EQ, \$245. J Sigmon, WBZK, POB 398, York SC 29745. 803-684-4241.

Lauderdale Labs LEL DA-8 (6), new, 8 chnl mono, 4 chnl stereo, \$150. G Walden, KYW, 5th & Market, Phila PA 19106. 215-238-4893.

Sony TA-3060 60 W stereo basic, compact, excell cosmetics, one chnl slightly weak, \$40; Crown IC-150 stereo preamp, rack mounting option, mint cond, orig box & packing, \$135. B Laughlin, 753 Ruth Ln, Hurst TX 76053. 817-282-9033.

Crown 75 power amp, very clean, SAE 31 in black, \$200 ea. Mr. Keith, ALI, Box 313, Keene NH 03431.

Straight Wire Audio PH-2B-U audio phono preamp, \$150. T Teagarden, KELI, POB 3834, San Angelo TX 76902. 915-655-9879.

Russco 4428 dist amp new cond., (4) separate 1x4 amps w/adjustable outputs in one unit, rack mount incl, \$300.

Olson AM 220 pre-amps (3), Realistic stereo, G/E mono, \$10 ea pls UPS. G Kirby, Marysville Bacs, 13613 US 36, Marysville OH 43040. 614-261-8871.

Crown D-60 exc cond., \$350. R Glenn, 1718 Shenandoah Road, Wimauma FL 33598. 813-634-1940.

Crown Micro-tech 600 LX stereo pwr amp, \$550; McIntosh 250 solid state pwr amp, \$350. D Lundy, POB 408, Heidrick KY 40949. 606-546-6650.

Realistic STA2100-D exc cond., 120W per chnl, \$150. R Glenn, 1718 Shenandoah Road, Wimauma FL 33598. 813-634-1940.

McIntosh MA-5100, stereo 50/50 wat integrated amp in good condition. W Dudley, 6919 19th Street, Tampa FL 33610. 813-237-6516.

Sony TA-2000F classic metered preamp, excel cond, \$80. W Laughlin, 753 Ruth Ln, Hurst TX 76053. 817-282-9033.

McIntosh MC-2500 unused, \$3000; MC-240, \$1200; MC-60 (2), MC-40, MC-225 (2), \$600/ea. R Katz, 15015 Ventura Blvd, Sherman Oaks CA 91403. 818-377-5264.

Dynaco ST120 60 W/ch amp, \$35 plus shpg. M Holwin, Anamnesia Studios, 40 South Oxford Street, Brooklyn NY 11217. 718-852-7630.

Want to Buy

Marantz 7 preamp. J Parsons Sr, Parsons Electr, 10375 Cannas, N Huntingdon PA 15642. 412-863-9590.

Tube amps & remote mixers, RCA Op-6, Op-6, BN-2, BA series, 60 series, etc. B Davies, Virgo Prod, 5548 Elmer, N Hollywood CA 91601. 818-761-9831.

EICO HF-89A 50 W dual stereo amp, 30 yr old tube type, any cond, will pay shipping. K Smith, Smith Engr, 118 Barstow, Gorham ME 04038. 207-892-6776.

ANTENNAS & TOWERS

Want to Sell

RCA 3 bay Class A, 106.3 antenna. T Rusk, KWTD, 704 Roberts, Lonoke AR 72086. 501-375-1440.

Allied 42UCS/SR 65' self-supporting tower, 8 yrs old, excel cond, on ground, solid rod, \$5000/BO. O Thein, Kirkwood Community College, 6301 Kirkwood Blvd SW, Cedar Rapids IA 52406. 319-398-5663.

---FOR SALE---

Blaw-Knox 440' SS tower, \$125,000 installed; Harris 101.7 super high pwr FM antenna, like new & 500' 3-1/8" rigid RCA line, antenna & line \$18,000 installed; 2000' assorted 7/8" transmission line & 1000' 1-1/2" transmission line; assorted UHF/VHF 2-way antennas, \$150 ea.

Nationwide Tower Inc.
904-932-3004

Rohn 65G 397' tower, 3 yrs old, guy wires, beacon, side lights, will sell standing, \$6000 or on ground, \$16000. M Blakemore, WCVP, Box 280, Murphy NC 28906. 704-837-2218.

Scientific Atlanta 8005 earth station satellite antenna, 4.6 meter, disassembled, you pay shipping & labor to load, free. O Thein, Kirkwood Community College, 6301 Kirkwood Blvd SW, Cedar Rapids IA 52406. 319-398-5663.

CAPACITORS OVERNIGHT

• Power Supply computer grade: up to 450VDC

• Transmitting - MICA Sangamo, Cornell-Dubilier

• Oil Filled Non-PCB Oval, Rectangular

Relays • Filters • Transistors
Any Parts starting with 1N or 2N

1-800-323-0460

FAX 1-802-425-3664
Kellner Electronics, Inc.
Charlotte, VT 05445

Hughey & Phillips T12035 35 KVA tower isolation transformer, 115/230 VAC input 117-120 VAC output 3500 W w/instructions, \$1150. N Winter, KLAY, 10025 Lakewood, Tacoma WA 98499. 206-473-3462.

Andrew 1-5/8" gas pass Helix flanges, (4) unused, \$75 ea/BO. D Carver, KZBK, 107 S Main, Brookfield MO 64628. 816-258-7458.

ERI G5CPS 3-1/8" circularly polarized 10 bay w/decibers tuned to 106.5. R Sweatte, KXXR, 600 Broadway Ste 220, Kansas City MO 64105. 816-421-1065.

Dielectric DCRC antenna bays w/rodomes. M Young, WJON, POB 220, St Cloud MN 56302. 612-251-4422.

Rigid line, 380', 3", vgc, very little use, some spring type hangers included, \$4275/all or \$225 for ea 20' section. J Sigmon, WBZK, POB 398, York SC 29745. 803-684-4241.

Kintronic CVCJ1000-5S isolation coil in weatherproof housing w/tuning capacitor. D Engstrom, KOIA, 820 W Second, Ottumwa IA 52501. 515-684-5415.

Andrews 120' + of 3-1/4" helix on spool w/connectors, excel cond, less than 1 yr old, \$875. J Sigmon, WBZK, POB 398, York SC 29745. 603-684-4241.

Scala HDCA-10EB yagi antennas, 75 ohm, 104.1 & 106.9 MHz. D Leinen, Independent Resources, POB 23498, Oklahoma City OK 73123. 405-721-1187.

RCA 3 bay class A 106.3 MHz antenna, BO; ERI 8-bay class C FM 98.5 MHz; also various 3-1/8" Andrew hardline connectors, BO. T Rusk, KWTD, 307 Roberts, Lonoke AR 72086. 501-375-1318.

Guyed tower, 713', 48" face w/reduced top section, less than 4 yrs old w/medium intensity strobe system, BO. F Giardina, Dittman Group, 2146 Highland, Birmingham AL 35205. 205-933-9274.

Berkhalter 300' tower, 18" face, 4 yrs old, w/1-5/8" transmission line & 3 bay antenna mounts, \$7000. T Cooper, WGRQ, POB 689, King George VA 22485. 703-775-3744.

Rohn 80 tower, 495' including 50' pylon, excel cond, on ground, FOB Gambrells MD, \$15,000. B Sadlier, WFSI, 918 Chesapeake, Annapolis MD 21403. 301-269-6500.

RCA BFA 8 bay FM, hor polarization on ground, complete, BO; Continental 300C 8 bay FM, vertical polar on ground, complete, BO; 400' 3-1/8" rigid coax in 20' sections on ground, BO. J Gray, WPF8, 4505 Central, Middletown OH 45044. 606-781-5715.

RCA BFC-7 high pwr 7 bay, tuned to 95.5 MHz, gd cond, circularly polarized, BO. J Boxler, WKYE, 109 Plaza Dr, Johnston PA 15905. 814-255-4186.

Andrews 6-1/8" rigid line, 1000' 51-1/2 ohms, over 20 yr old, BO; Andrews 400' 1/2" helix, BO; (6) rolls 1" copper, one roll 3", one roll #10 or #12 bare wire, BO. R Myers, KMBR, 4935 Belinder, Kansas KS 66205. 913-677-8944.

FM ANTENNAS

1 BAY	\$1,500
2 BAY	2,300
3 BAY	3,150
4 BAY	4,000

MORE BAYS AVAILABLE
All warranted, tuned
and tested

ARMSTRONG TRANSMITTER CORP.
5046 Smoral Road (315) 488-1269
Syracuse, NY FAX (315) 488-1365

Phelps Dodge 12 bay tower mount FM antenna, 97.5 MHz, gd cond, BO. E Monskie, Halls Comms, 24 S Queen, Lancaster PA 17603. 717-397-0333.

Jennings Model RC21 vacuum coaxial relay, new, \$1600. A Emerald, KGGG, 8956 Swallow, Fountain Valley CA 92708. 714-962-5940.

Advance model 155, heavy duty towers, 370' & 160', will hold 12 or more bays FM antenna, dishes, etc, can combine for 530' tower, excel cond. R Wright, WLLX, 1208 N Locust, Lawrenceburg TN 38464. 615-762-2916.

Dummy Loads RF Plumbing RF Cable FM Antennas

ARMSTRONG TRANSMITTER CORP.
5046 Smoral Road (315) 488-1269
Syracuse, NY FAX (315) 488-1365

Andrew 2260B 7/8 EIA to N coax adapters, \$100. H Larson, Matrix TV, POB 536, San Luis Obispo CA 93406. 805-544-5657.

Shively 6810 10 bay, 2.5 yrs old, tuned to 101.1 MHz, \$11,000. A Baxa, WAVV, 11800 Tamiami Tr E, Naples FL 33962. 813-775-9268.

Dielectric 4 1/16" rigid transmission line, 50 OHMS, 25-20 sections, Call C Williams 904-763-1035.

Miter elbows, 90 degree, 3-1/8" (8), EIA flanges. M Cramer, WBGA-TV, 1391 North Rd, Green Bay WI 54307. 414-494-2626.

Shively 6813 NP's FM 3-bay antenna w/coax mounts couplings, like new, \$3547/BO. L Torgersen, WQIC, Box 5353, Meridian MS 39302. 601-693-4851.

Advance 155 370' (2) steel towers w/lights, will support 12 bay FM antenna. R Wright, WLLX, 1208 N Locust, Lawrenceburg TN 38464. 615-762-6200.

Windcharger 300 ft, 18 in face well maintained, standing, Continental 8 bay circular polarized antenna at 107.1, 300 ft Andrews 1 5/8" line, \$20000. J McBride, Box 464, Osceola IA 50213. 515-342-6538.

RCA 3 bay class A antenna, 106.3 MHz, BO. T Rusk, 501-569-8485.

ERI 8 bay class C FM, 98.5 MHz & various 3 1/8" handline connectors, BO. T Rusk, 501-569-8485.

RCA MI-19089-2C 3-1/8" flanged, never used (8), BO. B Maxwell, 6053 Bunker Hill, Pittsburgh PA 15206. 412-661-2020.

Austin ring lighting transformer, 30 yrs old, \$400/BO. D Jack, Mtn. Media. 208-286-7676.

Gates 6 Bay cycloid tuned to 106.5, call for info. J Dunsan, 304-623-6546.

PiRod s.s. 100' tower. Windload 40 sq ft. Includes template, brackets, anchor bolts. On ground. John at 608-845-6755.

ERI FMHH G5-4 4-bay, high power horizontal only 4 bay antenna tuned to 94.5 MHz +/- 3 MHz. Available in Eugene, OR. Contact Chris Reid Murray, CE, KMG. 503-484-9400.

Want to Buy

Tower, 418' FM, 600' cable 1-5/8", 2 bay antenna tuned to 96.3, also beacon. LJ Maierhofer, WTGC, 101 Armory, Lewisburg PA 17837. 717-523-3271.

CP antenna, 6-8 bay, tunable to 96.9 MHz, minimum 10 kW input rating; 500' 700' tower, must be cheap. D Carver, KZBK, 107 S Main, Brookfield MO 64628. 816-258-7458.

WANT TO BUY -FM ANTENNAES- (Circular Only) Any Condition

ARMSTRONG
TRANSMITTER CORP.
5046 Smoral Rd
Syracuse, NY
(315) 488-1269
FAX (315) 488-1365

Need 190' AM used guyed tower. G Vaile, KITA, 723 W 14th, Little Rock AR 72202. 501-375-1440.

Self supporting tower, 75' in gd cond, light to medium load capacity. E Goetsch, WXPB, 303 W Prospect, Rhinelander WI 54501. 715-362-6000.

Tower, 900-1100', on ground or standing needed by 2/1/90. K Austin, KFXI, POB 392, Marlow OK 73055. 405-658-9292.

AM phasor cabinet, 5 tower 1kw tower, w/tuning components, any freq, gd cond., T McGinley, WPGC, Box 10239, Washington DC 20018. 301-441-3500.

Coaxial patch panel 3-port, 3 1/8 inch w/U-link, reasonable, cost effective, economical. K Brown, Box 808, Riverton WY 82501. 307-856-2922.

FM antenna 3 bay horizontal. E Jenner, 102 Elm, Washington MO 63090. 314-239-6800.

Heavy 500' guyed, galvanized tower. M Vaande Vort, Rte 3 Box 214, Pella IA 50219. 515-628-1724.

AUDIO PRODUCTION

Want to Sell

SAE 180 4 chnl parametric EQ, excel cond, \$200. W Laughlin, 753 Ruth, Hurst TX 76053. 817-282-9033.

Audiolab TD-2 degasser, will handle 2" tape, w/lmer & fan, \$150 pls UPS; Altec 1591A compressor, mint, \$175. J Kreines, DeMott/Kreines Films, 5330 Kennedy, Millbrook LA 36054. 205-285-6179.

Revox B-77 remote tape drive control, full function w/25' cord, never used, \$50; Shure Level Lok audio level controller for mics, new, \$100; UREI 527-A 27 band 1/3 octave EQ w/security cover, \$450. B Spitzer, KKLS, Box 460, Rapid City SD 57701. 605-343-6161.

Various pieces of studio equip including Sound Craftsmen TG-2209-600 EQ; Ampex tube type mic mixer; Ampex 351 tube type R-R; Ampex tape transport system; mc swivel stands; BE cart rewriter; Tapeaster 700-RP stereo cart machine; Marti omni-directional antenna; Rust remote control system, call for details on all these items. Adolph, 915-949-2112.

Beyer DT 109 headsets (2), vgc, \$100 ea. M Rice, WKBO, 2360 Hampton, St Louis MO 63139. 314-644-1380.

Luxo-LM 1 mic arm, beige, almost new w/table mount, \$30/BO. W Dougherty Jr, 314-998-2377 aft 6PM.

Henry Engineering Mix Minus Plus, never used, \$160. T Driggers, 818 Quail Ct, Healdsburg CA 95448. 707-433-9370.

SM-7 (2) in excel cond; MAP two processor mdl 231; Ampex ATR-700 in excel cond; Ampex 8 chnl board in gd cond, you pay freight. Pam Sutherland, WFGN, POB 1388, Gaffney SC 29340. 803-487-7885 aft 5PM.

Ron Radio Communications, Inc.

P.O. Box 201
Brightwaters, NY 11718

"Always the Best for Less..."
Micro Controls, Inc. Composite STL

RON RADIO PRICED AT \$5,695

1-800-666-3525
FAX: 1-516-665-6482

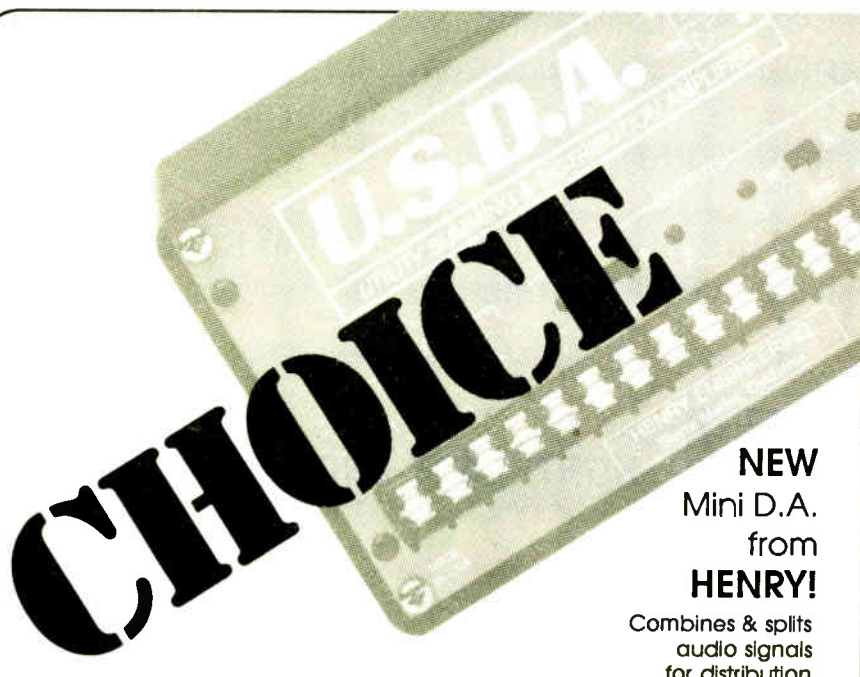

CHOICE

NEW
Mini D.A.
from
HENRY!
Combines & splits
audio signals
for distribution

For the FULL picture...

Call toll free...



5618 Odana Road Madison, WI 53719-1208

Audio & Video
Equipment & Supplies
(800) 356-5844
Consultation
(608) 271-1100

AUDIO PRODUCTION . . . WTS

Tascam 42B used 6 mos, \$250 pls \$25 shpg. D Peluso, KJUL, 2880 E Flamingo Ste E, Las Vegas NV 89121. 702-732-2200.

Mic-Mix XL-210 reverb unit, new, BO. G Chapekis, POB 22122, Denver CO 80222. 303-721-9156.

Orban 111B reverb unit, like new, BO. S Chapekis, POB 22122, Denver CO 80222. 303-721-9156.

dbx 140A type II NR units (2), \$250 ea or \$425/both plus \$20 shpg. D Peluso, KJUL, 2880 E Flamingo, Ste E, Las Vegas NV 89121. 702-732-2200.

Shure M267 & M268 M267 \$350. and (2) M268 \$190/ea. mint cond. Orig. manuals and pkgng. D Jackson, 708 E. Whaley, Longview TX, 75601, 214-236-3015.

Tascam 10 12 x 4 prod board (2), sold as a lot only, \$300 u-pick up/\$500 we ship. L Albert, WKMS, POB 2266, Murray KY 42071. 502-762-4664.

Symetrix T-101 Telephone interface never used (2), BO. D Eresy. 509-945-4855 am.

Shure M267 mixer, like new, BO. D Eresy. 509-945-4855 am.

Orban 245F Stereo synthesizer, never used (2), BO. D Eresy. 509-945-4855 am.

Orban 8000 6 yrs. old, gd. cond. \$1800. B Weeks, P.O. Box 107, B Falls VT 05101. 802-722-4890.

Shure SE-30 mixer/compressor, rack mtg, \$135; Soundcraftsman RP-10-12 10 band graphic EQ, pro VU-metered, 600 ohm out, rack mountable, \$125; Altec 1650 1/3 octave graphic EQ, mono, w/security cover, rack mtg, \$135. W Laughlin, 753 Ruth Ln, Hurst TX 76053. 817-282-9033.

Audio production company quitting business everything goes, write or call for complete list of inventory. Fred Arthur Productions, 1218 E 18th Avenue, Denver CO 80218. 303-832-2664.

Telcom C4 DM cards (2), new, \$495/ea. C Richardson, 1938 Baltimore Annapolis Blvd, Annapolis MD 21401. 301-757-3733.

Studio Sound S-305 passive filter sets (2), matched pair, rack mount, very rare, \$250 ea/BO. R Katz, 15015 Ventura Blvd, Sherman Oaks CA 91403. 818-377-5264.

Dolby feature films portable NR frame in stereo accepts Dolby, dbx & Telcom cards, works on AC or DC & is designed for Nagra IV-S, but works w/other machines, \$1295. C Richardson, 1938 Baltimore Annapolis Blvd, Annapolis MD 21401. 301-757-3733.

Want to Buy

Texas FM (2), in gd cond. K Hedge, Box 351 Pulaski VA 24301. 703-980-2702.

WANTED
PULTEC EQ'S

We will pay \$1000.00 for almost any Pultec program EQ models EQP1/EQP1A/EQP1A3.

We will pay \$1500.00 for any Fairchild 660 and \$3000.00 for any Fairchild 670.

Also wanted:
EQH2/EQH3/MEQ5/MAVEC/
MB1/ITI & SONTEC EQ any S/
tube or ribbon mics and limiting
amps.

CALL OR WRITE TO:
Dan Alexander Audio
2944 San Pablo Ave.
Berkley, CA 94702
(415) 644-2363
FAX: 415-644-1848

New start up class A FM station seeking transmitter, consoles, cart machines, monitors & microphones. S Norris, 313-234-4335.

Digital delay for telephone or other audio source. P Olliver, 89 FM, Stephenson Street, Blenheim, New Zealand. 064 57 88520. FAX 064 57 80389.

Shure M-63 Audiomaster w/rack mount, (2). Motor Sports Radio, 1285 Zevan, Johnson City NY 13790. 800-462-5677.

AUTOMATION EQUIP

Want to Sell

Revox PR-99 4 deck, original boxes; P-3A controller, BO. J Phillips, WZOM, 409-1/2 Clinton, Defiance OH 43512. 419-784-1059.

Sono-Mag/IGM mono 24-slot Carousel cart players (2) in roll-around rack, spare parts & manuals, vgc, \$650 ea. shpg. B Mounjo, WIDD, POB 1240, Elizabethton TN 37644. 615-543-5849.

BE Control 16 including (4) Scully R-R (PB only), new heads in box, (2) 42-cart IGM Go-Carts, 24-cart IGM Go-Cart, new, (2) BE cart decks (PB only), BE triple cart deck (PB only), new pwr supply, new upgraded source cards, now in use, \$25,000. D Switzer, KAML, POB 1009, Gillette WY 82717. 307-682-4747.

Used, Demo, Returns,
Tradein's, Overstock,
Scratch and Dent—
Limited Quantity,
First Come,
First Served
Terms:
Payment with Order

AKG D1200E MIC	\$125
AKG D190ES MIC	85
ATI P1000-1 PREAMP	295
ATI DA2016 DIST AMP	975
BARCUS BARRY 202a	
PROCESSOR	295
BENCHMARK DA 101 DIST AMP	250
BENCHMARK mda101 DIST AMP	275
CRL SGC-800 STEREO LIMITER	1400
EV SENTRY100A SPEAKERS	195
EV PL10 MIC	150
EV PL20 MIC	354
EV RE15 MIC	225
EXCALIBUR CD-1 AUDIO	
INTERFACE	77
JBL 4312 SPEAKER	225
JBL 4401 SPEAKER	115
LUXO COPY STAND	55
MARANITZ HE82 SPEAKER	40
MCMARTIN AMR-1 AM RCVR	95
MICROTRAK 10P	95
MICROTRAK TELEFLE	125
MOD SCI CP-803 COMP PROC	1025
MOD SCI SCA 186 SCA GEN	2800
MOD SCI MODMINDER	2155
MOSELEY ICU-3A ISOCOUPLER	275
OMNIMOUNT 101-SWA	37
ORBAN 424A COMPRESSOR/LIMITER	825
ORBAN COMP. ISO. XFMR	165
ORBAN XT2 6 BAND	
PROCESSOR	1725
OTARI MTR 12-1 1/2" 4 CH RECORDER	8900
OTARI MX5050 MKIII-2 (minor damage)	3295
OTARI CTM 10 CARTRIDGE PLAYER	1850
OTARI CB109	
REMOTE CONTROL	1225
OTARI ARS1000DC TAPE PLAYER	900
RADIO SYSTEMS DA-8 AMP	275
REVOX B77 TAPE RECORDER	1895
REVOX PR99 R/R ROLL	
AROUND STAND	350
RUSSCO STUDIO PRO TT	325
SANSUI CDX701 CD	410
SANSUI CDX711 CD	695
SHURE SM7 MIC	350
SHURE 330 DEMO MIC	140
SONY PCM2500 DAT RECORDER	2300
SONY CD5 PROII CASSETTE RECORDER	650
SONY TCD-D10PRO PORTABLE DAT RECORDER	2200
SONY C48 MIC	700
STRAIGHT WIRE AUDIO DA CARDS 195.00 PWR SUPPLY	40
TAPCO 4400A REVERB RECORDER	125
TASCAM 112R CASSETTE RECORDER	595
TECHNICS SP 15 TT	490
TECHNICS SP10MKII TT	795
TECHNICS SLP 550 CD	195
TECHNICS SLP1200 CD	935
TECHNICS SLP 1300 CD	1225
TECHNICS SLP 222 CD	225
TECHNICS SLP 3 CD	100
TECHNICS SAF2MK2 SPEAKERS	220
TECHNICS SLP770 CD PLAYER	350
TECHNICS SL1200MK2 TT	340
TELEX WIRELESS MIC FMR-2	925
TELEX PH75 HEADSET	85
UREI SR1 RACK MOUNT	20

NORTHEAST BROADCAST LAB
(518)-793-2181/(215)-322-2227
(603)-483-1002/(214)-612-2053

SMC DPI-C automation system including (4) 350 RSB Carousels, (4) SMC/Otari R-R PB, SMC dual cart, single play deck, (4) matching equip racks, logging w/X-tel printer, digital programmer w/brain & remote encoder w/monitor & manuals, \$13,500. Deb, KCIM, POB 886, Carroll IA 51401. 712-792-4321.

Schafer 800-S solid state 10 chnl system, \$800; Schafer 902 solid state system w/new cards, 10 chnl, 4 racks, net join, remote control, 6-24 tray Carousels (250's), 5 random access units, \$5,875; 2 racks, \$100/ea. T Noordyk, WSHN, 517 N Beebe, Fremont MI 49412. 616-924-4700.

IGM 48 tray Go-Cart, mono (2), may need some repair, \$700 ea. T Devine, WVLC, Box 1559, Lexington KY 40592. 606-253-5900.

Complete budget automation system, (2) Ampex VIF 450, 1/2 trk mono PB decks, controller w/ether 25 Hz or silence sense, excel cond w/spare parts & manuals & 8' rack, \$1000 pls shpg. B Mounjo, WIDD, POB 1240, Elizabethton TN 37644. 615-543-5849.

Schafer 800 w/schematics, (4) Ampex reels, needs work, \$1000/BO. D Niccum, KOZA, 1301 S Crane, Odessa TX 79760. 915-333-3101.

SMC DPI-C, automation system, complete w/(4) 450 RSB Carousels, (4) SMC/Otari R-R PB decks, SMC dual cart, single play deck, (4) matching equip racks, logging w/X-tel printer, digital programmer w/brain & remote encoder w/monitor & manuals, \$13,500. Debra Kulbel, KCIM, POB 886, Carroll IA 51401. 712-792-4321.

Otari ARS1000 automation R-R PB deck, w/25hz sensor; excel cond, \$1200 or BO. M Brown, 503-245-4889.

Harris 9003, including (5) PR 99, (3) instacarts, (2) terminals, printer, Wegener set rcr, (3) Harris racks, options are optional, BO. N Schwantz, WXYT, 15600 W 12 Mile, Southfield MI 48076. 313-569-8000.

Schafer 903 controller & keyboard w/printer, cables, \$3500. G Gaskey, Box 158, Weed CA 96094. 916-938-3828.

IGM 12-tray Instacart, \$1200. G Gaskey, Box 158, Weed CA 96094. 916-938-3828.

Schafer 8000 automation computer system, CRT terminal, printers, encoded logging, 4 racks, 4 new Tascam 32 RR decks, 2 SMC Carousels, w/ 1 complete extra brain, \$6000. G Gaskey, Box 158, Weed CA 96094. 916-938-3828.

Schafer 903 w/3 RR PB decks, 3 random access Carousels, 2 printers, 3 racks, encoded logging, listload, every option, extra RR source cards, extra parts, \$6800/BO. G Gaskey, Box 158, Weed CA 96094. 916-938-3828.

IGM RAM/NTI automation system w/48 tray mono Instacart, Wegener sat w/SMN circuit cards, \$11,000, in use, exc cond. J McBride, Box 464, Osceola IA 50213. 515-342-6536.

SMC equipment racks (5) \$1000/all; SMC time announce, \$450; DP-2 Brain w/remote start, \$1800; DC-8 Super Clock, \$225. G Elder, PO Box 869, Covington GA 30209. 404-786-1430.

Autogram C-2 dbl Carousel control, diodes on a punch board in drawer, for two RAS Carousels, \$175; Hallikainen TAX-161 time announce cont, \$100. D Jack, Min. Media. 208-286-7676.

SMC mono dual play cart deck, vgc, \$400. D Jack, Min. Media. 2080286-7676.

SMC 350 Carousels (3) \$2800/all. G Elder, PO Box 869, Covington GA 30209. 404-786-1430.

Otari ARS-1000 RR playback w/25 Hz sensor, \$950. G Gaskey, Box 158, Weed CA 96094. 916-938-3828.

SMC 250 RSC Carousels (3) \$11800/all; RSC-50 random select SMC programmer, \$200; RSC-100 programmer, \$275; 510 SMC single cart PB, \$150; SLS-2 Silence Sensor, \$125; DC-7 Clock, \$225. G Elder, PO Box 869, Covington GA 30209. 404-786-1430.

Want to Buy

Entire set-up for Transtar ACII & cart carousel. W Axell, KSAY, POB 2269, Ft Bragg CA 95437. 707-964-5729.

SMC TS-25 tone sensor. P Gray, KJJD, Box 399, John Day OR 97845. 503-575-1185.

IGM 500 System wanted, any cond, BO. T Murray, 100 W 9th Suite 306, Rochester IN 46975. 219-223-6059.

CAMERAS (VIDEO)

Want to Sell

JVC BY-110 3-tube camera w/case, (2) batteries, pwr supply & charger, (2) cables, 10X lens, like new, \$2300/BO; (4) JVC 1-tube cameras S-6U, \$400 ea/BO. T Quinn, Monte Vista St, 208 Cherry, Capitola CA 95010. 408-475-0423.

Ikegami 79D excel cond, just overhauled, \$6000; Sony Betacam portable studio cams, excel cond, \$6000 or \$10,000 for both. Ugly George, 212-677-2200, M-F, 9-5; Fax 212-941-0956, M-F, 9-5.

Sharp XC-700 3 tube w/access, retubed, \$2000/BO; (4) JVC S-62U, 1 tube, \$600 ea or BO; JVC 2 KY-2700 3 tube w/14x1 zoom, \$1800/BO; Sony DXC 1640 1 tube, \$800/BO; Sony DXC 1610. T Quinn, Monte Vista Sts, 208 Cherry, Capitola CA 95010. 408-475-0423.

Panasonic WV-555B, complete ENG package, brand new, \$2500; JVC KY-1900, complete ENG package, \$1450. R Lawrence, Moonshadow Video, 4280 Reston Rd, Roseburg OR 97470. 503-679-8966.

JVC KY310, Fujinon 12x1 lens w/2X extender, AC adapter/charger, battery, cable, gd cond, \$2295; Panasonic WV6000 camera, 10x1 lens, AC adapter/charger, battery, cable, case, like new, \$1095. D Brennan, Brennan Custom Video, 3596 Lorna Ridge, Birmingham AL 35216. 205-823-0088.

JVC BY-110 3 tube color camera, like new, pwr supply, case, (2) batteries, pwr supply & camera cable, shop manual, \$2200/BO. T Quinn, 208 Cherry, Capitola CA 95010. 408-475-0423.

Ikegami ITC-2405 (2), 3-tube saticon cameras, complete w/lens, cables, CCU, \$2000 ea/\$3500/both. L Mintzmyer, KOOD, 6th & Elm, Bunker Hill KS 67626. 913-483-6990.

JVC KY210 3 tube camera, low hrs, mint cond, all extras, \$3500. Jack, 203-264-3666.

Sony DXC-M3 (2), 3-tube cameras, excel cond, ea has Canon 15X bdct lens, complete w/case, charger, field battery pack & extras. D Kahn, TV 33, 601-21 Newark St, Hoboken NJ 07030. 201-659-1700.

Sony BVP-30 w/CA-30L, Fuji A14X9 berm, BVF-50 viewfinder, RM-P3, BVW-25, BVM8021, O'Conner mdl 50 system, all excel cond, low hrs, call or write T Wagner, USAR, 512 S Hanley, Ste 90, St Louis MO 63105. 314-567-6777.

JVC BY110 3 tube camera w/S-VHS upgrade, Fuji 16x zoom lens, MK50 shotgun mic & optional KAM-50 mic grip, A/C adapter-charger, (2) DC11U nicad batteries, VF400 4" B&W studio viewfinder, studio zoom & focus controls, (2) cables, custom case, high resolution & a top quality performer in like new cond, \$3695. B Hines, IPS, Rd 1 Box 413A, Export PA 15632. 412-468-4115.

CEI 310 color camera w/CCU w/rear zoom controls, etc (2), \$2000. J Fuehrer, NTV Network, POB 220, Kearney NE 68848. 308-743-2494.

Panasonic WV-777 3-tube camera, ENG configuration 12 x 1 lens w/(2) NiCad batteries, (2) chargers, hard case, A/C adapter, operators manual, service manual, 4-pin DC input adapter, \$3500. B Marshall, Instant replay Video, 3836 Harvey, Western Springs IL 60558. 708-246-3110.

IVC-240 film chain incl CCU and camera junction unit, must be picked up in Tulsa, OK, FREE. R Hardy, 3239 S 90th East Avenue, Tulsa OK 74145-1661. 918-627-2937.

Norelco PC72, PC70, PC970, color cameras, 15-1 lens, lots of parts, yokes, etc. BO. H Larson, Matrix TV, POB 536, San Luis Obispo CA 93406. 805-544-5657.

Sony VO-2860A (2) w/Micro-Loc, \$600 ea; Universal wooden field tripods (2) w/guid heads, 1 spare head, \$350 ea. all in gd cond. J Romeo, Comm Christian Network, POB 84395, Vancouver WA 98684. 206-254-2976.

Sony AVC-3260DX B/W video camera w/monitor viewfinder, \$100 plus shpg. M Holwin, Anamnesia Studios, 40 South Oxford Street, Brooklyn NY 11217. 718-852-7630.

Sony BVW3 Betacam tube camera w/12 extender, Fuji lens, BWI recorder & access, both recently serviced & in gd working order, \$11000. J McBride, Box 464, Osceola IA 50213. 515-342-6536.

Want to Buy

Dumont, RCA, GE old tube type TV cameras, image orthicon & iconoscope type. A Weiner, Britton, Monticello ME 04760. 207-538-9538.

Old RCA, Dumont, GE, early TV camera equipment. A Weiner, Britton Rd, Monticello ME 04760. 207-538-9538.

CART MACHINES

Want to Sell

BE/Spotmaster TP-1A cart winder, without timer, \$100, will throw in 100 plus carts for \$150; (3) record amps, mono, for RCA RT-27/BA-27 series cart machines, \$40 ea. F Vobbe, Great Northern Bdct Co, POB 5031, Lima OH 45802. FidoNet 1.234/16.

BE cart tape winder, almost new, w/timer, both in original packing, \$425. G Cahill, Invisible Inc, POB 5786, Hudson FL 34674. 813-725-5003.

3M/ITC Delta I stereo, gd cond. E Trevino, KBOR, Box 3407, Brownsville TX 77523. 512-541-6348.

BE 303C 3 deck mono, works, \$250. T Devine, WVLC, 300 W Vine, Lexington KY 405077. 606-253-5900.

ITC RP mono, 3 tones, mint cond, \$1100; ITC RP w/network delay, excel cond, \$1250; ITC SP, 3 tones, new heads, \$575; (3) ITC RA's, 3 tones, \$550 ea; ITC RA, 1 kHz tones, \$500; B&H oscil, \$75; relapped mono cart machine PB heads, \$70; stereo PB cards, 3 tone Q cards, rack mounting ears, relays & other small parts for ITC Premium series cart machines. M Brown, 503-245-4884.

Tepecaster 700RP R/P. (2) Tepecaster 700P & a 700XP cart player, all in vgc & clean, \$1000/all includes shipping. B Mounjo, WIDD, POB 1240, Elizabethton TN 37644. 615-543-5849.

Tepecaster 700RP; (3) 700P; 700R/P; (2) 700P; 700XP cart decks, gd cond, \$1000/all; Otari MX5050B, \$900. B Mounjo, WIDD, POB 1240, Elizabethton TN 37644. 615-543-5849.

Fidelipac CTR 12 stereo cart machine, \$1000; Allied A1 500 N cart rack, \$374. T Teagarden, KELI, POB 3834, San Angelo TX 76902. 915-655-9879.

BE Spotmaster 1070 RP, gd cond RP (2), low hrs, workhorse, original packing, \$350 ea or \$650/both. R Robbins, Box 1079, La Conner WA 98257. 206-445-6616.

Spotmaster carwinder w/imer, \$350. C Benner, WUSL, 440 Domino, Phila PA 19128. 215-483-8900.

ITC WRA Series stereo ITC 3 tone record unit, excel cond, BO. C Miller, Studio VU Prod, 4722 Pochontas Ave, San Diego CA 92117. 619-270-6908.

ITC RP stereo new heads, all tones, excel cond, \$1200 pls shpg. P Woods, WPEG, 520 Hwy 29N, Concord NC 28025. 704-333-0131.

ITC RP w/network delay, excel cond, \$1250; (3) ITC RA's, 3 tones, \$550 ea; ITC RA, 1kHz tones, \$500; ITC RA, missing case, \$375. M Brown, 503-245-4889.

Sono-Mag 350 RS (2) 6 yrs. old, both in gd cond. \$800/ea. or 2/\$1500 pls. frt. cst. B Weeks, P.O. Box 107, B Falls VT 05101. 802-722-4890.

Spotmaster BED-17 RP single deck mono, gd cond, \$250; ITC standard record electronics, stereo, gd cond, \$450. G Gardner, KLGQ, 243 W Main, Delta UT 84624. 801-864-4423.

Audio-cord E-series (1) w/record/play/stereo & w/1 playback unit-mono, gd. cond. \$1200. B Weeks, P.O. Box 107, B Falls VT, 05101. 802-722-4890.

Motor w/capstan for ITC 3 deck, cond unknown; manuals for ITC 3 deck, \$100; Collins PB-190 rack mount, gd for parts, BO. D Niccum, KOZA, 1301 S Crane, Odessa TX 79760. 915-333-3101.

ITC Premium RP, limited use, \$900. F Lauerman, WMAM, Marinette WI 54143. 715-735-6831. 3-5 CDT.

Macarta 57211 RP for use or parts, BO. D Aase, KHHT-FM, Box 1666, Minot ND 58702. 701-852-0361.

ITC Premium SP (2), mono, gd cond, new steel cases, \$625 ea; Audicord A Series (2)

BEE

THE HALL Electronics

THE BEST DEALS ON QUALITY REBUILT & BRAND NEW BROADCAST EQUIPMENT
We BUY & TRADE equipment too!
Please phone or send for our latest flyer.

10:00AM-6:00PM EST

804-974-6466

1305-F Seminole Trail
Charlottesville, VA 22901

RECORDERS . . . WTS

Otari 5050B2 7.5 & 1.5 ips 2 trk, less than 1 yr old, excel cond w/manual, \$950/firm. S Mahaffey, Mahaf Prod, 3592 N Delsea Ste 12, Vineland NJ 08360. 609-692-3439.

Recordex 3301I cassette duplicator, 1 master & 3 slaves, 16X duplication speed, automatic rewind, erase heads, long-life Vikor record heads, LED level meters, \$700/BO. G Curry, Int'l Ministries, 4725 Peachtree Corners Circle Ste 250, Norcross GA 30092. 404-449-6766.

Studer PR 99's, play only tape decks (8) 2.5 yrs old, balanced audio output, gd working cond, w/capstans recently replaced, rack mounts, speeds 1.875 & 3.75. Also (2) 25 Hz Conex tone detector panels each w/409 detectors, manual, package price \$10,500 or BO.
Call Bruce LaRose, 201-750-9210.

Ampex 601 tape transport, as is, for parts \$30; (3) Rotron 115 V Whisper fans for equipment cooling, \$10 ea or \$25/all, E Welch Welch Media, POB 1455, Moncks Corner SC 29461. 803-761-7585.

Crown SX844 4 chnl 1/4", like new, \$850; Crown SC844 variable speed 4 chnl 1/4", mint cond, \$1200; Magnecord 1022 4 head, 1/2 trk stereo RP, 4th head 1/4 trk play, mint, \$300, J Parsons Sr, Parsons Electr, 10375 Cannas, N Huntingdon PA 15642. 412-863-9590.

Tascam 122 fairly new, \$600. E Trevino, KBOR, Box 3407, Brownsville TX 78523. 512-541-6348.

Ampex ATR 800 (6) 1/4" stereo R/P, excel cond, manuals, \$2400 ea or \$13,000/all or BO. V Kilion, KRNV, POB 880, Lexington NE 68850. 308-324-6717.

Ampex 1200 24 trk matched pair, all the mods, great shape, heads have been lapped, many spares, \$30K/pr, will consider 15K ea breaking set. D Hewitt, Remote Record, Box 334, Lahaska PA 18931. 215-794-5005.

Revox B77 excel cond, \$1000/BO. D Johnson, J-Con Ld, 200 E Racknet Club, Ste 31, Palm Springs CA 92262. 619-323-4399.

Revox PR-99 (4) w/Persons Programmer 3A, mint cond, BO. J Phillips, WZOM, 409-1/2 Clinton, Defiance OH 43512. 419-784-1059.

Ampex ATR 800 roll around consoles (2), \$200 ea; Kavouras Radac 500 color radar, 120 & 240 mile range, phone dial-up access, low hrs, \$5000/BO. V Kilion, KRNV, POB 880, Lexington NE 68850. 308-324-6717.

Teac X-2000R 10.5" 1/4 trk, 7.5-3.75 ips, dbx, bi-directional 6-head system, auto-locator, 3-motor transport, very low hrs, excel cond, \$1000. G Curry, Int'l Ministries, 4725 Peachtree Corners Circle Ste 250, Norcross GA 30092. 404-449-8766.

Scully 1/2 trk tape heads (28) play: (12) mono Magnacord Presto, play; (16) Magnacord stereo lapped Presto, play, sacrifice price. Call 616-782-9258.

Denon DN950F cart-CD player, new in box, \$1000; (2) ADC Pro Patch chassis PPA-3-18, Mark II, NO, new, \$500 ea; ADC Pro Patch assembly BJF 104-4, Mark II, new, \$500. J Perez, 1901 Amy, Santa Rosa CA 95401. 707-526-5050.

Tascam Series 8 trk studio equip, including 80-8 recorder, DX-8 dbx unit, M-35 board, A-3300SX 2 trk master, much more, \$12,000. R Bolling, POB 493, Pound VA 24279. 703-796-5146.

Teac A-170S, top load cassette recorder w/Dolby, gd cond, \$75; Teac R-435X auto-reverse w/Dolby B & C, dbx, metal, record mute, microphone inputs, like new, \$150. L Hoover Jr, Logical Audio Solutions, 325 Saude, Essington PA 19029. 215-521-2933.

NORTRONICS Replacement Tape Heads

Test Tapes, Degaussers, Gauges
 Cleaners, Swabs, Lapping Films
 Splice Bars/Tabs, Demagnetizers

SEQUOIA ELECTRONICS

1131 Virginia Ave
 Campbell CA 95008
 (408) 866-8434

Magnecord N35B portable, w/manual, excel cond, \$75. A Smith, Smith Sound, 52 Summer, Westboro MA 01581. 508-841-2209.

Technics RSB-85 w/dbx, 3 heads, Dolby B & C, \$275. S Chapekis, POB 22122, Denver CO 80222. 303-721-9156.

Akai 4000DS MK II in excel cond, needs reel retainer for supply reel, \$300. T Devine, WVLK, 300 W Vine, Lexington KY 40507. 606-253-5900.

Teac A-3300SX 1/2 trk, vgc, almost new heads, 7.5 & 1.5 ips, 10" reel capability, remote, \$450. J Block, The Prod Block, 906 E 5th, Austin TX 78702. 512-472-8975.

Denon DRM-33 3 hrs, Dolby B & C, \$200. S Chapekis, POB 22122, Denver CO 80222. 303-721-9156.

Yamaha K-960 w/Dolby B & C, dbx, metal, memory rewind, timer, record mute, mic inputs, vgc, \$225. L Hoover Jr, Logical Audio Solutions, 325 Saude, Essington PA 19029. 215-521-2933.

Ampex 602 & 622 speaker/amp, excel cond, except PB head has developed an open circuit, \$100. A Smith, Smith Sound, 52 Summer, Westboro MA 01581. 508-841-2209.

Ampex AG-350 FT in roll around, \$350; Ampex 351-2, reproduces only, solid state, \$250; Liberty CW-20 cart loader, BO; Electro Sound ES 100-48C cart & cassette loader, BO. D Lundy, POB 408, Heidrick KY 40949. 606-546-6650.

Ampex 351 tube-type electr, modified for Sel-Syne, T Boddie, 12202 Union, Cleveland OH 44105. 216-752-3440.

Ampex 601, 1/2 T machine in excellent condition; \$100. W Dudley, 6919 19th Street, Tampa FL 33610. 813-237-6516.

Tascam 122 MK2 4 trk, 2 chnl stereo, less than 10 hrs, \$700. R Meadows, Southeastern Sports, 1203 Seaton Rd #117, Durham NC 27713. 919-544-1366.

Revox B77 factory sealed, never used, \$1400/BO. P Malkinson, 5000 14th Street NW, Washington DC 20011. 202-726-1742.

Crown SX844 3 speed 4 chnl, 1/4, mint cond, \$850. J Parsons, Parsons Electronics, 10375 C Annas St, North Huntingdon PA 15642. 412-863-9590.

Telex CD2MS & CD25 master duplicator, plus slave unit, high speed duplicator, mono, commercial quality, \$1700. R Meadows, Southeastern Sports, 1203 Seaton Rd #117, Durham NC 27713. 919-544-1366.

Otari MX5050 2SHt w/remote control & hubs, excel cond, \$1200/BO. J Miller, 908 Frontview, Dodge City KS 67801. 316-227-4444.

STUDER REVOX

FACTORY AUTHORIZED SERVICE CENTER

"SUPERLATIVE SERVICE"

Swiss trained in servicing all open reel & cassette tape recorders, CD players, & other Studer/Revox equipment. Over 12,000 units serviced Nationwide since 1978. Fast 48-hr turn service w/90 day warranty. Huge parts inventory. Capstan shaft resurfacing & head relapping service. New & used machines available w/warranty. Visa/MC.

STUDIO-SONICS CORP.
 2246 N. Palmer Dr., #100
 Schaumburg, IL 60173
 Phone: (708) 843-7400
 FAX: (708) 843-7493

Kenwood KX-720 top load cassette recorder w/Dolby, gd cond, \$75; Sony TC-660 auto-reverse w/built-in amp & speakers, gd cond, \$200. L Hoover Jr, Logical Audio Solutions, 325 Saude, Essington PA 19029. 215-521-2933.

Teac A3440 4 chnl w/warranty, new, BO. G Chapekis, POB 22122, Denver CO 80222. 303-721-9156.

Tascam EM 1542, new reel motor for Tascam 38 deck, \$75. J Roper, Imperial Snd, RR 31 Box 405, Terre Haute IN 47803. 812-877-2663.

Studer Revox B77 1/4 trk, excel cond, \$675. R Herman, Frontier Radio, POB 9292, Austin TX 78766. 512-280-5691.

Sony DTC-1000ES U.S. mdl DAT machine, like new, BO. R Kaufman, PAMS Prod, POB 462247, Garland TX 75046. 214-271-7625. Aft 2PM CST.

Technics 1506 2 trk record, 2/4 trk PB, direct-drive quartz-lock, low hrs on head, vgc, \$600. Alan, Calvary Baptist Church, 1380 Valley Forge Rd, Lansdale PA 19446. 215-368-4444.

teac Synacast 124, \$200 pls UPS. N Mishan, POB 335, Lynbrook NY 11563. 516-582-1338.

Ampex AG-40B 1" 8 trk roll-around console, gd cond, BO. R Kaufman, PAMS Prod, POB 462247, Garland TX 75046. 214-271-7625. Aft 2PM CST.

CLEAN PATCH BAYS NO DOWN TIME



VERTIGO BURNISHERS AND INJECTORS RESTORE ORIGINAL PERFORMANCE TO YOUR PATCH BAYS

\$29.95 Ea. Plus \$1.00 for shipping and handling.
VERTIGO RECORDING SERVICES
 12115 Magnolia Blvd #116
 North Hollywood, CA 91607 818-907-5161

Intonics 200 Series cass Dup 1-10' RR master, 1-4 pos. slave (2), \$1500/ea. T Boddie, 12202 Union, Cleveland OH 44105. 216-752-3440.

Uher 4000 Report-L in good condition with all acc.\$30. W Dudley, 6919 19th Street, Tampa FL 33610. 813-237-6516.

Tascam 38 1/2" 8 trk, low hrs, excel cond, \$1875; K Flory, The Production Co, Box 1027, Siloam Springs AR 72761. 501-524-4626.

Revox PR-99 (4) used very little, \$5000 or BO, J Phillips, WZOM-FM, 4081/2 Clinton, Defiance OH, 43512. 419-782-8591.

Otari ARS-1000 (2) 6 yrs. old, gd. cond. \$1000/ea. or 2/\$1600. B Weeks, P.O. Box 107, B Falls VT, 05101. 802-722-4890.

Sony TC-640 7" 1/4 trk stereo reel, vgc, buyer pays shpg, \$50. W Laughlin, 753 Ruth Ln, Hurst TX 76053. 817-282-9033.

Revox PR99 (2), \$650/ea. Mr. Hays, 505-397-4969.

Ampex 440-B (2) in roll-a-bout consoles, low hrs, excel cond, stereo 2 trk, \$1750 ea; Scully/Metrotech slow loggers (2), gd cond, on air use thru April, \$395 ea. B Lunderville, Radio New England, 75 Gardner, Hingham MA 02043.

Ampex and Scully Spare Parts, Accessories, Motor Remanufacturing.

VIF INTERNATIONAL

PC Box 1555
 Mtn View
 CA 94042
 Direct line 800-848-4426
 in CA Dial (408) 739-9740
 Telex 62922869 ESL UD
 FAX 1-408-739-0809

Studer Revox HS-77 Mk IV FT mono, 15/75 ips, wood case, mint cond, \$750/BO. R Katz, 15015 Ventura Blvd, Sherman Oaks CA 91403. 818-377-5264.

Tascam 122 MK II 4 trk, 2 chan stereo (2), \$600/ea. R Meadows, 1203 Seaton Rd #117, Durham NC 27713. 919-544-1366.

Revox A700 2 trk stereo, 3 speed, new heads, excel cond, \$950. B Barry, WAMB, 1617 Lebanon Rd, Nashville TN 37210. 615-889-1960.

Crown SX844 Vari Speed 4 chnl, 1/4, 15/16 to 15 ips, mint cond, \$1200. J Parsons, Parsons Electronics, 10375 C Annas St, North Huntingdon PA 15642. 412-863-9590.

Studer Revox port case for A77 w/mn spkrs & pwr amps, exc cond, \$295/BO. R Katz, 15015 Ventura Blvd, Sherman Oaks CA 91403. 818-377-5264.

Marantz PMD221 mono tape recorders w/carrying cases (3), \$100/ea. R Meadows, 1203 Seaton Rd #117, Durham NC 27713. 919-544-1366.

AIWA ADR450 auto-reverse cassette deck, \$50 plus shpg. M Holwin, Anamnesia Studios, 40 South Oxford Street, Brooklyn NY 11217. 718-852-7630.

Nagra IV-S no manual, power cord, stereo, battery operation, BO over \$1000. S Wytas, 165 Linden, New Britain CT 06051. 203-224-1811.

Technics RS-1506US isolated loop, direct drive, quartz lock, IC logic control RR deck. 2-track R/P plus 4-track play head, gd cond, \$500. A Allegra, 1380 Valley Forge, Lansdale PA 19446. 215-368-4444.

Telex 341 cassette duplicator, high speed, does 3 slaves from master, \$500. R Meadows, Southeastern Sports, 1203 Seaton Rd #117, Durham NC 27713. 919-544-1366.

AUDIOPAK CARTS PANCAKE TAPES REELS & BOXES CUSTOM LOADED CASSETTES

You want product, price and delivery? We've got it. Call today. We want to win your business. Let us prove it.

NORTHWESTERN
 503-726-0170
 1-800-547-2242
 Fax 503-726-7907

Marantz PMD 221 (4) mono, portable w/carrying cases, \$100/ea. R Meadows, Southeastern Sports, 1203 Seaton Rd #117, Durham NC 27713. 919-544-1366.

Otari ARS1000 7.5/15 ips, stereo playback deck w/25 Hz detector, gd cond, \$850. R Ker-bawy, Box 1127, Beckley WV 25802. 304-877-5592.

Otari DP-4050-Z3 slave cassette duplicator, makes 3 copies per pass at 8 to 1 speed, like new, used about 25 hours, \$2995. C Richardson, 1938 Baltimore Annapolis Blvd, Annapolis MD 21401. 301-757-3733.

Otari 5050B very clean, low hours, \$1650. G Gaskey, Box 158, Weed CA 96094. 916-938-3828.

Scully '100' recorders, record/play amplifiers, 8, 16, 24 track heads. Sequoia Electronics, 1131 Virginia Ave, Campbell CA 95008. 408-866-8434.

Want to Buy

Tascam 70 4 or 8 trk in working cond, also parts & manuals. R Barrett, Inner City Prod, 5539 E Burnside, Portland OR 97215. 503-234-6225.

Sony TC 788-4 4 trk in gd cond & w/maintenance manual. C Fuller, Voices, POB 153, LaGrange IL 60525. 312-579-9578.

Multi-track R-R or porta-studio in gd cond for small market studio, affordable price. Call 314-998-2377 or write: WLD Recdg, W Dougherty Jr, Rt 1, Music Valley, Mill Spring MO 63952.

High speed cassette duplicator mono or stereo to record 10 at one time in working cond, need not be Elabrite. R Sweatte, KXKR, 600 Bdwy Ste 220, Kansas City MO 64105. 816-421-1065.

Teac A7030S6, A7030GSL, A3300SX & broke/poor cond machines for parts. J Parsons Sr, Parsons Electr, 10375 Cannas, N Huntingdon PA 15642. 412-863-9590.

Teac 80-8/3440 remote controls, punch in foot switch record, play, FF, rewind, stop features, will pay shipping. J McCallum, McCallum Rec Fac, 3311 Bruce Randolph, Denver CO 80205. 303-399-8548.

Tape reel hold downs for Ampex 300, 351, 302, 354, AG440 MR 70, etc; power cords for Ampex 351 & 354, AG440, P Hons, Mainline Comm, 106 Poplar, Portage PA 15946. 814-736-3883.

Fostex B-16 16 trk recorder. M Sokol, JMS Prod, 121 E Baltimore, Hagerstown MD 21740. 301-791-2568.

Inovonics 355 & 900 PS RP 2 chnl amp, must have xformers in play & sync cards. L Beigel, POB 85042, LA CA 90072. 213-466-3595 or FAX 213-466-3596.

3M 850, need not work, any cond OK but must have tension arms, need for spare parts. J Lombardi, Island Video, 182 Fairchild, Plainview NY 11803. 516-349-0333.

Otari 5050 in gd cond, late mdl. K Hedge, Box 351 Pulaski VA 24301. 703-980-2702.

Teac A7030SL, A7030GSL, A3300ST, A3300S, J Parsons, Parsons Electronics, 10375 C Annas St, North Huntingdon PA 15642. 412-863-9590.

Ampex MR-70 2 trk stereo or mono machine, will consider transport only for parts. C Richardson, 1938 Baltimore Annapolis Blvd, Annapolis MD 21401. 301-757-3733.

Otari/Revox stereo 2/4 trk needed for production, must have vari-speed, and 10.5 reel capability, must be in gd cond. T Murray, 100 W 9th Street #306, Rochester IN 46975. 219-223-6059.

Teac/Tascam 35-2 or 35-2B 2 trk in working cond, minor repairs needed. W Ahlberg, 11846 Ventura Blvd #306, Studio City CA 91604. 818-509-9100.

Ampex ATR-700 rack mounts for ATR-700. W Slaten, 424 Grant, Scotch Plains NJ 07076. 201-322-4466.

Viking/Telex RP84 or RP85 electronics. J Parsons, Parsons Electronics, 10375 C Annas St, North Huntingdon PA 15642. 412-863-9590.

ATR100 taperecorders for parts. Circuit cards, heads, motors, machine parts, or electronic parts. Call 818-907-5161.

MCI/Sony capstan & reel motors, any cond., recdg heads, most mfgs, machines, new, used. Relapped then sold. Amp Services, 224 Datura St No 614, W Palm Beach FL 33401. 800-826-0601, in FL 305-659-4805.

CONSOLES

Want to Sell

Ramsa WR 8112, 12x4x2, \$1500. C Green, Century 21 Programming, 800-937-2100.

Harris Micromac 16 input mainframe, manuals, spare pwr supply, \$10,000/BO. V Kilion, KRNV, POB 880, Lexington NE 68850. 308-324-6717.

Midas Pro Custom Recording, 16x8, Remix switch-over, (8) Pro 5, (8) Pro 3 modules, peak meter, clock/timer, flight case, \$10,500. H Alrich, Box 869, Greenville CA 95947. 916-284-6929.

RCA BC8A dual mono console, clean shape, \$500 plus crating & shipping. J Kreines, DeMott/Kreines Films, 5330 Kennedy, Millbrook AL 36054. 205-285-6179.

BE 4BEM 50 w/4 pots; (2) Ramko solid state; Collins 212 F-2 tube type w/6 pots; AT1 8 chnl stereo w/pwr supply, call for details. Adolph, 915-949-2112.

Tascam M520 mixer (New)	4550
Ramsa WR820 console (Demo)	4950
AK OLock 3.10 synch (New)	4990
AK Pacer synch w/pad (New)	2090
Tascam ATR60 TimeCode 2tk (New)	4890
Tascam AQ65 Autolocator (New)	750
Tascam 38 1/2" 8tk (New)	1890
Fidelipac 124 Stereo Cart Rec (New)	3190
Neumann KM83 mics (New)	329
Neumann 48V power supplies (New)	169
Fostex M88 Ribbon Mic (New)	359
Comtek Wireless Mic w/Lav (Demo)	759
ADA Harmonizer (New)	359
TrippLite 1000W inverter (Demo)	329
Audio-follow-Voice Switcher (Used)	270
AKAI S900 8-voice Sampler (New)	1390
Altec 604-8C Ref Monitors (Used)	498

Call TRAX (801) 262-3601

Sunn Magna 5000, 24 inputs, 4 outputs, 3 aux sends, 3 band, 5 frequency EQ, Duncan faders & (2) spare modules & case, \$3300. B Petruzzi, Rouse St Prod, 804 E Old Hickory, Madison TN 37115. 615-868-8516.

Tascam M-520 20 chnl, mint cond, 6 mos old, \$4250. D Miller, Airborne Audio, 11647 W 83rd Terr, Lenexa KS 66214. 913-492-8822.

Interface 104L 16x8 monitor mix console, 9 freq, 3 band EQ pads, solos, etc, \$950. B Petruzzi, Rouse St Prod, 804 E Old Hickory, Madison TN 37115. 615-868-8516.

Autogram AC-6 6-channel 1/2" input stereo console, excel cond, includes ES built-in timer, \$3000/BO pls shpg. D Kelley, KISZ, POB 740, Cortez CO 81321. 303-565-1212.

ADM ST-160 16 input stereo w/turntable, photos avail, \$6000/BO. J Bretner, WDFX, 306 S Washington, Royal Oak MI 48067. 313-398-1100.

Gates Stereo Statesman, 5 chnl audio board in working cond, (2) modules missing, \$500; Robins 7 chnl custom board, 3 mic channels, 4 line channels, stereo, \$500. R Long, North-western College, 3003 N Snelling, St Paul MN 55015. 612-631-5312.

CONSOLES . . . WTS

Tascam M320 20 input, 4 buss, 8 monitor, mint cond, \$2700. S Wytas, 165 Linden, New Britain CT 06051. 203-224-1811.

Quantum QM-8 8 inputs, 4 busses, quad 8 stereo mon, lrg triad input xmtrs, audiophile snd, Duncan linear faders, exc cond, \$850/BO. R Katz, 15015 Ventura Blvd, Sherman Oaks CA 91403. 818-377-5264.

Russco 505S good shape, just re-worked w/manual, \$500/BO. V Richardson, 1024 College, Jackson KY 41339. 606-666-4946.

Yamaha MC-1204 12 inputs, EQ w/parametric midrange, phantom mic power, \$1500. G Desoto, 1117 E El Paso Ave, Fresno CA 43710. 209-432-0937.

Tascam M216 16 ch input, 4 subgroup stereo, parametric mid band EQ, exc cond, \$950. D Lasko, 3054 Gold Canal Ste D, Rancho Cordova CA 95670. 916-638-7770.

Speck 16 inputs, 8 busses, outboard ps, easily port, exc cond. \$850/BO. R Katz, 15015 Ventura Blvd, Sherman Oaks CA 91403. 818-377-5264.

Audio Technics AT4462 6 ch portable mixer, operates on 4 9 volt batts, +BU stereo balanced output, osc. adjustable limiter, intercom system, \$750. D Lasko, 3054 Gold Canal Ste D, Rancho Cordova CA 95670. 916-638-7770.

Want to Buy

WE, RCA, Langevin mixers/consoles; also amps, speakers, mics, transcription players, literature. R Van Dyke, Squires Ave, E Quogue NY 11942. 516-728-1327.

Gates Executive program amp module M5700. R McDaniel, KJRG, 209 Meridian, Newton KS 67114. 316-283-5150.

McMartin B-1082 8 chnl stereo board. L Nelson, WSPY. 708-552-8985.

RCA & WE tube consoles, mixers, amplifiers, speakers, mics, literature. R Van Dyke, Caffrey House, Squires Ave, E Quogue NY 11942. 516-728-1327.

Harris Stereo 80. G Elder, PO Box 869, Covington GA 30209. 404-786-1430.

DISCO & SOUND EQUIPMENT

Want to Sell

Alesis Midiflex & Midiverb & rack unit, (2) complete stereo digital effects units in a 1-rack space package, barely used, sell package or separately, \$450/BO. W Sams IV, 13009 Pardue Pl, Tampa FL 33617. 813-988-2449.

Yamaha NS-10 monitors, one pr still boxed, one pr opened, black, 2-way speaker monitors, as new, BO; JBL 4312 monitors, 3-way speakers, like new, \$400 ea. Mr Keith, ALI, Box 313, Keene NH 03431.

Rane AC-23 3-way stereo, 5-way mono active crossover w/time correction, barely used, will trade for AC-22 or equivalent in comparable cond. \$300. W Sams IV, 13009 Pardue Pl, Tampa FL 33617. 813-988-2449.

Eventide H-910, Harmonizer, gd cond, \$850. L Hoover Jr, Logical Audio Solutions, 325 Saude, Essington PA 19029. 215-521-2933.

EV SH-1502ER (2) two-way loudspeaker, 15" woofer, high freq horn in carpet covered cabinet w/handles & metal corners, 5 yr warranty, \$600/pr. B Fisher, KPOK, POB 477, Bowman ND 58823. 701-523-3883.

Klipsch La Scala speakers, Klipsch horns, road cases, fiberglass finish, excel cond, BO. R Kaufman, PAMS Prod, POB 462247, Garland TX 75046. 214-271-7625. Alt 2PM CST.

Fairchild 641 stereo Mastering Disc Sys 740 modification, BO. P Cibley, 138 E 38 St, New York NY 10016. 212-986-2219.

EV Sentry II control monitors, walnut, excel cond, \$200/pr. D Lundy, POB 408, Heidrick KY 40949. 606-546-6650.

Linn LM-2 drum machine w/UL Cooper midi modification, BO. P Cibley, 138 E 38 St, New York NY 10016. 212-986-2219.

Snake 16 phantom-pwr inputs w/lex ps, 250' Belden 19-pair cable w/mil connectors & stainless steel strain reliefs, 10' Neumann XLR snake mates w/box or Belden snake, exc cond, \$850/BO. R Katz, 15015 Ventura Blvd, Sherman Oaks CA 91403. 818-377-5264.

Want to Buy

Ibina MSP-1000 limiter-EQ-notch finder, D Wade, Collegium Sound, 35-41 72nd, Jackson Hts NY 11372. 718-426-8555.

JBL 4315, 4333,4343 Loud speakers. R Glenn, 1718 Shenandoah Road, Wimauma FL 33598. 813-634-1940.

LIMITERS

Want to Sell

Harris M-6144 dual stereo w/manual, \$40. P Russell, Bowdoin College, Brunswick ME 04011. 207-725-3066.

Harris MSP 90, studio end works fine, xmtr end needs work, BO; DAP 310 AGC peak limiter, has been updated, BO. T Rusk, KITA, 723 W 14th, Little Rock AR 72202. 501-375-1440.

CBS Labs 411 stereo Volumax, \$300; CBS DPE 4500 units (pair), \$500. C Benner, WUSL, 440 Domino, Phila PA 19128. 215-483-8900.

Aphex stereo compellor, 750; CRL SEP 800, \$1550; Robert Jones translator, \$1500. P Posen, KEZN, 72-915 Parkview, Palm Desert CA 92261. 619-340-9383.

DAP 310 & Harris MSP90, 310 has been updated, MSP90 AGC & limiter studio end working, xmtr end needs work, \$1000/all. T Rusk, KITA, 723 W 14th, Little Rock AR 72202. 501-375-1440.

Orban Optimod-FM 8100A/1 Perfect condition, factory specs. \$3000. R Rocks, 27 N 27th Street, Billings MT 59101.

Orban 424A compressor limiter, BO. R Hays, KYKK, 619 N Turner, Hobbs NM 88240. 505-397-4969.

Orban 8000/A excel cond, \$1400. P Swint, KIXQ, 2620 Dogwood, Joplin MO 64802. 417-624-1310.

ELECTRON TUBES • F.P. FILTER CAPS
SOCKETS • PARTS
Catalog—\$3.00
Kurluff Enterprises
4331 Maxson Rd., El Monte, CA 91732
(818) 444-7079
FAX: (818) 444-6863 Charlie Dripps

Texar RFC-1 FM Optimod #5 card, \$300. R Rocks, 27 N 27th Street, Billings MT 59101.

Metron 506B-1 Amplitude modulation monitor, gd. cond. \$300. C Raffiffe, #1 Radio Street, Wadesboro NC 28170. 704-694-2175.

Texar RCF-1 #5 card for Optimod, \$300. R Rocks, Box 1689, Billings MT 59103. 405-248-2681.

Orban Optimod 8100A/1-FM mint condition, \$3000. R Rocks, Box 1689, Billings MT 59103. 405-248-2681.

CRL AM APP 400, PMC 300A, SEP400B, SPF 300, NRSC compliant, in service 2.5 yrs, \$2500. M Tracy, KOAQ, PO Box 1263, Scottsbluff NE 68363-1263. 308-635-2899.

UREI 1176LN limiter, \$400 plus shpg. M Holdwin, Anamnesia Studios, 40 South Oxford Street, Brooklyn NY 11217. 718-852-7630.

Dorrough DAP-310 AM processor, all complete, working when removed, \$245. D Jack, Mtn. Media. 208-286-7676.

Gates/Harris limiter, AGG unit, \$300. G Elder, PO Box 869, Covington GA 30209. 404-786-1430.

Orban Optimod 8000 perfect cond, taken out of service 3/89, \$1500. P Swint/J Leutzinger, 417-624-1310.

QEI Stereo Peak Max 10715 limiter Good cond, w/manual; QEI 1073S stereo AGC amp, good condition, BO. V Clough, 225 Green St, Fayetteville NC 28302. 919-486-4991.

CRL FM System SPP-800, SEP-800, SMP-800, SG-800, CC-300A, excel cond, \$4500. T McNally, 1825 Murray Ave, Atlantic City NJ 08401. 609-344-0300.

Orban Optimod 8100A s/n 1408910, used less than 1 yr, pristine wall accessories, \$4000 firm. S Schweiger, WXLO, 146 Worcester Center, Worcester MA 01608. 508-752-1045.

CRL AM NRSC pre-emphasis filter processor, type SPF-300, meets new FCC standards, mint condition, \$450. B Barry, WAMB, 1617 Lebanon Rd, Nashville TN 37210. 615-889-1960.

DAP 310 (2) audio processor in gd cond, \$450/ea. P Swint/J Leutzinger, 417-624-1310.

Want to Buy

Orban Optimods 8000A, 8100A, 8100A/1, 9000A, 9100A, 9100B. Hall Electronics, 1305-F Seminole trail, Charlottesville VA 22901. 804-974-6466.

UREI LA-3A or LA-4 prod compressor/limiters. R Kaufman, PAMS Prod, POB 462247, Garland TX 75046. 214-271-7625. Alt 2PM CST.

DBX 700 (2) for 23GHz STL sys. in gd cond.

MICROPHONES

Want to Sell

RCA 77DX, BO or trade for E-V RE-20s. D Kelley, KISZ, POB 740, Cortez CO 81321. 303-565-1212.

EV CO-90 tie clasp lavalier mic (2), like new, \$79 ea; Vega Orator III bodyback wireless mic systems w/directional tie clasp mic, like new, \$545. G Meyer, 231 N 2475 W, Provo UT 84601. 801-375-4074.

AKG N-60 tube condenser pwr supply, w/swap for Sony type CP-2, CP-3A, or CP-3B pwr supply. E O'Brien, RR31 Box 405, Terre Haute IN 47803. 812-877-2663.

RCA 77DX vintage ribbon mic, excel cond, BO; Neumann U-67 vintage tube mic, excel cond, BO. R Kaufman, PAMS Prod, POB 462247, Garland TX 75046. 214-271-7625. Alt 2PM CST.

RCA 77 DX mt. cond., matched pr. Also 44JR original babs. 7503 or BO. J Phillips, WZOM-FM, 40812 Clinton, Defiance OH, 43512. 419-782-8591.

Neumann U87 (2), excel cond w/AC pwr supply, \$2500. F Badeaux, Musik Factory, 1812 Procter, Port Arthur TX 77640. 409-982-7121. 8-4PM CDT.

Altec 639 complete w/yoke & cable stand mounting, gd ribbon, will trade for small dual trace scope. L Beigel, POB 85042, LA CA 90072. 213-466-3595 or FAX 213-466-3596.

Shure DY-2 w/Dazon floating stand, \$20 pls UPS. G Kirby, Marysville Bacs, 13613 US 36, Marysville OH 43040. 614-261-8871.

Electro Voice RE-20 never used, \$450. R Meadows, Southeastern Sports, 1203 Seaton Rd #117, Durham NC 27713. 919-544-1366.

Shure 330 ribbon bidirectional mic (2), \$175/ea. C Richardson, 1938 Baltimore Annapolis Blvd, Annapolis MD 21401. 301-757-3733.

Realistic Dynamic Uni-directional mics, \$40 ea or 3/\$100. R Meadows, Southeastern Sports, 1203 Seaton Rd #117, Durham NC 27713. 919-544-1366.

Shure SM-89 shotgun mic, new, \$495. C Richardson, 1938 Baltimore Annapolis Blvd, Annapolis MD 21401. 301-757-3733.

Electro Voice (3) 635 mics, \$50/ea. R Meadows, Southeastern Sports, 1203 Seaton Rd #117, Durham NC 27713. 919-544-1366.

Electro Voice RE-20 mic has never been used, \$375. R Meadows, 1203 Seaton Rd #117, Durham NC 27713. 919-544-1366.

Shure SM-89 shotgun mic, w/shock mount & kangaroo case, \$550/trade. D Lasko, 3054 Gold Canal, Ste D, Rancho Cordova CA 95670. 916-638-7770.

Telefunken Tube CM-61 very rare, uses std plug-in tube, mint cond w/custom ps, BO. R Katz, 15015 Ventura Blvd, Sherman Oaks CA 91403. 818-377-5264.

Neumann KM-88 rare 3-pattern w/micel capsule, hot-setup percussion mic, mint cond w/orig case, \$995/BO; Neumann KM-86 3-pattern, mint cond, \$750/BO; AKG D224E (2), unused, \$375/BO/each. R Katz, 15015 Ventura Blvd, Sherman Oaks CA 91403. 818-377-5264.

RCA ribbon mics including (1) 44BX; (1) 77D; BK-11; 74-B; (2) SK-46; Shure 330 ribbon; Dynamics (2) Shure 555W, \$60 ea; EV 611; EV 630; Astatic DN-HZ. Tracy Eaves, 615-821-6099 (evenings).

Want to Buy

RCA 44's, 77's, etc. any model working or not; WE 633 mics, etc. B Davies, Virgo Prod, 5548 Elmer, N Hollywood CA 91601. 818-761-9831.

RCA 44BX or 77's, vintage ribbon mics. R Kaufman, PAMS Prod, POB 462247, Garland TX 75046. 214-271-7625. Alt 2PM CST.

MISCELLANEOUS

Want to Sell

Extel AF-11 teleprinter (3), G Hofer, KJLT, POB 709, N Platte NE 69101. 308-532-5515.

Sprague EMI/RFI noise line filter assy, model JN17-23, rating 3 phase, 125 A, 440 VAC, new, \$125. A Emerald, KGGa, 8956 Swallow, Fountain Valley CA 92708. 714-962-5940.

Magnavox BM7622 12" composite computer monitor, 80x25 amber display, audio input for sound, like new, \$75. L Hoover Jr, Logical Audio Solutions, 325 Saude, Essington PA 19029. 215-521-2933.

Heavy duty road case, foam lined, 43.25" x 27.25" x 8" inside dimension, \$60. D Wade, Collegium Sound, 35-41 72nd, Jackson Hts NY 11372. 718-426-8555.

Potter & Brumfield KHP17D11 12 V DC relays, never used (approx 140). \$1 ea. T Devine, WVLC, 300 W Vine, Lexington KY 40507. 606-253-5900.

Dynaco PAT-4 transistor preamp, inputs: special, tape, head, phono, tape tuner, tape monitor w/high & low filters, vgc, \$125. L Hoover Jr, Logical Audio Solutions, 325 Saude, Essington PA 19029. 215-521-2933.

Extel AH/P11R teleprinter w/stand, like new, BO. J Anderson, WKCW, 2192 Hwy 72 East, Corinth MS 38834. 601-286-8451.

Radio Shack TRS-80 Mdl II includes 3 drive expansion unit, Okidata 82A lineprinter, working when removed, \$600/BO pls shpg. D Kelley, KISZ, POB 740, Cortez CO 81321. 303-565-1212.

Extel AF-11R teleprinter, needs some work, includes service manual & 79 rolls of printer paper, cond unknown, \$150/BO pls shpg. D Kelley, KISZ, POB 740, Cortez CO 81321. 303-565-1212.

Sales training video tapes (16), VHS format, 30 subjects covered. R Trumbo, KNLF, POB 117, Quincy CA 95971. 916-283-4144.

Finebilt record pressing plant, (2) semi-auto rec presses, steam boiler pumps, punches, extruders, trimmers, electro-plating sys, chemicals, supplies, etc. \$12,000. T Boddie, 12202 Union, Cleveland OH 44105. 216-752-3440.

RTI Cinescan II film editor, \$500; RTI film cleaner, \$200; Grass Valley 961 synac module, \$20. J Fuehrer, NTV Network, POB 220, Kearney NE 68848. 308-743-2494.

The Idea File

OVER 50
PROVEN
PROMOTIONS

- Increase Sales
- Motivate Salespeople

The Idea Company
P.O. Box 4466
Biloxi, MS 39535

Conex AS101 audio switchers (2) no lamps; (6) Conex AS401 remote controls, BO. D Eressy, 1457 Main Street West Chatham MA 02669. 508-945-4855 am.

Luxo LM-1 multipurpose arms, less base (4) in excel cond, \$50/all. T Devine, WVLC, 300 W Vine, Lexington KY 40507. 606-253-5900.

GE VHF monitor, one chnl w/cguard, 120 VAC, excel cond, \$75 pls UPS. G Kirby, Marysville Bacs, 13613 US 36, Marysville OH 43040. 614-261-8871.

Inventory of disposable items including CBS Volumax 400, Harris 994-7993-001 PB, Andrew connectors, Fidelipak Mastercarts, and much much more, too much to list. Call for details and prices. A Kaplan, 609 E Court, Seguin TX 78155. 512-379-2234.

Bud B25A trans-aire rack blower, 2 sp, rebuilt motor, spare filters, \$50 pls shpg; Blonder Tongue AMT-10 audio modulator for TV chn 10, new, \$75 pls shpg; Melco Labs MAX212 telephone system, excel cond, \$250 pls shpg. E Davison, Multiplex, 135 N Illinois, Springfield IL 62702. 217-787-0800.

Tektronix 4006-1 Display terminal RS 232 interface, exc. cond. \$150. P Beal, Burem Road, Rogersville TN 37857. 615-272-3900.

Paltex 57200103 A/B roll edit controller SN 1114, 42000. J Fuehrer, NTV Network, POB 220, Kearney NE 68848. 308-743-2494.

Music video library carefully mastered on 240 1" reels, excel quality. J Nightbyrd, LPTI Inc, 225 Congress Ste 307, Austin TX 78701. 800-333-2152.

Phasemaster T1200A2 110 amp 240 V phase converter, excel cond, automatic starts w/full load, \$6500. A Baxa, WAVV, 11800 Tamiami Tr E, Naples FL 33962. 813-775-9288.

Sony/Econco 6800 w/bag, 100 hrs, \$1700; Econco 6166A/7007 tube, \$1800. M Nowak, WKBK, 1390 Bagley, Alpena MI 49707. 617-356-3434.

SONEX-SOURCE
88 NONOTOCK ST.
NORTHAMPTON, MA. 01060
'Your Source for
Sonex Acoustical Foam'
WIN RIDABOCK
(413) 584-7944

Closing/Liquidating an AM station. All studio inventory, production room inventory, xmtr/lower equip inventory and lots of misc equip inventory must go. The list is too large to publish so please call for all the details & prices. J Clinton, WMLC, 601-264-7892.

GE Pacer VHF desk-top G/E base station on iter freq, old but works, w/desk mic, \$65 pls shpg; GE MVP PY portable radio on UHF freq, no battery, works (2), \$25 ea pls shpg; Lambda LX5-A-5-OV 5 volt 4 amp pwr supply, \$15 pls UPS. G Kirby, Marysville Bacs, 13613 US 36, Marysville OH 43040. 614-261-8871.

Various pieces of equip including (5) Scully 270's; Sparta AS-30's; Ampex, Harris, Studer, Shiveley, etc pieces also, too numerous to list, write for more info & prices. P Moore, KXFX, 1410 Neotomas Avenue, Santa Rosa CA 95405.

Giant Boom Box covers for the giant boom box manufactured by Rainbow Enterprises, \$1500/BO plus shpg. Tony, WNOK/WOIC, 803-771-0105.

Low power TV license, VHF-8 in south central Missouri town, growing area, some financing avail. 417-967-2242 or 417-932-4098.

Dale Power Arrestor SPA 200 (2), new & never installed, BO. C Phillips, PO Box 987, Clinton TN 37717. 615-457-2697.

Western Electric T, R, S patch panels, wire wrap or solder connections, Weco 94 N repeat coils & new KS20159 line EQ, BO. R Kerbawby, Box 1127, Beckley WV 25802. 304-877-5592.

Gentner teleprocessor-telephone audio processor (2), \$200/ea. R Meadows, 1203 Seaton Rd #117, Durham NC, 27713. 919-544-1366.

Telex CD2MS w/CD2S and 3 +1 duplicator, \$1700. R Meadows, 1203 Seaton Rd #117, Durham NC 27713. 919-544-1366.

Spectra Pro II light meter for film or still photography, exc cond w/manual, \$100. D Lasko, 3054 Gold Canal Ste D, Rancho Cordova CA 95670. 916-638-7770.

Office telephone systems, small key systems to large PBX, several sizes, working well. J Callaghan, Baron Aviation, 1601 N Marginal Rd, Cleveland OH 44114. 216-574-2525.

Belden cable various lengths and types, priced below wholesale. R Kerbawby, Box 1127, Beckley WV 25802. 304-877-5592.

Small xformers HI to LoZ already mounted if needed; manuals, Ampex, Pultec, Altec others, send for lists. Mr Oliver, 212-874-7660 in afternoons.

Altec 1567 Hi-LoZ mixer, w/xformers, VU meter & more. Gramplan circuit heads ID feedback; lead screws for 6N presto cutter; Daven attenuator ladders 1020 600-600 patch bays single inputs/patch cords; Sencore transistor tester; other items. Mr Oliver, 212-874-7660 in afternoons.

Want to Buy

Transcriptions, RCA Thesaurus & Associated, B Davies, Virgo Prod, 5548 Elmer, N Hollywood CA 91601. 818-761-9831.

WWII vintage radar equipment units & complete systems. A Weiner, Britton Rd, Monticello ME 04760. 207-538-9538.

Pre 1960 bdct equip, magazines, catalogs, instruction manuals, 7" & 10" blank recording discs, On-Air lights, RCA & WE audio equip, 16" transcriptions, R Van Dyke, Caffrey House, Squires Ave, E Quogue NY 11942. 516-728-1327.

CONSULTANTS

RF and Audio Coast to Coast
STEVE VANNI ASSOCIATES, INC.
BROADCAST TECHNICAL CONSULTANTS

Project Management
Facility Planning

P.O. Box 422 Auburn, NH 03032
(603)483-5365

EVANS ASSOCIATES
Consulting Communications Engineers

FCC Applications, Design
& Field Engineering
Broadcast Engineering Software

216 N. Green Bay Rd.
Thiensville, WI 53092

(414) 242-6000
Member AFCCCE

W. LEE SIMMONS
& ASSOC., INC.

BROADCAST
TELECOMMUNICATIONS
CONSULTANTS

1036 William Hilton Pkwy
Ste 200F
Hilton Head Is., SC 29928

(803) 785-4445

Consulting Communications
Engineers

- FCC Data Bases
FCC Applications and Field
Engineering
Frequency Searches and
Coordination
AM-FM-CATV-ITFS-LPTV

OWL ENGINEERING, INC.

1306 W. County Road. F,
St. Paul, MN 55112
(612)631-1338 Member AFCCCE

SOFTWARE
FM CHANNEL SEARCH

FM Database pool

MSDOS
EGA Graphics-Color
Broadcast Technical
Consulting

Doug Vernier
Broadcast Consultant
1600 Picturesque Drive
Cedar Falls, IA 50613
319-266-7435

MAGRILL ENGINEERING
Radio Engineering Consultants

FCC Applications - Upgrades
Pre-purchase evaluations
Station planning & Design
Turnkey systems - Field service

Experienced, Economical & Fast
(904) 591-3005

Barry Magrill P.O. Box 1010
President Fairfield, FL
Member IEEE 32634

MEHALKO
COMMUNICATIONS CONSULTANTS

BUY & SELL
AUDIO & VIDEO EQUIPMENT

3 Hurd Street
Mine Hill
New Jersey
07801
MCC

1 (201) 361-1917 Mike Mehalko

new station field service
construction AM directionals

RON KROB
broadcast technical consultant

4910 Four Star Court
Fort Collins, CO
80524 303 484 2704

Moffet,
Larson &
Johnson, Inc.
Consulting Telecommunications
Engineers

Two Skyline Place
5203 Leesburg Pike # 800
Falls Church VA 22041
703-824-5660
800-523-3117
Member AFCCCE

DISPLAY YOUR CONSULTANT'S CARD HERE
AND BE SEEN BY OVER 21,000 READERS
Call Simone Leaser at 800-336-3045

SERVICES

RADIO SYSTEMS
ENGINEERING

FCC Applications • Design
• Installation • Field Service

Experienced & Affordable

4289 Roanridge
Las Vegas, Nevada 89120

24 Hr: (702) 454-2085

HARMON'S TOWER
SERVICE, INC.

Maintenance, Painting,
Antenna & Equipment
Installation,
Winch Services

435 B Broadway
Columbus, GA. 31901
(404) 327-1074

SPENCER
BROADCAST

The Radio Station
Specialists

Chuck Spencer
Phoenix, AZ
602-242-2211

ENGINEERING SERVICES

REGISTERED PROFESSIONAL
ENGINEERING STAFF

• STRUCTURAL • CIVIL • MECHANICAL •
Tower and Antenna Support Systems Analysis,
Inspection, Modification, and Appraisals.

division of
CENTRAL TOWER INC.
P.O. Box 530, Newburgh, IN. 47630
Phone: 812-853-0595

DOWNEAST
ENGINEERING

147 Durham Rd., Freeport, ME 04032
(207) 865-9002

Electronic Repairs & Services
Equipment Piled Up In Need of Repairs?
(Qualified Service Technicians)
New & Used Equipment (Call for
Price) New Studio Designs
BROADCAST SPECIALISTS
WILLIAM H. YANIK
(Manager, Sales and Service)

TOWER SERVICES

Light Replacement
Routine Maintenance
Ground Systems
Painting
20 years Experience

John Nix
PO Box 13244 Salem, OR 97309
503-581-4056
1-800-321-4056

SPECIALIZING IN ERECTION,
REPAIRING, PAINTING
AND MAINTENANCE
RADIO, TWO-WAY, TV, TOWERS
AND FLAG POLES

A STEEPLEJACK CO.
PAINTING AND STEEPLEJACK
CONTRACTORS

FULLY INSURED FOR YOUR PROTECTION
DON HIGHLEY 3722 ROMA
713-462-6105 HOUSTON, TEXAS 77080

MIRKWOOD
ENGINEERING

Rural & Remote Site
Field Engineering

50 Park Ave.
Claremont, NH 03743

603/542-6784

PARAMOUNT
COMMUNICATION SYSTEMS
INSTALLATION AND SERVICE OF BROADCAST
ANTENNA SYSTEMS/TOWER MAINTENANCE & ERECTION
WESTMONT, NJ (609) 869-0222

THIS SPACE AVAILABLE
Call 1-800-336-3045

MONITORS

Want to Sell

Nems-Clarke 8 tower phase monitor, \$300.
F Vobbe, Great Northern Bdct Co, POB 5031,
Lima OH 45802. FidoNet 1:234/16.

McMartin TBM3500 & TBM 2200A FM mod
monitor & stereo mod monitor, \$500/pr. L. Col-
lins, Collins Assoc., POB 422, Washington NH
03280. 603-495-3983.

Gulf & Western 1000 Sensaphone w/three
alarm inputs, direct modular connection to
phone line, \$75. R Hardy, 3239 S 90th East
Avenue, Tulsa OK 74145-1661. 918-627-2937.

McMartin 3500B, 2200A, RFM-1 Full Stereo
Package, \$2000/BO, J Phillips., WZOM-FM,
4081/2 Clinton, Defiance OH, 43512, 419-782-
8591.

Belar AMM2 AM mod mon, excel cond, \$580.
M Brown, KKGK, 503-245-4889.

TFT 760 EBS unit for parts, the pwr supply,
encoder, AM/FM rcvr are fine, decoder not
working, \$150/BO. L Albert, WKMS, POB
2266, Murray KY 42071. 502-762-4664.

RCA WM-43A cond unknown, BO D Niccum,
KOZA, 1301 S Crane, Odessa TX 79760. 915-
333-3101.

Want to Buy

Potomac AM 19(204) antenna monitor for 4
tower array needed ASAP. G Sies, WRYT, 9
Cougar, Edwardsville IL 62025. 618-692-9798.

Belar FMM1, FMSI, SCAL, RFAI, gd cond. J
Phillips, WZOM, 409-1/2 Clinton, Defiance OH
43512. 419-784-1059.

Belar or TFT FM mod monitor, stereo, prefer-
ably w/freq monitor, also need crystal 96.3;
Wegener SMN receiver frame w/format cards
for sat mys network, splitter 1601. LJ
Maierhofer, WTGC, 101 Armory, Lewisburg PA
17837. 717-523-3271.

FM monitor for EDFM, gd cond, inexpensive
or will help w/appraisal for taxes. J Goggan,
MO River Christian Bdct, POB 87, Washing-
ton MO 63090. 314-239-0400.

MOVIE PROD EQUIP

Want to Sell

Kodak Pageant Marc-300 high intensity,
16mm, sound movie projector w/pwr supply,
near mint cond, \$598. G Ormrod, 432 East
X Street, Tumwater WA 98501. 206-352-8028.

New Eiki SL-0 16mm slot load projector, \$450;
Maurer 05 body, 4 mags, no motor, \$750; new
Bell & Howell 70 DR w/Anvil case, 1" Comat,
instructions, \$325. J Kreines, DeMott/Kreines
Films, 5330 Kennedy, Millbrook AL 36054.
205-285-6179.

Elmo/Honeywell 16-SS 16mm w/sound proj.
auto thread, auto lub, solid state audio, lamp
saver, spare lamps, wide-angle lens, like new.
\$250/BO. R Dunn, 712 Colorado, Modesto CA
95351. 209-529-9967.

Want to Buy

Mitchell 35 & 16mm cameras & access; oth-
er professional 16/35mm cameras; Upright
Moviolas, especially 35mm; Westrex 35mm
optical recorders; Zeiss 9.5mm Distagon,
reasonable, need not be mechanically mint.
J Kreines, DeMott/Kreines Films, 5330 Kenne-
dy, Millbrook AL 36054. 205-285-6179.

RECEIVERS & TRANSCEIVERS

Want to Sell

Scientific Atlanta 7300/7325 digital satellite
rcvr, 15 kHz, 1-7.5 kHz, voice cue card, (3)
crystals, like new, \$9000; HD955 delay, mo-
no, 6.4 seconds, 15 kHz, \$1750; ABC Talk Ra-
dio cue demod, McCurdy MRP-1, w/interface
& printer cables, \$500. J Katz, Westcoast
Bdctg, 209-686-2866.

Johnson Electronics ST-4A subcarrier
receivers, converted for 4800 baud data
reception, 92 & 87 kHz. D Leinen, Indepen-
dent Resources, POB 23498, Oklahoma City
OK 73123. 405-721-1187.

Aerotron PAC II 6 chnl 5 W VHF hand-held
(4) w/wall charger & extra battery pack for ea
PL encode, one unit w/DTMF, leather case,
\$75 ea; Motorola TAE 6010A coaxial antenna
for 450-470 MHz, can be used mobile or fixed
(2), new, \$15 ea. P Russell, Bowdoin College,
Brunswick ME 04011. 207-725-3066.

Marti RR50/450 RPU late mdl UHF rcvrs, excel
cond, \$600 ea; Marti MR-100 (2) UHF RPU
rcvrs, excel cond, \$200 ea or \$375/both. R
Wright, WLLX, 1208 N Locust, Lawrenceburg
TN 38464. 615-762-6200.

Marti RR50/450-2 remote pickup rcvr tuned
to 455800 & 455850, excellent condition, low
hrs, \$600. R Hardy, 3239 S 90th East Avenue,
Tulsa OK 74145-1661. 918-627-2937.

GE Exec II & MVP 100 watt, single channel
channel guard, 42-50 MHz, \$75; MVP on
52.525 MHz, 20 watts, \$125. P Russell, Sills
Hall, Brunswick ME 04011. 207-725-3066.

WE'VE DONE THE HARD PART

Our new program computes TV
& FM Field Strength for you. It
uses the FCC algorithm to deter-
mine distance to contour, field
strength at distance, and bear-
ings between coordinate pairs. It
runs on any IBM-PC compatible
and incorporates FCC Docket 88-
56 rules. Only \$95.00

Jeremy Lansman
Spectrum Resources
POB 240-467
Anchorage AK 99524
(907) 345-2630

GE PY (8) VHF, 1 channel, 5 watt handhelds
w/PL encode, (1) 5 unit rack charger, (5) rap-
id charge single charger, \$75 ea. P Russell,
Sills Hall, Brunswick ME 04011. 207-725-3066.

Want to Buy

Motorola 2-ways, 2m or 10m ham rig. J
Schloss, KICD, 2600 Hiway Blvd, Spencer IA
51301. 712-262-1240.

KLH 21 FM table radio, will buy or swap oth-
er equip. J Roper, Imperial Snd, RFR 31 Box
405, Terre Haute IN 47803. 812-877-2663.

Scientific Atlanta digital satellite rcvr, DPU
w/pwr supply & DMX plus cable to receiver,
DAT 32. D Roper or M Tinsley, 804-847-1266.

Satellite rcvr set for Satcom 1-R-21. J Cor-
coran, 509-662-7135.

Scientific Atlanta or Fairchild looking for rec.
pkge. for ABC Radio Net., contact R Hall or
A Reis, SMN Chicago, 708-479-1717.

REMOTE & MICROWAVE EQUIP

Want to Sell

Moseley 606/C tuned 947.500 MHz, \$7500.
T Langham, TL Engr, 1508 S Owasso, Tulsa
OK 74120. 918-587-0941.

Fairchild Dart 384 15 kHz dual audio card
in gd working order, have two only one, \$750.
RL Wood, KOWO, 222 N State, Waseca MN
56093. 507-835-5555.

1987 custom built remote studio trailer, 8x20,
(3) rooms, generator, kitchen, dual AC & heat,
(2) PA systems, custom paint & detailing, call
for info, BO, J Rabell. 619-278-1130.

Moseley MRC-1600, excel cond, 2 yrs old,
\$3500/BO. B Simmons, KGRV, POB 1598,
Winston OR 97496. 503-679-8185.

Moseley SCG-8 92 kHz subcarrier gen, 6
mos old, \$850, or gd cond ITC-750 deck as
part. K Brouall, KTRZ, Box 808, Riverton WY
82501. 307-856-2922.

Moseley TRL-1 xmtr & rcvr w/manuals, com-
plete system, \$2000. B Slowikowski, WQCB,
49 Acme, Brewer ME 04412. 207-989-5631.

Fairchild Dart 384 75 kHz dual program card,
excel cond, \$600/BO. D Kelley, KISZ, POB
740, Cortez CO 81321. 303-565-1212.

WANT TO BUY
STL's & STL Antennas
ARMSTRONG TRANSMITTER CORP.
5046 Smoral Road (315) 488-1269
Syracuse, NY FAX (315) 488-1365

Microdyne 1100 PCDR-5 SCPC demodula-
tor, excel cond, 3 yrs old, \$1400. J Shea,
WHUC, Union Tpk, Hudson NY 12534. 518-
828-3341.

Gentner VRC-2000, \$3000 cash. W Cox,
WCGA, Rt 9 Box 240E, St Simons GA 31522.
912-638-1100.

Fairchild/Comtech Dart-384, complete digi-
tal sat rcvr, sold as complete system or
separately, BO. W Fanning, August Studios,
1428 Marcheck, Jacksonville FL 32211. 904-
743-7131.

Moseley TRC-15 remote control, fixable,
\$400/BO. M Brown, 503-245-4889.

Stationmaster PD-455 RPU 450 MHz, ver-
tical, new, \$450 or BO. D Eressy, 509-945-
4855 am.

Marti RPT2 & RPT25 2.5W & 25W xmtrs,
450.100 MHz never used; Marti CR-10 RPU
rcvr, 450.100 MHz never used, B/O. D Eressy,
508-945-4855 am.

Comrex PTLX 2-line, like new, \$3500. D Rose-
ma, Impact Radio, 512-837-7725.

TFT 7610, 3 yrs old, last calibrated 5/88, no
manual, perfect cond, \$1500/BO. Vince, 2977
Doughill, Irving KY 40386. 606-723-2200.

TFT 7610-C perfect shape, manual included,
\$1500/BO. V Richardson, 1024 College, Jack-
son KY 41339. 606-666-4946.

Comrex LXT & PLX low freq extenders (10).
R Meadows, 1203 Seaton Rd #117, Durham
NC, 27713. 919-544-1366.

QEI 811 SCA on 67 kHz, excel cond w/manu-
al, \$475. V Clough, 225 Green St, Fayetteville
NC 28302. 919-486-4991.

Moseley SCG-8 92kHz subcarrier gen, 6
months old. K Brouall, Box 808, Riverton WY
82501. 307-856-2922.

Moseley SCG-8 & SCD-8 both like new cond,
\$1500/both. D Jack, Mtn. Media. 208-286-
7876.

M/A com 23 GHz Microwave radio system,
Hughes STX 141 xmtr, Scientific Atlanta
8350 agc mlr, mon, Lenco distribution amp,
Ward Beck distribution amp, Videotek RF
demodulator, sell as pkg or BO/unit. T Pelis-
sero, 612-378-1254.

Moseley PCL505 (2), complete STL systems,
presently in use, BO. G Myrick, Box 845,
Spearfish SD 57783. 605-642-7792.

Comrex Freq Extenders LXT's, PLX's, LX-
PC's, TLX (25+), sell individually or as group,
excel cond. R Meadows, Southeastern Sports,
1203 Seaton Rd #117, Durham NC 27713. 919-
554-1366.

Moseley PCL303 tuned to 949.000, xmtr &
rcvr in excel cond, currently in use, \$2500. J
McBride, Box 464, Osceola IA 50213. 515-342-
6536.

Gentner Teleprocessor telephone audio
processor, \$200. R Meadows, Southeastern
Sports, 1203 Seaton Rd #117, Durham NC
27713. 919-554-1366.

Want to Buy

Harris Sentinel 16 needed ASAP. G Sies,
WRYT, 9 Cougar, Edwardsville IL 62025. 618-
692-9798.

Moseley PCL-505 STL. W Axell, KSAY, POB
2269, Ft Bragg CA 95437. 707-964-5729.

Moseley PCL606-C composite STL, excel
cond, \$5900. C Knerr, KCNA, 139 SE J St,
Grants Pass OR 97526. 503-474-7564.

Marti RPT-15 or RPT-30 for sports bdcts. UHF.
P Baillon, 612-222-5555.

DDual audio channel program module, 75
kHz for a Fairchild Dart 384. J Cole, WBTM,
710 Grove St, Danville VA 24543. 804-793-
4411.

SA or Fairchild digital rcvr & 3.8 m dish for
ABC Radio network, must be in gd cond. L
Dupree, KQID, 1115 Texas Ave, Alexandria LA
71301. 318-445-1234.

TSL System, prefer Moseley, TFT or Marti.
D Kelley, KISZ, POB 740, Correz CO 81321.
303-565-1212.

TFT 7701 STL rcvr, will consider other mdl's
of composite STL rcvr using 75 microsecond
de-emphasis. M Blumstrom, KUNR, Reno NV
89557. 702-784-6083.

Contact Radio World Newspaper for availabilities.

P.O. Box 1214 • Falls Church VA • 22041

EMPLOYMENT

To place ads in this section, use the ActionGram form. To respond to box numbers, write Radio World, PO Box 1214, Falls Church, VA 22041, Attn: _____

WANTED

BROADCAST AUDIO EQUIPMENT SALES REPRESENTATIVE

We need an aggressive individual to join a growing, industry leading audio equipment manufacturing company. If you have 5 yrs or more experience in selling radio or tv equipment to distributors and end users, we'd like to talk to you about this once in a lifetime opportunity.

Position requires as much as 50% travel. Compensation is commensurate with experience and includes an excellent benefits package.

Send your resume and salary history to . . .

Radio World, PO Box 1214,
Falls Church, VA 22041
Box 90-02-01RW.

HELP WANTED

Assistant Engineer needed for the WMC Radio stations. 300 kW FM 5 kW directional AM. A.S./Electronics or equivalent exper. Strong interpersonal, maintenance & troubleshooting skills. Broadcast exper a plus. Tom Nichols, WMC, 1960 Union Ave, Memphis TN 38104. EOE.

**BOSTON'S
WZOU-94.3**

Aggressive top-rated CHR searching for state of the art chief engineer. Must have knowledge concerning multi-track facility and studio installation and a keen ear for 90s CHR audio processing. If you're not afraid to tackle exciting projects, rush resume and background material to:

**Alan Chartrand, G. M.
WZOU-FM
313 Congress Street
Boston, MA. 02210**
Ardrman Broadcasting of MA.
EOE/MF

POSITIONS WANTED

Innovative veteran NYC talk-radio producer seeking greener pastures in Top 12 markets: Radio/TV. J Segal, 212-966-0186.

Newcomer wanting entry level radio, 10 mos station work in tech, traffic & mgmt, will start from bottom. D Rayner, 503 Sunnyside, Aurora IN 47001. 812-926-2013.

Personality desires fun, promotionally active situation w/creative freedom, AM or FM, night or day shift. Eleven year pro, in AZ now. Call Mike, 602-721-7263.

Sharp, young, aggressive audio sales pro seeks position as marketing mgr for respected, stable pro audio mfr. Bill, 415-726-4786.

Wish to relocate to Charlotte NC, 13 yrs in radio, air, production, traffic, detail-oriented pro. on- or off-air position considered. Jim, 813-461-3192.

Experienced, 8 yr veteran in programming, on air & some engineering exper. Currently working top ten market. Dade Moore, 713-441-8193.

Engineer, 20 yrs exper including AM directional, high power FM, station construction, seeks position in Northeast or Upper Midwest, but all locations considered. Reply to: Radio World, POB 1214, Falls Church VA 22041. ATTN: Box 89-10-01RW.

Electronic comm eng w/11 yrs exper, fluent in French/German, FCC license, computer skills avail, overseas preferred, will relocate. C Martin, POB 9781, Bowling Green KY 42103.

TV/Radio throbred, dynamic, intelligent, creative, charismatic GM, earned mgmt from talent/sales successes, incredible motivator, team player, can & will do it all. A Stephens, 8101 S US Hwy One Ste 7C, Jupiter FL 33477. 407-743-1456.

Eng/announcer, w/over 18 yrs in radio, 13 yrs as chief & PT adv salesman, seeking gd FT position, dedicated & team player, FCC, SBE, NARTE, desire SE US, East or West Coasts. E Garrett, 5857 Sheldon Ct C, College Park GA 30349. 404-766-0742/2577.

Broadcast eng w/13 yrs exper as CE & consultant, excel track record of tech achievements & effective teamwork. Write: Radio World, POB 1214, Falls Church VA 22041. Attn: Box 89-11-01RW.

Quality entertainer w/33 yrs exper, marketable, specialize in Big Bands, oldies, 7-midnight or all night. J English, 2450 Pine Island, Matlacha FL 33909. 813-283-3910.

Announcer/Engineer, Bdctg degree, over a yrs exper at Chicago station. Would like to relocate South or Southwest US, any size market. Mike, 312-636-0119.

Quality entertainer, 33 yrs exper, marketable, specialize in Oldies & Big Bands, 7-Midnight/all night. J English, POB 10, Matlacha FL 33904. 813-283-3910.

Exper announcer w/winning attitude avail for medium or large market CHR or AC, overnights OK in Midwest or South. Patrick, 217-789-9806.

SALES MANAGER EQUIPMENT MFR.

Top money for the aggressive manager. Pack your bags and go to work for this major Radio Broadcast Equipment Manufacturer. Northeast location, but expect to spend much of your time at regional, national, and international trade shows and seminars. Responsibilities include dealer selection, training, and management, seminar and trade show coordination, and new product introductions. Requires a background in broadcasting and good technical knowledge.

Reply to: Radio World
POB 1214
Falls Church VA 22041
Attn: Box SD

Five plus yrs exper, reliable, dependable, hard-working seeks on air spot in South Dakota & surroundings states. B Csongradi, 605-882-3239. leave message.

On-Air 5 yrs plus, PD, ND, MD, dependable, hardworking seeks on-air in SD, ND, MN, write: BC, 225 4th St SW, Watertown SD 57201.

Experienced on-air/programming, (8 yrs) w/some engineering seeking position, currently working in top ten market. Dade, 713-441-8193.

College Grad, 4 yrs exper, veteran, highly praised metal show, gig wanted in CT crazy, dynamic pro, top blade skills. M Dodge, 203-787-9277 or 787-1006.

Video/Film director of photography w/wide variety of exper seeking position w/Los Angeles area production house. Brooks Institute graduate. Roland Nesbit, 3005 Rhodelia, Claremont CA 91711. 714-625-6919.

Creative force/afternoon drive/PD, 100% increase last Birch, at #60 market small station, seeks creative/programming/promotions position in Raleigh/Greensboro markets. 919-929-3947.

On-air, MD, ND, PD w/5 yrs exper seeks on-air in South Dakota/surrounding states, avail now, leave message, B Csongrad 605-882-3239.

Technical writer on contract basis, exper in audio, RF & publ writing, SBE-certified as Sr AM/FM bdct eng. T McCartney, 1075 Washington Ave SE Ste 17, Bemidji MN 56601. 218-751-1680.

GM Radio vet 17 yrs, seeking position. J Walsh, 1124 West Hartlage, Corydon IN 47112. 812-738-8843.

Will Relocate over 7 yrs. exp. in news, spits., prod., and on-air. Resume c request. T Lalii, 533 South 2nd Apt B, McAlester OK 74501.

Husband & wife team sales, air personalities, engineer, 18 years, urban/oldies/gospel, 2 persons, one salary, one year contracts (V1, Bermuda, Bahamas or US) Chuck, 904-351-8155.

Seeking FT announcing position, would like to relocate to St. Louis MO, 4 yrs exp in college & Christian radio. Eric, 404-924-7780.

Community oriented 8 yr CWAC/AOR pro seeks sm mkt PD/OM position to call home, currently employed w/exc refs. J Lundy, 517-773-7811.

Amicable, accomplished marketing/PR pro desires opportunity to utilize/expand creative abilities to profit broadcast network, station or progressive production firm. B Honeker, 303-233-7274.

Announcer/PD w/leadership skills & degree seeks small/medium oldies/AC/news AM/FM, prefer Florida or Atlantic/Gulf Coast. Todd, 919-455-2202/6000, FAX 919-455-7139.

REMOTE & MICRO . . . WTB

Satellite reception system for Transtar's Niche 29. R Schlosser, WSTV, 320 Market St, Steubenville OH 43952. 614-283-4197.

950 MHz discrete STL recvr's (2), rcvrs only. E Allen, 615-894-1023. FAX 615-875-3306.

RPU xmtr 450 MHz band. R Castro, 6640 Redwood Drive #202, Rohnert Park CA 94928. 707-584-1058.

Comrex LX-T & LX-R freq extender chain, will consider earlier PLX & RLX mdls; any or all parts of chain. Motor Sports Radio, 1285 Zevan, Johnson City NY 13790. 800-462-5677.

Gentner SPH-3 telephone interface & Microtel w/AC transformer. Motor Sports Radio, 1285 Zevan, Johnson City NY 13790. 800-462-5677.

STATIONS

Want to Sell

FM in Southwest Texas, all new equip w/bldg & land, will sell part to investor. A Moll, KLXQ, 128 Memory Trail, San Antonio TX 78232. 512-496-0677.

FM Class A single market in SW OK needs owner-operator, responsible party take over payments of \$1426/mo at 9% interest, upgrade possible. BO. R Kerr, KRMK, One Confederate Rd, Altus OK 73521. 405-482-3966.

SF Bay area bdct school & cable FM network, 10 yrs old, profitable, expansion potential in top affluent market, modern studios/offices, Dept of Ed approved, \$375K. J Bryan, KCRK, 1656 N California, Walnut Creek CA 94596. 415-935-5100.

Fully equipped Mississippi AM in a single station market. Std/xmtr/tower on single site renting for \$250/mo. Continuous operation for 20 yrs, currently losing less than \$1000/mo, absentee owner has other interests. J Clinton, 601-268-7892.

Class A stereo FM radio station, Mississippi, cash or terms. G Shurden, 601-843-4091.

CP for FT AM great dial position, populated area, 10-kw non-dir. days; 500-w-N, DA. Can move within 5-miles of Nashville and increase to 50-kw days. P Severy, P.O. Box 40333; Nashville TN 37204. 615-832-4653.

AM radio station, 1000 W in Albertville AL, possible increase of power to 2500 W, must sell due to illness of owner. Patsy King, Rt 6 Box 1245, Albertville AL 35950. 205-586-4160/5197.

Equity interest available in AM in dynamic Four Corners area of S.E. Utah, principals only, only station in county, Inquiries confidential. P Mueller, Hiway 191 N (6-1), Blanding UT 84511. 801-678-2261.

AM CP in dynamic resort area 5kW of pwr on gd freq, J Evans, Rt. 4 Box 242, Knights Academy Rd, Valdosta GA 31602. 912-247-6859.

Want to Buy

Looking for FM or AM/FM in Northwest Ohio, Southeast Michigan, confidential serious replies only. F Vobbe, Great Northern Bdct Co, POB 5031, Lima OH 45802. FidoNet 1:234/16.

AM/FM stations or CPs including dark stations, bankruptcy situations, assumption of debt situations. Doc Pollock, First Bdct Corp, POB 691, Wilmette IL 60091. 312-902-4410.

AM stations high power turnarounds at good price, top 150 markets, daytime & dark stations OK, include price/terms & city, grade coverage map. Mr. Stevens, PO Box 732, Langley SC 29834. 803-593-5000.

Looking to purchase AM daytime in St. Louis, seeking investors for project. For business plan, write: Eric Bueneman, White Birch Comm., 5002 Cross Ridge Ct., Woodstock GA 30188-4380.

STEREO GENERATORS

Want to Sell

Motorola 1300/1310 C-Quam stereo system, 1360 kHz, CRL SPP 800, (2) SEP 400, SMP-900, all gd cond, BO/whole package. J Davis, WCHL, POB 2127, Chapel Hill NC 27514. 919-942-8765.

Gates 6095-6146 exciter/stereo gen in 4' rack, includes stereo Audimax processor, metering, on-off controls, manuals; complete working 10 W stereo xmtr, \$700/BO pls shpg. M Meyer. 313-686-0447.

Harris TE-3 exciter, (2) stereo gen, (2) SCA gen 67 kHz, BQ. C Benner, WUSL, 440 Domino, Phila PA 19128. 215-483-8900.

Modulation Sciences DSCA-188 data Sidekick SCA gen, 92 & 62 kHz. D Leinen, Independent Resources, POB 23498, Oklahoma City OK 73123. 405-721-1187.

CRL SC-800 slightly used, \$650/BO. R Bendheim, PO Box 135, Redway CA 95560. 707-923-2513.

Harris MS-15R w/manuals, BO. R Hays, KYKK, 619 N Turner, Hobbs NM 88240. 505-397-4969.

Harris SCA module, 67 kc for MS15 & MX15 exciter, working, \$200; extender board for MS15 & MX15 exciter, \$35 pls shpg. E Davison, Multiplex, 135 N Illinois, Springfield IL 62702. 217-787-0800.

SWITCHERS (VIDEO)

Want to Sell

Echo II SE6 switchers (2) w/RCA TG-3 sync/pulse pattern gen w/racks, \$1400, may sell separately. R Lawrence, Moonshadow Video, 4280 Reston Rd, Roseburg OR 97470. 503-679-8966.

Sono-Mag DS20A 6 yrs. old, gd. cond. \$500. B Weeks, P.O. Box 107, B Falls VT, 05101. 802-722-4890.

Cross Point Latch 6112 w/8 inputs 2ME5 enclosed chromo key, downstream keyer, \$2500. H Larson, Matrix TV, POB 536, San Luis Obispo CA 93406. 805-544-5657.

Crosspoint Latch 6119 special effects gen/switcher, \$1500 plus shpg. M Holdwin, Anamnesia Studios, 40 South Oxford Street, Brooklyn NY 11217. 718-852-7630.

Want to Buy

DP-1 w/AS switcher. L Nelson, WSPY. 708-552-8985.

TAPES, CARTS & REELS

Want to Sell

Approx 300, 105' reels of tape w/AOR music on them, 50¢ per reel plus shpg. S Beeny, KRMS, POB 225, Osage Beach MO 65065. 314-348-2772.

Over 3000 45's & LP's, all spanish in top cond, will record for automation if needed. A Moll, KLXQ, 128 Memory Trail, San Antonio TX 78232. 512-496-0677.

A&D

Cartridge Rebuilding Service

We clean, load & pack. Serviced within 10 work days! Work guaranteed!
3380 Blakely Ave., Eau Claire, WI 54701
(715) 835-7347

Complete 78 rpm library, not picked over, as it was left 30 yrs ago over 1,260 records & ASCAP/BMI books from 1949-1972, many famous names & songs, must buy entire collection. BO. G Johnson, WAGN, 413 10th, Menominee MI 49858. 906-863-5551.

20 year collection of 600 plus R-R tapes containing jingles, airchecks, various prod, music tracks, etc. Will sell w/dbx & Dolby NR equip. BO. Send SASE for specific info. F Vobbe, Great Northern Bdct Co, POB 5031, Lima OH 45802. FidoNet 1:234/16.

Ampex tape, (300) 10" reels, bulk-erased, including reels, \$5 ea. T Moore, WBCO. 419-468-2326.

Reels, (1000) 5" w/NAB hubs. BO. S Voros, 1537 S 81st, Milwaukee WI 53214. 414-475-6200.

Sound Ideas sound effects library on 1/4" reels, over 3000 effects, excel cond, including catalog, \$650/BO. T Keenan, Creative Media, 11105 Knott, Cypress CA 90630. 714-892-9469.

Various reels of tapes, 5', 7', 10', OK for background, non-essential use. BO. A Allegra, 1380 Valley Forge, Lansdale PA 19446. 215-368-4444.

Scotch & Sony U-Matic UCA & KCA cassettes in boxes, excel cond, mostly 30's, some 40's & 60's, (58), \$290. A Allegra, 1380 Valley Forge, Lansdale PA 19446. 215-368-4444.

Fidelipac Cobalt 100 carts, 50 ea, 40 and 70 sec. New, sold as unit only. \$425 firm. A or S Reis, 308 Eastgate Court, New Lenox IL 60451. 815-485-7388.

London Music Library 78 RPM, circa 1950. D Eressy. 509-945-4855 am.

Fidelipac Mastercarts (approx 700) w/MOR music, 2.5-3.5' lengths, gd cond, \$2 ea. J David, KMPL, POB 907, Sikeston MO 63801. 314-471-1520.

IGM big band type music on 10" reels, \$20 and 14" reels, \$30, some never played. F Anderson, 3801 5 Ave South, Great Falls MT 59405.

Audiopak AA-3, AA-2 (150) assorted lengths, all reloaded w/new high output tape, new pads, excel cond, BO. R Kaufman, PAMS Prod, POB 462247, Garland TX 75046. 214-271-7625. Aft 2PM CST.

Audiopak carts AA4-SGS-4, length of carts: 46-75, 41-85, 51-55, 14-105 (152), \$3/ea. M Anthony, 4305 Industrial Rd #120, Las Vegas NV 89103. 702-739-9600.

Scotchcart II AA-40 (10), never used, \$25. R Meadows, Southeastern Sports, 1203 Seaton Rd #117, Durham NC 27713. 919-544-1366.

Scotch & Sony U-Matic low use cassettes, some 60's, 40's & 30's, (58), exc cond, \$5/ea. A Allegra, 1380 Valley Forge, Lansdale PA 19446. 215-368-4444.

Ampex 30 & 60 min blank cassettes, (300) 30's, (300) 60's, (600) soft cassette boxes, tapes are master quality, \$300. R Meadows, 1203 Seaton Rd #117, Durham NC 27713. 919-544-1366.

Audio tapes approx 175, 10 1/2" reels of audio tape, boxes included, 1-mil thickness, you pay shipping, \$4 per reel/BO. T Murray, 100 W 9th Street #306, Rochester IN 46975. 219-223-6059.

Want to Buy

Used tapes & reels for automation, 10" reels. A Moll, KLXQ, 128 Memory Trail, San Antonio TX 78232. 512-496-0677.

Thesaurus, standard, Capitol ET's or gd 14" dubs, also catalogs, call collect. C Hunt, Voices, POB 153, LaGrange IL 60525. 708-579-9578.

New, boxed, unused Seeburg/Rowe 16 rpm background music records, any quantity, write price; also jazz/swing 78 rpm libraries or collections wanted. F Luppino Jr, Mktg Insights, 1445 Sunset Ridge, Glenview IL 60025. 312-729-2047.

Tape reel hold downs for Ampex 300,301,302,354,AG440 MR 70 ETC; pwr cords for Ampex 301, 354 & AG 440. Mainline Comm, 100 Poplar Street Portage PA 15946. 814-736-3883.

TAX DEDUCT EQUIP

Group home working w/troubled teenagers seeking donated video & audio or related equip for tax purposes. R Scott, ISOT Inc, Box 35, Canby CA 96015. 916-233-4106 or 233-5151.

Radio reading service for the blind & print-handicapped in CT looking for donation of 2 cart machines for Fairfield county satellite studio, will pay for shipping or pick-up. Cynthia Clark, CRIS Radio, 589 Jordan Ln, Wethersfield CT 06109. 203-246-3579.

HF/VHF/UHF amateur and/or commercial comm equip in working or repairable cond, transceivers or handhels, packet TNC & PC equip; 12V battery back-up, will pay shipping or pick-up; CB equip also. J Bondon, 7101 W 80th, Los Angeles CA 90045. 213-642-3698.

Used radio equip for donation to college station. P Hess, WPPJ, 201 Wood. Pgh PA 15222. 412-392-4725.

Electronics eng student seeks donation or old but repairable, studio or xmtr equip. RS Lynn, Rt 1 Box 152-D, Loudon TN 37774.

Missouri River Christian Bdctg seeks 1 kW FM xmtr, exciter, stereo gen, FM monitor, cart machine. Will help w/appraisal for taxes. J Goggan, KGNV, POB 87, Washington MO 314-239-0400.

El Salvador Christian station needs (2) 8008 pull-outs & usable 892Rs, we pay freight. J Counter, YSLE, 5484 San Patricia, Santa Barbara CA 93111. 805-967-6100.

Christian Ministry needs donations for low power, 250 W, FM station: FM mod mon; FM AGC processor limiter; hi-gain antenna on ED band; 78 coax, 400-900'; (4) R-R, mono; (4) mono cart machines; Marti RPU xmtr & antenna; Marti rcvr & antenna; CD players (2). J Setzer, POB 937, Brookfield MO 64628. 816-258-5310.

Need cart machines, phone hybrids, 12+ chnl console, EBS monitor, racks, TTs, CDs, mics, downlink, prod equip donations. J Carlson, KMUD, POB 135, Redway CA 95560. 707-923-2911.

Non-profit comm radio station seeks used audio console, RTRs, cart machines, phone couplers, TTs, studio & portable cass & mics for training student volunteers. S Perez, KZSC, Univ of CA Santa Cruz, Santa Cruz CA 95064. 408-459-2811.

FM Station needs translator, and to upgrade almost everything, tax deductible, we pay shipping. R Bendheim, PO Box 135, Redway CA 95560. 707-923-2513.

Kentucky High School seeks donation of used radio equipment for starting FM educational station. D Moore, Neison Co High School, 1070 Bloomfield, Bardstown KY 40004. 502-348-9046.

Educational FM needs donations of any kind of audio equip in any cond, will issue tax deductible receipt for amount of donation plus shipping cost. Mr. Nielson, 901-925-9236.

Australasia's only educational FM station seeks 2nd hand equip: cart machines, RTR, STL, etc. repairable, & adaptable to 240 V/50 Hz, will pay costs. P Olliver, 89 FM, Stephenson Street, Blenheim, New Zealand. 064 57 88520. FAX 064 57 80389.

Christian organization seeks donation of any prod equip, audio/video for ministering to the elderly. S Lanter, 513-444-3796 call collect.

Eng student desiring donation of old bldt equip (anything in repairable cond, will pay all shipping charges, EE student at Purdue. C Gill, POB 371, Indianapolis IN 46206. 317-923-2800.

TEST EQUIPMENT

Want to Sell

Heath scope IOW-12, gd cond w/book, \$60/BO; EICO 221 VTVM, gd cond w/book, \$25/BO. D Carver, KZBK, 107 S Main, Brookfield MO 64628. 816-258-7458.

Sencore VA-62, NT64, CV63, PR-57, all like new, \$2500. L Clinton, KARN, POB 4189, Little Rock AR 72214. 501-661-7500.

TEST EQUIPMENT

We Buy and Sell

All types of late model Test Equipment
Hewlett-Packard, Tektronix, Wavetek,
Fluke R.F. & Microwave a Specialty

G.V. BELL & ASSOCIATES

San Mateo, California
1-400-366-5240
(Inside 408/415 area)
415-366-5240
FAX 415-369-9698

Old test equip to sell or trade, includes Heathkit oscilloscope, color bar gen, resistance sub box, condenser sub box, iso trans, grid dip, ant imp, EICO multi tracer, Senco transistor checker, genometer, Sprague telomike, EICO 950, Cornell Dubilier, Jackson TVG-2, military signal generator & more, also lot of tubes. R Scott, Box 35, Canby CA 96015. 916-233-4106 or 233-5151.

Potomac Instruments AG-51, excel cond, \$1000. P Lancaster, Howard Schwartz Recd, 420 Lexington, Ste 1934, NY NY 10170. 212-687-4180.

RCA WX2D 3002-D field intensity meter, \$500. Chuck, 919-623-9966.

B&K 1260 rack mount video pattern/sync gen, like new cond, \$1100/BO. B Hoover, Colorburst Comm, Box 39, Valier PA 15780. 814-938-7237.

Bird 8745-677 20 kW water cooled dummy load w/3-1/8" EIA flange, \$995. G Liebis, WPTF, 919-876-0674.

Several pieces of equip from estate of the late T A Giles/PE. R Giles, 6189 Hwy 62, Georgetown IN 47122. 812-944-6786.

B&W 200 audio oscillator; B&W 400 distortion meter. Adolph, 915-949-2112.

Johnson Electronics STS-11 synthesized signal test set w/power pak. D Leinen, Independent Resources, POB 23498, Oklahoma City OK 73123. 405-721-1187.

Potomac FIM-41 field strength meter, less than 1 yr old, perfect cond, proof of calibration, \$2200. M Cooney, Dakota Bdct, POB 97, Brookings SD 57006. 605-692-1430.

Telemation TSG 3000 gndt sync gen, excel cond w/manual, BO; Telemation TMT 102, 101, 103, w/manuals, BO; Leader LCG 388 color bar gen, new, \$100. William, Lectrotech, 5810 N Western, Chicago IL 60659. 312-769-6262.

Kay Marka-Sweep 154C, clean, but needs some work, less markers, \$80. J Cunningham, KEOR, Rt 2 Box 113B, Stonewall OK 74871. 405-265-4496.

TEST EQUIPMENT

Why Buy When You Can Rent?
POTOMAC, DELTA, BIRD.
Other Equipment Available
Call For Rates and Availability

RADIO RESOURCES

1-800-54-RADIO
1-800-547-2346
301-859-1500

Sound Technology 1500A audio test system, automatically test & display on internal CRT, freq resp, 2nd/3rd HD, flutter, speed, separation, noise, more, vgc, includes operating & maintenance manuals, \$2690. D Martin, House of Music, 3100 Airway Ave, Costa Mesa CA 92626. 714-641-8000.

HP 330D dist analyzer, HP 200CD audio gen, Daven T893 attenuator network, \$150/set. L Collins, Collins Assoc., POB 422, Washington NH 03280. 603-495-3983.

Tek 520A vector scope, SN B438659, low usage, calibrated in last 6 mos, \$3000. B Broyles, Sunset Post, 1817 Victory Blvd, Glendale CA 91201. 818-956-7912.

Tektronix R561B scope w/3A6 dual trace preamp & 3B4 time base, needs repair, \$100/BO. L Albert, WKMS, POB 2266, Murray KY 42071. 502-762-4664.

Tek 1220 spectrum analyzer, 10 MHz-4200 MHz; Tek 547 oscilloscope main frame, sell sep or together, BO. C Springer, PO Box 890, Lamar CO 81052. 719-336-2206.

RCA Potomac WX-2D field meter w/book, gd cond, AM band only, new bats, \$500. D Jack, Min. Media. 208-286-7676.

MARATHON PRODUCTS COMPANY

Audio Cartridge Rebuilding Division

Rebuilding/reloading, like new, all brands, any length up to & including 2.5 minutes,
\$1.50 ea. FOB our plant, 48 hrs delivery.

New NAB Marathon cartridges prices on request.

35 Years professional experience!

Lifetime member AES R.D.MYERS Sr.

Manufacturers of Audio Devices, Continuous Tape Mag.

69 Sandersdale Rd.,
Charlton, MA 01507

1-508-248-3157 or 1-508-853-0988

Fluke 8050A digital multi-meter, like new, \$300/BO. J Claybrook, 530 Beacon Pky W, Birmingham AL 35209. 205-942-9600.

Want to Buy

Simpson 379 battery tester, will buy or swap Simpson 377/DC meter. J Roper, Imperial Snd, RR 31 Box 405, Terre Haute IN 47803. 812-877-2683.

Boonton 250A Need manual and schematics, copy OK. T O'Laughlin, Rt 1 Box 41, Barneveld WI, 53507. 608-924-2001.

TRANSMITTERS

Want to Sell

RCA BTE 15A FM exciter w/stereo generator & SCA generator. M Young, WJON, POB 220, St Cloud MN 56302. 612-251-4422.

McMartin BF25K 27.5 kW grounded grid, no PCBs, spare HVPS, circuit boards, transformers, in service, \$30,000. D Solinske, WWRM, POB 22000, St Petersburg FL 33702. 813-576-1073.

WANTED

Studio and Broadcast Equipment. Finders fee paid for locators. Don't take the chance of not being paid, sell to the oldest broadcast supply house in Latin America.

GUARANTEE RADIO SUPPLY CO.

1314 Iturbide
LAREDO, TX 78040
(512) 722-3233
(512) 727-8458 (fax)

Harris 3.5K, mint cond, \$23,000. R Wachter, KNSX, 3418 Douglas, Florissant MO 63034. 314-921-2121.

Jones-Tepco J-317 FM translator, 10 W, \$1400; antennas also available. D Silver, KNKK, Layton Hills Mall, Layton UT 84041. 801-973-7759.

LEASING AVAILABLE ON USED TRANSMITTERS AMERICAN BROADCAST FINANCIAL CORPORATION 414-482-2638

Thomson-LGT EVHF-10S LPTV, 10 W, high band VHF, near new, Ch 9, \$4500/BO. L Baley, LPTV, 3317 Barrow Hill Tr, Tallahassee FL 32312. 904-893-1382.

Collins 21E 5 kW AM, gd workd cond, original owner, \$5000. C Webster, WGVM, 1383 Pickett, Greenville MS 38701. 601-334-4559.

Gates BC-1F 1 kW AM, excel cond, \$2000. J Kramden, WBRL, 3342 Perry Rd, Marsellus NY 13215. 315-673-9049.

RCA BTE-10C/BTS-1A exciter, stereo gen, metering panel & CBS stereo Volumax in 4" rack w/spares, complete 10 W xmt, will sell separately, \$700 pls shpg. T O'Laughlin, O's Own Labs, Rt 1 Box 41, Barneveld WI 53507. 608-924-2001.

CSI 3 kW FM, 93.5 MHz, 600', 1-5/8" foam filled coax, isocoupler, 3 bay antenna, Gates 1 kW AM xmt for parts. K Holcombe, WJJK, POB 350, Evergreen AL 36601. 205-578-2780.

INR Tech Mdl 1000 drive-buy radio transmitter, synthesized FM xmt for advertising message, uses standard endless cassette tape for message, new in box, \$425/BO. M Peterson, 3610 Lancaster Ste 6, Plymouth MN 55441. 612-544-6391.

McMartin BF25K-FM, 1979 27.5 kW w/low pwr cut back, grounded grid, spare HVPS & boards, panels, iron from stripped second unit, \$30,000. D Solinske, WWRM, POB 22000, ST Petersburg FL 33742. 813-576-1073.



High performance at affordable prices.

- New front panel programmable composite STL's.
- New directly programmable FM composite receivers
- New options for synchronous boosters and translators
- New FM exciters, transmitters, amplifiers: 2W to 30kW
- Same old price, quality, service and reliability

Bext, Inc.
739 Fifth Avenue.
San Diego, CA 92101
619-239-8462
Telex 229882 Fax 619-239-8474

RCA 250M excel cond, less than 500 hrs, full power, clean, you pick up, BO. LJ Maierhofer, WTGC, 101 Armory, Lewisburg PA 17837. 717-523-3271.

Nautel AMPFET 10 AM solid state, 1510 kHz, 2.5 yrs old, excel cond, includes spares, etc, towers, ATU's, (4) tower phasor, will negotiate. B Williamson, WALL, One Bdct Pl, Middletown NY 10940. 914-343-7400.

Harris plate transformer for MW 5A, new, in crate, \$1000/BO. J Long, 4452 Hoblan Ct, Hixson TN 37343. 615-877-9000.

FM TRANSMITTERS

10 kW
1970 CCA 10000D
12 kW
1979 CSI 12000E
20 kW
1976 Collins 831-G2B
PMA Marketing
414-482-2638

Johnson Viking I 100 W shortwave xmt, vfo ham bands 80-10m, AM, \$75. J Feasel, 13549 Morse, Pataskala OH 43062.

RCA BTF 20E1, to trade for Harris or Collins 1-10 kW FM xmt. J Mauk, KMJ, POB 70002, Fresno CA 93744. 209-266-5800.

Harris MW1, 500 W D 1520 Hz, like new, BO. HS Kilgore, KMPG, POB 1507, Hollister CA 95023. 408-637-7476.

RCA BTA-5L 15 yrs old, 5 kW AM, great shape, \$15,000; Collins 21E 5 kW AM, great shape but needs new HV transformers for pwr reduction, \$5,000; Gates FM250B, works great, fully rematable, \$1200. S King, KIXZ, 1705 Avondale, Amarillo TX 79106. 806-355-9777.

Collins 830D 1 kW FM, original exciter, 1960's vintage. B Umberger, WNLT, 51 S Main, Clearwater FL 34625. 813-446-0957.

TOP DOLLAR

For Your Old Transmitter, STL or Exciter!
Call for a quote
We arrange quick dismantling & removal PCB's? No Problem Call Us.

ARMSTRONG TRANSMITTER CORP.
5046 Smoral Rd
Syracuse, NY
(315) 488-1269
FAX (315) 488-1365



ARMSTRONG TRANSMITTER

FM TRANSMITTERS

250W Collins 731A
1kW Collins 830-d1
3kW RCA BTF-3B
5kW Gates FM 5-B
5kW Harris FM 5-H
10kW RCA BTF-10C
12kW AEL 12,0000KG
15kW Sintronics S1-1-15
20kW Collins 831-G2
20kW CCA 20,000E
20kW CCA 20,000D
20kW RCA 20-E1
25kW McMartin BF25-K

AM TRANSMITTERS

1kW Collins 1K
5kW Gates BC-5B
5kW RCA BTA-5T
5kW Collins 21-E
10kW RCA BTA-10H
10kW Harris MW-10
10kW Sparta 10kW
50kW GE BTC-50C
50kW RCA BTA-50G
50kW Harris MW-50

ARMSTRONG TRANSMITTER CORP.

5046 Smoral Road (315) 488-1269
Syracuse, NY FAX (315) 488-1365



GE BT 22-A all gd tubes & manual, as is, \$5000 pls shpg. S Weber, KGRV, POB 1598, Winston OR 97496. 503-679-8185.

Gates FM-10G w/Wilkinson FME-10 exciter at 102.7. M Ripley, KOZE, Box 936, Lewiston ID 83501. 208-743-2502.

Harris FM-5 H3 5 kW FM tuned to 98.1 MHz w/TE-3 exciter & documentation, avail immed, \$14,000. F Giardina, Dittman Group, 2146 Highland, Birmingham AL 35205. 205-933-9274.

Home brew 50 W AM, will set to your freq, \$500. J Cunningham, KEOR, Rt 2 Box 113B, Stonewall OK 74871. 405-265-4496.

Bird Teraline 8732 coaxial resistor, water cooled dummy load, 10 kW 50 ohms, \$400. C Benner, WUSL, 440 Domino, Phila PA 19128. 215-483-8900.

Lea SE-1201/240-60-2 xmt line voltage surge protector for xmt or studio unit, new, \$1400. K Austin, KFXI, POB 392, Marlow OK 73055. 405-658-9292.

QEI 695T 3.5 kW, avail after 1/90, includes QEI 695 exciter & spare parts kit, \$18,000. K Austin, KFXI, POB 392, Marlow OK 73055. 405-658-9292.

RCA rack mount TV text xmt, low pwr, chnl 12, w/manual, \$150 pls UPS. G Kirby, Marysville Bacs, 13613 US 36, Marysville OH 43040. 614-261-8871.

Up To \$500 REWARD

For information leading to the purchase of used AM/FM Transmitters

- \$500 for most 20-30kW FM
- \$250 for late model FM's 5-20kW
- \$100 for any FM over 1kW & any AM newer than 1975



ARMSTRONG TRANSMITTER CORP.
5046 Smoral Road (315) 488-1269
Syracuse, NY FAX (315) 488-1365

Harris Transmitter MW1 one thousand watts, exc. cond. BO; H Kilgore, PO 1507, Hollister CA 95023. 408-637-7470.

RCA BTA-1M 1000watt, AM, Gd. cond. \$2500. C Ratliffe, #1 Radio Street, Wadesboro NC 28170. 704-694-2175.

Kintron Power Reduction Kit New, set up to reduce 1kW to 222 watts, easily modified. \$800. P Beal, Burem Road, Rogersville, TN, 37857. 615-272-3900.

Gates BC1J Operational, some spare pls, spare tubes, inc. 833's. BO. P Beal, Burem Road, Rogersville TN, 37857. 615-272-3900.

RCA BTA 50 F 50 kW AM, fully operational, many extras, \$16,000 pls shpg; RCA BTA 5F 5kW AM, excel cond, wall floor layouts, manuals, tubes, etc, \$9000 pls shpg; RCA new mod transformer for BTA 5F xmt in original crate, \$600 pls shpg. G Heidenfeldt, 2880 W Lake, Wilson NY 14172. 716-751-6187.

Pomar Electronics

WANTS USED

TRANSMITTERS & EQUIPMENT

For the best deals call

Oscar Pomar

1615 STA. MARIA AVE.
LAREDO, TEXAS 78040

(512) 722-9437

FAX: 512-722-1795

CCA 5000G 1987 FM xmt w/exciter, like new, \$18,683/BO. L Torgersen, WOIC, Box 5353, Meridian MS 39302. 601-693-4851.

SUPER-GEN

This high-performance FM Stereo Generator has selectable pre-emphasis, overshoot-controlled lowpass filters, digital pilot/subcarrier synthesis and built-in overmod protection. CBS/NAB's "FMX" system is available as a plug-in option.

Inovonics
SANTA CRUZ, CA (408) 458-0552

Wilkinson 1000A 1976 mdl tuned to 1300KC, BO. B Hearst, WWCH, PO Box 688, Clarion PA 16214. 814-226-5800.

Harris FM2.5K w/MS-15 excit, avail. mid-Dec. \$12,000. You pick up/ship. J Tudor, WMNC/WOXX, PO Box 969, Morgantown NC 28655. 704-437-0521.

RCA BTA-250L tuned to 1230 kHz w/manual & some spare tubes, BO. D Niccum, KOZA, 1301 S Crane, Odessa TX 79760. 915-333-3101.

TRANSCOM CORP.

Fine Used AM & FM Transmitters and Also New Equipment
For the best deals on Celwave products, Andrew cable, Shively & Comark antennas.

1980 CCA 28,500 FM
1980 Harris FM 20 K
1976 RCA BTF 20E1
1978 Collins 5 kW AM Power Rock
1984 McMartin BF 3.5 K
1976 CCA AM 50,000D, 50 kW AM
1979 Harris MWIA

201 Old York Rd.
York Plaza Ste 207
Jenkintown PA 19046
215-884-0888

Telex No. 910-240-3856 (TRANSCOM CORP. UQ)
FAX No. 215-884-0738

TRANSMITTERS . . . WTS

RCA BTF-10D currently in use and in gd cond w/new power tube, \$9000. J McBride, Box 464, Osceola IA 50213. 515-342-6536.

Harris MS-15 exciter w/100 W RF amp, \$2500; TTC FM-300J transmitter w/8090 exciter, solid state, \$7500. G Gaskey, Box 158, Weed CA 96094. 916-938-3828.

RCA BTF-20E1 new and used spare parts. Engineering, MSE Ltd, 941 Lobelia Ave, Reading PA 19605. 215-921-0477.

Peter Dahl replacement mod transformer for Gates BC-5P2 AM xmr, new, W Robinson, 2110 Cliff Road, Eagan MN 55122. 612-452-6200.

McMartin BF-25K 275 kW FM, w/13910 exciter, driver stage can be used if final fails, on air at 26.5 kW, will ship upon sale, \$23500/BO. C Springer, PO Box 890, Lamar CO 81052. 719-336-2206.

QEI 675 programable freq up to 25 W, excel cond w/new manual, \$1200. V Clough, 225 Green St, Fayetteville NC 28302. 919-486-4991.

Collins 831G 90% complete, but cabinets damaged in shipping, needs low pass filter, filter capacitor & other small items. Low time unit, cavity very gd cond, \$11,000. M Vande Voort, Rte 3 Box 214, Pella IA 50219. 515-628-1724.

Want to Buy

Gates BCA 250 or Temco 250 BCA or other physically small AM rig in 100-500 W range. J Vile, WHOT, 4040 Simon, Youngstown OH 44512. 216-783-1000.

WANTED

AM and FM Transmitters, all powers. Finders fee for locators. DON'T take the chance of not being paid, sell to the oldest broadcast supply house in Latin America.

GUARANTEE RADIO SUPPLY CO.

1314 Iturbide LAREDO, TX 78040 (512) 722-3233 (512) 727-8458 (fax)

Versacount V-322 FM Exciter instruction manual or schematics needed. R Schlosser, 320 Market Street, Steubenville OH 43952. 614-283-4747.

FM exciter, 10 W, any make, any cond. P Hons, 100 Poplar, Portage PA 15946. 814-736-3883.

Low-band VHF xmr, chnl 4, 20 Kw & 6, 20 kW or higher pwr w/VSB filer, harmonic filters. J Fuehrer, NTV Network, POB 220, Kearney NE 68848. 308-743-2494.

FM transmitter 1 kW FM for stand-by service, tube exciter OK. B Brigham, Locust & High Street, Montrose PA 16801. 717-278-2811.

TTC T99 VHF, 1 watt translators, immediate need for ch-13 in to ch-3 output for solar powered site. F Leitch, PO Box 874, LaGrande OR 97850. 503-963-4338.

Solid state 1 kW AM xmr. J Frew, 1410 Hwy 411 NE, Cartersville GA 30120. 404-382-1270.

FM xmr 5 kW or greater, 4 bay low pwr antenna 101.3 Mhz & all types of studio equip. G Vaile, 723 West 14th, Little Rock AR 72202. 501-375-1440.

Used TV xmtrs, antennas & rigid line, one watt to 60 kW. Fair market price paid. Turn-key handling. Call Broadcasting Systems, Kenneth Casey, 602-582-6550.

TUBES

Want to Sell

Tek CRT's for 528, 528A, & 1420 video monitors. A Weiner, Britton Rd, Monticello ME 04760. 207-538-9538.

REBUILT ELECTRON TUBES

Partial List: 6623, 23791, TH150, 6425F, 5604, 6696, 6697, 5681, 5682, 5671, 7804, 3CX10, 000H3, 3CX20, 000H3, 4CX5000A, 4CX35, 000C

Vacuum Tube Industries, Inc.

1-800-528-5014

Varian/Eimac 4CX5000A, new tubes in factory sealed cartons (2), \$500 ea. E Swanson, WZTR, 520 W Capitol, Milwaukee WI 53212. 414-964-8300.

Eimac 4-400A (4) new, \$88 ea; many other tubes in stock, most new. M Brown, KKGR, 503-245-4689.

TUBE REBUILDING

FREELAND PRODUCTS

Since 1940 SAVE ABOUT 50% —We buy dud tubes—

800-624-7626

504-893-1243

FAX 504-892-7323

Econco 6166A/7007 RCA, never used, \$1800. M Nowak, WBKB, 1390 Bagley, Alpena MI 49707. 517-356-3434.

Penta Labs super premium output tubes w/increased plate dissipation, unused, KT-88; EL-34, \$12. R Katz, 15015 Ventura Blvd, Sherman Oaks CA 91403. 818-377-5264.

3CX1500A7, 4CX5000A, 6146B, 4CX2508, 4CX3000A & more. We carry large inventory all major brands, Eimac, Ampere, RCA, etc. Call Stew 1-800-842-1489.

Want to Buy

ELECTRON TUBES

Partial List: 6623, 23791, TH150, 6425F, 5604, 6696, 6697, 5681, 5682, 5671, 7804, 3CX10, 000H3, 3CX20, 000H3, 4CX5000A, 4CX35, 000C

Vacuum Tube Industries, Inc.

1-800-528-5014

We buy electron tubes.

Contact us if you have any for sale.

PATH

507 Superior Ave. Newport Beach CA 92663 714-722-6733

tubes wanted 6072/6072A (no RCA). R Katz, 15015 Ventura Blvd, Sherman Oaks CA 91403. 818-377-5264.

TURNTABLES

Want to Sell

Rek-O-Kut N-33H 12" TT, \$25 pls UPS. G Kirby, Marysville Bacs, 13613 US 36, Marysville OH 43040. 614-261-8871.

Gates 6169 solid state stereo preamp, 600 ohms line level out. L Beigel, POB 85042, LA CA 90072. 213-466-3595 or FAX 213-466-3596.

Sony TTS-3000 belt-driven table w/PVA-237 arm, all manuals, as is, \$30. W Laughlin, 753 Ruth Ln, Hurst TX 76053. 817-282-9033.

QRK 12-C TT's (2) w/Gray tone arms & carts, vgc, \$130/BO; M Brown, KKGR, 503-245-4889.

Technics SP-15, new, full factory warranty, were \$980 list, now only \$490 while supplies last. Call NEBL 518-793-2181.

Russco Cue Master 12" TT's w/Micro-trak 303 arm, gd cond, you ship, \$250. R Kerbawy, Box 1127, Beckley WV 25802. 304-877-5592.

Scully lathe w/Westrex Davis fluid drive; Westrex 3DII stereo cutting system, vacuum turntable & electric variable pitch modifications by Wiegand Audio, \$5000. L Nesman, 3108 York St, Wichita Falls TX 76309. 817-696-1629.

Rek-O-Kut V 3 speed, 16" recording lathe w/105, 120 & 210 feed screws, factory modified for crank feeding & feed-out, \$150. L Nesman, 3108 York St, Wichita Falls TX 76309. 817-696-1629.

TV FILM EQUIP

Want to Sell

RCA TP-66 projector, optical sound only, \$2240. J Fuehrer, NTV Network, POB 220, Kearney NE 68848. 308-743-2494.

Bell & Howell JAN 614 16mm magnetic & optical sound telecine projector, portable, fair cond, \$195. G Ormrod, 432 East X Street, Tumwater WA 98501. 206-352-8028.

VIDEO PROD EQUIP

Want to Sell

Sigma VPA-100 video processing amp, \$50 pls UPS. G Kirby, Marysville Bacs, 13613 US 36, Marysville OH 43040. 614-261-8871.

Telemation TSE200VS special effects gen, 6 inputs, 8 wipes & keyer. BO. M Cramer, WGBA-TV, 1391 North Rd, Green Bay WI 54307. 414-494-2626.

Amtron AM17 17" color monitor, rack mount, inline gun type, \$200. H Larson, Matrix TV, POB 536, San Luis Obispo CA 93406. 805-544-5657.

RCA HR2 edit recorders & (2) M1 Format built-in T & B & C's, cases, etc, \$2000; HE1 edit controller together, \$4000. System needs minor work. A Romanoff, 374 N Ridgewood Place, Los Angeles CA 90004. 213-467-1700.

Faroudja record ex image enhancer, battery/AC operated, works great, \$200; (2) Sony edit cables for type 5/440, \$50/ea; Fostex 8753 interface, \$300. A Romanoff, 374 N Ridgewood Place, Los Angeles CA 90004. 213-467-1700.

M1 Format Production Package, System needs minor work, \$8000 complete. A Romanoff, 374 N Ridgewood Place, Los Angeles CA 90004. 213-467-1700.

Barco CTVM2-38 15" color monitor, rack mount 9 mHz bandwidth trigun type, \$500. H Larson, Matrix TV, POB 536, San Luis Obispo CA 93406. 805-544-5657.

Buhl mobile multiplexer w/(2) Ektagraphic 35mm slide projectors, (2) 100-150 mm zoom lens, (2) projector cases, Sharp RD685 sync recorder, (4) Carousel trays, (2) 80's, (2) 140's, (2) spare 300W quartz bulbs, \$1875. B Hines, IPS, Rd 1 Box 413A, Export PA 15632. 412-468-4115.

RCA Hawkeye Camcorder, \$6000; IGM VG2000P Prod. amp, cleans up sync, luminance & pedestal, chroma phase, (4) video outposts & 2x4 audio DA, \$500. A Romanoff, 374 N Ridgewood Place, Los Angeles CA 90004. 213-467-1700.

CBS Labs 529 image enhancer (2), horz & vert equalizing, BO. M Cramer, WGBA-TV, 1391 North Rd, Green Bay WI 54307. 414-494-2626.

Panasonic AG1950 (2) VHS editing system w/AG95A edit controller, excel cond, \$1750. J Winslow, Creative Video, 716 Prescott, Endicott NY 13760. 607-754-6767.

5850 w/address track mod, low hrs since overhaul, excellent machine, \$4000; \$600 address track mod & shuttle conversion to work as edit source, well maintained, \$2500. A Romanoff, 374 N Ridgewood Place, Los Angeles CA 90004. 213-467-1700.

JVC 8250, 5500 A/B roll editing 3/4", Abner editor, like new, low hrs, cables & monitor, \$12600/all. Jack, 203-264-3666.

Sigma CSG355 video sync gen w/bars, black burst, hdr, vdr, etc, \$900 plus shpg. M Holdwin, Anamnesia Studios, 40 S Oxford St, Brooklyn NY 11217. 718-852-7630.

Adda VV-2 frame synchronizer, has freeze frame/field, gd cond, \$9000. T Pelissero, 612-378-1254.

Ball 9" B/W monitors (3), \$15/ea, plus shpg. M Holwin, Anamnesia Studios, 49 S Oxford St, Brooklyn NY 11217. 718-852-7630.

Hitachi SU-340 3/4" & portable w/2 batteries inc AC adapter/charger, \$670. D Lasko, 3054 Gold Canal Ste D, Rancho Cordova CA 95670. 916-638-7770.

Videotek KV1365 12" color video monitor w/blue gun, \$250 plus shpg. M Holdwin, Anamnesia Studios, 40 S Oxford St, Brooklyn NY 11217. 718-852-7630.

JVC RM86U control track editor controller, \$850 plus shpg. M Holdwin, Anamnesia Studios, 40 S Oxford St, Brooklyn NY 11217. 718-852-7630.

ESE ES255 limecode reader, burn-in/window dub unit, \$400 plus shpg. M Holdwin, Anamnesia Studios, 40 S Oxford St, Brooklyn NY 11217. 718-852-7630.

Want to Buy

Sony RM-400 edit controller w/cables in fair-gd cond. P Badger, Box 104, Birdsnest VA 23307. 804-442-4037.

Digital timer for TCA TR-60 videotape recorder. J Fuehrer, NTV Network, POB 220, Kearney NE 68848. 308-743-2494.

VVEarly TV cameras & studio equip, also early & pre-war TV sets, R Van Dyke, Caffrey House, Squires Ave, E Quogue NY 11942. 516-728-1327.

Tektronix 1450 or 1450-1 television demod & tektronix TDC-1 tuneable downconverter, VHF band. J Fuehrer, NTV Network, POB 220, Kearney NE 68848. 308-743-2494.

Grass Valley 906A video AGC module. J Fuehrer, NTV Network, POB 220, Kearney NE 68848. 308-743-2494.

VIDEO TAPE RECORDERS

Want to Sell

JVC CR4400U 3/4" port recorders (4) w/access, \$800 ea/BO; (3) Sony RM-430 edit controllers, \$500/BO; JVC BR-6400U VHS recorder, \$1500/BO. T Quinn, Monte Vista St, 208 Cherry, Capitola CA 95010. 408-475-0423.

Sony VO-3800 & AC-3000 low time, works fine, \$300. L Albert, WKMS, POB 2266, Murray KY 42071. 502-762-4664.

JVC CR-4700U 3/4" portable recorder, w/AAP47U AC pwr supply/charger, (3) Nicads, custom case, low hrs, excel cond, \$2095. B Hines, IPS, Rd 1 Box 413A, Export PA 15632. 412-468-4115.

Ampex VR-1200-B videotape recorder, \$1000. J Fuehrer, NTV Network, POB 220, Kearney NE 68848. 308-743-2494.

Panasonic NV9500, NV9200 3/4" edit system w/NV950 edit controller, gd cond; other 9500, 9200 available, \$1000/set. H Larson, Matrix TV, POB 536, San Luis Obispo CA 93406. 805-544-5657.

Ampex VR-1200B 2in quad (2), manuals, test tape, 3 spare heads, \$1500/both. P Badger, POB 104, Birdsnest VA 23307. 804-442-4037.

Sony 6800 portable w/cover, 100 hrs use, \$1700. M Nowak, WBKB, 1390 Bagley, Alpena MI 49707. 517-356-3434.

WORLDWIDE DIGITAL CONVERSION

ALL FORMATS BROADCAST QUALITY Pal Multi-dupe/Hi-Band/1"

TK VIDEO 12300 Coppola Drive Potomac, MD 20854 301-762-2786

Sony VO-2610 3/4" RP, \$500; (2) Panasonic NV9100A 3/4" players, \$350 ea; (2) Sony VO-2600 3/4" RP, \$450 ea; Sony VP-1200 3/4" player, \$200, plus UPS. N Mishan, POB 335, Lynbrook NY 11563. 516-582-1338.

JVC 8500LU (2) fair working, (3) for parts, BO. D Aase, KXMC-TV, Box 1686, Minot ND 58702. 701-852-2104.

JVC 4400LU (2) working & (2) for parts, BO. D Aase, KXMC-TV, Box 1686, Minot ND 58702. 701-852-2104.

NEC TT 7000 1" VTR w/TBC, low hrs, gd cond, \$8000. D Lahey, Pathfinder Prod, 17094 McGuffie Rd, Salinas CA 93907. 408-663-5192.

JVC 3/4" CP5050U industrial player w/RF output & remote control, \$475. B Hines, IPS, Rd 1 Box 413A, Export PA 15632. 412-468-4115.

JVC BR6400 1/2" VHS R/P, \$850 plus shpg. M Holdwin, Anamnesia Studios, 40 S Oxford St, Brooklyn NY 11217. 718-852-7630.

JVC CR6600 3/4" R/P, \$1000 plus shpg. M Holdwin, Anamnesia Studios, 40 S Oxford St, Brooklyn NY 11217. 718-852-7630.

JVC HR-4100AU 1978 industrial VHS portable w/camera, charger & battery, gd cond, \$150/trade. D Lasko, 3054 Gold Canal, Ste D, Rancho Cordova CA 95670. 916-638-7770.

ACTION-GRAM

Equipment Listings

Radio World's Broadcast Equipment Exchange provides a FREE listing service for all broadcast and pro-sound end users. Simply send your listings to us, following the example below. Please indicate in which category you would like your listing to appear. Mail your listings to the address below. Thank you.

Please print and include all information:

Contact Name: _____

Title _____

Company/Station _____

Address: _____

City _____ State _____ Zip _____

Phone Number: _____

Brokers, dealers, manufacturers and other organizations who are not legitimate end users can participate in the Broadcast Equipment Exchange on a paid basis. Listings are available on a \$25/25 word basis. Call 1-800-336-3045 for details and complete display rates.

I would like to receive or continue receiving Radio World FREE each month. YES NO

Signature _____ Date _____

Please circle only one entry for each category:

I. Type of Firm

- D. Combination AM/FM station
- F. Recording studio
- A. Commercial AM station
- G. TV station/teleprod facility
- B. Commercial FM station
- H. Consultant/ind engineer
- C. Educational FM station
- I. Mfg, distributor or dealer
- E. Network/group owner
- J. Other _____

II. Job Function

- A. Ownership
- D. Programming/production
- B. General management
- E. News operations
- C. Engineering
- F. Other _____

WTS: WTB: Category: _____

Make: _____ Model #: _____

Brief Description: _____

Price: _____

WTS: WTB: Category: _____

Make: _____ Model #: _____

Brief Description: _____

Price: _____

Broadcast Equipment Exchange

703-998-7600

PO Box 1214 • Falls Church VA • 22041

FAX: 703-998-2966



ARMSTRONG TRANSMITTER

TUNED, TESTED, WARRANTED

We are the leading remanufacturer of radio transmitters with customers worldwide.

Our transmitters are available:

- * Tuned & Tested on YOUR Frequency
- * Guaranteed
- * Installed
- * Completely re-manufactured

See before you buy, visit our showroom

Why spend a fortune on a new one?

ARMSTRONG TRANSMITTER CORP.

5046 Smoral Road (315) 488-1269
Syracuse, NY FAX (315) 488-1365



MARKETPLACE

Send us your new product info. Be sure to include a black and white photo. Send all submissions to Radio World Marketplace, P.O. Box 1214, Falls Church, VA 22041



EBS monitor

The System 3000 EBS monitor from Multi-Technical Services incorporates three monitor receivers, the EBS encoder and decoder in one unit.

Additional features include three channel scan, continuous automatic self test, NOAA weather service receiver, NOAA priority alert decoder, remote operation, built-in monitor speaker, monitor outputs and alarm outputs.

The System 3000 receivers are modular fixed tuned devices and are interchangeable; they are housed in die-cast enclosures for maximum RF immunity. The unit requires no programming for operation.

For information, call Lynwood Williams at Multi-Technical Services: 919-553-2995, or circle Reader Service 64.



Power conditioner

Liebert Corporation has redesigned its Datawave® power conditioners (in 50 and 75 kVA models) to make them easier to include in computer room layouts.

The redesigned models have a footprint that measures 44" x 32", 37% smaller than the older models.

For information, call Dick Pulse at Liebert Corporation: 614-841-5778, or circle Reader Service 8.

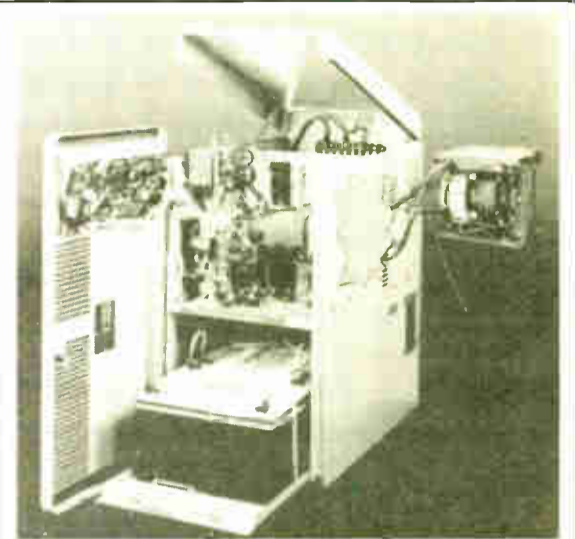

Service plans

Three customer service plans now are available to users of uninterruptible power systems from Best Power Technology, Inc.

For information, call Ed Coudal at Best: 312-520-5773, or circle Reader Service 76.



Synchronous FM system

TFT's new synchronous FM broadcast system, the Reciter, is designed to replace the STL receiver and FM exciter at an FM transmitter site. It combines the functions of such equipment, with an IF interface between them. This avoids bringing the signal down to baseband. The unit also provides synchronization of phase, frequency and modulation level to an FM booster system.

For information, call Jesse Maxenchs at TFT: 408-727-7272, or circle Reader Service 79.



Pro dynamic headphones

The HD 25 studio monitoring headphone from Sennheiser features dynamic drivers in a closed supraural design, an adjustable split headband and single side audio cable.

For information, call Tony Tudisco at Sennheiser: 203-434-9190, or circle Reader Service 22.



Noise reduction cards

THAT Corporation is shipping new, reduced-cost dbx 321 series noise reduction circuit cards for preserving the quality of audio signals transmitted via satellite, microwave, and cable links. The cards are 100% compatible with other 321 models.

For information, call Les Tyler at THAT Corp.: 508-653-6335, or circle Reader Service 57.

Subscription/Reader Service Form

Radio World

February 7, 1990 Issue Use until May 9, 1990

FREE Subscription/Renewal Form

I would like to receive or continue receiving Radio World FREE each month. YES NO

Signature _____ Date _____

Please print and include all information:

Name _____ Title _____

Company/Station _____

Address _____

City _____ State _____ ZIP _____

Business Telephone () _____

Please circle only one entry for each category:

I. Type of Firm

- | | |
|------------------------------|---------------------------------|
| D. Combination AM/FM station | F. Recording studio |
| A. Commercial AM station | G. TV station/teleprod facility |
| B. Commercial FM station | H. Consultant/ind engineer |
| C. Educational FM station | I. Mfg, distributor or dealer |
| E. Network/group owner | J. Other |

II. Job Function

- | | |
|-----------------------|---------------------------|
| A. Ownership | D. Programming/production |
| B. General management | E. News operations |
| C. Engineering | F. Other (specify) _____ |

III. Purchasing Authority

- | | | |
|--------------|------------|------------|
| 1. Recommend | 2. Specify | 3. Approve |
|--------------|------------|------------|

Reader Service

Please first fill out contact information at left. Then check each advertisement for corresponding number and circle below. NOTE: Circle no more than 15 numbers, otherwise card will not be processed.

- | | | | | |
|-----|-----|-----|-----|-----|
| 001 | 021 | 041 | 061 | 081 |
| 002 | 022 | 042 | 062 | 082 |
| 003 | 023 | 043 | 063 | 083 |
| 004 | 024 | 044 | 064 | 084 |
| 005 | 025 | 045 | 065 | 085 |
| 006 | 026 | 046 | 066 | 086 |
| 007 | 027 | 047 | 067 | 087 |
| 008 | 028 | 048 | 068 | 088 |
| 009 | 029 | 049 | 069 | 089 |
| 010 | 030 | 050 | 070 | 090 |
| 011 | 031 | 051 | 071 | 091 |
| 012 | 032 | 052 | 072 | 092 |
| 013 | 033 | 053 | 073 | 093 |
| 014 | 034 | 054 | 074 | 094 |
| 015 | 035 | 055 | 075 | 095 |
| 016 | 036 | 056 | 076 | 096 |
| 017 | 037 | 057 | 077 | 097 |
| 018 | 038 | 058 | 078 | 098 |
| 019 | 039 | 059 | 079 | 099 |
| 020 | 040 | 060 | 080 | 100 |

ADVERTISER INDEX

This listing is provided solely for the convenience of our readers. Radio World assumes no liability for inaccuracy.

Page No.	Advertiser	Reader Service No.	Page No.	Advertiser	Reader Service No.	Page No.	Advertiser	Reader Service No.
09	3M	20	27	BSW	35	30	Modulation Sciences	31
06	Allied Broadcast	84	04	Burk Technology	33	12	Northeast Broadcast Labs	94
08	Allied Broadcast	21	36	CCA	97	37	Northeast Broadcast Labs	58
21	Allied Broadcast	52	14	Comrex	50	26	Orban Associates	69
31	Allied Broadcast	15	08	Continental Electronics	10	47	Panasonic/Technics	47
32	Allied Broadcast	75	37	Cortana	2	34	QEI	30
24-25	Arrakis Systems	17	10	CRL	42	17	RF Specialties	54
07	ATI	61	22	Cutting Edge	60	10	Sescom	77
29	Audio Broadcast Group	81	22	Dataworld	44	21	Sony	—
22	Audiopak	19	11	Delta Electronics	16	13	Studer Revox	88
35	Audionics	6	23	Dolby Labs	48	33	Studer Revox	99
31	Belar	56	28	Eventide	92	18	Tannoy	46
10	Bext	86	01	Fidelipac	29	17	Western International Co	40
03	Bradley Broadcast	3	19	Gentner	13/90	02	Wheatstone	14
03	Broadcast Electronics	45	20	Harris	66	48	Wheatstone	26
16	Broadcast Electronics	12	12	Microwave Filter Co	27			
18	Broadcasters General Store	63						

Advertising Sales Representatives:

East Coast, Art Constantine:	800-336-3045	Fax: 703-998-2966
Midwest, Mike Dahle:	914-762-3572	Fax: 914-762-3107
West Coast, Pat Macsata:	415-786-2198	Fax: 415-786-2754



THE PROFESSIONAL CD PLAYER FOR THE PROFESSIONAL CD PLAYER.

Like all professional CD players, the new Technics SL-P1300 is technologically advanced.

But you don't have to be a technical genius to operate it.

In fact, even if you haven't spent years in the studio, it will only take you a few minutes to figure it out.

You see, the SL-P1300 is ergonomically designed to give you greater control over playback than you've ever had before.

Perhaps that's because it's built like a recording console. Which means the disc well and all the other controls are right at your fingertips.



First, the control panel features a long stroke sliding pitch control. It's continuously variable with a range of $\pm 8\%$. In addition, it lets you restore quartz lock accuracy at the touch of a button.

There's also our two-speed search dial with audible pause. Which makes finding your in point extremely easy.

Our professional CD player has other features professionals enjoy working with. Like one-touch memorization by time code, A-B repeat, and our exclusive rocker control search buttons. It's the digital equivalent of dragging your

finger on the edge of a record.

A great deal of thinking also went into things like our balanced outputs (-10 dBm nominal into 600 ohms). There's even a port for a wired remote. And separate power supplies for digital and analog circuits. Given this, it's not surprising that its S/N ratio is 112 dB.

If you're a professional CD player, chances are you're ready to hear what our professional CD player can do.

Call your Technics representative. You'll find that our pro CD player isn't the only thing from Technics that's a pleasure to work with.

Technics
The science of sound



"Many of the headaches associated with building a new studio were eliminated with the WHEATSTONE pre-wire package. Set up and wiring of WAZU was a breeze. The furniture is solid and good looking, quick and easy to assemble—many hours were saved. Our jocks love the easy straight-forward layout of the new A-500 air console... and, after a quick and easy production room installation, little time was needed teaching the staff how to use the new multi-track studio; operators familiar with an on-air console adapt themselves easily to the SP-6 stereo console and the easy ways to insert special effects and audio processing—operation is so simple!"

John Soller, chief engineer at WAZU

Radio is Starting to Experience a Shortage: *Technical Experts*

Let our experts supply your prewired studio, consoles, studio furniture and audio system engineering. We'll help with your design, then build, wire, test and document your whole studio furniture installation—all at our factory. This takes a *major* load off your technical people and ensures project completion on time.

When Osborn Communications decided to upgrade member station WAZU in Dayton, Ohio, they chose WHEATSTONE for the job. With 12 rooms of Wheatstone consoles already installed, the Osborn people are well qualified to vouch for our commitment to client satisfaction.

Draw on our experience and reputation. Get a great looking studio with cutting edge performance. Contact WHEATSTONE—the experts!

 Wheatstone® Corporation

6720 V.I.P. Parkway, Syracuse, NY. 13211 (TEL 315-455-7740 /FAX 315-454-8104)

Circle 26 On Reader Service Card

World Radio History