

Radio World®

Vol 13, No 21

Radio's Best Read Newspaper

November 8, 1989

FCC STL Deadline Imminent

by John Gatski

Washington DC A fast-approaching FCC deadline on STLs has sent broadcasters scurrying for assurance from manufacturers.

Despite industry confusion about a 1 July 1990 deadline for type-notifying all STLs, manufacturers said they are willing to take on the burden of certifying current STLs that meet FCC-specifications.

Companies are less certain, however,

about how far they are willing to go in helping stations upgrade older STLs that may need expensive modification in order to meet the specifications.

Moseley Associates said it will undergo the type notification process for the majority of its post-1978 PCL-505s in order to comply, but that older models may need costly modification, which the company may not provide.

TFT now is testing several pre-1985 STLs to see if they meet FCC performance requirements, but some are likely

to need modification, a company official said.

Marti Electronics already has filed for type notification for its STL-10s and older STL-8s, all of which meet the standard, according to the company.

Deadline on the horizon

The confusion and uncertainty stems from FCC Rule 74.550, which went into effect in 1985 and required stations to use FCC-approved specification STLs under the type notification process within five

years, by July 1990. The intent was to prevent interference as more stations were being packed closer together.

Broadcasting equipment was not required to be FCC approved prior to 1985.

As the deadline creeps closer, many STL companies and station engineers said they are confused about the rule because of uncertainty about who is supposed to file the type notification and whether the older units could continue to be used after July 1990.

(continued on page 7)

"Emergency" in NJ

by Benn Kobb

Fort Lee NJ The fight over the future of FM radio in Bergen County, NJ, involving the use of a translator has taken a highly unusual twist.

Exasperated at broadcaster opposition to proposed local origination over translator W276AQ, the local governing board declared a "radio state of emergency" in Bergen County effective 6 September and filed the declaration with the FCC. The emergency status has no definite date of cancellation.

The action was in support of Gerard Turro, a broadcast engineer who operates the translator in Fort Lee and has

tried for years to obtain an FCC waiver to originate programming intended specifically for county residents.

Bergen is the most populous county in the US without a commercial FM station. Proximity to the congested New York City market virtually guarantees that no full-power commercial FM allocation will ever be made to the county.

Political support

The governor of New Jersey, congressmen, senators and other officials have announced support for the proposed operation. They cited numerous local emergencies that allegedly went un-

(continued on page 15)

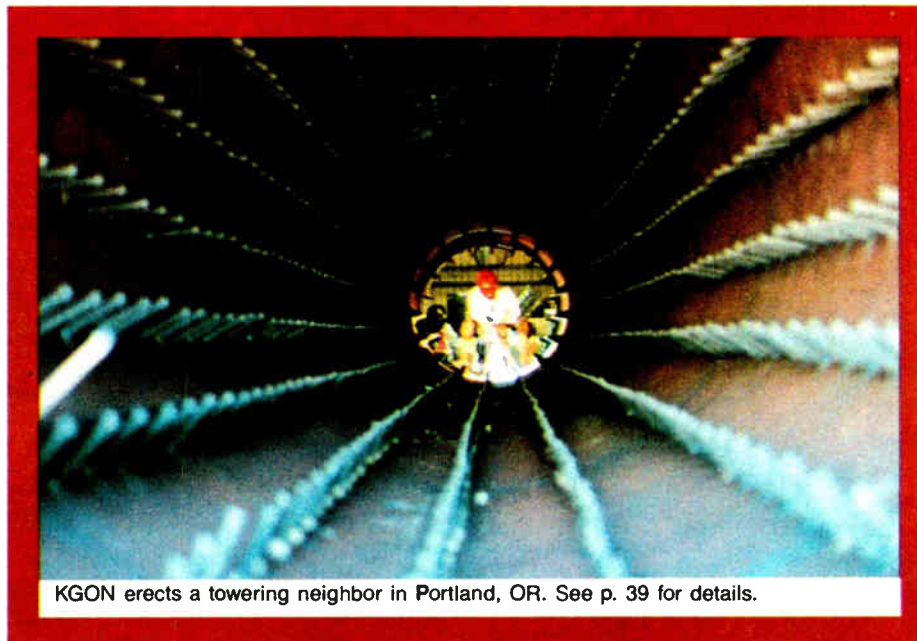

KGON erects a towering neighbor in Portland, OR. See p. 39 for details.

Radio Legislation to Have Its Day on Hill

by John Gatski

Washington DC The NAB is optimistic about radio-related legislation passing the 101st Congress, despite placement on Capitol Hill behind such high-profile bills as the resurrection of the Fairness Doctrine.

Although the principal radio bills may not pass before the fall recess, the NAB is "hopeful" they can get through Congress by next year, NAB Government Relations VP Jim May said.

NAB focuses on renewal bill

The NAB is focusing on the "Radio Renewal Bill," HR 1136, which would tighten up the licensing process to prevent abuses, and its companion bill that addresses AM, HR 2714. Among issues the AM bill raises is mandating AM stereo on receivers, allowing homesteading on the proposed expanded AM band and limiting the role of FM translators.

The radio bills have been overshadowed during much of the fall session by recent congressional attention on more visible broadcasting legislation, including the Fairness Doctrine, which passed the House in October, and children's programming bills.

May, however, said the progression of the radio bills seems to be on schedule.

The Radio Renewal Bill has 160 cosponsors and indicated support from House Telecommunications and Finance Subcommittee Chairman Rep. Edward Markey (D-MA), May said.

Minor objections

The NAB has received some receiver manufacturer objection to HR 2714 mandating AM stereo in radios equipped with FM stereo. "But it's nothing that can't be worked out," May said.

"I am most optimistic that we have an opportunity to move something on the

(continued on page 8)

Q. How Many DYNAMAX CTR10 Series cartridge machines are in use worldwide?

A. Over 7,000 units now are operating in 33 countries. And that's less than four years since introduction of the CTR10 Series.

Find out why the DYNAMAX CTR10 Series has proven #1 in popularity around the world. Contact your authorized Dealer or Fidelipac for more information.



Fidelipac Corporation □ P.O. Box 808, Moorestown, NJ 08057 □ U.S.A.
609-235-3900 □ FAX 609-235-7779 □ TELEX 710-897-0254
Dynamax is a registered trademark of Fidelipac Corporation.

NEWS BRIEFS

NPR Awarded Studio Grant

Washington DC National Public Radio (NPR) has been awarded a \$500,000 challenge grant by The Kresge Foundation, which will go toward construction of a state-of-the-art recording and production studio at NPR headquarters here.

The grant intends to provide incentive for donors to contribute to the construction project, NPR said. The organization must raise \$1.2 million by 1

January 1991 in order to receive the donation.

Construction on the studios is slated to begin in early 1991. They will include advanced audio services such as multitrack digital recording, digital editing and mastering and production.

"The planned new production facility will take us into the 21st century, enabling NPR to provide technological leadership to public radio and to enhance significantly the diversity and sound quality of program

services to our member stations and their listeners everywhere," said NPR President Doug Bennett.

FM Fined \$2000 for Indecency

Washington DC The new Commission continued a firm stand on its view of indecency by fining a Detroit FM \$2000 for airing an off-color song during a January 1988 morning show.

WLLZ-FM, which aired at 9 AM a recording of an off-color parody was given 30 days to demonstrate in writing why the fine should be upheld or reduced—or to pay it.

The 4 October ruling follows the 24 August citing of three ra-

dio stations—WFBQ-FM in Cincinnati, WLUP-AM in Chicago and KSJO in San Jose, CA—for alleged indecent broadcasts.

Those stations, however, were sent letters containing transcripts of the offending broadcasts and given 30 days to respond before a fine was imposed. The WLLZ incident marks the first time the FCC has held a station liable for alleged indecency without first sending an inquiry, the Commission said.

Forest Service Hikes Delayed

Washington DC A move by the US Forest Service to increase site fees for broadcast

antennas located on public land has been delayed for one year, following Congressional pressure.

When proposed late last year, the increase drew heavy criticism from members of the Senate and Congress, who asked for a delay in the hike in order to hold hearings and to consider legislation banning the increases for communications uses.

The NAB also objected, charging that while the Forest Service by law is required to set fees for the use of public land by fair market value, it instead is enacting fees based upon the fallacy that broadcasters have the money to spend.

NAB said the Forest Service should reconsider in view of the public service stations provide.

The year-long delay came about after a House-Senate conference committee added language to the 1990 Interior Appropriations bill that blocks the increase, set to take effect 1 January.

Under the amendment, the Forest Service must report to Congress by 1 March how the proposed fee increases would reflect fair market values for the tower sites.

New Station Totals Revealed

Washington DC An FCC report on broadcast station totals in the US shows a continued rise since the spring.

The number of domestic radio stations as of 30 September was 10,612, an increase of 66 since 30 May, 1989.

The number of AM stations was reported at 4965, with 4240 FMs. There were 1407 FM educational stations.

We Re-invented the Wheel AND IT'S SQUARE!

Naturally, with all of Wheatstone's experience at building and interfacing consoles, it was inevitable that we would take on the design and manufacture of suitable furniture for our audio installations. First we listened to engineers and their requests, then we went to work. The result is a significant improvement over previous designs.

Consider the advantages of double-sided equipment cabinets with fully interchangeable door panels, with each side able to accommodate 19 inches of rackmount equipment. Consider the convenience of hinged twin drop-down punchblock panels for easy installation and maintenance. Consider the advantage of hard chrome plated steel mounting rails that eliminate the stripping problems associated with lesser aluminum designs. Simply consider the strength we've achieved with full inch and a half thick side panels and hybrid inch and a half thick countertops.

We have re-invented cabinet technology. We've wedded the latest precision NC metal componentry to hybrid plywood high density, high resin pressure-laminated substrates. Our construction and bonding techniques have been optimized to eliminate stress related laminate problems. We've handled wire management: there are generous pathways between each enclosure, as well as an integral channel punchblock housing under the console counter to keep everything neat, concealed and away from unauthorized hands. And, since cabinet faces can accept either equipment or door panels, systems can easily be configured to fit virtually any room. Doors can even be placed on cabinets intended for future electronics installation.

This cabinetry is very clever, unbelievably strong, and (of course) square—precisely. It has that Wheatstone major market look. So contact Wheatstone for furniture, consoles, or prewires.

INDEX

Riding Out Hugo's Onslaught by Buddy Womack	24
Achieve Loudness with Quality by John "Q" Shepler	25
Radio at the Old Alma Mater by George Riggins	26
Deflating an Overblown Ego by Allan Roycroft	28
The End of an SCA Tradition by Tim McCartney	29
Techniques for Stereo Miking by Bruce Bartlett	33
RTNDA Brings Hope For Improved Gear by Phillip O. Keirstead	35
FCC Deluges Station With Stiff Penalties by Harold Hallikainen	36
A Wish List for Workstations by Mel Lambert	37
KGON Readies New Tower by Dee McVicker	39
Interruptible Feedback Primer by Andrew Ellis	41
Life Support for Transmitters by David Hebert	46

Wheatstone Corporation

6720 V.I.P. Parkway, Syracuse, NY 13211

TEL 315-455-7740 FAX 315-454-8104

NAB Calls for Revisions to EBS

by Alan Carter

Washington DC The NAB has called on the FCC to consider revisions to the Emergency Broadcasting System (EBS), including a rulemaking to relax monitoring and remote control requirements.

Among other suggestions in the NAB petition are a shorter EBS attention signal and revision of the test script to allow for localization.

The NAB noted that the FCC clarified the rules pertaining to remote control in September 1989, still requiring that a station staff member monitor the EBS receiver itself and have the capability to activate the EBS encoder immediately and to promptly broadcast EBS test and emergency action announcements.

But with telecommunication technology available today, NAB said it believed "greater technological flexibility" could be given to stations.

"Stations should be allowed to monitor, activate and fully control EBS operations by remote control, without the requirement that EBS equipment be present at the distant control point," NAB stated. "Easily available technology can notify any designed member of a station's staff, wherever he or she might be located and provide for immediate EBS monitoring and control."

On the issue of the attention signal, NAB suggested that the 20-second mini-

imum be reduced to eight seconds and that the 25-second maximum be retained. "Many listeners and viewers become annoyed and may either tune to another station or turn the radio or TV off," NAB argued. "A shorter EBS tone would serve the public interest by minimizing such 'tune out.'"

NAB praised a waiver granted the Michigan Association of Broadcasters for a six-month field test on a shortened tone effective 1 October.

A final revision NAB called for was to allow broadcasters to tailor test scripts to local areas rather than using a standardized script. A station could announce the

availability of air raid shelters, Red Cross centers or hospitals.

"With a variety of test announcements, the station could use the opportunity of the EBS test to impart useful, community-oriented information," NAB stated.

For information from NAB, contact Science & Technology at 202-429-5346.

RAC Studies Nighttime Contours

by Charles Taylor

Washington DC The working party of the FCC Radio Advisory Committee technical subgroup is continuing its efforts to work up a way to deal with adjacent channel nighttime contour calculations using the newly proposed 25% exclusion criterion for AM stations.

The FCC has supported using the 25% method to calculate RSS, but is considering the use of a single RSS that would take into account both co- and adjacent channel signals.

At a meeting of the subgroup 3 October, members raised the question of whether to have separate calculations for co- and adjacent channels, which again generated most of the discussion.

Previously, the group discussed several alternatives, but a paper produced by the working party criticized

the burden of using three separate numbers for calculations should separate criteria be selected.

Concern also was raised that in depicting a station's coverage area, if a value other than the lowest one of the three were used, it might pave the way for raising any lower RSS calculation to the higher one, increasing the potential for interference.

At its most recent meeting, the group maintained concern about using three different values and after discussion, basically decided that it should be concerned with one RSS including the adjacent channel limit.

Said Wally Johnson, subgroup chairman, "We agreed to protect the greatest of the following: the normally protected

contour for the class station; the co-channel or the co-channel RSS using the 25% exclusion method; or the 2 mV/m contour."

This, he added, would permit movement on adjacent channels depending on what the RSS of the station is.

The modified proposal was to be considered for group approval at a follow-up meeting 25 October. If given the nod, the conclusions will be presented to the full FCC Radio Advisory Committee later this month.

Johnson said he hoped a decision on the issue would be in final form to present at an FCC *en banc* meeting scheduled 16 November to discuss the future of AM.

For more information, contact Wally Johnson at 703-824-5660.



A Pair of Powerful Processors

Bradley presents the processors for the 90's; Yamaha's SPX-1000 and SPX-900. Professional specifications and great new effects programs make these a potent pair of processing "Swiss Army Knives". The sophisticated digital reverberation and effects systems provide dozens of preset programs including natural reverberation and early reflections, delay and echo, pitch change and more.

Multiple effects programs allow the SPX processors to provide up to 5 processes simultaneously. With a sampling frequency of 44.1 kHz and full frequency response from 20 Hz to 20 kHz, the SPX duo have exceptionally clean, transparent sound.

Call or fax your Bradley professional toll-free today for more information and a quotation.



**BRADLEY
BROADCAST
SALES**

8101 Cessna Avenue
Gaithersburg, Maryland 20879-4177

800-732-7665 / 301-948-0650
Fax: 301-330-7198

Where Service and Engineering Make The Difference

Stop worrying about strange noises & things that go bump.



ST-90
SPUCE TRAK:
\$1050.*

Start prepping carts the *right* way. Get worry-free deep erasure and splice detection with any NAB standard cart. No more noises lurking on improperly erased tape. No more thumps left by bulk erasers. No more bumps from mislocated tape splices. Just perfect carts every time, with our new ST-90 Splice Trak.

- Handles tape smoothly and safely at a fast 27 1/2 ips.
- Dual heads erase to a depth of 85 dB.
- Same reliable Phase Lok V head block, long-life low-voltage solenoid and positive cart guidance system as used in BE cart machines.

What you get out of your cart machines depends on what you put into them. Call us at (217) 224-9600 or ask your Broadcast Electronics distributor for info on the advanced ST-90 Splice Trak cart preparation system.

* F.O.B. Quincy, IL. Exclusive of sales or use tax.

**BE BROADCAST
ELECTRONICS INC**

4100 North 24th Street • P.O. Box 3606 • Quincy, IL 62305
Tel: (217) 224-9600 • Fax: (217) 224-9607 • Tlx: 250142

Rising to the Task, Post-Quake

by Judith Gross

Falls Church VA I was expecting the last few innings of the **World Series**, Game 3 and boy, was I ever surprised.

We just get over telling you about our friends down in **South Carolina** and there it is, coast to coast coverage of the kind of event that reminds us we're at the mercy of the forces of nature in spite of it all.

Our friends in **San Francisco** radio seem to have pulled things together as quickly as possible to get back on air with **emergency generators**.

And the **local stations**—TV as well as radio—did a first rate job of **going national** to tell the rest of us what was going on, post-quake.

And once again we have to wonder where we'd be without modern electronic communications to **pull us all together** through the crises.

Not to mention the **human link** it provides. Who didn't shed a tear when they pulled that brave survivor off the wreck of the bridge?

Up in **Noo Yawk** for the **AES** show, talk on the airwaves after the quake was whether or not to cancel the rest of the baseball games. Sports-minded **WFAN** fans said "play ball" but some network announcers on the scene of the disaster weren't so sure.

I've been known to think that there's very little in life that is more important than **baseball** and even *I'm* not so sure. But I enjoyed the **radio debate**.

☆☆☆

Hope there isn't too much of a debate when **AM's problems** come to the forefront at the **FCC** next week. Most of us seem to know that **something** has to be done.

It'll be interesting to see **who shows up** to make their feelings known. I'm talking about the so-called *en banc* meeting, a fancy way of saying "yer all invited."

Nobody's taken me up on my idea to solve the **stereo problem** with a mandatory stereo requirement yet. But hey, I'm patient, I'll wait ...

It's really intriguing how **Gerry Turro** got the **Bergen County, NJ**, Freeholders to jump into the translator fray by declaring a **state of emergency** so he could keep originating locally. (See story, this issue.)

Growing up in the Big Apple, we just kind of took it for granted that **Joisey** was already in a perpetual state of **emergency**. (I make an exception for you, Moonachie.)

But with all the other natural disasters, it's not out of the question that **Turro has a point**. Hard to imagine the metropolitan New York stations making much of damage to Bergen County if the same type of thing that hit Frisco happened, oh let's say at **Times Square**.



Some afterthoughts on the **SBE convention** ... The Ennes workshops were a successful effort and those who attended told me **they learned a lot**, especially from the companies who decided against using the time as one long commercial for their products ...

Exhibitors and attendees both relished the chance to spend some **quality time** asking and answering questions. The **vendors** got a chance to learn more about their market and the **CEs** got a chance to get meaningful explanations about design considerations and equipment performance ...

I finally learned that **Kansas City nightlife** has moved out to the

suburbs—*now* you tell me ...

New SBE prez **Brad Dick** told members that the city had arranged for a special **Haunted House**, staffed, of course, by **GMs and PDs**.

Now look at the sign promising "**Nightmares**" and tell me if that looks like the kind of place you'd see either one (maybe the engineering shop) ...



Special attraction at the SBE convention ...

And wait a minute. Who was this **Fred P. Otts Bar & Grill** placing ads in the SBE show daily? And why were they telling folks in their ads to come to **their place instead of the convention?** (Page 5, Saturday.)

☆☆☆

Finally had a chance to catch up on my mail and think of **all those trees**

which went into the making of all that paper!

From **Dave Burns**, at Allied, who serves on the NAB's Exhibitor Advisory Committee comes word of **two vacant seats** on the committee.

How about a little **grass roots** effort here? Any exhibitor want to run or nominate someone to represent him/her?

The committee meets four times a year, usually at shows, and is looking for a representative from an **NAB spring exhibitor** with a booth of 400 square feet or less and one from a large audio company with a booth of 1601 square feet or greater. Let Dave know (317-962-8596) or tell us and we'll pass it along.

Some of you have been sending along some pretty nifty ideas lately. How about a **processing survey**? Not so much what do you use or how high do you modulate, but do you feel it **helps or hurts** your station's ratings? (And can you back that up?)

Another one I liked: We've had enough on-air-personality-of-the-year, station-of-the-year, endless-talker-on-a-major-network-of-the-year and so on. How 'bout an **engineer of the year**?

We could stage a **glitzy ceremony** hosted by the SBE and break it down into categories according to **engineering budgets**, from corporate-group-owned-with-five-year-upgrades to holding-it-all-together-with-a-lump-of-solder-and-a-prayer smaller market operations.

We'll call it the **Bronze Beeper Awards** and make it a black-tie and formal gown award ceremony, and then we can all put on our **SBE shop coats** over the tuxes and such. Send your entries in and we'll see what we can get going here.

■■■

Heard something interesting? Spill your guts to **Earwaves**. Write PO Box 1214, Falls Church VA 22041, or call me at 703-998-7600. Best tidbit of the month wins a coveted 1989 edition **Radio World** mug.

Remote Control You Can See and Hear

Want to know what's happening at your transmitter all the time? There's no better way than the **ARC-16 Remote Control System** from **Burk Technology**.

When something happens, your studio operator will know instantly. You can take prompt corrective action, observing the results on the front panel display. Alarms, meter readings and status are displayed in clear text, with labels you define.

When you're away from the station, let the **ARC-16** call you. The **DSU** option will dial up to nine numbers, announcing readings and alarm conditions. You enter commands from your **Touch-Tone®** phone, then listen to the highly intelligible digitized voice.

Need to control two transmitter sites? No problem with the **ARC-16 Multi-Site** option. Connect up to three **ARC-16's** for simple, unified control of your entire operation. All units in the system can be used as control terminals for the other sites.

Imagine switching the studio audio processor from the transmitter or resetting the automation by telephone. The **Studio I/O** option puts control of studio equipment at your fingertips even when you're not there. **EBS** equipment, tape decks, security systems and **STL** transmitters are just a few of the many possibilities.

Break away from telephone lines with subcarrier generators available at no extra charge.

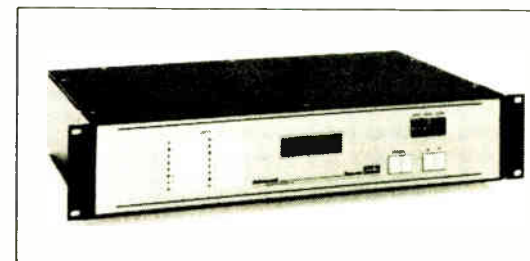

ARC-16 Remote Control System

Burk Technology is finding solutions to today's remote control challenges. Our systems are built to last and are backed by a 2-year warranty.

Want to know more? Call us **TOLL FREE** at 1-800-255-8090. We'll help you find the best remote control solution.

Burk Technology, Inc.
7 Lomar Drive
Pepperell, MA 01463
(508) 433-8877

BURK
TECHNOLOGY

Circle 48 On Reader Service Card
World Radio History

formerly

Advanced Micro-Dynamics

READERS FORUM

Send comments to: Readers' Forum, Radio World, Box 1214, Falls Church VA 22041 or MCI Mailbox #302-7776; or call 800-336-3045.

More praise for Hunn

Dear RW:

I am surprised there is not more interest in Mr. Peter Hunn's proposal of "Low power FM for struggling daytime AM stations" (22 March RW). I have talked with Mr. Hunn on one or more occasions and feel he is the type of radio entrepreneur who is in radio because he loves radio and wants to provide a service to the community of license.

In most cases, a minimum Class A (100 watts at 100 feet) would work adequately. Some places could possibly get as much as a kilowatt or more. However, current FCC rules for commercial FM stations would have to be changed to go on contours, like the educational FM stations, in order to permit this type of operation.

I feel a 1 mV/m signal over the city of license would be adequate in most cases, since you are not trying to penetrate high-rise steel and concrete structures. This would require an FCC rule change from the current 3.16 mV/m contour over the city of license required for commercial FM stations.

The 1 mV/m for a minimum power Class A would go out 3.8 miles, which would adequately cover most small communities with a population of 4000 to 8000.

As for cost, Mr. Hunn is correct in the fact that this could be done fairly inexpensively. Some of the new exciters have a TPO of 50 to 60 watts. Also, there are a number of the older 250 watt and 1 kW rigs out there that could be picked up on

the used market quite easily and adapted for this type of service, using one or two bays of circular antenna, to provide a low power Class A service.

What would be gained is the ability to cover the community's activities which occur after sunset, although admittedly, in most cases it would not be practical for these stations to try to operate 24 hours a day.

I could see (the stations) remaining on until 11:00 PM or midnight, in order to cover local elections, local high school sports, town meetings, moonlight madness sales, etc. There is also the advantage of being on the air pre-sunrise with school closings, weather information and farm reports.

It's a great idea and I would like to see the NAB and other radio organizations give Mr. Hunn's idea some serious consideration. Possibly this is the solution for solving part of the AM dilemma.

Again keep up the good work. It's great to have a technical publication which is strictly devoted to radio.

Thomas F. Nornhold,
broadcast engineer
T.N. Communications
Kettering, OH

Dummy load repair

Dear RW:

We read with interest Charles Taylor's article on WAEB's multipath testing in your 23 August 1989 issue.

The reference to repairing the Electro Impulse Lab., Inc., water cooled dummy load has prompted this letter; we have also contacted WAEB and are arranging factory service of the equipment.

We would like to point out that this type of load system uses coaxial water loads which are supplied to us by the leading manufacturers in the field. They are easily field repaired so long as the right parts, tools and instructions are used.

Electro Impulse Lab, Inc. manufactures equipment that has a proven record of quality and reliability which is attested to by the hundreds of units now providing satisfactory service worldwide.

Mark Rubin, President
Electro-Impulse Lab., Inc.
Red Bank, NJ

Early superpower FM

Dear RW:

In the little known superpower FM sweepstakes I nominate KSBK. Its studios were located in the back of a factory in San Bruno, CA, the city of license.

The transmitter was located on Mt. Diablo at an elevation of 3580', with a 285' tower. Height above average terrain must have been close to 3000'.

A 10 kW transmitter was used to drive a 50 kW composite amplifier. This amplifier was remarkable because it was built into a single rack. ERP was about 500,000 watts.

With a prevailing inversion layer over the California central valley creating ducting conditions, most days KSBK could be heard from one end of the valley to the other—a distance of almost 400 miles. KSBK also covered the 11 San Francisco

The plan to gather together all concerned parties for an *en banc* meeting on AM's future is a good first effort from the new FCC.

The past few years has spawned abundant debate and numerous studies and ideas on what can be done to help AM thrive again.

While some of these efforts—such as the NRSC standard—have proven fruitful, too many of the ideas for AM improvement have come from viewpoints specific to a particular group or interest.

Too often broadcasters try to tackle the issues facing AM by appealing only to other broadcasters—the equivalent of "preaching to the converted."

On the other hand, there have been issues such as AM stereo, which has mired

AM broadcasters in an endless debate and has caused industry organizations and interests to skirt the issue for fear of litigation.

One benefit of an *en banc* meeting is that it is open to all parties.

At the upcoming meeting receiver manufacturers, station owners, programmers, engineers, members of trade associations and even the public will be able to offer input on what can be done to help AM.

Targeting AM's Ills Together

For perhaps the first time, these groups will have the chance to hear each others' concerns and communicate to the Commission how important it is to develop a plan to ensure AM's future.

Those participating will also have an opportunity to consider the interrelationship that exists between technical and non-technical issues facing AM and to form strategies based on mutual goals.

All who are concerned about AM should take this chance to put forth ideas either in person at the meeting or through written comments.

While it will take more than a single FCC meeting to tackle AM's remaining problems in a practical way, a meeting of the minds about AM's future is a good way to start.

At the very least, it will get everybody talking the same language. —RW

Bay area counties.

KSBK went on the air in 1948 and went off about 1951. Its 50 kW amplifier was used for only about six months. The rest of the time the 10 kW driver was connected to the antenna.

KSBK was not built by broadcasters. No real effort was made to operate it as a commercial station. It was built to showcase the products of its owners. The name on the door of that factory in San Bruno was Eitel-MacCollough, makers of Eimac power grid tubes.

Fred Krock, Engineering Supervisor
KQED-FM
San Francisco, CA

Investing in quality

Dear RW:

The radio program industry is populated by some persons who might charitably be described as "gold-chain wearing bottom feeders" who care more for glitz and glitter rather than good business.

This preoccupation with glitz has led to homogenized, over-processed high calorie programs which sound disgustingly similar in all markets. Now, they're working their "magic" on the FM signal, making it all but unlistenable.

To me, this resembles the tale of the farmer who takes the axe to the golden goose because the goose isn't producing golden eggs at a rate consistent with the desires of the farmer.

While stations who carry homogenized, over-processed high calorie programs may maximize short term revenue, the long term prognosis is anything but rosy. Managers employing such short-term fixes have forgotten about long-term investment.

If this trend continues, then the radio business will become as troubled and stagnant as the railroad industry.

Fortunately, there are some broadcasters who can see the forest for the trees; they're investing for the long term. Their stations provide programs that are innovative,

creative and useful without resorting to cookie-cutter copies of certain formulae.

These stations are service oriented; they help their advertising clients solve problems and their programs serve the public interest, convenience and necessity (with no sacrifice in audience and popularity. Their stations meet (or exceed) generally accepted engineering standards; their signals are clean, clear and robust.

To help encourage such stations, the kind who invest in their people and their plant, I will offer, effective 1 January 1990, a 15% discount off the price of any Motor Sports Radio program to any AM station broadcasting with AM stereo.

I will also offer a 5% discount to stations using a single line frequency extender (250 Hz) shift, in addition to any other discount the station may qualify for. Those stations who have invested in such equipment deserve the opportunity to recoup their investment more quickly.

I believe that other programmers should recognize and encourage such investment. That discount represents my investment in the continued health of the radio industry.

In my years of covering auto racing, I've seen many winning teams. Those winning teams, like good radio stations, have much in common.

Winners do the right things, not the expedient things. Winners are consistent and creative. Winners treat their equipment, and those who operate that equipment, with respect.

When things go wrong, winners fix them right—the first time. Winners solve problems with sound solutions; they invest—they don't speculate. Winners are persistent; they don't give up. Winners are judged on their accomplishments; those who aren't are judged on style.

I'll ask a final question: Are you content to run with the pack or are you willing to do what it takes to be a winner?

Paul Kaminski, CEO
Sportcom Associates
Johnson City, NY

Radio World
Vol 13, No 21 November 8, 1989

Editor, Judith Gross

Associate Editor, Alex Zavistovich
Buyers Guide Editor, Richard Farrell
News Editor, Alan Carter
Charles Taylor, John Gatski
Benn Kobb, Frank Beacham/L.A.
Technical Advisor, Tom McGinley

Production Director, Judith Chamberlain
Production Manager, Jeanne Pearson
Kim Lowe, James Gillgam,
Bill Spencer

Publisher, Stevan B. Dana
Associate Publisher, Arthur Constantine
Ad Coordination Manager, Simone Leaser
Robyn Rosenthal

Circulation Manager, Tiana Hickman
Accounts Receivable, Caroline Freeland

Advertising Sales Representatives:

East/Midwest, Art Constantine
800-336-3045, Fax: 703-998-2966
West Coast, Pat Macsata
415-786-2198, Fax: 415-786-2754



Radio World (ISSN: 0274-8541) is published semimonthly by Industrial Marketing Advisory Services, Inc., 5827 Columbus Pike, Suite 310, Falls Church, VA 22041. Phone: 703-998-7600, Fax: 703-998-2966. Second-class postage rates is paid at Falls Church VA 22041 and additional mailing offices. POSTMASTER: Send 3579 forms and address changes to Radio World, P.O. Box 1214, Falls Church VA 22041. Copyright 1989 by Industrial Marketing Advisory Services, Inc. All rights reserved.

Free subscriptions are available to professional broadcasting and audiovisual equipment users. For address changes, send current and new address to RW a month in advance of the above address. Unsolicited manuscripts are welcomed for review; send to the attention of the appropriate editor.

Next Issue RW
Nov. 22, 1989

Industry Standards

OTARI

From the B11 to the full-featured MX-55 and the amazingly affordable MX-50, Otari two-tracks have become industry standards. The MX-50 shows a few of the reasons why:

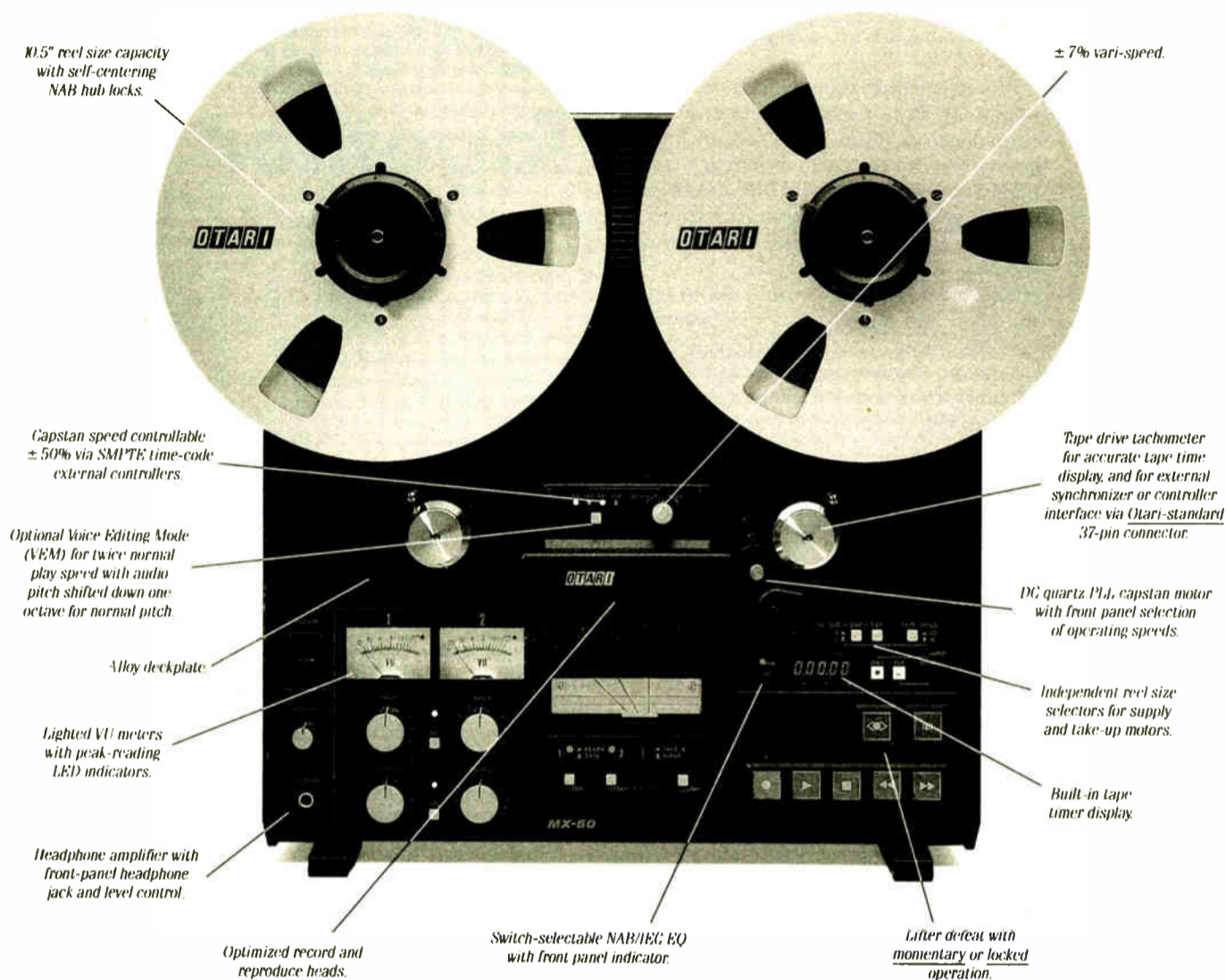

ALLIED

Allied sets the industry standards for customer service and support, with innovative programs like these:

- Two Authorized Service Centers
- Used Equipment Exchange
- Systems planning, design, installation
- Satellite information and equipment
- Fully trained and knowledgeable sales people

You set high standards for yourself — count on Allied and Otari to help you meet them.

Call 800-622-0022
IN CANADA CALL 800-268-6817

ALLIED
BROADCAST EQUIPMENT
A HARRIS COMPANY

STL Firms Respond to FCC Rule

(continued from page 1)

According to the FCC, either a manufacturer or a station must apply for type notification, which requires filing of FCC Form 731, a statement certifying compliance (which must be supported by performance tests) and a \$100 processing fee.

Easier if companies do it

Type notification is easier on the station and the FCC if the manufacturer undertakes the type-notification process, according to FCC Staff Engineer Hank Van Deursen.

He said if a manufacturer does it, ev-

MHz band, the most commonly used band for aural broadcasters.

McNally said the the FCC technical standards for STLs have been in effect for many years, but the Commission did not require the type notification.

According to Moseley Sales Manager Dave Chancey, most of the popular Model PCL-505s can be type notified because they meet those specifications.

He said recent retesting of the PCL-505 has concluded that "75%" of the 2000 units sold will meet the FCC specification.

Moseley said the company will undertake the notification process for those

engineers were not certain if any of them could meet the frequency tolerance limit.

The uncertainty was the result of the FCC not listing the .005 frequency tolerance in the rule until July, Chancey said.

Although stations using PCL-505s can now breathe a sigh of relief, the scenario is less optimistic for stations using pre-1978 PCL-505s and the much older 401s, 303s and 101s.

According to STL companies, scores of old STLs, some 25 years or older, are still in service or in the backup mode and probably will not meet the standard without modification.

Modification too costly

Chancey said pre-1978 versions of Model 505 may require modification to meet the specifications, while the much older Model 401s, 101s and 303s still in operation probably cannot be modified at all cost effectively.

Chancey said Moseley is leaning toward not offering an upgrade for those older models.

"Is it worth it to us to get our suppliers to start building those old PC boards (for those models in order to make an upgrade)?" he asked.

Contract engineer Brian Roth of Oklahoma City, OK, said he is glad that Moseley will type notify most of its Model 505s since there are so many sta-

TFT Sales Manager Eric Lane said tests are being conducted on Models 7700, 7700A, 7700B, 8300 and the 8600, which were made in 1985 or earlier, to see how close they are to FCC specifications.

"There may be some products to which we can make economically feasible upgrades," he said.

TFT may upgrade

Because testing on those STLs is still ongoing, Lane was unsure which ones could be upgraded.

Like Moseley, he said certain models
(continued on page 8)



Most of the Moseley PCL 505 STLs will stand up to the FCC's standards.

ery unit of that model sold automatically will be type notified, which would eliminate a monumental record-keeping task for the FCC if every station had to certify its own equipment.

If a station undertakes it, the type notification only applies to that licensee's STL, he added.

Van Deursen said no extension of the type notification deadline is currently contemplated and if a station is discovered operating an unapproved unit that could cause interference after 1 July 1990, they will be given a citation.

FCC Engineering Policy Branch Chief Jim McNally said most transmitters and STLs made since 1985 already are approved under or can easily can meet the specifications through the type notification process.

To be approved, a unit must meet acceptable spurious emission levels and a .005 frequency tolerance for the 944-952

PCL-505s that meet the FCC specifications without modification, Chancey emphasized.

PCL-505 users can relax

Over the summer, several station engineers said they had been told that Moseley would not type notify any of

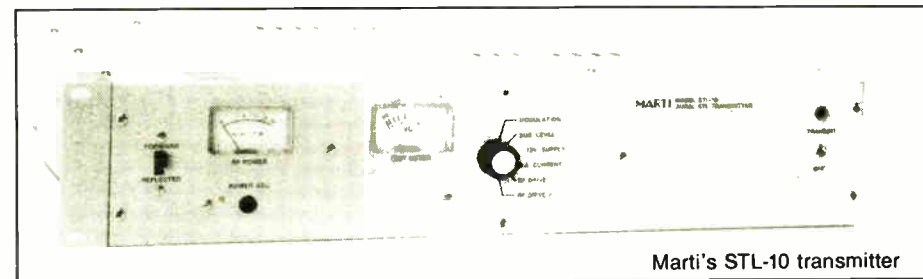

Marti's STL-10 transmitter

the PCL-505s.

Chancey said the company initially leaned toward not pursuing type notification for PCL-505s because factory en-

gineers were not certain if any of them

"My concern was that the rule could be a deathblow to those people," Roth said.

Use Your 1989 Radio World Annual to find:

- Top Ten News Stories of 1988
- Earwaves
- Convention Reviews
- FCC Phone Listing
- NAB Phone Listing
- Industry Perspectives
- Product Source Book
- Supplier Source Book
- Company Profiles
- R/W Author Index
- R/W Subject Index
- Buyers Guide Reprints

Don't have yours ?
Get One Fast!
Send \$14.95 for each Annual to:

1989 R/W Annual
P.O. Box 1214
Falls Church, VA 22041

Your Problem Solvers

from **ATI**



- Mike
- Line
- Phono
- Mixing
- Matching
- Metering
- Monitoring
- Processing
- Distribution
- Rack Mounting

AUDIO TECHNOLOGIES, INC.

328 W. Maple Ave., Horsham, PA 19044 • (215) 443-0330 • FAX (215) 443-0394



STLs Reviewed for Compliance

(continued from page 7)

may require considerable modification and money to upgrade them to FCC specifications.

However, he said TFT will do all it can because "there is still a lot of good equipment out there."

Marti President Mac McClanahan said

The cost of a new STL ranges from \$6000-\$12,000.

Van Deursen said that if a factory chooses not to make upgrades available for an old STL and a station cannot afford to replace it with a new one, maybe an independent shop can fill in the void.

"An independent could offer a service

about 1985 rule.

"Probably nobody took it seriously when we did it," Van Deursen said. "They say, 'I'll worry about it next year.'"

Unclear ruling

Chancey maintained the rule is confusing because the Commission has not been clear.

For example, Chancey said it does not address how the company will get FCC approval stickers out to the stations with old STLs, especially for those units that have been resold several times.

Moseley is unsure whether units will have to be brought back to the factory or some type of sticker could be mailed out to stations that are known to have the units, Chancey said.

McNally said the Commission has decided to issue the grant of notification to the manufacturer and let them provide proof of compliance to the stations.

He said the Commission wants to provide proof of certification without requiring companies to issue a burdensome recall in order to affix approval stickers.

The FCC may allow stations to write to the manufacturers to get a photo copy of the FCC grant of notification for their STL or allow companies to issue approval stickers to the licensee.

McNally suggested that stations write to the STL companies to see if their models are going to be type notified and to find out what proof of compliance is needed.

Stations can also find out if a type notifiable STL can be modified to meet the specifications, he added.

For information about STLs and type notification, contact Dave Chancey at Moseley Associates, 805-968-9621; Jim McNally at the FCC, 202-632-9660; Hank Van Deursen at the FCC, 202-632-9660; Eric Lane of TFT, 408-727-7272; J-Square Technical Services President Jim Jones at 801-298-8515, and Mac McClanahan of Marti, 817-645-9163.

"There may be some products to which we can make economically feasible upgrades."

some of the STL-8s date back to 1970, but they met the FCC specifications.

He said of the 2000 to 3000 produced probably half are still in service. The company still produces the STL-10, which came on the market in 1980, McClanahan said.

New purchases inevitable

Although stations may consider modifying older STLs to meet the FCC rule, some stations should consider buying a new one if they are operating with a 20 year or older STL, McNally said.

Although STLs are not cheap, "It's like when you finally need to get a new car, you have to simply scrape the money together," McNally said. "Nothing lasts forever."

to the industry" by upgrading those STLs, he said.

J-Square Technical Services in West Bountiful, UT, repairs STLs. Owner Jim Jones said he currently is evaluating the feasibility of upgrading STLs to meet FCC specifications.

"I'm working on that now," Jones said. "I don't know if it is going to be cost effective."

In order to be cost effective for a station, Jones estimated that an upgrade should not cost more than \$2000.

Jones said for his test equipment to do the work it will cost him about \$45,000.

In addressing the confusion and concern the type notification rule has generated, Van Deursen said the companies and stations probably forgot

Congress to Act Soon on Radio Bills

(continued from page 1)

House side," he said in assessing the legislation's chances.

May noted that the success of a committee hearing scheduled 26 October, postponed from an earlier date, will have an impact on the legislation's future.

Similar legislation in the Senate will most likely depend on how well the bills do on the House side, he added.

"It's also clear that there are no guarantees in this," May cautioned.

For information about radio legislation, contact Jim May at the NAB, 202-429-5301 or the House Telecommunications and Finance Committee at 202-226-2424.

It's Not Just A Phase We're Going Through.

The tremendous success of the Tannoy PBM series of reference monitors is by no means coincidental. Since the introduction of the world renowned NFM-8 nearfield monitor, much time and effort has been spent on discerning the needs of the mixing engineer and the applied requirements of "playback monitors". The PBM Line exemplifies this commitment to excellence in reference studio monitoring. These compact loudspeakers sport robust poly cone mid-bass transducers utilizing efficient long-throw, high power voice coils. The low frequencies are carefully controlled by optimally tuned ports located on the rear of the loudspeakers. Hi frequencies are provided by Hi Power ferro fluid cooled polyamide dome tweeters which extend H.F. bandwidth beyond 20KHZ. The driver accompaniment is knitted

together by means of a precision hardwired crossover unit, utilizing robust low loss components, and heavy-duty input terminals which will accept standard 3/4" spaced banana plugs and the majority of high quality, specialist audio cables. Transducers and crossover assemblies are neatly housed in a stylish, high density, partial wrap cabinet, specially designed to minimize unwanted cabinet resonance, and high frequency reflection. In summarizing, we have left the best feature of all for last "price versus performance."

TANNOY
Professional Products



TEC AWARD WINNER

TANNOY

Tannoy North America, Inc. 300 Gage Ave., Unit 1, Kitchener, Ont., Canada, N2M 2C8
Telephone (519) 745-1158 Telex 069-55328 Fax (519) 745-2364

Circle 31 On Reader Service Card

It's the sound that makes people listen...

**I B R I L L I A N T
I O P E N
I N A T U R A L**

...and loud with no audio fatigue.

These are the qualities that make the VIGILANTE Multiband Limiter from CUTTING EDGE TECHNOLOGIES

the processor of choice for the hottest stations in New York, Los Angeles, Philadelphia, Baltimore, and Cleveland...just to name a few.

Beat Listener Fatigue

The VIGILANTE'S unique clipper/filter circuitry utilizes distortion eliminating techniques that allow you to control the loudness versus quality tradeoff. The VIGILANTE uses a combination of multiband high frequency limiting and user-controlled threshold levels, giving you the power to limit the shrill of a crashing cymbal without losing the clarity, brightness, or impact of mid-range vocals.

**Don't get left behind.
216-241-EDGE**

FAX: 216-621-2801

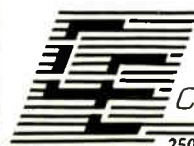

CUTTING EDGE TECHNOLOGIES, INC.

2501 West Third St. Cleveland, Ohio 44113

Circle 2 On Reader Service Card

This is one reason we sell more cart machines than anyone else.

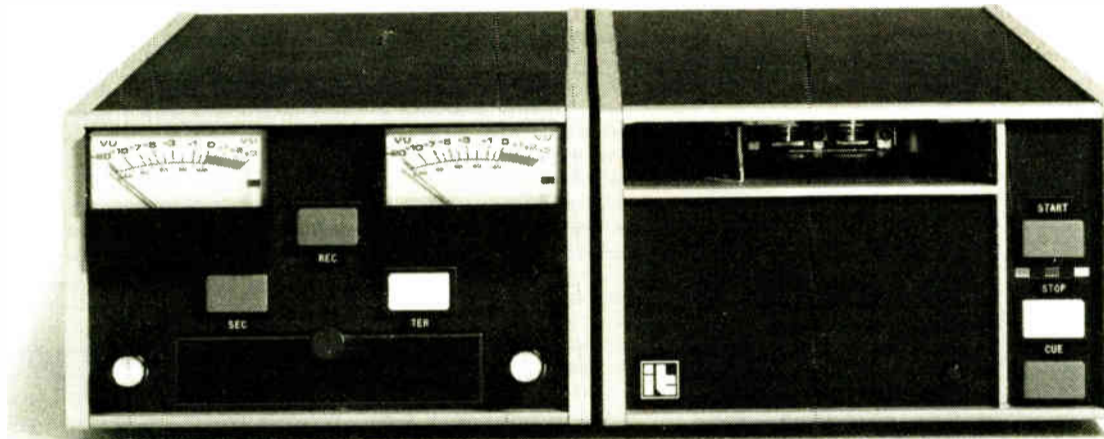

The 99B series Master Recorder features a patented erase, splice-locate and azimuth-adjust system (ELSA).

And here are three more.

Our Authorized 3M Dealers

Allied Broadcast
Equipment
800/622-0022

Broadcast
Services Company
919/934-6869

Broadcast
Supply West
800/426-8434

3M International Tapetronics — The World Leader In Cart Machines.

3M

More Samples And Bits For The Buck.



CD Player Excellence From Technics

The SL-P999 CD Player from Technics is truly a marvel of audio excellence. 20-Bit signal processing and 8 Times oversampling assure outstanding signal fidelity. 4-Digital to Analog Converters (2 per channel) help achieve exceptional sonic clarity. Specially selected parts such as fast-recovery diodes and high capacity electrolytic capacitors help minimize distortion.

For the broadcaster, the SL-P999 incorporates the cue-to-music feature. Simply select the cut you desire and the SL-P999 will automatically cue to the first sign of audio. In addition, a cue wheel is provided for manual cueing/search in 0.2 second increments.

For under \$500.00 you can own this outstanding CD Player. Call us toll free to order yours.

BSW[®]

BROADCAST SUPPLY WEST

America's Full-Time Broadcast Supplier

1-800-426-8434

ORDERS • INFORMATION • SPECIFICATIONS
BSW • 7012 27th Street W • Tacoma, WA 98466 • FAX 206-565-8114

Circle 14 On Reader Service Card

Resolution Sought in Kahn AM Patent Suit

by Alan Carter

Chicago IL Motorola asked a federal court here to expedite a ruling on its request that the court resolve the ongoing patent infringement claims by Hazeltine Research and Leonard Kahn against Motorola's AM stereo system.

Motorola said in a request for summary judgment that its AM stereo system does not contain the circuitry Hazeltine and Kahn claim, and that Kahn signed over his interest in his patent to Kahn Research, a point Kahn disputes. The action was filed 28 September in the US District Court for the Northern District of Illinois Eastern Division.

The dispute came to court in April 1988 when Kahn filed a patent infringement suit against General Motors. GM uses Motorola integrated circuits in its AM stereo car radios. Motorola filed a counter suit in Chicago asking the court to resolve the debate.

The New York court stopped proceedings pending settlement of the Chicago case. However, Kahn appealed the decision, which is before a federal appeals

court in Washington, DC.

In Motorola's recent filing in Chicago, the company also claimed Hazeltine and Kahn caused it to believe they had given up filing patent suits and argued that too much time has passed since original complaints voiced in letter form by Kahn in 1984.

Motorola said in court papers that three years ago Hazeltine Research stated that the potential award was too small to fight over. But with an expanded AM stereo business and circuit sales having increased from 2000 samples in 1983 to more than 15 million units by April 1988, Motorola suggested a suit now looks more lucrative.

"Kahn has deliberately chosen to wait an unreasonable length of time to file suit," Motorola wrote. "This court should not permit defendants even the opportunity to reap a windfall as a result of their inequitable conduct."

Motorola also argued that it further developed the AM stereo circuitry, without design changes under the belief that Kahn and Hazeltine had abandoned their claims.

Voluntary Layoff Order Put Forward at Motorola

by Charles Taylor

Schaumburg IL A voluntary layoff order that intends to reduce the workforce of Motorola Inc., by 2500 apparently will not affect engineers working on AM stereo, according to a company spokesman.

The early October decree will offer em-

ployees within specific divisions "enhanced severance benefits," including two weeks pay for every year of employment and medical benefits through the time covered by severance pay.

"We are actually looking to reduce head count," said Motorola spokesman Chuck Sengstock. "The company is constantly evaluating our resources and staffing needs and trying to match these things up against market conditions and all sorts of other things. This is just good, prudent management."

Most of the voluntary layoffs will be instituted in the US. Of the company's 105,000 employees worldwide, about 65,000 are employed domestically, Sengstock said.

Divisions targeted are the communications sector—which includes portable and mobile radio, paging, microwave—and the semiconductor sector—including power products, microprocessor products and the standard logic and analog integrated circuits groups.

"Neither of those two businesses is in particular trouble," Sengstock noted. "But within the two sectors, there are certain businesses that have not been performing up to an acceptable level."

He would not be more specific about those divisions, however, he did say that AM stereo engineers did not fall within the sectors.

If 2500 employees do not volunteer, Sengstock said involuntary layoffs would be necessary. The company hopes to secure volunteers by mid-November. Attrition and inter-company business transfers also are expected to help reduce the workforce.

For information, contact Motorola at 312-576-4889.

Where Does Your Signal REALLY GO?

CDS Propagation maps are based on extensive REAL WORLD measurements. CDS combines field research, detailed 3 ARC second terrain data and vegetation/urban attenuation data to produce the most accurate depiction of service available today.

Not just Terrain Shielding PROPAGATION STUDIES

- 3 Color graphics
- Finished product—with base map, ready for display
- Calibrated with actual measurements
- 1:100k, 1:250k or 1:500k scale maps
- 1 week delivery
- FM, TV & LM services

For more information or to receive a sample map, call Rich Biby at (703) 534-0034

Communications Data Services
6105E Arlington Blvd.
Falls Church, Virginia 22044

World Radio History

Circle 27 On Reader Service Card

CART MACHINES

Want to Sell

ATC PB-150 tube mdl, seems complete, gd for parts, exc, \$100/BQ. J Sigmon, WBZK, POB 398, York SC 29745. 603-684-4241.

ITC Omega Series (2) playback desks, program cards need minor repair, otherwise excel cond, \$800 ea pls shpg. D Kelley, KISZ, POB 740, Cortez CO 81321. 303-565-1212.

BG Engineering BGE-1T new 10 minute digital up timer for retrofit into Spotmaster/ITC cart decks, BO; new semiconductors, ICS, lamps, motors, switches, rack ears, accessories for PDII, Delta, RP, SP, 3D, WP, Series 99 cart decks, BO. B Royster, KQM, 1019 Cordova, San Diego CA 92107. 619-223-3413.

Telex MC-PR III RP audio, excel cond, \$995. L Chatman, IVA, 424 Commerce Ln Ste 1, Berlin NJ 08009. 609-768-5006.

Automated Broadcast Controls w/4 Otari ARS-1000DC reproducers, (2) 24 cart Carousels, 60 event sequence controller & audio controller, w/manuals, gd cond, \$10,000 pls shpg. B Herrera, KCRF, 100 Fisher, Trinidad CO 81082. 719-846-3355.

Sentry complete automation system including (5) Revox PR-99 stereo PB machines; Instacart; (2) IGM Carousels; (2) Audicord stereo cart machines; PC compatible computer software & interfaces, excel cond. B Ferguson, WMMJ, 400 H St NE, Washington DC 20002. 202-675-4800.

BE 2000 R/P, 2 decks, one has new motor, manual, \$700/both; (3) Ampex 602 R-R decks for parts, BO. B Oostenburg, KCKY, POB 6, Coolidge AZ 85228. 602-963-9290.

UMC Beaucart RP stereo record w/spare parts, manual, 3 tones, \$1125. B Carr, WRED, 1201 Fremont Pk, Toledo OH 43469. 419-837-9696.

ATC Criterion Series mono R/P, gd cond, \$300. B McKittrick, 331 Mulberry, Catasquiqua PA 18032. 215-264-5295.

SMC 510 single cart player (2), \$150 ea/BO. J McDonald, 303-669-3442.

Telex MC-PR III R/P, like new, \$950. L Chatman, IVA, 424 Commerce Ste 1, Berlin NJ 08009.

Rapid-Q ROM-2 R/P mono, fair cond, \$200 or trade. D Kohn, KESM, 200 Radio La, Eldorado Springs MO 64744.

Fidelipac Zenith & height gages for head alignment, never used, \$50. D Bailey, 3422 Beech, Rowlett TX 75088. 214-475-9796.

BE 5302B mono, triple decker, gd cond, \$1300. E Trevino, KBOR, Box 3407, Brownsville TX 78523. 512-541-6348.

3M/ITC Delta I stereo, gd cond, presently working. E Trevino, KBOR, Box 3407, Brownsville TX 78523. 512-541-6348.

SMC 792 mono, gd cond, \$900. E Trevino, KBOR, Box 3407, Brownsville TX 78523. 512-541-6348. Fax 512-542-4109.

3M/ITC Delta I stereo, gd cond. E Trevino, KBOR, Box 3407, Brownsville TX 78523. 512-541-6348.

BE cart tape winder, almost new, w/timer, both in original packing, \$425. G Cahill, Invisible Inc, POB 5786, Hudson FL 34674. 613-725-5003.

BE/Spotmaster TP-1A cart winder, without timer, \$100, will throw in 100 plus carts for \$150; (3) record amps, mono, for RCA RT-27/BA-27 series cart machines, \$40 ea. F Vobbe, Great Northern Bdc Co, POB 5031, Lima OH 45802. FidoNet 1:234/16.

Want to Buy

ITC 3D mono w/WRA record amp, triple deck. C Waitman, KNEW, 66 Jack London Sq, Oakland CA 94607. 415-836-0910.

Parts & manuals for RCA 7 Series; record amp for RCA 7 Series; parts & record amp for Harris Criterion ATC Series. C Gill, POB 371, Indianapolis IN 46206. 317-923-2800.

Rapid cue R/P mono or stereo, any model, schematics & operative units, must work, need several, may be interested in units for parts. N Williams, WTJZ, 553 Michigan, Hampton VA 23669. 804-723-1270.

Eraser splice finder, KDKB, POB 6184, Kingman AZ 86402. 602-753-KDKB.

Tapemaster P & RP 700, any cond from junk to excel, call or write w/descriptions & lowest prices, complete or parts only. T Crockett, Hot Tracks, Box 10501, Blacksburg VA 24060. 703-953-0222.

Stereo record in gd working cond, used carts 40 sec, 70 sec, 100 sec, 2.5 min. A Moll, KIXQ, 128 Memory Trail, San Antonio TX 78232. 512-496-0677.

CASSETTE & REEL-TO-REEL RECORDERS

Want to Sell

Tandberg 74B 4 trk, 3 speed, portable case w/opt plastic lid, service & user's manuals, no mics, mint, BO pls shpg; VM 700 portable 1950's consumer unit, fair cond, BO pls shpg. S Delahoyde, Box 33063, Phoenix AZ 85067. 602-937-9088.

Tascam 38 1/2" 8 trk, low hrs, excel cond, \$1875; Tascam 40-4 4 trk w/dlx, low hrs, \$925. K Flory, The Production Co, Box 1027, Siloam Springs AR 72761. 501-524-4626.

Scully 280-14SP, mono 14", fair cond, \$250; Kahn Symetra-peak SP 58-1A, gd cond, \$50; SMC 282 time announce, gd cond, BO; CBS Audiomax 4450 stereo, gd cond, \$200; CBS Volumax 4100, mono, excel cond, \$200. J Thomas, WLEW, Bad Axe MI. 517-269-9931.

Scully 280B 2 trk stereo in factory roll-around cabinet, manuals, new heads, spare capstan motor & other parts, excel cond, \$1000 pls shpg. B Mounjo, WIDD, 610-1/2 Hattie, Elizabethton TN 37644. 615-543-5849.

Stancil Hoffman CRM-7 logger Young, WJON, POB 220, St Cloud

Crown motor, capstan, Dale Hl bi-directional, Crown player, new athon 702-7 & 702-10 portable bi-directional, auto reverse, call prices. E Davison, 135 N Illinois, IL 62702. 217-787-0800.

Ampex AG-440C 1/2" 4 trk in around cabinet, manuals, heads lile wear, spare set of R/P electro spare parts, vgc, \$1000 pls shpg. WIDD, 610-1/2 Hattie, Eliza 37644. 615-543-5849.

Technics 1520 isolated loop R control in fair cond, \$500. R Sami, POB 83111, Lincoln NE 68501. 41

Scully 270-2 (2) 14" stereo reproducers, 3.75-7.5 ips; also (6 capstan motors, BO; Ampex 35 only w/Schafer electr, excel cond, heads, parts, relays for 350 & BO; PR&E Multisync MDA motor ble speed amp for Ampex & Scull B Royster, KQM, 1019 Cordova, S 92107. 619-223-3413.

Telefunken M15A 24/32 trk 15K & varispd, \$25K; Telefunken M15 \$4K; Tascam 80-8 w/dlx rack Nakamichi 550, BO. R Rhodes, NYYN 10101. 212-245-5045.

Pioneer CT-F2121 stereo (2), lc need minor repair, \$60 ea or \$100 mon, WBZK, POB 398, York SC 684-4241.

ITC 850 Series, gd cond, BO. D 1 901 E Pike Blvd, Weslaco TX 785 1548.

IBM System 34 computer w, drive, 6 yrs old, excel cond, use bine traffic system, \$3500 pls sh WJL, 3342 Perry, Camillus NY

Otari 8 SD 1/2" 8 trk w/calibrati tremely clean & reliable +4 or - tions, \$2500/BO. M Mantell, 1st l 15 Perkins, Brockton MA 024C 1844.

Revox B77 excel cond, \$1000/BO J-Con Ltd, 200 E Rackquet Club, Springs CA 92262. 619-323-435

Teac X-2000R 10.5" 14 trk, 7.5-3 bi-directional 6-head system, aut motor transport, very low hrs, \$1000. G Curry, Int'l Minis: Peachtree Corners Circle Ste 2E GA 30092. 404-449-6766.

Revox A-77 15/7.5 ips w/Dolby B \$450/BO; Revox B-77, 15/7.5 ips, \$1250/BO. B Henry, KLLK, 12 W lits CA 95490. 707-459-1250.

Otari MX5050-4, 1/4" 4 trk, lapped, \$950. B Petrucci, Rouse: E Old Hickory, Madison TN 371 8516.

Ampex 1200 24 trk matched | mods, great shape, heads have b many spares, \$30K/pr, will cons breaking set. D Hewitt, Remote f 334, Lahaska PA 18931. 215-79-

Ampex 601 tape transport, as \$30; (3) Rotron 115 V Whisper far ment cooling, \$10 ea or \$25/al Welch Media, POB 1455, Moncks 29461. 803-781-7585.

Recordex 330II cassette duplicer & 3 slaves, 16X duplication s matic rewind, erase heads, long-ri ord heads, LED level meters, \$700 ry, Int'l Ministries, 4725 Peachtr Circle Ste 250, Norcross GA 3006 6766.

Sony/MCI JH-110B-2 R-R consok (2), light use, new heads & pinchr capble, (2) technical manuals & control, \$2800/ea. B Koitz, KBAY San Jose CA 95150. 408-370-3777.

Otari 5050B2 7.5 & 1.5 ips 2 trk, less than 1 yr old, excel cond w/manual, \$950/firm. S Mahaffey, Mahaf Prod, 3592 N Delsea Ste 12, Vineland NJ 08360. 609-692-3439.

Otari ARS-1000 in excel cond, (4), \$700 ea. C Kner, KCNA, 139 SE J St, Grants Pass OR 97526. 503-474-7564.

Scully 1/2 trk tape heads (26) play; (12) mo-no Magnacord Presto, play; (16) Magnacord stereo lapped Presto, play, sacrifice price. Call 616-782-9258.

Ampex AG 440B 2 trk, 7.5-15 ips in Rusalng console (2), \$700; Ampex 351-2 trk 7.1-15 ips w/Inovonics 360 electronics in Rusalng console (2), \$400; Ampex 351 FT 7.5-15 ips in Rusalng console, \$250; Ampex 351 electr (4), \$100. B Reider, WGUC, 1223 Central Pkwy, Cincinnati OH 45214. 513-556-4444.

Scully 280B 4 trk 1/2" in factory roll-around cabinet, manuals, new heads, spare capstan motor & other parts, excel cond, \$1200 pls shpg. B Mounjo, WIDD, 610-1/2 Hattie, Elizabethton TN 37644. 615-543-5849.

Ampex 350 FT w/Inovonics electr in roll around walnut floor cabinets (2), \$800 ea; Scully 280B 4 trk 1/2" recorder, gd cond, in roll around walnut floor cabinets (2), \$1100 ea.

Revox tape recorders, top-shape factory rebuilds. New heads, etc. Accessories. A77, \$850; B77 (14 trk 7.5 ips), \$1000; G36 (tube mdl) 1/4 trk 7.5 ips, \$500. Send phone number & address to: JM Technical Arts, POB 8156, Hermitage TN 37076.

Ampex AG-440A-R, gd cond, \$450; Ampex AG-602-2-p, new, \$775; Ampex PR-10-2-p, very gd cond, \$850; many others, call Marlin at 219-322-7090.

Want to Buy

Sony TC 788-4 4 trk in gd cond & w/maintenance manual. C Fuller, Voices, POB 153, LaGrande IL 60525. 312-579-9578.

The hardest place to find our products.

Any time you care to scan the broadcast equipment classifieds, you can find most of the major names in our industry—with one notable exception. Products manufactured by Pacific Recorders & Engineering seldom if ever show up in these pages.

That should tell you two important things about our equipment. One, it has a very long life. Two, it's in such demand, even after years of use, that it's almost never advertised. Instead, the engineer who's replacing his BMX consoles (usually because his station or network is building new facilities with new PR&E equipment) simply calls a few friends. Once word gets around that some of our gear is available used, it's quickly sold.

Pacific Recorders & Engineering consoles and cart machines are never hard to find. Try any major market station, network studio or smaller facility where professionals demand tools that work as hard, as well, and as long as they do. But please, don't waste your time looking in the classifieds.

Of course, the enduring worth of PR&E equipment is another excellent reason most people buy it new, direct from the source. Just call us at (619) 438-3911 for complete information on BMX Series III consoles or any of our other products and services.



PACIFIC RECORDERS & ENGINEERING CORPORATION

2070 Las Palmas Drive
Carlsbad, CA 92009
Tel (619) 438-3911 Fax (619) 438-9277

Circle 93 On Reader Service Card

Scully 280-1 (2), ea in Rusalng roll-around cabinets w/overbridge, \$3000/pr; (4) Scully 270-2 stereo PB, late mdls, manual, \$3K/all; Ampex AG440B electr chassis, as-is, \$100; Telex 4-chnl, slow-speed logger system, current mdl, \$2000/all; Tape-A-Thon Programmer III, current mdl, \$5000. E Stolz, KWOD, 1425 River Park, Sacramento CA 95815. 916-929-5000.

Scully 255 reproducer, 1/2 trk, stereo, BO. KDKB, POB 6184, Kingman AZ 86402. 602-753-KDKB.

Ampex 350, 7.5-15 ips, FT, cabinet mounted, \$400; Teac A1200, complete, cond unknown, \$100/BO. J McDonald, 303-669-3442.

High speed cassette duplicator mono or stereo to record 10 at one time in working cond, need not be Elabria. R Sweetie, KOKR, 600 Bowdy Ste 220, Kansas City MO 64105. 816-421-1065.

ATR100 taperecorders for parts. Circuit cards, heads, motors, machine parts, or electronic parts. Call 818-907-5161.

MCI/Sony capstan & reel motors, any cond., recd heads, most mfgs. machines, new, used. Relapped then sold. Amp Services, 224 Datura St, No 614, W Palm Beach FL 33401. 800-828-0601, in FL 305-659-4805.

CONSOLES

Want to Sell

Autogram AC-8/IC-10 spare parts, lamps, switches & bridging input transformers, BO. B Royster, KQM, 1019 Cordova, San Diego CA 92107. 619-223-3413.

Numark DM 1550 4 chnl DJ mixer, 2 phono inputs, 2 line inputs, 2 mic inputs, 6 band graphic EQ, always in road case, excel cond, \$150. B Fisher, KPOK, Box 477, Bowman ND 58623. 701-523-3883.

Autogram AC-8/IC-10 spare parts, lamps, idging input transformers, BO. M, 1019 Cordova, San Diego CA 92107. 619-223-3413.

1550 4 chnl DJ mixer, 2 phono inputs, 2 mic inputs, 6 band lways in road case, excel cond, r, KPOK, Box 477, Bowman ND 23-3883.

h Systems 8 16 input, 8 subs, 3 effect sends, +4 or -10 level cond, \$3000/BO. M Mantell, 1st 15 Perkins, Brockton MA 02401.

Executive 10 chnl stereo solid-in clean, vgc w/manuals, \$1000 Mounjo, WIDD, 610-1/2 Hattie, TN 37644. 615-543-5849.

d cond, BO; Cetec 2000 8 pot, r supply, gd cond, BO. D Wolfe, Pike Blvd, Weslaco TX 78596.

Grandson 18 input console, eck 33X16 rcdg console 3-band fch bay plus 24 tr harness, Freeman, Pranava Prod, 1227 ay, Los Angeles CA 90069. 213-

o 80 complete w/pwr supply, iders new, works fine, 3 mic in-, includes book, \$800. C Ben-40 Domino Ln, Philadelphia PA 13-8900.

10 chnl, all plug-in amps, digi-omplete set of spare PC boards, wn, WPRS, POB 367, Paris IL 5-6336.

15 8 chnl stereo, excel cond, all tras, \$5500. R Trumbo, KNLF, incy CA 95971. 916-283-4144.

AC-6 6 chnl 23 input stereo, in-cludes ESE built-in timer, shpg. D Kelley, KISZ, POB 740, 1321. 303-565-1212.

12x8x8, lots of extra features, t cond, \$2900. K Flory, The o, Box 1027, Siloam Spring AR 4-4626.

pee A/B 20x16 w/8) 9-band ull patch bay, producers desk, rich, Box 869, Greenville CA 34-6929.

112, 12x4x2, \$1500. C Green, rogramming. 800-937-2100.

12 in, stereo out & mono & mon-1, \$500. D Bailey, 3422 Beech, 5088. 214-475-9796.

, modified to 7 inputs, complete : & manuals, gd cond, BO; Kel-omote broadcast console w/2) proof speakers, gd cond, BO. J , POB 1070, Sunbury PA 17801.

7500 stereo console parts, P&G in preamps, etc. J.C. Aegeter, W Center, Milwaukee WI 53210.

w/4 pots; (2) Ramko solid state; 2 tube type w/6 pots; ATI 8 chnl stereo w/pwr supply, call for details. Adolph, 915-949-2112.

IL 16x8 monitor mix console, 9 EQ pads, solos, etc, \$950. B ise St Prod, 804 E Old Hickory, 37115. 615-868-8516.

20 20 chnls, mint cond, 6 mos Miller, Airborne Audio, 11647 W nexa KS 66214. 913-492-8822.

1 5000, 24 inputs, 4 outputs, 3 band, 5 frequency EQ, Duncan spare modules & case, \$2300. ouse St Prod, 804 E Old Hick-TN 37115. 615-868-8516.

Midas Pro Custom Recording, 16x8, Remix switch-over, (8) Pro 5, (8) Pro 3 modules, peak meter, clock/timer, flight case, \$10,500. H Al-rich, Box 869, Greenville CA 95947. 916-284-6929.

Harris Micromac 16 input mainframe, manu-als, spare pwr supply, \$10,000/BO. V Killion, KRYN, POB 880, Lexington NE 68850. 308-324-6717.

RCA BC8A dual mono console, clean shape, \$500 plus crating & shipping. J Kreines, DeMott/Kreines Films, 5330 Kennedy, Millbrook AL 36054. 205-285-6179.

Allen & Heath Systems 8 16 input, 8 subs, 16 monitors, 3 effect sends, +4 or -10 level options, excel cond, \$3000/BO. M Mantell, 1st Impressions, 15 Perkins, Brockton MA 02401. 508-580-1844.

Gates/Harris Executive 10 chnl stereo solid-state console in clean, vgc w/manuals, \$1000 pls shpg. B Mounjo, WIDD, 610-1/2 Hattie, Elizabethton TN 37644. 615-543-5849.

RCA 8 pot, gd cond, BO; Cetec 2000 8 pot, 16 input w/pwr supply, gd cond, BO. D Wolfe, KRUX, 901 E Pike Blvd, Weslaco TX 78596. 512-968-1548.

Audiotronics Grandson 18 input console, \$3800/BO; Speck 33X16 rcdg console 3-band sweep EQ, patch bay plus 24 tr harness, \$3795/BO. G Freeman, Pranava Prod, 1227 Sierra Alta Way, Los Angeles CA 90069. 213-457-8390.

Gates Stereo 80 complete w/pwr supply, most rotary faders new, works fine, 3 mic input 4 line input, includes book, \$800. C Ben-ner, WUUL, 440 Domino Ln, Philadelphia PA 19128. 215-483-8900.

QRK Omega 10 chnl, all plug-in amps, digi-tal switches, complete set of spare PC boards, \$4500. B Brown, WPRS, POB 367, Paris IL 61944. 217-465-6336.

Ramko DC8M5 8 chnl stereo, excel cond, all manuals & extras, \$5500. R Trumbo, KNLF, POB 117, Quincy CA 95971. 916-283-4144.

Autogram AC-6 6 chnl 23 input stereo, in excel cond, includes ESE built-in timer, \$4200/BO pls shpg. D Kelley, KISZ, POB 740, Cortez CO 81321. 303-565-1212.

Tascam M-50 12x8x8, lots of extra features, low hrs, mint cond, \$2900. K Flory, The Production Co, Box 1027, Siloam Spring AR 72761. 501-524-4626.

Sphere Eclipse A/B 20x16 w/8) 9-band graphic EQ, full patch bay, producers desk, \$6000. H Alrich, Box 869, Greenville CA 95947. 916-284-6929.

Ramsa WR 8112, 12x4x2, \$1500. C Green, Century 21 Programming. 800-937-2100.

EV EVT 5212 12 in, stereo out & mono & monitor, mint cond, \$500. D Bailey, 3422 Beech, Rowlett TX 75088. 214-475-9796.

RCA BC5A (2), modified to 7 inputs, complete w/spare parts & manuals, gd cond, BO; Kel-son KD20A remote broadcast console w/2) TTs, (2) waterproof speakers, gd cond, BO. J Keller, WKOK, POB 1070, Sunbury PA 17801. 717-286-5838.

McCurdy SS-7500 stereo console parts, P&G faders, plug in preamps, etc. J.C. Aegeter, Satcom, 5431 W Center, Milwaukee WI 53210. 414-445-2300.

BE 4BEM 50 w/4 pots; (2) Ramko solid state; Collins 212 F-2 tube type w/6 pots; ATI 8 chnl stereo w/pwr supply, call for details. Adolph, 915-949-2112.

Interface 104L 16x8 monitor mix console, 9 freq, 3 band EQ pads, solos, etc, \$950. B Petrucci, Rouse St Prod, 804 E Old Hickory, Madison TN 37115. 615-868-8516.

Tascam M-520 20 chnls, mint cond, 6 mos old, \$4250. D Miller, Airborne Audio, 11647 W 83rd Terr, Lenexa KS 66214. 913-492-8822.

Sunn Magna 5000, 24 inputs, 4 outputs, 3 aux sends, 3 band, 5 frequency EQ, Duncan faders & (2) spare modules

Quake Ravages San Francisco

City and Outlying Area Lose Radio Service Due To Devastating Disaster

by Alan Carter

San Francisco CA "The towers were actually starting to whip around."

That description of the KGO-AM three-tower antenna array system from Operations Director Jack Swanson gave a graphic description of just how severe the earthquake that shook Northern California on 17 October was. The 309' towers are anchored in about 8' of concrete.

When all was calm—about 15 seconds later—one tower was bent in half, the second was bent at about 200' and the third had "a pretty good lean on it," Swanson said.

Initial reports here the morning after the earthquake indicated that KGO suffered the most damage by broadcasters in the immediate San Francisco area. All broadcasters—radio and television—went off the air when power was knocked out.

California Broadcasters Association Executive Director Vic Biondi was not able to get immediate reports from outlying regions because communication was almost impossible.

Stations south of San Francisco in Santa Cruz, Los Gatos and Watsonville, where the epicenter of the earthquake that registered a 6.9 to 7 on the Richter scale was located, were off the air the day after the quake (at press time). Biondi speculated they may have suffered structural damage.

KGO, an ABC O&O that is all news,

was off the air for about an hour before it returned with backup power and with a signal from the one tower not destroyed. At first power was down from its usual 50 kW directional signal to 10 kW non-directional and later increased to 25 kW.

"I think we'll be at 25 for a while," Swanson said. "Some stations would kill

for 25 kW (under normal circumstances)."

During the night, KGO offered feeds to ABC affiliates via satellite, according to ABC Radio Publicity Manager Lesley Halpern in New York. ABC Radio Network also offered "Nightline" and ABC-TV reports to affiliates.

(continued on page 23)

Relief Arrives for Hugo's Victims

by Charles Taylor

Spencer IA KICD AM/FM's station truck has a sign on the side that reads, "Full Service Radio."

Don't think they don't mean it.

The station was responsible for loaning and delivering a 90' tower to WJJC-FM in St. Croix, Virgin Islands, after the station lost its tower amid Hurricane Hugo's destructive path.

Toting a tower

"This facility has a long tradition of always having stuff around," said KICD's CE Joe Schloss. "This tower was just sitting on the ground collecting dust, so we loaded it in the truck and headed for Florida."

All in all, Schloss and his brother Tim took turns behind the wheel and in 67

hours, toted the tower 3838 miles.

The loan evolved out of an equipment cooperative—the first of its kind—arranged by the NAB to help link broadcasters in need following Hugo's wrath with others nationwide that had equip-

wiped out, both transmitter and studios," said Stan Salek, of NAB's Science & Technology department and one of the team sent to South Carolina to assess damage.

In Charleston, all TV and radio sta-

The loan evolved out of an equipment cooperative—the first of its kind—arranged by the NAB . . .

ment to spare.

Following the hurricane's destruction, NAB sent a team of staffers to both Charleston and San Juan, Puerto Rico to assess the damage.

"We saw everything from stations with no power and everything else OK, all the way up to stations where everything was

tions were knocked off the air during the worst of the storm, NAB said, and a number were still struggling to return to the airwaves two weeks after.

The damage in Puerto Rico and the Virgin Islands was even more extensive; between 12 and 15 broadcast towers (continued on page 23)

PUT YOUR PC ON LINE WITH THE NEW PC ACCESSIBLE MRC 1620 REMOTE CONTROL SYSTEM

As a broadcast engineer, you want to utilize the newest PC technology that will work intelligently and make your job as easy as possible. The Moseley MRC 1620 is the first intelligent, PC-accessible, integrated package that will do just that. This cost-effective system consists of a stand alone Remote Terminal that allows an optional Control Terminal or IBM PC with TaskMaster20 software to monitor and control remote facilities from dedicated and/or dial-up control points.

The MRC 1620

- Operates as a stand alone dial-up Remote Terminal or with standard studio Control Terminal.
- Dual communication ports at Control and Remote Terminal allow direct and dial-up access at either terminal.
- Comes standard with 32 relay isolated commands, 16 telemetry and 16 status channels with filtered terminal blocks.
- Front panel LEDs provide visual indicators of input channel and system status. Digital meter displays telemetry, channel value, calibration and limits.

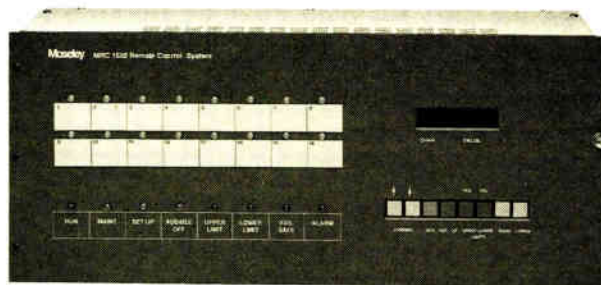

Make the Intelligent Choice! The MRC 1620 Remote Control System

MRC 1620	MRC 1620	MRC 1620	MRC 1620	MRC 1620	MRC 1620	MRC 1620	MRC 1620	MRC 1620	MRC 1620
1	6.2	141.0	15.7	14.2	14.2	14.2	14.2	14.2	14.2
2	2.35	141.0	15.7	14.2	14.2	14.2	14.2	14.2	14.2
3	2.17	141.0	15.7	14.2	14.2	14.2	14.2	14.2	14.2
4	188.8	141.0	15.7	14.2	14.2	14.2	14.2	14.2	14.2
5	15.8	141.0	15.7	14.2	14.2	14.2	14.2	14.2	14.2
6	141	141.0	15.7	14.2	14.2	14.2	14.2	14.2	14.2
7	6.3	141.0	15.7	14.2	14.2	14.2	14.2	14.2	14.2
8	5.6	141.0	15.7	14.2	14.2	14.2	14.2	14.2	14.2
9	2.34	141.0	15.7	14.2	14.2	14.2	14.2	14.2	14.2
10	99.9	141.0	15.7	14.2	14.2	14.2	14.2	14.2	14.2
11	51.8	141.0	15.7	14.2	14.2	14.2	14.2	14.2	14.2
12	23.5	141.0	15.7	14.2	14.2	14.2	14.2	14.2	14.2
13	43.5	141.0	15.7	14.2	14.2	14.2	14.2	14.2	14.2
14	218	141.0	15.7	14.2	14.2	14.2	14.2	14.2	14.2
15	287	141.0	15.7	14.2	14.2	14.2	14.2	14.2	14.2
16	286	141.0	15.7	14.2	14.2	14.2	14.2	14.2	14.2

The TaskMaster20 Software

- The easy to use software automatically adjusts out of parameter conditions according to user defined control strategy.
- Current alarm conditions are displayed on an "alarm" page. Up to 20 of the latest alarms and hourly log data from the last 30 hours (stored in battery backed RAM of the MRC 1620) can be reviewed at your convenience.
- Monitors up to 63 sites.
- Remote set-up attributes and calibration may be downloaded from the remote terminal and stored to disk for editing and future uploading.
- Three levels of password security.

For your free TaskMaster20 software demo disk, contact Moseley Marketing at 805-968-9621.

Moseley

Moseley Associates Incorporated

111 Castilian Drive
Santa Barbara, CA
93117-3093

a
Flow General Company

Phone 805 968 9621
Telex 658448
FAX: 805 685 9638

Feature Shock!

Otari's new MX-50. Built around the premise that you can have everything you ever wanted in a two-track tape machine, and still stay within your budget. For example:

The Transport

—DC quartz PLL capstan motor with front panel selection of operating speeds (from either a 15/7.5 or 7.5/3.75 ips speed pair).

—Capstan speed variable by $\pm 7\%$ from the front panel, and by $\pm 50\%$ from SMPTE

time-code external controllers via an Otari-standard 37-pin connector.

—Optional remote control.

The Electronics

—Lighted VU meters with peak-reading LED indicators.

—Transformerless active balanced inputs with XL-type connectors.

—Optional Voice Editing Module (VEM) for twice normal play speed with normal pitch.



A built-in tape timer displays current tape position in hours, minutes, and seconds, and includes a search-to-cue locator with cue point and zero location memories.

Otari's MX-50. For whenever or wherever you need a professional

audio machine at an affordable price.

For more information, call your nearest Otari professional audio dealer, or Otari Corporation at (415) 341-5900.

OTARI

10.5" reel size capacity with self-centering NAB hub locks.

$\pm 7\%$ vari-speed.

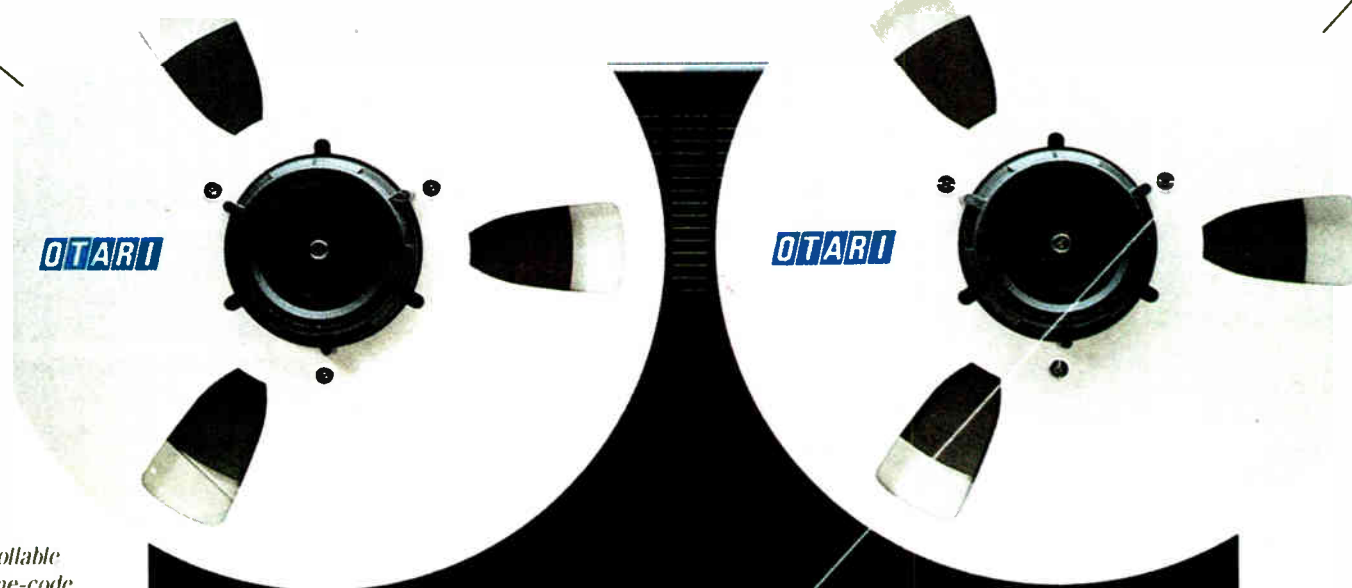

Capstan speed controllable $\pm 50\%$ via SMPTE time-code external controllers.

Optional Voice Editing Mode (VEM) for twice normal play speed with audio pitch shifted down one octave for normal pitch.

Alloy deckplate.

Lighted VU meters with peak-reading LED indicators.

Headphone amplifier with front-panel headphone jack and level control.

Optimized record and reproduce heads.

Switch-selectable NAB/IEC EQ with front panel indicator.

Lifter defeat with momentary or locked operation.

Tape drive tachometer for accurate tape time display, and for external synchronizer or controller interface via Otari-standard 37-pin connector.

DC quartz PLL capstan motor with front panel selection of operating speeds.

Independent reel size selectors for supply and take-up motors.

Built-in tape timer display.



©1989 Otari

NEW! The Lazer Studio.



Equipped . . . Furnished . . . Prewired!

The excitement at Radio '89 in New Orleans was at Booth 753. That's where Radio Systems showed the first Lazer studio . . . a complete package for an unbelievable price!

This studio includes: The RS-12 stereo console, our most popular board.

Famous Radio Systems furniture, custom-made to your room. A full complement of source and monitoring gear including cart machines, reel-to-reel deck, CD or cassette, speakers, microphone, and more.

ALL FOR \$24,995!

Lazer prewiring with all source cables and connectors. The studio ships to you, pre-tested and ready to plug together in just five hours. Or, you can have Radio Systems engineers assemble it for you on site.

Call us for a quote on your studio, just the way you want it. We'll send you a quote on your exact layout and equipment—at similar savings.

The company that invented turnkey studios now makes them more affordable. Call Radio Systems toll-free for details.



RADIO SYSTEMS INC.

110 High Hill Road P.O. Box 458 Bridgeport, New Jersey 08014-0458
609/467-8000 800-523-2133 Fax 609/467-3044

Circle 54 On Reader Service Card

World Radio History

Emergency in Bergen Radio

(continued from page 1)

reported or under-reported by stations that include the county in their transmit coverage.

After twice rejecting the Turro proposal, the FCC is again formally considering local origination on W276AQ—at Turro's request.

In comments filed in October with the FCC, the NAB and a host of broadcasters from as far away as Wisconsin, Arizona and California attacked Turro's request.

Most claimed that Bergen has a plethora of local radio services—60 to 80 stations—and that granting local origination to the 8 W translator would open the door to swarms of similar waiver requests.

Opponents also contended that the Turro request should be examined only within the broader context of the ongoing FCC translator inquiry in MM Docket 88-140.

"This county may be saturated by radio signals; that does not mean we are well served."

In response, Turro argued that the issue/programs lists of area stations show little service specifically to Bergen County and that citizens could not wait for the FCC's "slow-moving" translator proceeding.

According to Fort Lee Mayor Nicholas Corbiscello, "This county may be saturated by radio signals; that does not mean we are well served. Not one shred of evidence has been presented by these 'outsiders' to show that Fort Lee and the rest of this county receive radio programming geared to our needs."

Emergency transmissions

In theory, the county's declaration of emergency could allow the translator to originate programming beyond the 30 seconds per hour normally permitted. Rule 74.1231 (g) provides that, in emergencies, a translator's local transmissions shall be no longer or more frequent than necessary to protect life and property.

Turro's attorney, Ray Kraus, however, downplayed such a scenario.

"While I think you could go on the air in a storm or imminent emergency, that is not really what the (county) Freeholders had in mind, and it wouldn't solve our problem," he said.

"The purpose of the declaration (of the state of emergency) is to demonstrate the strong feelings they have and to show that they hope the Commission will act on this urgent need."

He said his client does not intend to immediately use the emergency declaration to begin local origination

on the translator.

The board's resolution reads in part: "To continue without the benefits of ... immediate communications is an endangerment of the public's safety and welfare and virtually places the people of Bergen County in imminent danger"

"The Board of Chosen Freeholders urges that the people of Bergen County be accorded the safety and welfare protection available only through the im-

mediacy of 24-hour FM radio and to that end declare a radio state of emergency; and ... urges the Federal Communications Commission to grant full-service 24-hour FM radio status immediately to Gerard Turro for translator W276AQ."

"We are distressed by comments filed by broadcasters against this proposal and we desperately need service in our county," the county board wrote the FCC.

"The Commission must make note that 99% of these negative comments are from groups outside of Bergen County. How can these groups truly know our needs? How can they serve the needs of this county when they are not only detached from our community, but their radio signals do not even reach our county?"

For information from Turro, contact attorney Ray Kraus in Washington at 202-467-5700.

K-Lite 100.3 FM
All Music, All Memories...
PIRATE RADIO
100.3 FM
WELCOME TO THE JUNGLE

Mr. Steve Church
Telos Systems
1729 Superior Avenue
Cleveland, OH 44114

Dear Steve,

Just a quick note to say how much we love the Telos 100. When I was in New York and Detroit, I had the Telos 10's and they were great- but now you've really outdone yourself.

Here in LA, we use phones all the time so phone quality is extremely important. We rely on our equipment to perform flawlessly. Every time. And if it's not right, we've missed a good opportunity to gain on the competition. Especially with Scott Shannon's morning show. And because Scott's a major league perfectionist, he doesn't pull any punches when it comes to letting me know if something makes him unhappy.

We often record phone bits while listening to the caller on a small monitor speaker. The "acoustic duck" function in your latest software allows us to crank the gain higher than ever. Without any feedback- even on very weak calls.

And every time I install one of your software upgrades, it's like getting a new hybrid complete with the latest technology- for free!

When Scott is happy, I'm happy. Out here in the Jungle, we're all very impressed with the Telos 100. It's the best!

Warmest regards,
Jim Huste
Jim Huste
Chief Engineer
Pirate Radio/KQLZ

BRADLEY BROADCAST SALES 1-800-732-7665
BROADCASTER'S GENERAL STORE 904-622-9058
CROUSE-KIMZEY COMPANY 817-737-9911
PACIFIC RECORDERS & ENGINEERING 619-438-3911

Please contact your dealer or
Telos Systems for a free version 7.0 upgrade.

Telos
SYSTEMS

PHASE TRAK 90™

The perfect cart machines for an imperfect world.



PHASE TRAK 90 PLAYBACK &
PHASE TRAK 90 RECORD/PLAYBACK

Do you really need a cart machine as good as Phase Trak 90? In a perfect world, perhaps not. After all, there'd be no tape skew or phase error in an ideal universe. So, you wouldn't need the continuous non-encoded phase correction circuitry* we developed for Phase Trak 90 cart machines. This BE-exclusive process is so effective, it actually cleans up stereo carts that sound dull on ordinary machines, while assuring consistently clear mono performance. In a perfect world, tape formulation and performance

would be consistent from batch to batch and brand to brand. There'd be no need for the Record/Playback Phase Trak 90's Automatic Tape Analysis system with Learn Mode.

On a fault-free planet, all audio formats would be created equal. Then you wouldn't need Phase Trak 90's superior cartridge guidance system, Phase Lok V head block and CD-quality sound, including our Dynafex® noise reduction system that audibly improves stereo signal-to-noise performance.

And of course, in a perfect world DJs would always treat

cart machines with care and respect. So you could get by without Phase Trak 90's robust, fully modular design featuring a solid die-cast front panel, machined 1/2"-thick aluminum deck plate, cool DC servo motor drive, Hall effect switches and gold-to-gold interconnects. Phase Trak 90: Quite simply, the best cart machine ever made for the real world. If that's where you live and work, call Bob Arnold at (217) 224-9600, or ask your Broadcast Electronics distributor for more information.

* Patent Pending
Dynafex is a registered trademark of Circuit Research Labs, Inc.

BE® **BROADCAST
ELECTRONICS INC**

4100 North 24th Street • P.O. Box 3606 • Quincy, IL 62305
Tel: (217) 224-9600 • Fax: (217) 224-9607 • Tlx: 250142

SBE Show Products at a Glance

Allied's Squeeze Play (right) is a state-of-the-art "skimmer" for stations.

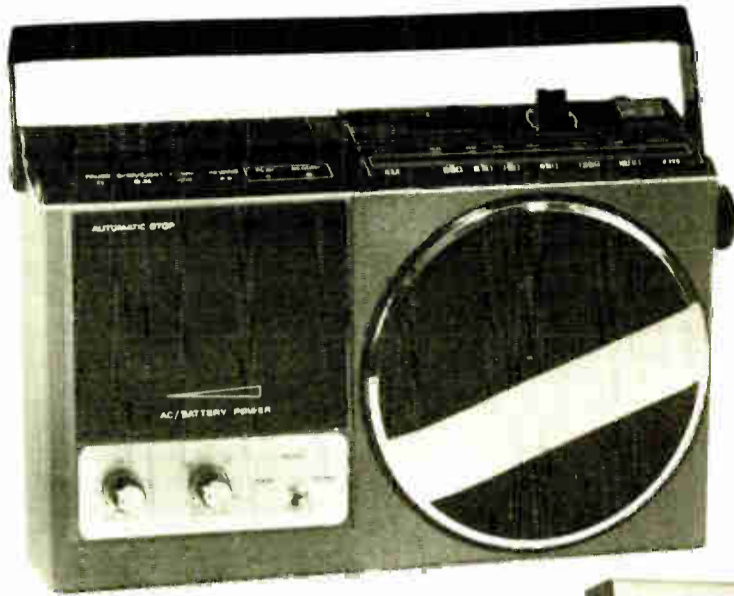

The Kansas City Convention Center (below) played host to more than 3,000 attendees.



Burk Technologies showed the latest in transmitter remote control (above).

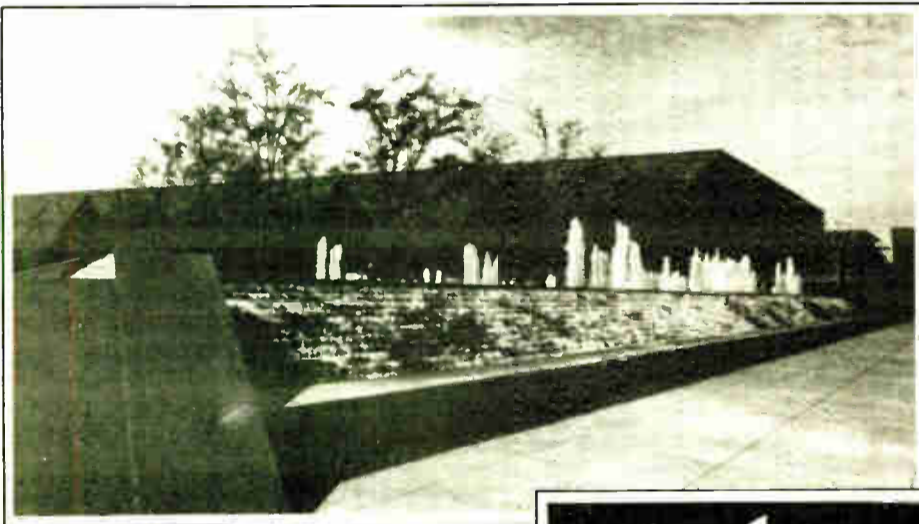

A complete dubbing center from Henry Engineering was also featured at the Allied-Harris booth (left).



Steve Kravitz displayed a new personal radio with AM stereo and FM stereo from Sangean (below).



Engineers had a chance to talk at length with company reps (above).



Harris-Allied introduced a new low power solid state FM transmitter (left).



QRI's CATLink was a big draw for CEs (left).

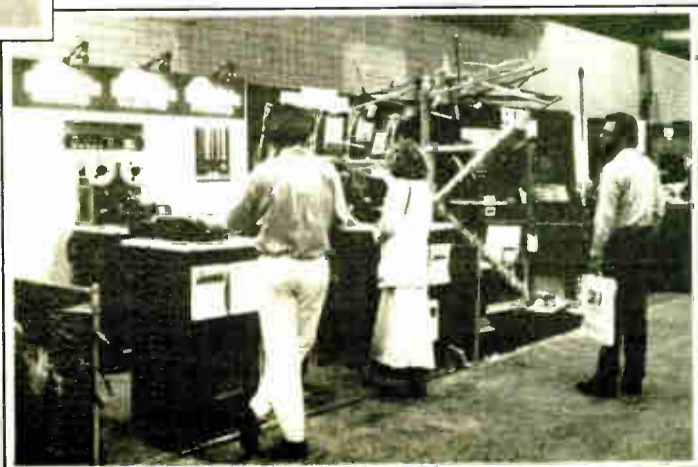

Eventide's effects and delay units generated interest (left).

RF Takes Center Stage at SBE

With Nearly 150 Firms, Convention Exhibition Tempts Show Attendees

by Judith Gross

Kansas City MO The SBE national convention saw few new product introductions, with many companies duplicating their Radio '89 efforts of three weeks previous.

There were one or two new showings, but attendees got a chance to take a closer look at recent introductions and had more time to ask questions in an environment which catered to engineers.

In addition there were several companies which had opted to show in Kansas City instead of at Radio '89 and all voiced satisfaction with the decision.

On the road again

Many companies shipped their booths straight from Radio '89 in New Orleans to Kansas City. Initial worries about the demise of Braniff, the main air carrier into Kansas City, caused only small problems with exhibitors and attendees alike managing to reschedule onto other carriers.

Radio, audio and RF companies mingled with TV and video manufacturers in a filled showcase hall. Nearly 150 companies exhibited at the convention,

which was carefully scheduled so that the 12 hours of exhibits did not conflict with four and a half days of seminars.

The exhibit floor opened with a two hour reception the first evening. Free drinks brought attendees crowding into the hall, and several other activities planned throughout the three days the exhibits were opened also helped generate successful traffic.

Most of the new products—and ones generating the most enthusiasm—came in the RF arena.

Timely debut

Hot on the heels of the FCC's decision to allow Class A FM stations to upgrade their power were two transmitter introductions aimed at those eligible for the upgrade.

Continental Electronics introduced a new solid state FM transmitter group. Kicking off the line is the 1000/500 W 813A designed for Class A's.

It is available in either 1000 or 500 W and uses the Ultimate 802A 50 W exciter. The new model is all solid state, features modular construction and Continental says it is taking orders now for early 1990 delivery.

Harris Corp. made its second showing of the HT 7FM, a 3 to 8 kW FM transmitter introduced at Radio '89. It is also designed for Class A upgrades and uses the 55 W THE-1, Harris' solid-state FM exciter.

Harris also showed a new 500 W solid state FM transmitter, also available in 250 and 1000 W as part of the HT series.

More RF

Other product news from the SBE show also seemed to focus on RF equipment. QEI again drew crowds eager to have a close-hand look at the CAT/Link digital composite STL system, as well as its FM transmitters.

News in the area of STLs also came from TFT, whose Reciter system, which offers an STL receiver and FM exciter in a single package was granted type acceptance from the FCC.

TFT, which introduced the product at the NAB spring show but had been waiting for acceptance from the FCC, said that the Reciter is designed to give broadcasters "CD quality audio in FM."

The question of STL type acceptance by the Commission weighed heavily on the minds of manufacturers and CEs alike at the convention. The impact of a new rule which takes effect in July of 1990 requiring type notification of STLs was the subject of several discussions.

At a press conference the SBE board voiced concern about the new requirements and raised the possibility of a filing asking for more time to implement notification requirements.

Some manufacturers expressed initial

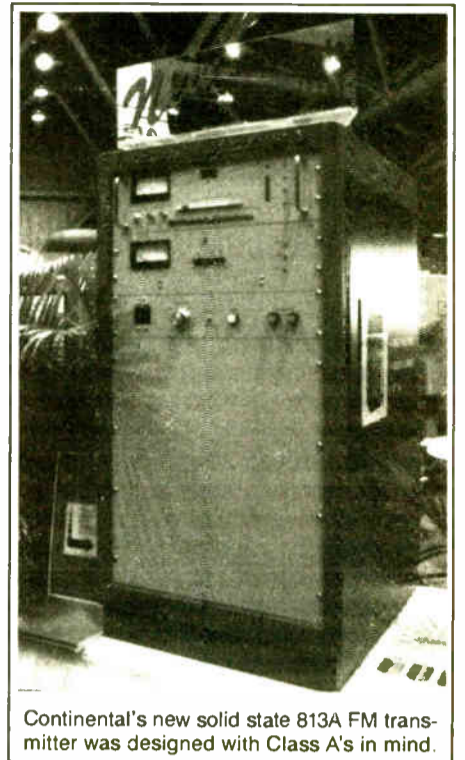

Continental's new solid state 813A FM transmitter was designed with Class A's in mind.

concern about performing type notification tests and notifying the Commission on the installed base of equipment. But in light of clarification from the FCC, STL manufacturers are now saying they will help gain the type notification on newer equipment in the field (see related story, this issue).

Overall, companies exhibiting at the show were pleased with the numbers of attendees, and many have already signed up for next year's SBE convention, which moves back to its original locale in St. Louis.

Now Class A's can go First Class!

If your Class A is planning to move up in power, Harris' new HT 7FM transmitter is ready to take you there, first class. With up to 8 kW output, it's the perfect choice to upgrade Class A facilities. And the new HT 7FM represents some of Harris engineers' most advanced thinking on the subject of FM transmitter design:

- 55W THE-1 Exciter, with ultra-linear VCO, sounds as good as it specs
- Broadband solid state RF driver for the utmost in reliability
- High efficiency single tube in a wideband 1/4 wave PA output cavity for superior performance
- Automatic AC restart, VSWR foldback and power control functions
- FLEXPatch™ RF patching keeps you on the air in an emergency
- Single phase power standard, three phase power available
- Full remote interface standard
- Unsurpassed factory support

Need a replacement for an older transmitter? Need more power? Don't just step up. Step forward, with a Harris HT 7FM.

For more information on Harris RF products, call toll-free (800) 4-HARRIS, Ext. 3021. And for the widest selection of studio products, call Allied Broadcast Equipment at (800) 622-0022.



Harris Broadcast Division • Marketing Department
P.O. Box 4290 • Quincy, IL USA 62305-4290

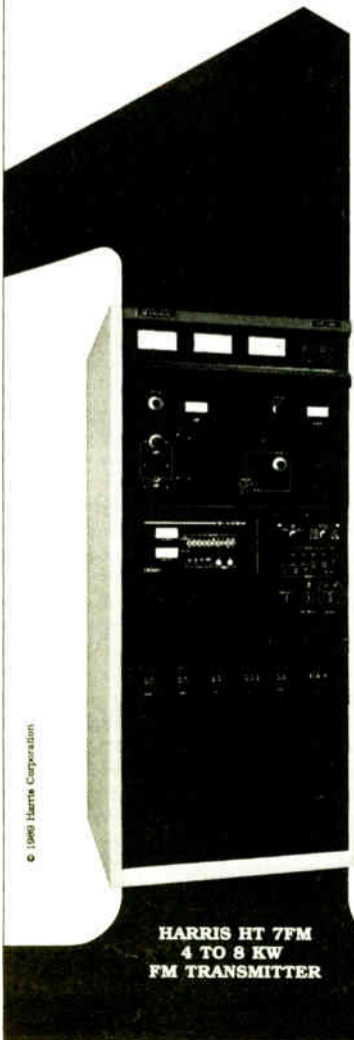

HARRIS HT 7FM
4 TO 8 KW
FM TRANSMITTER

Circle 72 On Reader Service Card



DIGITAL DOWNLINK EQUIPMENT

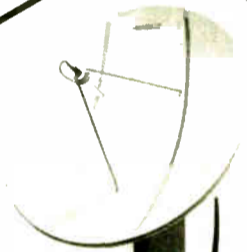

COMTECH
3.8 METER
ANTENNA



DOWN-
CONVERTER

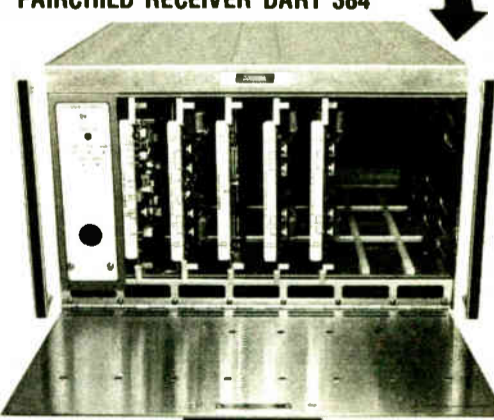

FAIRCHILD RECEIVER DART 384

The Fairchild DART-384 Digital Audio Receiver allows the reception of program material broadcast via satellite using digital techniques. It is fully compatible with the high-quality digital satellite system currently in use by ALL digital networks plus many special and sports programs.

The Fairchild environmentally-sealed downconverter can be mounted at the antenna or immediately behind the mainframe.

Allied recommends a 3.8 meter Comtech professional antenna for any satellite radio service including digital.

Recommended for reception of ABC, CBS, Dow Jones, Mutual, NBC, Transtar, United Stations, and Westwood One.

- Requires only 10½" of rack space
- Stable crystal-controlled downconverter
- Remote program channel selection
- Remote transponder selection
- Selection of up to 4 transponders

CALL THE EXPERTS
317-962-8596

3712 NATIONAL RD. WEST • P.O. BOX 1487
RICHMOND, IN 47375

317-962-8596

Circle 56 On Reader Service Card

SRO for FM Processing Session

by Barry Mishkind

Kansas City MO While the emphasis last year in Denver was AM processing and NRSC, there was no doubt that FM processing issues have returned to the forefront of engineering discussion.

In fact, virtually all of the Thursday evening night owl session of the 1989 SBE National Convention in Kansas City was devoted to FM processing.

Chaired by Andy Laird, of KDAY, Los Angeles, there was a good interchange between the panel and the standing, sitting and kneeling room only audience of about 150.

Although the SBE apparently did not expect so many to attend, most stayed for the entire session and likely more would have attended if they could have gotten in the room.

Chris Hicks, of Valley People, spoke about the status of digital processors, and John Bissett, of Delta Electronics, had an update on the NRSC FM Committee.

Then the discussion turned to FM processing.

Clipping and modulation

While the Modulation Sciences' new ModMinder was not mentioned by name for 90 minutes, the discussion and slide presentations by Greg Ogonowski, of Modulation Index and Frank Foti of

. . . excessive clipping was creating . . . a multipath-like sound

Cutting Edge Technologies, focused on reducing problems that force a station to reduce modulation.

Ogonowski chose to center attention on overshoot in various components in the audio chain, including the STL and exciter.

With slides of several STL units and state-of-the-art exciters, he showed how an equalization network can regain peak modulation lost to protecting against the overshoots. In some audio chains, as much as 15% peak variation was possible.

Foti also is approaching the problem from the overshoot angle, calling it the "greatest robber of loudness." His answer is a new Cutting Edge product called "Dividend".

"Dividend" is a composite filter designed both to reduce overshoot and provide a significantly cleaner SCA spectrum. With SCAs becoming a significant income factor for stations, the need to keep the upper bandwidth clean is becoming more important.

While the discussion centered on filtering and equalizing the composite signal, it was also acknowledged that excessive clipping was creating many problems, including a multipath-like sound in some cases.

While not at the session, there was no doubt that many were thinking of the current controversy over Eric Small's ModMinder and its approach to measuring modulation. Small contends that typical overshoot is not significant and can be safely ignored.

Small's approach, that peaks under 1

ms do not impact occupied bandwidth, can allow a station to increase modulation without increased processing. Minor clipping is shown to provide no advantage.

In the receiver

As to whether radios themselves were a distortion point, several individuals spoke about modulation war zones where 125% peak modulation, or more, was used without significant receiver problems.

More alarming, perhaps, were comments relating to manufacturers reacting

to the highly processed stations by already reducing the IF bandwidth in receivers, introducing distortion that way.

Another of the points covered was how excessively clipped audio not only spread garbage around the signal, but by reducing the S/N ratio around the 19 kHz pilot, could cause many newer radios to begin "blending" the station into mono, as reported with the newest receiver chips being tested today.

Sadly, the consensus appears to be that as long as it appears profitable to smash audio, it is inevitable that someone will push the limits further. With-

out local pressure for FCC enforcement, this will not change in the near future.

Other questions that were considered during the session included the optimal number of bands in a multi-band processor, use of phase scramblers and a couple of fixes for older processors out in the field.

There was even a question on AM processing, relating to matrix processing for AM stereo, but all in all, this was a year for discussing FM processing.

■ ■ ■

Barry Mishkind is RW's Eclectic Engineer and can be reached at 602-296-3797.

WINNING



COMBINATION

Distribution amps, at best, give you one or two inputs, up to eight outputs per channel and everything is hard wired. If your signal routing requirements change, as they often do, you're in for a major re-wiring job.

Unlocking the Possibilities.

With eight inputs and twenty-eight outputs, our Routing Distribution Amplifier is light years ahead of the pack. Because any input, or combination of inputs, can be easily distributed to any output, or combination of outputs, the RDA is justifiably a winner.

But the advantages don't stop there. Changing signal

routing paths is simple. All you do is open the front panel, shift a few Berg jumpers and you're done. Level controls for each output are located adjacent to the selection jumpers.

Unequaled Audio Quality.

With a signal-to-noise ratio of 98dB below the clipping threshold, the RDA gives you exactly what you're looking for—transparency. Plus, the RDA's exclusive Optimum

Level Control ensures the best compromise between headroom and signal-to-noise ratio.

Coarse matching the input level with four position dip switches and fine tuning with trimmer adjustment is visually aided with bi-color LEDs. The green light tells you that the RDA is operating at optimum level and the red light shows you that maximum level has been reached.

One More Critical Input.

To find out more about the most versatile distribution amp in the business, route your input to your Gentner distributor or give us a call.



GENTNER
AUDIO PRODUCTS

1825 Research Way • Salt Lake City, UT 84119 • (801) 975-7200 • FAX (801) 977-0087

©1989-Gentner Electronics Corporation

World Radio History Circle 88 On Reader Service Card

Format Sentry™

“Simply the best value in Broadcast Automation”

Greg Smith
Owner of 1st, 2nd
and 129th System

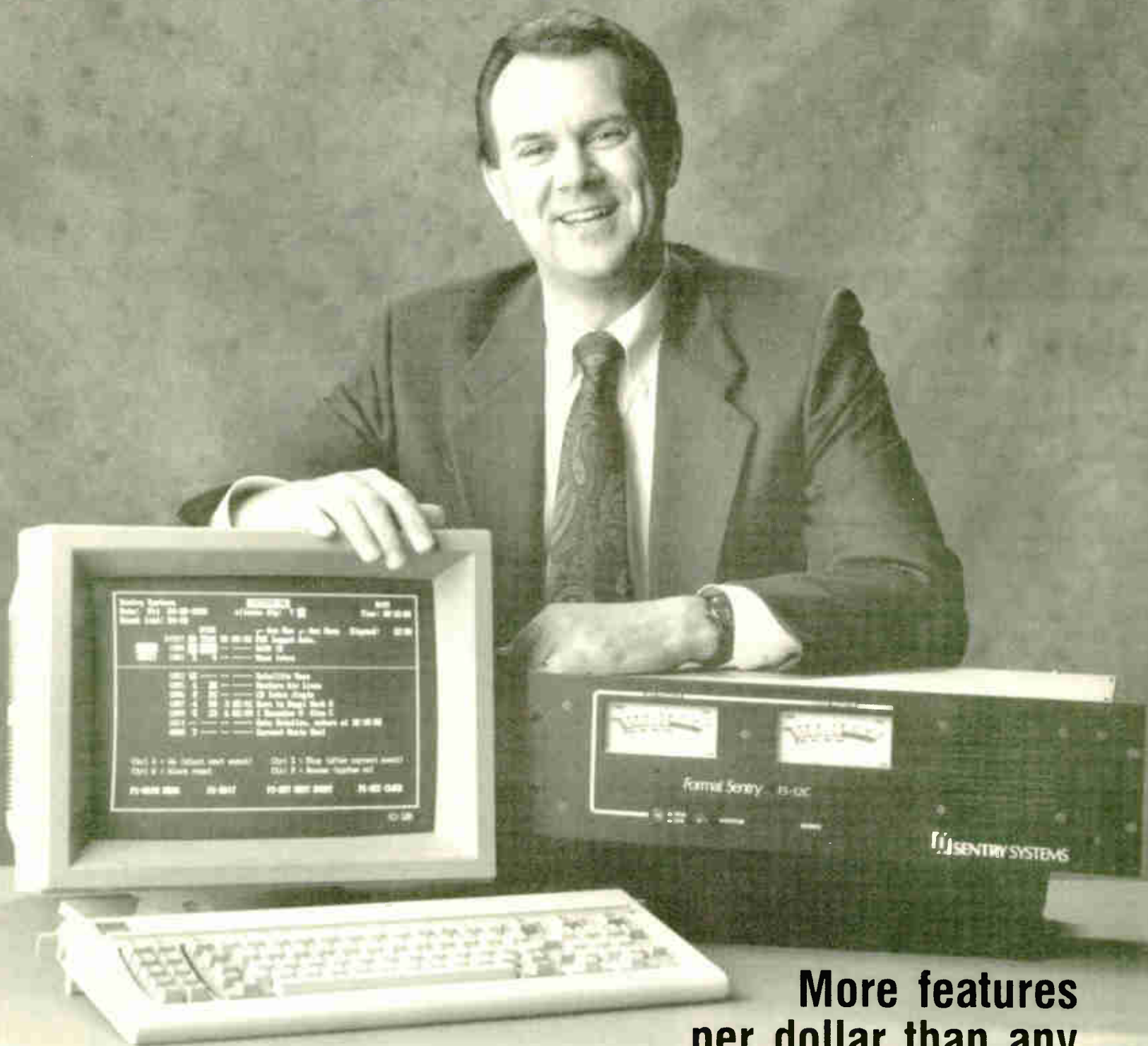

**More features
per dollar than any
other Automation Controller**

ALLIED
BROADCAST SYSTEMS
— A HARRIS COMPANY —

CALL (714) 752-6664
IN CANADA CALL 800-268-6817

World Radio History
Circle 52 On Reader Service Card

State Licensing Elicits Debate

by Tom Osenkowsky

Kansas City MO Over the past 18 months there has been growing concern among broadcast engineers over the attempt by various states to regulate their business activities.

A nightowl session at the national SBE convention here in October addressed the issue and proved that the controversy is far from over.

To date the SBE and NARTE have adopted general policy statements addressing the concern of their respective memberships, while AFCCE is in the process of drafting a posture statement.

The presiding panel consisted of former SBE VP Bob Van Buhler; Dane Erickson, PE of Hammet & Edison; Chris Imlay, legal counsel for the SBE; and Karl Lahm, PE of Lahm, Suffa and Cavell.

The nightowl session was clearly an emotional one. SBE is apparently in the process of reconsidering its title of Professional Broadcast Engineer—the highest certification level.

Pro or not?

Since the term "professional" appears in that title, it has generated concern by professional engineers (PEs) and those

. . . the greatest concerns . . . had their roots in semantics.

who have achieved the SBE certification.

Two PEs present at the session voiced the opinion that they have deservedly earned the Professional Broadcast Engineer accreditation and that all three words accurately describe what they do and what they are.

The suggestion of an alternate title, such as "Master Broadcast Engineer" was not well received. Some audience members felt threatened by additional state regulation, especially those who have been practicing broadcast engineering for many years.

Lahm pointed out that if PE registration were required to perform the functions of broadcast engineering, consulting engineers who perform such tasks nationwide would be subject to registration fees in each individual state.

Legislation varies from state to state as do the requirements for attaining PE registration.

Question of semantics

Probably the greatest concerns voiced at the session, however, had their roots in semantics.

The term "engineer" may only be used by PEs under strict interpretation of the law in many states. This contrasts with both SBE and NARTE policy statements as well as the long established use of that term by broadcast and telecommunications technical personnel.

NARTE is placing the main thrust of its efforts at the federal level, aiming for federal preemption of regulation for radio and telecommunications engineers.

While SBE is working on a case-by-case basis, its present policy is, in the opinion of some, somewhat weak on protecting engineers who hold themselves for

general hire in the broadcast industry, such as "contract engineers."

Specifically, it came to light that the SBE policy statement does not protect the term "consulting engineer," which accurately describes the work performed routinely by many, especially in the RF area.

The NARTE policy, on the other hand, appears to favor the inclusion of this term for federal preemption.

Dispute over ad

Mike Patton, president of Patton Circuit Systems in Louisiana, voiced concern over his state's action requiring him

to remove a Yellow Pages ad because the term "engineer" was displayed.

Louisiana requires a non-degreed individual to have at least 20 years experience as substitution in order to qualify for the PE exam.

Such stringent requirements may place a burden on individuals employed in an industry which up until recently has been free of state regulation, Patton pointed out.

The July/August issue of NARTE's newsletter also illustrated a number of specific cases where the state licensing controversy has flared. NARTE main-

tained that in all cases the defendant has prevailed, but at costs ranging up to \$21,000 in legal fees.

SBE members concerned about the issue were encouraged to write the national SBE office to make their views known.

Those present were also urged to write individual congressional representatives in support of a bill which would step into the fray and attempt to resolve the problem for broadcast engineers.

■ ■ ■

Tom Osenkowsky is a consulting engineer in Brookfield, CT and a contributor to RW. He can be reached at 203-775-3060.

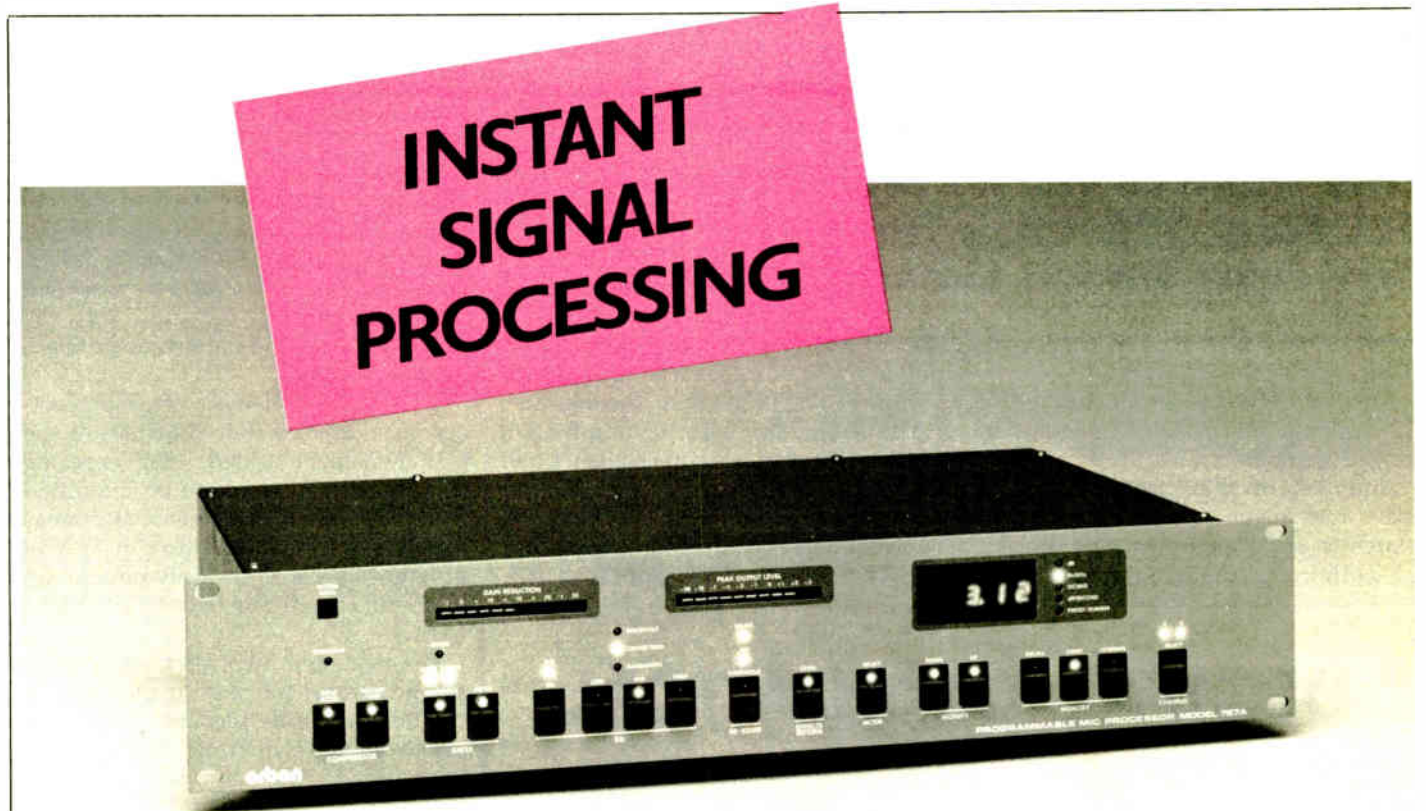

Orban's new digitally-controlled 787A Programmable Mic Processor integrates an unprecedented combination of vital signal processing functions into one powerful, compact package. It delivers fully programmable **mic- or line-level** processing with access to 99 memory registers through MIDI or RS-232 interfaces, or a console-mounted remote control. All you do is add the talent.

The 787A offers a space-saving, elegant solution to many annoying problems (voice or instrumental deficiencies, poor room acoustics, noise, sibilance, wandering levels) in multi-track and MIDI recording studios, commercial production, video post, audio-for-video, and film scoring facilities. The 787A increases production efficiency through consistently repeatable processing. Less time need be spent tweaking separate processors, so more attention can be devoted to capturing top creative performances as they happen.

The 787A is complete audio processing arsenal in a box—a flexible parametric EQ, a smooth compressor, noise and compressor gates, and a handy de-esser. The 787A can be operated in mono or dual-channel/stereo (with the addition of a second-channel slave). An optional Jensen transformer mic preamp with 48V phantom power adds further flexibility.

Orban's 787A Programmable Mic Processor will help you remember tomorrow the way your talent sounded yesterday.

Orban a division of AKG Acoustics, Inc.,
645 Bryant Street,
San Francisco, CA 94107 USA
(415) 957-1067 Telex: 17-1480
FAX: (415) 957-1070

orban

Class A Upgrade List Due Soon

FCC Plans to Disclose Which 500 FM Stations Are Eligible for Boost

by Charles Taylor

Washington DC Class A station owners hoping that they are among the 500 FMs eligible for an FCC-approved power boost declared in July, will know their status when the Commission publishes a list of approved stations toward the end of this month.

The anxiously awaited rule selectively allowed about 500 stations judged fully spaced to boost their maximum effective radiated power from 3 kW to 6 kW after

up to 25 kW with an antenna height above average terrain of 328'.

Those applications are pending with the Commission.

File forms carefully

Any of the stations eligible either for an upgrade or for consideration of one need to follow closely what is expected of them in order to process any possible change in power, said Karl Kensinger, FCC chief of allocations.

"It's a highly technical area, which understandably, people get confused about," he noted.

Each of the 500 fully spaced stations cited in the upcoming November list to be published by the Commission will be required to file FCC Form 302, "Applica-

"Application for Construction Permit for Commercial Broadcast Station."

Meanwhile, 1400 Class A stations are likely eligible for an upgrade on a case-by-case basis, including 800 stations that do not meet new distance separation requirements; and 600 that border Canada and Mexico.

These stations are eligible 1 December to file FCC Form 301, which requests detailed information about a station's legal and financial qualifications, program service statement, an integration statement, engineering data and antenna and site information and equal opportunity programs.

Class C3 upgrading

For stations interested in upgrading to the new Class C3, the first step was responding in writing by 7 August to the FCC's notification of eligibility. According to Kensinger, each of the stations was sent a copy in April of the Notice of Proposed Rule Making, which contained a list of the 149 proposed upgrades.

About 75% of the stations responded, he said.

"It was a surprisingly small percentage that decided they didn't want the C3," Kensinger added. "We expected that those who wouldn't be interested would be stations in Alaska and areas like that where it wouldn't make any difference because the only population they could serve was right by the transmitter."

The next step involves the Commission's perusal of any comments or counter proposals filed against a particular station's upgrade. Each potential upgrade was assigned a docket number.

Then, "we'll look at each individual docket and issue a Report and Order on each docket, and that lets them know what the decision is," he said.

Those stations must then—like their

other upgrading Class A counterparts—file Form 301 for a construction permit.

For information, contact Karl Kensinger at 202-634-6530; or Bob Greenberg 202-632-6909.

DEA Clears Root of Drug Allegations

Washington DC An investigation by the US Drug Enforcement Administration against former Sunrise Management Services attorney Thomas Root has been closed, clearing the communications attorney of possible drug-related charges.

Root, who represented organized investor partnerships for Sunrise before the FCC, gained fame after being rescued from a mysterious plane crash in the Caribbean in July.

He was being investigated by the drug enforcement agency after an airplane he owns was raided and turned up 28 loaded firearms and a can of ether, sometimes used to refine cocaine.

The only charge to come out of the probe was a \$100 fine for failing to register a Mac-11 machine gun. Root told officials that he is a gun collector.

But Root isn't off the hook yet. Investigations continue by the Federal Aviation Administration, the National Transportation Safety Board, the FBI and a Washington federal grand jury. He also has been sued by Sunrise Management for allegedly embezzling company funds.

(The stations) will be required to file FCC Form 302, "Application for New Broadcast Station License."

filing necessary FCC forms.

Another 1500 Class A's are qualified for the upgrade on a case-by-case basis after 1 December.

And close on their heels are stations that were given the opportunity in March to apply as a new station class, C3, authorizing them to transmit using

tion for New Broadcast Station License," within 10 days of initiating the upgrade.

The short form asks for information regarding power, antenna statistics and transmission and, according to FCC supervisory engineer Bob Greenberg, circumvents the customary and more burdensome process of filling out Form 301,

DIGITAL DEDICATION.

The Sony PCM-3202 digital audio recorder allows you to maintain the digital integrity of your source material while providing splice-editing capability at a most affordable price.

To find out more, contact the Sony Professional Audio Office nearest you:
East: (201) 368-5185
West: (818) 841-8711
South: (615) 883-8140
Central: (312) 773-6001

PCM-3202

- TWIN-DASH 1/4" two-channel digital format • Up to 95 minutes recording (12.5" reel, at 48kHz) • 16-bit microprocessor to manage tape transport functions • Built-in splicing block
- Switchable 48kHz and 44.1kHz sampling frequencies • AES/EBU and SDIF-2 digital I/O ports • Built-in monitor speaker and headphone amp • Built-in 10-key locator

SONY

PROFESSIONAL AUDIO

Sony Communications Products Company,
1600 Queen Anne Rd., Teaneck, N.J. 07666
© 1989 Sony Corporation of America,
Sony is a registered trademark of Sony

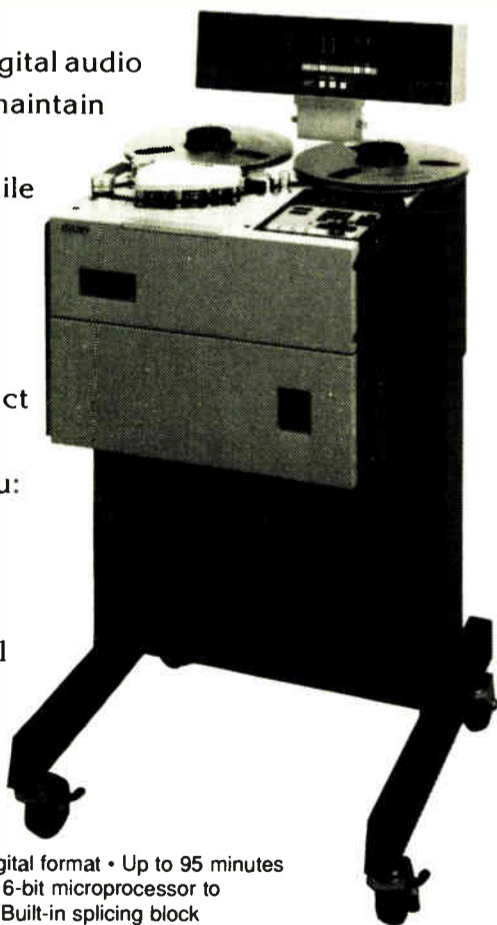

POWER...

60,000 WATTS

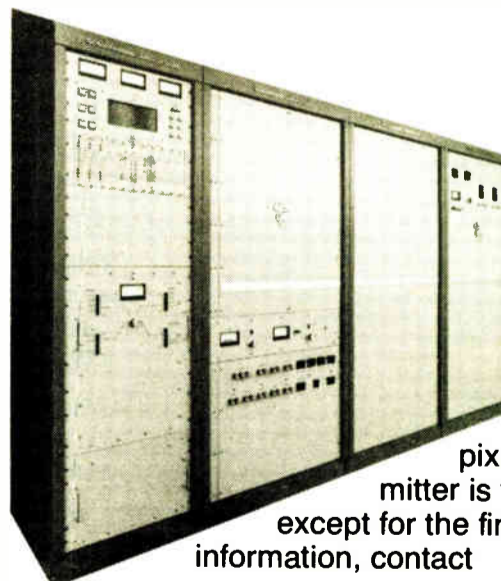

The 817A has a single output of 60kW and is totally self contained. An internal viewing screen provides seven screens on a pixel display. This transmitter is totally solid-state except for the final PA tube. For more information, contact

varian®

continental electronics division

P.O. BOX 270879 DALLAS, TEXAS 75227 (214) 381-7161 FAX NUMBER (214) 381-4949



Earthquake Plunges SF Into Radio Silence

(continued from page 12)

KCBS-AM and KRQR-FM, CBS O&Os in San Francisco, were operational with no tower damage, according to CBS Radio Media Relations Manager Mindy Gansley in New York.

At KCBS there was a brief outage and KRQR simulcast with KCBS from 7 PM to midnight then went on its own.

At the California Broadcasters Association, Biondi praised the efforts of radio and TV stations for disseminating information to an otherwise communication gridlocked area.

As it is doing for stations in South Carolina damaged by Hurricane Hugo, the NAB is acting as a clearinghouse to coordinate equipment purchases for California broadcasters.

For assistance from the NAB, call 202-429-5346.

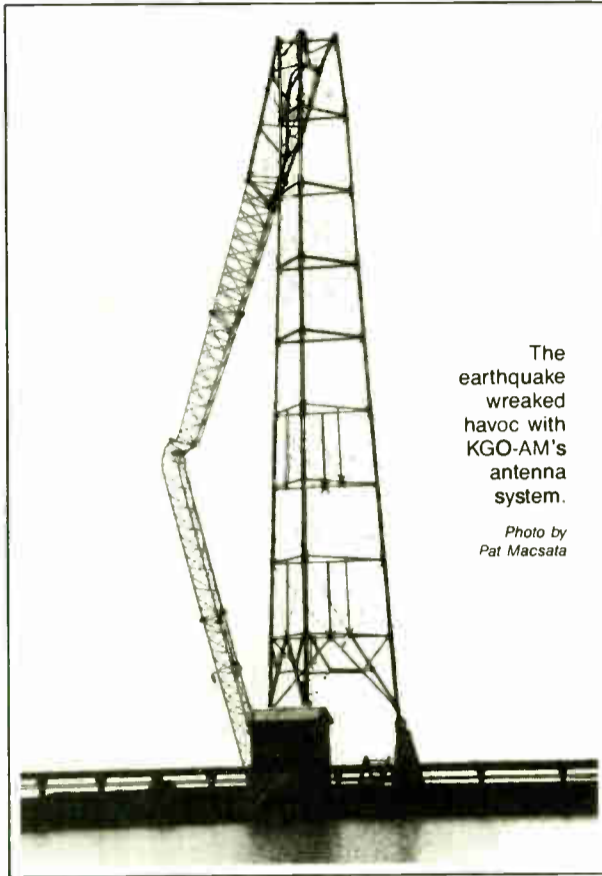

The earthquake wreaked havoc with KGO-AM's antenna system.

Photo by Pat Macsata

Hugo Relief Efforts

(continued from page 12)

were devastated. The efforts to assist the situation have been overwhelmingly positive, according to Janet Elliott, director of operations with the Science & Technology department. Between 35 and 40 broadcasters nationwide have phoned the organization to offer assistance, she said.

Equipment offers

"We've gotten a lot of calls from broadcasters interested in exchanging equipment with people in South Carolina and in Puerto Rico and the Virgin Islands," Elliott said. "In some cases, people are

willing to loan equipment or give discounted prices."

To spread the word following Hugo's destruction, NAB contacted broadcasters nationwide through releases to the press, its own publications, the Associated Press news wire and over Tele-Journal.

"We're still sending the message out," Elliott said. "We're trying to act as a resource between the two parties: those who know the status of the equipment and the people who are in South Carolina who know what is damaged and what they need."

For information on the NAB's clearinghouse, contact Janet Elliott at 202-429-5350.

Great Sounds From Great Cartridges

ARISTOCART

Superb in Quality
Supreme in Economy

SPACE SAVER UNITS

Aristocart's compact racks are simple, lightweight, rugged and ready to wall mount.

Model AW-20, holds 20 cartridges ▶

Model CD-40, holds 40 discs ▶

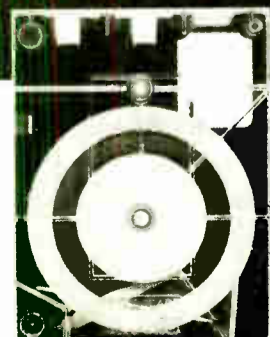

Place your order today or Call, Write or Telex for descriptive literature



Western International Communications Ltd.
17 - 825 McBride Boulevard, New Westminster, B.C. V3L 5B5
TELEPHONE (604) 526-3214 TELEX: 04-34639

The RPU Of The Future



Available Today

TFT has responded to the needs of today's broadcasters by introducing the Model 8888 RPU System that offers outstanding flexibility, versatility and reliability. The transmitter and receiver are frequency synthesized for maximum versatility in the N1, N2 and S bands. Two operating frequencies are programmed by internal DIP switches and are front panel selectable. In addition, frequency deviation and receiver bandwidth are selectable. DTMF control is provided for receiver activation, bandwidth and deviation selection. The 8888 enables you to change the RF power output via a rear panel switch to suit your needs. Maximum output power is 25 watts. Model 8888 Transmitter, Mfg. list \$2,260.00 Model 8889 Receiver (not pictured), Mfg. list \$1,710.00 Call for BSW Price.

BSW

BROADCAST SUPPLY WEST

America's Full-Time Broadcast Supplier

1-800-426-8434

ORDERS • INFORMATION • SPECIFICATIONS
BSW • 7012 27th Street W • Tacoma, WA 98466 • FAX 206-565-8114

Riding Out Hugo's Onslaught

by Buddy Womack

Myrtle Beach SC We all watched and plotted the path of Hurricane Hugo, all the while hoping it would not make landfall here at Myrtle Beach. Although we didn't get hit directly, as did Charleston, we did get nearly full force winds as well as a tidal surge that wreaked havoc on the Grand Strand's coastline.

As the CE for Power 98, it was up to me to keep us on the air as long as possible, so that we might inform the public of the conditions at hand. This was a much larger task than I had ever anticipated. I had no idea of the destructive force that was about to unleash itself upon us.

Preparations

Hugo was supposed to make landfall around midnight Thursday, 21 September. We ordered a 100 kW generator, which had to be shipped in from Pennsylvania, to keep power flowing to our QEI FMQ 30,000 transmitter. We also ordered a 35 kW generator for our studio located in Myrtle Beach.

Our transmitter is located about 15 miles south of our studio, so we needed the reliability of the 100 kW unit. A call was placed to Mancill Electric Company, a local firm at the beach, to hook up the two generators. As one would expect, they were very busy with other similar requests, but they assured us they would

get the job done.

Greg Hotchkiss was the electrician who did the job, and what a job he did. At 8:30 PM Thursday the 100 kW unit arrived at our transmitter site. By this time the wind and rain was getting pretty bad, but Greg forged ahead, getting the unit wired into our main panel box.

After the unit was wired in, we checked the rotation of the QEI's blower to insure correct phase hook-up. All seemed OK, so we brought the transmitter on line. Everything looked good at the transmitter site at this point and we headed back to the studio in Myrtle Beach.

This unit was a little more difficult to hook up because our studio operates on a split main system. We decided to pull the meter from the meter base and hook into the load side to feed the two separate systems. This worked very well.

We finished the hook-up at 11:15 PM, approximately 1 to 2 hours before the main surge was to hit us. Even at this time we had winds around 50 miles per hour and the rain was pouring down.

Everything went fine at our transmitter site, although the generator at the studio caused problems all during its usage. The voltage control circuit was intermittent and the voltage would drop off to zero without warning.

I spent the night beating the card cage on the generator in order to keep it working. I told our PD Barry

Richards, who knew what I was doing, that it just needed a "slight engineering adjustment."

EBS of no help

We remained on the air during the entire hurricane and got messages out to the public. Just getting any information was nearly impossible. The Civil Defense and government officials would not give us any information and the EBS was never even used.

The latter just goes to show that the EBS is useless, as many broadcasters have expressed. I think some serious attention should be given to revamping the EBS. The idea may be great, but the system itself does not work!

The Governor of South Carolina even had to get the operator to break into a live phone conversation on the air so he could call us and broadcast a message to the people of our area. I guess even he knows the EBS won't work because he didn't use it.

As daybreak came and the awesome destruction of Hugo was realized, calls began pouring into our studios. Some were used on the air and some were handled through the office switchboard.

It was apparent that people had stayed with us all through the night and appreciated the efforts we had made to remain on the air. We all felt as if we had been a part of what radio is really all about... serving the public.

As things started getting back to some form of normalcy, we got off the generators and our power was restored. We called the people we got the 100 kW unit from and told them we were through with it so they could come get it. Later that day, which was Wednesday, 27 September, the sound that engineers hate to



Ripped awnings at Power 98 were the aftermath of Hugo's wrath.

hear the most was on 97.7 MHz. It was the sound of a transmitter off the air! Static!

I jumped in the 4x4 and headed for the transmitter site. I arrived there just in time to see that a truck had hit a power pole, knocked out our power and my 100 kW generator was going down the road behind a wrecker dispatched from Charlotte, North Carolina.

As I stood there, powerless, I thought it ironic that Power 98 stood up to the fury of Hurricane Hugo, but was knocked off the air by a truck!

It just goes to show that the forces of nature may not be the cause of our greatest fears after all.

■■■
Buddy Womack is corporate CE of Bresson-Hafler Media Group. He can be reached at: 803-236-5115.

Sansui's Spectacular CD



Northeast Broadcast Lab brings you the CD-X711, featuring Sansui's exclusive LDCS 1-bit DAC audio circuitry for DC to 20kHz frequency response, THD at 1kHz no more than 0.003% and a signal-to-noise ratio of 103dB.

Optical, digital and XLR-type balanced audio outputs and vibration-isolating design make this the perfect CD player for your studio.

Invest in this Sansui CD! contact your nearest Northeast office.

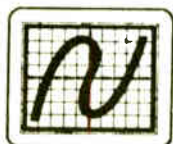

NORTHEAST BROADCAST LAB, INC.

MAIN OFFICE
P.O. Box 1179
S. GLENS FALLS, NY 12803
Tel: 518-793-2181
Fax: 518-793-7423

MID-ATLANTIC
P.O. Box 565
SOUTHAMPTON, PA 18966
Tel: 215-322-2227
Fax: 215-953-0523

NEW ENGLAND
P.O. Box 406
AUBURN, NH 03032
Tel: 603-483-1002
Fax: 603-483-2352

Circle 60 On Reader Service Card



You
can measure...

with the best monitor and the most accurate test set.

The FMM-2/FMS-2 series monitors provide an even greater degree of precision measurement than ever before... You can measure S/N below 90 dB, You can measure crosstalk below 85 dB, You can measure separations of better than 70 dB, You can measure frequency response to better than 0.25 dB, You can measure distortions to lower than 0.01%, and much more... Our uncluttered panels and autoranging voltmeters make these measurements a dream.



BELAR CALL ARNO MEYER (215) 687-5550
ELECTRONICS LABORATORY, INC.

LANCASTER AVENUE AT DORSET, DEVON, PENNSYLVANIA 19333
Call or write for more information on Belar AM, FM, Stereo, SCA and TV monitors.

Circle 82 On Reader Service Card

Achieve Loudness with Quality

by John "Q" Shepler

Rockford IL It happens in the best of markets. Everyone is talking about signal quality. In NAB seminars and SBE meetings, engineers are feverishly taking notes on the latest techniques for reducing transmitter distortion.

Then, suddenly and unexpectedly, it happens. One station cranks up its processing and breaks away from the pack. Like a supernova, it dominates the band with audio power.

Reaction comes swiftly. In hastily called meetings, program directors rail against the new threat.

"We have to respond now," they say, "or the next book is lost."

The station managers become noticeably shaken and turn to their CEs.

"Can you do it? Can you beat 'em? We have to be at least as loud ... maybe louder."

You feel the blood drain from your face. This is panic, not logic. Quickly, you raise the arguments about audience burnout and competition from auto cassettes and home CD systems. It doesn't matter, their minds are made up. The signal has to be loud ... louder ... loudest. After all, this is *war!*

Quality and loudness

One thing you should know is that quality and loudness are not mutually exclusive. It is possible to have both. In fact, to have a truly dominant signal you must have both.

Q-TIPS

Quality and loudness are both relative terms. You are either louder or softer than the other stations on the dial. You either sound better or worse than those other stations. True, there are audiophiles who will A/B their tuners and CD players and say, "Yuucck! All of these stations sound hideous."

Don't let your feelings get hurt. These people are not your audience. Your real listeners have car radios with 5" speakers or \$15 Walkman-type radios that also play high-speed-duped tapes. If they are listening at home, it's on a clock radio or a den stereo with the volume maybe 10% up. They think those audiophiles are a little eccentric.

This, then, is the first secret of winning the loudness wars: You probably only have to sound better than the other stations on the majority of radios in your market.

Audio power

The most effective thing you can do to stand out on the dial is add power to your audio. Modulation monitors don't measure power. They measure peak amplitude or frequency deviation.

The nature of audio is to have high peaks and low average values (as shown in Figure 1). The mod monitor will read 100%, but a VU meter on the output of a receiver will read much lower.

You add power to your audio by reducing that span between the peak and average levels. Figure 2 shows such a signal. The mod monitor still reads 100%,

but the average audio level is much higher. This signal will sound a lot louder than the one in Figure 1.

So how do you add this power? With audio processing. Nearly all processors compress the signal, limit or clip off the peaks, or tinker with the tonal balance through equalization. Multiband processors do all of these things.

You add power by compressing deeper, 20 dB to 60 dB, speeding up the time constants to add density, chopping off the peaks to increase the average level without adding density and tailoring the frequency response to match the receiver's bandwidth. This puts the audio where it will do the most good.

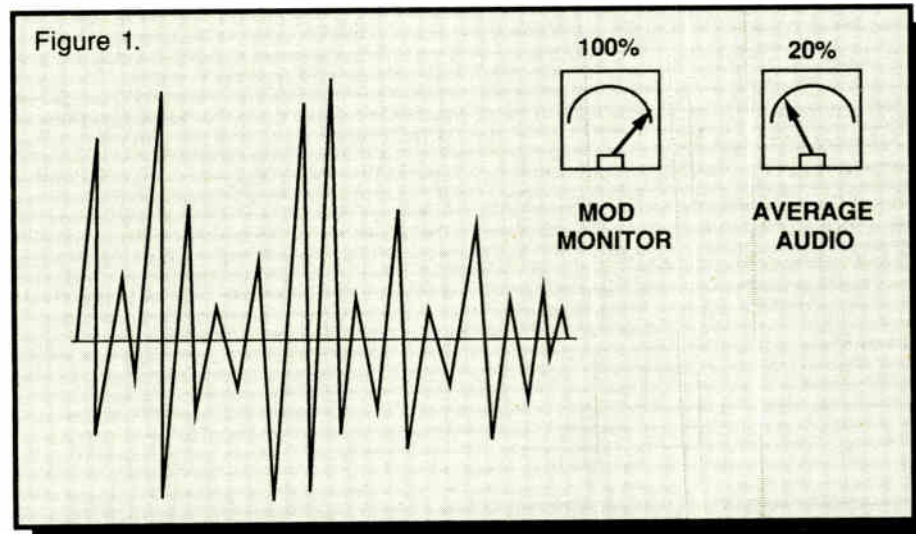

Some years ago, Mike Dorrough raised the loudness and quality of AM signals with his multiband DAP. By splitting the audio band into two or more segments, a much higher level of processing can be used before the signal turns to mush. Another feature of the DAP was diode peak clipping which provides a brick wall for modulation.

Bob Orban added loudness and quality to the FM band with the Optimod

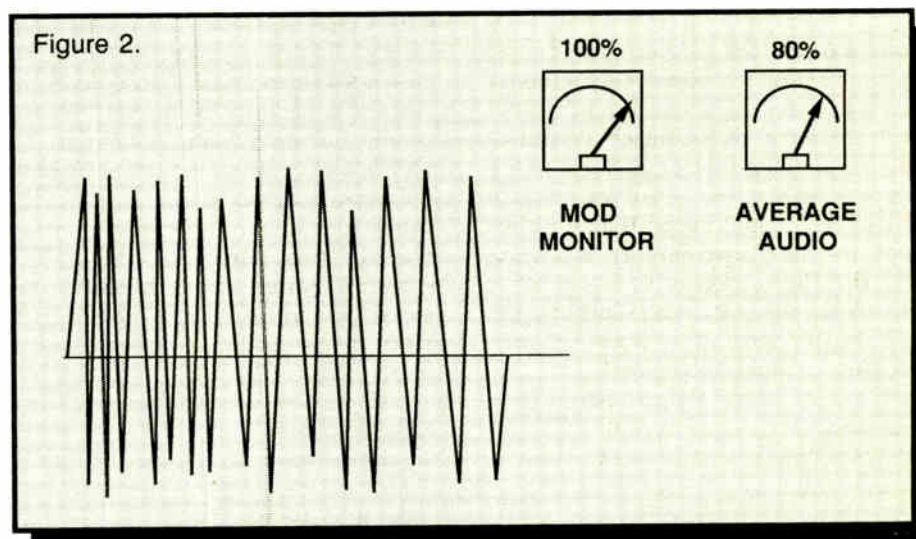

8000 processor. The key design feature was op-amp rather than LC low-pass filters. The cutoff filters are needed to prevent splatter into other channels.

What Orban did was design circuits with low overshoot so that modulation levels could be raised with no detriment to quality. This is a case where the modulation monitors were reading high peaks that had no relationship to the original audio.

Various manufacturers have addressed the problem of overshoot in transformer modulated AM transmitters by adding ring and tilt compensation to the processors. The processor counteracts the transmitter's tendency to overmodulate on peaks and thus allows higher audio levels with no quality loss.

Composite clipping of FM signals can provide a brick wall of modulation by chopping off the various overshoots of filters, stereo generators and STL links. Adding composite clipping, while reducing heavy compressing, can give you a louder and more open sound.

Some processors add even-order harmonics to brighten the signal. It's the odd harmonics and intermodulation distortion that sound offensive. At first glance, you might think that this is phony manipulation of the audio. However, where the ear is concerned, only the sound of the end result really counts.

Efforts versus effect

It's strange but true that most of your efforts to boost your audio will have only marginal effect. The 80/20 rule says that

(continued on page 38)

Perfect reception in long yardage situations.

Shure's new FP11 and FP12 field production units help the signal come through loud and clear. The compact size and ultra-rugged design of these units make them perfect for ENG, FFP film and even sound reinforcement situations. Lightweight, with belt clips, they'll go

FP12 Headphone Bridging Amp

The FP12 lets you check any audio line through headphones, without terminating the signal. The unit accepts standard 1/4" or 3.5 mm mini-plugs. Its 96 dB of gain drives headphones even with a weak signal.

FP11 Mic-to-Line Amplifier

The FP11 boosts mic signals to line level by up to 84 dB, giving a clear, static-free signal over long distances. It features a precision stepped gain control, a switchable limiter, and easy access to batteries for checking or replacement.

For more information on Shure's complete field production family, call or write Shure Brothers, Inc., 222 Hartrey Ave., Evanston, IL 60204, (312) 866-2553.



THE SOUND OF THE PROFESSIONALS...WORLDWIDE.

Radio at the Old Alma Mater

by George Riggins

Long Beach CA College radio has been a training ground for all facets of broadcasting and TV since radio's earliest days. In the 1927 Official Bulletin #2 of the Federal Radio Commission (not a complete station list), 14 college stations were listed. Of these stations, five are apparently still operating with the same calls as college stations.

The following five are all listed in 1922, 1927 and in 1989:

- WBAA-Purdue University
- WCAL-St. Olaf College (shared time with KUOM)
- WHA-University of Wisconsin
- WKAR-Michigan State University
- WOI-Iowa State University.

The earliest days

There were many more college and educational stations in the early days, but it is interesting to note that of the 14 listed in 1927 with temporary broadcast permits, only one or two stations changed call signs sometime between 1927 and the present. Two are now commercial stations and three calls have disappeared. All this on the AM band.

(Before I get angry calls, most college radio is now confined to the FM band. As for history, we are concerned primarily with what happened before the present day FM.)

Going back to 1922, there were 39 call signs listed as having been issued to educational institutions. Some of the call signs were issued to such places as Butte School of Telegraphy, Butte, MT (KFBB); Brown's Business College, Peoria, IL (WFAP); and Spanish American School of Radio Telegraphy, Ensenada, PR (WGAD).

One or two others such as WOC (World of Chiropractic) were clearly commercial endeavors, in all likelihood aimed at promoting a private trade school; these were not counted. Several of the schools and universities sold their stations to commercial enterprises in the early days while others evidently did not have sufficient interest at the top levels to continue the course.

One of the earliest stations, dating from 1922, was KFAE, State College of Washington, Pullman, WA. Although not listed in 1927, it became KWSC by 1929. The school now operates KWSU, KZUU-FM and KWSU-TV.

Another early station was WRM, University of Illinois at Urbana. This university station was listed in 1922 but does not show up in any of the 1927 listings I have acquired. By 1929 the call had been changed to WILL and now includes WILL-FM and WILL-TV.

The University of Kansas is yet another long remembered call from the early (1924) days of broadcasting. The first call issued to the University of

Kansas was KFKU. This call is now joined by KANU-FM. No TV for the University of Kansas.

The Stephens shuffle

Stephens College sold KFRU, their first station, to the St. Louis Star-Times in the mid to late 1930s, before the Star-Times had KXOK on the air in St. Louis.



An interesting point regarding KFRU was the complicated frequency swap that took place between KFRU, WOS, WGBF and KXOK.

As reported to me, three of the stations were sharing time on 630 and KXOK was at 1250. Because 630 was deemed a more desirable dial position, it was decided to move KXOK from 1250 to 630, and move the others to 1250.

The frequency shift took place at all four stations on the same night. The engineer who was sent to work on KFRU reports that he was able to get the KFRU transmitter to tune to the new frequency without too much difficulty. Yes, additional capacitance was needed in the crystal circuit, but he made "sign on" time with a little breathing room.

Of course, he had the obstacle course

of the young Stephens College students to worry about, but managed to get through the ordeal with no battle scars. The original WOS call vanished and became KWOS, located at Jefferson City, MO. WGBF, Evansville, IN is now 5 kW day and 1 kW night at 1280 kc.

As a side note to the KWOS story, in the early days of the station in Jefferson City, some of the programming originated via a remote line from the state prison. Perhaps some remember a song titled "If I Had The Wings of an Angel." The song was written by a person in prison and introduced during one of the remote broadcasts from the prison facility.

Experimental innovators

Another early educational station, credited with going on the air in 1919, was WHAA, State University of Iowa, located at Iowa City. The first listing I have published in 1922 and shows only the wavelength of 360 meters.

By 1929 the call had been changed to WSUI, 580 kc and 500 W of power. It is interesting to note the radio station license issued to The State University of Iowa on 14 April, 1932 was for an experimental license, W9XX.

The license was issued for a period of approximately eleven months, effective on 27 May, 1932 and expiring on 1 May, 1933. The new station was listed as being on the following frequencies (in kc): "2000-2100 with A-3 and Special Television." Power was specified as being 50 W.

The experimental station was located in the Electrical Engineering Building on campus. Data sent to me shows a very

(continued on next page)

Clean up **dirty** talk dirt cheap.

For some listeners, waiting for things "you can't say on the radio" is part of the fun. But with today's free-wheeling talk radio formats, controlling what actually goes out on the air is more essential than ever. Now Eventide's BD941 and 942 Broadcast Audio Delays are here to make effective obscenity protection more affordable than ever.

The stereo BD942 and mono BD941 give you six seconds of delay protection (or optionally, three, or even twelve). Yet they cost thousands less than Eventide's industry-standard BD980. You don't get the BD980's elegant *Catch Up* function or its other sophisticated features. But the BD941 and 942 have an easy, convenient and totally reliable system of their own.

OK, you're on the air, and someone's just opened his or her mouth a little too wide. Just hit the *Delete*

button to delete an obscenity, and you're instantly back in real time. The BD941 and 942 delays also have a set of relay contacts that close automatically when *Delete* is pressed. You can use the relay to start a cart or other device to fill the delay period. Then, after the delay period expires, the unit automatically switches back online for full delay protection. What could be simpler?

The full bandwidth audio performance of the BD941 and 942 is everything you'd expect from Eventide, the world leader in talk show delays. All at a price that makes talk cheaper than ever. How much cheaper? Talk to your broadcast distributor, or call Eventide for the good news.

Eventide
the next step



ONE ALSAN WAY • LITTLE FERRY, NJ 07643 • TEL: 201-641-1200 • FAX: 201-641-1640

Circle 65 On Reader Service Card

59 YEARS AGO

Right or Wrong ?

QUESTIONS

(1)—If a grid voltage, plate current curve be taken on any tube, with a high resistance in its plate circuit, it is very nearly a straight line and does not resemble the curve obtained on the same tube when there is no load in the plate circuit. This can be proved by scaling the two curves so that when plotted on the same graph the curves coincide at zero bias.

(2)—Since grid voltage, plate current curves are taken with no load in the plate circuit, and the operating grid bias is determined from these curves, and moreover, since the effective plate voltage is equal to the applied voltage in the plate circuit when there is no load impedance, it is obvious that the effective plate voltage determines what bias should be used when there is a high load resistance on the tube.

(3)—In all cases where a grid battery is used for biasing a tube the effective bias is equal to the voltage obtained with a voltmeter connected across the grid bias battery.

(4)—The grid bias at which the plate current is reduced to zero is determined just as much by the load resistance on the tube as by the voltage in the plate circuit and the amplification factor of the tube.

(5)—No matter how well a circuit is designed, each tube always amplifies one-half of the signal cycle more than it does the other, and this of course signifies wave form distortion. However, if there is an even number of amplifier tubes part of this distortion is eliminated by virtue of the fact that each tube inverts the phase of the signal.

ANSWERS

(1)—Wrong. If the two curves are plotted on the same graph and the currents obtained with the resistance load arrangement are multiplied by the ratio of the two currents at zero bias, the two curves nearly coincide throughout their extent. There is a slightly less curvature of the resistance curve, but not nearly as small as is commonly assumed.

(2)—Wrong. The extent of the curves is determined only by the applied voltage in the plate circuit and the amplification constant of the tube. The resistance in the load of the tube has nothing to do with it, for it determines only what the plate current is at any given bias. This does not mean that the grid bias in a resistance coupled circuit must be equal to that of a transformer coupled circuit. It may be less if the signal is not so great as to drive the grid positive at any part of the cycle.

(3)—Wrong. Indeed, it is true in no case, although in radio frequency amplifiers with a low resistance in the external grid circuit the two may be so nearly equal that no difference can be detected with the voltmeter. The reason why the meter does not give the true grid bias is that it draws current and thus changes the voltages. Only a vacuum tube voltmeter which draws no current will give the correct bias, and even this will, in some cases, upset the voltages by a small amount.

(4)—Wrong. Only two factors enter, the voltage in the plate circuit and the amplification constant. The load resistance has nothing to do with it. The plate current goes to zero at the same bias whether the plate load is zero or 5 megohms.

(5)—Right. The positive half of the cycle is always amplified more than the negative, provided that the grid never draws current and that there is no plate current saturation effects. Since the signal voltage phase is reversed by each stage, if there is an even number of stages the wave form distortion is minimized.

Editor's note: The **RW** of today and the **RW** of old, printed for a period of time in the 1920s and 1930s fortuitously share the same name.

Reprinted from Radio World, September 20, 1930.

College Broadcasting

(continued from previous page)

detailed floor plan of the studios and several diagrams and pictures of the "scanning disk" transmitter and receiver.

Yes, scanning disks actually worked and produced about as good a picture as the early post-WWII black and white receivers produced. As proof, Bell Telephone had a two-way TV demonstration at the San Diego Exposition in 1935 to show the feasibility of picture and sound over telephone lines.

(Fifty-four years later we have, in reality, come to that point of the future. Now we do the picture phone bit with fiber optic cable rather than with copper wire.)

The University of Wisconsin is credited with doing some of the early experimenting with voice and music over 9XM, which later became WHA. By some reports, Malcom Hansen and Professor Earle M. Terry were among the pioneers of 9XM-WHA.

Finding employment

Heard some interesting comments from Louisville on the night of 21 June, 1989 as my wife and I were traveling between Laurel and Meridian, MS at about 10 PM.

While scanning the dial, WHAS was one of the stronger signals heard. I did not hear the entire program, but it was evidently a roundtable discussion involving many of the GMs from Louisville's radio and TV stations. The subject under discussion was how to go about getting work at a TV or radio station. One of the GMs mentioned that al-

most all of the new hires at his station started on a part time basis, usually as the "gofer." I think that the reference was to those who became part of the sales and production side of the business, although I can see that this could also apply to technical personnel.

Starting pay was said to be at or near the minimum wage, with the opportunity to advance as skills were acquired. Although I did not get the entire program, it would seem that someone who had taken the time to get some formal classroom training would be able to advance faster than a person with no exposure to any part of the business.

Another comment concerned interns. I have heard comments from both sides of the aisle concerning interns. From personal experience, intern programs properly administered and monitored can be very useful and rewarding for all concerned.

Perhaps there are some thoughts about either method of gaining employment that should be put into print.

Aerial navigation

Has anyone else used the normal AM band for aerial navigation? In the years prior to WWII, almost all of the larger planes (DC-3, C-47, B-17) had a radio compass installed. One could do a good job of cross-country navigation using three stations for triangulation to get from point A to point B without following the low frequency ranges or light lines.

This system was not recommended for

(continued on page 49)

The Carts You Can Count On



From The Supplier You Can Count On

Demanding broadcasters around the world count on Audiopak broadcast cartridges for consistent response, dependable quality and outstanding reliability. High-performance tape formulations, superior coating processes and rugged, "no-maintenance" casing designs have made Audiopak the international standard. Why settle for other broadcast cartridges? Getting "workhorse" A-2s, "stereo" AA-3s or "digital-ready" AA-4s is as easy as picking up your phone.

BSW

BROADCAST SUPPLY WEST

America's Full-Time Broadcast Supplier

1-800-426-8434

ORDERS • INFORMATION • SPECIFICATIONS
BSW • 7012 27th Street W • Tacoma, WA 98466 • FAX 206-565-8114

Deflating an Overblown Ego

by Allan Roycroft

Honolulu HI Now and then a young budding technician gets on an ego trip and some of us oldies on the block come in for some unfair criticism.

Such was the case of a young DJ who had aspirations of being an engineer without much knowledge or intent to improve the situation by study.

Here is a tale of the results of his aspirations, with the names and call signs changed to protect us innocents.

I had been contract servicing this AM station on Kauai for a number of years. The owner, John, was a friendly type who was not above taking routes where a small savings could be made.

On the staff was this young ego stricken DJ—Pete—who told John that he could take over the engineering for a hundred dollars a month and do a better job.

Crisis time

All went well as expected for several weeks before the old Rust remote control stopped stepping and in spite of all attempts to repair it, it still refused to go "click click."

So Pete announced that all readings and log entries from then on would be his sole responsibility.

There were many weeks of sharp pencil log entries and a silent transmitter operating through the midnight to

dawn hours.

A few days later the only transmitter, an excellent Collins 21E suddenly went into very bad audio distortion at 4 PM on a Thursday.

Pete went to work at once and by midnight had decided that the problem was that there was no longer idle current showing on the modulator plate current readings.

Working almost around the clock until Saturday morning he made no progress; all components around the bias system were doubly checked, new modulator tubes were tried—all to no avail.

After being off the air for more than 40 hours John finally stepped in and said "Sorry Pete, we will have to call Big Al."

Calling in experience

My phone rang in Honolulu around 9 AM and by John's manner, I got the idea that he was really enjoying the situation as he had also had his share of Pete's "style."

John gave me a brief summary of events before handing the phone over to a defiant Pete.

In response to my questions he replied "Yes of course I tested the bias pots," ... "Yes of course I tested the bias resistor string," ... "Yes of course both modulators are lit up brightly," ... "Yes of course I tested the main B+ to each modulator plate resistance."

I asked for John and suggested that he meet me on the 11 AM plane.

From many years with the 21E and knowing that the 1200 volt bias supply voltage was quite critical and since, obviously, we had more volts than usual, I figured the only cause on this full-wave supply using 866 rectifiers could be shorted turns on the swinging choke.

Simple solution

I selected a smallish choke that would handle the current from the shop stock and then went into the back area where several transmitters, including a 21E were operating.

I opened the center rear door of this unit and checked out the bias wiring and a small ledge below, noting that the grounded wire from the choke formed a small loop.

I quickly closed the door hoping that the studio did not notice the ten second break in programming. I then made up short leads on the choke terminating in PeeWee clips, put it in my pocket and left for the airport.

John was at the Lihue airport to meet me and was just bubbling with curiosity. I said that once I was in front of his transmitter and announced that I was "going 'round the back for a look", he was to engage Pete in conversation to take his attention from me.

Sure enough, the 21E had no modu-

lator idle current—those modulator tubes were choked right off.

I gave John his cue and opened the rear center door. I put one finger in the grounding loop of wire on the choke, yanked it free and placed the choke out of my pocket on the ledge. Then I quickly clipped it into circuit and closed the door.

Once more in front of the rig, I pushed "Plate On" and ran the bias pots up to where each modulator had the required 200 mA of idle current.

Turning to John I said "OK, let's get that noon plane to Honolulu." He followed, very red in the face in his efforts to control his merriment while Pete called the studio for program.

On the way to the airport I warned John that the station, now playing fine, would shortly go off the air again for a few minutes.

John nearly exploded, "Didn't you finish the job?"

"Oh yes," I replied, "but Pete's curiosity will get the better of him".

Sure enough the station did go off for about five minutes causing John to nearly lose control of his car and sputter "that kid's got to go."

It may have been a sneaky thing to do, but I have helped and am still helping dozens of budding young engineers get their acts together. But Pete was something else and in John's words, that kid had to go.

...

Alan Roycroft is president of Broadcast Services Inc. and a consultant to KIPA, Honolulu. He can be reached at 808-935-6858.

No Fat! No Cholesterol!

Slim Down with The News Director

by Sine Systems

A complete, easy-to-install, flexible and user friendly audio workstation. Controls up to 16 sources. Designed to be the central control device in news gathering and editing control rooms.

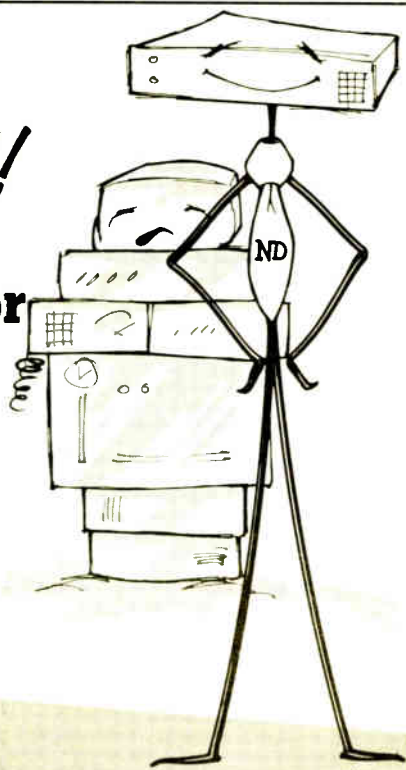

Saves time.
Simplifies news editing tasks!
Weigh the difference! Call for a demonstration today.



BROADCASTERS GENERAL STORE

HOME OFFICE
2480 S.E. 52nd Street
Ocala, FL 32671
(904) 622-9058

REGIONAL OFFICES
Illinois (708) 231-7120
Georgia (404) 425-0630
Texas (817) 275-1380

Circle 70 On Reader Service Card

Make the Right Switch...

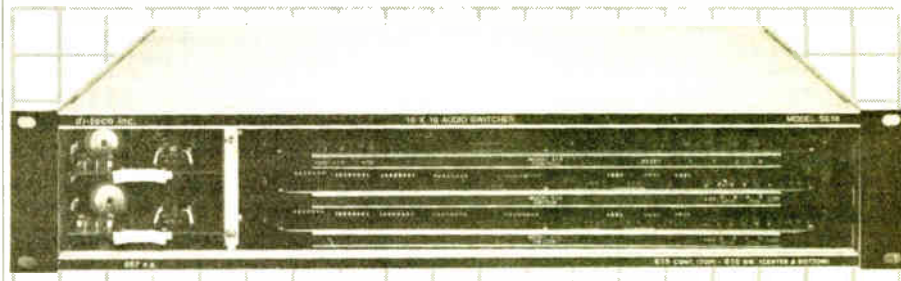

With The Compact (2 RU) Audio Only
Routing Switcher from di-tech

MODEL 5616 STANDARD FEATURES

- 16 x 16 Stereo
- 16 x 32 Mono
- Plug-in P.C. Cards
- Serial Coax for External Control Panels
- Output Level +24 dBu @ 150 Ohm
- RS232 / RS422 Computer Control
- All I.C.'s are Socketed for easy maintenance

ALL FOR A
COMPACT PRICE
\$5250

di-tech

48 Jefryn Boulevard, Deer Park, N.Y. 11729
Tel: (516) 667-6300 • Fax: (516) 595-1012

Circle 36 On Reader Service Card

The End of an SCA Tradition

by Tim McCartney

Boise ID A tradition is falling apart in FM. The 67 and 92 kHz SCA frequencies are bowing to experimentation with 76 kHz. And the change represents progress.

Although the FCC does not require that these particular frequencies be used, the industry has standardized and tested them over the years.

Why would a proven technology be passed over in favor of an untested combination of frequencies which might compromise the main channel stereo

kHz. The -3dB point falls at ± 9.2 kHz, -6dB at ± 13.8 kHz, and -50dB at ± 23 kHz.

The filter specifications were then used for development of two prototype SCA receivers by Johnson Electronics and McMartin Industries.

Modulation generator

Circuit Research Labs used the filter design to modify KBSU's 300-B SCA modulation generator. CRL broadened the experiment in the lab by creating, to the extent possible, actual field operating conditions.

The engineers at CRL fed the SCA signal into an FM exciter tuned to KBSU's main carrier frequency and listened on both the Johnson and McMartin SCA receivers.

CRL reported excellent results: audio quality superior to the traditional SCA system, with a sound much like the NRSC 10 kHz AM standard. They cautioned that its performance was actually closer to a 7 kHz audio system when considering fringe area SCA users.

After KBSU installed the new and modified equipment in its permanent home, field tests began (see Figure 2).

The frequency response, as shown in Figure 3 is flat (± 2 dB) from 50-7000 Hz, with a 5 dB rolloff by 10 kHz. Distortion at 400 Hz is 1.2%, the SNR is -40dB and it sounds great!

So far, there has been no noticeable impact on main channel programming and no listener complaints.

More tests remain on the SCA receivers themselves, to determine which model is the better performer.

The ability to provide special, high-quality monaural programming to either of KBSU's satellite repeater stations was

(continued on page 34)

The new location is effective in controlling main channel interference . . .

program? Two problems are behind the new direction.

First of all, SCA has a persistent reputation for "birdies," varying high-pitched whistles heard in some older stereo receivers during SCA operation.

The problem has decreased since the early 1970s when consumer stereo receiver manufacturers began using the integrated circuitry phase locked loop (PLL) stereo decoder. But, since "birdies" still appear occasionally, some stations remain hesitant to use their SCA channels.

The other problem is the poor audio performance of the 87 kHz SCA—limited to a 5 kHz audio bandwidth.

Thus, if "birdies" could be removed and fidelity increased, SCA would certainly be a revitalized medium, particularly in view of its many potential uses.

An NAB paper in 1987 by James Paffenbarger of WUOM, University of Michigan, documented his station's on-air experimental research with 76 kHz SCA.

The findings showed 76 kHz to be the most ideal frequency within the FM baseband for SCA use. The new location is effective in controlling main channel interference, such as birdies.

While the center frequency was moved, the experiment at WUOM incorporated the traditional 5 kHz audio response circuitry.

Better response

In a separate project, KBSU at Boise State University required a network which would be able to feed a second program service to its satellite repeater stations. A high-fidelity audio SCA service would provide such a capability.

SCA experts agree that a sub-channel centered at 76 kHz can pass an audio frequency response up to 10 kHz, with less than 3% distortion and no main channel interference.

Several companies agreed to the custom SCA project, but required a newly designed filter (see Figure 1 for the FM baseband plan).

QEI Corporation was just starting to build KBSU's new 691 FM Monitor/Test Set when its engineers were asked to design the 76 kHz bandpass filter. They agreed.

The QEI-selected gaussian 2-6 dB filter incorporates 150 μ sec preemphasis, centers at 76 kHz and is -60dB by 53

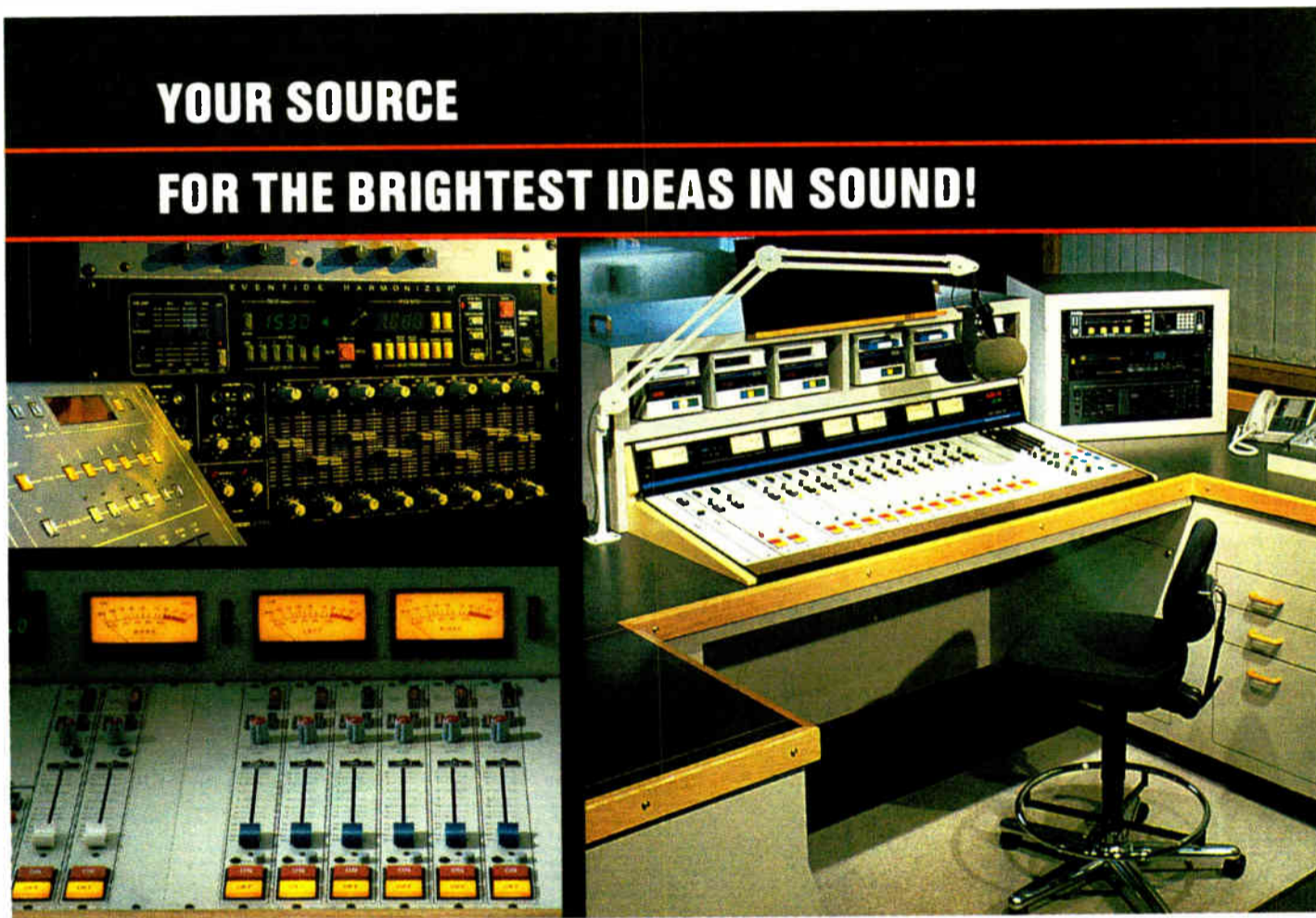

Audio offers a complete range of the finest equipment.

High-quality Studio Furniture from Audio.

Leading broadcasters rely on the Audio Broadcast Group for business building ideas in sound for three solid reasons: service, solutions and systems.

SERVICE

Nobody but nobody out services Audio. From initial project design to installation to post project evaluation we make service the rule rather than the exception. And as a full-service source we can provide a single component or turnkey service on complex RF installations.

SOLUTIONS

The ideas we develop are designed to solve your most perplexing problems. We couple the world's finest

equipment and our own specially designed Studio Furniture line to create solutions that look and work beautifully.

SYSTEMS

Because we manufacture a complete range of sophisticated studio furniture we can create the ideal custom system for you integrating our standard com-

ponents to save you money. Match our full-line of broadcast equipment and furniture for the ultimate in sound performance and value.

For more information or a FREE catalog write: Audio Broadcast Group, Inc., 2342 S. Division Avenue, Grand Rapids, MI 49507-3087 or call (616) 452-1596 for information or 1-800-999-9281 to order.

Rolling Radio,[™] a complete broadcast-ready mobile studio you can take anywhere.



The AUDIO
broadcast group inc.

Circle 43 On Reader Service Card

World Radio History

NEW NEW NEW

SERIES CONSOLES

S - \$6,499 /18 CHANNELS - \$8,893

FEATURES

- Totally Modular Console-Input modules, Output modules, Option modules
 - Ease of Service
 - Ease of Installation
 - Ease of Expansion
- Three Mainframe Sizes-8 channels, 18 channels, 28 channels
 - Full Metering
 - Timer on All models
 - Talkback to "2" studios
- Ultrahigh Quality Construction and design
 - Penny and Giles 3000 Series slide faders
 - VCA's
 - ITT Schadow switches
 - Gold connectors-IC's socketed-regulated power supply
- 3 Stereo Output Buses
- 2 Internal Mix-minus Buses for 'Telephone'
- Option Modules-D.A.'s, Mono Mixes, Remote Selectors, Etc.
- Comprehensive Logic system
 - Start and stop sources by isolated internal reed relays
 - Remote channel On and Off control with Tally lamps for turrets
 - Flashing OFF switches for cart machine status
 - Three muting buses for Control room and two studios
 - Timer reset selectable on each module
 - Monitor DIM function during cue and talkback

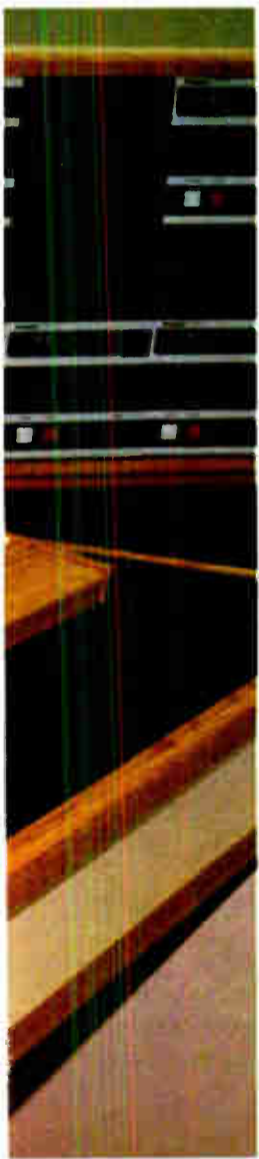

24-2248



arrakis
SYSTEMS, INC.

**NEW
NEW
NEW
NEW
NEW**

NEW NEW NEW

When You Consider Remote Possibilities...



PLXmicro Frequency Extender/Encoder

Perfect complement to a cellular phone, transforming the sound to broadcast quality. Provides connections for microphone, tape and headphone. Compact size. Battery-operated. Full duplex operation.



Multiline Frequency Extender

The most sophisticated and easy-to-use frequency extender available. This versatile 1, 2, or 3 line system automatically dials, levels and equalizes your line at the push of a button. Incorporates Comrex unmatched noise reduction.

Consider Comrex. We're the people who pioneered the frequency extender and have set the standard in broadcast quality telephone transmission for nearly 30 years.

Comrex covers every remote possibility—in radio, television and teleconferencing. Comrex equipment is specified by networks and stations worldwide who understand the paybacks of Comrex dependability.

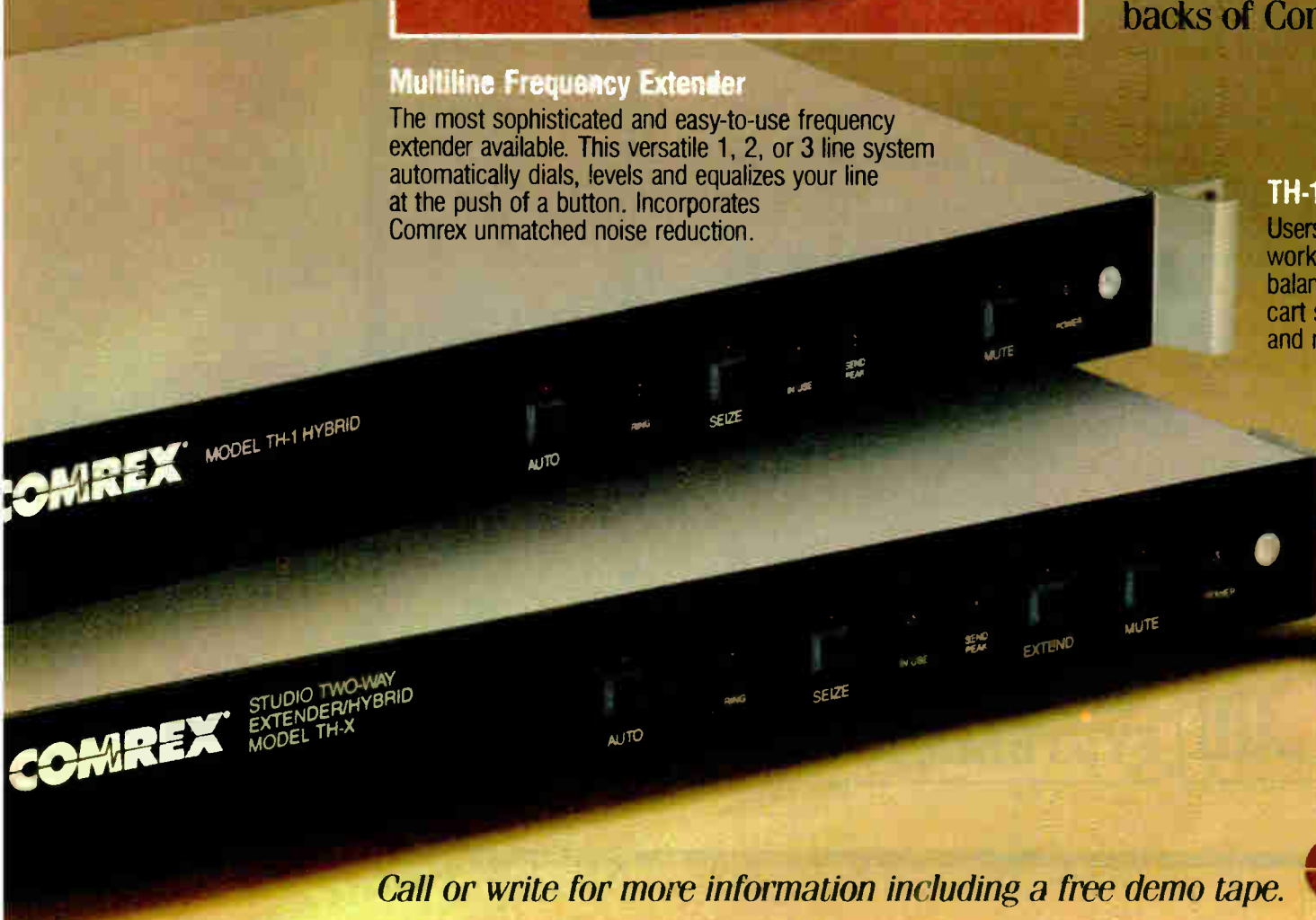

TH-1 Hybrid

Users say it's the "best hybrid we've ever worked with." Provides reliable broadband balance plus auto or manual answer, dual cart start, adjustable ring count, caller mute and more.

TH-X Extender Hybrid

Picks up where the TH-1 Hybrid leaves off. Combines all of the TH-1 features with transmit/receive frequency extenders and automatic caller leveling. Ideal for use with the PLXmicro and cellular phone for two-way, on-air remotes.

Call or write for more information including a free demo tape.

COMREX®

Comrex Corporation, 65 Nonset Path, Acton, MA 01720
1-800-237-1776 / (508) 263-1800 / FAX: (508) 635-0401

Circle 41 On Reader Service Card

World Radio History

Techniques for Stereo Miking

by Bruce Bartlett

Elkhart IN You may be called upon to do a remote broadcast or recording of an orchestra, string quartet or pipe organ. If your station is stereo, you'll need to understand stereo microphone techniques to produce such a broadcast.

These techniques capture the sound of a musical ensemble as a whole, using

LINE OUT

only two or three microphones, and are frequently used to record classical music ensembles and soloists.

During playback of a stereo recording, phantom images of the instruments are heard in various locations between the stereo speakers. These image locations—left to right, front to back—correspond to the instrument locations during the recording session.

Goals of stereo miking

In stereo miking a large musical ensemble, one objective is accurate localization. When this is achieved, instruments in the center of the ensemble are

In stereo miking . . . one objective is accurate localization.

accurately reproduced midway between the two playback speakers; instruments at the sides of the ensemble are reproduced from the left or right speaker, and so on.

Figure 1 shows three stereo localization effects. In (A), various instrument positions in an orchestra are shown: left, left-

center, center, right-center, right. In (B) the reproduced images of these instruments are accurately localized between the stereo pair of speakers. The stereo spread or stage width extends from speaker to speaker.

If the microphones are placed improperly, the effect is either the narrow stage width shown in (C) or the exaggerated separation shown in (D). Note that a large ensemble should spread from speaker to speaker, while a quartet can have a narrower spread.

To judge these stereo localization effects, it's important to position yourself

properly with respect to the monitor speakers. Sit as far from the speakers as they are spaced apart. The speakers will appear to be 60° apart, which is about the same angle an orchestra fills when viewed from the typical ideal seat in the audience (say, tenth row center).

Coincident-pair technique

With the coincident-pair (or X-Y) method, two directional microphones are mounted with their grilles touching and their diaphragms placed one above the other, angled apart to aim approximately toward the left and right sides of the ensemble as in Figure 2.

arriving off-axis.

That is, a directional mic produces a relatively high-level signal from the sound source it's aimed at and produces a relatively low-level signal for all other sound sources.

The coincident-pair method uses two directional mics symmetrically angled from the center line, as in Figure 2. Instruments in the center of the ensemble produce an identical signal from each microphone.

During playback, a phantom image of the center instruments is heard midway (continued on page 34)

Figure 1. Stereo localization effects

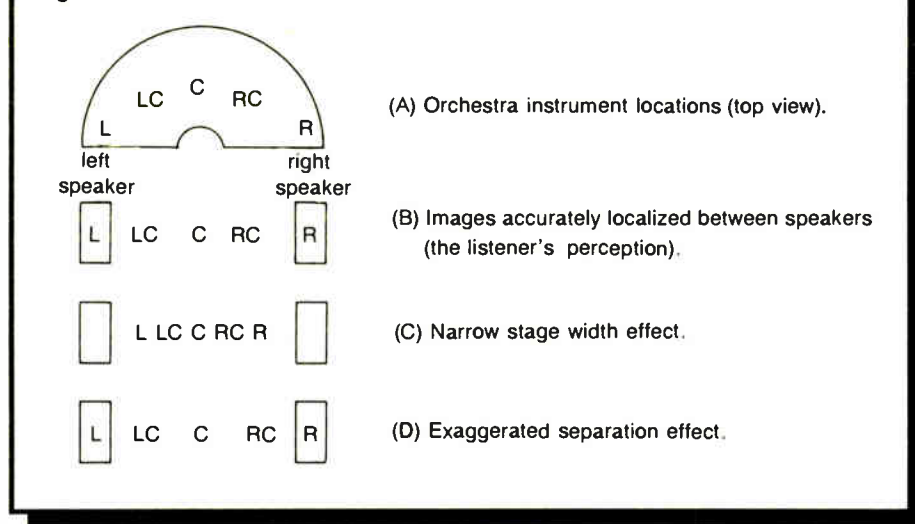

properly with respect to the monitor speakers. Sit as far from the speakers as they are spaced apart. The speakers will appear to be 60° apart, which is about the same angle an orchestra fills when viewed from the typical ideal seat in the audience (say, tenth row center).

Sit exactly between the speakers (equidistant from each); otherwise the images will shift toward the side on which you're sitting and will become less sharp.

There are three microphone tech-

As an example, two cardioid microphones can be mounted so that their grilles are touching and angled apart. Other directional patterns can be used, too. The greater the angle between microphones, and the tighter the polar pattern, the wider the stereo spread.

Let's examine how the coincident-pair technique produces images which can be localized. A directional microphone is most sensitive to sounds in front of the microphone (on-axis) and is progressively less sensitive to sounds

WHAT MAKES AUDIOPAK THE CART YOU CAN COUNT ON?



"DEPENDABILITY. Our final test involves dropping the cart from shoulder height. AA-4s clearly maintain azimuth better than anything else we've found. Consequently we've used them exclusively for years. Their performance has been exceptional."

Matt Rule, C.E.
 KZST, Santa Rosa, CA

If you're not this satisfied with your carts, call (800) 522-CART for more information.

CART AFTER CART...



P.O. Box 3100 • Winchester, VA 22601
 Tel (800) 522-CART or
 (703) 667-8125 • Fax (703) 667-6379

NRSC Conversion Special



ONLY \$2650.00

Why just convert when you can upgrade...for less

MIC-MAZE — STL or Telco Preprocessor
 Eliminates headroom problems

TRI-MAZE — Complete NRSC processing
 Including tunable cutoff frequency

ZH-1 — Main and Auxiliary transmitter
 peak control
 For precise modulation control on both your old and new transmitter

No other NRSC processing package offers so much performance and control for so little money.

hnat hinders inc

42 Elaine Street • R.R. 1 • Thompson, Connecticut 06277
 (203) 935-9066 • (203) 935-9242

The NEW, SX-87-MUX has the low price and digital performance you've waited for!



ONLY \$495.00

Why pay thousands more . . .

The SX-87-MUX combines the isolation afforded by its unique Bi-Directional amplifier with a high speed feed and return path multiplexing scheme to provide constant nulls approaching 40dB in actual usage.

- No elaborate auto nulling schemes
- No fancy echo canceling digital algorithms
- No wallet shrinking price tag

The only thing elaborate about the SX-87-MUX is its performance!

Before you mortgage your next hybrid, consider buying one of ours. The only real difference is the price!

NOTE: Direct replacement SX-87-MUX logic boards are now available for all existing SX-87's. Upgrade your's today. Only \$148.00 FOB.

hnat hinders inc

42 Elaine Street • R.R. 1 • Thompson, Connecticut 06277
 (203) 935-9066 • (203) 935-9242

Microphone Placement For Stereo Recording

(continued from page 33)

between the stereo pair of loudspeakers. That's because identical signals in each channel produce a centrally located image.

If an instrument is off-center to the right, it is more on-axis to the right-aiming mic than to the left-aiming mic. So the right mic will produce a higher level signal than the left mic. During playback of this recording, the right speaker will play at a higher level than the left speaker; this reproduces the image off-center to the right—where the instrument was during recording.

The coincident array codes the instrument positions into level differences between channels. During playback, the brain decodes these level differences back into corresponding image locations. A pan pot in a mixing console works on the same principle.

The importance of mic angling

If one channel is 15 to 20 dB louder than the other, the image shifts all the way to the louder speaker. So, if we want the right side of the orchestra to be reproduced at the right speaker, the right side of the orchestra must produce a signal level 20 dB higher from the right mic than from the left mic. This occurs when the mics are angled apart sufficiently. The correct angle depends on the polar pattern.

Instruments part-way off center produce interchannel level differences less than 20 dB, so they are reproduced part-way off center.

Listening tests have shown that coincident cardioid microphones tend to reproduce the musical ensemble with a narrow stereo spread. That is, the

reproduced ensemble does not spread all the way between speakers.

A coincident-pair method with excel-

Figure 2. Coincident pair technique

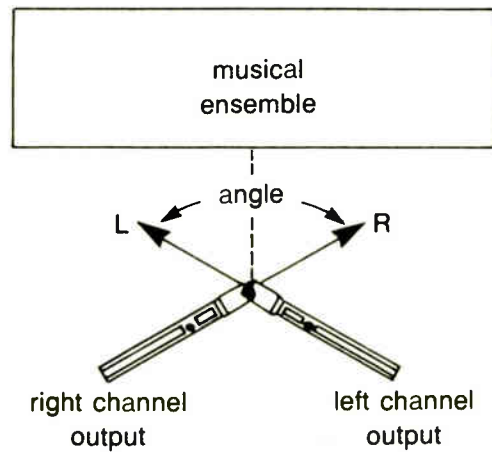
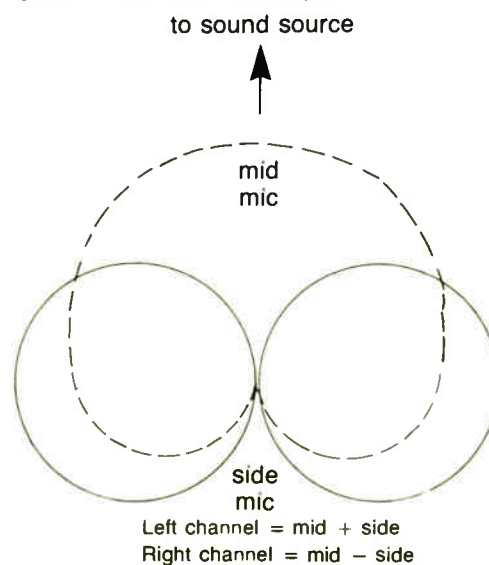

Figure 3. Mid-side technique



lent localization is the Blumlein array, which uses two bidirectional mics angled 90° apart and facing the left and right sides of the ensemble.

A special form of the coincident-pair technique is the Mid-Side (MS) recording method illustrated in Figure 3. A cardioid or omnidirectional microphone facing the middle of the orchestra is summed and differenced with a bidirectional microphone aiming to the sides.

This produces left- and right-channel signals. With this technique, the stereo spread can be remote-controlled by varying the ratio of the mid signal to the side signal. Such remote control is useful at live concerts, where you can't physically adjust the microphones during the concert. MS localization accuracy is excellent.

David Griesinger (of Lexicon) suggests

mono or stereo. This characteristic is very important for radio broadcasts because many people will be listening to your signal in mono.

Because of the coincident placement, there is no time or phase difference between channels to degrade the frequency response if both channels are combined to mono. If you expect your recordings to be heard in mono, consider coincident methods.

Hardware

A coincident pair of mics should be rigidly mounted with respect to each other so that they can be moved as a unit without disturbing their arrangement. A device for this purpose is called a stereo microphone adapter or stereo bar, which mounts two microphones on a single stand. Microphone angling and spacing

are adjustable.

To pick up the full spectrum of an orchestra, the microphones should have uniform response from 40 Hz to 20 kHz. Self-noise should be low (less than 20 dB A-weighted) to avoid hiss in the recording. A stereo pair of mics should be the same model number, and well matched in frequency response and sensitivity.

You may need to roll off frequencies below 80 Hz to eliminate rumble from trucks and air conditioning, unless you want to record organ or bass drum fundamentals.

Sound from an orchestra or band approaches each microphone from a broad range of angles. To reproduce all the instruments' timbres equally well, the microphone should have a broad, flat response at all angles of incidence within at least ± 90 degrees. Stated another way, the polar pattern should be uniform with frequency.

Next time: spaced-pair and near-coincident techniques.

■■■
Bruce Bartlett is a microphone project engineer and technical writer with Crown International. He can be reached at 219-294-8000.

76 kHz SCA

(continued from page 29)

the prime motivation for the project. However, creative uses can now be made of the SCA service, with the additional audio channel a technical reality in the network. KBSU's programming and marketing professionals have an opportunity to explore the new medium for the best application.

And an FM tradition may disappear which represents a loss to no one.

■■■
Tim McCartney is director of engineering at KBSU, Boise State University, Boise, Idaho. He is an SBE Senior AM/FM Broadcast Engineer, a former radio GM, and has a masters degree in human resources development.



Beaven Els, Chief Engineer, WFAA-TV Dallas

"Our ratings are powerful...and so are the demands of our equipment."

A television signal going to millions of homes can be a very complicated process. In Dallas, WFAA-TV has been THE dominant force for decades. This success is due, in large part, to the technical expertise BEHIND the camera.

As Beaven Els will attest, WFAA-TV is committed to investing in the finest equipment. From the most sensitive recording instruments to the electric clock in the lobby, WFAA-TV must have a reliable source of power. That's why Chief Engineer Els chose to have everything protected by the POWER SIFTOR® from Current Technology.

The effects of unfiltered power can wreak havoc in a television station. Digital equipment and computers can be destroyed by "dirty power", and the POWER SIFTOR typically eliminates these effects. And, Underwriter's Laboratories has made the picture even more clear by giving the POWER SIFTOR outstanding marks in the 1449 testing program.

Beaven Els is right. WFAA-TV's investment in programming and equipment are two reasons for the station's success. But without power protection, the station's "sign off" might occur earlier than scheduled.

Don't wait. Failure to act can result in permanent damage to your equipment! Our analysis of your power protection needs is free...and so is the call. 800 238 5000 ask for Peter Diamond, ext. 480



MP Series

CURRENT
Technology

1400 South Sherman • Richardson, TX 75081
(214) 238-5300

Power Siftor and The Power To Succeed are registered trademarks of Current Technology, Inc.

The Power to Succeed™

Circle 15 On Reader Service Card

RTNDA Brings Hope For Improved Gear

by Phillip O. Keirstead

Kansas City MO Radio news directors attending this year's Radio-Television News Directors' International Conference in Kansas City heard what they have been waiting for: better equipment may be on the way.

Sony Corporation representative Art Gonzales told three dozen radio news executives that Sony engineers in Japan are studying the feasibility of enhancing a consumer audio cassette recorder to meet broadcast journalists' needs.

An RTNDA radio equipment committee has been urging manufacturers to market a sturdy, reasonably-priced cassette recorder for use by radio reporters. News directors around the country told the committee they were not finding economical replacements for their trusty Sony 110s and 142s.

Some news directors have faulted both Marantz and Sony consumer machines for lack of quality control, professional connectors, adequate pause controls, wrap-insert capability and sturdiness under field conditions.

Wire capture is the buzzword among a crop of new radio system vendors.

Sony's lowest-priced professional machine, the D-5 Pro, sells for \$870, putting it out of range for many radio stations. Some radio stations use low-price Radio Shack recorders, which are referred to as "throw-aways" among newspeople.

Analyzed requirements

Gonzales reported that he analyzed a list of professional requirements compiled by committee chairman Chuck Wolf of KIKK, Houston. Gonzales has asked Sony's planning group to study the feasibility of modifying the consumer TCM-5000 for professional use.

The proposed modifications included adding an easy-to-read VU meter, strengthened function controls, a numerical counter, a stereo/mono switch, audible cueing, XLR-type mic connectors and a modular telephone socket.

Gonzales expects the planning group to study the proposal for seven to eight months more before showing a prototype machine. If Sony agrees to manufacture a lower-cost professional cassette recorder, Gonzalez estimated the price of an enhanced consumer machine would be \$400 to \$500.

Delegates were also shown Sony's TCD D-10 professional DAT recorder. News directors howled at the unit's \$2900 price tag, but were told prices will fall because Sony is beginning to market DAT recorders to consumers.

Other remedies

Session chair Glynn Walden, engineering manager for the Group W AM stations, responded to a discussion regarding portable CD recording by saying DAT machines are more rugged and are bet-

ter suited for recording while in motion.

Some stations are modifying Marantz PMD-201s by replacing the mini plug socket with an XLR connector. Others have added modular phone plugs for telco feeds. Other stations have attached an outboard black box to Sony 5000s to add XLR and wrap capabilities.

Delegates also heard from Tandy/Radio Shack representatives, who reported that Tandy is introducing a shirt-pocket sized version of the low-cost VSC-2000 cassette recorder used by radio news people. Radio Shack's Model 102 laptop computer also continues to be popular among broadcasters.

Tandy is bringing out a new series of laptops, the 1400 FD and 1400 HD. The HD has a hard disk. Both machines have internal 1200/2400 baud modems and cellular phone plugs.

Recordable CDs

Tandy also plans to manufacture portable THOR (Tandy High-Density Optical Recorder) read/write audio CDs. A Tandy representative said the AC model of THOR will sell for under \$600. No price has been announced for the portable model.

One computer expert who was asked to critique the Tandy read/write CD said it still lacks durability for extensive repeat use.

On another subject, Wolf told session delegates the switch-over of National Weather Service data services to Contel, a private vendor, is running behind schedule.

Wolf said Contel has had problems in its contract office, and in the midst of the switch-over, changed customer service telephone numbers. Wolf added that Contel is taking 90 days to connect subscribers, leaving some stations faced with the possibility of having no weather wire during the changeover period.

On the floor

The RTNDA exhibit floor continued to be relatively barren of radio news technology, with the notable exception of newsroom computer vendors, who were literally tripping over each other.

Wire capture is the buzzword among a crop of new radio system vendors. The sudden surge of low-end system offerings has mature vendors scratching their heads, since inexpensive wire-capture software has been marketed for several years by firms such as Comprompter, Media Computing and News Technology Corporation, all of whom were demonstrating their latest software.

Basys has responded to interest in radio systems by marketing a low-priced system called the Basys PC NewsDesk. Basys provides software for use on a station's IBM compatible PCs. The system provides wire handling, assignment desk, scripting, Rolodex, messaging and personal file functions.

Dynatech NewStar is caught with an expensive radio configuration designed for major market news/information powerhouses. NewStar president Sande Smith told *RW*, "We'll be in the low end in one year, and we'll be in in a big way."

(continued on page 49)

America's Full-Time Broadcast Supplier

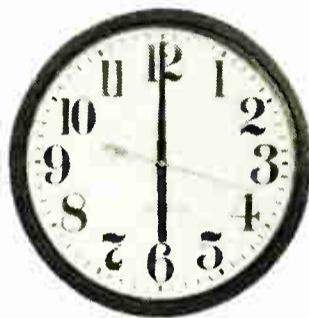

6:00-6:00
Pacific

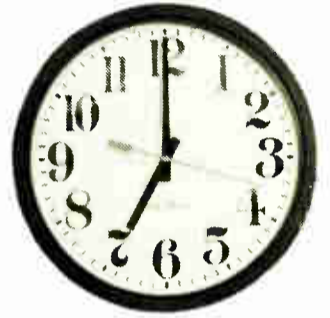

7:00-7:00
Mountain

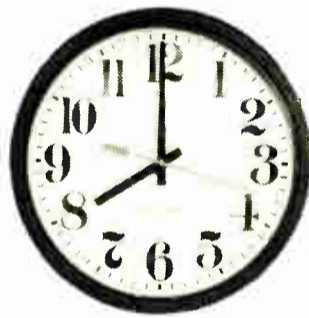

8:00-8:00
Central

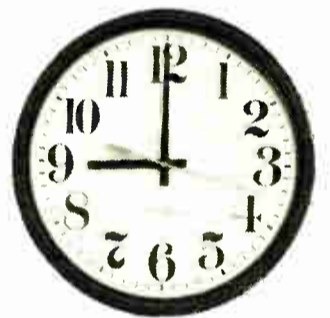

9:00-9:00
Eastern

When BSW was founded in 1973, our goal was to establish a single source supply house to serve the needs of America's broadcast professionals. Regional offices solved the problem of time zone but only served to delay delivery of equipment critical to a station's operation.

So we decided to work overtime every day of the week. 12 hours a day, there is a qualified sales engineer on duty who knows your business and your needs. And there's only one number you need to know — toll free across America. BSW's commitment to service is why we're America's full-time broadcast supplier.

BSW

BROADCAST SUPPLY WEST



1-800-426-8434

ORDERS • INFORMATION • SPECIFICATIONS
BSW • 7012 27th Street W • Tacoma, WA 98466 • FAX 206-565-8114

FCC Deluges Station With Stiff Penalties

by Harold Hallikainen

San Luis Obispo CA This month we'll review the 1988 inspection of an AM station that was struck by lightning, filed for bankruptcy and was inspected by the FCC. The violations resulted in a \$10,000 fine.

Some of the violations are probably due to the lightning strike. The FCC Rules do make allowances for things that go wrong (such as operating with reduced power, parameters at variance, etc.).

These rules outline specific procedures to take when you operate with reduced power, DA parameters at variance or with EBS equipment that has failed. Let's go through the violation notice, commenting on each violation.

No file, improper operation

The station was fined \$300 for not having a public inspection file, as required by 73.3526. This section lists everything that must be in the file (see the 1 February, 1989 issue of *RW*). This might be a good time to check our your file!

The station also was fined \$2000 for operating outside the terms of license (73.1745). The station was operating with a non-directional antenna when a directional antenna was required, operating 40% over authorized power and interfering with another station.

Finally, the station had previously been cited for operating with the wrong pattern. The Commission allows operation with a non-directional antenna because of damage to a directional antenna system *provided* the requirements of 73.1680 are followed. These requirements include notification of the FCC within 24 hours and a reduction in power to maintain required fields.

Remote control required

The station's remote control was apparently damaged by lightning. The normal fine for operating without remote control is \$300. However, the station had absolutely no control over the transmitter, no monitoring capability and had been cited for the same violation previously.

Additionally, it was causing nighttime interference to another station and no one at the station knew what mode or at what power the station was operating. The fine therefore was increased to \$2000.

As mentioned previously, the rules allow for various pieces of equipment to fail (such as EBS generators, antenna monitors, even directional antenna systems). Should your remote control fail, the rules give you two choices: either put an operator at the transmitter site, or cease operation.

It is fairly common practice to put old

equipment into standby service when it is replaced. When a station buys a new transmitter, exciter or STL, the old one is kept operational to allow continued operation should the new equipment fail (for example, because of a lightning strike).

You may want to also do this with your old remote control equipment. The old equipment may not be as fancy, but it should keep you on the air legally.

EBS, tower violations

The EBS generator was not connected and the EBS receiver did not work. The station had been cited previously for the same violation. The operator did not know how to operate the EBS equipment. These violations resulted in a \$2000 fine.

INSIGHT ON RULES

In addition, no EBS tests were logged, resulting in an additional \$300 fine. There was no EBS checklist as required by 73.908. This, however, did not result in a fine.

At the antenna site, the tower fence was open. Since this is considered a public safety matter, a \$1000 fine was imposed.

All the lights on two of the towers were out and the FAA had not been notified. This resulted in a \$2000 fine (73.56, 73.48, 73.1213). Additionally, the tower light failure was not logged, resulting in an additional \$300 fine. (73.49, 73.1820)

Other violations

The operator on duty at the station did not have an operator's license, resulting in a \$200 fine (73.1860).

The station was also cited but not fined for various other violations.

The station did not have a letter posted designating a chief operator (73.1230(b)). In addition, the chief operator license and all other operator licenses were not posted (73.1230(b)).

The station was operating at 3% of

licensed power. This was probably due to the lightning damage. The station would not have been cited if it had followed the procedures of 73.1560(d) regarding low power operation.

There were no equipment performance measurements as required by 73.1590(a)(6). Annual equipment performance measurements are required for AM stations (except as permitted under the new NRSC-2 rules).

There were no station logs as required by 73.1860. In its deregulation of broadcasting, the FCC eliminated the old program log requirement and combined the old operating and maintenance logs into the new "station log." Further, the Commission does not specify parameter logging intervals, except on non-approved DA systems. However, the station log is required.

The designated chief operator is to review the station log weekly to insure the station has been operating within compliance with the rules and the station license. Having transmitter parameters logged would make it easier for the DCO to insure the station has been operating within requirements.

Finally, the station did not have a common point ammeter, violating 73.58.

All of these violations could have been easily prevented if the designated chief operator was doing the job properly. From the documentation I have, I am not sure whether the station had a chief operator or not.

If you are the DCO of a station, I hope you find these monthly reminders useful. Look through your station. Are you meeting all the requirements we've mentioned this month? Are your station logs complete enough so that your review establishes that the station is operating properly?

Extension meters and controls

I just got a call on an interesting subject. A station has been cited for not having transmitter control in the control room when the transmitter (and its meters) are visible through a window (and about 30 feet away).

(continued on page 49)

CCA ELECTRONICS, INC.

25 Years of Reliable Broadcast Transmitters

For over 25 years, CCA Electronics, Inc. has provided reliability through simplicity. Specializing in simple circuitry and rugged construction, CCA manufactures dependable, longlife AM, FM, Shortwave and Longwave Transmitters.

CCA transmitters deliver durability and reliability to satisfied customers throughout the world. The high quality standards and design simplicity produces the best value of broadcast transmitters in the world.

FEATURES:

- Time Proven Long Life Design
- Rugged Construction with High Quality Components
- Zero bias Triode in DC Grounded Grid Circuit
- Conventional Plate Modulation
- Longest Documented Tube Life
- Designed for FCC, DOC and CCIR Requirements

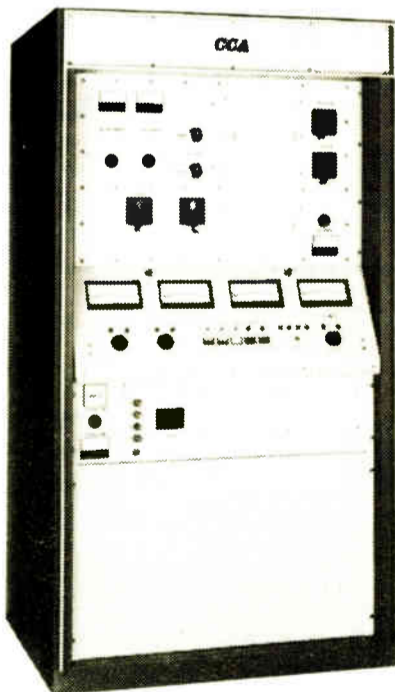

WE MAKE IT SIMPLE

CCA 360 Bohannon Road/P.O. Box 426, Fairburn, Georgia 30213
Phone: (404) 964-3530 Fax: (404) 964-2222

Circle 67 On Reader Service Card

OFF THE AIR? ANDREW AND CABLEWAVE CONNECTORS IN STOCK!

RF Specialties of Florida
PO Box 397
Niceville, FL 32478
Bill Turney
(904) 678-8943
FAX (904) 729-2744

RF Specialties of Texas
PO Box 8316
Amarillo, TX 79114
Don Jones/Tim Hawks
(806) 372-4518
FAX (806) 373-8036

RF Specialties of Washington, Inc.
19237 Aurora Avenue N.
Seattle, WA 98133
John Schneider /
James Kaplan
(206) 546-6546
FAX (206) 546-2633



Get back on the air fast! These RF Specialties offices now stock a full assortment of Andrew and Cablewave connectors for immediate delivery. For connectors or any other RF needs, call RF Specialties!



RF Specialties®
Group

- System Design •
- Competitive Pricing •

Circle 4 On Reader Service Card

A Wish List for Workstations

by Mel Lambert

Studio City CA It would hardly be a vivid exaggeration to state that, during the past year or so, the radio production industry has seen a virtual revolution in the way it is able to record, edit and otherwise produce audio.

With the advent of affordable, high-speed, full-function digital workstations, production engineering staff can begin to manipulate audio in a range of innovative ways.

DIGITAL DOMAIN

The introduction of digital audio workstations is also changing our perception of the types of tasks that can be handled within the digital domain.

Early processing

It wasn't so long ago that the expression "digital processing" referred to the types of signal manipulation that took place within dedicated delay, ambience and reverb units, followed more recently by digital equalizers and compressor-limiters.

One drawback, of course, was that few of these devices offered digital in/out. This was primarily because suitable interface standards had yet to be inno-

Audio signals no longer need to be re-digitized at each . . . port.

ated, but also because without ready access to digital consoles and other devices within the all-digital studio, an additional stage of D-to-A and A-to-D conversion was inevitable.

The introduction of affordable, modest-sized digital mixers, along with stereo and multitrack digital recorders, has changed all of that.

Standardized digital interfaces—AES3-1985, S/P DIF, SDIF-2 and others—allow component elements in the all-digital studio to communicate with each other. Audio signals no longer need to be re-digitized at each input and output port. Having been converted to digital data at the console input or a dedicated microphone preamp, a myriad of processing tasks can be performed entirely within the digital domain.

Blurred distinctions

The conventional distinction we currently make between production consoles, digital recorders and discrete digital signal processors—a delay/reverb unit, or a serially-controlled parametric EQ or compressor-limiter—are becoming blurred.

Most essential mixing, recording, editing and processing tasks, and others such as timecode synchronization and machine control, can now be handled more efficiently from a centrally located workstation. New microprocessor controllers and DSP chips pack more processing horsepower than ever before.

Practically all the tasks involved in the recording, editing and mixing of a radio production, jingle, PSA, etc., can be achieved within the digital confines of a workstation.

A new generation of companies is demonstrating a palpable understanding of the technology of digital processing and how to streamline the broadcast production studio of the not-too-distant future. If the resultant hardware is going to earn its keep in the broadcast facility of the 90s, manufacturers and system designers must display an intimate understanding of the essential role played by digital hardware.

Once the discrete tasks of recording, editing and processing become function-

ally centralized—simply because they can now be effected from a compact, PC-driven workstation—we can really begin to take advantage of the high-speed computational power of a dedicated minicomputer.

Dream sheet

During the past several months I've consulted with the developers of two, current-generation workstation designs. I've also been spending some time developing a "wish list" of vital features and functions.

My wish list of basic features for full-function workstations includes the following:

Real-time multichannel recording and

playback. Several workstation manufacturers make much of the fact that their designs can accommodate two-channel inputs, and/or possibly play back as many as four tracks at a time.

For a workstation to compete with the flexibility and capabilities offered by its analog equivalents, I am convinced that at least eight tracks of simultaneous input and output are extremely useful. Eight tracks would enable real-time mixing of hard disk digital audio "tracks" and/or would provide real-time throughput processing, such as digital compression, EQ, noise elimination and other functions.

Non-destructive editing and assembly. The
(continued on page 38)

When you hear the fidelity and accuracy of the AKG K 240DF Studio Monitor Headphones, you'll know why it's become a standard for recording engineers and professional musicians around the world. This latest version of our well known K 240 (now K 240M) has been created to meet a recently proposed IRT (Institute for Broadcast Technology) international standard. The K 240DF establishes a uniform sound quality free from environmental variables. As opposed to sound from loudspeaker monitors, that is colored by variations in control room design, the K 240DF is unchanging and reliable.

Each K 240DF is tested in a diffused sound field to arrive at a headphone design with a flat frequency response ($\pm 2\text{dB}$) and matched sensitivity. This professional headphone is close to perfection—without coloration or distortion. The self-adjusting headband supports the circumaural ear cups, each containing hand selected, large dynamic moving-coil transducers and acoustic filters. Minimum weight is maintained distributed for maximum comfort over long-time wear.

The AKG K 240DF Studio Monitor Headphones are available in two models. Just right for your studio.

AKG ACOUSTICS
77 Selleck Street
Stamford, CT 06902

© AKG 1985 © Akustische und Kino-Geräte GmbH, Austria

A Dream Sheet for Digital Workstations

(continued from page 37)

ability to shorten and otherwise manipulate versions of the original audio sound files, and to insert/assemble various segments together into a continuous program, is the primary reason for moving to digital editing from the time-honored razor blade and splicing block. Without this revolutionary feature, a workstation is little more than a fancy digital recorder.

Real-time audio mixing and signal processing. You've recorded the basic sound elements to hard disk (or erasable magneto-optical drives, once their access and data-transfer rates become fast enough) and they've been non-destructively edited to length. Now it's essential that the digital workstation allows the individual constituents of a radio program, commercial or PSA—for example, the narration, music tracks and sound effects—to be adjusted in level, mixed, equalized, level-compressed and otherwise processed.

The kinds of signal-processing tasks we can implement in a second- or third-generation workstation are truly staggering. Given sufficient computational power, they can provide dynamics control (compression, limiting, expansion/gating) and multiband parametric EQ, plus reverb, delay and ambience generation.

A dedicated work surface with readily familiar user controls. A truly user-friendly workstation must include a user control surface that features the kinds of level faders, switches and pushbuttons with which we are already familiar. "Glass consoles," or designs in which all system functions are intended to be controlled from a large monochrome or color monitor, are simply too cumbersome and non-intuitive to use.

In contrast, I am convinced that most radio production engineers would be far more comfortable with a combination of a high-resolution VDU, mouse or trackball for selecting edit points and setting up input/output designations, EQ and dynamics parameters. A control panel for level control of final mix balances and for making real-time changes in equalization and other parameters would also be welcome.

More wishes

Synchronization to SMPTE timecode. Our television brethren are extremely familiar with the myriad uses of timecode to edit video pictures, in addition to locking audio to picture. I would hazard that in this day and age of affordable DAT machines with timecode, it would behoove all radio engineers to develop a passing familiarity with 80-bit SMPTE

timecode.

In the future, time stamping a recording with timecode—even if the audio material is never intended to be locked to picture—will make more than a little sense. With a low-cost reader we can fast-forward search through the material looking for the relevant musical takes, interview sound bites and other material that needs transferring from the master reel.

Once the audio has been digitized within the innards of a workstation and stored to hard disk, the use of time-of-day timecode for selecting in/out edit

lists become vital features. After all, the workstation cannot be tied up for several hours with routine transfer of digital sound files to and from the hard disks or optical media.

A final wish would be the capability of a workstation to communicate with other subsystems within the production facility, including analog/digital audio recorders and synchronizers, using standard interface protocols. Flexible user control implies an ability to implement system-wide commands from a central location. In future radio production suites, the audio workstation should be

... engineers (should) develop a passing familiarity with 80-bit SMPTE timecode.

points and offsets make as much sense as anything. (And if, at some time in its life, the audio does need to be synchronized to picture—maybe for a simulcast, or some other audio-visual application—the data stream will already be indexed to time code.)

High-speed program backup and archival storage. Having built up a library of digitally-sampled dialog elements, effects tracks, music cues, station IDs and other material to hard drive, from time to time it becomes necessary to archive and/or purge the digital workstation, simply to free up disk space prior to the start of a new recording or editing project.

Here high-speed offloading of sound files and their associated edit-decision

capable of talking to any or all of the component elements.

The concept of digital processing has progressed far beyond relatively simple signal processors. Today's full-function on-air and production environments need to be provided with more processing power that ever before—an ideal, cost-effective role for the new generation of digital audio workstations now coming to market.

♦ ♦ ♦

Mel Lambert has been intimately involved with the production and broadcast industries on both sides of the Atlantic for the past dozen years. Now principal of Media&Marketing, a consulting service for the professional audio industry, he can be reached at 818-753-9510.

Loudness with Quality

(continued from page 25)

80% of the results come from 20% of the work. The question is, which 20%?

Get that major boost now by identifying the main bottleneck to having a loud sound. Is it ineffective processing, poor tape alignment, worn-out transmitter, narrow antenna or a faulty mod monitor?

In following columns, I'll share some

detailed secrets on how you can have a louder, more powerful sounding station even if you are a smaller station with a limited budget. The big guys don't always have to win.

♦ ♦ ♦

John Shepler is an engineering manager, broadcast consultant, writer and regular RW columnist. He can be reached at 815-654-0145.

CUTTING EDGE TECHNOLOGIES provide

SCA PROTECTION

5% More Modulation!

only with the

"DIVIDEND"

FM Composite Filter*

The DIVIDEND gives you:

- Full spectral protection to give you the most from your existing composite clipping/processing equipment
- A 5% increase in main channel modulation LEGALLY
- Full signal integrity for your SCA customers
- All of the above with no loss of stereo separation

Composite spectograph of a major market CHR at 110% legal modulation utilizing extreme composite clipping

The only composite filter available anywhere.

216-241-EDGE
FAX: 216-621-2801

2501 W. Third St.
Cleveland, OH 44113

Circle 1 On Reader Service Card

WorldRadioHistory

Circle 90 On Reader Service Card

Bi-directional RPU for \$250

with The Cellular Production Unit™

by The Davis Communications Group

By connecting our \$250.00 Cellular Production Unit™ to your cellular telephone, you get a fully bi-directional RPU system capable of interfacing with any audio gear you own, including frequency extenders. The CPU™ features a separate output for return



audio, and provides you with instant mobile remote capability from any cellular service location, without FCC licensing or RF problems.

- Sports Events
- Live News Coverage
- On-Site Promotions
- Boom Boxes
- Roving Interviews
- TV IFB/CUE

BROADCAST SERVICES CO.

CPU and Cellular Production Unit are trademarks of The Davis Communications Group.
Neal Davis, Four Oaks, NC, 919 934-6869 • Keith Arnett, Front Royal, VA, 703 635-1413
FAX 919 934-1537

KGON Readies New Tower

by Dee McVicker

Portland OR KGON-FM is erecting a 603' concrete and steel structure that will surely have future generations wondering how it moved such a mass onto Healy Heights.

Still in the infancy stage of its construction, with ground broken in July, the shared antenna will have at least a 75' diameter base and will accommodate three Class Cs and a community station. And despite what the tourist literature will say to future generations, the tower

will be using the latest in technology and materials to bring it to the hill.

The locals at Southwest Hills Residential League (SWRL) wouldn't have their Eiffel Tower any other way. In Portland, where RF ordinances tower even higher than the antennas themselves, the move to put the co-op tower up on Healy Heights was one that required engineers to roll up their sleeves and rub elbows with the community.

The beginning of a tower

It started, like a lot of tower constructions today, with Docket 80-90. In order to retain its Class C status, KGON needed to acquire a new antenna or restructure its existing antenna, which was 64' shy of the docket's height requirements.

This FCC docket, as well as a new city ordinance, gave the local homeowner's association the ideal opportunity to do some restructuring also. SWRL, which had formed a subcommittee specializing in radiation, wanted to consolidate radiation to one tower on Healy Heights, where there are currently six radio towers.

Consolidating all six radio antennas, the committee argued, would reduce the non-ionizing radiation levels in the community as well as interference to telephones, TVs, garage door openers and computers. Besides, they reasoned, one tower was only one eyesore.

The initial meeting between KGON and SWRL held promises that at least a

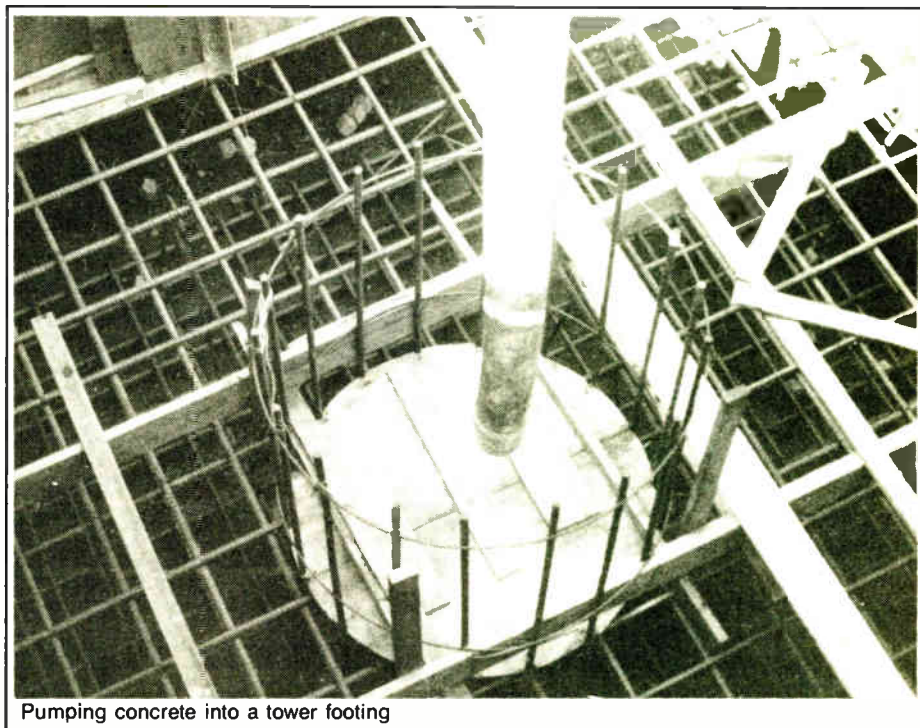

Pumping concrete into a tower footing

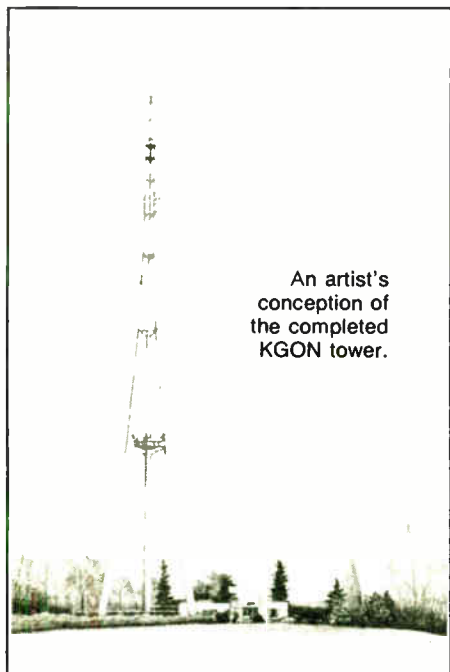

An artist's conception of the completed KGON tower.

two-station antenna compromise could be reached. Prior to the meeting, KGON had acquired a neighboring tower previously owned by Class C station KKSJ. The station had acquired the antenna at first to radiate its signal and later in hopes of radiating two signals.

Cost and approval worries

But, said KGON CE Larry Holtz, "we found that the cost of bringing that tower up to current building codes (for two sig-

nals) would be too expensive. Also, we knew that whatever we did to that tower, we'd need the approval of the association."

The approval of the association was being heavily weighted by a new RF ordinance not yet on the city's books. The new ordinance promised strict codes and KGON was confronted with the old ordinance as well. Said Holtz, "We thought, 'This is going to be a long term (continued on page 40)

Little Noisemaker.



This little gray box is about to have a big effect on the way you test your audio equipment.

No longer will you have to bother with individual tones to set proper audio levels. With Delta's SNG-1 Stereo Noise Generator you can make a variety of tests with *true* stereo noise, all at the flip of a switch.

You'll get a much more realistic view of what your equipment is doing. Whether you prefer white, pink, or USASI noise spectra, the SNG-1 provides it, in both continuous and pulsed output modes.

Say goodbye to hit or miss processor adjustments using varying program material. The award-winning SNG-1 spans the entire frequency range, so you'll cover the highs, the lows, and everything in between.

The external gate input permits an infinite variety of pulse shapes and durations so you can test your equipment to the absolute

fullest. For standalone convenience simply switch to the internal pulse mode.

With the SNG-1 you'll always get an accurate and repeatable standard to base your measurements on. And for only \$495, there's no bigger value.

To discover how the Little Noisemaker can help you in a big way, call or write today. And be sure to ask for your free copy of Delta's Noise Primer, "Employ Some Noise." Delta Electronics, Inc., 5730 General Washington Drive, P.O. Box 11268, Alexandria, VA 22312. Phone: (703) 354-3350, FAX: (703) 354-0216, Telex: 90-1963.

The Above Standard Industry Standard.

DELTA ELECTRONICS



©1989 Delta Electronics, Inc.

A Towering Neighbor Is Coming to Portland

(continued from page 39)

investment for us, so we better do whatever we needed to do to conform to the new ordinance as well as the existing ordinance."

KGON brought in structural engineers from firm Skilling, Ward, Magnusson and Barkshire. The firm proposed a 603' tower that would accommodate all six stations on the hill.

Radio's Eiffel Tower

"What we came up with is a self-supporting tower that has three legs that are five feet in diameter and 75' apart. (The tower) tapers somewhat like the Seattle Space Needle or the Eiffel Tower," Holtz said.

As an open frame structure with very few horizontal or diagonal members, the tower design, in theory, would also eliminate ice build-up.

For the association, this was indeed good news. However, they were still concerned with falling ice. So, said Holtz, "we hired a professor at the University of Washington" to test the design. Basing his report on 50 years of weather data and numerous tests, the professor satisfied the association's concern that if ice did fall from the tower, it would not fall on the homes nearby.

With the blessing of an association, an

FCC docket and two city ordinances, a conditional use permit was handed down to KGON for a six-station tower. It was now several specialized consultants and two and a half years later, and the tower still only existed on paper.

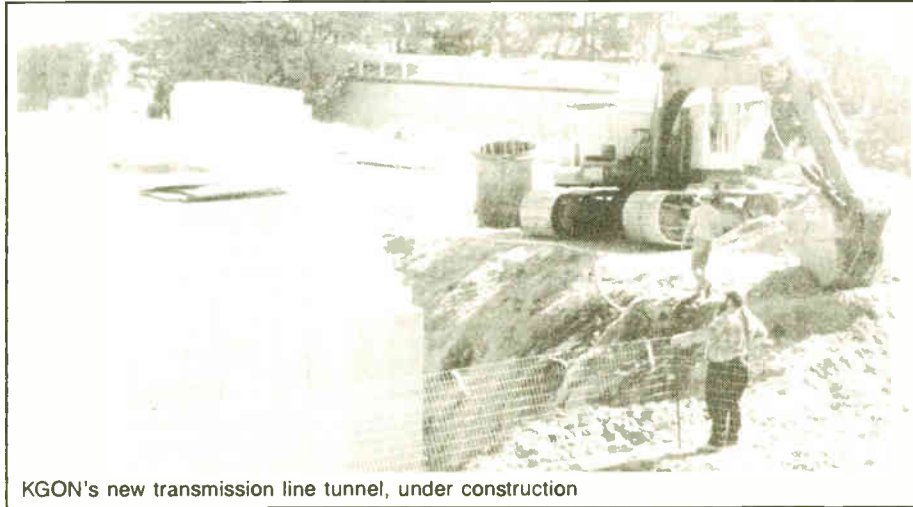

KGON's new transmission line tunnel, under construction

Even on paper, the tower looks impressive. Using high-strength concrete poured into a steel frame—a new construction method tested in Seattle and parts of California—the new tower will be a far cry from a community eyesore. In addition, it will afford three Class C stations, KPQD, KKSJ and KGON, and

community station KBOO to combine antenna operations.

But even more significant is the technology behind the tower. "The difference here compared to a lot of stations is the philosophy of how we're using the whole broadcast system," said Holtz.

A typical setup would have been to use two transmission lines; if one line went down, the other could carry the load until repair arrived. But, said Holtz, "we realized that it's impractical in Portland to operate on half of your antenna and repair the other half, because of (RF)

main and secondary transmission lines as well as all cabling. Should workers need to repair the system, a ladder within the center tube can route them past the secondary antennas without the need to power down the stations.

"Every 75 feet up the tower is a platform," said Holtz. "You can walk up the center tube, walk through the doorway and step out on a platform." The platforms, he said, will be used for mounting microwave and whip antennas.

Custom designed antenna

The broadcast antenna will be a custom designed Jampro JTC-3 spiral. With the antenna site located a mile away from the city of Portland, with plenty of hilly terrain in between, Holtz wanted to make sure that the signals would be able to penetrate the downtown area effectively.

The circularly polarized Jampro antenna, a design that originated in the TV market, offered KGON a consistent 50/50 ratio of horizontal and vertical power down to low angles—a plus for minimizing multipath and signal null problems in hilly terrains.

For the combiner, which will be Shively's four-balanced model 2520, the station also decided on an atypical setup. Said Holtz, "We're using a simple band-pass filter connected to the wideband input of the combiner to serve KBOO, instead of (putting the station's signal) in the loop with the other stations." Holtz claims this will yield a slightly better performance for KBOO.

Expected to be completed in December with on-air operation slated for early January 1990, the tower will have an underground tunnel running the full length from antenna building to tower. And, according to Holtz, the station plans to install an elevator late next year, after the dust has settled from construction.

No doubt, future tourists will appreciate the elevator.

■ ■ ■

Dee McVicker is a free-lance writer and regular contributor to *RW*. To inquire about her writing service, call 602-899-8916.

ALLIED
BROADCAST SYSTEMS
A HARRIS COMPANY

**PUT
YOUR
EGGS IN
ONE BASKET!?**

YES—ONE BASKET—THE ALLIED SYSTEMS BASKET!

Allied Broadcast Systems can do it all, from planning a single, low-cost studio to creating a major turnkey broadcasting complex (*no henhouses!*), complete with state-of-the-art studios, automation, RF, STL, transmitter and satellite down-link facilities. We do the worrying for you—let us evaluate your next project whether it be ground up or a simple update. You'll be glad when your trust and confidence in Allied pays off handsomely.

HARRIS/ALLIED ©1989

4500 CAMPUS DRIVE - SUITE 202
NEWPORT BEACH, CA 92660
714-752-6664

Circle B1 On Reader Service Card

World Radio History

Circle 32 On Reader Service Card

exposure to workers."

Instead, KGON elected to run a single, 9 3/16" diameter rigid transmission line. Said Holtz, "The idea is that if we should have a lightning hit, or something should go wrong in the combiner that would cause high standing waves to the transmission line, we'd be able to sustain those without damage."

Should the system fail, an emergency antenna system is designed into it so the four stations can maintain air time. Said Holtz, "At the 300' level of the tower we've given to each radio station his own emergency antenna and transmission line to the antenna." The ERI four-bay antennas are half-wave spaced to reduce radiation on the ground, a necessity to comply with the city code.

In addition, a tube 6' in diameter runs up the center of the tower, encasing the



Cellular Remote
**QUALITY BROADCAST
PROFIT CENTER**

The clear choice for quality. The Cellcast Remote Broadcast Studio is perfect for retail promotions, news, sports and special events. Cellcast combines the best features of a professional mixing console and a cellular telephone into one convenient package. Now remotes are fast and easy. If Cellcast sounds like a profit center to you, give us a call today!

CellcastTM

REMOTE BROADCAST STUDIO

CALL TOLL FREE 1-800-852-1333. Tri-Tech, Inc., 2415 East Skelly Drive, Tulsa, Oklahoma 74105

Interruptible Feedback Primer

Feed Cue Audio to Your Talent in the Field with This Monitoring Setup

by Andrew Ellis

San Francisco CA IFB, or interruptible feedback, is indispensable in television, but has been slower to catch on in radio.

Simply, IFB is a program monitor or other audio which is fed to talent or to a remote site. The feed can be interrupted by a push-to-talk microphone, which then substitutes microphone audio for the program feed.

With IFB, a single communications channel from studio to remote location can serve for both cue audio and communication. There are at least three audio sources that can be used to feed the IFB line in between communications.

Basic to elegant

Most basically, air monitor audio can be fed and used for most cueing. A step up from air audio would be a pre-delay program feed, which allows use of delay while still letting the remote staff hear sound in real time.

Perhaps most elegant of all, the IFB system can be fed mix-minus audio. This

(continued on page 43)

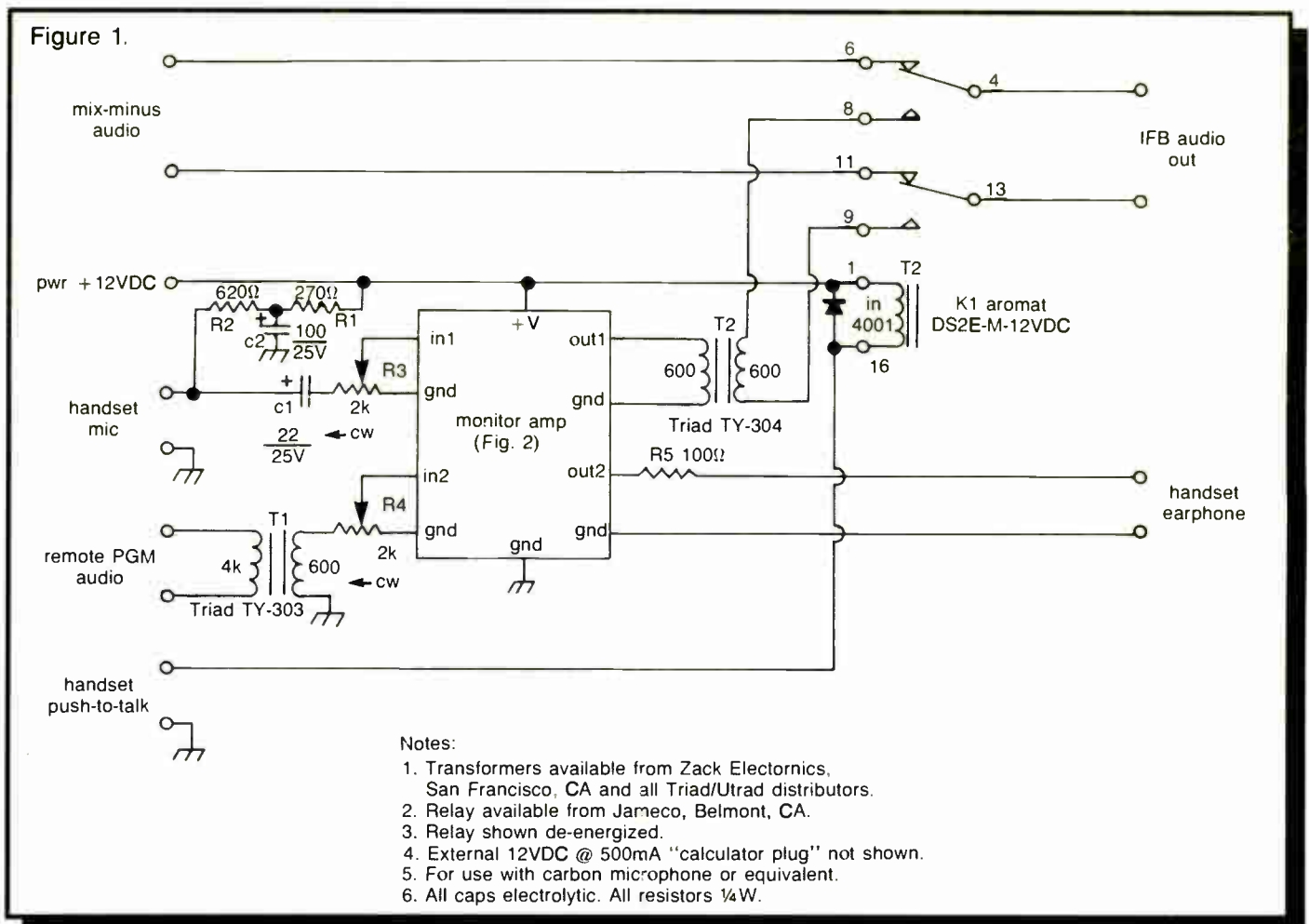

CRL SPOTLIGHT

Upgrading Your FM Processing?



The CRL FMIG audio processing system is the perfect answer for those of you with a small budget, but a large budget need for FM processing. With the FMIG you get the market's cleanest limiter the SMP-850, followed by the SG-800A digitally synthesized stereo generator. The SMP-850 features a powerful input compressor, followed by our exclusive variable transfer function pre-emphasis limiter. Image widening stereo sound field enhance circuitry is standard equipment. The SG-800A's digital pulse amplitude modulator produces a flawless baseband stereo signal. Find out what the FMIG can do for you. We have a two week trial program available. Call or write us for details.



CRL Systems
2522 West Geneva Drive
Tempe, Arizona 85282 U.S.A.
(800) 535-7648 (602) 438-0888
TELEX: 350464

MAKE THE MOST OF YOUR NIGHTS.

AM daytime broadcasters: Do you have a low power overnight authorization? Do you need an inexpensive backup for your main transmitter? Either way, a low power transmitter from LPB is your high performance solution.

- FCC Part 73 Type Approved
- Cost effective—low electric power consumption
- Compatible with all AM Stereo systems
- Compact design mounts on the wall
- Hundreds in service across the country
- Satisfaction guaranteed
- One year warranty
- Ten day delivery

Find out how easy it is to own, install and operate an LPB low power AM transmitter—and how low your overnight electric bill can be. Call John Tiedeck today at 215-644-1123.

LPB

28 Bacton Hill Road • Frazer, PA 19355
Tel (215) 644-1123 • Fax (215) 644-8651

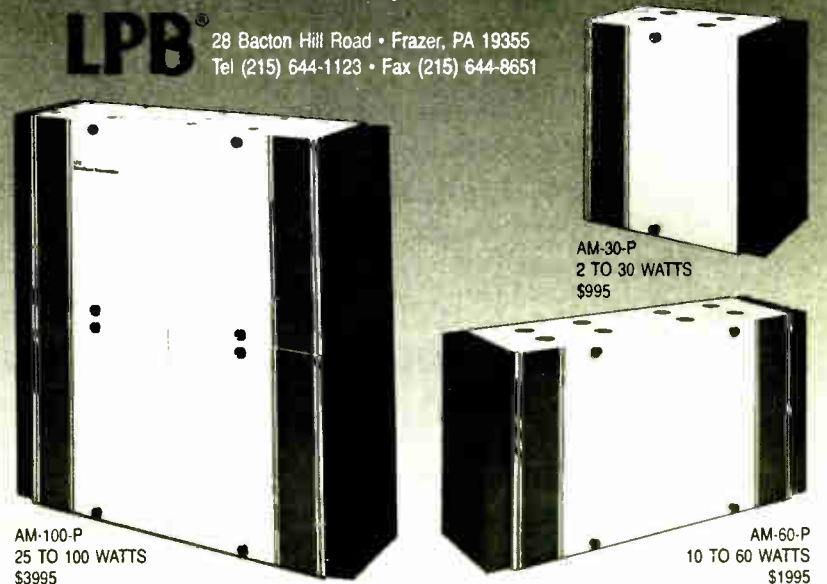

AM-100-P
25 TO 100 WATTS
\$3995

AM-30-P
2 TO 30 WATTS
\$995

AM-60-P
10 TO 60 WATTS
\$1995

MOMENT OF TRUTH

DYNAMAX[®]

COBALT TAPE CARTRIDGES BY FIDELIPAC[®]

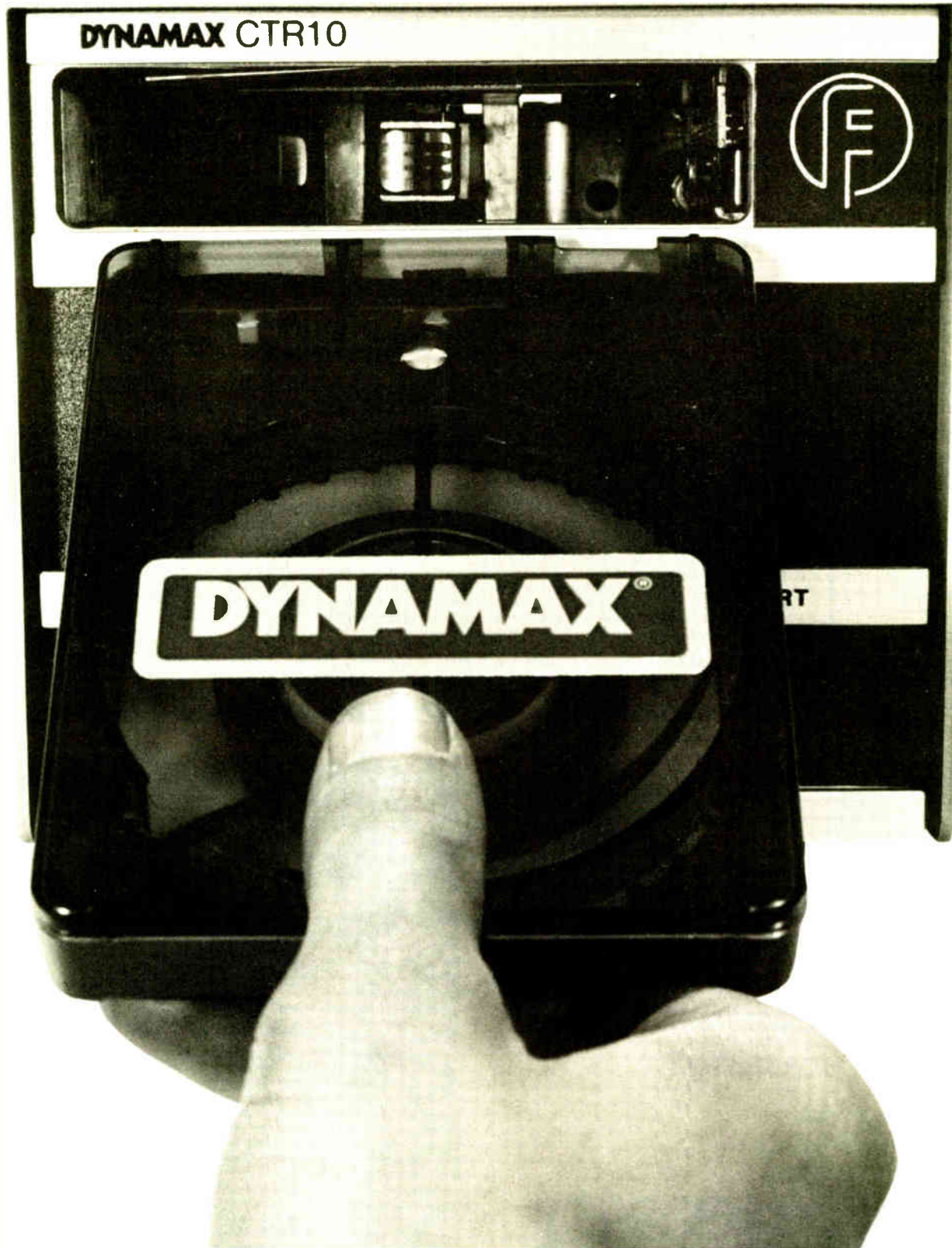

It's Time to Test the Metal...

Every cartridge you play means air time won or lost. Fidelipac's cobalt-formula Dynamax removes the doubt—you can count on Dynamax for a stand-out performance every time.

Want proof? Let Allied send you three FREE Fidelipac cobalt-formula Dynamax cartridges for your own evaluation. To get your free 70-second, 2.5-minute and 3.5-minute Dynamax carts, just send your request on your station's letterhead to: Allied Dynamax Offer, Dept. db, P.O. Box 1487, Richmond, IN 47375. Offer subject to change without notice.

Test Dynamax off the air. Learn why they're the best on the air.

ATLANTA, GA CHICAGO, IL DALLAS, TX
LOS ANGELES, CA RICHMOND, IN

800-622-0022

Circle 10 On Reader Service Card

ALLIED
BROADCAST EQUIPMENT
A HARRIS COMPANY

HARRIS/ALLIED ©1989

A Guide for the Use of IFB in Radio

(continued from page 41)

is a pre-delay mix of all the sound from the air console except the audio from the remote itself. The great advantage of mix-minus audio is that it prevents annoying echo on distant remotes by not feeding remote audio back to the remote.

Some broadcast consoles have mix-minus audio built in. In others, an unused buss can be assigned to the purpose by simply putting all the channels except the one used by the remote on it.

At KCBS, we have two main air consoles. Each has a mix-minus channel for remote broadcasts. A slave of the studio switcher automatically feeds the IFB from the mix-minus audio of whichever console is currently on the air.

The push-to-talk microphone handles the studio-to-remote portion of the conversation. The remote-to-studio audio can be handled in two ways.

First, one can simply assume that only the console operator will need to use the IFB. This allows him or her to simply listen to the remote audio in cue during

IFB is a concept rather than a particular implementation.

breaks. Since breaks are the only time the talent is available for off-air talk anyway, this is a simple and adequate method.

Alternatively, the IFB may need to be handled by a producer or call screener outside of the air studio.

Because cue audio may not be available in other rooms, KCBS used a different approach: The IFB handset gets audio from a bridging amplifier. The amplifier is normalled to our Comrex RTLX receiver, but can be patched to program lines or other remote site during breaks whether the console operator has the remote audio in cue or not.

Drawbacks, advantages

Obviously, IFB has potential drawbacks. Most seriously, it is possible for the producer to talk over a vital cue that the remote staff is trying to hear. The answer to this problem is vigilance by the producer to make sure there's still time

Figure 2.

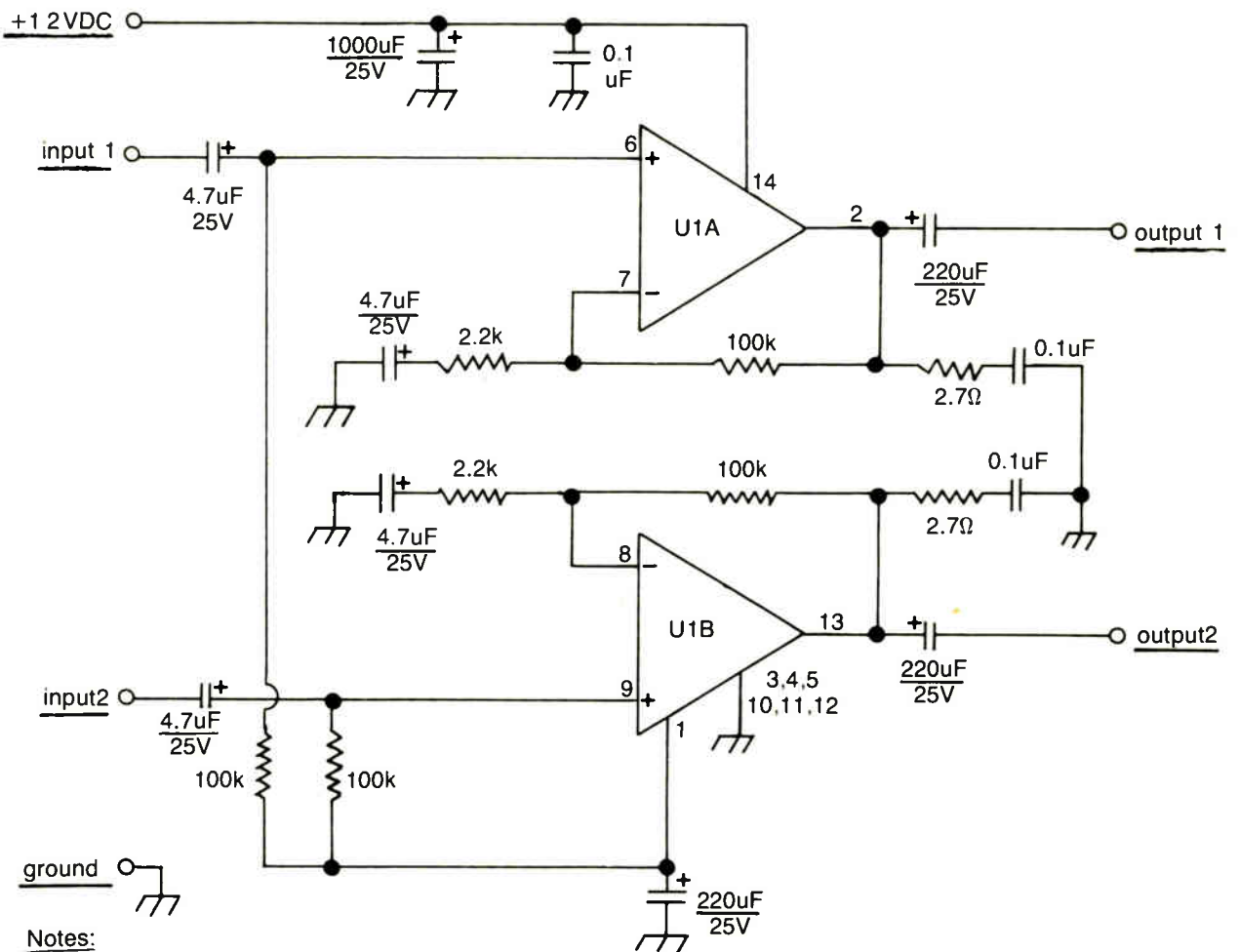

Notes:

1. LM1877 available from Jameco, Belmont, CA.
2. Polarized caps electrolytic, others disc.
3. All resistors 1/4W

U1-LM1877N-9

to talk before the end of the break.

Similarly, console operators must remember to keep the remote audio off the air console during breaks. Another possibility is to only partially mute the program audio while the studio microphone is in use. The push-to-talk circuit could be replaced with a noise gate to "duck" the program audio when the microphone is in use.

On a distant remote, IFB can be used for public address audio, too. In this mode, the remote technician mixes IFB and local audio to form a complete PA. In this way, hosts at the remote can take phone calls from the studio audience and the remote audience can hear both sides while still running in delay on the air.

Some of our remote talent take the chance to walk around and shake hands during breaks, and a quick "Back to you in 30 seconds" on the public address reminds them of the need to get back in place.

In TV, talent must be strong in the face of talk coming to them on earphones while they are talking on the air. This requires considerable skill, but if the talent is sufficiently sharp, IFB allows you to do this.

(continued on page 44)



ALLIED
EQUIPMENT EXCHANGE
A HARRIS COMPANY

BUY! SELL! TRADE!

These ol' boys wheel & deal!



JIM



CHUCK

Allied has been serving the needs of broadcasters for used radio equipment since the late 1960's. Veteran broadcasters are the "heart" of the equipment exchange business at Allied. Call on Jim or Chuck—their expertise is unparalleled. CALL TODAY!

The number to call is 317-962-1471.

We accept TRADE-INS,
SELL NEW & USED gear
& selectively BUY used
radio equipment. Let us
help you economically!!

P.O. BOX 1487
RICHMOND, IN 47375
317-962-1471

SOLID STATE POWER

Your choice for maximum loudness and efficiency

FULL MODULATION—NO OVERSHOOT

- 20 Hertz square wave modulation, 1.5 db more loudness
- 85 db signal to noise, transparent performance
- 4 watts to 5 kilowatts solid state power
- Transmitters, translators, boosters
- CTE offers high performance at reasonable prices

6034 Amberly Rd.
Rex Ga. 30273
(404) 389-1966
Canada (416) 692-3330
Worldwide FAX: (416) 692-4033

INTERNATIONAL BROADCAST SUPPORT SERVICES

We've made FM perform to the maximum the world over

Basic Principles of Interruptible Feedback

(continued from page 43)

A quick reminder that a break is needed can work wonders here. The mix-minus feed to the remote also allows the operator to sneak a theme or jingle audio to signal the remote staff to wrap up fast.

Yin and yang

If you need both halves of the system, a push-to-talk type of phone handset is reasonable. If you intend to rely on console cue audio for the remote-to-studio portion, a simple push-to-talk microphone of the type used for two-way radio will suffice.

Figure 1 shows the circuitry used for IFB at KCBS/KRQR. The headphone amplifier, the internal circuit of which is shown in Figure 2, is a dual two-watt monitor amplifier, but any small amplifier could be used.

The IFB uses a regular push-to-talk telephone handset of the type used on many newsroom telephones. These handsets are available from a number of two-way radio and telephone equipment vendors.

Typical routing arrangement

Normally, mix-minus audio from the air console is routed to the output of the IFB circuit through the normally-closed contacts of K1. The remote audio can be monitored on the handset through half of the amplifier coupled through bridg-

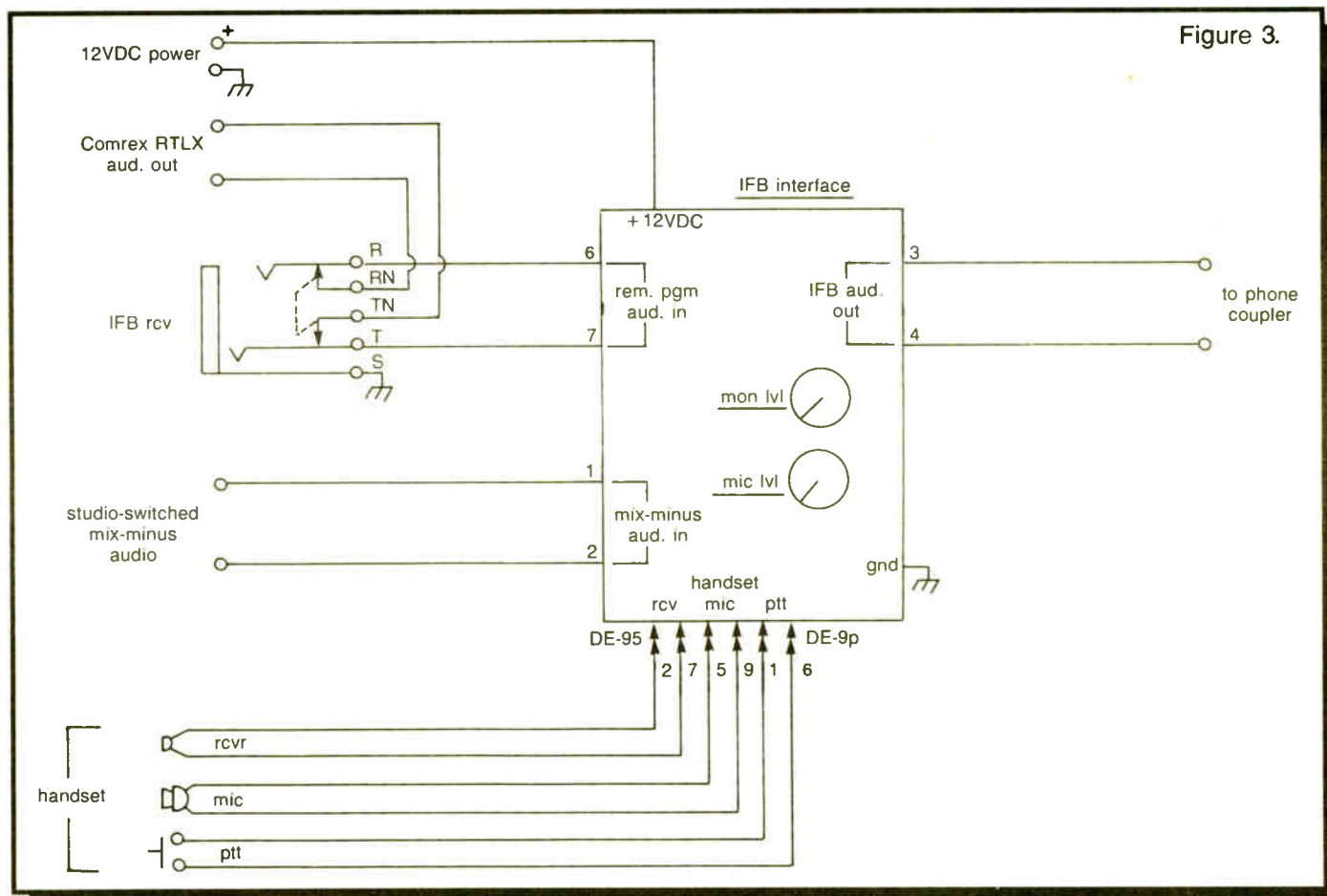

Figure 3.

ing transformer T1. R4 sets receive volume to a comfortable level while R5 limits maximum handset volume. Note

that a speaker could be driven also to allow the remote staff to get the producer's attention.

When the push-to-talk switch on the handset is closed, it pulls in K1, which substitutes microphone audio for mix-minus audio to the remote. R1-R2 and C1-C2 power the handset carbon microphone while keeping the DC out of the amplifier input.

R3, which is internally set, adjusts the transmit level to match mix-minus audio level. Since there are a number of possible uses for the audio, transformer T2 assures balance for any kind of transmission.

The circuit is built in a 3"x4"x5" enclosure of the type derisively called a "Buck Rogers Box." It's powered by a 12 VDC "calculator plug" transformer.

IFB is a concept rather than a particular implementation. The most common way to handle it is to provide an unlisted autoanswer coupler to feed the IFB audio back to the remote. But duplexing a transmitter onto a remote pickup receiver for IFB transmission is practical, too.

As the cost of dial-up phone lines continues to rise, the ability to save the cost of an added line or two at each remote makes IFB as economical as it is simple. The more remote broadcasts a station does, the more can be saved using IFB.

■ ■ ■

Andrew Ellis is CE of KCBS/KRQR in San Francisco. He can be reached at 415-765-4000.

Arrakis Authority

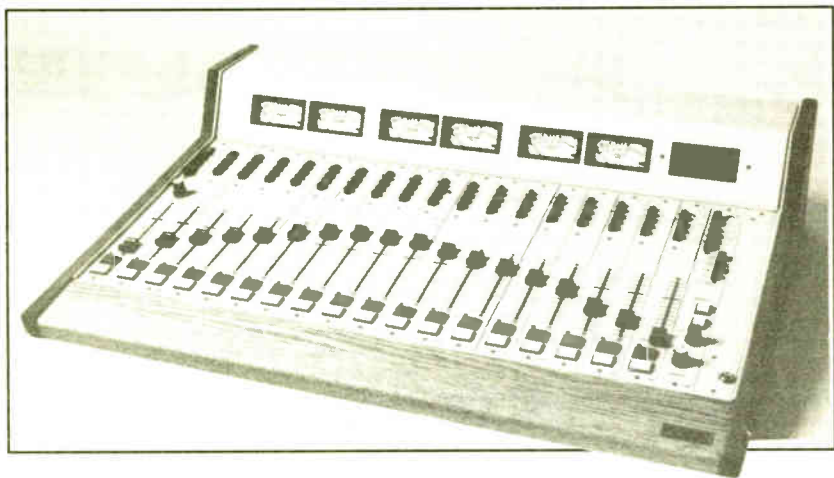

Northeast Broadcast Lab proudly presents the new Arrakis 12,000 Series. We'll help you choose the proper configuration to meet your present need and provide room for future expansion.

Get accurate advice, superior service and a poultry price from the Arrakis Authority. Call us today!



NORTHEAST BROADCAST LAB, INC.

MAIN OFFICE P.O. Box 1179 S. GLENS FALLS, NY 12803 Tel: 518-793-2181 Fax: 518-793-7423	MID-ATLANTIC P.O. Box 565 SOUTHAMPTON, PA 18966 Tel: 215-322-2227 Fax: 215-953-0523	NEW ENGLAND P.O. Box 406 AUBURN, NH 03032 Tel: 603-483-1002 Fax: 603-483-2352
---	--	--

Circle 49 On Reader Service Card

DATAWORLD MAPS

DO YOU KNOW YOUR MARKET?
YOUR COMPETITION DOES!

DATAWORLD MAPS CAN

- Depict your coverage!
- Market orient your sales people!
- Target your ethnic/demographic markets!
- Identify marginal signal areas!
- Plot any special requirements!

MAP OPTIONS

- SHADOWING (TERRAIN SHIELDING)
- POPULATION DENSITY
- CONTOUR COVERAGE
- SPECIALS

dataworld[®]
A Service of DW, Inc.

Fax (301) 656-5341
(301) 652-8822 (800) 368-5754

**Affordable STATI-
Lightning
Protection**

Charge dissipation with 1/8", type 304, stainless steel rods ground to needle sharpness. They won't bend from ice and severe weather. They provide a continuous low-resistance discharge path for the static electric charge on tall structures.

Let us design your system at
no cost or obligation!

Write For Free Brochure.

P.O. Box 2548, Farmington, N.M. 87499
(505)325-5336 Fax:(505)326-2337
Mastercard/Visa

Circle 84 On Reader Service Card



“Auditronics’ 224 helps Valerie Knight keep KZZP® No. 1 in Phoenix,”

says Robert Reymont,
Corporate Group Engineer
for Nationwide Communications, Inc.

“This wasn’t our first 200 series purchase, of course. That honor belongs to an early 218 serial 0045 which we bought for our Cleveland station WGAZ back in 1982. We’ve bought eight more Auditronics consoles since.”

“For KZZP, we purchased a 224 and have it set up to handle 30 to 40 hours a week of remotes. The mix-minus and the other needed features are all there. The DJ can answer the fifth caller, or the 25th, record the calls, then play them back on the air after editing.”

“A lot of our on-air talent come from other stations where they’ve had other consoles, and they find the Auditronics 224 a very easy console to operate. And there have been no failures or service problems. The only parts we’ve had to replace were conductive plastic faders made by another manufacturer.”

“Sound quality is very important to us, including dynamic range and noise level. So the 224’s low noise floor is an important factor. In fact, all our tape inputs and cart machines are dbx encoded. The result is that our prog line sounds identical to CD. Sure, we do a moderate amount of post processing (I call it “artful processing”), but with our Auditronics 224 and other similar quality equipment in the chain, our air product sounds demonstrably better than competition. The bottom line is that we’ve been the no. 1 hit music station in our market for over five years.”

Call toll-free 1-800-638-0977 today for more information about the Auditronics 200 series consoles Robert Reymont buys for Nationwide Communications, Inc.



Robert Reymont
Corporate Group Engineer
KZZP-FM
Mesa, Arizona
Nationwide Communications, Inc.



auditronics, inc.

3750 Old Getwell Road, Memphis, Tennessee 38118
901 362-1350 • FAX 901-365-8629

Life Support for Transmitters

by David Hebert

Pasco WA As we begin this installment, we find an engineer fumbling his way through the transmitter place, looking for the metric crescent wrench he needs to adjust the grid-leak catch pan for maximum effectiveness.

Last week he asked his boss, Mr. Sneedhorn, for a new metric crescent wrench so it could always be kept at the transmit-

ter place. It seems that some gremlins always like to hide this special tool from our friend so it's not always there when he needs it most. What's a fella to do?

How many of us have had to take, from time to time, that emergency run to an unfamiliar mountaintop, to find the only resources we have available to fight the problem are hanging at the bottoms of our arms? The

building is devoid of rags, tubes, instruction books or anything else that might even begin to make the task easier (or enjoyable).

Before Old Man Winter begins to breathe that cold, biting breath on the transmitter place, now is a good time to ensure a life support system for the transmitter.

Let's look at some items, which should be available at the

remote transmitter site, that can aid in normal and emergency maintenance periods.

The most important item on our list, of course, would be a current instruction manual for each piece of equipment at the site. Most manufacturers will usually provide two instruction manuals for each piece of equipment. It's always helpful to keep one copy at the remote site and another down at the studio.

Another item, running a close second, would be a maintenance schedule, in writing, of important meter readings, component replacements and general information.

Next on our list of essentials would be a tool kit, complete with a VOM and other necessary items one might need to diagnose and repair most problems. It goes without saying that we can really get elaborate with the types of tools kept in stock.

I won't argue with anyone who wants to keep two or three of each and every tool he may need at the transmitter. Even a good workbench can make one feel right at home during a hand-to-hand bout with a snarling transmitter. But we have to start somewhere, right?

CONTRACT ENGINEER

Moving right along, a small assortment of resistors, capacitors, wire, tubes (known to be good), hardware and transistors can be worth their weight in gold. Every installation is unique to itself as to what specific items may be required.

Because it is difficult to anticipate your every component need, perhaps a trip to the local parts supply house can inspire some inexpensive parts assortment kits that could one could use in a pinch to fabricate a more exact needed part.

Other items

At this point, we can look at some other items that could help during our time of need. Of course, we won't even discuss personal items like bathroom tissue, drinking water or maybe an extra coat.

We can, however, think of spray chemicals such as contact cleaner, lubricant, freeze mist and the like. A good selection of rags (even someone's clean underwear), a small ladder and even a drop light with some extra light bulbs will always be put to good use. Some new air filters should not escape our shopping list.

Sometimes even the best of us lose our keys. I usually keep a building key hidden somewhere near the building and a spare set of car/truck keys inside. These ideas can save our poor engineer friend a long walk on a cold winter night.

And while we're at it, how about that spare can of gasoline? It's a long journey to the service station from most transmitters I've known.

All these suggestions are cost effective. Since time is money, efficient use of time will result in less money lost during a critical time.

◆◆◆
Dave Hebert is president of Dave Hebert & Associates. He is an occasional contributor to RW and can be reached at 509-545-9672.

It takes plenty of guts to back our products this solidly.

At QEI, we back our products — and our customers. Our power tubes, for example, carry the best warranty in the industry: 15,000 hours or 2 years. And only QEI includes a FREE comprehensive spare parts kit with every FMQ transmitter, exciter and remote control. Experience shows that you may never use more than 2 or 3 of these "guts". But since we can't be certain *which* 2 or 3, our kits include ICs, transistors, lamps, diodes, fuses — everything you're *unlikely* to need.

24 HOUR SERVICE HOTLINE

Giving you the most complete spare parts kits in the industry is just the first step in a customer support program that lasts as long as your QEI transmitter. If you need expert advice on installing a spare whatever, call us any time at 609-728-2020, day or night. And if you ever need factory parts support, we can deliver — fast. We're just 1/2 hour from Philadelphia International Airport, not out in the middle of nowhere.

MAXIMUM EARNING POWER

You can count on it with every QEI transmitter, because we design them to stay on the air. And as a fully integrated company dedicated to RF and transmission products, we're able to build in quality and reliability — and still maintain our value advantage.

No wonder stations in both large and small markets have been using QEI products as long as we've been making them — since 1971. During that time we've put over 1300 exciters, more than 450 transmitters and over 1000 modulation monitors in service.

GET THE FACTS

When it comes to standing behind our products — and our stations — we're way ahead of the competition. That may make other manufacturers nervous, but it makes QEI customers very satisfied.



Call us at 800-334-9154, toll-free, for all the facts on the transmitters that deliver a solid return on your investment: the QEI "New Reliables."

QEI

Quality • Engineering • Innovation

QEI Corporation • One Airport Drive, P.O. Box D
Williamstown, New Jersey 08094
Toll-free 800-334-9154 • Fax 609-629-1751



DAT was invented for your home.

Rs DAT is for your studio.

Other DAT machines only take you halfway.

You need more in your studio than just a DAT machine. You need a DAT machine that can interface to your console and automation equipment. You need a machine with remote control and status information. And you need it to perform like a cart machine - - reliably and quickly.

Meet the RS-1000 from Radio Systems.

The RS-1000 is an integration of the Sony DTC-1000 and a special microprocessor-based controller from Radio Systems. Its features include:

- Full *broadcast* remote control (not a hard-wired remote, like most other machines).
- Rear-panel ports for automation and serial interface.
- Thirty cut, random access memory.
- EOM signals and relay closures.
- Automatic cue-to-cut.
- Cart machine style buttons and dubbing.
- Sampling rates for recording at 44.1 and 48 kHz.
- Balanced audio inputs and outputs.
- "Next" and "Last" functions for quick cut re-cue.
- Industrial-grade head life.
- 16-bit linear D/A conversion.
- Logging data.
- Total harmonic distortion < .0055%.
- Optional rack mount.

Imagine recordable digital audio in your automation system or as a live source in your air studio. And with DAT archiving, your entire music library can fit into a briefcase.

Call today for more information on radio's hottest DAT machine, the RS-1000 from Radio Systems.

RADIO SYSTEMS INC.

110 High Hill Road • P.O. Box 458 • Bridgeport, NJ 08014-0458
609/467-8000 • 800/523-2133 • FAX 609/467-3044

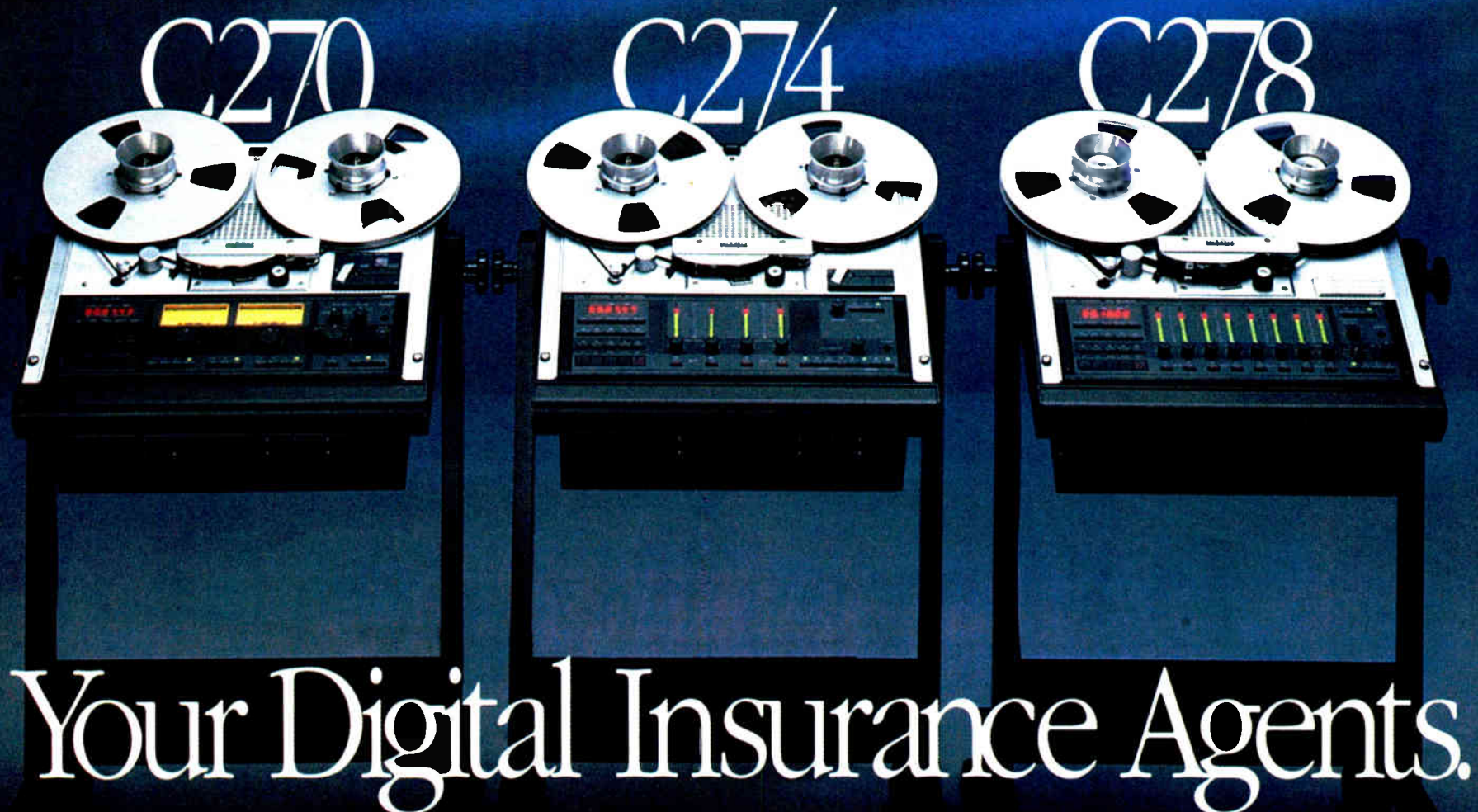

Your Digital Insurance Agents.

GET A GREAT DEAL ON A DYAXIS WORKSTATION WHEN YOU CHOOSE STUDER REVOX C270 SERIES RECORDERS.

DIGITAL INSURANCE A C270 Series reel-to-reel with a hard disk option? Yes, Studer has just acquired Dyaxis, the most price competitive and capable digital audio workstation available. Now when you buy a Revox C270 (or a Studer A807) Series reel-to-reel, we'll give you a discount certificate worth up to \$2,500 on your future Dyaxis purchase. That's your hard disk option!

THE C270 SERIES This exciting new line of recorders provides you with all the traditional Studer Revox benefits—mechanical precision, electronic sophistication, supreme sound quality and superior support—adding up to state-of-the-art analog recording technology. The C270 is available in 2, 4, and 8-track versions with or without remote/autolocator.

BEST BUY Compare the "street" price and performance of any C270 Series machine with the competition, and you'll find there *is* no competition. The die-cast deck plate and head block, the precision mechanics and a host of powerful features tell you any C270 Series machine will last as long as you need a reel-to-reel in this emerging era of digital workstations. And in the digital future, you'll need analog recorders that will sound good—for a long time. That's why your last reel-to-reel should be a Studer Revox.

TIME CODE...OR NOT The C270 2-track version offers optional center track time code for effortless synchronization to picture or sound. The C274 4-track and C278 8-track are both equally adaptable to production or post. The optional remote/autolocator stores 18 start/stop addresses and provides full transport and channel remote control to fit into any professional studio environment.

LOGGING TOO For station logging applications, special super low speed versions of the C274 and C278 are available with built-in time/date code generator and reader with search capabilities, providing up to 25 hours of continuous audio on one reel of tape.

STUDER DYAXIS With over 200 Dyaxis systems delivered worldwide, Studer has become *the* leading supplier of Digital Audio Hard Disk Systems, and the *only* major reel-to-reel supplier currently delivering such digital workstations. Buy either, and you choose a leader. Studer Revox.

Call your Studer Revox Professional Products Dealer—your Digital Insurance Agent—or Studer Revox direct to receive all the details. And remember, your purchase of any C270 insures that your future will be digital—with Dyaxis.



World Radio History

STUDER REVOX

Studer Revox America, Inc.
1425 Elm Hill Pike • Nashville, TN 37210 • (615) 254-5651
New York (212) 255-4462 • Los Angeles (818) 780-4234
Studer Revox Canada Ltd., Toronto (416) 423-2831

Circle 80 On Reader Service Card

RTNDA Focuses on New Gear

(continued from page 35)

Columbine is already marketing its system to radio stations with its most recent aural customers being KFI radio in Los Angeles and the Financial Business Network in New York and Los Angeles.

Siscom has done a system for National Public Radio and just signed a contract to install a statewide system for Minnesota Public Radio. Data Center Management is thinking about marketing a radio system.

The Associated Press stirred up excitement as the wire service introduced Version 2.0 of its AP NewsDesk wire management software. The system scans the AP's high speed wires and saves the data to disk. The news, sports and weather staff can scan the wire's files on a PC screen, printing out only needed items.

Keyboard commands for the AP NewsDesk are elementary. One key stroke can produce printouts of all desired stories.

AP expects to offer software to allow more than one terminal to take the wire, but an additional charge will be levied, since the wire service isn't trying to compete directly with full service newsroom computer vendors. Currently AP is sup-

plying NewsDesk software for \$15 a week, with free updates. AP Deputy Managing Editor Lee Perryman points out that savings in wire service printer paper nearly defray the added weekly cost.

More wire capture

UPI introduced its wire capture software, called News Manager 2000. It is new, not a reincarnation of the service's

earlier unsuccessful news computer product. This version was compiled with the skillful assistance of Peter Kolstad, of News Technology Corporation.

NewsVision is a product of Wynford Technologies, a Canadian firm with 13 installations to its credit. The system shown at the RTNDA runs on PCs and does wire capture, scripting and editing on a split screen.

Rick Boblenz and Avery Kronstadt

returned with their PC Newswire Manager software, which has been modified after experience gained from Philadelphia, PA and Trenton, NJ installations. The system supports multiple terminals.

Many observers felt the RTNDA exhibits, which are traditionally short on radio products, were further diluted by the competing NAB Radio '89 convention in New Orleans, held simultaneously.

Phillip Keirstead writes a monthly column on news technology for RW's sister publication, TV Technology, and occasionally allows his word processor to wander to his first love, radio.

Analyzing an AM Station's Fines

(continued from page 36)

It's been common practice to put a transmitter behind a window and not have any extension meters or controls, but apparently it has not been legal. Rule 78.1860(b) requires that "the operator be able to observe the required transmitter and monitor metering to determine deviations from normal indications."

Can you tell if you're between 90% and 105% power from 30 feet away? Is the phase of tower 6 within 3° of licensed? If you can read those meters from that far away, then you must have controls to

make necessary adjustments from the normal duty position. This might be just an on/off switch or may be more extensive.

If, however, you install extension meters that match the specifications of 73.1550, you do *not* need to add extension controls! I'm sure there are lots of stations that have the transmitter behind a window that may not be complying with this section. I've never heard of anyone being cited for violation of this until now.

I have seen several violation notices for stations where the remote control or transmitter is "down the hall" and not visible to the duty operator. Of course, if you use a dial-up remote control, you must be able to observe the remote control (the telephone) for deviations from normal indications.

FCC Rule 73.1860(b) was derived from the old 73.93(a) (AM) and 73.265(a) (FM), which required meters, monitors and controls to be readily accessible to the operator and "located sufficiently close to the normal operating location that deviations from normal indications of the required instruments can be observed from that location." So, it doesn't appear to be a new rule, just one that has not been enforced, 'til now.

I'll try to get more information on this matter. Thanks to Thomas Bowie for the call with that info. I'll look forward to hearing of your experiences.

Harold Hallikainen is president of Hallikainen & Friends, a broadcast equipment design, manufacture, sales and installation firm. He can be reached at 805-541-0200.

Birth of College Radio

(continued from page 27)

instrument flight plans because the controllers were not able to keep track of the off-airways flights for proper safety. It was, however, very useful for long distance navigation when there were no other hindrances to safety. All the pilot needed for this mode of navigation was three stations, the transmitting frequency of each station and the cities where the stations were located.

The publication TO #08-15-2 supplied the listings of the more powerful stations. Listings were cross indexed by state, city and frequency. The locals—1240, 1340,

1450 and 1490—had no listings.

Radio compass navigation took some rather rapid knob twirling to get the bearings quickly enough to obtain a decent plot. Still, it shows that radio was good for more than just entertainment while on some of those seemingly endless training missions.

George Riggins has experience in radio and electronics dating back to the 1930s. He is also a licensed ham operator and has had his own broadcast sales and service company, Riggins Electronic Sales, for over 20 years. He can be reached at 213-598-7007.



\$299

Clean up your act!

M100 Ultimike Microphone Amplifier

Eliminate dimmer noise, RF pickup, hum and rolloffs due to long mike cable runs by mounting this small, rugged, full featured preamp right at the source.

Features: • switchable gain • low cut filter • 48 volt phantom power • phase reverse switch • output limiter • DC remote gain trimmer.

The unusually quiet, servo controlled, instrumentation amplifier input has excellent hum and RF rejection and accepts up to +20dBu. A unique output driver provides distortion free transformer isolation, absolutely necessary for driving long lines.

Self contained power supply, Dual rack mounting.

Free Detailed Brochure & Full Specifications Available

AUDIO TECHNOLOGIES, INC.
328 W. Maple Ave., Horsham, PA 19044
(215) 443-0330 • FAX (215) 443-0394



YOUR ATTENTION, PLEASE!

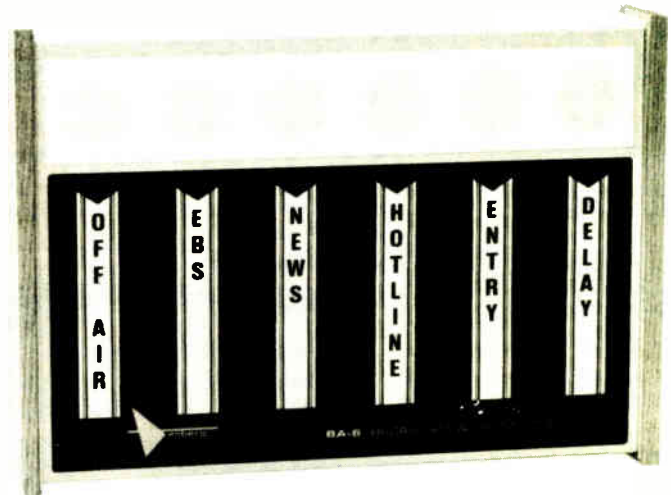

HARRIS/ALLIED © 1989

The BA-6 ALERT MONITOR now comes with new, ready-made labels. Listed below are the ALERT labels now included with each BA-6 and BA-6R. These titles should cover 99% of the common possibilities in the BROADCAST ALERT category.

User-applied vinyl lettering is still available and will be sent IMMEDIATELY upon request. In addition, duplicate labels or entire label sets are also available.

— Soon to come...BA-12 and BA-12R ALERT MONITORS —

- OFF AIR
- AM OFF
- EBS
- TTY
- AP UPI
- NEWS
- HOTLINE
- WRMLINE
- PHONE
- LINE 1
- LINE 2
- LINE 3
- LINE 4
- WEATHER
- ENTRY
- ENTRY B
- NETWORK
- CUE
- INTRCOM
- DELAY
- AUDIO
- XMTR
- POWER
- FIRE
- 2 WAY
- ANTENNA
- STL
- SCA
- REMOTE
- SWR HI
- STANDBY
- CODE

CALL
800-622-0022

ALLIED
BROADCAST EQUIPMENT
A HARRIS COMPANY

Radio World

Broadcast Equipment Exchange

"Broadcast Equipment Exchange" accepts no responsibility for the condition of the equipment listed or for the specifics of transactions made between buyers and sellers.

AMPLIFIERS

Want to Sell

Carver PM 1.5 450 W per chnl at 8 ohms, excel cond, 2 rack space, 24 pounds, \$650. B Fisher, KPOK, Box 477, Bowman ND 58623. 701-523-3883.

Radio Shack/Realistic MPA 80 high fidelity PA amp, 80 W RMS 4 mic inputs, 2 phono inputs, aux input. P Baillon, 612-222-5555.

QSC 1400 200 W per chnl at 8 ohms, 300 W per chnl at 4 ohms, mono bridging, octal accessory sockets, fan cooling, \$500. R Hoover Ross, The Auditory Perception Lab, 88 Sherman 2nd Fl, Brooklyn NY 11218. 718-965-2420.

Vital AA-1A (11) audio dist amps w/rack mount main frame, one input by 6 output. G Mundkowsky, 12918 Smalley, Grandview MO 64030. 816-966-0731.

Fender CBS Rhodes FR 7221 (2) solid state, main & slave for Rhodes cabinets, \$40/both. P Russell, Bowdoin College, AV Services Sills Hall, Brunswick ME 04011. 207-725-3066.

Bogen TCB 250 solid state 250 W PA amps (2), some repair, complete, \$225 ea or \$400/both; Altec 1590C 250 W PA amp, needs some repair, complete, \$300. J Sigmom, WBZK, POB 398, York SC 29745. 803-684-4241.

Fender Pro-Amp, could use a few new tubes, w/vibrato, brown tolex casing, \$400. B Ford, Spunk Prod, Box 1052, El Granada CA 94018. 415-726-4786.

Nakamichi 620 power amp, 125 w/ch. Audiophile's dream design. Like new, w/complete documentation, \$395. Klaus Heyne, 415-664-0163.

Ramko ESP-38 TT preamps (2), \$200 ea. C Green, Century 21 Programming, 800-937-2100.

Shure Vocalmaster 6 chnl 100 W, 4 out of 6 chnl work gd, \$150/BO. K Taylor, Image Support, 103 N Aspen, Sterling VA 22170. 301-864-4841.

Crown PSA-2 500 W stereo pwr amp, excel cond, \$750 pls shpg. W Laughlin, 753 Ruth, Hurst TX 76053. 817-282-9033.

Ramko DA mono in 3.5" cabinet, working cond, BO. P Hess, 134 Derwent, Pgh PA 15237. 412-366-1249.

Marantz 1 PM 200 stereo amp & pre amp, like new, \$150; Altec 1607A power amp & 5 chnl mixer w/meter, 200 W mono, \$200. J Parsons Sr, Parsons Electr, 10375 Cannas, N Huntington PA 15642. 412-663-9590.

Want to Buy

Marantz 7 preamp. J Parsons Sr, Parsons Electr, 10375 Cannas, N Huntington PA 15642. 412-663-9590.

ANTENNAS & TOWERS

Want to Sell

RCA 4 bay wide-icers tuned to 92.1 MHz, \$300; Jampro 3 bay high pwr tuned to 92.1, \$400; 322' of 1-5/8" jacketed Andrew cable, \$8/ft. J Thomas, WLEW, Bad Axe MI. 517-269-9931.

Andrews HJ7-50A 1-5/8" air 300' & 400', gd cond, 12 yrs old, \$900. C Benner, WUJL, 440 Domino Ln, Philadelphia PA 19128. 215-483-8900.

---FOR SALE---

Blaw-Knox 440' SS tower, \$125,000 installed; Harris 101.7 super high pwr FM antenna, like new & 500' 3-1/8" rigid RCA line, antenna & line \$18,000 installed; 2000' assorted 7/8" transmission line & 1000' 1-1/2" transmission line, assorted UHF/VHF 2-way antennas, \$150 ea.

Nationwide Tower Inc.
904-932-3004

Gates CS-1357 3 tower 2 pattern Gates AM directional phasor w/3-ATU houses & coax, \$3000. T Fernandez, WKXY, 2500 10th, Sarasota FL 34237. 813-366-4422.

Jampro JSCP-3 (3) elements tuned to 107.3 MHz, recently removed from service, \$1000 ea or \$2500/all. R Shroyer, KMWX, POB 1460, Yakima WA 98907. 509-248-1460.

Cablewave Heliax, 3" cable, 300' in various lengths, some new, some old w/6 connectors, \$3000. B Magrill, WYKS, 4908 NW 34th, Gainesville FL 32634. 904-375-2200.

Scala HDCA 10, FM, new & used, assorted freq, esp educ band, 75 ohm UHF & N termination, negotiable. R Archut, WKDN, 2906 Mt Ephraim, Camden NJ 08104. 609-854-5300.

New 3-1/8" - 1-5/8" flanged EIA reducers, bullets & elbows, many new BNC, UHF & N plugs & between series adapters, BO. B Royster, KQM, 1019 Cordova, San Diego CA 92107. 619-223-3413.

Andrew type 35381 tunable N jack connectors (4) for JH7-50A, 1-5/8" line, identical to Andrew type 87NT, w/tuning screws to adjust for minimum VSWR, new in box, \$200 ea/BO. C Osgood, WMMW, POB 2008, Conway NH 03818. 603-447-5988.

ICE KRACKERS, INC.

Inexpensive permanent protection of guy wire anchor hardware from guy wire ice slides. Average cost \$400 for 400-foot tower. ICE KRACKERS sized by guy wire diameter. All sizes available.

273 Circle Drive, Springfield, IL 62703

(800) 747-8921 (217) 786-6516 WSSU-FM

Ask for Jim Newbanks

Flanged heliax, 15-50' sections, 3-1/8 & 7/8", also some unflanged, (15) 3-1/8" elbows flanged, (2) 3-1/8-6" reducers, 6" Bird Thru-line section 50 ohms. J Kramden, WBRL, 3342 Perry, Marsellus NY 13215. 315-673-9049.

Rohn SSV Series, 160' self support tower, on ground, gd cond, not painted, new J rods, \$4000; Cablewave LFC-158-50J transmission line, 200' of 1-5/8", foam, never used, \$1650. A Wantuck, WAXY, 1975 E Sunrise, Ft Lauderdale FL 33304. 305-463-9299.

ERI FML2E 2-bay circular end fed antenna tuned for 100.9 MHz, \$2000; CBS FM Volumax peak leveler, mint cond, \$500. P Athanas, WRQC, Box 529, Richland Ctr WI 53581. 608-647-2111.

RCA 3 bay Class A, 106.3 antenna. T Rusk, KWTD, 704 Roberts, Lonoke AR 72086. 501-375-1440.

Rohn 65G 397' tower, 3 yrs old, guy wires, beacon, side lights, will sell standing, \$6000 or on ground, \$16000. M Blakemore, WCVP, Box 280, Murphy NC 28906. 704-837-2218.

Rohn 25 (6) 10' sections; tower bracket for Rohn 25; Cortana folded unipole-upper shirt. Adolph, 915-949-2112.

Hughey & Phillips TI2035 3.5 KVA tower isolation transformer, 115/230 VAC input 117-120 VAC output 3500 W w/instructions, \$1150. N Winter, KLAY, 10025 Lakewood, Tacoma WA 98499. 206-473-3462.

Andrew 1-5/8" gas pass Heliax flanges, (4) unused, \$75 ea/BO. D Carver, KZBK, 107 S Main, Brookfield MO 64628. 816-258-7458.

Scientific Atlanta 8005 earth station satellite antenna, 4.6 meter, disassembled, you pay shipping & labor to load, free. O Thein, Kirkwood Community College, 6301 Kirkwood Blvd SW, Cedar Rapids IA 52406. 319-398-5663.

Allied 42UCS/SR 65' self-supporting tower, 8 yrs old, excel cond, on ground, solid rod, \$5000/BO. O Thein, Kirkwood Community College, 6301 Kirkwood Blvd SW, Cedar Rapids IA 52406. 319-398-5663.

Andrew LDF 750A 1-5/8" foam xmsn line, approx 235' EIA flange on one end, type N reducer other end, BO. A Bowab, WDLT, 2402 Wolf Ridge, Mobile AL 36618. 205-344-3698.

ERI 8 bay Class C, 98.5 MHz, single bay, various RF connectors. T Rusk, KUAR, 2801 S University, Little Rock AR 72204. 501-569-8485.

Gates 1970 phasor & (4) ATU shelves set up for 1170 kHz, 5 kW DA-1, for parts list/price info, call K Buckelew, WOBN, 360 Clayton, Howell NJ 07731. 201-364-4400.

Various lengths of Heliax in various sizes, also various runs of cable, call for details. Adolph, 915-949-2112.

ERI FMHH G5-4 4-bay, high power horizontal only 4 bay antenna tuned to 94.5 MHz +/- 3 MHz. Available in Eugene, OR. Contact Chris Reid Murray, CE, KMG6. 503-484-9400.

Want to Buy

UHF TV bdc/translator antennas, Scala parapanels; any chnl, Scala SL-8; Bogner B Series or Bogner LPS 1, 2 & 4; UHF TV translator antennas on old chnl 70 thru 83 band; Scala SL-80 or parapanels; Bogner B4, B8, B16 or B24; Emcee DGA-10 corner reflectors. J Powley, 1536 Logan, Altoona PA 16602. 814-944-8571.

Broadcast tower, 300'-1000', 7/8 & 1-5/8" or larger feedline, 300' or greater. R Wichter, KNSX, 3418 Douglas, Florissant MO 63034. 314-921-2121.

UHF TV bdc/translator antennas, Scala parapanels, any chnl, Scala SL-8, chnl 19-23, 32-36, 60-84, Bogner B Series, chnl 20-30, 31-42, 55-69, or Bogner LPS 1, 2 & 4. J Powley, 1536 Logan, Altoona PA 16602. 814-944-8571.

Air heliax, 3-3/5", 350' or more on spool & in gd cond. K O'Malley, WNOR, 801 Boush, Norfolk VA 23510. 804-623-9667.

UHF TV translator antennas on old chnl 70 thru 63 band, Scala SL-8 or Parapanels, Bogner B4, B8, B16 or B24, Emcee DGA-10 corner reflectors. J Powley, 1536 Logan, Altoona PA 16602. 814-944-8571.

Rohn 65G, 10' tower sections, gd cond, on ground, want 18 sections. R Wallenburg, Electrocom, 2104 N Claiborne, New Orleans LA 70116. 504-947-4743.

Tower, 418' FM, 600' cable 1-5/8", 2 bay antenna tuned to 96.3, also beacon. LJ Maierhofer, WTGC, 101 Army, Lewisburg PA 17837. 717-523-3271.

Need 190' AM used guyed tower. G Vaile, KITA, 723 W 14th, Little Rock AR 72202. 501-375-1440.

CP antenna, 6-8 bay, tunable to 96.9 MHz, minimum 10 kW input rating; 500'-700' tower, must be cheap. D Carver, KZBK, 107 S Main, Brookfield MO 64628. 816-258-7458.

AUDIO PRODUCTION

Want to Sell

Shure M610 (2) feedback controller, 8 band EQ, BO. G Mundkowsky, 12918 Smalley, Grandview MO 64030. 816-966-0731.

Shure SE30 mixer/limiter, rack mtg, clean & perfect, \$150/firm; Shure M625/M625AM voice gates (4) in rack shelf, clean & working, \$75. E Davison, 135 N Illinois, Springfield IL 62702. 217-787-0800.

Audiolab TD-2 degausser, will handle 2" tape w/timer & fan, \$200 pls UPS; Altec 1591A compressor, mint, \$175. J Kreines, 5330 Kennedy, Millbrook AL 36054. 205-285-6179.

TTM-124 frame, 24 slots, 2/16 Telcom c4 cards, \$1500. R Rhodes, POB 1550, Nyny 10101. 212-245-5045.

Comrex TCB-1 telephone coupler; EV inline low-pass mic filters & mic pads, Luxo mic arm clamps & springs, 4" x 4" muffin fans & RCA DR-2000 Numitron tubes for ESE timers, BO; Dorough Electronics 40A (3) loudness meters in case; DAP 310 AM&FM limiter boards & pink noise board, BO. B Royster, KQM, 1019 Cordova, San Diego CA 92107. 619-223-3413.

Henry Mix-Minus, never used, \$185. T Drigger, 818 Quail Ct, Healdsburg CA 95448. 707-433-9370.

Howe 2100 Phase Chaser phase correction unit, excel cond w/manual, \$600/BO. C Osgood, WMMW, POB 2008, Conway NH 03818. 603-447-5988.

Orban XT2 6-band limiter accessory for use w/8100A-1, w/book, new cond, \$1700; Koss digital delay/reverb effects system, rack mt, vgc, \$300; Eventide FL201 instant flanger effects system, as new, w/book, \$400; Sansui QSE-5/QSD-1B 4 chnl encoder, decoder system, rack mt, configured for bdc & recdg std, w/Sansui match box & manuals, \$700; Dolby 334A/FM stereo audio processor w/Type 66FM peak limiter module, manual, \$800. E Stolz, KWOD, 1425 River Park, Sacramento CA 95815. 916-929-5000.

Audiolab TD-2 degausser, will handle 2" tape, w/timer & fan, \$150 pls UPS; Altec 1591A compressor, mint, \$175. J Kreines, DeMott/Kreines Films, 5330 Kennedy, Millbrook AL 36054. 205-285-6179.

SAE 180 4 chnl parametric EQ, excel cond, \$200. W Laughlin, 753 Ruth, Hurst TX 76053. 817-282-9033.

Revox B-77 remote tape drive control, full function w/25' cord, never used, \$50; Shure Level Lok audio level controller for mics, new, \$100; UREI 527-A 27 band 1/3 octave EQ w/security cover, \$450. B Spitzer, KKLS, Box 460, Rapid City SD 57701. 605-343-6161.

Want to Buy

Manuals & parts for Garron STE 100 stereo phase enhancer meter & schematic; Sta-Max composite clipper schematic; Harris MSP90 audio processor main frame, low pass filters, etc.; Harris Solid Statesman peak AM limiter; CBS 450 dynamic presence EQ manual. C Gill, POB 371, Indianapolis IN 46206. 317-923-2800.

BROADCASTERS

Strozier Electronics Inc. is now buying and selling new and used broadcast equipment. Call us TOLL FREE and compare prices and quality.
Call Charlie Strozier
1-800-888-5615

Realistic 12 band graphic EQ, stereo, & a stereo parametric EQ, \$100/both. R Coates, Lakes Recdng, 110 W 11th, Spencer IA 51301. 712-262-3113.

UREI 546 parametric EQ, \$500. B Musser, WMID, Ohio & Murray, Atlantic City NJ 08401. 609-344-5113.

dbx 224 simultaneous stereo encode/decode Type II NR unit, vgc, \$125. P Combs, Only Son Prod, 2316 Forest Home Ave, Dayton OH 45404. 513-236-2340.

\$499 MIC PREAMP w/ Jensen Transformers!

Model MP-2: Dual Channel, Bal Out, Pad, Phase Reverse, Metering, Headphone Amp. Call Now for our Catalog.
Gaines Audio 1237 E Main St. Roch, NY 14609 800-442-0780

dbx 142 NR units, w/manual, need I/O plugs, \$150 ea/BO. CRL SPP-800 stereo preparation processor, no manual, \$200. M Tosch, KIFM, 5125 Convoey Ste 304, San Diego CA 92111. 619-560-9800.

Mic Mix TW-1 time warp effects unit w/manual, as is, looks gd, \$75. D Bailey, 3422 Beech, Roullett TX 75088. 214-475-9796.

AKG stereo reverb BX 20 E w/remote, excel cond, amp updates, 2nd unit for spares, manual included, \$395/all. Klaus Heyne, 415-664-0163.

WANTED PULTEC EQ'S

We will pay \$1000.00 for almost any Pultec program EQ models EQP1/EQP1A/EQP1A3.

We will pay \$1500.00 for any Fairchild 660 and \$3000.00 for any Fairchild 670.

Also wanted: EQH2/EQH3/MEQ5/MAVEC/MB1/TTI & SONTEC EQ any S/ tube or ribbon mics and limiting amps.

CALL OR WRITE TO:
Dan Alexander Audio
2944 San Pablo Ave.
Berkeley, CA 94702
(415) 644-2363
FAX: 415-644-1848

UREI 527A EQ's (2), \$500/both; (2) 560 feedback suppressors w/rackmount, \$350/both. C Bucy, Cisco Snd, POB 16583, Lubbock TX 79490. 806-792-1662.

Luxo-LM 1 mic arm, beige, almost new w/able mount, \$30/BO. W Dougherty Jr, 314-998-2377 aft 6PM.

Beyer DT 109 headsets (2), vgc, \$100 ea. M Rice, WKBC, 2360 Hampton, St Louis MO 63139. 314-644-1380.

Various pieces of studio equip including Sound Craftsmen TG-2209-600 EQ; Ampex tube type mic mixer; Ampex 351 tube type R-R; Ampex tape transport system; mc swivel stands; BE cart rewriter; Tapecaster 700-RP stereo cart machine; Marti omni-directional antenna; Rust remote control system, call for details on all these items. Adolph, 915-949-2112.

Ron Radio Comm, Inc.
P.O. Box 201
Brightwaters, NY 11718

Inovonics Digital
Stereo Generator
\$1,095

AM NRSC
Add-On
Processor-\$ 520

1-800-666-3525
516-665-6482Fax

Pultec EQP-1, EQP-1A3, EQH-2 tube EQ's, will pay fair price/trade; API 550A, 560 EQ's, cash/trade; Apex/B&B CH-1 compressor/noise gates, cash/trade. J Pines, 217-367-3530.

Pultec EQs, tube compressors, etc, especially need Fairchild 660 or 670; also other vintage tube signal processing equip. J Kreines, 5330 Kennedy, Millbrook AL 36054. 205-285-6179.

Parametric or quasi parametric EQ in gd cond. R Coates, Lakes Recdng, 110 W 11th, Spencer IA 51301. 712-262-3113.

Older headphones & cards, call or write. J Taylor, WGCFA, Box 467, Quincy IL 62306. 217-223-7700.

Fairchild 670 stereo or mono model compressor; Pultec EQ-1A EQs, working or repairable cond. Mike or Tony, 615-824-9439, 9-5PM Central.

AUTOMATION EQUIP

Want to Sell

SMC RP1000/DS20 w4 SMC 350 RS B Carousels, all books, system kept in fine cond, w/spare cards, \$10K/negotiable. R Ferguson, KRRZ, 216 S Bdwy Box 10, Minot ND 58702.

Harris 9000 stereo automation system including (10) Otari ARS-1000 DS; (2) 24 tray 60 Cart II; ITC Delta triple deck; logging package; additional CRT console, \$25,000 complete. used only 6 mos. K Britton, WMMH, 17 Fern, Schenectady NY 12306. 518-356-1700.

Automatic electric telephone type relays & coils for Schaler 800 automation, BO. B Royster, KQM, 1019 Cordova, San Diego CA 92107. 619-223-3413.

Gates, various pieces of late 80s SP-10 automation gear for parts, inquire for complete list. D Kelley, KISZ, POB 740, Cortez CO 81321. 303-565-1212.

Automated Broadcast Controls w/(4) Otari ARS-1000DC reproducers, (2) 24 cart Carousels, 80 event sequence controller & audio controller, w/manuals, gd cond, \$10,000 pls shpg. B Herrera, KCRT, 100 Fisher, Trinidad CO 81082. 719-846-3355.

Sentry complete automation system including (5) Revox PR-99 stereo PB machines; Instacart; (2) IGM Carousels; (2) Audicord stereo cart machines; PC compatible computer w/software & interfaces, excel cond. B Ferguson, WMMJ, 400 H St NE, Washington DC 20002. 202-675-4800.

Sono-Mag MSP-1 sat automation controller, currently in use, perfect working cond, printer, manuals & spare parts kits included, \$3500. E Stokes, WCVR, POB 249, Randolph Ctr VT 05061. 802-728-4411.

REEL TO REEL DEAL

5% OFF

OUR NORMALLY LOW, LOW PRICES!

Through December 15, 1989

Call Now:
1-800-356-5844
608-271-1100

5618 Odana Road, Madison, WI 53719-1208

FULL COMPASS SYSTEMS





349.00
sugg. list

- *AUTO or manual reset
- *FLASHING indicators
- *30 labels included
- *Auto-isolated
- *Solid state relays
- *BA-6R remote available

BA-6 ALERT MONITOR

Your Ad Here
Will Be Read
By Over
21,000
Readers

Call Simone Leese
800-336-3045

MCI/SONY PARTS

New and Used... Your Best & Oldest Source in the U.S.A.

Custom mike panels, cue boxes, Sony and DIC DAT tape. DAT Recorders. Connectors, patchbays, cable for all Studio Construction needs. Full line Professional Audio equipment and Accessories.

In the Big Apple they Call Us First
audiotechniques
1619 Broadway, NYC, NY 10019
(212) 586-5989 FAX (212) 489-4936

AUTOMATION EQUIP . . . WTS

RCA/Control Design Corp 24 tray kartwheels (3) clock, programmer, needs work, BO. D Wolfe, KRIX, 901 E Pike Blvd, Weslaco TX 78596. 512-968-1548.

IGM automation system including (3) 48 tray Instacarts, mono, will sell separately, (3) Scully 280 stereo decks, (2) SCM stereo decks, (2) UMC time announce decks, Techtrid disc drive, Extel logger, Brain w/10K event keyboard, new CRT in carton, spare parts kit, (5) racks, \$6000 ea/Instacarts, \$17,500/system. K Stone. 512-345-9300.

BE 16X complete w/(4) Revox PR99s, time advance, delay record, live assist & much more, removed from service 2/89, excel cond, \$27,500. D Remy, KKLI, 2808 International, Colorado Springs CO 80910. 719-636-1000.

Insta-Cart 48 PBM, like new, all heads perfect, mono, \$5000 or trade w/extra control chassis. D Kohn KESM, 200 Radio La, Eldorado MO 64744.

Control Design CD-28, including racks, Carousels, R-R, time announce controller, gd working cond, spare parts, sell separately or as one. E Histed, WDNH, 350 Erie, Honesdale PA 18431. 717-253-1616.

Automated Broadcast Controls tone generator (2), \$150; Conex CS-25 Sensor, \$150; BE dual tone generator, \$50. C Green, Century 21 Programming. 800-937-2100.

Sparta 25-08C 25 Hz oscfilter for automation production, 2 chnls, \$150/BO. J McDonald. 303-669-3442.

Sono-Mag 252RS Carousel stereo, BO; IGM 78 tray go-cart stereo bi-directional, BO; (2) Gates 25 Hz tone controller, BO; Sparta 25SEN 25 Hz tone decoder, BO; Gates FA25 25 Hz stereo notch filter, BO. KDKB, POB 6184, Kingman AZ 86402. 602-753-KDKB.

IGM automation system, includes Basic A CPU, keyboard, CRT, hard drive, (3) Instacarts, (4) ITC reel decks, Sparta Carousel, IGM time announce, new IGM encoder w/Televideo terminal, all cards, interfaces, maint kit & manuals, \$9500. J Katz, KJUG, 717 N Mooney, Tulare CA 93274. 209-686-2866.

Revox PR-99 4 deck, original boxes; P-3A controller, BO. J Phillips, WZOM, 409-1/2 Clinton, Defiance OH 43512. 419-784-1059.

Want to Buy

ITC 770 PB, want up to (4). J David, KMPL, POB 907, Sikestol MO 63801. 314-471-1520.

Emcor SSP26A, need 3-5 that Sono-Mag shipped automation systems in, tops & end pieces not necessary but rack doors are. B Moore, KJEL, POB 1112, Lebanon MO 65536.

Entire set-up for Transar ACII & cart carousel. W Axell, KSAY, POB 2269, Ft Bragg CA 95437. 707-964-5729.

CAMERAS (VIDEO)

Want to Sell

Ikegami HL 79EAL w/Canon J13x9B lens w/2X extender, AC pwr supply, mounting plate, VTR cable, manual, extender board, & case, \$18,500; Sony BVU 110 recorder, w/time code card, \$2600. D Marin, 7 Minola, Lexington MA 02173. 617-861-1346.

RCA PK-301 vidicon camera, requires drive pulses, mono, w/maual, \$100; RCA PK-330 studio vidicon cameras, mono w/10-1 zoom lens, control units cable & manuals. B Humphrys, UMC 8500, Logan UT 84322. 801-750-3133.

JVC BY-110 3-tube camera w/case, (2) batteries, pwr supply & charger, (2) cables, 10X lens, like new, \$2300/BO; (4) JVC 1-tube cameras S-6U, \$400 ea/BO. T Quinn, Monte Vista St, 208 Cherry, Capitola CA 95010. 408-475-0423.

Ikegami HL-79D, 15:1 zoom, perfect, all access, \$9000; Sony Betacam, vgc, accessories, \$6000; one pass blank Betacam & U-matic tapes, \$4 ea. Ugly George, 212-677-2200, M-F, 9-5. Fax: 212-941-0956, 9AM-5PM.

Panasonic AK-100/AK-1040 5" viewfinder, like new (2), \$300. B Bridges, KCAM-TV, 827 Meridian, Nashville TN 37207. 615-226-1122.

Sony DXC-M3 3 tube, mic holder, cable, quick-release shoe, battery holder, 1.5 viewfinder, Fuji lens, molded case, low hrs, like new, \$3500. B Bridges, KCAM, 827 Meridian, Nashville TN 37207. 615-226-1122.

JVC BY-110 3 tube color camera, like new, pwr supply, case, (2) batteries, pwr supply & camera cable, shop manual, \$2200/BO. T Quinn, 208 Cherry, Capitola CA 95010. 408-475-0423.

Sharp XC-700 3 tube w/access, retubed, \$2000/BO; (4) JVC S-6U, 1 tube, \$600 ea or BO; JVC 2 KY-2700 3 tube w/14x1 zoom, \$1800/BO; Sony DXC 1640 1 tube, \$800/BO; Sony DXC 1610, T Quinn, Monte Vista Sts, 208 Cherry, Capitola CA 95010. 408-475-0423.

Ikegami 79D excel cond, just overhauled, \$6000; Sony Betacam portable studio cams, excel cond, \$6000 or \$10,000 for both. Ugly George, 212-677-2200, M-F, 9-5; Fax 212-941-0956, M-F, 9-5.

Want to Buy

RCA, Dumont, GE, pre-war & early post-war TV camera equipment, iconoscope, image detector, monitors, tripods, manuals for video museum. A Weiner, Britton Rd, Monticello ME 04760. 207-538-9538.

Dumont, RCA, GE old tube type TV cameras, image orthicon & iconoscope type. A Weiner, Britton, Monticello ME 04760. 207-538-9538.

CART MACHINES

Want to Sell

ATC PB-150 tube mdl, seems complete, gd for parts, etc, \$100/BO. J Sigmon, WBZK, POB 398, York SC 29745. 803-684-4241.

ITC Omega Series (2) playback desks, program cards need minor repair, otherwise excel cond, \$800 ea pls shpg. D Kelley, K1Z, POB 740, Cortez CO 81321. 303-565-1212.

BG Engineering BGE-1T new 10 minute digital up timer for retrofit into Spotmaster/ITC cart decks, BO; new semiconductors, IC's, lamps, motors, switches, rack ears, accessories for PDII, Delta, RP, SP, 3D, WP, Series 99 cart decks, BO. B Royster, KOM, 1019 Cordova, San Diego CA 92107. 619-223-3413.

Telex MC-PR III RP audio, excel cond, \$995. L Chatman, IVA, 424 Commerce Ln Ste 1, Berlin NJ 08009. 609-768-5006.

New STL NAB cartridge test tapes in mono, stereo & compatible formats, AA-2, AA-3 & Aristocart shells, BO; PR&E Tomcat R/P stereo & (2) stereo play cart decks w/spare parts kit, rack mount, also spare parts, switches, relays & heads for 270/280 series, BO. B Royster, KOM, 1019 Cordova, San Diego CA 92107. 619-223-3413.

Harris Criterion III compact 3 deck, clean cond, PB stereo, \$800. B McKittrick, B McKay Enter, 331 Mulberry, Catasahqua PA 18032. 215-264-5295.

BE 2000 R/P, 2 decks, one has new motor, manual, \$700/both; (3) Ampex 602 R-R decks for parts, BO. B Oostenburg, KCKY, POB 6, Coolidge AZ 85228. 602-963-9290.

UMC Beaucart RP stereo recond w/spare parts, manual, 3 tones, \$1125. B Carr, WRED, 1201 Fremont Plk, Toledo OH 43469. 419-837-9696.

ATC Criterion Series mono R/P, gd cond, \$300. B McKittrick, 331 Mulberry, Catasahqua PA 18032. 215-264-5295.

SMC 510 single cart player (2), \$150 ea/BO. J McDonald, 303-669-3442.

Telex MC-PRIII R/P, like new, \$950. L Chatman, IVA, 424 Commerce Ste 1, Berlin NJ 08009.

Rapid-Q ROM-2 R/P mono, fair cond, \$200 or trade. D Kohn, KESM, 200 Radio La, Eldorado Springs MO 64744.

Fidelipac Zenith & height gages for head alignment, never used, \$50. D Bailey, 3422 Beech, Rowlett TX 75088. 214-475-9796.

BE 5302B mono, triple decker, gd cond, \$1300. E Trevino, KBOR, Box 3407, Brownsville TX 78523. 512-541-6348.

3M/ITC Delta I stereo, gd cond, presently working. E Trevino, KBOR, Box 3407, Brownsville TX 78523. 512-541-6348.

SMC 792 mono, gd cond, \$900. E Trevino, KBOR, Box 3407, Brownsville TX 78523. 512-541-6348, Fax 512-542-4109.

3M/ITC Delta I stereo, gd cond. E Trevino, KBOR, Box 3407, Brownsville TX 78523. 512-541-6348.

BE cart tape winder, almost new, w/timer, both in original packing, \$425. G Cahill, Invisible Inc, POB 5786, Hudson FL 34674. 813-725-5003.

BE/Spotmaster TP-1A cart winder, without timer, \$100, will throw in 100 plus carts for \$150; (3) record amps, mono, for RCA RT-27/BA-27 series cart machines, \$40 ea. F Vobbe, Great Northern Bldg Co, POB 5031, Lima OH 45802. FidoNet 1:234/16.

Want to Buy

ITC 3D mono w/WRA record amp, triple deck. C Waltman, KNEW, 66 Jack London Sq, Oakland CA 94607. 415-836-0910.

Parts & manuals for RCA 7 Series; record amp for RCA 7 Series; parts & record amp for Harris Criterion ATC Series. C Gill, POB 371, Indianapolis IN 46206. 317-923-2800.

Rapid cue R/P mono or stereo, any model, schematics & operative units, must work, need several, may be interested in units for parts. N Williams, WTJZ, 553 Michigan, Hampton VA 23669. 804-723-1270.

Eraser splice finder. KDKB, POB 6184, Kingman AZ 86402. 602-753-KDKB.

Tapcater P & RP 700, any cond from junk to excel, call or write w/descriptions & lowest prices, complete or parts only. T Crockett, Hot Tracks, Box 10501, Blacksburg VA 24060. 703-953-0222.

Stereo record in gd working cond, used carts 40 sec, 70 sec, 100 sec, 2.5 min. A Moll, KLCX, 128 Memory Trail, San Antonio TX 78232. 512-496-0677.

ITC stereo R/P. LJ Maierhofer, WTGC, 101 Armory, Lewisburg PA 17837. 717-523-3271.

ITC 3D mono, all tones, working cond. R Yaw, KOJM, Havre MT 59501. 406-265-7841.

ITC-SP, W Axell, KSAY, POB 2269, Ft Bragg CA 95437. 707-964-5729.

CASSETTE & REEL-TO-REEL RECORDERS

Want to Sell

Tandberg 74B 4 trk, 3 speed, portable case w/tp plastic lid, service & user's manuals, no mics, mint, BO pls shpg; VM 700 portable 1950's consumer unit, fair cond, BO pls shpg. S Delahoyde, Box 33063, Phoenix AZ 85067. 602-937-9088.

Sony TC-755 1/4" 1/4 trk 10" reels, one owner, \$550/trade. J Pines, 217-367-3530.

Tascam 38 1/2" 8 trk, low hrs, excel cond, \$1875; Tascam 40-4 4 trk w/dbx, low hrs, \$925. K Flory, The Production Co, Box 1027, Siloam Springs AR 72761. 501-524-4626.

**M.C.I. RECORDER
P.C.B. REPAIR
Fast Turnaround
K.E.I.
FT. LAUDERDALE, FL.
305-771-2947**

IBM System 34 computer w/70mb hard drive, 6 yrs old, excel cond, used w/Columbine traffic system, \$3500 pls shpg. J Perez, WJLK, 3342 Perry, Camillus NY 13215.

Otari 8 SD 1/2" 8 trk w/calibration tape, extremely clean & reliable +4 or -10 level options, \$2500/BO. M Mantell, 1st Impressions, 15 Perkins, Brockton MA 02401. 508-580-1844.

Scully 280-14SP, mono 14", fair cond, \$250; Kahn Symetra-peak SP 58-1A, gd cond, \$50; SMC 282 time announce, gd cond, BO; CBS Audiomax 4450 stereo, gd cond, \$200; CBS Volumax 4100, mono, excel cond, \$200. J Thomas, WLEW, Bad Axe MI. 517-269-9931.

Scully 280B 2 trk stereo in factory roll-around cabinet, manuals, new heads, spare capstan motor & other parts, excel cond, \$1000 pls shpg. B Mountjoy, WIDD, 610-1/2 Hattie, Elizabethton TN 37644. 615-543-5849.

Stancil Hoffman CRM-7 logger system. M Young, WJON, POB 220, St Cloud MN 56302.

Crown motor, capstan, Dale HMR 50-6, for bi-directional, Crown player, new, BO; Tape-athon 702-7 & 702-10 portable tape players, bi-directional, auto reverse, call for details & prices. E Davison, 135 N Illinois, Springfield IL 62702. 217-787-0800.

Ampex AG-440C 1/2" 4 trk in factory roll-around cabinet, manuals, heads have very little wear, spare set of R/P electronics & other spare parts, vgc, \$1000 pls shpg. B Mountjoy, WIDD, 610-1/2 Hattie, Elizabethton TN 37644. 615-543-5849.

**STUDER
REVOX
FACTORY AUTHORIZED
SERVICE CENTER
"SUPERLATIVE SERVICE"**

Swiss trained in servicing A77, B77, A700, PR99, A67, B67, A810, A807, B710, A710 & C270. Fast 48-72 hour service w/90 day warranty. Huge parts inventory. VISA/MC. New & used machines available.

STUDIO-SONICS CORP.
2246 N. Palmer Dr. #100
Schaumburg, IL 60173
(312) 843-7400

Technics 1520 isolated loop R/P wiremotor control in fair cond, \$500. R Sanchez, KUCV, POB 83111, Lincoln NE 68501. 402-472-3611.

Scully 270-2 (2) 14" stereo rack mt reproducers, 3.75-7.5 ips; also (6) new Scully capstan motors, BO; Ampex 350 stereo PB only w/Schafer elect, excel cond, many spare heads, parts, relays for 350 & 440B decks, BO; PR&E Multisync MDA motor drive variable speed amp for Ampex & Scully decks, BO. B Royster, KOM, 1019 Cordova, San Diego CA 92107. 619-223-3413.

Telefunken M15A 24/32 trk 15/30 w/autolctr & varispd, \$25K; Telefunken M15A 2 trk 7.5/15, \$4K; Tascam 80-8 w/dbx rack mt, \$1100; Nakamichi 550, BO. R Rhodes, POB 1550, NYNY 10101. 212-245-5045.

Pioneer CT-F2121 stereo (2), look gd, may need minor repair, \$60 ea or \$100/both. J Sigmon, WBZK, POB 398, York SC 29745. 803-684-4241.

ITC 850 Series, gd cond, BO. D Wolfe, KRIX, 901 E Pike Blvd, Weslaco TX 78596. 512-968-1548.

Ampex AG 440B 2 trk, 7.5-15 ips in Ruslang console (2), \$700; Ampex 351-2 2 trk 7.1-15 ips w/Inovonics 360 electronics in Ruslang console (2), \$400; Ampex 351 FT 7.5-15 ips in Ruslang console, \$250; Ampex 351 elect (4), \$100. B Reider, WGUC, 1223 Central Pkwy, Cincinnati OH 45214. 513-556-4444.

Scully 280B 4 trk 1/2" in factory roll-around cabinet, manuals, new heads, spare capstan motor & other parts, excel cond, \$1200 pls shpg. B Mountjoy, WIDD, 610-1/2 Hattie, Elizabethton TN 37644. 615-543-5849.

Ampex 350 FT w/Inovonics elect in roll around walnut floor cabinets (2), \$800 ea; Scully 280B 4 trk 1/2" recorder, gd cond, in roll around floor console, \$1795. G Liebisich, WPTF, POB 29521, Raleigh NC 27626. 919-876-0674.

Pioneer 1020L 10.5" reels & (8) reels of tape, stereo 1/4 trk w/qud repro capability (4th), excel cond, \$400. B Ford, Spunk Prod, Box 1052, El Granada CA 94018. 415-726-4786.

Ampex AG500-2 stereo 2 trk, in case, built in mic/line mixing w/plugs, mic preamps, vgc, 7.5-3.75 ips, \$300 plus shpg. M Saady, First City Recd, 141-60 84 Rd 3E, Briarwood NY 11735. 718-846-2062.

Otari ARS-1000 (5), \$1200; MCI JH-110B PB only (2), \$1800; MCI JH-110C mono, \$1800; Otari 5050III 8 trk, \$3200. C Green, Century 21 Programming. 800-937-2100.

Scully 280-1 (2), ea in Ruslang roll-around cabinets w/overbridge, \$3000/pr; (4) Scully 270-2 stereo PB, late mdls, manual, \$3K/all; Ampex AG440B elect chassis, as-is, \$100; Telex 4-chnl, slow-speed logger system, current mdl, \$2000/all; Tape-A-Thon Programmer III, current mdl, \$5000. E Stolz, KWOD, 1425 River Park, Sacramento CA 95815. 916-929-5000.

Scully 255 reproducer, 1/2 trk, stereo, BO. KDKB, POB 6184, Kingman AZ 86402. 602-753-KDKB.

Ampex 350, 7.5-15 ips, FT, cabinet mounted, \$400; Teac A1200, complete, cond unknown, \$100/BO. J McDonald, 303-669-3442.

**THE HALL
Electronics**
**THE BEST DEALS ON QUALITY
REBUILT & BRAND NEW
BROADCAST EQUIPMENT**
We BUY & TRADE equipment too!
Please phone or send for our latest flyer.

10:00AM-6:00PM EST
804-974-6466 1305-F Seminole Trail
FAX 804-974-6450 Charlottesville, VA 22901

Crown 700 1/2 trk stereo portable, excel cond, \$250; Ampex 602 FT, mono, \$100; Ampex 440 1/2 trk, stereo, excel cond, \$1000. W Kremer, 301 SW 16th, Ft Lauderdale FL 33315. 305-524-5652.

Sony PCM -701-ES digital 2 trk processor/recorder use w/any VCR, \$1500/firm. B Ford, Spunk Prod, POB 1052, El Granada CA 94018. 415-726-4786.

AEI 700A continuous loop tape machines (2), \$700 ea/BO. Jim or David, 407-778-5192.

Scully 280 solid state elect, block letters, excel cond, \$150 ea; Scully heads, 4-chnl 1/2" stack w/Amphenol end cables, excel cond, \$170; Scully 280 pwr supply cube, excel cond, \$75; Scully reel motors w/disc brake assemblies & solenoids, excel cond, \$100 ea; Scully capstan motor, 7.5-15 ips, excel cond, \$75. J Newman, 404-239-8046.

Sony PCM-701 ES, 16 bit digital processor, use w/VCR, digital masters similar to PCM-F1 but is AC only, never used, \$1500. B Ford, Spunk Prod, Box 1052, El Granada CA 94018. 415-726-4786.

Ampex 602 & 622 recorder & separate speaker/amp, excel cond except PB head has developed an open circuit, \$100. A Smith, 25 Stonehedge, Lincoln MA 01773. 508-841-2209.

ITC 750 (3) PB R-R, just rebuilt, \$600 ea or \$1500/all. M Harris, WNND, POB 549, Fuquay-Varina NC 27526. 919-552-2263.

Magnecord P-90 in fair cond, BO; Telex 1422, needs motor to operate at slower speeds, BO; Ampex AG600 portable, fair cond, BO. J Keller, WKOK, POB 1070, Sunbury PA 17801. 717-286-5838.

Ampex 440 FT in console, hardly used, \$1500. B Blynder, TVA Inc, 11024 SW 112 Ave, Miami FL 33178. 305-595-9898.

Pioneer 2044 & 2022, Teac 2-A pro 4-trk, 4 chnl or change plug in heads for 2 trk, Teac 2-A mixer 6x4x2, 1/2 trk heads never used, like new cond, \$1800/all. R Coates, Lakes Recdng, 110 W 11th, Spencer IA 51301. 712-262-3113.

Pioneer RT1020L 2 speed 10.5" reels, 14 trk R/P w/4 trk repro head, excel cond, \$400. B Ford, POB 1052, El Granada CA 94018. 415-726-4786.

Otari DP-4050-OCF duplicator, like new, never used; Ampex tube stereo elect for 350 deck; Ampex 350 stereo headstack assembly; (2)

MCI SH110 tape recorder stereo 2 trk; MCI SH110-A tape recorder stereo 2 trk. Kinura Records, Box 660236, Miami Springs FL 33166. 305-887-5329.

Ampex MM1000 16 trk 2" recorder w/remote, \$6000; Technics 1520 2 trk mix down, 1/4", \$1000, both in excel cond. J Maestro, FM Studios, 1351 Brook, Bayshore NY 11706. 516-666-4560.

Revox PR-99 (4) w/Persons Programmer 3A, mint cond, BO. J Phillips, WZOM, 409-1/2 Clinton, Defiance OH 43512. 419-784-1059.

Tascam 122 fairly new, \$600. E Trevino, KBOR, Box 3407, Brownsville TX 78523. 512-541-6348.

Ampex ATR 800 (6) 1/4" stereo R/P, excel cond, manuals, \$2400 ea or \$13,000/all or BO. V Kilion, KRVN, POB 880, Lexington NE 68850. 308-324-6717.

**CLEAN PATCH BAYS
NO DOWN TIME**



**VERTIGO BURNISHERS AND INJECTORS
RESTORE ORIGINAL PERFORMANCE
TO YOUR PATCH BAYS**
\$29.95 Ea.
VERTIGO RECORDING SERVICES
12115 Magnolia Blvd #116
North Hollywood,

RECORDERS . . . WTS

Revox B77 excel cond, \$1000/BO. D Johnson, J-Con Ltd, 200 E Racknet Club, Ste 31, Palm Springs CA 92262. 619-323-4399.

Teac X-2000R 10.5" 1/4 trk, 7.5-3.75 ips. dbx, bi-directional 6-head system, auto-locator, 3-motor transport, very low hrs, excel cond, \$1000. G Curry, Int'l Ministries, 4725 Peachtree Corners Circle Ste 250, Norcross GA 30092. 404-449-6766.

Revox A-77 15/75 ips w/Dolby B 2 trk stereo, \$450/BO; Revox B-77, 15/75 ips, excel cond, \$1250/BO. B Henry, KLLK, 12 W Valley, Willets CA 95490. 707-459-1250.

Otari MX5050-4, 1/4" 4 trk, heads just lapped, \$950. B Petrucci, Rouse St Prod, 804 E Old Hickory, Madison TN 37115. 615-868-8516.

Ampex 1200 24 trk matched pair, all the mods, great shape, heads have been lapped, many spares, \$30K/pr, will consider 15K ea breaking set. D Hewitt, Remote Record, Box 334, Lahaska PA 18931. 215-794-5005.

Ampex 601 tape transport, as is, for parts \$30; (3) Rotron 115 V Whisper fans for equipment cooling, \$10 ea or \$25/all. E Welch, Welch Media, POB 1455, Moncks Corner SC 29461. 803-761-7585.

Recordex 33011 cassette duplicator, 1 master & 3 slaves, 16X duplication speed, automatic rewind, erase heads, long-life Viktor record heads, LED level meters, \$700/BO. G Curry, Int'l Ministries, 4725 Peachtree Corners Circle Ste 250, Norcross GA 30092. 404-449-6766.

Ampex and Scully Spare Parts, Accessories, Motor Remanufacturing.

VIF INTERNATIONAL
PO Box 1555
Mtn. View
CA 94042

Direct order line (800) 848-4428
in CA Dial (408) 739-9740
Telex 62922869 ESL UD
FAX: 1-408-739-0809

Sony/MCI JH-110B-2 R-R console tape decks (2), light use, new heads & pinchrollers, slave capable, (2) technical manuals & one remote control, \$2800/ea. B Kozt, KBAY, POB 6616, San Jose CA 95150. 408-370-7377.

Otari 5050B2 7.5 & 1.5 ips 2 trk, less than 1 yr old, excel cond w/manual, \$950/firm. S Mahaffey, Mahaf Prod, 3592 N Delsea Ste 12, Vineland NJ 08360. 609-692-3439.

Otari ARS-1000 in excel cond, (4), \$700 ea. C Knerr, KCNA, 139 SE J St, Grants Pass OR 97526. 503-474-7564.

Scully 1/2 trk tape heads (28) play; (12) mono Magnacord Presto, play; (16) Magnacord stereo lapped Presto, play, sacrifice price. Call 616-782-9258.

Revox tape recorders, top-shape factory rebuilds. New heads, etc. Accessories. A77, \$850; B77 (1/4 trk 7.5 ips), \$1000; G36 (tube mdl) 1/4 trk 7.5 ips, \$500. Send phone number & address to: JM Technical Arts, POB 8156, Hermitage TN 37076.

Ampex AG-440A-I-R, gd cond, \$450; Ampex AG-602-2-p, new, \$775; Ampex PR-10-2-p, very gd cond, \$850; many others, call Martin at 219-322-7090.

Want to Buy

Sony TC 788-4 4 trk in gd cond & w/maintenance manual. C Fuller, Voices, POB 153, LaGrange IL 60525. 312-579-9578.

Tascam 70 4 or 8 trk in working cond, also parts & manuals. R Barrett, Inner City Prod, 5539 E Burnside, Portland OR 97215. 503-234-6225.

Multi-track R-R or porta-studio in gd cond for small market studio, affordable price. Call 314-998-2377 or write: WLD Recdg, W Dougherty Jr, Rt 1, Music Valley, Mill Spring MO 63952.

Teac A7030S6, A7030GSL, A3300SX & broke/poor cond machines for parts. J Parsons Sr, Parsons Elect, 10375 Cannas, N Huntingdon PA 15642. 412-863-9590.

High speed cassette duplicator mono or stereo to record 10 at one time in working cond, need not be Elabrite. R Sweatley, KXXR, 600 Bdw Ste 220, Kansas City MO 64105. 816-421-1065.

ATR100 taperecorders for parts. Circuit cards, heads, motors, machine parts, or electronic parts. Call 818-907-5161.

MCI/Sony capstan & reel motors, any cond., recd heads, most mfgs, machines, new, used. Relapped then sold. Amp Services, 224 Datura St No 614, W Palm Beach FL 33401. 800-826-0601, in FL 305-659-4805.

CONSOLES

Want to Sell

Autogram AC-8/IC-10 spare parts, lamps, switches & bridging input transformers. BO. B Royster, KQM, 1019 Cordova, San Diego CA 92107. 619-223-3413.

Numark DM 1550 4 chnl DJ mixer, 2 phono inputs, 2 line inputs, 2 mic inputs, 6 band graphic EQ, always in road case, excel cond, \$150. B Fisher, KPOK, Box 477, Bowman ND 58623. 701-523-3883.

Allen & Heath Systems 8 16 input, 8 subs, 16 monitors, 3 effect sends, +4 or -10 level options, excel cond, \$3000/BO. M Mantell, 1st Impressions, 15 Perkins, Brockton MA 02401. 508-580-1844.

Gates/Harris Executive 10 chnl stereo solid-state console in clean, vgc w/manuals, \$1000 plus shpg. B Mountjoy, WIDD, 610-1/2 Hattie, Elizabethton TN 37644. 615-543-5849.

RCA 8 pot, gd cond, BO: Cetec 2000 8 pot, 16 input w/pwr supply, gd cond, BO. D Wolfe, KRIX, 901 E Pike Blvd, Weslaco TX 78596. 512-968-1548.

Auditronics Grandson 18 input console, \$3800/BO; Speck 33X16 rcdg console 3-band sweep EQ, patch bay plus 24 tr harness, \$3795/BO. G Freeman, Pranava Prod, 1227 Sierra Alta Way, Los Angeles CA 90069. 213-457-8390.

Gates Stereo 80 complete w/pwr supply, most rotary faders new, works fine, 3 mic input 4 line input, includes book, \$800. C Benner, WUSL, 440 Domino Ln, Philadelphia PA 19128. 215-483-8900.

QRK Omega 10 chnl, all plug-in amps, digital switches, complete set of spare PC boards, \$4500. B Brown, WPRS, POB 367, Paris IL 61944. 217-465-6336.

Ramko DC8M5 8 chnl stereo, excel cond, all manuals & extras, \$5500. R Trumbo, KNFL, POB 117, Quincy CA 95971. 916-283-4144.

Autogram AC-6 6 chnl 23 input stereo, in excel cond, includes ESE built-in timer, \$4200/BO plus shpg. D Kelley, KISZ, POB 740, Cortez CO 81321. 303-565-1212.

Tascam M-50 12x8x8, lots of extra features, low hrs, mint cond, \$2900. K Flory, The Production Co, Box 1027, Siloam Spring AR 72761. 501-524-4626.

SPOTMASTER BROADCAST ELECTRONICS
—PARTS—
and Accessories
SEQUOIA ELECTRONICS

1131 Virginia Ave
Campbell CA 95008
(408) 866-8434

Sphere Eclipse A/B 20x16 w/(8) 9-band graphic EQ, full patch bay, producers desk, \$6000. H Alrich, Box 869, Greenville CA 95947. 916-284-6929.

Ramsa WR 8112, 12x4x2, \$1500. C Green, Century 21 Programming, 800-937-2100.

EV EVT 5212 12 in, stereo out & mono & monitor, mint cond, \$500. D Bailey, 3422 Beech, Rowlett TX 75088. 214-475-9796.

RCA BC5A (2), modified to 7 inputs, complete w/spare parts & manuals, gd cond, BO; Kel-don KD20A remote broadcast console w/(2) TTs, (2) waterproof speakers, gd cond, BO. J Keller, WKOK, POB 1070, Sunbury PA 17801. 717-286-5838.

McCurdy SS-7500 stereo console parts, P&G faders, plug in preamps, etc. J.C. Aegeer, Satcom, 5431 W Center, Milwaukee WI 53210. 414-445-2300.

BE 4BEM 50 w/4 pots; (2) Ramko solid state; Collins 212 F-2 tube type w/6 pots; ATI 8 chnl stereo w/pwr supply, call for details. Adolph, 915-949-2112.

Interface 104L 16x8 monitor mix console, 9 freq, 3 band EQ pads, solos, etc, \$950. B Petrucci, Rouse St Prod, 804 E Old Hickory, Madison TN 37115. 615-868-8516.

Tascam M-520 20 chnls, mint cond, 6 mos old, \$4250. D Miller, Airborne Audio, 11647 W 83rd Terr, Lenexa KS 68214. 913-492-8822.

Sunn Magna 5000, 24 inputs, 4 outputs, 3 aux sends, 3 band, 5 frequency EQ, Duncan faders & (2) spare modules & case, \$2300. B Petrucci, Rouse St Prod, 804 E Old Hickory, Madison TN 37115. 615-868-8516.

Midas Pro Custom Recording, 16x8, Remix switch-over, (8) Pro 5, (8) Pro 3 modules, peak meter, clock/timer, flight case, \$10,500. H Alrich, Box 869, Greenville CA 95947. 916-284-6929.

Harris Micromac 16 input mainframe, manuals, spare pwr supply, \$10,000/BO. V Kilion, KRVN, POB 880, Lexington NE 68850. 308-324-6717.

RCA BC8A dual mono console, clean shape, \$500 plus crating & shipping. J Kreines, DeMott/Kreines Films, 5330 Kennedy, Millbrook AL 36054. 205-285-6179.

Want to Buy

API 550A, 560 EQ's, cash/trade; Neve input modules & compressors, cash/trade. J Pines, 217-367-3530.

RCA BC-7 meter panel. C Gill, POB 371, Indianapolis IN 46206. 317-923-2800.

Auditronics 110 Grandson modules needed, 110IME, 110BIME, 110SSF4, F2R & F1R, any or all, clean, reasonable, cash. D Payne, WZPL, 1440 N Meridian, Indianapolis IN 46202. 317-637-8000.

Auditronics 100 Grandson, need 1 or 2 IME modules & 1 or 2 SPF4 modules. B Larson, WUSN, 875 N Michigan, Chicago IL 60611. 312-649-0099.

Auditronics 110 Grandson, need assorted modules, sell or trade, need pots & input modules. D Payne, WZPL, 1440 N Meridian, Indianapolis IN 46202. 317-637-8000.

Old Hycor passive EQ; Lang PEQ-2. A Aaron, Gannett Outdoor Co, 1695 Eastshore Hwy, Berkeley CA 94710. 415-527-3350.

DISCO & SOUND EQUIPMENT

Want to Sell

Community Light & Snd RS440 4-way speakers (one pair) w/Community VB790 bass bins, in Anvil cases, excel cond, \$2200 plus shpg. J Kreines, 5330 Kennedy, Millbrook AL 36054. 205-285-6179.

Remodeling 8 studios, all boards, TT's, Scully R-R's & misc equip now avail in gd cond, call for detailed list & low prices. J Ballard, 213-659-5779.

Arp 2600 Odyssey electr synthesizer, \$300. F Vobbe, Great Northern Bdct Co, POB 5031, Lima OH 45802. FidoNet 1:234/16.

Delta Lab Electron II digital delay & special effects, rack mt, excel cond, \$350/trade for EC RE20 mic. T Crockett, Hot Tracks, Box 10501, Blacksburg VA 24060. 703-953-0222.

Cross-overs (10) including (4) JBL 5234; Bi-Amp SM23; plus 5 more, sell all or individually, BO. D Keller, Keller Bdctg, 8700 Chellenham, Wyndomore PA 19118. 215-233-5401.

JBL 4311 control monitors, walnut, excel cond, \$400/pr. R Treat, 38 Blue Pond PO56, Scottsville NY 14546. 716-887-4973.

Community Light & Sound RS440 4-way speakers (pair) w/Community VB790 bass bins, in Anvil cases, excel cond, \$2200 plus shpg. J Kreines, DeMott/Kreines Films, 5330 Kennedy, Millbrook AL 36054. 205-285-6179.

JBL 4315, 4333, 4343 monitors in gd cond. R Cobb, Solid State Svc, POB 5332, Sun City FL 33571. 813-634-1940.

Digital delay or digital reverb for small market recd studio, affordable price. Write WLD Recdg, W Dougherty Jr, Rt 1, Music Valley, Mill Spring MO 63952.

LIMITERS

Want to Sell

UREI 1176 LN excel cond, schematic, silver face mdl w/LN module installed at factory, \$300. R Jordan Jr, Southland Recdg & Snd, 812 Young, Selma AL 36701. 205-874-8009.

Audio & Designs vocal stressor 4 band EQ & compressor, limiter, noise gate at same time, vgc, \$1100; Programming Technologies Ecoplate2, excel cond, \$650/trade. J Pines, 217-367-3530.

EASY NR SC

A "post-processor" for REAL AM Improvement! Simply connect it between your existing limiter and the transmitter for "protected" pre-emphasis and overshoot-controlled lowpass filtering to NRSC specs.

Inovonics
SANTA CRUZ, CA (408) 458-0552

Aphex Aural Exciter Type B in excel cond, \$100/BO. R Pollard, KSKG, 1217 S Santa Fe, Salina KS 67401. 913-825-4631.

RCA BA-6A tube limiter, rack mnt, vgc, \$450/trade. J Pines, 217-367-3530.

CRL APP 400, PMC 300A, SEP 400B, SPF 300, in service, 2.5 yrs old, vgc, in use, avail 30 days, \$2700. M Tracy, KOAQ, POB 1263, Scottsbluff NE 69361. 308-635-2690.

Trade new Valley Intl Gain Brain 2 for Valley Intl Maxi-Q. J Pines, 217-367-3530.

PR&E Multilimiter FM/AM, new matched stereo pairs, also AM Multilimiter, \$250 ea; Orban 418A stereo compressor/limiter, switchable pre-emphasis, front end of 8000A, BO; CBS Labs 410, 411, 4300, excel cond; (2) new CBS Labs dynamic presence EQ's, slimline, \$100 ea. B Royster, KQM, 1019 Cordova, San Diego CA 92107. 619-223-3413.

CRL FM System including SPP-800, SEP-800, SMP-800, SG-800 & CC-300A, \$4500; Orban Optimod 8000A, excel cond, \$1800. B Musser, WMID, Ohio & Murray, Atlantic City NJ 08401. 609-344-5113.

CBS Audimax 4450, BO; CRL APP 300, BO; (2) CBS Volumax 411, BO. KDKB, POB 6184, Kingman AZ 86402. 602-753-KDKB.

Urei BL 40 mod/limiter, \$295. K Crosthwait, WTNN, 13206 Buttermilk, Knoxville TN 37932. 615-531-2297.

Orban 8000A Optimod, works perfectly, \$1800. K Reising, WRZQ, POB 690, Columbus IN 47202. 812-379-1077.

Modulation Sciences CP-803 (2) new composite clippers, \$950. R Jesse, KLTQ, 3645 South, Springfield MO 65807. 417-887-9650.

CBS Labs stereo limiter, 1 side chnl not working; Universal Audio BL-40 Modulimiter. Adolph, 915-949-2112.

CRL CC-300 composite controller, works fine w/documentation, \$350. E Schechter, KMLE, 645 E Missouri Ave, Phoenix AZ 85012. 602-264-0108.

Want to Buy

CBS Volumax 400 manual, copy OK if legible & schematics included, will copy your manual & return it, will pay postage both directions. T Wheeler, RR1 Box 215, Carlock IL 61725. 309-378-7721.

Fairchild 660 tube, fair price/trade; Aphex/B&B CH-1 compressor/noise gates, cash or trades. J Pines, 217-367-3530.

Orban 8000A Optimod, new or used, preferably refurbished, price negotiable. J Schindler, Family Stations, 290 Hegenberger, Oakland CA 94621. 415-568-6200 X240.

Audimax & Volumax, any cond, junk to excel, call or write w/lowest prices. T Crockett, Hot Tracks, Box 10501, Blacksburg VA 24060. 703-953-0222.

Tube limiters, compressors & EQs, especially Fairchild 660 & 670, Teletonix LA2a, LA3, any Pultec EQs, Lang EQs, etc; also need other vintage tube signal processing equip. J Kreines, DeMott/Kreines Films, 5330 Kennedy, Millbrook AL 36054. 205-285-6179.

MICROPHONES

Want to Sell

Neumann TLM-170, new, blk finish, \$1250/trade; AKG D-1000E, vgc, \$75. J Pines, 217-367-3530.

RCA 44, \$750; Sony AC148A 2 mic pwr supply, BO. R Rhodes, POB 1550, Nyny 10101. 212-245-5045.

RCA SK-46 program velocity ribbon, new, \$325. D Miller, Airborne Audio, 11647 W 83rd Terr, Lenexa KS 66214. 913-492-8822.

AKG C-60 tube condenser mic systems, mint, tube 451E w/AC701K w/cardioid capsules, pwr supply & cables (4), 2 pairs, will trade, \$800/pr or \$1525/all. J Pines, 217-367-3530.

Sony ECM-30 condenser lavalier in box, BO. B Royster, KQM, 1019 Cordova, San Diego CA 92107. 619-223-3413.

AKG 451E (2) w/AGK pwr supply, \$450/pr. R Sanchez, KUCV, POB 83111, Lincoln NE 68501. 402-472-3611.

Sennheiser MKH815, \$500 & MKH 816, \$575, shotguns w/foam windscreen in mint cond. D Scales, Scales Film Snd, 3142 Market Pl, Bloomington IN 47403. 812-339-4446.

EV 635A omni dynamic, excel cond, w/clamp, \$40 plus shpg. M Saady, First City Recd, 141-60 84 Rd, 3E, Briarwood NY 11735. 718-846-2062.

Sony C-55P (3) very rare, mint cond, FET condenser, tiltable capsule for front or side pick-up, w/case, mic holder screen, \$500/BO. J Diamond, Box 102C Chubbic, Canonsburg PA 15317. 412-746-3455.

Shure 5B, antique ring & spring type w/table stand, gd cond, \$385. R Cane, 6142 Miramar Pkwy, Miramar FL 32023. 305-962-8111.

Neumann U47let (2), mint cond, w/leather box, warranty, \$995/ea. Klaus Heyne, 415-664-0163.

Neumann KMR 82 shotgun, like new, leather case & windscreen, \$650. D Scales, Scales Film Snd, 3142 Market Pl, Bloomington IN 47403. 812-339-4446.

Nady 501 VRLT wireless mics (2) w/lav body packs, 185.15 & 215.15 MHz, \$800/both. TFG, Box 9, Wethersfield CT 06109. 203-527-2972.

Vega R-41 wireless w/Dynex II, like new, \$1500. D Scales, Scales Film Snd, 3142 Market Pl, Bloomington IN 47403. 812-339-4446.

Neumann U-47 Nuvisor (2), Kinura Records, Box 660236, Miami Springs FL 33166. 305-887-5329.

B&K Omni mic, w/AK accessories, never used, still in wooden case, \$1000. B Ford, Spunk Prod, Box 1052, El Granada CA 94018. 415-726-4786.

Vega 66 RCV-77TX (2) wireless w/Dynex II, gd cond, \$1000 ea. D Scales, Scales Film Snd, 3142 Market Pl, Bloomington IN 47403. 812-339-4446.

AKG DD202E (4) w/clips, vgc, (2) w/case, \$100 ea. M Rice, WKBO, 2360 Hampton, St Louis MO 63139. 314-644-1380.

Sennheiser MD421, (2) w/boxes; RCA 77, perfect pair, matched w/original bags, BO. J Phillips, WZOM, 409-1/2 Clinton, Defiance OH 43512. 419-784-1059/

Audio Technica all models, call. K Taylor, Image Support, 103 N Aspen, Sterling VA 22170. 301-864-4841.

RCA ribbon mics including (1) 44BX, \$500; (1) 77D, \$400; BK-11, \$400; 74-B, \$250; (2) SK-46, \$250 ea; Shure 330 ribbon, \$250; Dynamics (2) Shure 555W, \$60 ea; EV 611, \$50; EV 630, \$25; Astatic DN-HZ, \$180. Tracy Eaves, 615-821-6099 (evenings).

Want to Buy

Neumann KM-56, U-64, U47, M-50, M-250, AKG C-12, c-12A, C-24, C-28, Telefunken U-47, ELAM-251, KM-56, trade of cash for gd cond. J Pines, 217-367-3530.

Vintage ribbon mics, RCA 77s/44s & tube condenser mics, especially Neumann/Telefunken. Jes, 5330 Kennedy, Millbrook AL 36054. 205-285-6179.

Any condenser shotgun in working cond, prefer Sennheiser or AKG but interested in others. H Biller, 125 Lee Ste 2, Takoma Pk MD 20912. 301-270-1448.

Old mikes, WE, Altec 630, 633, 670, Shure 556, SM-33, 300, any Amperite, American D-33, DR-330, RCA Velocity Jr, Turner 9A, working or not. D Igou, KGNB, 1540 Loop 337 N, New Braunfels TX 78130. 512-625-7311.

RCA 77's, 44's, Neumann 47's, 87's, will purchase or trade R-R's or TT's. W Kremer, 301 SW 16th, Ft Lauderdale FL 33315. 305-524-5652.

RCA, JBL Mod 1-0001 RCA ribbon mic, mod 4311B, studio monitor loudspeaker (1). RL McDonald, 5231 Horton, Mission KS 66202. 913-722-2677.

Vintage tube condenser mics, especially Neumann, Telefunken, Schoeps, AKG & classic ribbon mics, RCA 77s/44s. J Kreines, DeMott/Kreines Films, 5330 Kennedy, Millbrook AL 36054. 205-285-617

MISCELLANEOUS . . . WTS

Extel AL Series, like new, will trade for cart machines, Marti equip or, etc. BO. A Moll, KLXQ, 828 S Getty, Vualde TX 78801. 512-278-1102.

Stancil Hoffman CRM-7 logger system. M Young, WJON, POB 220, St Cloud MN 56302. 612-251-4422.

Rare vintage bdct equip: RCA console, mics, TT, speakers, varied other items, all in working order. T Heathwood, Heritage Radio, POB 16, Boston MA 02167. 617-969-1746.

Excess wire & cable inventory, Belden types 8449, 6447, 8790, 8422, 8459, 9750, 8448, 8663, 8627; control cable, microphone cable, bonding cable, various lengths, some spooled, some rolls, all new, you ship. R Ker-bawy, WTNJ, Box 1127, Beckley WV 25802. 304-877-5592.

Patch panels (7), 4 stereo TRS, 3 mono double plug type. BO; 25 Hz tone gen, missing cover, no instructions, 3.5" rack mount, remote controllable, BO. P Hess, 134 Derwent Dr, Pgh PA 15237. 412-366-1249.

Misc equip racks, call for details, Adolph, 915-949-2112.

Large amount of misc furniture/furnishings including steel/padded vinyl chairs, kitchen table, desks, R-R stands, lamps etc., call for more details. Adolph, 915-949-2112.

Toshiba 720K 35" disk drive w/mounting kit to use in 5-1/4" slot, new sealed in box, \$80. M Peterson, 3610 Lancaster Ste 6, Plymouth MN 55441. 612-544-6391.

Various pieces of equip including Fisher audio component system; TT's; table top lazy susan; xmtr breaker box; on-air lights; Extel 1A1 11 R printer w/stand & book, Multilith off-set mdl 65, GE AP printer, stands, etc, call for details. Adolph, 915-949-2112.

Bdct Development Group, Don Werlinger, if you have had towers erected or equip installed by the above, I would like to hear from you. Chuck, 919-623-9966.

Phasemaster T-7500-A2 240V single phase to three phase rotary phase converter, 1 yr old, \$3500. D Quinlan, KLAD, 1020 Pine, Klamath Falls OR 97801. 503-882-8833.

RCA equip manual from 1967; boards; xmtrs, excel cond, \$25. D Miller, Airborne Audio, 11647 W 83rd Terr, Lenexa KS 66213. 913-492-8822.

Want to Buy

Harris, RCA, Allied, etc. product catalogs; 4th & 6th editions of NAB Engineering Handbooks. C Gill, POB 371, Indianapolis IN 46206. 317-923-2800.

111-C coils (4) needed. L Thomas, KMTC, POB C, Russellville AR 72801.

RCA On-Air lights, QKI telephone interface. K Anderson, 2358 S Man St, Salt Lake City UT 84115. 801-466-3196.

VPI HW-17 record cleaning machine. D Weston, KCOP, 5922 W 76th, Los Angeles CA 90045. 213-216-7814.

Pre 1960 bdct equip magazines, catalogs, instruction manuals, 7" & 10" blank recording discs, RCA & WE studio equip. R Van Dyke, 2 Squires, E Quogue NY 11942.

Equip rack-cabinet or open type, Chicago area pick up only. William, Lectrotech, 5810 N Western, Chicago IL 60659. 312-769-6262.

Jazz record collections, 10" LP/12" LP bebop, swing, dixie, highest prices paid. B Rose, Program Recdgs, 228 East 10th, NNYN 10003. 212-674-3060.

MONITORS

Want to Sell

Jennings RB7-A vacuum relay, 7 KV, 14 A DPDT, \$120. J Cunningham, KHKC, Rt 2 Box 113B, Stonewall OK 74871. 405-265-4496.

TFT 730A 2.5 yrs old, SCA mon, excel cond, \$1000. D Starkey, WVHF, POB 2423, Clarksville WV 26301. 304-624-5525.

McMartin TBM-3500 mod mon, BO, KDKB, POB 6184, Kingman AZ 86402. 602-753-KDKB.

McMartin EBS 2 monitor, needs new filter, BO; McMartin TG2 EBS tone gen, gd cond, BO. J Keller, WKOK, POB 1070, Sunbury PA 17801. 717-266-5838.

Gates GTM-88R FM RF amp, working when removed, \$100. R Huceby, KJLF, POB 336, Butte MT 59703. 406-723-4006.

Nems-Clarke 8 tower phase monitor, \$300. F Vobbe, Great Northern Bdct Co, POB 5031, Lima OH 45802. FidoNet 1:234/16.

Want to Buy

Manuals & parts for McMartin TBM 3000 & TBM 3000A freq mon; TBM 3500 & TBM 3700 mod mon; TBM 2200 stereo mod mon; TM 45-T remote metering panel. C Gill, POB 371, Indianapolis IN 46206. 317-923-2800.

FM mod mon, working or repairable, reasonably priced for subsequent donation to classical station, older unit OK. E Reihl, 1715 Illinois, Northbrook IL 60062. 312-272-7125.

Belar FMMI, FMSI, SCAI, RFAL, gd cond. J Phillips, WZOM, 409-1/2 Clinton, Defiance OH 43512. 419-784-1059.

Potomac AM 19(204) antenna monitor for 4 tower array needed ASAP. G Sies, WRYT, 9 Cougar, Edwardsville IL 62025. 618-692-9798.

Belar or TFT FM mod monitor, stereo, preferably w/freq monitor, also need crystal 963; Wegener SMN receiver frame w/format cards for sat mys network, splitter 1601. LJ Maierhofer, WTGC, 101 Armory, Lewisburg PA 17837. 717-523-3271.

MOVIE PROD EQUIP

Want to Sell

Eiki SL-0 16mm slot load projector, \$450; Maurer 05 body, 3 mags, no motor, \$750; B&H 70 DR w/Anvil case, 1" Comat, instructions, \$325. J Kreines, 5330 Kennedy, Millbrook AL 36054. 205-285-6179.

New Eiki SL-0 16mm slot load projector, \$450; Maurer 05 body, 4 mags, no motor, \$750; new Bell & Howell 70 DR w/Anvil case, 1" Comat, instructions, \$325. J Kreines, DeMott/Kreines Films, 5330 Kennedy, Millbrook AL 36054. 205-285-6179.

Want to Buy

Arriflex S Model camera & any accessories wanted for Arri-S; also C mount lenses & editing equipment. H Biller, 125 Lee Ave Ste 2, Takoma Pk MD 20912. 301-270-1448.

Mitchell 35 & 16mm cameras & access, other prof 16/35mm cameras, Zeiss 9.5mm Distagon, reasonable, need not be mech mint. J Kreines, 5330 Kennedy, Millbrook AL 36054. 205-285-6179.

Mitchell 35 & 16mm cameras & access; other professional 16/35mm cameras; Upright Moviolas, especially 35mm; Westrex 35mm optical recorders; Zeiss 9.5mm Distagon, reasonable, need not be mechanically mint. J Kreines, DeMott/Kreines Films, 5330 Kennedy, Millbrook AL 36054. 205-285-6179.

RECEIVERS & TRANSCEIVERS

Want to Sell

Johnson ST-4A SCA rcvrs (2) less X-tals, tested, \$50 ea/BO pls shpg. K Smith, 118 Barstow, Gorham ME 04038. 207-892-8776.

GE portable units wchargers (2); Motorola base unit; base antenna, all 26 MHz band; CB base antenna; (2) RCA stereo TT EQ preamps, look similar to BA 26B. H. Canada, WHOOD, 1 Radio WHOOD Rd, Orlando FL 32808. 407-295-3990.

ICOM IC 02AT hand held rec & trx, 140.400-162.900 programmable, tone encoder, 38 tones 67.0-250.3 all std equip includes book & shipping carton, new cond, \$300. B Boyer, WMOP, POB 3930, Ocala FL 32678. 904-732-2010.

Microdyne 1100-FFC-X1-RD(R) SSCP rcvr, also Cal Microwave demod shell & Mod Associates cue alarm, \$800/all. S Icenogle, KTRS, 251 W 1st, Casper WY 82601. 307-235-7000.

Motorola Pulsar mobile telephone 20 W all VHF chnl's includes control head, antenna, cables & manual, \$400. D Bailey, 3422 Beech, Rowlett TX 75088. 214-475-9796.

WE'VE DONE THE HARD PART

Our new program computes TV & FM Field Strength for you. It uses the FCC algorithm to determine distance to contour, field strength at distance, and bearings between coordinate pairs. It runs on any IBM-PC compatible and incorporates FCC Docket 88-56 rules. Only \$95.00

Jeremy Lansman Spectrum Resources POB 240-467 Anchorage AK 99524 (907) 345-2630

RCA Super Controltone 500 UHF repeater crystalized on 464.3 MHz transmit, 469.3 MHz receive, in weather tight rack cabinet w/Decibel DB472 6 cavity duplexer, Decibel DB-410 16 bay high gain antenna w/mounting clamps & approx 160' of 5/8" hardline w/con-nectors, \$900/system or will break up pieces. M Peterson, 3610 Lancaster, Ste 6, Plymouth MN 55441. 612-544-6391.

Want to Buy

Aerotron 7N20 44-54 MHz 12 W FM radio, need manual or schematic, also units for parts/operation. M Starin, WJYY, 457 Varney, Manchester NH 03102. 603-625-1165.

25-50 MHz FM monitor rcvr tube types preferred, crystal-controlled. M Starin, WJYY, 457 Varney, Manchester NH 03102. 603-625-1165.

GE ET-72A/ER-46A Executive 30 W FM radio, need manual or schematic, also units for parts/operation. M Starin, WJYY, 457 Varney, Manchester NH 03102. 603-625-1165.

Sequerra 1 FM tuner w/scope, working cond only, also service manual. P Madnick, DTG, 5743 Corsa Ste 207, Westlake Village CA 91362. 818-706-3338.

McKay/Dymek AM-10, 8, 7 AM tuner, wide band, working cond only, also service manual. P Madnick, DTG, 5743 Corsa Ste 207, Westlake Village CA 91362. 818-706-3338.

Motorola 2-way radios to be used on my repeater freq, 462.675 & 467.675, list avail radios & write. C Hoffman, 251 174 St, Ste 404, Miami Beach FL 33160.

Group home radio club needs ham receiver & xmtr, USB, DSB, LSB, LW, must be gd cond, call or write, I Dewchowitz, WHBI, 696 Wood, Avenel NJ 07001. 201-602-1242.

Scientific Atlanta 7300 dual 7.5 kHz audio card. T Shinn, WKSF, POB 6447, Asheville NC 28816. 704-257-2700.

Manual for R-391 receiver. S Daitch, PSC 1 Box 362, APO San Francisco 96286.

Used EBS receiver in working cond. S Kile, Keckman Inst., 10493 Dupont Rd, Bloomington MN 55431. 612-888-1627.

REMOTE & MICROWAVE EQUIP

Want to Sell

TFT 7610 digital remote control system, configured for 4 wire operation, in service, 5 yrs old. P Bailion, 612-222-5555.

Marti STL-8 (2) xmtrs, (2) rcvrs, xmtr combiner, rcvr combiner, in gd cond, \$2600/BO. R Pollard, KSKG, 1217 S Santa Fe, Salina KS 67401. 913-825-4631.

Fairchild Dart 384 7.5 kHz dual program card, excel cond, \$675. D Kelley, KLSZ, POB 740, Cortez CO 81321. 303-565-1212.

Drake ESR 2240 satellite rcvr, receives audio & video signals. P Bailion, 612-222-5555.

Moseley PCL-101 STL system, crystalized at 950.000 MHz, operational when removed, no manual, \$1050/firm, pre-paid, UPS, insured. D Peluso, KFM, POB 15223, Las Vegas NV 89114. 702-732-7753.

Moseley SCS-2, status control system for phone line & new TSK-3 temperature sensing kit; also spare parts kits for PCL-303/C, 505/C & TRC15 remote control, BO; McMartin TBM-250C (2) FM RF amps & pre-selector; rack mount fixed tuned AM rcvr, BO. B Royster, KOM, 1019 Cordova, San Diego CA 92107. 619-223-3413.

Harris SCA gen card for MX-15 exciter, BO; Moseley SCG-4T sub-carrier gen, BO, KDKB, POB 6184, Kingman AZ 86402. 602-753-KDKB.

Secode DTMF 5 chnl decoders (2), Vega data control telemetry system includes XMTR & rec units, FS keying, BO. R Juckey, KJLF, POB 336, Butte MT 59703. 406-723-4006.

** BAX **

FOR SALE OR RENT

C.N. ROOD 5KHz Bandwidth Extension System turns Phone Lines into Music Lines

Exclusive No. Am. Reps

MARCOM

408-438-4273

Moseley TRC-15AW (2) complete systems, working when removed, telephone line, can be converted for STL, \$1000/BO ea. R Huceby, KJLF, POB 336, Butte MT 59703. 406-723-4006.

Wegner satellite rcvr & decoder for SMN, country & Starstation (AC) formats, includes all the electry you'll need for both, plus auto-lock switchers for both formats, \$3200/all. D Silver, KNKK, Layton Hills Mall, Layton UT 84041. 801-973-7759.

QEI 7775 ATS, will sacrifice. BO. J Katz, KJUG, 717 N Mooney, Tulare CA 93274. 209-686-2866.

Fairchild Dart 15 kHz card, fits Fairchild Dart 384 receiver, call for price. P Bailion, 612-222-5555.

Data Signal MTI-700 modular telephone interface, BO. KDKB, POB 6184, Kingman AZ 86402. 602-753-KDKB.

Scientific Atlanta 7300 2.8m dish, 120K LNA, 7300 BPSK rcvr, 7325 DPU, 15 kHz card, 7.5 kHz card, 3 kHz card, vgc, 19-23-3-15 crystals, typical Westwood 1 set-up, \$7000. M Lehmth, WSNL, 1944 Innerbelt Bus Ctr Dr, Overland MO 63114. 314-426-0101.

Marti STL-8 xmtrs/rcvrs (2), tuned to 950.375/950.625 MHz; HRC-8 xmtr combiner, rcv combiner, cables & books, recently removed from srvc, ready to ship, \$2800/BO pls shpg. L Ayer, KPRL, POB 8849, Moscow ID 63843. 208-682-2551.

Marti STL-8 (2) xmtrs & rcvrs, 946.850 & 947.150 MHz, \$2000/BO. B Stuart, KSUE, 3015 Johnstonville Rd, Susanville CA 96130. 916-257-2121.

LAUX satellite system, to be sold as package only, call for details; Harris satellite system also to be sold as package, call for more info. Adolph, 915-949-2112.

Moseley TRC-15AW recently removed from srvc. JR Curtis, KAEZ, POB 4299, Longview TX 75606. 214-663-3700.

TFT 7601 configured for 110 kHz/67 kHz operation or 2 wire telco, works great w/manual, \$1800/BO; Moseley 505C presently on 945.5 MHz, older version, works well, needs some alignment, will consider trade for Marti RPU gear, \$1500/BO. E Schecter, KMLE, 645 E Missouri Ave, Phoenix AZ 85012. 602-264-0108.

Short haul xmtr remote control, home brew, straight forward circuit, controls & meters, one xmtr over 4 pair wire, \$150/BO. D Carver, KZBK, 107 S Main, Brookfield MO 64628. 816-258-7458.

Ringo Ranger II on 161.70 MHz & Ringo Ranger II on 450.950 MHz, used on temporary installation, includes documentation, mounting hardware, \$20 ea or \$35/both. F Vobbe, Great Northern Bdct Co, POB 5031, Lima OH 45802. FidoNet 1:234/16.

CRL SCA 330A, new in box, tested but not used, BO. D Laustsen, Sunset Comm, 19 Meadow, Doylestown PA 18901. 215-340-9738.

Marti SCG-10 subcarrier gen tuned to 92 kHz, 7 mos old, \$1000. A Matos, WRFE, Box 846, Aguada PR 00602. 809-868-7793.

Want to Buy

Complete satellite system, dish down-converter, receiver-demod & audio program chnl for SATCOM 1R, transponder 23, 15 kHz digital chnl, must be compatible w/present digital format. B Stuart, KSUE, 3015 Johnstonville, Susanville CA 96130. 916-257-2121.

Marti RPT-15 or RPT-30 for sports broadcasts, prefer UHF. P Bailion, 612-222-5555.

Marti STL-10 need (2) w/manuals. M McVey, 620 Lake Rd, Ottamwa IA 52501. 515-682-0498.

Moseley PCL606-C composite STL, excel cond, \$5900. C Kner, KCNA, 139 SE J St, Grants Pass OR 97526. 503-474-7564.

Marti RPT-15 or RPT-30 for sports bdcts, UHF. P Bailion, 612-222-5555.

Moseley PCL-505 STL. W Axell, KSAY, POB 2269, Ft Bragg CA 95437. 707-964-5729.

Harris Sentinel 16 needed ASAP. G Sies, WRYT, 9 Cougar, Edwardsville IL 62025. 618-692-9798.

STATIONS

Want to Sell

Class A FM & 10 kW AM daytimer w/PSA priced for quick sale in Price UT. J Dart, 801-637-0863 or 1752 for details.

1 kW AM on 1580 kHz, authorized for FT in a city of approx 15,000, less than 3 percent unemployment & only one other locally operated station, 1 hr So of Nashville, excel opportunity for owner and/or mgmt team, 200K cash or will consider reasonable cash offer. A Wilkerson, WLIL, POB 340, Lenoir City TN 37771. 615-986-7536.

Large AM construction permit in the West, located in major market area, great night time coverage. C Hall, KRDA, 2207 S Nevada, Provo UT 84606. 801-374-6809.

Hot Daytimer, New York State for sale 75% to sales mgr-operator, long time pro-operator mgr stays negotiable. G Dacre, WTBQ, 62 Main, Florida NY 10921. 914-651-4446.

Selling equity interest in AM located in dynamic growing southern Utah community, turn around opportunity has been successful but under capitalized, principles only. M Skinner, 341 S Bluff, St George UT 84770. 801-628-1000 inquiries confidential.

Mid-Michigan AM 1000 W FT, only station in two-city metro of 14,000, only one other station in county of 50,000, w/building, land, \$235,000, terms considered. M St Cyr, 517-487-5986.

AM/FM combo fully automated, w/3 bdr studio combo on 3 acres of land avail, retiring, priced to sell. P Robillard, 318-624-0105.

FM in Southwest Texas, all new equip w/bldg & land, will sell part to investor. A Moll, KLXQ, 128 Memory Trail, San Antonio TX 78232. 512-496-0677.

Want to Buy

Looking for AM, FM or LPTV, problem stations, turnarounds, daytimers, dark, etc. OK, bdctr seeking new challenge, send complete details w/price & terms. J Powley, 1536 Logan, Altoona PA 16602. 814-944-8571.

Looking for AM, FM or LPTV, problem stations (turnarounds, daytimers, etc), broadcaster seeking new challenge, send complete details w/price & terms. J Powley, 1536 Logan, Altoona PA 16602. 814-944-8571.

AM stations: high power turnarounds at gd price, top 150 markets, daytimers & dark stations OK, include price/terms & city grade coverage map. Mr Stevens, POB 732, Langley SC 29834.

DISTRIBUTOR DIRECTORY

The following distributors serving the broadcast industry would be glad to help you with any of your requirements.

SPENCER Broadcast & Communications AUDIO-VIDEO-RF Where Service is #1 Now in our 10th year CALL 602-242-2211 FAX 843-2860

KIDD COMMUNICATIONS CALL US FOR... Audi-Cord Cart Machines & Audiopac Carts • Bogner TV Antennas • Cablewave Transmission Line • CRL Audio Processing • Eventide Digital Effects • Gentner Patch Bays • Jampro FM & TV Antennas • JBL Speakers • M/A Comm Video STL's • Mark Antennas • Orban Optimod's • Scala Antennas • Soundolier Equipment Racks • Studer-Revox Tape Recorders/Disc Players • Technics Turntables/Disc Players • TTC FM/TV Translators/Transmitters CALL US TODAY! KIDD COMMUNICATIONS 4096 Bridge Street • Suite 4 Fair Oaks CA 95628 916-961-KIDD(5433)

FCC's Engineering FM and TV Data Bases for your P.C. Call today to request a free sample. Communications Data Services 6105 E. Arlington Blvd. Falls Church VA 22044 (703) 534-0034

SANGAMO-ACUSHNET MICA CAPACITORS PLASTIC CORP.-NON-PCB OIL FILLED CAPACITORS RF-ANTENNA AMPETERS RCA-RAYTHEON-AEL TRANSMITTER PARTS TRANSFORMERS & CHOKES 250 WATT THRU 50 kW COMMERCIAL RADIO COMPANY BOX 43, CAVENDISH VT 05142 802-226-7582

THE SOURCE CALL US FOR ALL YOUR EQUIPMENT NEEDS Toll free: 800-223-8202 In Florida: 305-651-5752 ELECTREX COMPANY

CASSETTES - CARTS - REELS J & I AUDIO/VIDEO A wholesaler in the Radio and Television market. Now running SPECIALS on audio and video: BASF CASSETTES - AMPEX R-R's AUDIOPAK, FIDELIPAC & 3M CARTS For more information call person-to-person collect: Kris Elliot at 818-992-4288 or write to: J&I Audio/Video 20899 Kelvin Pl., Woodland Hills, CA 91367

CONSULTANTS

R.L. HOOVER

Consulting Telecommunications
Engineer

11704 Seven Locks Road
Potomac MD 20854
301-983-0054

Member AFCCE

R.J. GRANDMAISON, P.E.

CONSULTING ENGINEER
Applications and Rulemakings
11213 Split Rail Lane
Fairfax Station, VA 22039
(703) 764-0513
Member AFCCE

**RADIO SYSTEMS
ENGINEERING**

FCC Applications • Design
• Installation • Field Service

Experienced & Affordable

4289 Roanridge
Las Vegas, Nevada 89120

24 Hr: (702) 454-2085

**Contact
Radio World
Newspaper**
P.O. Box 1214
Falls Church, VA 22041
for availabilities.
Call
1-800-336-3045

**HARMON'S TOWER
SERVICE, INC.**

Maintenance Painting,
Antenna & Equipment
Installation,
Winch Services

453 B Broadway
Columbus, GA. 31901
(404) 327-1074

RF and Audio Coast to Coast

STEVE VANNI ASSOCIATES, INC.
BROADCAST TECHNICAL CONSULTANTS

Project Management
Facility Planning

P.O. Box 422 Auburn, NH 03032
(603)483-5365

**AUDIO CONCEPTS
& ENGINEERING**

Broadcast Audio

- Consultation
- Installation
- Optimization

P.O. Box 459
Mechanicsville, VA 23111
(804) 798-6633 (804) 356-8364
JEFFREY P. LOUGHRIDGE

**SPENCER
BROADCAST**

The Radio Station
Specialists

Chuck Spencer
Phoenix, AZ
602-242-2211

EVANS ASSOCIATES

Consulting Communications Engineers

FCC Applications, Design
& Field Engineering

Broadcast Engineering Software

216 N. Green Bay Rd.
Thiensville, WI 53092

(414) 242-6000

Member AFCCE

**W. LEE SIMMONS
& ASSOC., INC.**

**BROADCAST
TELECOMMUNICATIONS
CONSULTANTS**

5 Gracefield Road
Hilton Head Is., SC 29928
(803) 785-4445

SOFTWARE

FM CHANNEL SEARCH

FM Database pool
MSDOS
EGA Graphics-Color
Broadcast Technical
Consulting

Doug Vernier
Broadcast Consultant
1600 Picturesque Drive
Cedar Falls, IA 50613
319-266-7435

**DOWNEAST
ENGINEERING**

147 Durham Rd., Freeport, ME 04032

(207) 865-9002

Electronic Repairs & Services
Equipment Piled Up In Need of Repairs?
(Qualified Service Technicians)
New & Used Equipment (Call for
Price) New Studio Designs
BROADCAST SPECIALISTS
WILLIAM H. YANIK
(Manager, Sales and Service)

**Consulting Communications
Engineers**

- FCC Data Bases
- FCC Applications and Field
Engineering
- Frequency Searches and
Coordination
- AM-FM-CATV-ITFS-LPTV

OWL ENGINEERING, INC.
1306 W. County Road. F,
St. Paul, MN 55112
(612)631-1338 "Member AFCCE"

TOWER SERVICES

Light Replacement
Routine Maintenance
Ground Systems
Painting
20 years Experience

John Nix

PO Box 13244 Salem, OR 97309
503-581-4056
1-800-321-4056

MAGRILL ENGINEERING

(904) 591-3005

APPLICATIONS—CONSTRUCTION
UTILITY PROBLEMS SOLVED
FAIRFIELD, FLORIDA

SPECIALIZING IN ERECTION,
REPAIRING, PAINTING
AND MAINTENANCE
RADIO, TWO-WAY, TV, TOWERS
AND FLAG POLES

ASTEPELEJACK CO.

PAINTING AND STEEPLEJACK
CONTRACTORS

FULLY INSURED FOR YOUR PROTECTION
DON HIGHLEY 3722 ROMA
713-462-6105 HOUSTON, TEXAS 77080

**Moffet,
Larson &
Johnson, Inc.**

Consulting Telecommunications
Engineers

Two Skyline Place
5203 Leesburg Pike # 800
Falls Church VA 22041
703-824-5660
800-523-3117
Member AFCCE

**MIRKWOOD
ENGINEERING**

Rural & Remote Site
Field Engineering

50 Park Ave.
Claremont, NH 03743

603/542-6784

PARAMOUNT
COMMUNICATION SYSTEMS
INSTALLATION AND SERVICE OF BROADCAST
ANTENNA SYSTEMS/TOWER MAINTENANCE & ERECTION
WESTMONT, NJ (609) 869-0222

**Use The
ActionGram
For
Immediate
Action**

STATIONS . . . WTB

Looking for FM or AM/FM in Northwest Ohio,
Southeast Michigan, confidential serious re-
plies only. F Vobbe, Great Northern Bldg Co,
POB 5031, Lima OH 45802. FidoNet 1:234/16.

STEREO GENERATORS

Want to Sell

Moseley SCG-3T stereo gen, BO, KDKB, POB
6184, Kingman AZ 86402. 602-753-KDKB.

Moseley SCG-4T subcarrier gen, like new,
may be returned. J Kramden, WBRL, 3342
Perry, Marsellus NY 13215. 315-673-9049.

Motorola 1300/1310 C-Quam stereo system,
1360 kHz, CRL SPP 800, (2) SEP 400, SMP-
900, all gd cond, BO/whole package. J Dav-
is, WCHL, POB 2127, Chapel Hill NC 27514.
919-942-8765.

Want to Buy

Harris audio input control module for model
TE1 or TE3 FM exciter, RCA BTS-1A stereo gen,
low pass, pre-emphasis filters. C Gill, POB 371,
Indianapolis IN 46206. 317-923-2800.

SWITCHERS (VIDEO)

Want to Buy

Telemation/Bosch 1000 Series routing
switcher, 40x20 or larger, in operating cond
or as parts. T Steinke, POB 413, Milwaukee
WI 53201. 414-229-5470.

TAPES, CARTS & REELS

Want to Sell

Columbia Masterworks etc. classical pre-
recorded tapes (16), 7" reels, 75 pls, original
boxes, BO pls shpg, S Delahoyde, Box 33063,
Phoenix AZ 85067. 602-937-9088.

U-matic cassettes, like new, one pass only,
mostly 5 or 10 min lengths, cassettes include
library cases, some shipping cases, approx
350-500 avail, \$2 ea pls shpg. J Powley, 1536
Logan, Altoona PA 16602. 814-944-8571.

Background music on 10" reels, 375 ips, 1/2
trk mono, 1960 & 70's, min 6 hrs per tape, (12),
\$25 pls UPS. E Davison, 135 N Illinois,
Springfield IL 62702. 217-787-0800.

Records, 78 rpm, vintage MOR & Big Band,
also Classic 16" comm transcription discs,
BO. D Kelley, KISZ, POB 740, Cortez CO
81321. 303-565-1212.

**A&D
Cartridge Rebuilding
Service**

We clean, load & pack Serviced within 10
work days! Work guaranteed!
3380 Bakely Ave., Eau Claire, WI 54701
(715) 835-7347

Approx 100 10.5" NAB reels, oldies. J
McDonald. 303-669-3442.

Fidelipac 300 (34), vgc, 4, 5.5, 7.5 lengths, \$1
ea plus shpg. M Saady, First City Recd, 141-60
84 Rd 3E, Briarwood NY 11735. 718-846-2062.

Fidelipac NAB-300 carts, vgc, \$2 ea & (215
red) Master carts at 7.5 min long, \$2 ea/BO.
R Pastorik, WCMY, 216 W Lafayette, Ottawa
IL 61350. 815-434-6050.

U-Matic cassettes, like new, one pass only,
mostly 5 or 10 minute lengths, include library
cases, some shipping cases, approx 350-500
avail, \$2 ea pls shpg. J Powley, 1536 Logan,
Altoona PA 16602. 814-944-8571.

Audiopak A-2 (1270) music length, gd cond,
\$.75 ea. L Kolk, WSNX, 875 E Summit,
Muskegon MI 49444. 616-733-2126.

Over 3000 45's & LP's, all spanish in top
cond, will record for automation if needed. A
Moll, KLXQ, 128 Memory Trail, San Antonio
TX 78232. 512-496-0677.

Approx 300, 10.5" reels of tape w/AOR mu-
sic on them, 50°CT per reel plus shpg. S
Beeny, KRMS, POB 225, Osage Beach MO
65065. 314-348-2772.

20 year collection of 600 plus R-R tapes con-
taining jingles, airchecks, various prod, mu-
sic tracks, etc. Will sell w/dbx & Dolby NR
equip. BO. Send SASE for specific info. F
Vobbe, Great Northern Bldg Co, POB 5031,
Lima OH 45802. FidoNet 1:234/16.

Complete 78 rpm library, not picked over, as
it was left 30 yrs ago over 1,260 records & AS-
CAP/BMI books from 1949-1972, many fa-
mous names & songs, must buy entire col-
lection. BO. G Johnson, WAGN, 413 10th,
Menominee MI 49858. 906-863-5551.

Want to Buy

LP records, Easy Listening mostly & others,
hopefully a station changing over to CD can
fulfill our need. Buck, KBUX, POB 1, Quartz-
site AZ 85346. 602-927-5111.

ET's 16" Thesaurus Here's to Velericus guest
star, orig or top quality tape copies & library
catalogs. C Fuller, Voices, POB 153, La
Grange IL 60525. 312-579-9578.

Used tapes & reels for automation, 10" reels.
A Moll, KLXQ, 128 Memory Trail, San Anto-
nio TX 78232. 512-496-0677.

CD Radio Shows, K.B.F.H., Ticket to Ride,
Close Up... & other CD rarities. Call 414-744-
4785, Steve Johnson, 3126 S New York Ave,
Milwaukee WI 53207.

TAX DEDUCT EQUIP

Comm College has CP for new stereo FM,
need: 3 kW xmr, antenna, iso-coupler, mod
mon, compressor limiter, RT machines, TC
machines, TT's. J Gaboury, Arizona Western
College, 602-344-7695.

Non-profit missionary station in El Salvador
needs 8008's in any cond so long as the
bases, pins & plate caps are gd, will pay ship-
ping; Also need 892R's for xmr, will pay ship-
ping. J Coulter, YSL, 5484 San Patricio Dr,
Santa Barbara CA 93111. 805-967-6410.

Bdct Eng student at New England School
of Bdctg in Bangor ME seeks any & all old
bdctg equip in working cond or in need or mi-
nor repair, will pay shipping & will send tax
receipt. S Brough, POB 159, Skowhegan ME
04976. 207-474-9068 or 5171 (work evs).

Non-profit university seeks used AV prod
equip, primarily cart/cass machines, audio
processing gear & portable video equip. G
Curtisinger, Univ of Detroit, 3800 Puritan,
Detroit MI 48238. 313-927-1173.

Any type of video equipment, working or
not for local chapter of Red Cross video train-
ing studio, will pay shipping & provide tax
deduction certificate. G Kirby, 13613 US 36,
Marysville OH 43040. 513-644-0468.

Used radio equip for donation to college sta-
tion. P Hess, WPPJ, 201 Wood, Pgh PA
15222. 412-392-4725.

Radio reading service for the blind & print-
handicapped in CT looking for donation of 2
cart machines for Fairfield county satellite stu-
dio, will pay for shipping or pick-up. Cynthia
Clark, CRIS Radio, 589 Jordan Ln, Wethers-
field CT 06109. 203-246-3579.

Electronics eng student seeks donation or
old but repairable, studio or xmrtrg equip. RS
Lynn, Rt 1 Box 152-D, Loudon TN 37774.

Group home working w/troubled teenagers
seeking donated video & audio or related equip
for tax purposes. R Scott, ISOT Inc, Box 35,
Canby CA 96015. 916-233-4106 or 233-5151.

HF/VHF/UHF amateur and/or commercial
comm equip in working or repairable cond,
transceivers or handhelds, packet TNC & PC
equip; 12V battery back-up, will pay shipping
or pick-up; CB equip also. J Bondon, 7101 W
80th, Los Angeles CA 90045. 213-642-3698.

Eng student desiring donation of old bdct
equip (anything) in repairable cond, will pay
all shipping charges, EE student at Purdue.
C Gill, POB 371, Indianapolis IN 46206. 317-
923-2800.

TEST EQUIPMENT

Want to Sell

Houston Instruments DMP29 8-phen plotter,
A/B size, DM/PL language compatible
w/everything from 1-2-3 to AutoCAD, never
used. \$800. J Kreines, 5330 Kennedy, Mill-
brook AL 36054. 205-285-6179.

Interstate Electronics F-34 rack mount/desk
mt 3 MHz function gen; Fidelipac w/w & flut-
ter meter; Harris stereo gain set; Heathkit SM-
128B factory wired freq counter; Bird Thru-
line & 43 slugs, 4275 sampler, 8060 25 & 50
W dry loads, BO. B Royster, KQMB, 1019 Cor-
dova, San Diego CA 92107. 619-223-3413.

RCA MI 11350 B1-11A transmission measuring
set, made by Daven, precision attenuators over
100DB in 0.1 dB steps, input & output Z wide
range, meter calibration changes automatic-
ally w/output Z, requires external audio source,
\$250. R Cone, FM Unlimited, 6731 N Hermitage,
Chicago IL 60626. 312-743-5850.

Delta 01B-3, almost new in-line bridge & RG-
3, \$4000. J Battison, 2684 Slatte Rte 60, Lon-
donville OH 44842. 419-994-3849.

Leader LSG-231 FM stereo signal & gener-
ator, brand new, \$400. D Agnew, KKNB, 5601
S 27th, Lincoln NE 68512. 402-421-2223.

General Radio 1606A impedance bridge, ex-
cel cond w/fittings & manual, \$800/firm. F
Shields, KEVR, POB 2187, Kerville TX 78028.
512-895-1230.

HP AN/USM-37A microwave test set w/stand-
ing wave ind. 415B, slotted lines 806B, H810B,
X810B, 809 carriage, waveguides & metal
case, \$500; Narda 25223 microwave coupler
directional, 1.7-4.2 GHz, \$100. J Cunningham,
KHCC, Rt 2 Box 113B, Stonewall OK 74871.
405-265-4496.

3M 210 SG/CB signal/color bar generator, BO,
R Rhodes, POB 1550, NUNY 10101. 212-245-
5045.

Delta 01B-3 & RG-3, gd cond, \$4000/BO. J
Battison, 2684 State Rte 60, Loudonville OH
44842. 419-994-3849.

RCA WF48A AM freq meter, 1070 kHz, gd
cond, BO; Nems Clarke 108E phase monitor,
fair cond, BO; RCA WA7-44A audio oscilla-
tor, fair cond, BO; military surplus audio osc-
illator, fair cond, BO. J Keller, WKOK, POB
1070, Sunbury PA 17801. 717-286-5838.

Tek 1L20 spectrum analyzer, 10 MHz-4.2 Gmz;
Tek 547 oscilloscope, BO. C Springer, KSEC,
POB 890, Lamar CO 81052. 719-336-2206.

TEST EQUIPMENT

We Buy and Sell

All types of late model Test Equipment
Hewlett-Packard, Tektronix, Wavetek,
Fluke R.F. & Microwave a Specialty

G.V. BELL & ASSOCIATES
San Mateo, California
1-800-366-5240
(Inside 408/415 area)
415-366-5240
FAX 415-369-9698

Harris/Gates 994-7023-001 stereo gain test
set, line or mike level out, allows stereo proofs
w/only one initial set-up, i, r, mono, L+R, L-R,
noise, \$300/BO. S Daitch, PSC 1 Box 362,
APO San Francisco 96286.

Tek FG504 function generator, 0.001 Hz to 40
MHz, amplitude or freq modulated, log or lin-
ear sweep, phase-lock mode, mint cond, BO.
K Andrysiak, 1128 E Victoria, S Bend IN
46614. 219-287-3267.

B&K 1260 rack mount video pattern/sync gen,
like new cond, \$1100/BO. B Hoover, Colorburst
Comm, Box 39, Valier PA 15780. 814-938-7237.

RCA WX2D 3002-D field intensity meter,
\$500. Chuck, 919-623-9966.

Old test equip to sell or trade, includes
Heathkit oscilloscope, color bar gen, resis-
tance sub box, condenser sub box, iso trans,
grid dip, ant imp, EICO multi tracer, Senco
transistor checker, genometer, Sprague tel-
o-mike, EICO 950, Cornell Dubilier, Jackson
TVG-2, military signal generator & more, al-
so alot of tubes. R Scott, Box 35, Canby CA
96015. 916-233-4106 or 233-5151.

Heath scope IOW-12, gd cond w/book,
\$60/BO; EICO 221 VTVM, gd cond w/book,
\$25/BO. D Carver, KZBK, 107 S Main, Brook-
field MO 64628. 816-258-7458.

Bird 8745-677 20 kW water cooled dummy
load w/3-1/8 EIA flange, \$995. G Liebisch,
WPTF. 919-876-0674.

Several pieces of equip from estate of the
late T A Giles/PE. R Giles, 6189 Hwy 62, Ge-
orgetown IN 47122. 812-944-6786.

B&W 200 audio oscillator; B&W 400 distor-
tion meter. Adolph, 915-949-2112.

Score VA-62, NT64, CV63, PR-57, all like
new, \$2500. L Clinton, KARN, POB 4189, Lit-
tle Rock AR 72214. 501-661-7500.

Potomac Instruments AG-51, excel cond,
\$1000. P Lancaster, Howard Schwartz Recd,
420 Lexington, Ste 1934, NUNY 10170. 212-
687-4180.

Want to Buy

B&W H10 dist meter and/or Gates gain set,
will pay up to \$150 for ea in gd clean operat-
ing cond. J Alexander, 1511 N Jackson, Rus-
sellville AR 72801. 501-968-7270.

Need to find the whereabouts of Manke In-
struments Co, originally in Fresno CA, made
M-1 wow & flutter meter. E Davison, Multiplx
Background Music, 135 N Illinois, Springfield
IL 62702. 217-787-0800.

MARATHON PRODUCTS COMPANY

Audio Cartridge Rebuilding Division

Rebuilding/reloading, like new, all brands, any length,
\$1.50 ea. FOB our plant, 48 hrs delivery.

New NAB Marathon cartridges prices on request.

35 Years professional experience!

Lifetime member AES R.D.MYERS Sr.

Manufacturers of Audio Devices, Continuous Tape Mag.

69 Sandersdale Rd.,
Charlton, MA 01507

1-508-248-3157 or 1-508-853-0988

**DISPLAY YOUR CONSULTANT'S CARD HERE
AND BE SEEN BY OVER 21,000 READERS**

Call Simone Leser at 800-336-3045

EMPLOYMENT

To place ads in this section, use the ActionGram form. To respond to box numbers, write Radio World, PO Box 1214, Falls Church, VA 22041, Attn: _____

HELP WANTED

Dallas news & sports station is looking for Assistant Chief Engineer. Applicant should be aggressive w/strong studio & transmitter maintenance background. SBE cert a plus. Write to: Chief Engineer, KRDL Radio, 1080 Metromeda Pl, Dallas TX 75247.

Shadow Traffic Network's New York network center needs a second engineer. Duties include repair & maintenance of audio, RF, computer & telecommunications equip. Applicant must be familiar w/needs of a broadcast operation. Reply to: Jim Walling, Shadow Traffic network, 201 Route 17, Rutherford NJ 07070.

VA Broadcast Combo seeks Chief Engineer. Experience necessary. Excellent environment, good benefits. Resume & requirements to Broadcast Technical Advisors, POB 1713, Yorktown VA 23692. EOE.

Engineering Manager, KXOA AM/FM, Sacramento, seeking an individual w/a good mix of technical, business, & people skills to lead engineering department. Must have good communication, computer, & troubleshooting skills; also experience w/AM DA, FM, & automation systems. Send resumes & letters of interest to: John Geary, General Manager, KXOA, 280 Commerce Cir., Sacramento CA 95815. EOE, M/F.

Chief Engineer for Richmond Country FM w/all new studio & RF facility. Position includes company benefits & market competitive salary. Additional part-time work available. Reply with resume to B. Paul Moore, VP/FM, WKHK(FM), 300 Arboretum Pl, Ste 590, Richmond VA 23236.

Small/Medium Mkt GM/Station mgr avail, credible ref, prof, former owner, preferably Southeast but all offers considered. Orlando Bank, Box 2031, Sylva GA 30467. 912-564-2922 before 11AM or aft 10PM Eastern.

Engineering/programming or entry sales position wanted in SF Bay area, also interested in rep position for broadcast equipment. B Berman, 174 Morningsun, Mill Valley CA 94941. 415-388-8368.

Announcing or engineering position wanted for 28 yr old. Mark, 304-525-3981.

Experienced newsman would like position in Texas, tape & resume upon request. Inquiries to: Radio World, POB 1214, Falls Church VA 22041. Attn: Box 89-09-01RW.

Engineer, FT, RF, video, audio, solar, FCC genrl, SBE cert, ham, educ or com'l, Sunbelt, Chicago, manu. sales. Frank, 312-890-9246.

Commercial writer & salesman w/unique approach will grab accounts for you, Orlando area, radio only. R Harvey, Apt 1126, 4200 Center Key Rd, Winter Pk FL 32792. 407-678-4591.

Innovative veteran NYC talk-radio producer seeking greener pastures in Top 12 markets: Radio/TV. J Segal, 212-966-0186.

CE Natl Black Network, former CE NJ state college radio station, NARTE, NABER, FCC commercial license w/radar, PT, FT, contract work. M Rakoff, 114-41 Queens Blvd Ste 148, Forest Hills NY 11375. 718-591-3859.

Engineer, 20 yrs exper including AM directional, high power FM, station construction, seeks position in Northeast or Upper Midwest, but all locations considered. Reply to: Radio World, POB 1214, Falls Church VA 22041. ATTN: Box 89-10-01RW.

Sharp, young, aggressive audio sales pro seeks position as marketing mgr for respected, stable pro audio mfr. Bill, 415-726-4786.

Newcomer wanting entry level radio, 10 mos station work in tech, traffic & mgmt, will start from bottom. D Rayner, 503 Sunnyside, Aurora IN 47001. 812-926-2013.

Wish to relocate to Charlotte NC. 13 yrs in radio, air, production, traffic, detail-oriented pro, on- or off-air position considered. Jim, 813-461-3192.

Bdct vet w/15 yrs exper will soon be leaving nationally syndicated company, desires GM/GSM position in North Carolina or eastern area. John, 1-800-527-2514 X520.

Engineer w/20 yrs exper in AM radio, FCC license, looking for night, week-end board shift, prefer south, mid-west or southern California. Reply to: Radio World, POB 1214, Falls Church VA 22041. ATTN: 89-10-02RW.

Quality entertainer w/33 yrs exper, marketable, specialize in Big Bands, oldies, 7-midnight or all night. J English, 2450 Pine Island, Matlacha FL 33909. 813-283-3910.

Eng/announcer, w/over 18 yrs in radio, 13 yrs as chief & PT adv salesman, seeking gd FT position, dedicated & team player, FCC, SBE, NARTE, desire SE US, East or West Coasts. E Garrett, 5857 Sheldon Ct C, College Park GA 30349. 404-766-0742/2577.

TV/Radio thoroughbred, dynamic, intelligent, creative, charismatic GM, earned mgmt from talent/sales successes, incredible motivator, team player, can & will do it all. A Stephens, 8101 S US Hwy One Ste 7C, Jupiter FL 33477. 407-743-1458.

Broadcast eng w/hrs of exper as CE & consultant, excel track record of tech achievements & effective teamwork. Write: Radio World, POB 1214, Falls Church VA 22041. Attn: Box 89-11-01RW.

Personality desires fun, promotionally active situation w/creative freedom, AM or FM, night or day shift, Eleven year pro, in AZ now. Call Mike, 802-721-7263.

Electronic comm eng w/11 yrs exper, fluent in French/German, FCC license, computer skills avail, overseas preferred, will relocate. C Martin, POB 9781, Bowling Green KY 42103.

POSITIONS WANTED

Air personality, 8 yrs exper, seeks PT fill-in on-air work in Los Angeles market. T Greene, 215-224-4651.

Technical Director
Senior position in charge of Technical Operations and R&D at Acoustiguide Corporation, international market leader providing audio interpretation to museums and historic sites. Responsibilities cover managing all technical operations in the U.S. and overseas including R&D, project feasibility, budget preparation, personnel management and field technical support. Requirements include audio and RF background with a minimum 5 years technical experience; good verbal communications skills; technical sales engineering experience useful. Send resume to:

Ms. Eaton
Acoustiguide Corporation
177 East 87th Street
New York, NY 10128

AUDIO SALES MANAGER RADIO BROADCAST EQUIPMENT

Outstanding opportunity to assume full responsibility for merchandising and marketing cartridge machine and audio console product line in the U.S. and Canada. This position reports to the Manager, Domestic Sales. Product distribution is primarily through distributor/dealer organization.

Successful candidate must have good communication skills with technical knowledge of broadcast systems and technology. Broadcast manufacturer or distributor sales exper. required. Ability to develop and execute program to increase sales and market share is essential.

Salary commensurate w/exper., education and abilities. Exceptional benefit package includes group insurance, profit sharing and 401 (k) Plan. Please send resume to Steve Wall, Director of Personnel or call collect.

BE BROADCAST ELECTRONICS, INC.
P.O. BOX 3606 Quincy, IL 62305
217-224-9600

Engineering

We're changing the way people communicate

At AT&E Corporation, we're going to be changing the way people communicate with each other because of our new RECEPTOR System. Our revolutionary wristwatch allows people on the move or away from a telephone to stay in touch, or communicate with people across the world.

Our Portland, Oregon facility offers clean water and air, affordable housing, no sales tax and an easy commute, so if these advantages appeal to you, check out the following options:

Project Leader— FM Subcarrier Operations

This position will be responsible for engineering communications systems to/from transmitter sites, installation and maintenance of equipment, FM transmitter testing, and coverage area testing. The successful candidate will have a minimum of two years' experience in engineering and operating FM subcarrier systems. Knowledge of telephony and data communications is a plus. This Project Leader position has strong potential for management growth.

We provide an excellent salary and a very generous benefits package. If you'd like to change the world, please send your resume, salary history and references to **Manager of Corporate Staffing**:

AT&E

AT&E Corporation
10450 SW Nimbus Ave.
Portland, OR 97223
EOE

Equal Opportunity Employer

EMPLOYMENT SECTION

HELP WANTED: Any company or station can run "Help Wanted" ads at the flat rate of \$25 per listing per month (25 words max). Payment must accompany insert; **there will be no invoicing**. Blind box numbers will be provided at an extra charge of \$2. Responses will be forwarded to listee, unopened, upon receipt. Call 800-336-3045 for display rates.

POSITIONS WANTED: Any individual can run a "Position Wanted" ad, FREE of charge (25 words max), and it will appear in the following 3 issues of Radio World. Contact information will be provided, but if a box number is required, there is a \$2 fee which must be paid with the listing (**there will be no invoicing**). Responses will be forwarded to the listee, unopened.

Mail To: BROADCAST EQUIPMENT EXCHANGE, PO Box 1214, Falls Church, VA 22041

Broadcast Engineer

WRKO-AM/WROR-FM in Boston has an immed. opening for an exper. engineer for studio maintenance, remote setup/operation, some xmt work on 50kW AM & 10kW FM plants. Extensive, state-of-the-art facilities in Top 10 market. Applicants must have FCC license & be willing to work some evenings & weekends. Send resumes to: Karen Hackett, WRKO/WROR, 3 Fenway Plaza, Boston, MA 02215. An equal opportunity employer, M/F/H/V.

TRANSMITTERS

Want to Sell

NM-PA4A pwr amp w/(2) 4CX250B 32 MHz plug in, mostly tubes, cond unknown, looks fair & complete w/all pwr supplies in same 19" rack mount, you pick-up/ship. 65 lbs, \$160/BO. H Jeschke, 5820 Overbrook, Philadelphia PA 19131. 215-477-5302.

RCA 50 kW AM (2), spare tubes & parts. O Borgen, WMIN, POB 25130, St Paul MN 55125. 612-739-4433.

Gates 250-GY 250 W AM on 740 kHz, working order, needs to be retubed & cleaned, \$500/BO pls shpg; Collins 20V2 1 kW AM for parts only, BO. D Kelley, KISZ, POB 740, Cor tez CO 81321. 303-565-1212.

Home built carrier current AM 25 W carrier current tube type, set to your freq, complete w/instructions, \$400. J Cunningham, KHKC, Rt 2 Box 113B, Stonewall OK 74871.

Trade RCA 20 kW for Harris or Collins 1-10 kW xmt. J Mauk, KMJ, POB 70002, Fresno CA 93744. 209-266-5800.

30 W digital FM exciter, field selectable, 1/2 price. J Phillips, WZOM, 408-1/2 Clinton, Defiance OH 43512. 419-784-1059.

McMartin BF25K-FM, 1978 25 kW w/Harris MS 15 exciter, complete spare HV PS & parts from stripped 2nd unit, in service, avail Sept-Oct, \$32,000. D Solinske, WWRM, POB 22000, St Petersburg FL 33702. 813-576-1073.

Gates BC-10H 10 kW/5 kW AM in excel cond, \$15,000. Jim or Richard, 801-637-0863 or 1752 or 3028.

McMartin BF25K 27.5 kW grounded grid, no PCBs, spare HVPS, circuit boards, transformers, in service, \$30,000. D Solinske, WWRM, POB 22000, St Petersburg FL 33702. 813-576-1073.



ARMSTRONG TRANSMITTER

TUNED, TESTED, WARRANTED

We are the leading remanufacturer of radio transmitters with customers worldwide.

Our transmitters are:

- * Remanufactured to factory specs.
 - * Tuned to your frequency
 - * Guaranteed
 - * 48 hours burn-in prior to shipping
- See before you buy, visit our showroom

Why spend a fortune on a new one?



ARMSTRONG TRANSMITTER
5046 Smoral Road (315) 488-1269
Syracuse, NY FAX (315) 488-1365



ARMSTRONG TRANSMITTER

TUBES AT

DISCOUNT PRICES

NEW TUBES FOR LESS AND REBUILT TUBES FOR LESSER!

- * Major brand REBUILT TUBES for less than the rebuilders charge!
 - * FREE SHIPPING ON ALL REBUILT TUBES!
 - * NEW Major Brand TUBES at DEEP DISCOUNTS!
 - * Full manufacturers WARRANTY PLUS
- ARMSTRONG'S absolute SATISFACTION GUARANTEE**
- * CALL TOOTIE in our TUBE department FOR A QUOTE on ANY TUBE TODAY!



You'll Love Tootie's Tubes!
ARMSTRONG TRANSMITTER
5046 Smoral Road (315) 488-1269
Syracuse, NY FAX (315) 488-1365



**30kW UHF-TV
RCA TTU-30C
Tunes Channel 30-51
Just off the air!**

ARMSTRONG TRANSMITTERS
5046 Smoral Road (315) 488-1269
Syracuse, NY FAX (315) 488-1365
Open 7 days

TRANSMITTERS . . . WTS

Gates BC-1F 1 kW AM, excel cond, \$2000. J Kramden, WBRL, 3342 Perry Rd, Marselis NY 13215. 315-673-9049.

RCA BTE-10C/BTS-1A exciter, stereo gen, metering panel & CBS stereo Volumax in 4 rack w/spares, complete 10 W xmt, will sell separately, \$700 pls shpg. T O'Laughlin, O's Own Labs, Rt 1 Box 41, Barneveld WI 53507. 608-924-2001.

Collins 21E 5 kW AM, gd world cond, original owner, \$5000. C Webster, WGVM, 1383 Pickett, Greenville MS 38701. 601-334-4559.

FM ANTENNAS

1 BAY	\$1,000
2 BAY	2,000
3 BAY	2,900
4 BAY	3,800

MORE BAYS AVAILABLE
All warranted, tuned and tested

ARMSTRONG TRANSMITTERS
5046 Smoral Road (315) 488-1269
Syracuse, NY FAX (315) 488-1365
Open 7 days

Ron Radio Comm, Inc.
P.O. Box 201
Brightwaters, NY 11718

Energy Onix FM Transmitters

- Low Power- 100 - 1000 Watt Solid State
Broadband NO-TUNING REQUIRED
- Medium Power 1.5kw to 12kw Single Tube
Proven Grounded Grid Design
Including the MK-7.5
The only transmitter made for the Class A power increase.
- High Power 15kw, 22kw, 25kw, 30kw & 40kw
2 Tube Proven Grounded Grid Design
Before you spend TOO MUCH on Bernie Wise's OLD DESIGN call us!
800-666-3525
516-665-6482fax

Up To \$500 REWARD

For information leading to the purchase of used AM/FM Transmitters

- \$500 for most 20-30kW FM
- \$250 for late model FM's 5-20kW
- \$100 for any FM over 1kW & any AM newer than 1975

ARMSTRONG TRANSMITTERS
5046 Smoral Road (315) 488-1269
Syracuse, NY FAX (315) 488-1365
Open 7 days

Jones-Tepco J-317 FM translator, 10 W, \$1400; antennas also available. D Silver, KNKK, Layton Hills Mall, Layton UT 84041. 801-973-7759.

ITA FM-250B w/RCA exciter, all working when removed, \$1000. D Parsons, KLUH, POB 1313, Poplar Bluff MO 63901. 314-686-1663.

RCA BTF 20E1, to trade for Harris or Collins 1-10 kW FM xmt. J Mauk, KMJ, POB 70002, Fresno CA 93744. 209-266-5800.

Harris plate transformer for MW 5A, new, in crate, \$1000/BO. J Long, 4452 Koblan Ct, Hixson TN 37343. 615-877-9000.

**Dummy Loads
RF Plumbing
RF Cable
FM Antennas**

ARMSTRONG TRANSMITTERS
5046 Smoral Road (315) 488-1269
Syracuse, NY FAX (315) 488-1365
Open 7 days

**LEASING AVAILABLE
ON USED
TRANSMITTERS**

**AMERICAN BROADCAST
FINANCIAL CORPORATION**
414-482-2638

**Pomar Electronics
WANTS USED
TRANSMITTERS
&
EQUIPMENT**

For the best deals call

Oscar Pomar
1615 STA. MARIA AVE.
LAREDO, TEXAS 78040
(512) 722-9437
FAX: 512-722-1795

TUBES
(while supplies last)
This month's special
5762 New rebuilds & Used Tested
\$595 ea \$110ea

ARMSTRONG TRANSMITTERS
5046 Smoral Road (315) 488-1269
Syracuse, NY FAX (315) 488-1365
Open 7 days

RCA 250M excel cond, less than 500 hrs, full power, clean, you pick up, BO. LJ Maierhofer, WTGC, 101 Armory, Lewisburg PA 17837. 717-523-3271.

Johnson Viking I 100 W shortwave xmt r vfo ham bands 80-10m, AM, \$75. J Feasel, 13549 Morse, Pataskala OH 43062.

Nautil AMPFET 10 AM solid state, 1510 kHz, 2.5 yrs old, excel cond, includes spares, etc, towers, ATU's, (4) tower phasor, will negotiate. B Williamson, WALL, One Bdct Pl, Middletown NY 10940. 914-343-7400.

**DON'T BUY USED!
WITH PRICES LIKE THESE:**

- FM OPTIMODS 8100 A/1 \$3995!
- FM EXCITERS STARTING AT \$2349!
- REVQX PR-99 MKII \$1762!
- TASCAM 112 CASSETTE \$466!
- TASCAM 122 MKII CASSETTE \$749!
- TECHNICS SL-P555 CD \$308!
- SHURE SM-7 MICROPHONE \$328!
- COAX CABLE-3 INCH \$16.75 FT
- COAX CABLE-1 5/8 INCH \$8.96 FT
- NEW - MOD-MINDER \$1899!
- AUDIOPAK CARTS CALL!
- SCOTCHCARTS CALL!
- CART MACH. & CONSOLES CALL!
- PLUS - BEs NEW FX-50 WOW!
- CRL, BE, ERI, QEI, SHIVELY & MORE

**FACTORY NEW & FULL WARRANTY
PLUS MANY USED TRANSMITTERS**

RFS 816-635-5959

BEXT Inc.



**High performance
at affordable prices.**

- New front panel programmable composite STL's.
- New directly programmable FM composite receivers
- New options for synchronous boosters and translators
- New FM power levels: 2, 10, 20, 30, 80, 100, 200, 250, 500, 800, 1000, 1500, 1800, 2000, 3000, 3500, and 15000 W

Bext, Inc.
739 Fifth Avenue.
San Diego, CA 92101
619-239-8462
Telex 229882 Fax 619-239-8474

AM TRANSMITTERS

1kW ITA 1000
1kW Gates BC-1F
1kW McMartin BA-1K
1kW Harris BC-1G
5kW RCA BTA-5T
5kW Collins 21-E
5kW Gates BC-5B
5kW Gates BC-5E
50kW Continental 317C
-Many others-

ARMSTRONG TRANSMITTERS
5046 Smoral Road (315) 488-1269
Syracuse, NY FAX (315) 488-1365
Open 7 days

INR Tech Mdl 1000 drive-buy radio transmitter, synthesized FM xmt r advertising message, uses standard endless cassette tape for message, new in box, \$425/BO. M Peterson, 3810 Lancaster Ste 6, Plymouth MN 55441. 612-544-6391.

McMartin BF25K-FM, 1979 27.5 kW w/low pwr cut back, grounded grid, spare HVPS & boards, panels, iron from stripped second unit, \$30,000. D Solinske, WWRM, POB 22000, St Petersburg FL 33742. 813-576-1073.

FM TRANSMITTERS

1 kW RCA-BTF-1
1 kW Collins 830
2.5 kW Harris
2.5 kW Collins 831-D2
10 kW Harris 10H3
20 kW Collins 831-G-1

PMA Marketing
414-482-2638

Harris MW1, 500 W D 1520 Hz, like new, BO. HS Kilgore, KMPG, POB 1507, Hollister CA 95023. 408-637-7476.

Collins 21-E 5 kW AM's (4), Gates BC-5E (3), RCA BTA-5T (1) Choice \$8700. 1 kW AM's, Gates BC-1G (2), Gates BC-1F (3), Gates BC-1J (2), Collins 20V3 (2), McMartin BA-1K (2), \$2000-\$5500. Jarry Kautz, Armstrong Transmitter. 315-488-1269.

FM TRANSMITTERS

1kW Gates FM-1B
1.5kW McMartin BF-1K
3kW CSI 1000 (1986)
3kW Singer 3.5kW
5kW Gates FM-5B
5kW CCA 5000D
5kW RCA BTF-5D
10kW RCA BTF-10B
10kW RCA BTF-10C
10kW RCA BTF-10D
10kW Collins 830F
20kW RCA BTF-20-E-1
20kW Harris FM 20-K
27.5kW McMartin BF-25K
30kW Broadcast Electronics 30kW

ARMSTRONG TRANSMITTERS
5046 Smoral Road (315) 488-1269
Syracuse, NY FAX (315) 488-1365
Open 7 days

Want to Buy

UHF & VHF TV translators, 10-100 W, will consider old UHF band 70-83 equip. J Powley, 1536 Logan, Altoona PA 16602. 814-944-8571.

RCA BTE 10-C crystal ovens; Gates BC1F AM xmt r; Raytheon RA1000, parts & info; Gates 25-A AM info. C Gill, POB 371, Indianapolis IN 46206. 317-923-2800.

RCA BTE 15A FM exciter w/stereo & SCA generator. WJON, POB 220, St Cloud MN 56302. 612-251-4422.

Low band 2-6 VHF TV xmt r, 100 W to 11 kW, exper eng can handle removal; RCA TTU-1B or TTU-2A UHF TV xmt r for parts. J Powley, 1536 Logan, Altoona PA 16602. 814-944-8571.

Low band (2-6) VHF TV, 100 W to 11 kW; RCA TTU-1B or TTU-2A UHF TV for parts. J Powley, 1536 Logan, Altoona PA 16602. 814-944-8571.

Any 1kW amp, xmt r, translator for channel 61. S Kappa, 402-476-6115, Fax: 402-476-6000.

UHF & VHF TV translators, 10 to 100 W, will consider old UHF band (70-83) equip. J Powley, 1536 Logan, Altoona PA 16602. 814-944-8571.

Dummy load for 20,000 W FM xmt r, used in gd cond. Kurt, KTRZ, Box 808, Riverton WY 82501. 307-856-2922.

Any 10,000-20,000 W, fixable w/manuals, any age, w/filters & tunable to 101.5 MHz. M McVey, 620 Lake Rd, Ottamwa IA 52501. 515-682-0498.

TTC XL10FM 10 W FM translator. J Mache, KRBS, POB 5180, Roseburg OR 97470. 503-672-6641.

Parts for RCA TT10AH/TT25BH as well as 5762 & 6166A tubes. J Paciorowski, The Imes Group, 603-641-9060.

AM xmt r w/2-2.5Kw, prefer single stage power needs; also a used 3K FM. Write WRDN Box 208 Durand WI 54736. 715-672-8989.

Late model FM 1000 W stereo w/exciter or without, late model exciter. LJ Maierhofer, WTGC, 101 Armory, Lewisburg PA 17837. 717-523-3271.

Crystal for 640kHz for Gates 1-T xmt r. M Rice, WBOW, 1301 Ohio, terre Haute IN 47807. 314-947-0600.

TUBES

Want to Sell

Tek CRT's for 528, 528A, & 1420 video monitors. A Weiner, Britton Rd, Monticello ME 04760. 207-538-9538.

Tubes, transmitting, semiconductors, diodes, rectifiers, transistors, int. circuits, connectors, wire & cable. Eimac, Amperex, RCA/Burle, Motorola, Intel, Thor Electronics, Call 800-666-THOR (8467).

3CX1500A7, 4CX5000A, 6146B, 4CX2508, 4CX3000A & more. We carry large inventory all major brands, Eimac, Amperex, RCA, etc. Call Stew 1-800-842-1489.

**ELECTRON
TUBES**

**Partial List: 6623, 23791,
TH150, 6425F, 5604,
6696, 6697, 5681,
5682, 5671,
7804, 3CX10,
000H3, 3CX20, 000H3,
4CS5000A, 4CX35, 000C**

**Vacuum Tube
Industries, Inc.**

**1-800-528-5014
508-584-4500**

**REBUILT
ELECTRON TUBES**

**Partial List: 6623, 23791,
TH150, 6425F, 5604,
6696, 6697, 5681,
5682, 5671,
7804, 3CX10,
000H3, 3CX20, 000H3,
4CS5000A, 4CX35, 000C**

**Vacuum Tube
Industries, Inc.**

**1-800-528-5014
508-584-4500**

TUBE REBUILDING

**FREELAND
PRODUCTS**

Since 1940
SAVE ABOUT 50%
—We buy dud tubes—

800-624-7626
504-893-1243
FAX 504-892-7323

**FM BROADCASTERS!!
We can meet all your
FM transmitter needs!!**

SOLID STATE - LOW POWER
Amplifiers and transmitters are available at the popular levels of 30W, 100W, 300W, 500W, and 1KW. All units are solid state, broadband, and designed for both local and remote operation.

ONE AND TWO TUBE HIGH POWER
Medium transmitters with broadband solid state drivers and one zero bias grounded grid triode in their PA are available at 1.5KW, 3.5KW, 5.5KW, 7.5KW, and 12KW. Higher power transmitter utilizing two grounded grid triodes (one as a driver) are available at standard outputs of 15KW, 22KW, 25KW, 30KW, 40KW, and 50KW.

Energy-Onix

752 Warren Street Hudson, New York 12534
(518) 828-1690 FAX (518) 828-8476
A Wise Enterprise

TRANSCOM CORP.

Fine Used AM & FM Transmitters
and Also New Equipment

For the best deals on Celwave products,
Andrew cable,
Shively & Comark antennas.

1980 CCA 28,500 FM
1980 Harris FM 20 K
1976 RCA BTF 20E1
1976 Harris MW5A
1980 Harris MW50A
1976 CCA AM 50,000D, 50 kW AM
1985 CSI T-3-F

201 Old York Rd.
York Plaza Ste 207
Jenkintown PA 19046
215-884-0888

Telex No. 910-240-3856 (TRANSCOM CORP. UQ)
FAX No. 215-884-0738

TUBES . . . WTB

Want to Buy

RCA 6181, used as final in RCA TTU-1B UHF TV xmr. J Powley, 1536 Logan, Altoona PA 16602. 814-944-8571.

RCA 8021 xmtg tube, any cond, used in old RCA TT-5 xmr. A Weiner, Britton Rd, Monticello ME 04760. 207-538-9538.

We buy electron tubes.

Contact us if you have any for sale.

PATH

507 Superior Ave. Newport Beach CA 92663 714-722-6733

Surplus electron tubes, all kinds, all quantities, sockets, plate caps, etc. C Dripps, Kurluff Ent, POB 2204, Irwindale CA 91706. 818-444-7079.

RCA 6181, used as final in RCA TTU-1B UHF TV xmr. J Powley, 1536 Logan, Altoona PA 16602. 814-944-8571.

Tubes for Marti xmr, 6252 tube (4). LJ Maierhofer, WTGC, 101 Armory, Lewisburg PA 17837. 717-523-3271.

4CX3500-A needed. A Moll, KLXQ, 128 Memory Trail, San Antonio TX 78232. 512-496-0677.

TURNTABLES

Want to Sell

Technics SL1500 MK II, in gd cond, \$275. E Kain, WNOE, 529 Bienville, New Orleans LA 70130. 504-529-1212.

Stanton 310 preamp, many new Stanton 881S, D81S, 600/610 cartridges & stylis, Stanton 50J replacement stylis & Shure V-15III, BO, B Royster, KOM, 1019 Cordova, San Diego CA 92107. 619-223-3413.

Ramko SP8/E (4) stereo TT preamps, \$75/ea; Micro-Trak 303 12" tonearm, vgc, \$75. E Stolz, KWOD, 1425 River Park, Sacramento CA 95815. 916-929-5000.

Micro-Trak 303 (2) tone arms, gd cond, BO; Audio Technica turntable bases (3), BO; Technics SP-15 (2), gd cond, BO; Audio Technica ATP-12T tone arms, gd cond, BO. D Wolfe, KRUX, 901 E Pike Blvd, Westlaco TX 78596. 512-968-1548.

Russco Studio Pro w/Graco wood arm, \$100. W Kremer, 301 SW 16th, Ft Lauderdale FL 33315. 305-524-5652.

Panasonic SL-1700 MK 2, Technics quartz direct drive TT system, vgc, \$150. D Weston, KCOP, 5922 W 76th, Los Angeles CA 90045. 213-216-7814.

RCA 328 12" (4), includes tonearms & preamps, \$265/all plus shpg, D Silver, KNKK, Layton Hills Mall, Layton UT 84041. 801-973-7759.

Scully LS-76 stereo mastering system, lathe Westrex 30III system; Technics SP-10 MK II. Kinura Records, Box 660236, Miami Springs FL 33166. 305-887-5329.

RCA tonearms (2), BO; (4) Micro-Trak tonearms, BO; (2) Gates MG244B mono preamps, gd cond, BO; (2) RCA BA26B mono preamps, gd cond, BO. J Keller, WKOK, POB 1070, Sunbury PA 17801. 717-286-5838.

QRK (2), one in gd cond, one in fair cond, drilled for Micro-Trak 303 tone arms, some spare parts including motor, BO. P Hess, 134 Derwent Dr, Pgh PA 15237. 412-366-1249.

QRK 3 speed 12" w/Rek-O-Kut tonearm, gd cond w/nice brown felt top, \$85/BO. W Dougherty Jr, 314-998-2377 aft 6PM.

Technics SP-15 vgc w/Technics hardwood base, dust cover, EPA titanium tonearm, Stanton 600A cartridge w/new stylus, \$700. Corey Greenberg, KBTS, 4030 W Braker Ste 175, Austin TX 78759. 512-345-9300.

Want to Buy

RCA, Presto record cutters. A Weiner, Britton Rd, Monticello ME 04760. 207-538-9538.

Technics SP10MKII instructions & service info needed, photocopy OK, will pay for postage & copying charges. P Hess, 134 Derwent Dr, Pgh PA 15237. 412-366-1249.

TV FILM EQUIP

Want to Sell

Buhl Multiplexer 573-200-(190) film chain w/4" lens, (2) Kodak 650-H projectors, manuals, top cond, video, film, slide dup & transfer, \$500. B Bridges, KCAM-TV, 827 Meridian, Nashville TN 37207. 615-226-1122.

VIDEO PROD EQUIP

Want to Sell

BTX 4500 time code synchronizer, BO. R Rhodes, POB 1550, NYNY 10101. 212-245-5045.

BTX 4500 non-chase synchronizer, \$595. G Freeman, Pranava Prod, 1227 Sierra Alta Way, Los Angeles CA 90069. 213-457-8390.

IVC/Quantel TBC-2000 direct-only, wideband 4-line TBC (2), one working well & one for parts, manual included, \$1200/BO. G Odell, TFG, Box 9, Wethersfield CT 06109. 203-527-2972.

Complete mobile audio/music video system, JVC, Zenith, Numark, EV, Meteor, (2) projectors, (2) screens, (4) speakers, 1600 music videos, lights, \$10,000. J Whitehead, WQBE, POB 871, Charleston WV 25323. 304-744-9691.

Cohu 2614-400 video waveform multiplexers (2), parade display, w/manuals, \$50 ea; RCA MI-557301 module extender, \$25; Trompeter LPL-75 video patch plugs, 1" spacing, new, \$3 ea; Vital VI-500 color proc amp w/cable equalization, w/manual, \$75. B Humpherys, UMC 8500, Logan UT 84322. 801-750-3133.

Sony RM-580 remote control unit for VTR, never used, \$525. B Bridges, KCAM, 827 Meridian, Nashville TN 37207. 615-226-1122.

Panasonic editing system, 1/2" VHS, under warranty until 11/89, less than 100 hrs, (2) AG-6500 decks, AG-A750 controller, \$6700; Hitachi 13" color under warranty & (2) CT1386B, \$450/both; Fuji T-30 VHS w/bk hard-cover case (450), \$3.30 per unit, price for entire lot \$7000. D Murray, Murray Video Prod, 1918 Sloan, Latrobe PA 15650. 412-539-0465.

Sony FP-62 video projector, 30" to 200" w/built-in tuner, includes shipping case, \$750. R Nimtz, U of Notre Dame, POB 1088, Notre Dame IN 46556. 219-239-6423.

Telemet 350B video test signal gen, w/access, \$250; Computer Image Corp 3-bus program & prod video switcher, EFX, joystick, 2 faders, variable border, chroma-key, \$2000; (2) RCA proc amps/DA card frames, modules, pwr supply, \$50/log; Conrac 7" mono monitor, HP7803A scope, 19" Conrac dual rack frame, \$150/lot; Telechrome video/audio modulator, chnl 4 module incl, vgc, \$1000. E Stolz, KWOD, 1425 River Park, Sacramento CA 95815. 916-929-5000.

Sony CVM-1900 profess monitor/rcvrs, low hrs, excel cond (2), \$700 ea. B Bridges, KCAM-TV, 827 Meridian, Nashville TN 37207. 615-226-1122.

Audio Kinetics Pacer chase synchronizer w/remote pacer pad & interconnect cables to Tascam Series audio recorders, sync-locks multi-track ATR to any make VTR, new cond, \$1500. B Dombrowski, Whirlwind Prod, 10356 W Warren, Dearborn MI 48126. 313-584-4038.

Panasonic AU-B110 AC adaptor, new in box, \$125. B Bridges, KCAM-TV, 827 Meridian, Nashville TN 37207. 615-226-1122.

Tekskil 909 teleprompter, complete & portable, excel cond, \$2800. B Bridges, KCAM, 827 Meridian, Nashville TN 37207. 615-226-1122.

Illusion digital EFX, all upgrades thru 1988, bubble, perspec, rotation, exceptional unit w/striking effects, like new, \$22,000. B Bridges, KCAM, 827 Meridian, Nashville TN 37207. 615-226-1122.

Panasonic AU-A30 edit controller, new, \$650. B Bridges, KCAM-TV, 827 Meridian, Nashville TN 37207. 615-226-1122.

Sony SLO-383 edit recorder, new cond (2), industrial Beta, \$1200 ea. B Bridges, KCAM-TV, 827 Meridian, Nashville TN 37207. 615-226-1122.

Sigma CSG-350A video master sync generator, new, \$925. B Bridges, KCAM-TV, 827 Meridian, Nashville TN 37207. 615-226-1122.

Sony SLO-260 R/P, new components to SLO-383 edit pac (2), \$600 ea. B Bridges, KCAM-TV, 827 Meridian, Nashville TN 37207. 615-226-1122.

JVC 3/4" edit system, CP 5500 player, CR 8200 recorder w/convergence controller ESC 90, includes all cables, breakout box, new head, excel cond, \$4200. Vanessa Gerwels, Peregrine Prod, 317 Weisgerber Bldg, Lewiston ID 83501. 208-743-8618.

JVC CR4400U (4) 3/4" portapacks w/access, \$800/BO; (3) JVC BR6400U VHS source edit deck, \$1400/BO; Kodak 16mm telecine projector; RCA 16mm telecine projector, editing system w/Sony RM 400, VP 2260, VP 2860, \$2000/BO; 3M image enhancer; Panasonic NV 9300 recorder; Sony 2610 recorder. T Quinn, Monte Vista Slds, 208 Cherry, Capitola CA 95010. 408-475-0423.

Trompeter original gold J13-75 patch jacks, PN-2BE-75 (2M, 1F) paralleling, PNS-3/625 & PNS-4/625, TPC-9-75. O Berliner, SoundDesign, Box 921, Beverly Hills CA 90213. 213-276-2726.

Want to Buy

Sony RM-400 edit controller w/cables in fair-gd cond. P Badger, Box 104, Birdsnest VA 23307. 804-442-4037.

VIDEO TAPE RECORDERS

Want to Sell

JVC CR4400U 3/4 port recorders (4) w/access, \$800 ea/BO; (3) Sony RM-430 edit controllers, \$500/BO; JVC BR-6400U VHS recorder, \$1500/BO. T Quinn, Monte Vista Sid, 208 Cherry, Capitola CA 95010. 408-475-0423.

JVC CR6600U 3/4", low hrs, nice shape, \$1650. J Kreines, 5330 Kennedy, Millbrook AL 36054. 205-285-6179.

Sony VO-6800 portable 3/4" U-matic VTR, AC-PS, 8-NP1's w/charger, Kangaroo case/strap incl, \$2950. S Christian, Masterpiece Video Prod, 715 Cornwall, Silver Spring MD 20901. 301-439-5731.

Sony/Ampex 1", vgc, \$24,000; Sony VO-2600 U-matic VTRs, gd cond, \$350; blank 3/4" Betacam tape, \$4 ea. Ugly George, 212-677-2200, M-F, 9AM-5PM, Fax: 212-941-0956, M-F, 9-5.

RCA MI-4069B RCP for RCA TR-50 VTR, \$25. B Humpherys, UMC 8500, Logan UT 84322. 801-750-3133.

Panasonic AU-100 broadcast 1/2" M-format portable VTR, dockable to AK-100 camera, excel cond, \$1200. B Bridges, KCAM-TV, 827 Meridian, Nashville TN 37207. 615-226-1122.

Panasonic AU-300 1/2", M-format bdct VTR/edit, excel cond, \$2500. Brenda Bridges, KCAM-TV, 827 Meridian St, Nashville TN 37207. 615-226-1122.

WORLDWIDE DIGITAL CONVERSION

ALL FORMATS BROADCAST QUALITY Pal Multi-Dupe/Hi-Band/1"

TK VIDEO 12300 Coppola Drive Potomac, MD 20854 301-762-2766

JVC CR6600U 3/4" recorder, low hrs, nice shape, \$1250. J Kreines, DeMott/Kreines Films, 5330 Kennedy, Millbrook AL 36054. 205-285-6179.

Ampex VPR-2B 1" studio editing VTR's (3) w/slo-mo & spec effects, (2) TBC's, excel cond, \$21,000 ea or \$50,000 for all. Ugly George, 212-677-2200, M-F, 9-5; Fax 212-941-0956, M-F, 9-5.

Misc 3/4" decks for sale/trade for other A/V equip. Write/call w/want list & list of what you have to trade; Also need stereo cart machines, Ampex 350 R/P solid state electr & more. N Mishaan, POB 335, Lynbrook NY 11583. 516-582-1338.

JVC, Sony, Panasonic, (8) players, all need some repair or use as parts, \$50 ea. K Taylor, Image Support, 103 N Aspen, Sterling VA 22170. 301-864-4841.

Want to Buy

Ampex VR-3000 portable quad VTR. A Weiner, Britton Rd, Monticello ME 04760. 207-538-9538.

RCA TR-3, TR-5 quad machines. A Weiner, Britton Rd, Monticello ME 04760. 207-538-9538.

Panasonic 6200 Series 6210 or equivalent model VHS hi-fi recorder in excel or vg working cond. L Fields, 3259 N Sheffield, Chicago IL 60657. 312-935-3635.

ACTION-GRAM

Equipment Listings

Radio World's Broadcast Equipment Exchange provides a FREE listing service for all broadcast and pro-sound end users. Simply send your listings to us, following the example below. Please indicate in which category you would like your listing to appear. Mail your listings to the address below. Thank you.

Please print and include all information:

Contact Name: _____ Title _____ Company/Station _____ Address: _____ City _____ State _____ Zip _____

Phone Number: _____

Brokers, dealers, manufacturers and other organizations who are not legitimate end users can participate in the Broadcast Equipment Exchange on a paid basis. Listings are available on a \$25/25 word basis. Call 1-800-336-3045 for details and complete display rates.

I would like to receive or continue receiving Radio World FREE each month. YES NO

Signature _____ Date _____ Please circle only one entry for each category:

I. Type of Firm

- D. Combination AM/FM station F. Recording studio
A. Commercial AM station G. TV station/teleprod facility
B. Commercial FM station H. Consultant/ind engineer
C. Educational FM station I. Mfg, distributor or dealer
E. Network/group owner J. Other

II. Job Function

- A. Ownership D. Programming/production
B. General management E. News operations
C. Engineering F. Other

WTS: WTB: Category: _____

Make: _____ Model #: _____

Brief Description: _____

Price: _____

WTS: WTB: Category: _____

Make: _____ Model #: _____

Brief Description: _____

Price: _____

WTS: WTB: Category: _____

Make: _____ Model #: _____

Brief Description: _____

Price: _____

WTS: WTB: Category: _____

Make: _____ Model #: _____

Brief Description: _____

Price: _____

MARKETPLACE

Send us your new product info. Be sure to include a black and white photo. Send all submissions to Radio World Marketplace, P.O. Box 1214, Falls Church, VA 22041

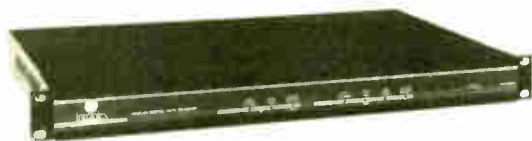

Rate reducer

The DRR-1500 digital rate reducer is one of Intraplex's Intralink series of T1 multiplex and DACs communications equipment.

The unit links only those channels within the T1 signal needed by the user for transmission over terrestrial and satellite networks.

The DRR-1500 interconnects T1 equipment such as multiplexers, PBXs and switchers at rate less than the T1 aggregate.

It also provides end-to-end T1 frame transparency.

DRR-1500 is available in both simplex and duplex configurations.

For information, call Roger Shaw at Intraplex Inc.: 508-486-3722, or circle Reader Service 83.



Telephone hybrid

Gentner's new Digital Hybrid II is a digitally processed telephone hybrid for broadcast and audio conferencing.

The unit uses a 16-bit Motorola digital processor for isolation of telephone send and receive signals.

The Digital Hybrid interfaces with a variety of telephone systems, mic mixers and PA equipment.

For broadcast operations, the unit provides push-button switching between mix-minus and mic preamp outputs.

For information, call Kelli Maag at Gentner Electronics: 801-975-7200, or circle Reader Service 64.



Interconnect cable

Belden Wire and Cable's 1266A is a NEC CM rated miniature twisted pair audio interconnect cable.

Features include: a 22 AWG (7 x 30) twisted pair tinned copper conductor, polypropylene insulation and electrostatic reinforced metallic foil shielding.

For information, call Belden Wire and Cable's marketing department at: 1-800-BELDEN-4, or circle Reader Service 51.



Tape degausser

The TD-5 metal partial tape degausser by Audiolab will erase and neutralize both high coercivity tape cartridges (i.e. Beta SP, M-II, DAT, D1-2 and 8 mm) reels up to 16 inches in diameter and two inches in width.

For information, call Ronald Stofan at Audiolab Electronics: 916-348-0200, or circle Reader Service 92.

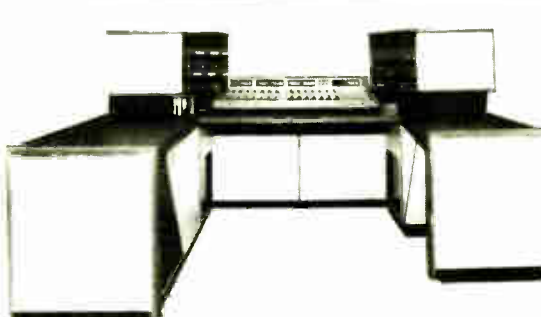

Studio furniture

Features of Murphy's Elite Series of studio furniture include non-chip rounded bumper base laminated to a solid hardwood molding, three built-in parallel wire passes, access panels along the entire back and ventilating reveal at top.

The underconsole racks are field relocatable.

The furniture is available in both stand-up and sit-down configurations with a two-to-eight week delivery time.

For information, call Dennis Murphy at Murphy Studio Furniture: 619-698-4658, or circle Reader Service 74.



Condenser mic

The MKH 50-P48, by Sennheiser, is a symmetrical transducer, transformerless mic for digital recording which comes complete with an MQZ 40 stand adapter.

It includes a switchable 10 dB pad and proximity effect compensation filter.

The MKH 50-P48 uses a symmetrical push-pull capsule design incorporating optimum resistive loading for an ultra linear response.

For information, call Tony Tudisco at Sennheiser Electronics: 203-434-9190, or circle Reader Service 55.

Subscription/Reader Service Form

Radio World

November 8, 1989 Issue Use until February 7, 1990
FREE Subscription/Renewal Form

I would like to receive or continue receiving Radio World FREE each month. YES NO

Signature _____ Date _____

Please print and include all information:

Name _____ Title _____

Company/Station _____

Address _____

City _____ State _____ ZIP _____

Business Telephone () _____

Please circle only one entry for each category:

- I. Type of Firm
 D. Combination AM/FM station F. Recording studio
 A. Commercial AM station G. TV station/teleprod facility
 B. Commercial FM station H. Consultant/ind engineer
 C. Educational FM station I. Mfg, distributor or dealer
 E. Network/group owner J. Other

- II. Job Function
 A. Ownership D. Programming/production
 B. General management E. News operations
 C. Engineering F. Other (specify)

- III. Purchasing Authority
 1. Recommend 2. Specify 3. Approve

Reader Service

Please first fill out contact information at left. Then check each advertisement for corresponding number and circle below. NOTE: Circle no more than 15 numbers, otherwise card will not be processed.

001	021	041	061	081
002	022	042	062	082
003	023	043	063	083
004	024	044	064	084
005	025	045	065	085
006	026	046	066	086
007	027	047	067	087
008	028	048	068	088
009	029	049	069	089
010	030	050	070	090
011	031	051	071	091
012	032	052	072	092
013	033	053	073	093
014	034	054	074	094
015	035	055	075	095
016	036	056	076	096
017	037	057	077	097
018	038	058	078	098
019	039	059	079	099
020	040	060	080	100

ADVERTISER INDEX

This listing is provided solely for the convenience of our readers. Radio World assumes no liability for inaccuracy.

Page No.	Advertiser	Reader Service No.	Page No.	Advertiser	Reader Service No.	Page No.	Advertiser	Reader Service No.
9	3M	99	10	BSW	14	33	Hnat Hinds	17
37	AKG Acoustics	26	23	BSW	79	43	IBSS	13
18	Allied Broadcast	56	27	BSW	42	41	LPB	46
20	Allied Broadcast	52	35	BSW	12	12	Moseley Assoc.	50
40	Allied Broadcast	81	4	Burk Technology	48	24	Northeast Broadcast	60
42	Allied Broadcast	10	36	CCA	67	44	Northeast Broadcast	49
43	Allied Broadcast	87	10	Communications Data Services	27	21	Orban	29
49	Allied Broadcast	22	32	Comrex	41	13	Otari	95
6	Allied Broadcast	11	22	Continental Electronics	33	11	Pacific Recorders & Engineering	93
30/31	Arrakis Systems	8	44	Cortana	84	59	Panasonic/Technics	23
49	ATI	89	41	CRL	24	46	QEI	5
7	ATI	61	34	Current Technology	15	14	Radio Systems	54
29	Audio Broadcast Group	43	38	Cutting Edge	1	47	Radio Systems	28
33	Audiopak	62	8	Cutting Edge	2	7	Radio World Annual	
45	Auditronics	68	44	Dataworld	3	36	RF Specialties	4
24	Belar	82	39	Delta Electronics	35	25	Shure	63
15	Bradley Broadcasting	18	28	Di-Tech	36	22	Sony	
3	Bradley Broadcasting	6	26	Eventide	65	48	Studer Revox	80
16	Broadcast Electronics	91	1	Fidelipac	21	8	Tannoy	31
3	Broadcast Electronics	85	19	Gentner	88	40	Tri-Tech	32
38	Broadcast Services	90	18	Harris	72	23	Western International	97
28	Broadcasters General Store	70	33	Hnat Hinds	75	2	Wheatstone	44
						60	Wheatstone	9

Advertising Sales Representatives:

East & Midwest, Art Constantine: 800-336-3045 Fax: 703-998-2966
 West Coast, Pat Macsata: 415-786-2198 Fax: 415-786-2754



THE PROFESSIONAL CD PLAYER FOR THE PROFESSIONAL CD PLAYER.

Like all professional CD players, the new Technics SL-P1300 is technologically advanced.

But you don't have to be a technical genius to operate it.

In fact, even if you haven't spent years in the studio, it will only take you a few minutes to figure it out.

You see, the SL-P1300 is ergonomically designed to give you greater

control over playback than you've ever had before.

Perhaps that's because it's built like a recording console. Which means the disc well and all the other controls are right at your fingertips.



First, the control panel features a long stroke sliding pitch control. It's continuously variable with a range of $\pm 8\%$. In addition, it lets you restore quartz lock accuracy at the touch of a button.

There's also our two-speed search dial with audible pause. Which makes finding your in point extremely easy.

Our professional CD player has other features professionals enjoy working with. Like one-touch memorization by time code, A-B repeat, and our exclusive rocker control search buttons. It's the digital equivalent of dragging your

finger on the edge of a record.

A great deal of thinking also went into things like our balanced outputs (10 dBm nominal into 600 ohms). There's even a port for a wired remote. And separate power supplies for digital and analog circuits. Given this, it's not surprising that its S/N ratio is 112 dB.

If you're a professional CD player, chances are you're ready to hear what our professional CD player can do.

Call your Technics representative. You'll find that our pro CD player isn't the only thing from Technics that's a pleasure to work with.

Technics
The science of sound



A SUCCESS STORY

THE OBJECTIVE was no small task: design a radio console that would become the new standard.

THE METHOD involved listening to veteran broadcast engineers and installers. After all, they're the people who have seen and experienced all the ideas that came before. From this research we learned of the problems that had to be solved and the features that broadcasters required. We then added ten years of console building experience and innovation, and created the A-500a console.

THE RESULT: An unsurpassed console that exceeds prior broadcast standards. Its module/mainframe interface borrows from the computer industry, utilizing all-gold contact insulation displacement technology. The logic system is based on programming the module slot, allowing full module interchangeability. It also provides for separate programming of the module's "B" input selection, thus avoiding embarrassing false starts and mutes. Full console-to-machine control is supported without extensive use of interface boxes and cables. Three audio busses are provided to enhance talkshows and remote functions. There are separate processing loops for the speech and music paths, as well as individual channel insert points. A complete line of microphone and line inputs, remote selectors, and machine control modules is offered in virtually any combination, configuration or mainframe size you desire. The A-500a also features a full family of studio turret and turret components to ease facility design.

THE PERFORMANCE: Needless to say, it's a new age for audio, and the A-500a is a step ahead. While specifications don't say it all, ruler flat frequency response, .003% distortion, crisp square wave response and a noise spec that's unheard of deserve merit. Couple such performance, reliability and innovation together, and a new broadcast standard is set.

THE SUCCESS: WHEATSTONE broadcast consoles are installed in major markets all over the country, from frontline independents to national networks. They are in use right now at some of the world's largest institutions.

THE POSSIBILITIES: The possibilities are up to you.

 Wheatstone Corporation

6720 V.I.P. Parkway, Syracuse, N.Y. 13211 315-455-7740

Circle World Radio History Card